

CD40106B CMOS Hex Schmitt-Trigger Inverters

1 Features

- Schmitt-Trigger Inputs
- Hysteresis Voltage (Typical):
 - 0.9 V at $V_{DD} = 5$ V
 - 2.3 V at $V_{DD} = 10$ V
 - 3.5 V at $V_{DD} = 15$ V
- Noise Immunity Greater Than 50%
- No Limit On Input Rise and Fall Times
- Standardized, Symmetrical Output Characteristics
- For Quiescent Current at 20 V
- Maximum Input Current Of 1 μ A at 18 V Over Full Package Temperature Range:
 - 100 nA at 18 V and 25°C
- Low V_{DD} and V_{SS} Current During Slow Input Ramp
- 5-V, 10-V, and 15-V Parametric Ratings

2 Applications

- Wave and Pulse Shapers
- High-Noise-Environment Systems
- Monostable Multivibrators
- Astable Multivibrators

3 Description

The CD40106B device consists of six Schmitt-Trigger inputs. Each circuit functions as an inverter with Schmitt-Trigger input. The trigger switches at different points for positive- and negative-going signals. The difference between the positive-going voltage (V_P) and the negative-going voltages (V_N) is defined as hysteresis voltage (V_H).

The CD40106B device is supplied in ceramic packaging (J) as well as standard packaging (D, N, NS, PW). All CD40106B devices are rated for -55°C to $+125^\circ\text{C}$ ambient temperature operation.

Device Information⁽¹⁾

PART NUMBER	PACKAGE	BODY SIZE (NOM)
CD40106BF	CDIP (14)	6.92 mm x 19.94 mm
CD40106BE	PDIP (14)	6.30 mm x 19.31 mm
CD40106BM	SOIC (14)	3.90 mm x 8.65 mm
CD40106BNSR	SO (14)	5.30 mm x 10.20 mm
CD40106BPWR	TSSOP (14)	4.40 mm x 5.00 mm

(1) For all available packages, see the orderable addendum at the end of the data sheet.

Logic Diagram

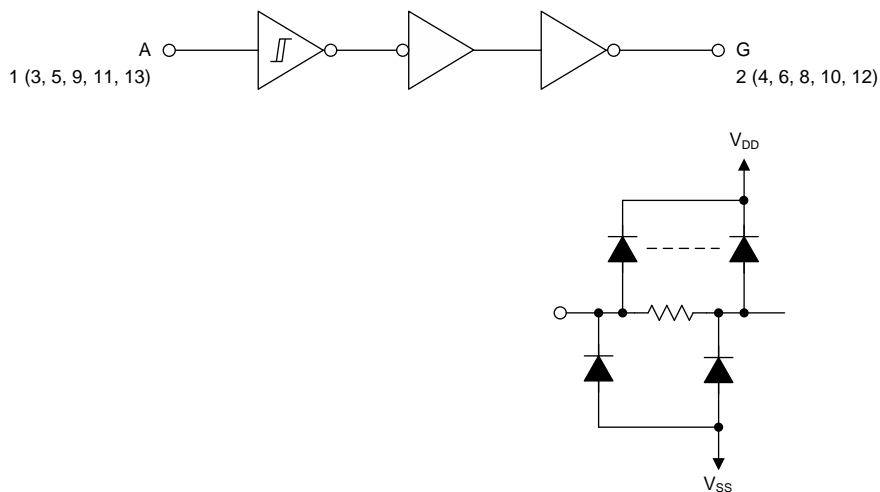

Copyright © 2017, Texas Instruments Incorporated

All inputs protected by the protection network shown to the right



Table of Contents

1 Features 1 2 Applications 1 3 Description 1 4 Revision History 2 5 Pin Configuration and Functions 3 6 Specifications 4 6.1 Absolute Maximum Ratings 4 6.2 ESD Ratings 4 6.3 Recommended Operating Conditions 4 6.4 Thermal Information 4 6.5 Electrical Characteristics: Static 5 6.6 Electrical Characteristics: Dynamic 8 6.7 Typical Characteristics 9 7 Parameter Measurement Information 11 8 Detailed Description 13 8.1 Overview 13 8.2 Functional Block Diagram 13	8.3 Feature Description 13 8.4 Device Functional Modes..... 13 9 Application and Implementation 14 9.1 Application Information 14 9.2 Typical Applications 14 10 Power Supply Recommendations 16 11 Layout 16 11.1 Layout Guidelines 16 11.2 Layout Example 16 12 Device and Documentation Support 18 12.1 Receiving Notification of Documentation Updates 18 12.2 Community Resources 18 12.3 Trademarks 18 12.4 Electrostatic Discharge Caution 18 12.5 Glossary 18 13 Mechanical, Packaging, and Orderable Information 18
---	--

4 Revision History

NOTE: Page numbers for previous revisions may differ from page numbers in the current version.

Changes from Revision E (September 2016) to Revision F	Page
--	------

- | | |
|---|---|
| • Changed incorrect pin descriptions to match package drawing | 3 |
|---|---|

Changes from Revision D (August 2003) to Revision E	Page
---	------

- | | |
|--|---|
| • Added <i>ESD Ratings</i> table, <i>Feature Description</i> section, <i>Device Functional Modes</i> , <i>Application and Implementation</i> section, <i>Power Supply Recommendations</i> section, <i>Layout</i> section, <i>Device and Documentation Support</i> section, and <i>Mechanical, Packaging, and Orderable Information</i> section | 1 |
| • Added <i>Thermal Information</i> table | 4 |

5 Pin Configuration and Functions

D, J, N, NS, PW Packages
14-Pin SOIC, CDIP, PDIP, SO, TSSOP
Top View

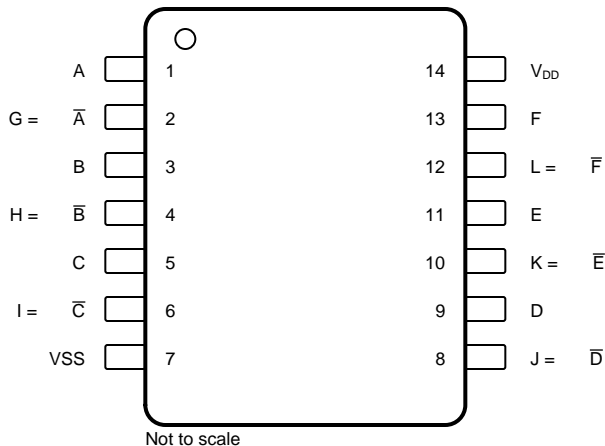

Pin Functions

PIN		I/O	DESCRIPTION
NO.	NAME		
1	A	I	Channel A input
2	$G = \bar{A}$	O	Channel A inverted output
3	B	I	Channel B input
4	$H = \bar{B}$	O	Channel B inverted output
5	C	I	Channel C input
6	$I = \bar{C}$	O	Channel C inverted output
7	V_{SS}	—	Ground
8	$J = \bar{D}$	O	Channel D inverted output
9	D	I	Channel D input
10	$K = \bar{E}$	O	Channel E inverted output
11	E	I	Channel E input
12	$L = \bar{F}$	O	Channel F inverted output
13	F	I	Channel F input
14	V_{DD}	—	Power supply

6 Specifications

6.1 Absolute Maximum Ratings

over operating free-air temperature range (unless otherwise noted)⁽¹⁾

		MIN	MAX	UNIT
DC supply voltage, V_{DD} ⁽²⁾		-0.5	20	V
Input voltage, all inputs		-0.5	$V_{DD} + 0.5$	V
DC input current, any one input			±10	mA
Power dissipation, P_D	$T_A = -55^{\circ}\text{C}$ to $+100^{\circ}\text{C}$		500	mW
	$T_A = 100^{\circ}\text{C}$ to 125°C ⁽³⁾		200	
Device dissipation per output transistor			100	mW
Maximum junction temperature, T_J			150	$^{\circ}\text{C}$
Storage temperature, T_{stg}		-65	150	$^{\circ}\text{C}$

- (1) Stresses beyond those listed under *Absolute Maximum Ratings* may cause permanent damage to the device. These are stress ratings only, which do not imply functional operation of the device at these or any other conditions beyond those indicated under *Recommended Operating Conditions*. Exposure to absolute-maximum-rated conditions for extended periods may affect device reliability.
- (2) Voltages referenced to V_{SS} terminal
- (3) Derate linearity at 12 mW/ $^{\circ}\text{C}$

6.2 ESD Ratings

			VALUE	UNIT
$V_{(ESD)}$	Electrostatic discharge	Human-body model (HBM), per ANSI/ESDA/JEDEC JS-001 ⁽¹⁾	2000	V
		Charged-device model (CDM), per JEDEC specification JESD22-C101 ⁽²⁾	1000	

- (1) JEDEC document JEP155 states that 500-V HBM allows safe manufacturing with a standard ESD control process.
- (2) JEDEC document JEP157 states that 250-V CDM allows safe manufacturing with a standard ESD control process.

6.3 Recommended Operating Conditions

over operating free-air temperature range (unless otherwise noted)

		MIN	MAX	UNIT
Supply voltage		3	18	V
Operating temperature, T_A		-55	125	$^{\circ}\text{C}$

6.4 Thermal Information

THERMAL METRIC ⁽¹⁾	CD40106B				UNIT	
	D (SOIC)	N (PDIP)	NS (SO)	PW (TSSOP)		
	14 PINS	14 PINS	14 PINS	14 PINS		
$R_{\theta JA}$	Junction-to-ambient thermal resistance	86.1	51.3	83.5	114.1	$^{\circ}\text{C}/\text{W}$
$R_{\theta JC(top)}$	Junction-to-case (top) thermal resistance	44.3	38.6	41.5	39.1	$^{\circ}\text{C}/\text{W}$
$R_{\theta JB}$	Junction-to-board thermal resistance	40.6	31.2	42.2	56.9	$^{\circ}\text{C}/\text{W}$
Ψ_{JT}	Junction-to-top characterization parameter	11.6	23.4	13.1	3.1	$^{\circ}\text{C}/\text{W}$
Ψ_{JB}	Junction-to-board characterization parameter	40.3	31.3	41.8	56.2	$^{\circ}\text{C}/\text{W}$

- (1) For more information about traditional and new thermal metrics, see the [Semiconductor and IC Package Thermal Metrics](#) application report.

6.5 Electrical Characteristics: Static

over operating free-air temperature range (unless otherwise noted)

PARAMETER		TEST CONDITIONS		MIN	TYP	MAX	UNIT
I_{DDmax}	Quiescent device current	$V_{IN} = 0$ or 5, $V_{DD} = 5$	$T_A = -55^\circ\text{C}$			1	μA
			$T_A = -40^\circ\text{C}$			1	
			$T_A = 25^\circ\text{C}$		0.02	1	
			$T_A = 85^\circ\text{C}$			30	
			$T_A = 125^\circ\text{C}$			30	
		$V_{IN} = 0$ or 10, $V_{DD} = 10$	$T_A = -55^\circ\text{C}$			2	
			$T_A = -40^\circ\text{C}$			2	
			$T_A = 25^\circ\text{C}$		0.02	2	
			$T_A = 85^\circ\text{C}$			60	
			$T_A = 125^\circ\text{C}$			60	
		$V_{IN} = 0$ or 15, $V_{DD} = 15$	$T_A = -55^\circ\text{C}$			4	
			$T_A = -40^\circ\text{C}$			4	
			$T_A = 25^\circ\text{C}$		0.02	4	
			$T_A = 85^\circ\text{C}$			120	
			$T_A = 125^\circ\text{C}$			120	
		$V_{IN} = 0$ or 20, $V_{DD} = 20$	$T_A = -55^\circ\text{C}$			20	
$T_A = -40^\circ\text{C}$				20			
$T_A = 25^\circ\text{C}$			0.04	20			
$T_A = 85^\circ\text{C}$				600			
$T_A = 125^\circ\text{C}$				600			
V_{Pmin}	Positive trigger threshold voltage	$V_{DD} = 5$	$T_A = -55^\circ\text{C}$	2.2			V
			$T_A = -40^\circ\text{C}$	2.2			
			$T_A = 25^\circ\text{C}$	2.2	2.9		
			$T_A = 85^\circ\text{C}$	2.2			
			$T_A = 125^\circ\text{C}$	2.2			
		$V_{DD} = 10$	$T_A = -55^\circ\text{C}$	4.6			
			$T_A = -40^\circ\text{C}$	4.6			
			$T_A = 25^\circ\text{C}$	4.6	5.9		
			$T_A = 85^\circ\text{C}$	4.6			
			$T_A = 125^\circ\text{C}$	4.6			
		$V_{DD} = 15$	$T_A = -55^\circ\text{C}$	6.8			
			$T_A = -40^\circ\text{C}$	6.8			
			$T_A = 25^\circ\text{C}$	6.8	8.8		
			$T_A = 85^\circ\text{C}$	6.8			
			$T_A = 125^\circ\text{C}$	6.8			

Electrical Characteristics: Static (continued)

over operating free-air temperature range (unless otherwise noted)

PARAMETER		TEST CONDITIONS		MIN	TYP	MAX	UNIT	
V _{Pmax}	Positive trigger threshold voltage	V _{DD} = 5	T _A = -55°C			3.6	V	
			T _A = -40°C			3.6		
			T _A = 25°C		2.9	3.6		
			T _A = 85°C			3.6		
			T _A = 125°C			3.6		
		V _{DD} = 10	T _A = -55°C					7.1
			T _A = -40°C					7.1
			T _A = 25°C		5.9			7.1
			T _A = 85°C					7.1
			T _A = 125°C					7.1
		V _{DD} = 15	T _A = -55°C					10.8
			T _A = -40°C					10.8
			T _A = 25°C		8.8			10.8
			T _A = 85°C					10.8
			T _A = 125°C					10.8
V _{Nmin}	Negative trigger threshold voltage	V _{DD} = 5	T _A = -55°C	0.9			V	
			T _A = -40°C	0.9				
			T _A = 25°C	0.9	1.9			
			T _A = 85°C	0.9				
			T _A = 125°C	0.9				
		V _{DD} = 10	T _A = -55°C	2.5				
			T _A = -40°C	2.5				
			T _A = 25°C	2.5	3.9			
			T _A = 85°C	2.5				
			T _A = 125°C	2.5				
		V _{DD} = 15	T _A = -55°C	4				
			T _A = -40°C	4				
			T _A = 25°C	4	5.8			
			T _A = 85°C	4				
			T _A = 125°C	4				
V _{Nmax}	Negative trigger threshold voltage	V _{DD} = 5	T _A = -55°C			2.8	V	
			T _A = -40°C			2.8		
			T _A = 25°C		1.9	2.8		
			T _A = 85°C			2.8		
			T _A = 125°C			2.8		
		V _{DD} = 10	T _A = -55°C					5.2
			T _A = -40°C					5.2
			T _A = 25°C		3.9			5.2
			T _A = 85°C					5.2
			T _A = 125°C					5.2
		V _{DD} = 15	T _A = -55°C					7.4
			T _A = -40°C					7.4
			T _A = 25°C		5.8			7.4
			T _A = 85°C					7.4
			T _A = 125°C					7.4

Electrical Characteristics: Static (continued)

over operating free-air temperature range (unless otherwise noted)

PARAMETER		TEST CONDITIONS	MIN	TYP	MAX	UNIT	
V_{Hmin}	Hysteresis voltage	$V_{DD} = 5$	$T_A = -55^\circ\text{C}$	0.3			V
			$T_A = -40^\circ\text{C}$	0.3			
			$T_A = 25^\circ\text{C}$	0.3	0.9		
			$T_A = 85^\circ\text{C}$	0.3			
			$T_A = 125^\circ\text{C}$	0.3			
		$V_{DD} = 10$	$T_A = -55^\circ\text{C}$	1.2			
			$T_A = -40^\circ\text{C}$	1.2			
			$T_A = 25^\circ\text{C}$	1.2	2.3		
			$T_A = 85^\circ\text{C}$	1.2			
			$T_A = 125^\circ\text{C}$	1.2			
		$V_{DD} = 15$	$T_A = -55^\circ\text{C}$	1.6			
			$T_A = -40^\circ\text{C}$	1.6			
			$T_A = 25^\circ\text{C}$	1.6	3.5		
			$T_A = 85^\circ\text{C}$	1.6			
			$T_A = 125^\circ\text{C}$	1.6			
V_{Hmax}	Hysteresis voltage	$V_{DD} = 5$	$T_A = -55^\circ\text{C}$			1.6	V
			$T_A = -40^\circ\text{C}$			1.6	
			$T_A = 25^\circ\text{C}$		0.9	1.6	
			$T_A = 85^\circ\text{C}$			1.6	
			$T_A = 125^\circ\text{C}$			1.6	
		$V_{DD} = 10$	$T_A = -55^\circ\text{C}$			3.4	
			$T_A = -40^\circ\text{C}$			3.4	
			$T_A = 25^\circ\text{C}$		2.3	3.4	
			$T_A = 85^\circ\text{C}$			3.4	
			$T_A = 125^\circ\text{C}$			3.4	
		$V_{DD} = 15$	$T_A = -55^\circ\text{C}$			5	
			$T_A = -40^\circ\text{C}$			5	
			$T_A = 25^\circ\text{C}$		3.5	5	
			$T_A = 85^\circ\text{C}$			5	
			$T_A = 125^\circ\text{C}$			5	
I_{OLmin}	Output low (sink) current	$V_O = 0.4, V_{IN} = 0 \text{ or } 5,$ $V_{DD} = 5$	$T_A = -55^\circ\text{C}$	0.64			mA
			$T_A = -40^\circ\text{C}$	0.61			
			$T_A = 25^\circ\text{C}$	0.51	1		
			$T_A = 85^\circ\text{C}$	0.42			
			$T_A = 125^\circ\text{C}$	0.36			
		$V_O = 0.5, V_{IN} = 0 \text{ or } 10,$ $V_{DD} = 10$	$T_A = -55^\circ\text{C}$	1.6			
			$T_A = -40^\circ\text{C}$	1.5			
			$T_A = 25^\circ\text{C}$	1.3	2.6		
			$T_A = 85^\circ\text{C}$	1.1			
			$T_A = 125^\circ\text{C}$	0.9			
		$V_O = 1.5, V_{IN} = 0 \text{ or } 15,$ $V_{DD} = 15$	$T_A = -55^\circ\text{C}$	4.2			
			$T_A = -40^\circ\text{C}$	4			
			$T_A = 25^\circ\text{C}$	3.4	6.8		
			$T_A = 85^\circ\text{C}$	2.8			
				$T_A = 125^\circ\text{C}$	2.4		

Electrical Characteristics: Static (continued)

over operating free-air temperature range (unless otherwise noted)

PARAMETER		TEST CONDITIONS	MIN	TYP	MAX	UNIT	
I_{OHmin}	Output high (source) current	$V_O = 4.6, V_{IN} = 0$ or 5, $V_{DD} = 5$	$T_A = -55^\circ\text{C}$	-0.64			mA
			$T_A = -40^\circ\text{C}$	-0.61			
			$T_A = 25^\circ\text{C}$	-0.51	-1		
			$T_A = 85^\circ\text{C}$	-0.42			
			$T_A = 125^\circ\text{C}$	-0.36			
		$V_O = 2.5, V_{IN} = 0$ or 5, $V_{DD} = 5$	$T_A = -55^\circ\text{C}$	-2			
			$T_A = -40^\circ\text{C}$	-1.8			
			$T_A = 25^\circ\text{C}$	-1.6	-3.2		
			$T_A = 85^\circ\text{C}$	-1.3			
			$T_A = 125^\circ\text{C}$	-1.15			
		$V_O = 9.5, V_{IN} = 0$ or 10, $V_{DD} = 10$	$T_A = -55^\circ\text{C}$	-1.6			
			$T_A = -40^\circ\text{C}$	-1.5			
			$T_A = 25^\circ\text{C}$	-1.3	-2.6		
			$T_A = 85^\circ\text{C}$	-1.1			
			$T_A = 125^\circ\text{C}$	-0.9			
		$V_O = 13.5, V_{IN} = 0$ or 15, $V_{DD} = 15$	$T_A = -55^\circ\text{C}$	-4.2			
$T_A = -40^\circ\text{C}$	-4						
$T_A = 25^\circ\text{C}$	-3.4		-6.8				
$T_A = 85^\circ\text{C}$	-2.8						
$T_A = 125^\circ\text{C}$	-2.4						
V_{OLmax}	Low-level output voltage	$V_{IN} = 5, V_{DD} = 5$	$T_A = -55^\circ\text{C}, -40^\circ\text{C}, 25^\circ\text{C}, 85^\circ\text{C},$ and 125°C	0	0.05	V	
		$V_{IN} = 10, V_{DD} = 10$	$T_A = -55^\circ\text{C}, -40^\circ\text{C}, 25^\circ\text{C}, 85^\circ\text{C},$ and 125°C	0	0.05		
		$V_{IN} = 15, V_{DD} = 15$	$T_A = -55^\circ\text{C}, -40^\circ\text{C}, 25^\circ\text{C}, 85^\circ\text{C},$ and 125°C	0	0.05		
V_{OHmin}	High-level output voltage	$V_{IN} = 0, V_{DD} = 5$	$T_A = -55^\circ\text{C}, -40^\circ\text{C}, 25^\circ\text{C}, 85^\circ\text{C},$ and 125°C	4.95	5	V	
		$V_{IN} = 0, V_{DD} = 10$	$T_A = -55^\circ\text{C}, -40^\circ\text{C}, 25^\circ\text{C}, 85^\circ\text{C},$ and 125°C	9.95	10		
		$V_{IN} = 0, V_{DD} = 15$	$T_A = -55^\circ\text{C}, -40^\circ\text{C}, 25^\circ\text{C}, 85^\circ\text{C},$ and 125°C	14.95	15		
I_{INmax}	Input current	$V_{IN} = 0$ or 18, $V_{DD} = 18$	$T_A = -55^\circ\text{C}$		± 0.1	μA	
			$T_A = -40^\circ\text{C}$		± 0.1		
			$T_A = 25^\circ\text{C}$	± 0.00001	± 0.1		
			$T_A = 85^\circ\text{C}$		± 1		
			$T_A = 125^\circ\text{C}$		± 1		

6.6 Electrical Characteristics: Dynamic

 at $T_A = 25^\circ\text{C}$, input $t_r, t_f = 20$ ns, $C_L = 50$ pF, and $R_L = 200$ k Ω (unless otherwise noted)

PARAMETER		TEST CONDITIONS	MIN	TYP	MAX	UNIT
t_{PHL}, t_{PLH}	Propagation delay time	$V_{DD} = 5$		140	280	ns
		$V_{DD} = 10$		70	140	
		$V_{DD} = 15$		60	120	
t_{THL}, t_{TLH}	Transition time	$V_{DD} = 5$		100	200	ns
		$V_{DD} = 10$		50	100	
		$V_{DD} = 15$		40	80	
C_{IN}	Input capacitance	Any input		5	7.5	pF

6.7 Typical Characteristics

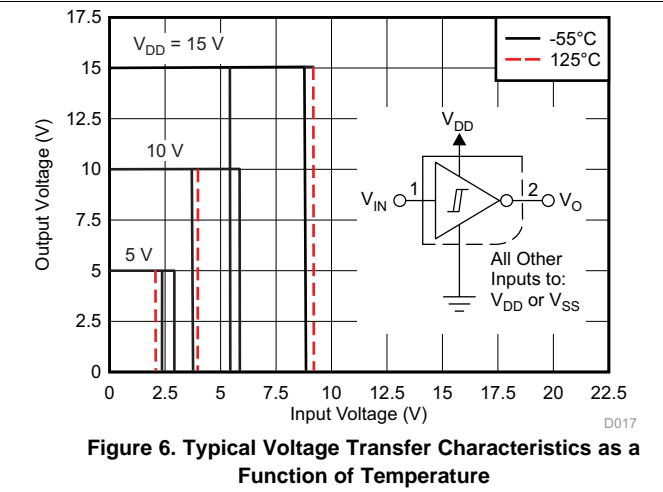
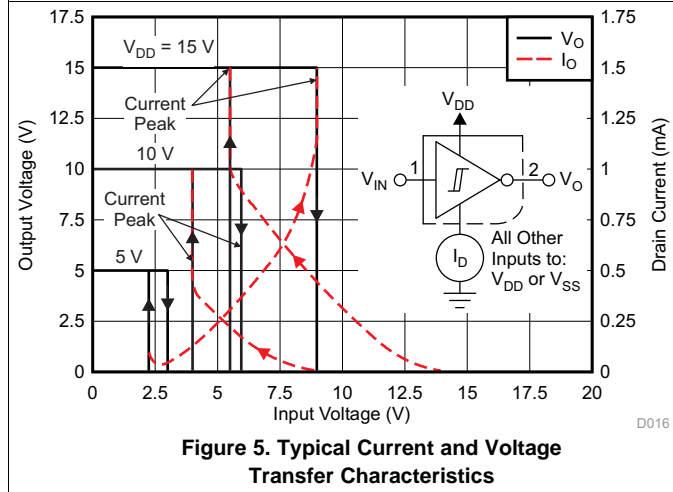
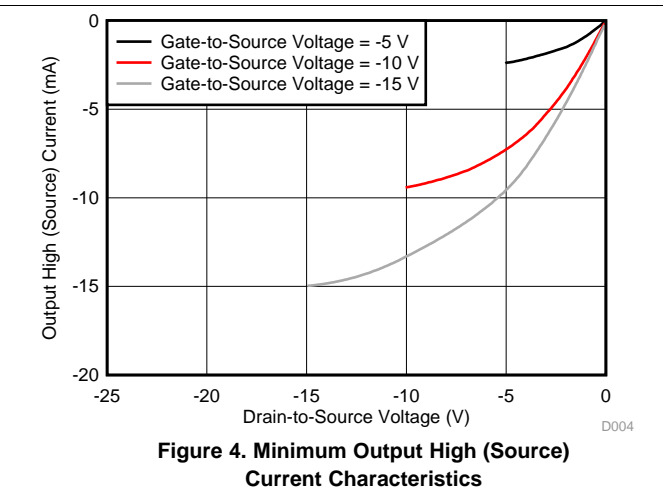
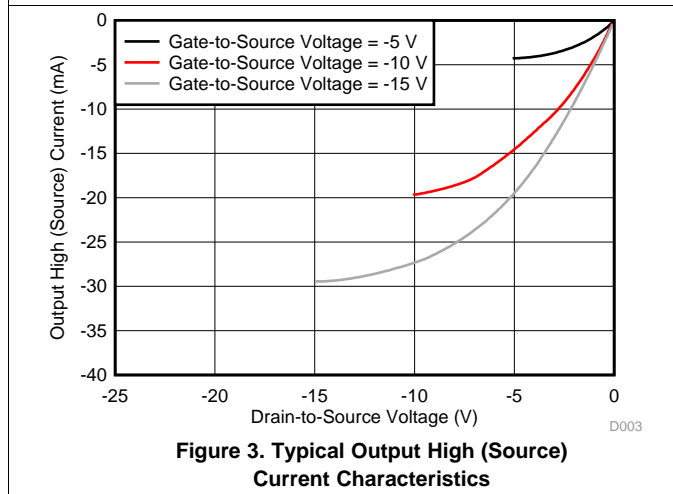
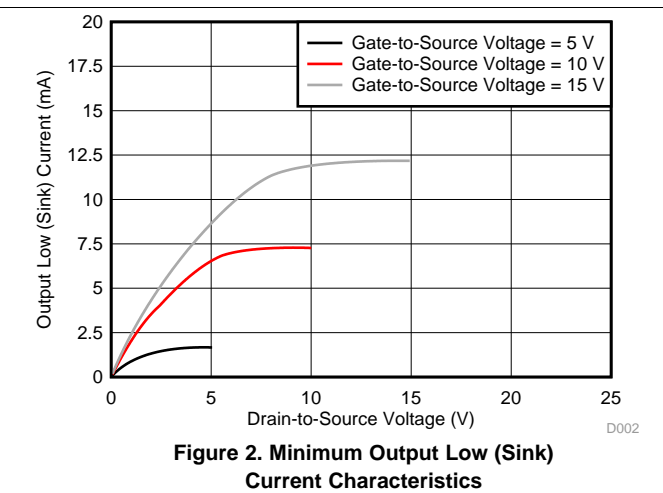
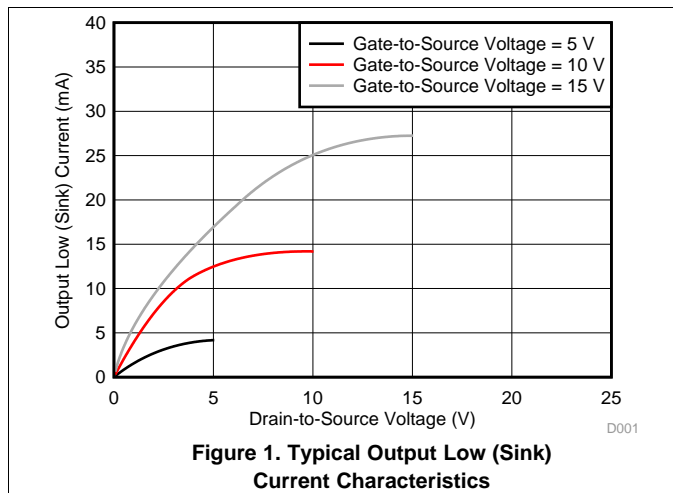

Typical Characteristics (continued)

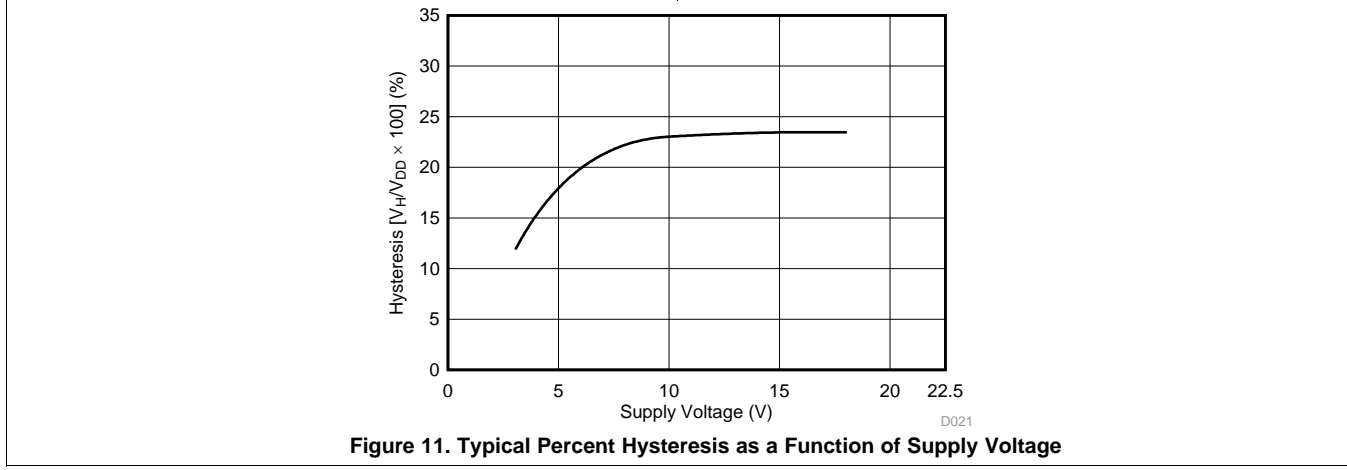
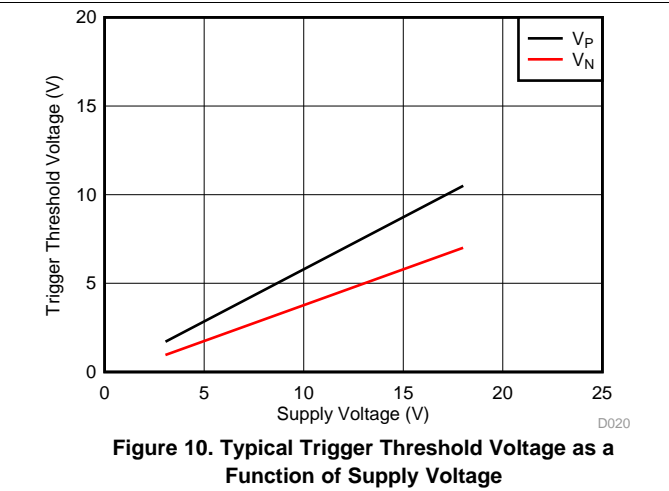
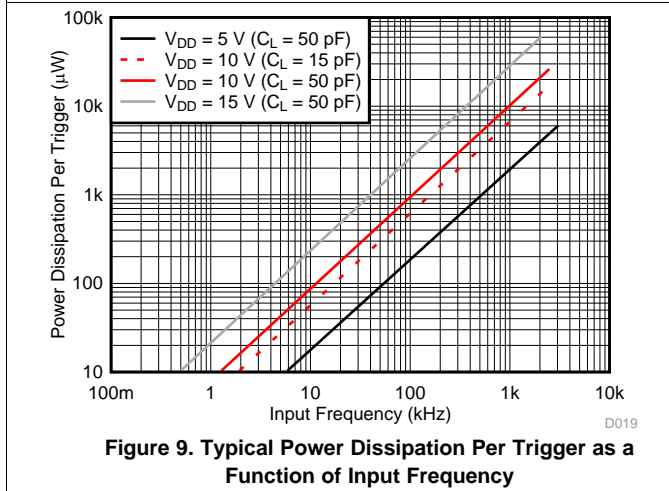
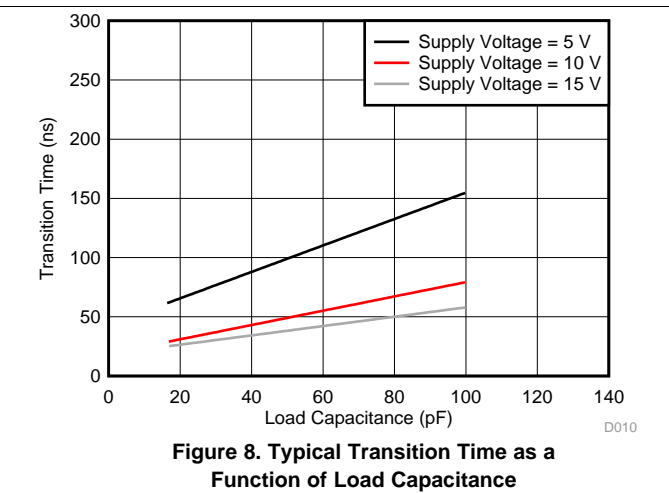
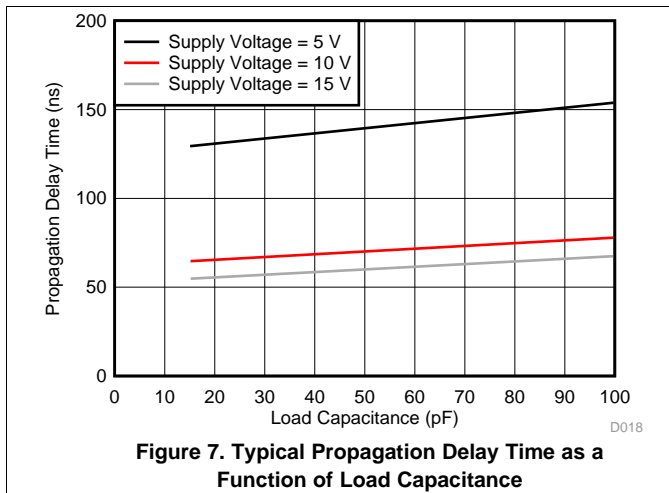

7 Parameter Measurement Information

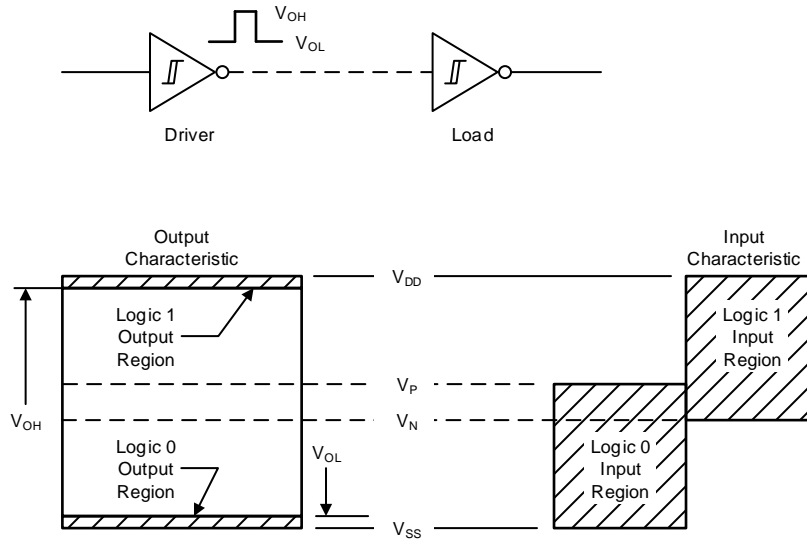
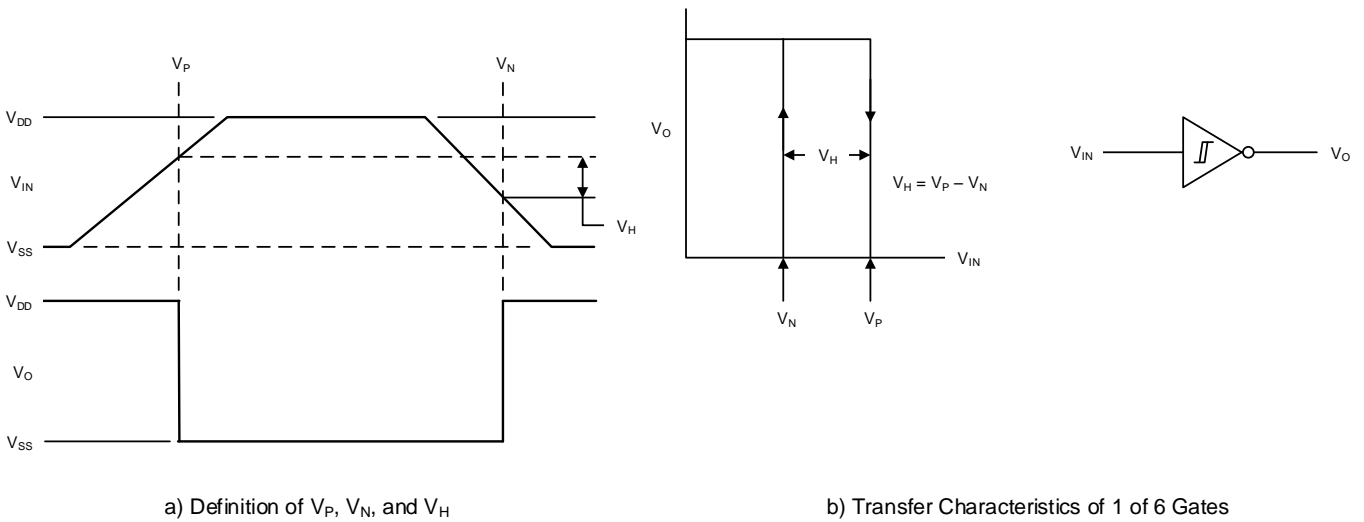

Figure 12. Input and Output Characteristics



a) Definition of V_P , V_N , and V_H

b) Transfer Characteristics of 1 of 6 Gates

Figure 13. Hysteresis Definition, Characteristics, and Test Set-Up

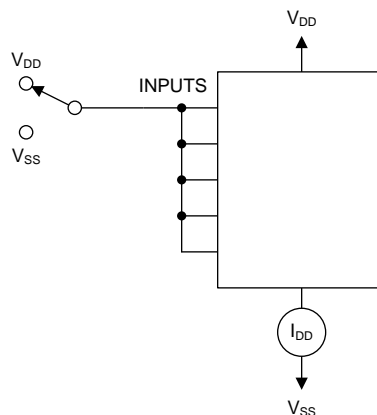

Figure 14. Quiescent Device Current Test Circuit

Parameter Measurement Information (continued)

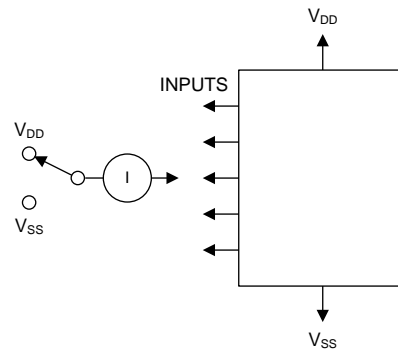

Figure 15. Input Current Test Circuit

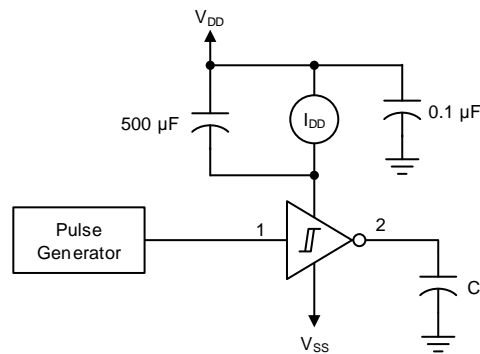

Figure 16. Dynamic Power Dissipation Test Circuit

8 Detailed Description

8.1 Overview

The CD40106B device contains six independent inverters with schmitt trigger inputs.. They perform the Boolean function $Y = \overline{A}$ in positive logic.

Schmitt-Trigger inputs are designed to provide a minimum separation between positive and negative switching thresholds. This allows for noisy or slow inputs that would cause problems such as oscillation or excessive current consumption.

8.2 Functional Block Diagram

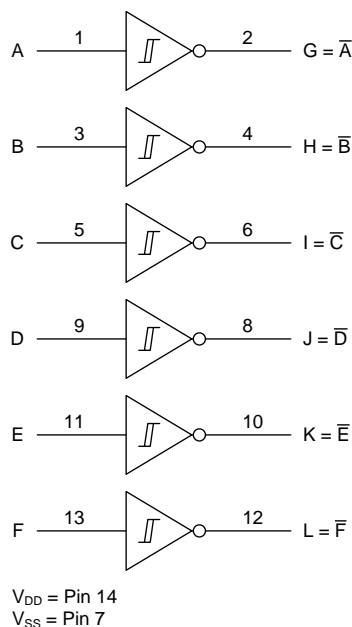

Copyright © 2017, Texas Instruments Incorporated

8.3 Feature Description

The CD40106B has standardized symmetrical output characteristics and a wide operating voltage from 3 V to 18 V with quiescent current of 20 μA tested at 20 V. These devices have transition times of $t_{TLH} = t_{THL} = 50$ ns (typical) at 10 V. The operating temperature is from -55°C to $+125^{\circ}\text{C}$. Schmitt trigger inputs on this device support slow or noisy input signals.

8.4 Device Functional Modes

Table 1 lists the functional modes of the CD40106B.

Table 1. Function Table

INPUT	OUTPUT
H	L
L	H

9 Application and Implementation

NOTE

Information in the following applications sections is not part of the TI component specification, and TI does not warrant its accuracy or completeness. TI's customers are responsible for determining suitability of components for their purposes. Customers should validate and test their design implementation to confirm system functionality.

9.1 Application Information

The CD40106B device is a Schmitt-Trigger input device that can be used for a multitude of inverting buffer type functions. The application shown here takes advantage of the Schmitt-Trigger inputs to produce a square wave output from a sine wave input.

9.2 Typical Applications

9.2.1 Wave Shaper

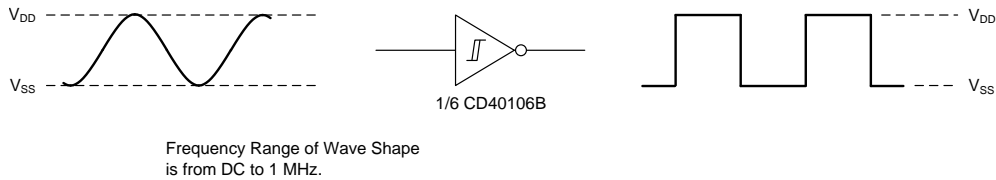

Copyright © 2017, Texas Instruments Incorporated

Figure 17. Wave Shaper Schematic

9.2.1.1 Design Requirements

Take care to avoid bus contention, because it can drive currents that would exceed maximum limits. Parallel output drive can create fast edges into light loads so consider routing and load conditions to prevent ringing.

9.2.1.2 Detailed Design Procedure

The recommended input conditions for Figure 17 includes specified high and low levels (see V_P and V_N in *Electrical Characteristics: Static*). Inputs are not overvoltage tolerant and must be below V_{CC} level because of the presence of input clamp diodes to VCC.

The recommended output condition for the CD40106B application includes specific load currents. Load currents must be limited so as to not exceed the total power (continuous current through VCC or GND) for the device. These limits are in the *Absolute Maximum Ratings*. Outputs must not be pulled above V_{CC} .

9.2.1.3 Application Curve

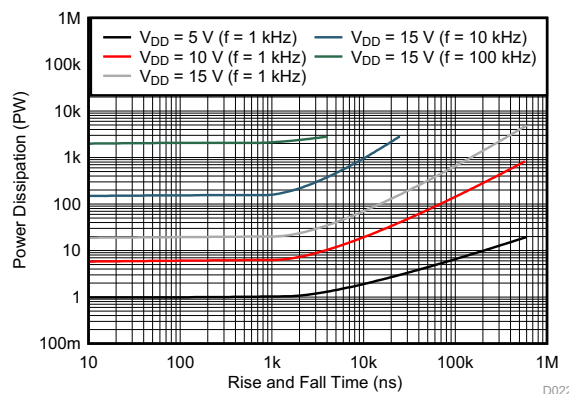
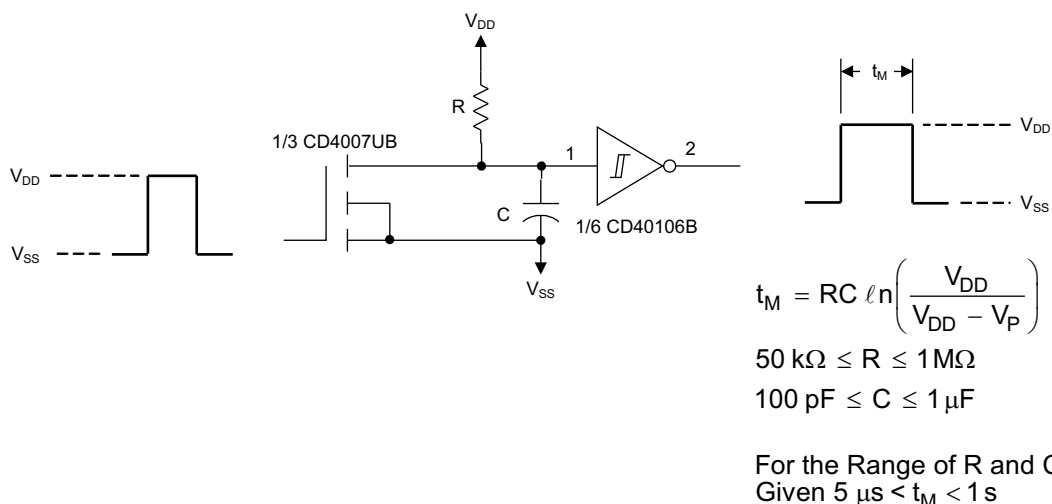

Figure 18. Typical Power Dissipation as a Function of Rise and Fall Times

Typical Applications (continued)

9.2.2 Monostable Multivibrator

The timing of the monostable multivibrator circuit can be set by following the equations shown in [Figure 19](#).



Copyright © 2016, Texas Instruments Incorporated

Figure 19. Monostable Multivibrator Schematic and Equations

9.2.3 Astable Multivibrator

The timing of the astable multivibrator circuit can be set by following the equations shown in [Figure 20](#).

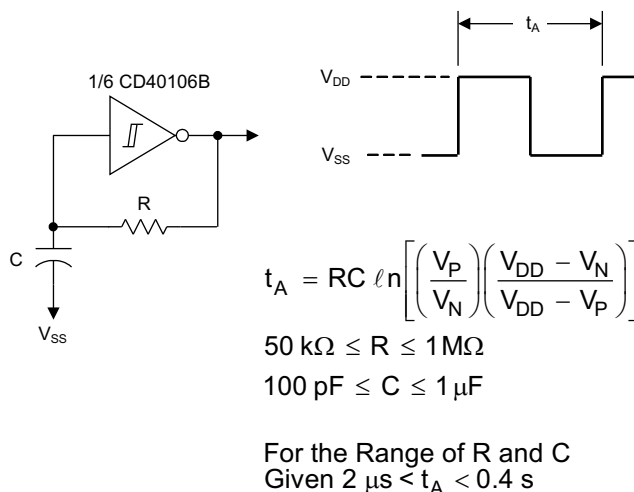

Copyright © 2016, Texas Instruments Incorporated

Figure 20. Astable Multivibrator Schematic and Equations

10 Power Supply Recommendations

The power supply can be any voltage between the minimum and maximum supply voltage rating located in the [Recommended Operating Conditions](#). The V_{CC} terminal must have a good bypass capacitor to prevent power disturbance. A 0.1- μF capacitor is recommended to be used on the V_{CC} terminal, and it must be placed as close as possible to the pin for best results.

11 Layout

11.1 Layout Guidelines

When using multiple bit logic devices, inputs must never float. In many cases, functions or parts of functions of digital logic devices are unused, for example, when only two inputs of a triple-input AND gate are used or only three of the four buffer gates are used. Such inputs must not be left unconnected because the undefined voltages at the outside connections result in undefined operational states. All unused inputs of digital logic devices must be connected to a high or low bias to prevent them from floating. The logic level that must be applied to any particular unused input depends on the function of the device. Generally they are tied to GND or V_{CC} , whichever makes more sense or is more convenient. Floating outputs are generally acceptable, unless the part is a transceiver.

11.2 Layout Example

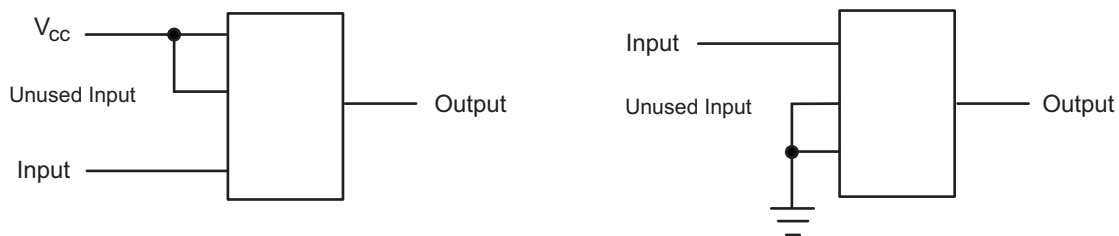

Figure 21. Layout Diagram

Layout Example (continued)

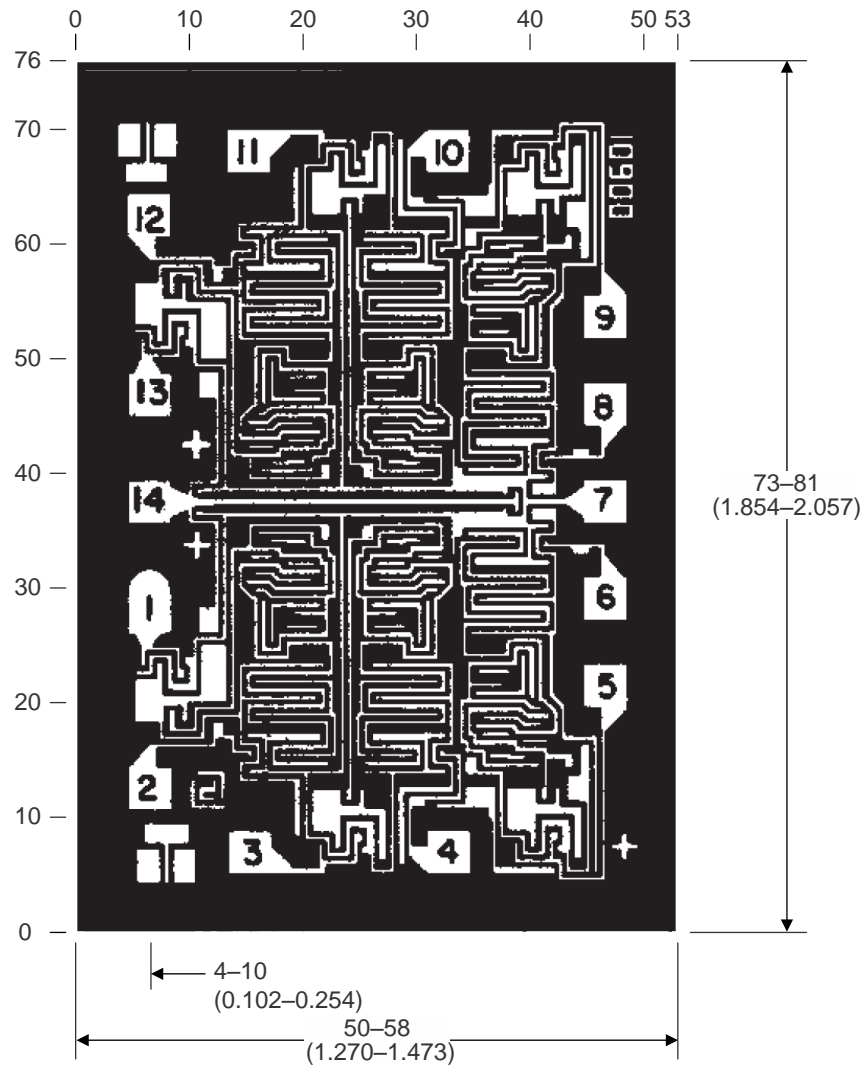

Figure 22. Dimensions and Pad Layout for CD40106BH

12 Device and Documentation Support

12.1 Receiving Notification of Documentation Updates

To receive notification of documentation updates, navigate to the device product folder on ti.com. In the upper right corner, click on *Alert me* to register and receive a weekly digest of any product information that has changed. For change details, review the revision history included in any revised document.

12.2 Community Resources

The following links connect to TI community resources. Linked contents are provided "AS IS" by the respective contributors. They do not constitute TI specifications and do not necessarily reflect TI's views; see TI's [Terms of Use](#).

TI E2E™ Online Community *TI's Engineer-to-Engineer (E2E) Community*. Created to foster collaboration among engineers. At e2e.ti.com, you can ask questions, share knowledge, explore ideas and help solve problems with fellow engineers.

Design Support *TI's Design Support* Quickly find helpful E2E forums along with design support tools and contact information for technical support.

12.3 Trademarks

E2E is a trademark of Texas Instruments.
All other trademarks are the property of their respective owners.

12.4 Electrostatic Discharge Caution



These devices have limited built-in ESD protection. The leads should be shorted together or the device placed in conductive foam during storage or handling to prevent electrostatic damage to the MOS gates.

12.5 Glossary

[SLYZ022](#) — *TI Glossary*.

This glossary lists and explains terms, acronyms, and definitions.

13 Mechanical, Packaging, and Orderable Information

The following pages include mechanical, packaging, and orderable information. This information is the most current data available for the designated devices. This data is subject to change without notice and revision of this document. For browser-based versions of this data sheet, refer to the left-hand navigation.

PACKAGING INFORMATION

Orderable Device	Status (1)	Package Type	Package Drawing	Pins	Package Qty	Eco Plan (2)	Lead finish/ Ball material (6)	MSL Peak Temp (3)	Op Temp (°C)	Device Marking (4/5)	Samples
CD40106BE	ACTIVE	PDIP	N	14	25	RoHS & Green	NIPDAU	N / A for Pkg Type	-55 to 125	CD40106BE	Samples
CD40106BEE4	ACTIVE	PDIP	N	14	25	RoHS & Green	NIPDAU	N / A for Pkg Type	-55 to 125	CD40106BE	Samples
CD40106BF	ACTIVE	CDIP	J	14	25	Non-RoHS & Green	SNPB	N / A for Pkg Type	-55 to 125	CD40106BF	Samples
CD40106BF3A	ACTIVE	CDIP	J	14	25	Non-RoHS & Green	SNPB	N / A for Pkg Type	-55 to 125	CD40106BF3A	Samples
CD40106BM	ACTIVE	SOIC	D	14	50	RoHS & Green	NIPDAU	Level-1-260C-UNLIM	-55 to 125	CD40106BM	Samples
CD40106BM96	ACTIVE	SOIC	D	14	2500	RoHS & Green	NIPDAU	Level-1-260C-UNLIM	-55 to 125	CD40106BM	Samples
CD40106BM96E4	ACTIVE	SOIC	D	14	2500	RoHS & Green	NIPDAU	Level-1-260C-UNLIM	-55 to 125	CD40106BM	Samples
CD40106BM96G4	ACTIVE	SOIC	D	14	2500	RoHS & Green	NIPDAU	Level-1-260C-UNLIM	-55 to 125	CD40106BM	Samples
CD40106BMG4	ACTIVE	SOIC	D	14	50	RoHS & Green	NIPDAU	Level-1-260C-UNLIM	-55 to 125	CD40106BM	Samples
CD40106BMT	OBSOLETE	SOIC	D	14		TBD	Call TI	Call TI	-55 to 125	CD40106BM	
CD40106BNSR	ACTIVE	SO	NS	14	2000	RoHS & Green	NIPDAU	Level-1-260C-UNLIM	-55 to 125	CD40106B	Samples
CD40106BPW	OBSOLETE	TSSOP	PW	14		TBD	Call TI	Call TI	-55 to 125	CM0106B	
CD40106BPWR	ACTIVE	TSSOP	PW	14	2000	RoHS & Green	NIPDAU	Level-1-260C-UNLIM	-55 to 125	CM0106B	Samples

(1) The marketing status values are defined as follows:

ACTIVE: Product device recommended for new designs.

LIFEBUY: TI has announced that the device will be discontinued, and a lifetime-buy period is in effect.

NRND: Not recommended for new designs. Device is in production to support existing customers, but TI does not recommend using this part in a new design.

PREVIEW: Device has been announced but is not in production. Samples may or may not be available.

OBSOLETE: TI has discontinued the production of the device.

(2) **RoHS:** TI defines "RoHS" to mean semiconductor products that are compliant with the current EU RoHS requirements for all 10 RoHS substances, including the requirement that RoHS substance do not exceed 0.1% by weight in homogeneous materials. Where designed to be soldered at high temperatures, "RoHS" products are suitable for use in specified lead-free processes. TI may reference these types of products as "Pb-Free".

RoHS Exempt: TI defines "RoHS Exempt" to mean products that contain lead but are compliant with EU RoHS pursuant to a specific EU RoHS exemption.

Green: TI defines "Green" to mean the content of Chlorine (Cl) and Bromine (Br) based flame retardants meet JS709B low halogen requirements of <=1000ppm threshold. Antimony trioxide based flame retardants must also meet the <=1000ppm threshold requirement.

(3) MSL, Peak Temp. - The Moisture Sensitivity Level rating according to the JEDEC industry standard classifications, and peak solder temperature.

(4) There may be additional marking, which relates to the logo, the lot trace code information, or the environmental category on the device.

(5) Multiple Device Markings will be inside parentheses. Only one Device Marking contained in parentheses and separated by a "~" will appear on a device. If a line is indented then it is a continuation of the previous line and the two combined represent the entire Device Marking for that device.

(6) Lead finish/Ball material - Orderable Devices may have multiple material finish options. Finish options are separated by a vertical ruled line. Lead finish/Ball material values may wrap to two lines if the finish value exceeds the maximum column width.

Important Information and Disclaimer:The information provided on this page represents TI's knowledge and belief as of the date that it is provided. TI bases its knowledge and belief on information provided by third parties, and makes no representation or warranty as to the accuracy of such information. Efforts are underway to better integrate information from third parties. TI has taken and continues to take reasonable steps to provide representative and accurate information but may not have conducted destructive testing or chemical analysis on incoming materials and chemicals. TI and TI suppliers consider certain information to be proprietary, and thus CAS numbers and other limited information may not be available for release.

In no event shall TI's liability arising out of such information exceed the total purchase price of the TI part(s) at issue in this document sold by TI to Customer on an annual basis.

OTHER QUALIFIED VERSIONS OF CD40106B, CD40106B-MIL :

- Catalog : [CD40106B](#)
- Military : [CD40106B-MIL](#)

NOTE: Qualified Version Definitions:

- Catalog - TI's standard catalog product
- Military - QML certified for Military and Defense Applications

TAPE AND REEL INFORMATION

QUADRANT ASSIGNMENTS FOR PIN 1 ORIENTATION IN TAPE

*All dimensions are nominal

Device	Package Type	Package Drawing	Pins	SPQ	Reel Diameter (mm)	Reel Width W1 (mm)	A0 (mm)	B0 (mm)	K0 (mm)	P1 (mm)	W (mm)	Pin1 Quadrant
CD40106BM96	SOIC	D	14	2500	330.0	16.4	6.5	9.0	2.1	8.0	16.0	Q1
CD40106BM96G4	SOIC	D	14	2500	330.0	16.4	6.5	9.0	2.1	8.0	16.0	Q1
CD40106BNSR	SO	NS	14	2000	330.0	16.4	8.2	10.5	2.5	12.0	16.0	Q1
CD40106BPWR	TSSOP	PW	14	2000	330.0	12.4	6.9	5.6	1.6	8.0	12.0	Q1

TAPE AND REEL BOX DIMENSIONS



*All dimensions are nominal

Device	Package Type	Package Drawing	Pins	SPQ	Length (mm)	Width (mm)	Height (mm)
CD40106BM96	SOIC	D	14	2500	356.0	356.0	35.0
CD40106BM96G4	SOIC	D	14	2500	356.0	356.0	35.0
CD40106BNSR	SO	NS	14	2000	356.0	356.0	35.0
CD40106BPWR	TSSOP	PW	14	2000	356.0	356.0	35.0

TUBE

*All dimensions are nominal

Device	Package Name	Package Type	Pins	SPQ	L (mm)	W (mm)	T (μm)	B (mm)
CD40106BE	N	PDIP	14	25	506	13.97	11230	4.32
CD40106BE	N	PDIP	14	25	506	13.97	11230	4.32
CD40106BEE4	N	PDIP	14	25	506	13.97	11230	4.32
CD40106BEE4	N	PDIP	14	25	506	13.97	11230	4.32
CD40106BM	D	SOIC	14	50	506.6	8	3940	4.32
CD40106BMG4	D	SOIC	14	50	506.6	8	3940	4.32

D0014A



PACKAGE OUTLINE

SOIC - 1.75 mm max height

SMALL OUTLINE INTEGRATED CIRCUIT



NOTES:

1. All linear dimensions are in millimeters. Dimensions in parenthesis are for reference only. Dimensioning and tolerancing per ASME Y14.5M.
2. This drawing is subject to change without notice.
3. This dimension does not include mold flash, protrusions, or gate burrs. Mold flash, protrusions, or gate burrs shall not exceed 0.15 mm, per side.
4. This dimension does not include interlead flash. Interlead flash shall not exceed 0.43 mm, per side.
5. Reference JEDEC registration MS-012, variation AB.

EXAMPLE BOARD LAYOUT

D0014A

SOIC - 1.75 mm max height

SMALL OUTLINE INTEGRATED CIRCUIT



LAND PATTERN EXAMPLE
SCALE:8X



SOLDER MASK DETAILS

4220718/A 09/2016

NOTES: (continued)

- 6. Publication IPC-7351 may have alternate designs.
- 7. Solder mask tolerances between and around signal pads can vary based on board fabrication site.

EXAMPLE STENCIL DESIGN

D0014A

SOIC - 1.75 mm max height

SMALL OUTLINE INTEGRATED CIRCUIT



SOLDER PASTE EXAMPLE
BASED ON 0.125 mm THICK STENCIL
SCALE:8X

4220718/A 09/2016

NOTES: (continued)

8. Laser cutting apertures with trapezoidal walls and rounded corners may offer better paste release. IPC-7525 may have alternate design recommendations.
9. Board assembly site may have different recommendations for stencil design.

MECHANICAL DATA

NS (R-PDSO-G**)

PLASTIC SMALL-OUTLINE PACKAGE

14-PINS SHOWN



- NOTES:
- A. All linear dimensions are in millimeters.
 - B. This drawing is subject to change without notice.
 - C. Body dimensions do not include mold flash or protrusion, not to exceed 0,15.

J 14

GENERIC PACKAGE VIEW
CDIP - 5.08 mm max height
CERAMIC DUAL IN LINE PACKAGE



Images above are just a representation of the package family, actual package may vary.
Refer to the product data sheet for package details.

4040083-5/G

J0014A



PACKAGE OUTLINE

CDIP - 5.08 mm max height

CERAMIC DUAL IN LINE PACKAGE



4214771/A 05/2017

NOTES:

1. All controlling linear dimensions are in inches. Dimensions in brackets are in millimeters. Any dimension in brackets or parenthesis are for reference only. Dimensioning and tolerancing per ASME Y14.5M.
2. This drawing is subject to change without notice.
3. This package is hermetically sealed with a ceramic lid using glass frit.
4. Index point is provided on cap for terminal identification only and on press ceramic glass frit seal only.
5. Falls within MIL-STD-1835 and GDIP1-T14.

EXAMPLE BOARD LAYOUT

J0014A

CDIP - 5.08 mm max height

CERAMIC DUAL IN LINE PACKAGE



LAND PATTERN EXAMPLE
NON-SOLDER MASK DEFINED
SCALE: 5X



4214771/A 05/2017

N (R-PDIP-T**)

PLASTIC DUAL-IN-LINE PACKAGE

16 PINS SHOWN



- NOTES:
- A. All linear dimensions are in inches (millimeters).
 - B. This drawing is subject to change without notice.
 - Falls within JEDEC MS-001, except 18 and 20 pin minimum body length (Dim A).
 - The 20 pin end lead shoulder width is a vendor option, either half or full width.

4040049/E 12/2002

PW0014A

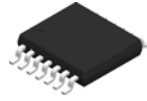

PACKAGE OUTLINE

TSSOP - 1.2 mm max height

SMALL OUTLINE PACKAGE



4220202/B 12/2023

NOTES:

1. All linear dimensions are in millimeters. Any dimensions in parenthesis are for reference only. Dimensioning and tolerancing per ASME Y14.5M.
2. This drawing is subject to change without notice.
3. This dimension does not include mold flash, protrusions, or gate burrs. Mold flash, protrusions, or gate burrs shall not exceed 0.15 mm per side.
4. This dimension does not include interlead flash. Interlead flash shall not exceed 0.25 mm per side.
5. Reference JEDEC registration MO-153.

EXAMPLE STENCIL DESIGN

PW0014A

TSSOP - 1.2 mm max height

SMALL OUTLINE PACKAGE



SOLDER PASTE EXAMPLE
BASED ON 0.125 mm THICK STENCIL
SCALE: 10X

4220202/B 12/2023

NOTES: (continued)

8. Laser cutting apertures with trapezoidal walls and rounded corners may offer better paste release. IPC-7525 may have alternate design recommendations.
9. Board assembly site may have different recommendations for stencil design.

IMPORTANT NOTICE AND DISCLAIMER

TI PROVIDES TECHNICAL AND RELIABILITY DATA (INCLUDING DATA SHEETS), DESIGN RESOURCES (INCLUDING REFERENCE DESIGNS), APPLICATION OR OTHER DESIGN ADVICE, WEB TOOLS, SAFETY INFORMATION, AND OTHER RESOURCES "AS IS" AND WITH ALL FAULTS, AND DISCLAIMS ALL WARRANTIES, EXPRESS AND IMPLIED, INCLUDING WITHOUT LIMITATION ANY IMPLIED WARRANTIES OF MERCHANTABILITY, FITNESS FOR A PARTICULAR PURPOSE OR NON-INFRINGEMENT OF THIRD PARTY INTELLECTUAL PROPERTY RIGHTS.

These resources are intended for skilled developers designing with TI products. You are solely responsible for (1) selecting the appropriate TI products for your application, (2) designing, validating and testing your application, and (3) ensuring your application meets applicable standards, and any other safety, security, regulatory or other requirements.

These resources are subject to change without notice. TI grants you permission to use these resources only for development of an application that uses the TI products described in the resource. Other reproduction and display of these resources is prohibited. No license is granted to any other TI intellectual property right or to any third party intellectual property right. TI disclaims responsibility for, and you will fully indemnify TI and its representatives against, any claims, damages, costs, losses, and liabilities arising out of your use of these resources.

TI's products are provided subject to [TI's Terms of Sale](#) or other applicable terms available either on [ti.com](https://www.ti.com) or provided in conjunction with such TI products. TI's provision of these resources does not expand or otherwise alter TI's applicable warranties or warranty disclaimers for TI products.

TI objects to and rejects any additional or different terms you may have proposed.

Mailing Address: Texas Instruments, Post Office Box 655303, Dallas, Texas 75265
Copyright © 2024, Texas Instruments Incorporated