

## CD40x7B CMOS 模拟多用复用器或多路信号分离器

### 1 特性

- 高电压类型 ( 20V 额定值 )
  - CD4067B – 单路 16 通道多路复用器或多路信号分离器
- 低导通电阻：在  $V_{DD} - V_{SS} = 15V$  时的  $15V_{P-P}$  信号输入范围内为  $125\Omega$  ( 典型值 )
- 高关断电阻：在  $V_{DD} - V_{SS} = 10V$  时，通道漏电流为  $\pm 10pA$  ( 典型值 )
- 匹配的开关特性：  $V_{DD} - V_{SS} = 15V$  时  $R_{ON} = 5\Omega$  ( 典型值 )
- 在所有数字控制输入和电源条件下具有超低静态功率损耗：
  - $V_{DD} - V_{SS} = 10V$  时为  $0.2\mu W$  ( 典型值 )
- 二进制地址片上解码
- 5V、10V 和 15V 参数额定值
- 针对 20V 下的静态电流进行了 100% 测试
- 标准化对称输出特性
- 在全封装温度范围内，18V 时的最大输入电流为  $1\mu A$ ：18V 和  $25^{\circ}C$  时为  $100nA$
- 符合 JEDEC 第 13-B 号暂行标准用于描述“B”系列 CMOS 器件的标准规范的全部要求

### 2 应用

- 模拟信号和数字多路复用
- 传输门逻辑实施
- 模数和数模转换
- 信号门控

### 3 说明

CD40x7B CMOS 模拟多路复用器或多路信号分离器是数控模拟开关，具有低导通阻抗、低关断漏电流和内部地址解码。当这些器件用作多路信号分离器时，通道 IN 或 OUT 端子是输出，公共 OUT 或 IN 端子是输入。此外，导通电阻在整个输入信号范围内相对恒定。

CD4067B 是一款 16 通道多路复用器，具有四个二进制控制输入：A、B、C、D 和抑制输入，其排列方式使任意输入组合均可选择一个开关。

抑制输入端的逻辑“1”会将所有通道关闭。

CD40x7B 类型采用 24 引线气密性双列直插式陶瓷封装 ( 后缀为 F3A )、24 引线双列直插式塑料封装 ( 后缀为 E )、24 引线小外形封装 ( 后缀为 M、M96 和 NSR ) 和 24 引线薄型紧缩小外形封装 ( 后缀为 P 和 PWR )。

#### 器件信息

| 器件型号    | 通道               | 封装 <sup>(1)</sup> |
|---------|------------------|-------------------|
| CD4067B | 2 通道 8:1 差分多路复用器 | PW ( TSSOP , 24 ) |
|         |                  | DW ( SOIC , 24 )  |

(1) 有关更多信息，请参阅节 11。



**CD4067B, CD4097B**

ZHCSWN9D – JUNE 2003 – REVISED AUGUST 2024

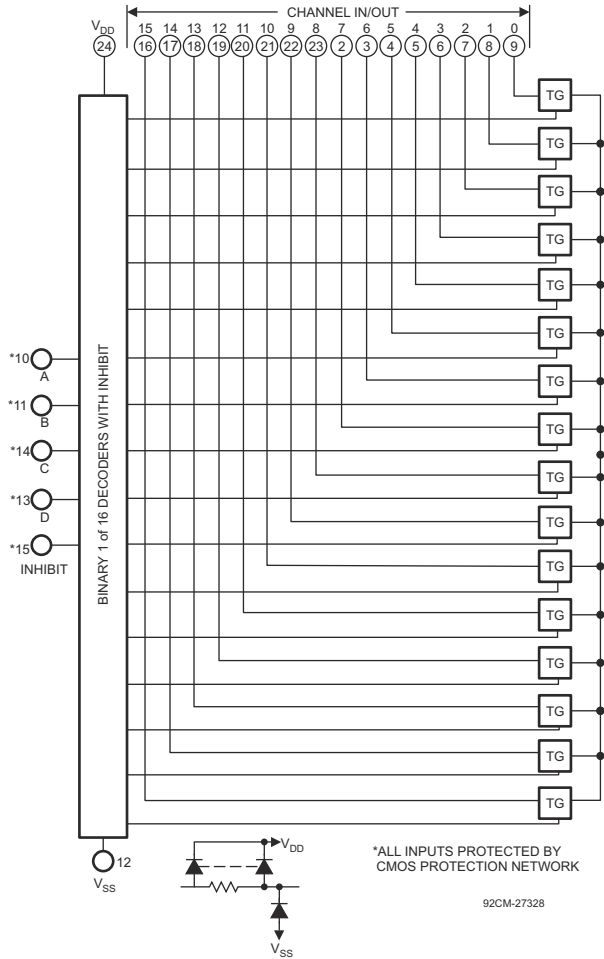

**CD4067 逻辑图**

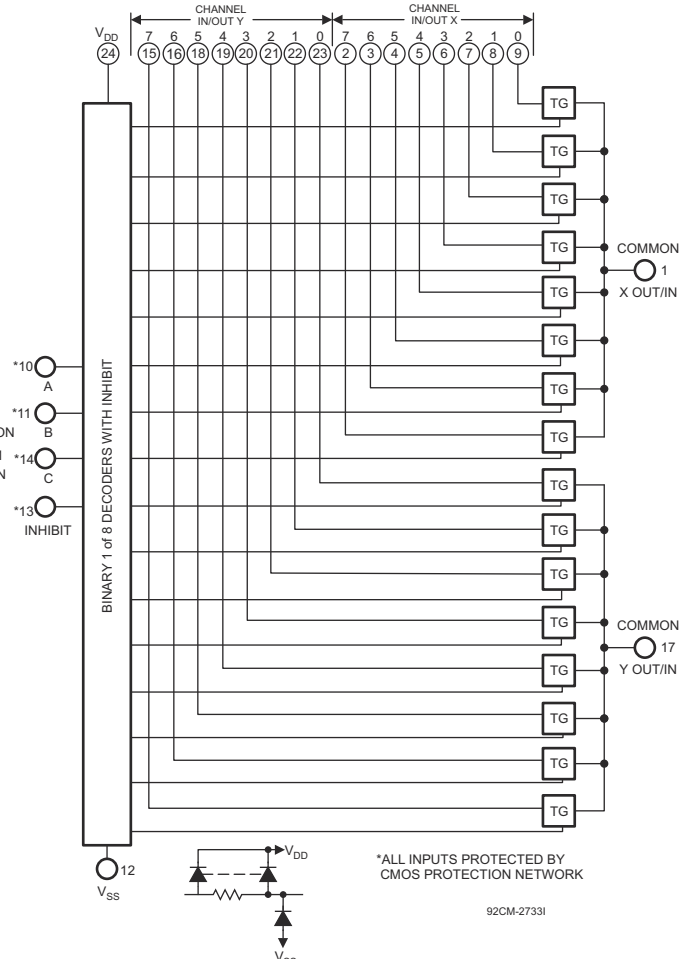

**CD4097 逻辑图**

## Table of Contents

|  |    |  |    |
|--|----|--|----|
| <b>1 特性</b> .....                                | 1  | 7.1 Functional Block Diagram.....                                | 12 |
| <b>2 应用</b> .....                                | 1  | 7.2 Device Functional Modes.....                                 | 12 |
| <b>3 说明</b> .....                                | 1  | <b>8 Application and Implementation</b> .....                    | 14 |
| <b>4 Pin Configuration and Functions</b> .....   | 4  | 8.1 Application Information.....                                 | 14 |
| <b>5 Specifications</b> .....                    | 5  | 8.2 Typical Application.....                                     | 14 |
| 5.1 Absolute Maximum Ratings.....                | 5  | <b>9 Device and Documentation Support</b> .....                  | 15 |
| 5.2 ESD Ratings.....                             | 5  | 9.1 接收文档更新通知.....  | 15 |
| 5.3 Recommended Operating Conditions.....        | 5  | 9.2 支持资源.....  | 15 |
| 5.4 Thermal Information.....                     | 6  | 9.3 Trademarks.....  | 15 |
| 5.5 Electrical Characteristics.....              | 6  | 9.4 静电放电警告.....  | 15 |
| 5.6 AC Performance Characteristics.....          | 8  | 9.5 术语表.....   | 15 |
| 5.7 Typical Characteristics.....                 | 8  | <b>10 Revision History</b> .....                                 | 15 |
| <b>6 Parameter Measurement Information</b> ..... | 9  | <b>11 Mechanical, Packaging, and Orderable Information</b> ..... | 15 |
| 6.1 Test Circuits.....                           | 9  |  |    |
| <b>7 Detailed Description</b> .....              | 12 |  |    |

## 4 Pin Configuration and Functions



图 4-1. CD4067B 24 Pins (Top View)

表 4-1. Function Table

| CD4067 TRUTH TABLE |   |   |   |     |                  |
|--------------------|---|---|---|-----|------------------|
| A                  | B | C | D | inh | Selected Channel |
| X                  | X | X | X | 1   | None             |
| 0                  | 0 | 0 | 0 | 0   | 0                |
| 1                  | 0 | 0 | 0 | 0   | 1                |
| 0                  | 1 | 0 | 0 | 0   | 2                |
| 1                  | 1 | 0 | 0 | 0   | 3                |
| 0                  | 0 | 1 | 0 | 0   | 4                |
| 1                  | 0 | 1 | 0 | 0   | 5                |
| 0                  | 1 | 1 | 0 | 0   | 6                |
| 1                  | 1 | 1 | 0 | 0   | 7                |
| 0                  | 0 | 0 | 1 | 0   | 8                |
| 1                  | 0 | 0 | 1 | 0   | 9                |
| 0                  | 1 | 0 | 1 | 0   | 10               |
| 1                  | 1 | 0 | 1 | 0   | 11               |
| 0                  | 0 | 1 | 1 | 0   | 12               |
| 1                  | 0 | 1 | 1 | 0   | 13               |
| 0                  | 1 | 1 | 1 | 0   | 14               |
| 1                  | 1 | 1 | 1 | 0   | 15               |

表 4-2. Function Table

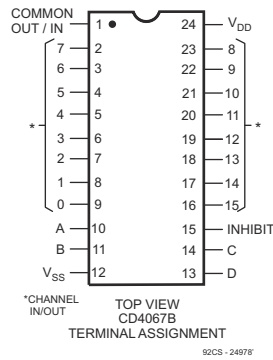
| CD4097 TRUTH TABLE |   |   |     |                  |
|--------------------|---|---|-----|------------------|
| A                  | B | C | inh | Selected Channel |
| X                  | X | X | 1   | None             |
| 0                  | 0 | 0 | 0   | 0X, 0Y           |
| 1                  | 0 | 0 | 0   | 1X, 1Y           |
| 0                  | 1 | 0 | 0   | 2X, 2Y           |
| 1                  | 1 | 0 | 0   | 3X, 3Y           |
| 0                  | 0 | 1 | 0   | 4X, 4Y           |
| 1                  | 0 | 1 | 0   | 5X, 5Y           |
| 0                  | 1 | 1 | 0   | 6X, 6Y           |
| 1                  | 1 | 1 | 0   | 7X, 7Y           |

## 5 Specifications

### 5.1 Absolute Maximum Ratings

over operating free-air temperature range (unless otherwise noted)<sup>(1) (2)</sup>

|                       |   | MIN          | MAX          | UNIT |
|-----------------------|---|--------------|--------------|------|
| $V_{DD} - V_{SS}$     | Supply voltage  |              | 20           | V    |
| $V_{DD}$              |   | -0.5         | 20           | V    |
| $V_{SS}$              |   | -20          | 0.5          | V    |
| $I_{SEL}$ or $I_{EN}$ | Logic control input pin current ( $\overline{EN}$ , Ax, SELx) | -30          | 30           | mA   |
| $V_S$ or $V_D$        | Source or drain voltage (Sx, D)                               | $V_{SS}-0.5$ | $V_{DD}+0.5$ | V    |
| $I_S$ or $I_D$ (CONT) | Source or drain continuous current (Sx, D)                    | -20          | 20           | mA   |
| $T_J$                 | Junction temperature  |              | 150          | °C   |
| $T_{stg}$             | Storage temperature   | -65          | 150          | °C   |

- (1) Stresses beyond those listed under *Absolute Maximum Rating* may cause permanent damage to the device. These are stress ratings only, which do not imply functional operation of the device at these or any other conditions beyond those indicated under *Recommended Operating Condition*. Exposure to absolute-maximum-rated conditions for extended periods may affect device reliability.
- (2) All voltages are with respect to ground, unless otherwise specified.

### 5.2 ESD Ratings

|             |                         | VALUE  | UNIT  |
|-------------|-------------------------|--|-------|
| $V_{(ESD)}$ | Electrostatic discharge | Human body model (HBM), per ANSI/ESDA/ JEDEC JS-001, all pins <sup>(1)</sup>             | ±2000 |
|             |                         | Charged device model (CDM), per JEDEC specification JESD22-C101, all pins <sup>(2)</sup> | ±200  |

- (1) JEDEC document JEP155 states that 500V HBM allows safe manufacturing with a standard ESD control process.
- (2) JEDEC document JEP157 states that 250V CDM allows safe manufacturing with a standard ESD control process.

### 5.3 Recommended Operating Conditions

over operating free-air temperature range (unless otherwise noted)

|                                  |  | MIN      | NOM | MAX      | UNIT |
|----------------------------------|--|----------|-----|----------|------|
| $V_{DD} - V_{SS}$ <sup>(1)</sup> | Power supply voltage differential                              | 3        |     | 18       | V    |
| $V_{DD}$                         | Positive power supply voltage                                  | 3        |     | 18       | V    |
| $V_S$ or $V_D$                   | Signal path input/output voltage (source or drain pin) (Sx, D) | $V_{SS}$ |     | $V_{DD}$ | V    |
| $V_{SEL}$ or $V_{EN}$            | Address or enable pin voltage                                  | 0        |     | $V_{DD}$ | V    |
| $I_S$ or $I_D$ (CONT)            | Source or drain continuous current (Sx, D)                     | -10      |     | 10       | mA   |
| $T_A$                            | Ambient temperature  | -55      |     | 125      | °C   |

- (1)  $V_{DD}$  and  $V_{SS}$  can be any value as long as  $3V \leq (V_{DD} - V_{SS}) \leq 24V$ , and the minimum  $V_{DD}$  is met.

### 5.4 Thermal Information

| THERMAL METRIC <sup>(1)</sup> |  | CD406x   | CD406x     | UNIT |
|-------------------------------|--|----------|------------|------|
|                               |  | D (SOIC) | PW (TSSOP) |      |
|                               |  | 14 PINS  | 14 PINS    |      |
| R <sub>θJA</sub>              | Junction-to-ambient thermal resistance       | 109.7    | 101.8      | °C/W |
| R <sub>θJC(top)</sub>         | Junction-to-case (top) thermal resistance    | 69.4     | 44.3       | °C/W |
| R <sub>θJB</sub>              | Junction-to-board thermal resistance         | 67.9     | 68.2       | °C/W |
| Ψ <sub>JT</sub>               | Junction-to-top characterization parameter   | 25.8     | 3.2        | °C/W |
| Ψ <sub>JB</sub>               | Junction-to-board characterization parameter | 67.1     | 67.6       | °C/W |

(1) For more information about traditional and new thermal metrics, see the [Semiconductor and IC Package Thermal Metrics](#) application report.

### 5.5 Electrical Characteristics

Over operating free-air temperature range, V<sub>SUPPLY</sub> = ±5V, and R<sub>L</sub> = 100Ω, (unless otherwise noted)<sup>(1)</sup>

| PARAMETER  | TEST CONDITIONS                   | TEST CONDITIONS  | TEST CONDITIONS        | TEST CONDITIONS        | MIN | TYP | MAX  | UNIT |    |     |     |
|--|-----------------------------------|--|------------------------|------------------------|-----|-----|------|------|----|-----|-----|
| <b>SIGNAL INPUTS (V<sub>IS</sub>) AND OUTPUTS (V<sub>OS</sub>)</b> |                                   |  |                        |                        |     |     |      |      |    |     |     |
| I <sub>DD</sub>  | Quiescent Device Current          | V <sub>IS</sub> = 0 to 5V<br>V <sub>DD</sub> = 5V  | T <sub>A</sub> = -55°C |                        |     |     |      | 13   | μA |     |     |
|  |                                   |  | T <sub>A</sub> = -40°C |                        |     |     |      | 13   |    |     |     |
|  |                                   |  | T <sub>A</sub> = 25°C  |                        |     | 5   | 14.5 |      |    |     |     |
|  |                                   |  | T <sub>A</sub> = 85°C  |                        |     |     | 150  |      |    |     |     |
|  |                                   |  | T <sub>A</sub> = 125°C |                        |     |     | 150  |      |    |     |     |
|  |                                   | V <sub>IS</sub> = 0 to 5V<br>V <sub>DD</sub> = 10V   | T <sub>A</sub> = -55°C |                        |     |     |      |      |    | 14  |     |
|  |                                   |  | T <sub>A</sub> = -40°C |                        |     |     |      |      |    | 14  |     |
|  |                                   |  | T <sub>A</sub> = 25°C  |                        |     | 6   | 15.5 |      |    |     |     |
|  |                                   |  | T <sub>A</sub> = 85°C  |                        |     |     | 300  |      |    |     |     |
|  |                                   |  | T <sub>A</sub> = 125°C |                        |     |     | 300  |      |    |     |     |
|  |                                   | V <sub>IS</sub> = 0 to 5V<br>V <sub>DD</sub> = 15V   | T <sub>A</sub> = -55°C |                        |     |     |      |      |    | 20  |     |
|  |                                   |  | T <sub>A</sub> = -40°C |                        |     |     |      |      |    | 20  |     |
|  |                                   |  | T <sub>A</sub> = 25°C  |                        |     | 6   | 20   |      |    |     |     |
|  |                                   |  | T <sub>A</sub> = 85°C  |                        |     |     | 600  |      |    |     |     |
|  |                                   |  | T <sub>A</sub> = 125°C |                        |     |     | 600  |      |    |     |     |
|  |                                   | V <sub>IS</sub> = 0 to 5V<br>V <sub>DD</sub> = 20V   | T <sub>A</sub> = -55°C |                        |     |     |      |      |    | 100 |     |
|  |                                   |  | T <sub>A</sub> = -40°C |                        |     |     |      |      |    | 100 |     |
|  |                                   |  | T <sub>A</sub> = 25°C  |                        |     | 7   | 100  |      |    |     |     |
|  |                                   |  | T <sub>A</sub> = 85°C  |                        |     |     | 3000 |      |    |     |     |
|  |                                   |  | T <sub>A</sub> = 125°C |                        |     |     | 3000 |      |    |     |     |
| r <sub>ON</sub>  | ON Resistance r <sub>ON</sub> Max | to (V <sub>DD</sub> -V <sub>SS</sub> )/2,<br>V <sub>C</sub> = V <sub>DD</sub> ,<br>R <sub>L</sub> = 10kΩ<br>returned V <sub>IS</sub> = V <sub>SS</sub><br>to V <sub>DD</sub> | V <sub>DD</sub> = 5V   | T <sub>A</sub> = -55°C |     |     |      | 800  | Ω  |     |     |
|  |                                   |  |                        | T <sub>A</sub> = -40°C |     |     |      | 850  |    |     |     |
|  |                                   |  |                        | T <sub>A</sub> = 25°C  |     |     | 470  | 1050 |    |     |     |
|  |                                   |  |                        | T <sub>A</sub> = 85°C  |     |     |      | 1200 |    |     |     |
|  |                                   |  |                        | T <sub>A</sub> = 125°C |     |     |      | 1300 |    |     |     |
|  |                                   |  | V <sub>DD</sub> = 10V  | T <sub>A</sub> = -55°C |     |     |      |      |    |     | 310 |
|  |                                   |  |                        | T <sub>A</sub> = -40°C |     |     |      |      |    |     | 330 |
|  |                                   |  |                        | T <sub>A</sub> = 25°C  |     |     | 180  | 400  |    |     |     |
|  |                                   |  |                        | T <sub>A</sub> = 85°C  |     |     |      | 520  |    |     |     |
|  |                                   |  |                        | T <sub>A</sub> = 125°C |     |     |      | 550  |    |     |     |
|  |                                   |  | V <sub>DD</sub> = 15V  | T <sub>A</sub> = -55°C |     |     |      |      |    |     | 200 |
|  |                                   |  |                        | T <sub>A</sub> = -40°C |     |     |      |      |    |     | 210 |
|  |                                   |  |                        | T <sub>A</sub> = 25°C  |     |     | 125  | 240  |    |     |     |
| T <sub>A</sub> = 85°C  |                                   |  |                        |                        | 300 |     |      |      |    |     |     |
| V <sub>DD</sub> = 15V  | T <sub>A</sub> = 125°C            |  |                        |                        |     |     | 320  |      |    |     |     |

## 5.5 Electrical Characteristics (续)

Over operating free-air temperature range,  $V_{SUPPLY} = \pm 5V$ , and  $R_L = 100\Omega$ , (unless otherwise noted)<sup>(1)</sup>

| PARAMETER  |   |   | TEST CONDITIONS   | TEST CONDITIONS                   | TEST CONDITIONS                   | TEST CONDITIONS                   | MIN       | TYP              | MAX  | UNIT     |
|--|---|---|---|-----------------------------------|-----------------------------------|-----------------------------------|-----------|------------------|------|----------|
| $\Delta R_{ON}$  | On-state resistance difference between any two switches |   | $R_L = 10k\Omega, V_C = V_{DD}$   | $V_{DD} = 5V$                     |                                   |                                   |           | 15               |      | $\Omega$ |
|  | On-state resistance difference between any two switches | On-state resistance difference between any two switches |   | $V_{DD} = 10V$                    |                                   |                                   |           | 10               |      |          |
|  | On-state resistance difference between any two switches | On-state resistance difference between any two switches |   | $V_{DD} = 15V$                    |                                   |                                   |           | 5                |      |          |
| OFF Channel Leakage Current: Any Channel OFF (Max) or ALL Channels OFF (COMMON OUT/IN) (Max) |   |   |   | $V_{DD} - V_{SS} = 18V$           | $T_A = -55^\circ C$               |                                   |           | $\pm 100$        | $nA$ |          |
|  |   |   |   |                                   | $T_A = -40^\circ C$               |                                   |           | $\pm 100$        |      |          |
|  |   |   |   |                                   | $T_A = 25^\circ C$                |                                   | $\pm 0.1$ | $\pm 100^{(2)}$  |      |          |
|  |   |   |   |                                   | $T_A = 85^\circ C$                |                                   |           | $\pm 1000^{(2)}$ |      |          |
|  |   |   |   |                                   | $T_A = 125^\circ C$               |                                   |           | $\pm 1000^{(2)}$ |      |          |
| $C_{IS}$   | Input capacitance                                       | $V_S = 0V$<br>$f = 1MHz$<br>CD4067                      | $V_{DD} = 5V, V_C = V_{SS} = -5V$   | $V_{DD} = 5V, V_C = V_{SS} = -5V$ | $V_{DD} = 5V, V_C = V_{SS} = -5V$ | $V_{DD} = 5V, V_C = V_{SS} = -5V$ |           | 5                |      | pF       |
| $C_{OS}$   | Output capacitance                                      | $V_S = 0V$<br>$f = 1MHz$<br>CD4067                      | $V_{DD} = 5V, V_C = V_{SS} = -5V$   | $V_{DD} = 5V, V_C = V_{SS} = -5V$ | $V_{DD} = 5V, V_C = V_{SS} = -5V$ | $V_{DD} = 5V, V_C = V_{SS} = -5V$ |           | 55               |      | pF       |
| $C_{OS}$   | Output capacitance                                      | $V_S = 0V$<br>$f = 1MHz$<br>CD4097                      | $V_{DD} = 5V, V_C = V_{SS} = -5V$   | $V_{DD} = 5V, V_C = V_{SS} = -5V$ | $V_{DD} = 5V, V_C = V_{SS} = -5V$ | $V_{DD} = 5V, V_C = V_{SS} = -5V$ |           | 35               |      | pF       |
| $C_{IOS}$  | Feed through  | $V_S = 0V$<br>$f = 1MHz$                                | $V_{DD} = 5V, V_C = V_{SS} = -5V$   | $V_{DD} = 5V, V_C = V_{SS} = -5V$ | $V_{DD} = 5V, V_C = V_{SS} = -5V$ | $V_{DD} = 5V, V_C = V_{SS} = -5V$ |           | 0.2              |      | pF       |
| $V_{IHC}$  | Control input, high voltage                             |   | See Figure 6-1  | $V_{DD} = 5V$                     |                                   |                                   |           |                  | 3.5  | V        |
|  |   |   |   | $V_{DD} = 10V$                    |                                   |                                   |           |                  | 7    | V        |
|  |   |   |   | $V_{DD} = 15V$                    |                                   |                                   |           |                  | 11   | V        |
| $V_{ILC}$  | Control input, low voltage (max)                        |   |   | $V_{DD} = 5V$                     |                                   |                                   |           | 1                |      | V        |
|  |   |   |   | $V_{DD} = 10V$                    |                                   |                                   |           | 1                |      | V        |
|  |   |   |   | $V_{DD} = 15V$                    |                                   |                                   |           | 1                |      | V        |
| $I_{IN}$   | Input current (max)                                     |   | $V_{IS} \leq V_{DD}, V_{DD} - V_{SS} = 18V, V_{CC} \leq V_{DD} - V_{SS}, V_{DD} = 18V$                                      | $T_A = -55^\circ C$               |                                   |                                   | -0.1      |                  | 1    | $\mu A$  |
|  |   |   |   | $T_A = -40^\circ C$               |                                   |                                   | -0.1      |                  | 1    |          |
|  | $T_A = 25^\circ C$                                      |   |   | -0.1                              | 0.0001                            | 1                                 |           |                  |      |          |
|  | $T_A = 85^\circ C$                                      |   |   | -1                                |                                   | 1                                 |           |                  |      |          |
|  | Input current (max)                                     | Input current (max)                                     |   | $T_A = 125^\circ C$               |                                   |                                   | -1        |                  | 1    |          |
| $C_{IN}$   | Input Capacitance                                       |   |   |                                   |                                   |                                   | 5         | 7.5              | pF   |          |
| BW   | -3dB cutoff frequency (switch on)                       | CD4067  | $V_C = V_{DD} = 5V, V_{SS} = -5V, V_{IS(p-p)} = 5V$ (sine wave centered on 0V), $R_L = 1k\Omega$ Common Out/In              |                                   |                                   |                                   |           | 14               |      | MHz      |
|  |   | CD4097  |   |                                   |                                   |                                   |           | 20               |      |          |
|  | -3dB cutoff frequency (switch on)                       |   | $V_C = V_{DD} = 5V, V_{SS} = -5V, V_{IS(p-p)} = 5V$ (sine wave centered on 0V), $R_L = 1k\Omega$ Any channel                |                                   |                                   |                                   |           | 60               |      |          |
| THD  | Total Harmonic Distortion                               | Total Harmonic Distortion                               | $V_C = V_{DD} = 5V, V_{SS} = 0V, V_{IS(p-p)} = 2V$ (sine wave centered on 0V), $R_L = 10k\Omega, f_{IS} = 1-kHz$ sine wave  |                                   |                                   |                                   |           | 0.3              |      | %        |
|  |   |   | $V_C = V_{DD} = 10V, V_{SS} = 0V, V_{IS(p-p)} = 3V$ (sine wave centered on 0V), $R_L = 10k\Omega, f_{IS} = 1-kHz$ sine wave |                                   |                                   |                                   |           | 0.2              |      |          |
|  |   |   | $V_C = V_{DD} = 15V, V_{SS} = 0V, V_{IS(p-p)} = 5V$ (sine wave centered on 0V), $R_L = 10k\Omega, f_{IS} = 1-kHz$ sine wave |                                   |                                   |                                   |           | 0.12             |      |          |
| OISO   | -40dB feed through frequency (switch off)               | CD4067  | $V_C = V_{DD} = 5V, V_{SS} = -5V, V_{IS(p-p)} = 5V$ (sine wave centered on 0V), $R_L = 1k\Omega$ Common Out/In              |                                   |                                   |                                   |           | 20               |      | MHz      |
|  |   | CD4097  |   |                                   |                                   |                                   |           | 12               |      |          |
|  | -40dB feed through frequency (switch off)               |   | $V_C = V_{DD} = 5V, V_{SS} = -5V, V_{IS(p-p)} = 5V$ (sine wave centered on 0V), $R_L = 1k\Omega$ Any channel                |                                   |                                   |                                   |           | 8                |      |          |
| XTALK  | -40dB crosstalk frequency                               | Any 2 Channels  |   |                                   |                                   |                                   |           | 1                |      | MHz      |
|  |   | CD4097 on Common  | $V_C = V_{DD} = 5V, V_{SS} = -5V, V_{IS(p-p)} = 5V$ (sine wave centered on 0V), $R_L = 1k\Omega$                            |                                   |                                   |                                   |           | 10               |      |          |
|  |   | CD4097 on Any   |   |                                   |                                   |                                   |           | 18               |      |          |

### 5.5 Electrical Characteristics (续)

Over operating free-air temperature range,  $V_{SUPPLY} = \pm 5V$ , and  $R_L = 100\Omega$ , (unless otherwise noted)<sup>(1)</sup>

| PARAMETER                                  | TEST CONDITIONS   | TEST CONDITIONS | TEST CONDITIONS | TEST CONDITIONS | MIN | TYP | MAX | UNIT |
|--|---|-----------------|-----------------|-----------------|-----|-----|-----|------|
| Crosstalk (control input to signal output) | $V_C = 10V$ (square wave), $R_L = 10k\Omega$ , $V_{DD} = 10V$ |                 |                 |                 |     | 75  |     | mV   |

- (1) Peak-to-Peak voltage symmetrical about  $(V_{DD} - V_{EE}) / 2$ .
- (2) Determined by minimum feasible leakage measurement for automatic testing.

### 5.6 AC Performance Characteristics

$V_{DD} = +15V$ ,  $V_{SS} = V_{EE} = 0V$ ,

$T_A = 25^\circ C$  (unless otherwise noted)

| PARAMETER | FROM         | TO            | TEST CONDITIONS                                     | $V_{CC}$ | MIN | TYP | MAX | UNIT |
|-----------|--------------|---------------|---|----------|-----|-----|-----|------|
| $t_{pd}$  | Signal Input | Signal Output | $V_{IN} = V_{DD}$ , $C_L = 50$ pF, $R_L = 1k\Omega$ | 5V       |     | 30  | 60  | ns   |
|           |              |               |   | 10V      |     | 15  | 30  |      |
|           |              |               |   | 15V      |     | 7   | 20  |      |
| $t_{ph}$  | Signal Input | Signal Output | $V_{IN} = V_{DD}$ , $C_L = 50$ pF, $R_L = 1k\Omega$ | 5V       |     | 325 | 650 | ns   |
|           |              |               |   | 10V      |     | 135 | 270 |      |
|           |              |               |   | 15V      |     | 95  | 190 |      |
| $t_{phi}$ | Signal Input | Signal Output | $V_{IN} = V_{DD}$ , $C_L = 50$ pF, $R_L = 1k\Omega$ | 5V       |     | 220 | 440 | ns   |
|           |              |               |   | 10V      |     | 90  | 180 |      |
|           |              |               |   | 15V      |     | 65  | 130 |      |

### 5.7 Typical Characteristics



图 5-1. System Settling Time vs Signal Rise/Fall Time



图 5-2. System Settling Time vs Signal Voltage

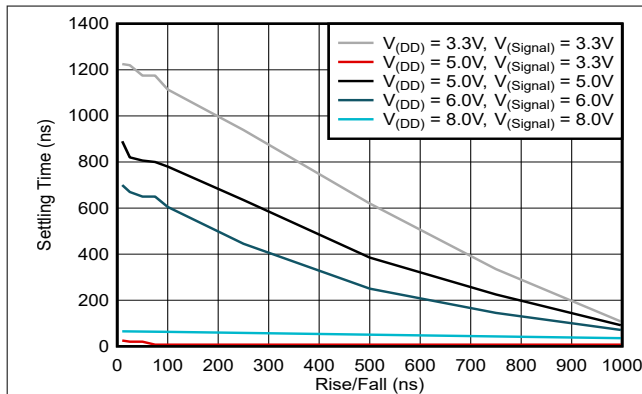

图 5-3. System Settling Time vs Signal Voltage

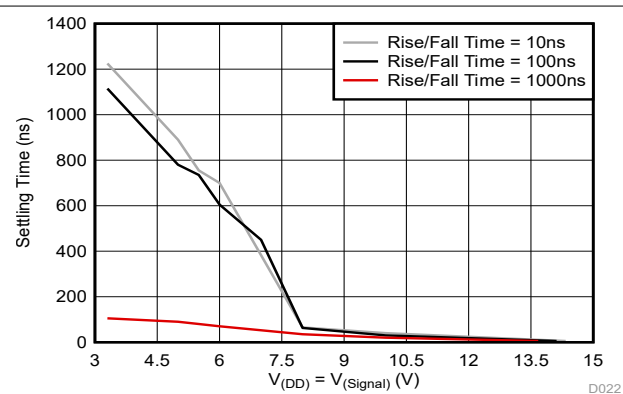

图 5-4. Source Voltage Input vs Drain Voltage Output

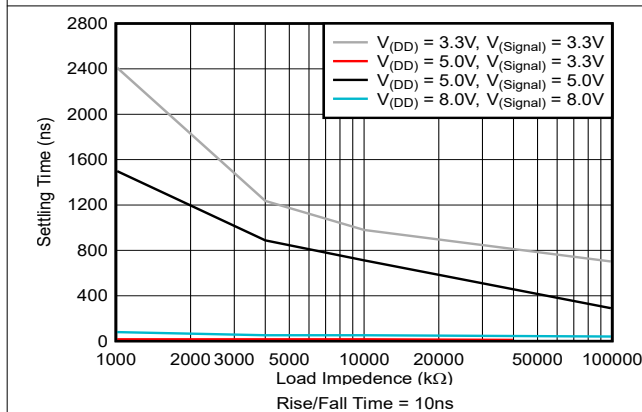

## 6 Parameter Measurement Information

### 6.1 Test Circuits

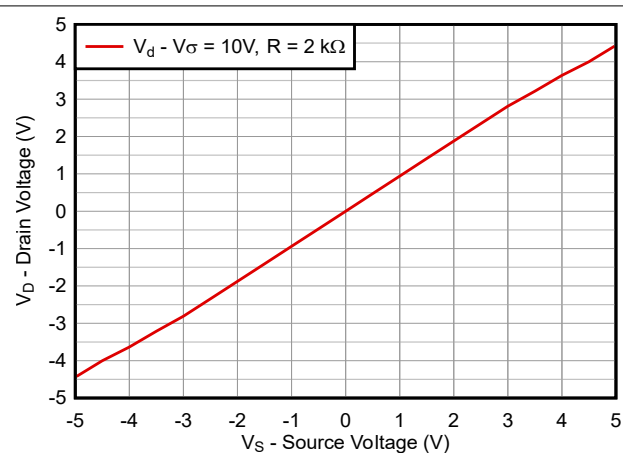

图 6-1. OFF Channel Leakage Current – Any Channel OFF



图 6-2. Input Voltage – Measure  $<2\mu\text{A}$  on all OFF Channels (For Example, Channel 12)

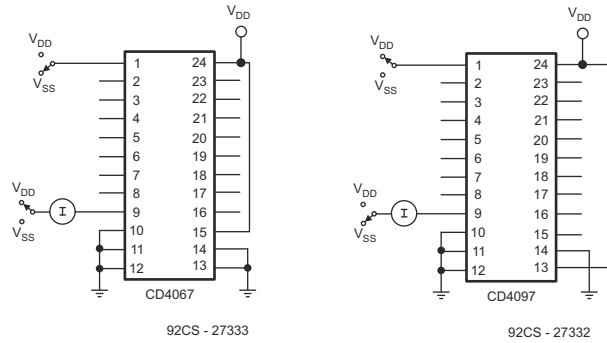

图 6-3. OFF Channel Leakage Current – All Channels OFF

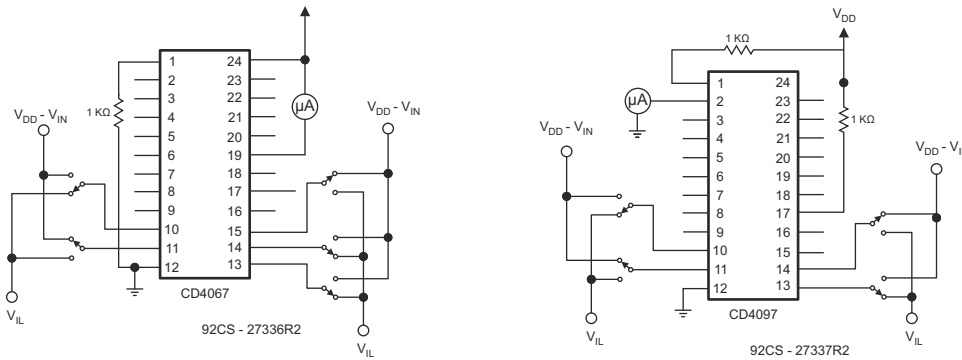

图 6-4. Quiescent Device Current

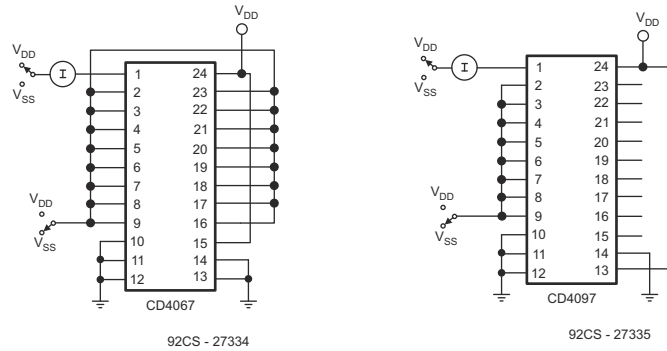

图 6-5. Turn-on and Turn-off Propagation Delay – Address Select Input to Signal Output (For Example,, Measured on Channel 0)

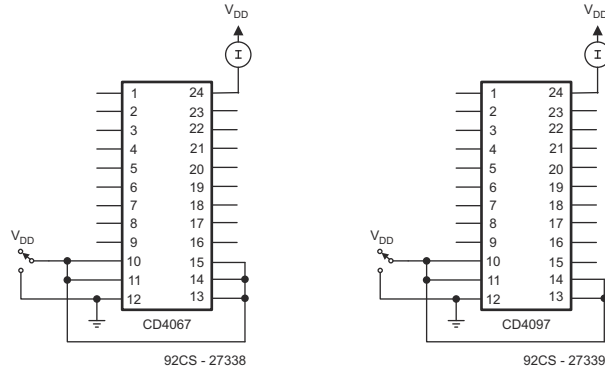

图 6-6. Turn-on and Turn-off Propagation Delay – Inhibit Input to Signal Output (For Example,, Measured on Channel 1)

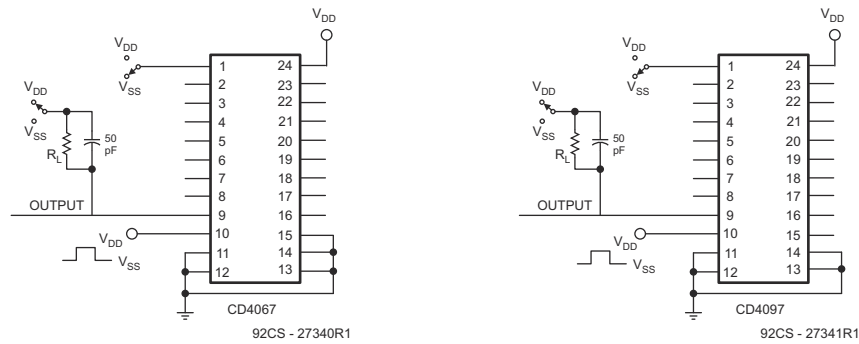

图 6-7. Channel ON Resistance Measurement Circuit

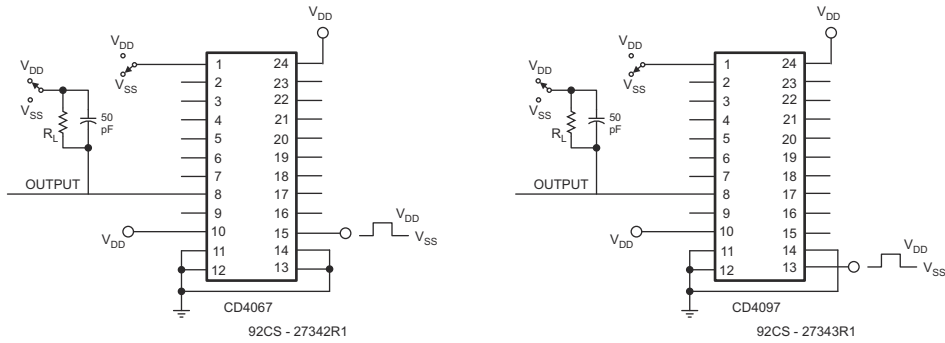

图 6-8. Propagation Delay Waveform Channel Being turned ON ( $R_L = 10k\Omega$ ,  $C_L = 50$  pF)

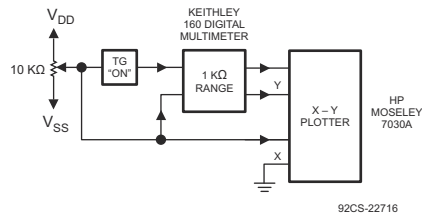

图 6-9. Propagation Delay Waveform Channel Being turned OFF ( $R_L = 300\Omega$ ,  $C_L = 50$  pF)

## 7 Detailed Description

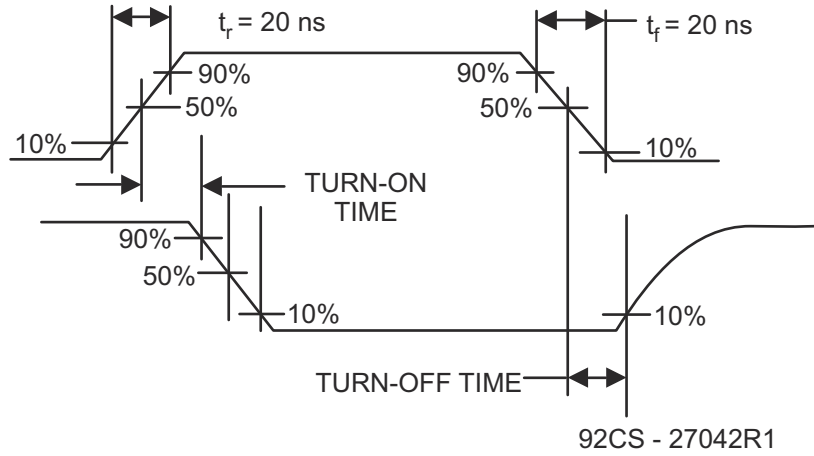
### 7.1 Functional Block Diagram

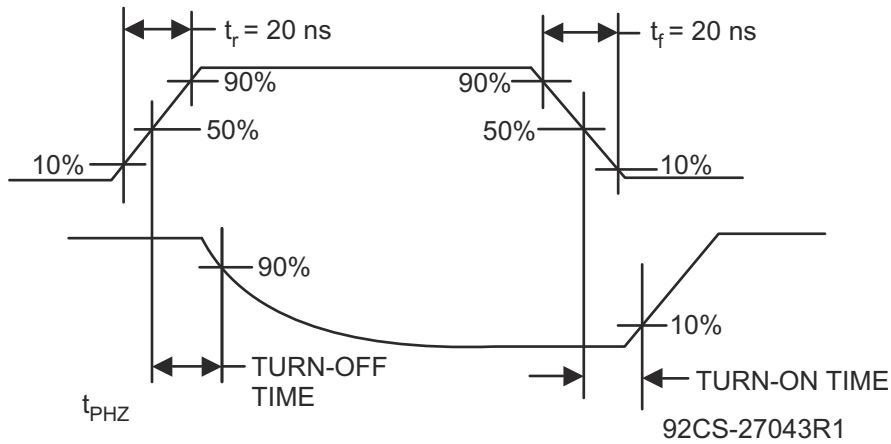

图 7-1. CD4067



图 7-2. CD4097

### 7.2 Device Functional Modes

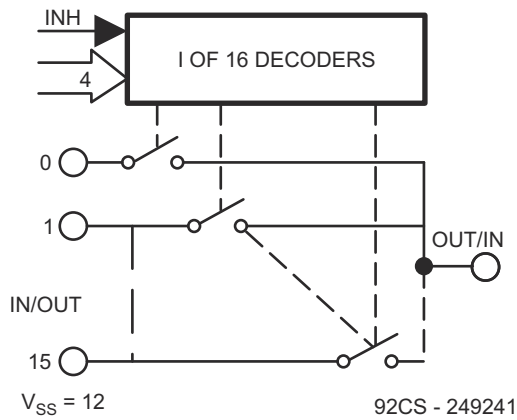
表 7-1. Function Table

| CD4067 TRUTH TABLE |   |   |   |     |                  |
|--------------------|---|---|---|-----|------------------|
| A                  | B | C | D | inh | Selected Channel |
| X                  | X | X | X | 1   | None             |
| 0                  | 0 | 0 | 0 | 0   | 0                |
| 1                  | 0 | 0 | 0 | 0   | 1                |
| 0                  | 1 | 0 | 0 | 0   | 2                |
| 1                  | 1 | 0 | 0 | 0   | 3                |
| 0                  | 0 | 1 | 0 | 0   | 4                |
| 1                  | 0 | 1 | 0 | 0   | 5                |
| 0                  | 1 | 1 | 0 | 0   | 6                |
| 1                  | 1 | 1 | 0 | 0   | 7                |
| 0                  | 0 | 0 | 1 | 0   | 8                |
| 1                  | 0 | 0 | 1 | 0   | 9                |
| 0                  | 1 | 0 | 1 | 0   | 10               |
| 1                  | 1 | 0 | 1 | 0   | 11               |
| 0                  | 0 | 1 | 1 | 0   | 12               |
| 1                  | 0 | 1 | 1 | 0   | 13               |
| 0                  | 1 | 1 | 1 | 0   | 14               |
| 1                  | 1 | 1 | 1 | 0   | 15               |

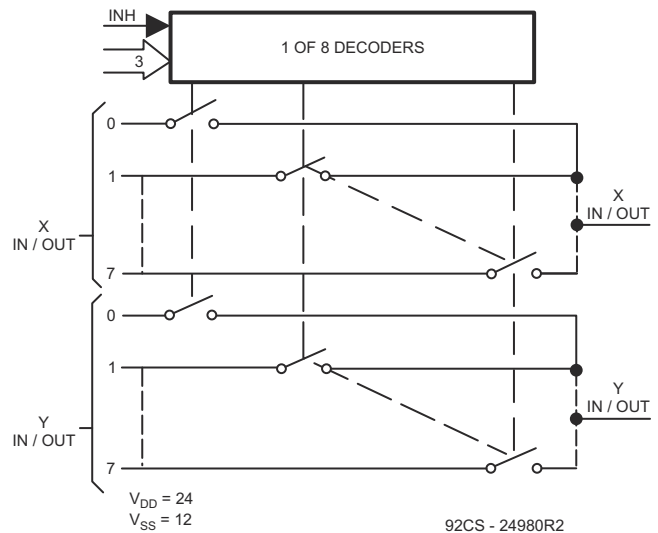
**表 7-2. Function Table**

| CD4097 TRUTH TABLE |   |   |     |                  |
|--------------------|---|---|-----|------------------|
| A                  | B | C | inh | Selected Channel |
| X                  | X | X | 1   | None             |
| 0                  | 0 | 0 | 0   | 0X, 0Y           |
| 1                  | 0 | 0 | 0   | 1X, 1Y           |
| 0                  | 1 | 0 | 0   | 2X, 2Y           |
| 1                  | 1 | 0 | 0   | 3X, 3Y           |
| 0                  | 0 | 1 | 0   | 4X, 4Y           |
| 1                  | 0 | 1 | 0   | 5X, 5Y           |
| 0                  | 1 | 1 | 0   | 6X, 6Y           |
| 1                  | 1 | 1 | 0   | 7X, 7Y           |

## 8 Application and Implementation

### 备注

以下应用部分中的信息不属于 TI 元件规格，TI 不担保其准确性和完整性。TI 的客户负责确定元件是否适合其用途，以及验证和测试其设计实现以确认系统功能。

### 8.1 Application Information

#### 8.1.1 Special Considerations

In applications where separate power sources are used to drive  $V_{DD}$  and the signal inputs, the  $V_{DD}$  current capability should exceed  $V_{DD}/R_L$  ( $R_L$  = effective external load). This provision avoids permanent current flow or clamp action on the  $V_{DD}$  supply when power is applied or removed from the CD40x7B.

When switching from one address to another, some of the ON periods of the channels of the multiplexers will overlap momentarily, which may be objectionable in certain applications. Also, when a channel is turned on or off by an address input, there is a momentary conductive path from the channel to  $V_{SS}$ , which will dump some charge from any capacitor connected to the input or output of the channel. The inhibit input turning on a channel will similarly dump some charge to  $V_{SS}$ .

The amount of charge dumped is mostly a function of the signal level above  $V_{SS}$ . Typically, at  $V_{DD}-V_{SS} = 10V$ , a 100pF capacitor connected to the input or output of the channel will lose 3-4% of its voltage at the moment the channel turns on or off. This loss of voltage is essentially independent of the address or inhibit signal transition time, if the transition time is less than 1-2 $\mu$ s. When the inhibit signal turns a channel off, there is no charge dumping to  $V_{SS}$ . Rather, there is a slight rise in the channel voltage level (65mV typical) due to capacitive coupling from inhibit input to channel input or output. Address inputs also couple some voltage steps onto the channel signal levels.

In certain applications, the external load-resistor current may include both  $V_{DD}$  and signal-line components. To avoid drawing  $V_{DD}$  current when switch current flows into the transmission gate inputs, the voltage drop across the bidirectional switch must not exceed 0.8V (calculated from  $R_{TON}$  values shown in *Electrical Characteristics* tables). No  $V_{DD}$  current will flow through  $R_L$  if the switch current flows into terminal 1 on the CD4067B, terminals 1 and 17 on the CD4097B.

### 8.2 Typical Application



图 8-1. 18-24-to-1 MUX Addressing

## 9 Device and Documentation Support

### 9.1 接收文档更新通知

要接收文档更新通知，请导航至 [ti.com](https://ti.com) 上的器件产品文件夹。点击 [通知](#) 进行注册，即可每周接收产品信息更改摘要。有关更改的详细信息，请查看任何已修订文档中包含的修订历史记录。

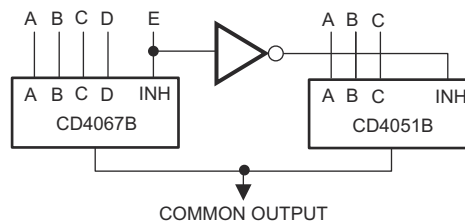
### 9.2 支持资源

[TI E2E™ 中文支持论坛](#) 是工程师的重要参考资料，可直接从专家处获得快速、经过验证的解答和设计帮助。搜索现有解答或提出自己的问题，获得所需的快速设计帮助。

链接的内容由各个贡献者“按原样”提供。这些内容并不构成 TI 技术规范，并且不一定反映 TI 的观点；请参阅 TI 的 [使用条款](#)。

### 9.3 Trademarks

TI E2E™ is a trademark of Texas Instruments.  
所有商标均为其各自所有者的财产。

### 9.4 静电放电警告



静电放电 (ESD) 会损坏这个集成电路。德州仪器 (TI) 建议通过适当的预防措施处理所有集成电路。如果不遵守正确的处理和安装程序，可能会损坏集成电路。

ESD 的损坏小至导致微小的性能降级，大至整个器件故障。精密的集成电路可能更容易受到损坏，这是因为非常细微的参数更改都可能会导致器件与其发布的规格不相符。

### 9.5 术语表

[TI 术语表](#) 本术语表列出并解释了术语、首字母缩略词和定义。

## 10 Revision History

注：以前版本的页码可能与当前版本的页码不同

| Changes from Revision C (July 2024) to Revision D (August 2024) | Page |
|---|------|
| • Added Settling Time plots.....                                | 8    |

| Changes from Revision B (June 2003) to Revision C (July 2024) | Page |
|---|------|
| • 通篇更新了表格、图和交叉参考的编号格式.....                                    | 1    |
| • Changed max and typ IDD for lower supply voltages.....      | 6    |
| • Changed max IIN at low temperature.....                     | 6    |

## 11 Mechanical, Packaging, and Orderable Information

The following pages include mechanical, packaging, and orderable information. This information is the most current data available for the designated devices. This data is subject to change without notice and revision of this document. For browser-based versions of this data sheet, refer to the left-hand navigation.

**PACKAGING INFORMATION**

| Orderable Device | Status<br>(1) | Package Type | Package Drawing | Pins | Package Qty | Eco Plan<br>(2)      | Lead finish/<br>Ball material<br>(6) | MSL Peak Temp<br>(3) | Op Temp (°C) | Device Marking<br>(4/5) | Samples                 |
|------------------|---------------|--------------|-----------------|------|-------------|----------------------|--------------------------------------|----------------------|--------------|-------------------------|-------------------------|
| CD4067BF         | ACTIVE        | CDIP         | J               | 24   | 15          | Non-RoHS & Non-Green | Call TI                              | N / A for Pkg Type   | -55 to 125   | CD4067BF                | <a href="#">Samples</a> |
| CD4067BF3A       | ACTIVE        | CDIP         | J               | 24   | 15          | Non-RoHS & Non-Green | Call TI                              | N / A for Pkg Type   | -55 to 125   | CD4067BF3A              | <a href="#">Samples</a> |
| CD4067BM         | OBSOLETE      | SOIC         | DW              | 24   |             | TBD                  | Call TI                              | Call TI              | -55 to 125   | CD4067BM                |                         |
| CD4067BM96       | ACTIVE        | SOIC         | DW              | 24   | 2000        | RoHS & Green         | NIPDAU                               | Level-1-260C-UNLIM   | -55 to 125   | CD4067BM                | <a href="#">Samples</a> |
| CD4067BM96G4     | OBSOLETE      | SOIC         | DW              | 24   |             | TBD                  | Call TI                              | Call TI              | -55 to 125   | CD4067BM                |                         |
| CD4067BPW        | OBSOLETE      | TSSOP        | PW              | 24   |             | TBD                  | Call TI                              | Call TI              | -55 to 125   | CM067B                  |                         |
| CD4067BPWR       | ACTIVE        | TSSOP        | PW              | 24   | 2000        | RoHS & Green         | NIPDAU                               | Level-1-260C-UNLIM   | -55 to 125   | CM067B                  | <a href="#">Samples</a> |
| CD4097BF         | ACTIVE        | CDIP         | J               | 24   | 15          | Non-RoHS & Non-Green | Call TI                              | N / A for Pkg Type   | -55 to 125   | CD4097BF                | <a href="#">Samples</a> |
| CD4097BM         | NRND          | SOIC         | DW              | 24   | 25          | RoHS & Green         | NIPDAU                               | Level-1-260C-UNLIM   | -55 to 125   | CD4097BM                |                         |
| CD4097BME4       | NRND          | SOIC         | DW              | 24   | 25          | RoHS & Green         | NIPDAU                               | Level-1-260C-UNLIM   | -55 to 125   | CD4097BM                |                         |
| CD4097BMG4       | NRND          | SOIC         | DW              | 24   | 25          | RoHS & Green         | NIPDAU                               | Level-1-260C-UNLIM   | -55 to 125   | CD4097BM                |                         |
| CD4097BPW        | NRND          | TSSOP        | PW              | 24   | 60          | RoHS & Green         | NIPDAU                               | Level-1-260C-UNLIM   | -55 to 125   | CM097B                  |                         |
| CD4097BPWR       | NRND          | TSSOP        | PW              | 24   | 2000        | RoHS & Green         | NIPDAU                               | Level-1-260C-UNLIM   | -55 to 125   | CM097B                  |                         |
| CD4097BPWRE4     | NRND          | TSSOP        | PW              | 24   | 2000        | RoHS & Green         | NIPDAU                               | Level-1-260C-UNLIM   | -55 to 125   | CM097B                  |                         |

(1) The marketing status values are defined as follows:

**ACTIVE:** Product device recommended for new designs.

**LIFEBUY:** TI has announced that the device will be discontinued, and a lifetime-buy period is in effect.

**NRND:** Not recommended for new designs. Device is in production to support existing customers, but TI does not recommend using this part in a new design.

**PREVIEW:** Device has been announced but is not in production. Samples may or may not be available.

**OBSOLETE:** TI has discontinued the production of the device.

(2) **RoHS:** TI defines "RoHS" to mean semiconductor products that are compliant with the current EU RoHS requirements for all 10 RoHS substances, including the requirement that RoHS substance do not exceed 0.1% by weight in homogeneous materials. Where designed to be soldered at high temperatures, "RoHS" products are suitable for use in specified lead-free processes. TI may reference these types of products as "Pb-Free".

**RoHS Exempt:** TI defines "RoHS Exempt" to mean products that contain lead but are compliant with EU RoHS pursuant to a specific EU RoHS exemption.

**Green:** TI defines "Green" to mean the content of Chlorine (Cl) and Bromine (Br) based flame retardants meet JS709B low halogen requirements of <=1000ppm threshold. Antimony trioxide based flame retardants must also meet the <=1000ppm threshold requirement.



- (3) MSL, Peak Temp. - The Moisture Sensitivity Level rating according to the JEDEC industry standard classifications, and peak solder temperature.
- (4) There may be additional marking, which relates to the logo, the lot trace code information, or the environmental category on the device.
- (5) Multiple Device Markings will be inside parentheses. Only one Device Marking contained in parentheses and separated by a "~" will appear on a device. If a line is indented then it is a continuation of the previous line and the two combined represent the entire Device Marking for that device.
- (6) Lead finish/Ball material - Orderable Devices may have multiple material finish options. Finish options are separated by a vertical ruled line. Lead finish/Ball material values may wrap to two lines if the finish value exceeds the maximum column width.

**Important Information and Disclaimer:**The information provided on this page represents TI's knowledge and belief as of the date that it is provided. TI bases its knowledge and belief on information provided by third parties, and makes no representation or warranty as to the accuracy of such information. Efforts are underway to better integrate information from third parties. TI has taken and continues to take reasonable steps to provide representative and accurate information but may not have conducted destructive testing or chemical analysis on incoming materials and chemicals. TI and TI suppliers consider certain information to be proprietary, and thus CAS numbers and other limited information may not be available for release.

In no event shall TI's liability arising out of such information exceed the total purchase price of the TI part(s) at issue in this document sold by TI to Customer on an annual basis.

**OTHER QUALIFIED VERSIONS OF CD4067B, CD4067B-MIL, CD4097B, CD4097B-MIL :**

- Catalog : [CD4067B](#), [CD4097B](#)
- Military : [CD4067B-MIL](#), [CD4097B-MIL](#)

NOTE: Qualified Version Definitions:

- Catalog - TI's standard catalog product
- Military - QML certified for Military and Defense Applications

**TAPE AND REEL INFORMATION**

**QUADRANT ASSIGNMENTS FOR PIN 1 ORIENTATION IN TAPE**

\*All dimensions are nominal

| Device     | Package Type | Package Drawing | Pins | SPQ  | Reel Diameter (mm) | Reel Width W1 (mm) | A0 (mm) | B0 (mm) | K0 (mm) | P1 (mm) | W (mm) | Pin1 Quadrant |
|------------|--------------|-----------------|------|------|--------------------|--------------------|---------|---------|---------|---------|--------|---------------|
| CD4067BM96 | SOIC         | DW              | 24   | 2000 | 330.0              | 24.4               | 10.75   | 15.7    | 2.7     | 12.0    | 24.0   | Q1            |
| CD4067BPWR | TSSOP        | PW              | 24   | 2000 | 330.0              | 16.4               | 6.95    | 8.3     | 1.6     | 8.0     | 16.0   | Q1            |
| CD4067BPWR | TSSOP        | PW              | 24   | 2000 | 330.0              | 16.4               | 6.95    | 8.3     | 1.6     | 8.0     | 16.0   | Q1            |
| CD4097BPWR | TSSOP        | PW              | 24   | 2000 | 330.0              | 16.4               | 6.95    | 8.3     | 1.6     | 8.0     | 16.0   | Q1            |

## TAPE AND REEL BOX DIMENSIONS



\*All dimensions are nominal

| Device     | Package Type | Package Drawing | Pins | SPQ  | Length (mm) | Width (mm) | Height (mm) |
|------------|--------------|-----------------|------|------|-------------|------------|-------------|
| CD4067BM96 | SOIC         | DW              | 24   | 2000 | 350.0       | 350.0      | 43.0        |
| CD4067BPWR | TSSOP        | PW              | 24   | 2000 | 353.0       | 353.0      | 32.0        |
| CD4067BPWR | TSSOP        | PW              | 24   | 2000 | 356.0       | 356.0      | 35.0        |
| CD4097BPWR | TSSOP        | PW              | 24   | 2000 | 356.0       | 356.0      | 35.0        |

**TUBE**

\*All dimensions are nominal

| Device     | Package Name | Package Type | Pins | SPQ | L (mm) | W (mm) | T (μm) | B (mm) |
|------------|--------------|--------------|------|-----|--------|--------|--------|--------|
| CD4097BM   | DW           | SOIC         | 24   | 25  | 506.98 | 12.7   | 4826   | 6.6    |
| CD4097BME4 | DW           | SOIC         | 24   | 25  | 506.98 | 12.7   | 4826   | 6.6    |
| CD4097BMG4 | DW           | SOIC         | 24   | 25  | 506.98 | 12.7   | 4826   | 6.6    |
| CD4097BPW  | PW           | TSSOP        | 24   | 60  | 530    | 10.2   | 3600   | 3.5    |

DW (R-PDSO-G24)

PLASTIC SMALL OUTLINE



- NOTES:
- A. All linear dimensions are in inches (millimeters). Dimensioning and tolerancing per ASME Y14.5M-1994.
  - B. This drawing is subject to change without notice.
  - C. Body dimensions do not include mold flash or protrusion not to exceed 0.006 (0,15).
  - D. Falls within JEDEC MS-013 variation AD.

J (R-GDIP-T\*\*)

CERAMIC DUAL-IN-LINE PACKAGE

24 PINS SHOWN

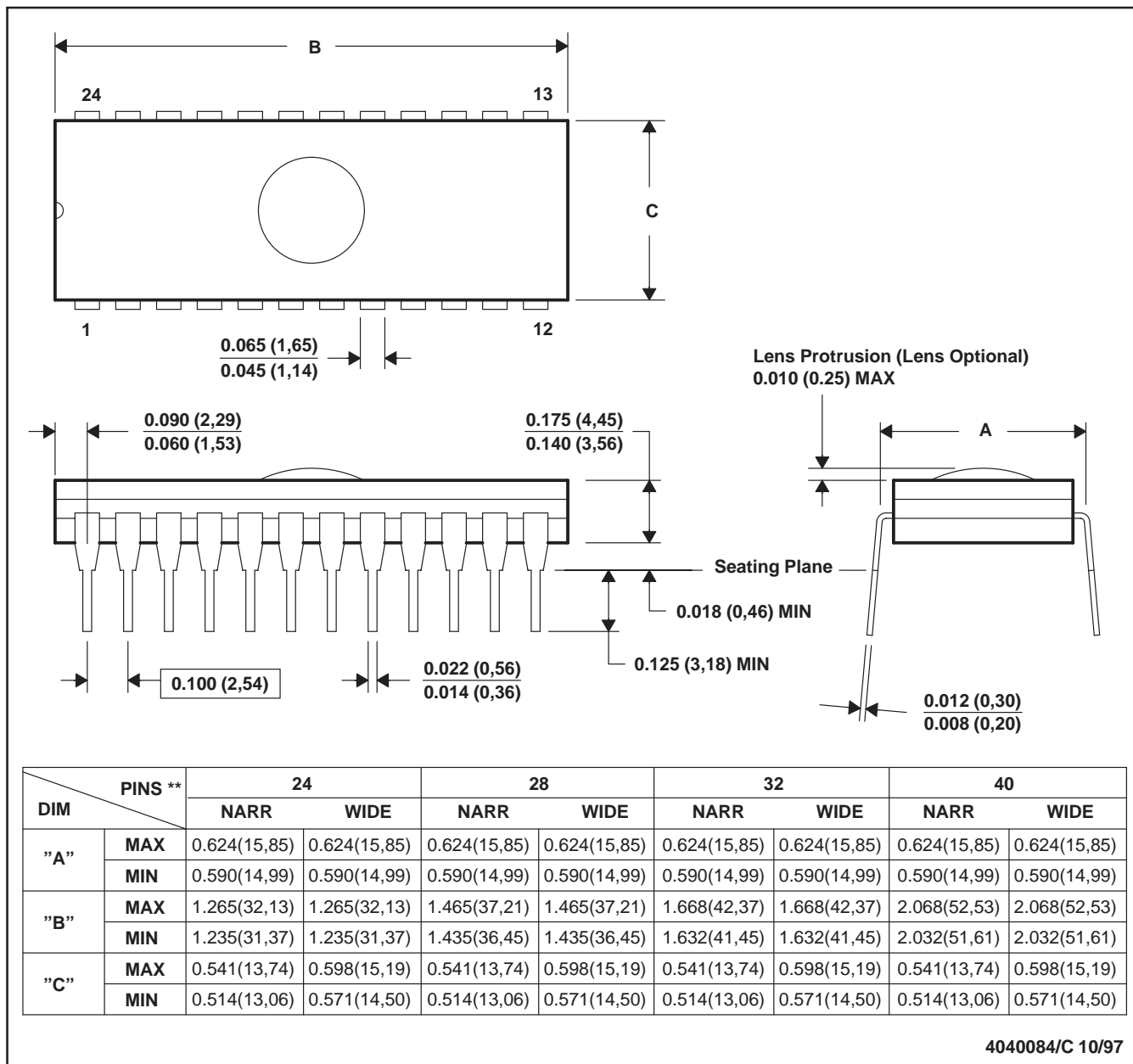

- NOTES: A. All linear dimensions are in inches (millimeters).  
 B. This drawing is subject to change without notice.  
 C. Window (lens) added to this group of packages (24-, 28-, 32-, 40-pin).  
 D. This package can be hermetically sealed with a ceramic lid using glass frit.  
 E. Index point is provided on cap for terminal identification.

PW0024A



# PACKAGE OUTLINE

## TSSOP - 1.2 mm max height

SMALL OUTLINE PACKAGE



4220208/A 02/2017

NOTES:

- All linear dimensions are in millimeters. Any dimensions in parenthesis are for reference only. Dimensioning and tolerancing per ASME Y14.5M.
- This drawing is subject to change without notice.
- This dimension does not include mold flash, protrusions, or gate burrs. Mold flash, protrusions, or gate burrs shall not exceed 0.15 mm per side.
- This dimension does not include interlead flash. Interlead flash shall not exceed 0.25 mm per side.
- Reference JEDEC registration MO-153.

# EXAMPLE BOARD LAYOUT

PW0024A

TSSOP - 1.2 mm max height

SMALL OUTLINE PACKAGE



LAND PATTERN EXAMPLE  
EXPOSED METAL SHOWN  
SCALE: 10X



SOLDER MASK DETAILS

4220208/A 02/2017

NOTES: (continued)

- 6. Publication IPC-7351 may have alternate designs.
- 7. Solder mask tolerances between and around signal pads can vary based on board fabrication site.



# EXAMPLE STENCIL DESIGN

PW0024A

TSSOP - 1.2 mm max height

SMALL OUTLINE PACKAGE



NOTES: (continued)

8. Laser cutting apertures with trapezoidal walls and rounded corners may offer better paste release. IPC-7525 may have alternate design recommendations.
9. Board assembly site may have different recommendations for stencil design.

## 重要通知和免责声明

TI“按原样”提供技术和可靠性数据（包括数据表）、设计资源（包括参考设计）、应用或其他设计建议、网络工具、安全信息和其他资源，不保证没有瑕疵且不做任何明示或暗示的担保，包括但不限于对适销性、某特定用途方面的适用性或不侵犯任何第三方知识产权的暗示担保。

这些资源可供使用 TI 产品进行设计的熟练开发人员使用。您将自行承担以下全部责任：(1) 针对您的应用选择合适的 TI 产品，(2) 设计、验证并测试您的应用，(3) 确保您的应用满足相应标准以及任何其他功能安全、信息安全、监管或其他要求。

这些资源如有变更，恕不另行通知。TI 授权您仅可将这些资源用于研发本资源所述的 TI 产品的相关应用。严禁以其他方式对这些资源进行复制或展示。您无权使用任何其他 TI 知识产权或任何第三方知识产权。您应全额赔偿因在这些资源的使用中对 TI 及其代表造成的任何索赔、损害、成本、损失和债务，TI 对此概不负责。

TI 提供的产品受 [TI 的销售条款](#) 或 [ti.com](#) 上其他适用条款/TI 产品随附的其他适用条款的约束。TI 提供这些资源并不会扩展或以其他方式更改 TI 针对 TI 产品发布的适用的担保或担保免责声明。

TI 反对并拒绝您可能提出的任何其他或不同的条款。

邮寄地址：Texas Instruments, Post Office Box 655303, Dallas, Texas 75265  
版权所有 © 2025，德州仪器 (TI) 公司