

CD74AC151 8:1 数据选择器/多路复用器

1 特性

- 交流类型的工作电压范围为 1.5V 至 5.5V，并在电源电压的 30% 时具有平衡的抗噪性能
- 8:1 线多路复用器可作为以下器件运行：
 - 布尔函数发生器
 - 并行转串行转换器
 - 数据选择器
- 双极 F、AS 和 S 的速度，同时显著降低功耗并平衡传播延迟
- ±24mA 输出驱动电流
 - 扇出至 15 个 F 器件
- 防 SCR 闩锁 CMOS 工艺和电路设计
- ESD 保护超过 2kV (根据 MIL-STD-883 方法 3015)

2 说明

该数据选择器/多路复用器支持完整二进制解码，可从八个数据源中选择其中一个。选通 (\overline{G}) 输入必须设为逻辑低电平，才能启用输入。将选通端子设为高电平，会强制 W 输出端输出高电平，Y 输出端输出低电平。

封装信息

器件型号	封装 ⁽¹⁾	封装尺寸 ⁽²⁾	本体尺寸 ⁽³⁾
CD74AC151	D (SOIC, 16)	9.90mm × 6mm	9.90mm × 3.90mm
	N (PDIP, 16)	19.3mm × 9.4mm	19.3mm × 6.35mm

- 如需了解更多信息，请参阅机械、封装和可订购信息。
- 封装尺寸 (长 × 宽) 为标称值，并包括引脚 (如适用)。
- 本体尺寸 (长 × 宽) 为标称值，不包括引脚。

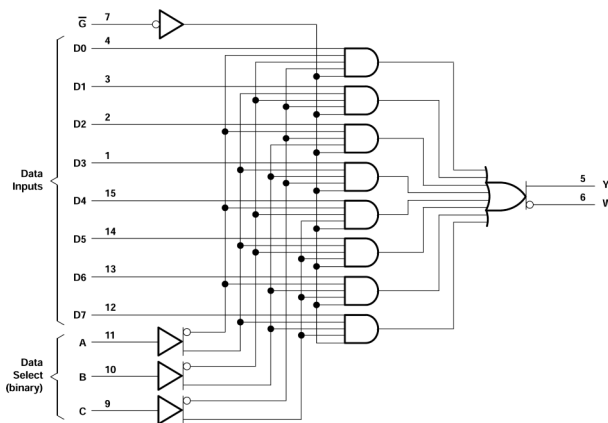

逻辑图 (正逻辑)



Table of Contents

1 特性	1	6.1 Functional Block Diagram.....	9
2 说明	1	6.2 Device Functional Modes.....	9
3 Pin Configuration and Functions	3	7 Application and Implementation	10
4 Specifications	4	7.1 Power Supply Recommendations.....	10
4.1 Absolute Maximum Ratings.....	4	7.2 Layout.....	10
4.2 ESD Ratings.....	4	8 Device and Documentation Support	11
4.3 Recommended Operating Conditions.....	4	8.1 Documentation Support (Analog).....	11
4.4 Thermal Information.....	5	8.2 接收文档更新通知.....	11
4.5 Electrical Characteristics.....	5	8.3 支持资源.....	11
4.6 Switching Characteristics, $V_{CC} = 1.5V$	5	8.4 Trademarks.....	11
4.7 Switching Characteristics, $V_{CC} = 3.3V \pm 0.3V$	6	8.5 静电放电警告.....	11
4.8 Switching Characteristics, $V_{CC} = 5V \pm 0.5V$	6	8.6 术语表.....	11
4.9 Operating Characteristics.....	6	9 Revision History	11
5 Parameter Measurement Information	7	10 Mechanical, Packaging, and Orderable Information	12
6 Detailed Description	9		

3 Pin Configuration and Functions



图 3-1. D or N Packages; 16-Pin SOIC or PDIP (Top View)

Pin Functions

PIN		I/O ⁽¹⁾	DESCRIPTION
NO.	NAME		
1	D3	I	Data input 3
2	D2	I	Data input 2
3	D1	I	Data input 1
4	D0	I	Data input 0
5	Y	O	Data output
6	W	O	Data output, inverted
7	\overline{G}	I	Output strobe, active low
8	GND	—	Ground
9	C	I	Address select C
10	B	I	Address select B
11	A	I	Address select A
12	D7	I	Data input 7
13	D6	I	Data input 6
14	D5	I	Data input 5
15	D4	I	Data input 4
16	V _{CC}	—	Positive supply

(1) I = input, O = output, P = power, FB = feedback, GND = ground, N/A = not applicable

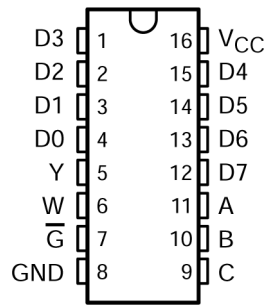
4 Specifications

4.1 Absolute Maximum Ratings

over operating free-air temperature range (unless otherwise noted)⁽¹⁾

		MIN	MAX	UNIT
V _{CC}	Supply voltage range	- 0.5	6	V
I _{IK} ⁽²⁾	Input clamp current	(V _I < 0 or V _I > V _{CC})		±20 mA
I _{OK} ⁽²⁾	Output clamp current	(V _O < 0 or V _O > V _{CC})		±50 mA
I _O	Continuous output current	(V _O = 0 to V _{CC})		±50 mA
Continuous current through V _{CC} or GND				±100 mA
T _{stg}	Storage temperature range	- 65	150	°C

- (1) Stresses beyond those listed under “absolute maximum ratings” may cause permanent damage to the device. These are stress ratings only, and functional operation of the device at these or any other conditions beyond those indicated under “recommended operating conditions” is not implied. Exposure to absolute-maximum-rated conditions for extended periods may affect device reliability.
- (2) The input and output voltage ratings may be exceeded if the input and output current ratings are observed.

4.2 ESD Ratings

			VALUE	UNIT
V _(ESD)	Electrostatic discharge	Human body model (HBM), per AEC Q100-002 ⁽¹⁾	±2000	V

- (1) JEDEC document JEP155 states that 500V HBM allows safe manufacturing with a standard ESD control process.

4.3 Recommended Operating Conditions

over operating free-air temperature range (unless otherwise noted)⁽¹⁾

		T _A = 25°C		-55°C to 125°C		-40°C to 85°C		UNIT
		MIN	MAX	MIN	MAX	MIN	MAX	
V _{CC}	Supply voltage	1.5	5.5	1.5	5.5	1.5	5.5	V
V _{IH}	High-level input voltage	V _{CC} = 1.5 V		1.2		1.2		V
		V _{CC} = 3 V		2.1		2.1		
		V _{CC} = 5.5 V		3.85		3.85		
V _{IL}	Low-level input voltage	V _{CC} = 1.5 V			0.3		0.3	V
		V _{CC} = 3 V			0.9		0.9	
		V _{CC} = 5.5 V			1.65		1.65	
V _I	Input voltage	0	V _{CC}	0	V _{CC}	0	V _{CC}	V
V _O	Output voltage	0	V _{CC}	0	V _{CC}	0	V _{CC}	V
I _{OH}	High-level output current	V _{CC} = 4.5 V to 5.5 V			-24		-24	mA
I _{OL}	Low-level output current	V _{CC} = 4.5 V to 5.5 V			24		24	mA
Δt/ Δv	Input transition rise or fall rate	V _{CC} = 1.5 V to 3 V			50		50	ns/V
		V _{CC} = 3.6 V to 5.5 V			20		20	

- (1) All unused inputs of the device must be held at V_{CC} or GND to ensure proper device operation. Refer to the TI application report, *Implications of Slow or Floating CMOS Inputs*, literature number SCBA004.

4.4 Thermal Information

THERMAL METRIC		D (SOIC)	N (PDIP)	UNIT
		16 PINS	16 PINS	
$R_{\theta JA}$	Junction-to-ambient thermal resistance ⁽¹⁾	119.9	67	°C/W

(1) For more information about traditional and new thermal metrics, see the [Semiconductor and IC package thermal metrics](#) application report.

4.5 Electrical Characteristics

over recommended operating free-air temperature range (unless otherwise noted)

PARAMETER	TEST CONDITIONS		V_{CC}	TA = 25°C		-55°C to 125°C		-40°C to 85°C		UNIT
				MIN	MAX	MIN	MAX	MIN	MAX	
V_{OH}	$V_I = V_{IH}$ or V_{IL}	$I_{OH} = -50 \mu A$	1.5 V	1.4	1.4	1.4	1.4	V		
			3 V	2.9	2.9	2.9				
			4.5 V	4.4	4.4	4.4				
		$I_{OH} = -4 mA$	3 V	2.58	2.4	2.48				
		$I_{OH} = -24 mA$	4.5 V	3.94	3.7	3.8				
		$I_{OH} = -50 mA^{(1)}$	5.5 V		3.85					
		$I_{OH} = -75 mA^{(1)}$	5.5 V			3.85				
V_{OL}	$V_I = V_{IH}$ or V_{IL}	$I_{OL} = 50 \mu A$	1.5 V	0.1	0.1	0.1	V			
			3 V	0.1	0.1	0.1				
			4.5 V	0.1	0.1	0.1				
		$I_{OL} = 12 mA$	3 V	0.36	0.5	0.44				
		$I_{OL} = 24 mA$	4.5 V	0.36	0.5	0.44				
		$I_{OL} = 50 mA^{(1)}$	5.5 V		1.65	-				
		$I_{OL} = 75 mA^{(1)}$	5.5 V			1.65				
I_I	$V_I = V_{CC}$ or GND		5.5 V	±0.1	±1	±1	μA			
I_{CC}	$V_I = V_{CC}$ or GND,	$I_O = 0$	5.5 V	8	160	80	μA			
C_i				10	10	10	pF			

(1) Test one output at a time, not exceeding 1-second duration. Measurement is made by forcing indicated current and measuring voltage to minimize power dissipation. Test verifies a minimum 50-Ω transmission-line drive capability at 85°C and 75-Ω transmission-line drive capability at 125°C.

4.6 Switching Characteristics, $V_{CC} = 1.5V$

over recommended operating free-air temperature range, $V_{CC} = 1.5V$, $C_L = 50pF$ (unless otherwise noted) (see [Load Circuit and Voltage Waveforms](#))

PARAMETER	FROM (INPUT)	TO (OUTPUT)	-55°C to 125°C		-40°C to 85°C		UNIT
			MIN	MAX	MIN	MAX	
t_{PLH}	D	Y	169		152		ns
t_{PHL}			169		152		
t_{PLH}	D	W	186		169		ns
t_{PHL}			186		169		
t_{PLH}	A, B, or C	Y	228		207		ns
t_{PHL}			228		207		
t_{PLH}	A, B, or C	W	245		223		ns
t_{PHL}			245		223		
t_{PLH}	\bar{G}	Y	153		139		ns
t_{PHL}			153		139		

CD74AC151

ZHCSWU1A - MARCH 2003 - REVISED JULY 2024

 over recommended operating free-air temperature range, $V_{CC} = 1.5V$, $C_L = 50pF$ (unless otherwise noted) (see [Load Circuit and Voltage Waveforms](#))

PARAMETER	FROM (INPUT)	TO (OUTPUT)	-55°C to 125°C		-40°C to 85°C		UNIT
			MIN	MAX	MIN	MAX	
t_{PLH}	\bar{G}	W			153		ns
t_{PHL}			169		153		

4.7 Switching Characteristics, $V_{CC} = 3.3V \pm 0.3V$

 over recommended operating free-air temperature range, $V_{CC} = 3.3V \pm 0.3V$, $C_L = 50pF$ (unless otherwise noted) (see [Load Circuit and Voltage Waveforms](#))

PARAMETER	FROM (INPUT)	TO (OUTPUT)	-55°C to 125°C		-40°C to 85°C		UNIT
			MIN	MAX	MIN	MAX	
t_{PLH}	D	Y	4.7	18.9	4.9	17.1	ns
t_{PHL}			4.7	18.9	4.9	17.1	
t_{PLH}	D	W	5.2	20.9	5.4	19	ns
t_{PHL}			5.2	20.9	5.4	19	
t_{PLH}	A, B, or C	Y	6.4	25.5	6.6	23.2	ns
t_{PHL}			6.4	25.5	6.6	23.2	
t_{PLH}	A, B, or C	W	6.9	27.4	7.1	24.9	ns
t_{PHL}			6.9	27.4	7.1	24.9	
t_{PLH}	\bar{G}	Y	4.3	17.1	4.4	15.5	ns
t_{PHL}			4.3	17.1	4.4	15.5	
t_{PLH}	\bar{G}	W	4.7	18.9	4.9	17.2	ns
t_{PHL}			4.7	18.9	4.9	17.2	

4.8 Switching Characteristics, $V_{CC} = 5V \pm 0.5V$

 over recommended operating free-air temperature range, $V_{CC} = 5V \pm 0.5V$, $C_L = 50pF$ (unless otherwise noted) (see [Load Circuit and Voltage Waveforms](#))

PARAMETER	FROM (INPUT)	TO (OUTPUT)	-55°C to 125°C		-40°C to 85°C		UNIT
			MIN	MAX	MIN	MAX	
t_{PLH}	D	Y	3.4	13.5	3.5	12.3	ns
t_{PHL}			3.4	13.5	3.5	12.3	
t_{PLH}	D	W	3.7	14.9	3.8	13.5	ns
t_{PHL}			3.7	14.9	3.8	13.5	
t_{PLH}	A, B, or C	Y	4.6	18.2	4.7	16.5	ns
t_{PHL}			4.6	18.2	4.7	16.5	
t_{PLH}	A, B, or C	W	4.9	19.6	5.1	17.8	ns
t_{PHL}			4.9	19.6	5.1	17.8	
t_{PLH}	\bar{G}	Y	3.1	12.2	3.1	11.1	ns
t_{PHL}			3.1	12.2	3.1	11.1	
t_{PLH}	\bar{G}	W	3.4	13.5	3.5	12.3	ns
t_{PHL}			3.4	13.5	3.5	12.3	

4.9 Operating Characteristics
 $V_{CC} = 5V$, $T_A = 25^\circ C$

PARAMETER		TYP	UNIT
C_{pd}	Power dissipation capacitance	120	pF

5 Parameter Measurement Information

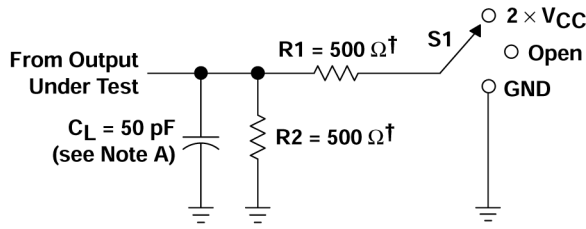

† When $V_{CC} = 1.5\text{ V}$, $R1 = R2 = 1\text{ k}\Omega$

LOAD CIRCUIT

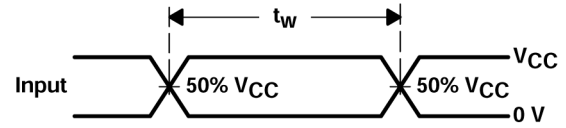

VOLTAGE WAVEFORMS
PULSE DURATION

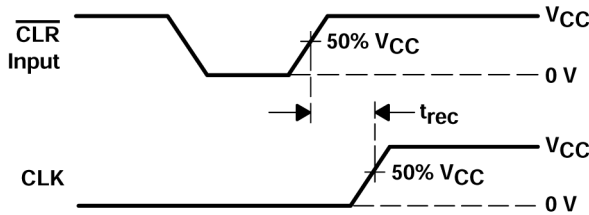

VOLTAGE WAVEFORMS
RECOVERY TIME

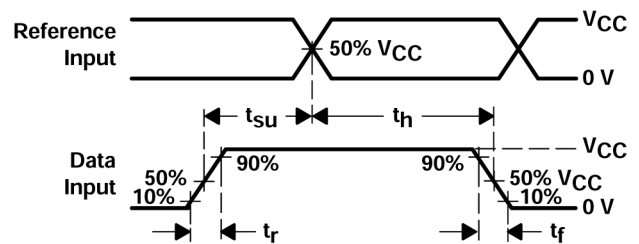

VOLTAGE WAVEFORMS
SETUP AND HOLD AND INPUT RISE AND FALL TIMES

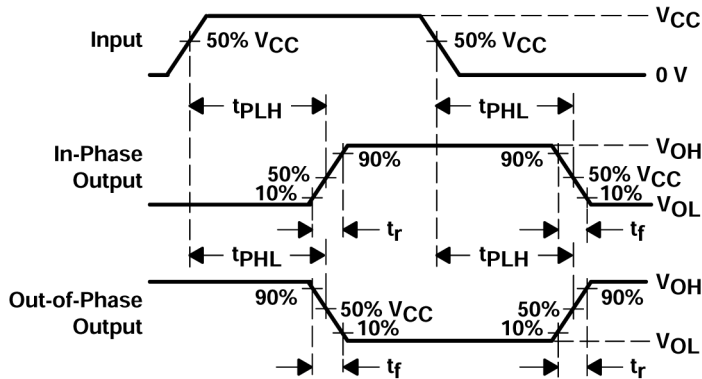

VOLTAGE WAVEFORMS
PROPAGATION DELAY AND OUTPUT TRANSITION TIMES

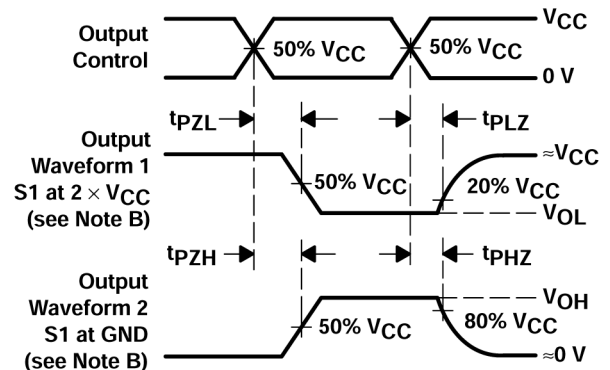

VOLTAGE WAVEFORMS
OUTPUT ENABLE AND DISABLE TIMES

- C_L includes probe and test-fixture capacitance.
- Waveform 1 is for an output with internal conditions such that the output is low except when disabled by the output control. Waveform 2 is for an output with internal conditions such that the output is high except when disabled by the output control.
- All input pulses are supplied by generators having the following characteristics: $PRR \leq 1\text{ MHz}$, $Z_0 = 50\ \Omega$, $t_r = 3\text{ ns}$, $t_f = 3\text{ ns}$. Phase relationships between waveforms are arbitrary.
- For clock inputs, f_{max} is measured with the input duty cycle at 50%.
- The outputs are measured one at a time with one input transition per measurement.
- t_{PLH} and t_{PHL} are the same as t_{pd} .
- t_{pZL} and t_{pZH} are the same as t_{en} .
- t_{PLZ} and t_{PHZ} are the same as t_{dis} .
- All parameters and waveforms are not applicable to all devices.

图 5-1. Load Circuit and Voltage Waveforms

TEST	S1
t_{PLH}/t_{PHL}	Open
t_{PLZ}/t_{PZL}	$2 \times V_{CC}$
t_{PHZ}/t_{PZH}	GND

6 Detailed Description

6.1 Functional Block Diagram



图 6-1. Logic Diagram (Positive Logic)

6.2 Device Functional Modes

表 6-1. Function Table

INPUTS			OUTPUTS		
SELECT			STROBE \bar{G}	Y	W
C	B	A			
X	X	X	H	L	H
L	L	L	L	D0	$\bar{D}0$
L	L	H	L	D1	$\bar{D}1$
L	H	L	L	D2	$\bar{D}2$
L	H	H	L	D3	$\bar{D}3$
H	L	L	L	D4	$\bar{D}4$
H	L	H	L	D5	$\bar{D}5$
H	H	L	L	D6	$\bar{D}6$
H	H	H	L	D7	$\bar{D}7$

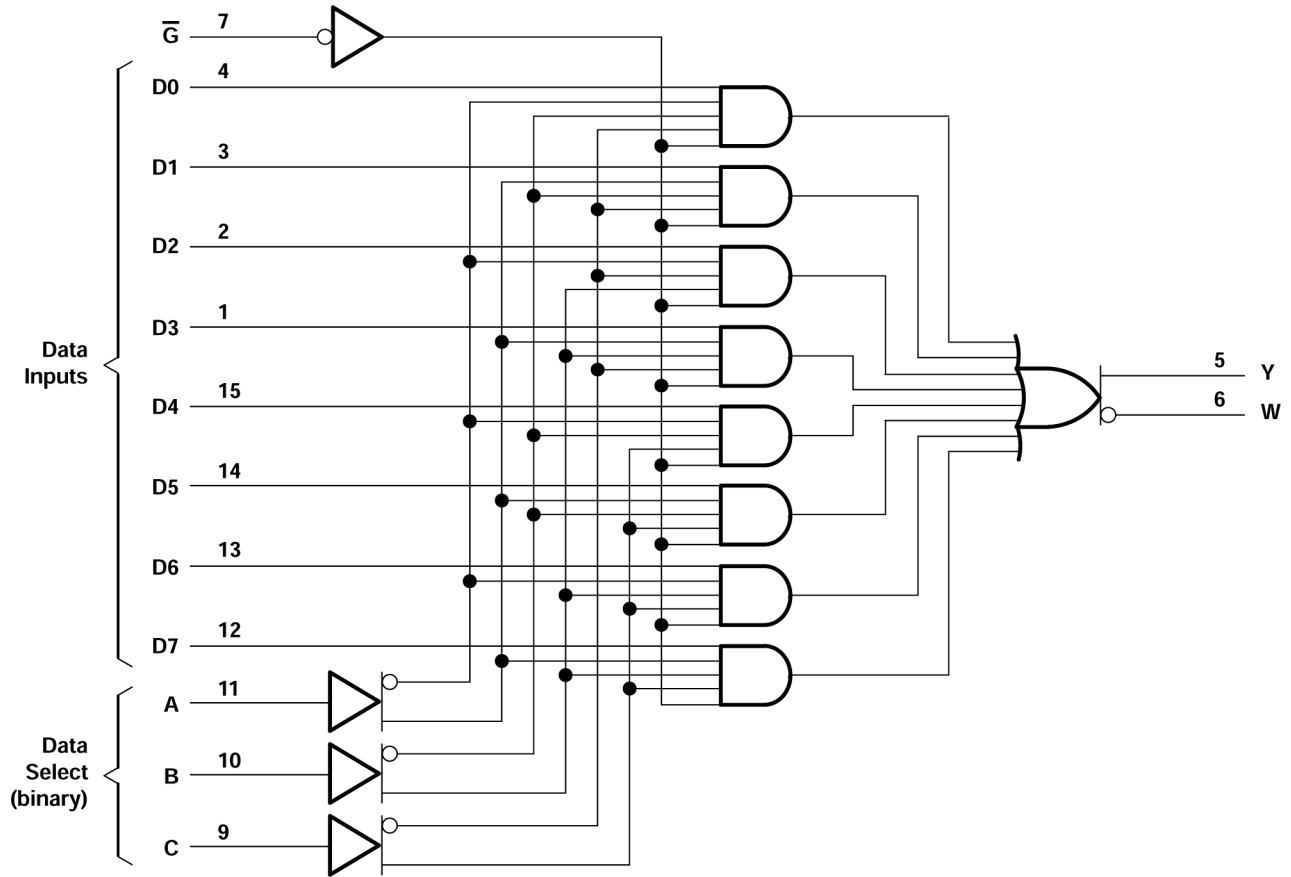
7 Application and Implementation

备注

Information in the following applications sections is not part of the TI component specification, and TI does not warrant its accuracy or completeness. TI's customers are responsible for determining suitability of components for their purposes, as well as validating and testing their design implementation to confirm system functionality.

7.1 Power Supply Recommendations

The power supply can be any voltage between the minimum and maximum supply voltage rating located in the *Recommended Operating Conditions*. Each V_{CC} terminal should have a good bypass capacitor to prevent power disturbance. A 0.1- μ F capacitor is recommended for this device. It is acceptable to parallel multiple bypass caps to reject different frequencies of noise. The 0.1- μ F and 1- μ F capacitors are commonly used in parallel. The bypass capacitor should be installed as close to the power terminal as possible for best results.

7.2 Layout

7.2.1 Layout Guidelines

When using multiple-input and multiple-channel logic devices inputs must not ever be left floating. In many cases, functions or parts of functions of digital logic devices are unused; for example, when only two inputs of a triple-input AND gate are used or only 3 of the 4 buffer gates are used. Such unused input pins must not be left unconnected because the undefined voltages at the outside connections result in undefined operational states. All unused inputs of digital logic devices must be connected to a logic high or logic low voltage, as defined by the input voltage specifications, to prevent them from floating. The logic level that must be applied to any particular unused input depends on the function of the device. Generally, the inputs are tied to GND or V_{CC} , whichever makes more sense for the logic function or is more convenient.

8 Device and Documentation Support

TI offers an extensive line of development tools. Tools and software to evaluate the performance of the device, generate code, and develop solutions are listed below.

8.1 Documentation Support (Analog)

8.1.1 Related Documentation

The table below lists quick access links. Categories include technical documents, support and community resources, tools and software, and quick access to sample or buy.

表 8-1. Related Links

PARTS	PRODUCT FOLDER	SAMPLE & BUY	TECHNICAL DOCUMENTS	TOOLS & SOFTWARE	SUPPORT & COMMUNITY
CD74AC151	Click here	Click here	Click here	Click here	Click here

8.2 接收文档更新通知

要接收文档更新通知，请导航至 ti.com 上的器件产品文件夹。点击 [通知](#) 进行注册，即可每周接收产品信息更改摘要。有关更改的详细信息，请查看任何已修订文档中包含的修订历史记录。

8.3 支持资源

[TI E2E™ 中文支持论坛](#) 是工程师的重要参考资料，可直接从专家处获得快速、经过验证的解答和设计帮助。搜索现有解答或提出自己的问题，获得所需的快速设计帮助。

链接的内容由各个贡献者“按原样”提供。这些内容并不构成 TI 技术规范，并且不一定反映 TI 的观点；请参阅 TI 的 [使用条款](#)。

8.4 Trademarks

TI E2E™ is a trademark of Texas Instruments.

所有商标均为其各自所有者的财产。

8.5 静电放电警告



静电放电 (ESD) 会损坏这个集成电路。德州仪器 (TI) 建议通过适当的预防措施处理所有集成电路。如果不遵守正确的处理和安装程序，可能会损坏集成电路。

ESD 的损坏小至导致微小的性能降级，大至整个器件故障。精密的集成电路可能更容易受到损坏，这是因为非常细微的参数更改都可能会导致器件与其发布的规格不相符。

8.6 术语表

[TI 术语表](#) 本术语表列出并解释了术语、首字母缩略词和定义。

9 Revision History

注：以前版本的页码可能与当前版本的页码不同

Changes from Revision * (March 2003) to Revision A (July 2024)	Page
• 添加了封装信息表、引脚功能表、ESD 等级表、热性能信息表、器件功能模式、“应用和实施”部分、器件和文档支持部分以及机械、封装和可订购信息部分.....	1
• Updated R ^θ JA values: D = 73 to 119.9, all values in °C/W.....	5

10 Mechanical, Packaging, and Orderable Information

The following pages include mechanical, packaging, and orderable information. This information is the most current data available for the designated devices. This data is subject to change without notice and revision of this document. For browser-based versions of this data sheet, refer to the left-hand navigation.

PACKAGING INFORMATION

Orderable Device	Status (1)	Package Type	Package Drawing	Pins	Package Qty	Eco Plan (2)	Lead finish/ Ball material (6)	MSL Peak Temp (3)	Op Temp (°C)	Device Marking (4/5)	Samples
CD74AC151E	ACTIVE	PDIP	N	16	25	RoHS & Green	NIPDAU	N / A for Pkg Type	-55 to 125	CD74AC151E	Samples
CD74AC151M96	ACTIVE	SOIC	D	16	2500	RoHS & Green	NIPDAU	Level-1-260C-UNLIM	-55 to 125	AC151M	Samples

(1) The marketing status values are defined as follows:

ACTIVE: Product device recommended for new designs.

LIFEBUY: TI has announced that the device will be discontinued, and a lifetime-buy period is in effect.

NRND: Not recommended for new designs. Device is in production to support existing customers, but TI does not recommend using this part in a new design.

PREVIEW: Device has been announced but is not in production. Samples may or may not be available.

OBSOLETE: TI has discontinued the production of the device.

(2) **RoHS:** TI defines "RoHS" to mean semiconductor products that are compliant with the current EU RoHS requirements for all 10 RoHS substances, including the requirement that RoHS substance do not exceed 0.1% by weight in homogeneous materials. Where designed to be soldered at high temperatures, "RoHS" products are suitable for use in specified lead-free processes. TI may reference these types of products as "Pb-Free".

RoHS Exempt: TI defines "RoHS Exempt" to mean products that contain lead but are compliant with EU RoHS pursuant to a specific EU RoHS exemption.

Green: TI defines "Green" to mean the content of Chlorine (Cl) and Bromine (Br) based flame retardants meet JS709B low halogen requirements of <=1000ppm threshold. Antimony trioxide based flame retardants must also meet the <=1000ppm threshold requirement.

(3) MSL, Peak Temp. - The Moisture Sensitivity Level rating according to the JEDEC industry standard classifications, and peak solder temperature.

(4) There may be additional marking, which relates to the logo, the lot trace code information, or the environmental category on the device.

(5) Multiple Device Markings will be inside parentheses. Only one Device Marking contained in parentheses and separated by a "-" will appear on a device. If a line is indented then it is a continuation of the previous line and the two combined represent the entire Device Marking for that device.

(6) Lead finish/Ball material - Orderable Devices may have multiple material finish options. Finish options are separated by a vertical ruled line. Lead finish/Ball material values may wrap to two lines if the finish value exceeds the maximum column width.

Important Information and Disclaimer:The information provided on this page represents TI's knowledge and belief as of the date that it is provided. TI bases its knowledge and belief on information provided by third parties, and makes no representation or warranty as to the accuracy of such information. Efforts are underway to better integrate information from third parties. TI has taken and continues to take reasonable steps to provide representative and accurate information but may not have conducted destructive testing or chemical analysis on incoming materials and chemicals. TI and TI suppliers consider certain information to be proprietary, and thus CAS numbers and other limited information may not be available for release.

In no event shall TI's liability arising out of such information exceed the total purchase price of the TI part(s) at issue in this document sold by TI to Customer on an annual basis.

TAPE AND REEL INFORMATION

QUADRANT ASSIGNMENTS FOR PIN 1 ORIENTATION IN TAPE

*All dimensions are nominal

Device	Package Type	Package Drawing	Pins	SPQ	Reel Diameter (mm)	Reel Width W1 (mm)	A0 (mm)	B0 (mm)	K0 (mm)	P1 (mm)	W (mm)	Pin1 Quadrant
CD74AC151M96	SOIC	D	16	2500	330.0	16.4	6.5	10.3	2.1	8.0	16.0	Q1

TAPE AND REEL BOX DIMENSIONS

*All dimensions are nominal

Device	Package Type	Package Drawing	Pins	SPQ	Length (mm)	Width (mm)	Height (mm)
CD74AC151M96	SOIC	D	16	2500	353.0	353.0	32.0

TUBE

*All dimensions are nominal

Device	Package Name	Package Type	Pins	SPQ	L (mm)	W (mm)	T (μm)	B (mm)
CD74AC151E	N	PDIP	16	25	506	13.97	11230	4.32
CD74AC151E	N	PDIP	16	25	506	13.97	11230	4.32

D (R-PDSO-G16)

PLASTIC SMALL OUTLINE



4040047-6/M 06/11

- NOTES:
- A. All linear dimensions are in inches (millimeters).
 - B. This drawing is subject to change without notice.
 - Body length does not include mold flash, protrusions, or gate burrs. Mold flash, protrusions, or gate burrs shall not exceed 0.006 (0,15) each side.
 - Body width does not include interlead flash. Interlead flash shall not exceed 0.017 (0,43) each side.
 - E. Reference JEDEC MS-012 variation AC.

N (R-PDIP-T**)

PLASTIC DUAL-IN-LINE PACKAGE

16 PINS SHOWN



4040049/E 12/2002

- NOTES:
- A. All linear dimensions are in inches (millimeters).
 - B. This drawing is subject to change without notice.
 - C Falls within JEDEC MS-001, except 18 and 20 pin minimum body length (Dim A).
 - D The 20 pin end lead shoulder width is a vendor option, either half or full width.

重要声明和免责声明

TI“按原样”提供技术和可靠性数据（包括数据表）、设计资源（包括参考设计）、应用或其他设计建议、网络工具、安全信息和其他资源，不保证没有瑕疵且不做任何明示或暗示的担保，包括但不限于对适销性、某特定用途方面的适用性或不侵犯任何第三方知识产权的暗示担保。

这些资源可供使用 TI 产品进行设计的熟练开发人员使用。您将自行承担以下全部责任：(1) 针对您的应用选择合适的 TI 产品，(2) 设计、验证并测试您的应用，(3) 确保您的应用满足相应标准以及任何其他功能安全、信息安全、监管或其他要求。

这些资源如有变更，恕不另行通知。TI 授权您仅可将这些资源用于研发本资源所述的 TI 产品的应用。严禁对这些资源进行其他复制或展示。您无权使用任何其他 TI 知识产权或任何第三方知识产权。您应全额赔偿因在这些资源的使用中对 TI 及其代表造成的任何索赔、损害、成本、损失和债务，TI 对此概不负责。

TI 提供的产品受 [TI 的销售条款](#) 或 [ti.com](#) 上其他适用条款/TI 产品随附的其他适用条款的约束。TI 提供这些资源并不会扩展或以其他方式更改 TI 针对 TI 产品发布的适用的担保或担保免责声明。

TI 反对并拒绝您可能提出的任何其他或不同的条款。

邮寄地址：Texas Instruments, Post Office Box 655303, Dallas, Texas 75265

Copyright © 2024，德州仪器 (TI) 公司