

CY54FCT138T, CY74FCT138T 1-OF-8 DECODERS

SCCS013B – MAY 1994 – REVISED OCTOBER 2001

- Function, Pinout, and Drive Compatible With FCT and F Logic
- Reduced V_{OH} (Typically = 3.3 V) Versions of Equivalent FCT Functions
- Edge-Rate Control Circuitry for Significantly Improved Noise Characteristics
- I_{off} Supports Partial-Power-Down Mode Operation
- Matched Rise and Fall Times
- Fully Compatible With TTL Input and Output Logic Levels
- Dual 1-of-8 Decoder With Enables
- ESD Protection Exceeds JESD 22
 - 2000-V Human-Body Model (A114-A)
 - 200-V Machine Model (A115-A)
 - 1000-V Charged-Device Model (C101)
- CY54FCT138T
 - 32-mA Output Sink Current
 - 12-mA Output Source Current
- CY74FCT138T
 - 64-mA Output Sink Current
 - 32-mA Output Source Current

CY54FCT138T . . . D PACKAGE
CY74FCT138T . . . Q OR SO PACKAGE
(TOP VIEW)

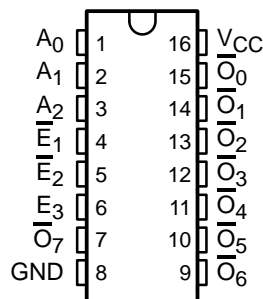

CY54FCT138T . . . L PACKAGE
(TOP VIEW)

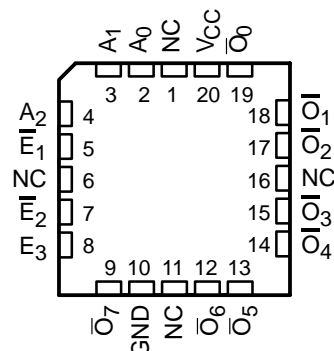

NC – No internal connection

description

The 'FCT138T devices are 1-of-8 decoders. These devices accept three binary weighted inputs (A_0 , A_1 , A_2) and, when enabled, provide eight mutually exclusive active-low outputs (\overline{O}_0 – \overline{O}_7). The 'FCT138T devices feature three enable inputs: two active low (\overline{E}_1 , \overline{E}_2) and one active high (E_3).

All outputs are high unless \overline{E}_1 and \overline{E}_2 are low and E_3 is high. This multiple-enable function allows easy parallel expansion of the device to a 1-of-32 (five lines to 32 lines) decoder with just four 'FCT138T devices and one inverter.

These devices are fully specified for partial-power-down applications using I_{off} . The I_{off} circuitry disables the outputs, preventing damaging current backflow through the device when it is powered down.

PIN DESCRIPTION

NAME	DESCRIPTION
A	Address inputs
\overline{E}_1 , \overline{E}_2	Enable inputs (active low)
E_3	Enable input (active high)
\overline{O}	Outputs



Please be aware that an important notice concerning availability, standard warranty, and use in critical applications of Texas Instruments semiconductor products and disclaimers thereto appears at the end of this data sheet.

PRODUCTION DATA information is current as of publication date. Products conform to specifications per the terms of Texas Instruments standard warranty. Production processing does not necessarily include testing of all parameters.

 **TEXAS
INSTRUMENTS**

POST OFFICE BOX 655303 • DALLAS, TEXAS 75265

Copyright © 2001, Texas Instruments Incorporated
On products compliant to MIL-PRF-38535, all parameters are tested unless otherwise noted. On all other products, production processing does not necessarily include testing of all parameters.

CY54FCT138T, CY74FCT138T 1-OF-8 DECODERS

SCCS013B – MAY 1994 – REVISED OCTOBER 2001

ORDERING INFORMATION

T _A	PACKAGE†		SPEED (ns)	ORDERABLE PART NUMBER	TOP-SIDE MARKING
-40°C to 85°C	QSOP – Q	Tape and reel	5	CY74FCT138CTQCT	FT138-3
	SOIC – SO	Tube	5	CY74FCT138CTSOC	FCT138C
		Tape and reel	5	CY74FCT138CTSOCT	
	QSOP – Q	Tape and reel	5.8	CY74FCT138ATQCT	FT138-1
		SOIC – SO	Tube	5.8	CY74FCT138ATSOC
	Tape and reel		5.8	CY74FCT138ATSOCT	
-55°C to 125°C	QSOP – Q	Tape and reel	9	CY74FCT138TQCT	FT138
	LCC – L	Tube	6	CY54FCT138CTLMB	
	LCC – L	Tube	12	CY54FCT138TLMB	
	CDIP – D	Tube	12	CY54FCT138TDMB	

† Package drawings, standard packing quantities, thermal data, symbolization, and PCB design guidelines are available at www.ti.com/sc/package.

FUNCTION TABLE

INPUTS						OUTPUTS							
\bar{E}_1	\bar{E}_2	E ₃	A ₀	A ₁	A ₂	\bar{O}_0	\bar{O}_1	\bar{O}_2	\bar{O}_3	\bar{O}_4	\bar{O}_5	\bar{O}_6	\bar{O}_7
H	X	X	X	X	X	H	H	H	H	H	H	H	H
X	H	X	X	X	X	H	H	H	H	H	H	H	H
X	X	L	X	X	X	H	H	H	H	H	H	H	H
L	L	H	L	L	L	L	H	H	H	H	H	H	H
L	L	H	H	L	L	H	L	H	H	H	H	H	H
L	L	H	L	H	L	H	H	L	H	H	H	H	H
L	L	H	H	H	L	H	H	H	H	L	H	H	H
L	L	H	L	H	H	H	H	H	H	H	H	L	H
L	L	H	H	H	H	H	H	H	H	H	H	H	L

H = High logic level, L = Low logic level, X = Don't care



logic diagram (positive logic)

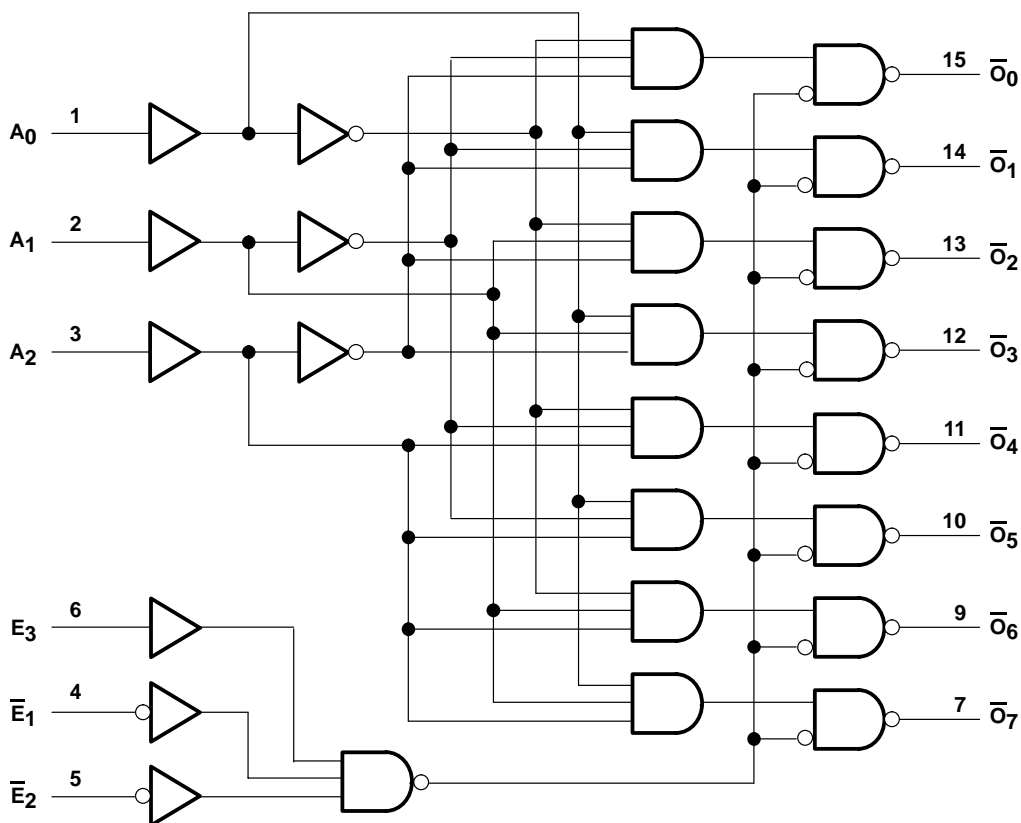

Pin numbers shown are for the D, Q, and SO packages.

absolute maximum ratings over operating free-air temperature range (unless otherwise noted)†

Supply voltage range to ground potential	-0.5 V to 7 V
DC input voltage range	-0.5 V to 7 V
DC output voltage range	-0.5 V to 7 V
DC output current (maximum sink current/pin)	120 mA
Package thermal impedance, θ_{JA} (see Note 1): Q package	90°C/W
SO package	57°C/W
Ambient temperature range with power applied, T_A	-65°C to 135°C
Storage temperature range, T_{STG}	-65°C to 150°C

† Stresses beyond those listed under “absolute maximum ratings” may cause permanent damage to the device. These are stress ratings only, and functional operation of the device at these or any other conditions beyond those indicated under “recommended operating conditions” is not implied. Exposure to absolute-maximum-rated conditions for extended periods may affect device reliability.

NOTE 1: The package thermal impedance is calculated in accordance with JESD 51-7.

CY54FCT138T, CY74FCT138T 1-OF-8 DECODERS

SCCS013B – MAY 1994 – REVISED OCTOBER 2001

recommended operating conditions (see Note 2)

		CY54FCT138T			CY74FCT138T			UNIT
		MIN	NOM	MAX	MIN	NOM	MAX	
V_{CC}	Supply voltage	4.5	5	5.5	4.75	5	5.25	V
V_{IH}	High-level input voltage	2			2			V
V_{IL}	Low-level input voltage			0.8			0.8	V
I_{OH}	High-level output current			-12			-32	mA
I_{OL}	Low-level output current			32			64	mA
T_A	Operating free-air temperature	-55		125	-40		85	°C

NOTE 2: All unused inputs of the device must be held at V_{CC} or GND to ensure proper device operation.

electrical characteristics over recommended operating free-air temperature range (unless otherwise noted)

PARAMETER	TEST CONDITIONS	CY54FCT138T			CY74FCT138T			UNIT
		MIN	TYP†	MAX	MIN	TYP†	MAX	
V_{IK}	$V_{CC} = 4.5\text{ V}$, $I_{IN} = -18\text{ mA}$		-0.7	-1.2				V
	$V_{CC} = 4.75\text{ V}$, $I_{IN} = -18\text{ mA}$				-0.7	-1.2		
V_{OH}	$V_{CC} = 4.5\text{ V}$, $I_{OH} = -12\text{ mA}$	2.4	3.3					V
	$V_{CC} = 4.75\text{ V}$	$I_{OH} = -32\text{ mA}$			2			
		$I_{OH} = -15\text{ mA}$			2.4	3.3		
V_{OL}	$V_{CC} = 4.5\text{ V}$, $I_{OL} = 32\text{ mA}$		0.3	0.55				V
	$V_{CC} = 4.75\text{ V}$, $I_{OL} = 64\text{ mA}$				0.3	0.55		
V_{hys}	All inputs		0.2		0.2			V
I_I	$V_{CC} = 5.5\text{ V}$, $V_{IN} = V_{CC}$			5				μA
	$V_{CC} = 5.25\text{ V}$, $V_{IN} = V_{CC}$					5		
I_{IH}	$V_{CC} = 5.5\text{ V}$, $V_{IN} = 2.7\text{ V}$			± 1				μA
	$V_{CC} = 5.25\text{ V}$, $V_{IN} = 2.7\text{ V}$					± 1		
I_{IL}	$V_{CC} = 5.5\text{ V}$, $V_{IN} = 0.5\text{ V}$			± 1				μA
	$V_{CC} = 5.25\text{ V}$, $V_{IN} = 0.5\text{ V}$					± 1		
$I_{OS}‡$	$V_{CC} = 5.5\text{ V}$, $V_{OUT} = 0\text{ V}$	-60	-120	-225				mA
	$V_{CC} = 5.25\text{ V}$, $V_{OUT} = 0\text{ V}$				-60	-120	-225	
I_{off}	$V_{CC} = 0\text{ V}$, $V_{OUT} = 4.5\text{ V}$			± 1			± 1	μA
I_{CC}	$V_{CC} = 5.5\text{ V}$, $V_{IN} \leq 0.2\text{ V}$, $V_{IN} \geq V_{CC} - 0.2\text{ V}$		0.1	0.2				mA
	$V_{CC} = 5.25\text{ V}$, $V_{IN} \leq 0.2\text{ V}$, $V_{IN} \geq V_{CC} - 0.2\text{ V}$				0.1	0.2		
ΔI_{CC}	$V_{CC} = 5.5\text{ V}$, $V_{IN} = 3.4\text{ V}§$, $f_1 = 0$, Outputs open		0.5	2				mA
	$V_{CC} = 5.25\text{ V}$, $V_{IN} = 3.4\text{ V}§$, $f_1 = 0$, Outputs open				0.5	2		
$I_{CCD}¶$	$V_{CC} = 5.5\text{ V}$, Outputs open, One bit switching at 50% duty cycle, $V_{IN} \leq 0.2\text{ V}$ or $V_{IN} \geq V_{CC} - 0.2\text{ V}$		0.06	0.12				mA/ MHz
	$V_{CC} = 5.25\text{ V}$, Outputs open, One bit switching at 50% duty cycle, $V_{IN} \leq 0.2\text{ V}$ or $V_{IN} \geq V_{CC} - 0.2\text{ V}$				0.06	0.12		

† Typical values are at $V_{CC} = 5\text{ V}$, $T_A = 25^\circ\text{C}$.

‡ Not more than one output should be shorted at a time. Duration of short should not exceed one second. The use of high-speed test apparatus and/or sample-and-hold techniques are preferable to minimize internal chip heating and more accurately reflect operational values. Otherwise, prolonged shorting of a high output can raise the chip temperature well above normal and cause invalid readings in other parametric tests. In any sequence of parameter tests, I_{OS} tests should be performed last.

§ Per TTL-driven input ($V_{IN} = 3.4\text{ V}$); all other inputs at V_{CC} or GND

¶ This parameter is derived for use in total power-supply calculations.



electrical characteristics over recommended operating free-air temperature range (unless otherwise noted) (continued)

PARAMETER	TEST CONDITIONS			CY54FCT138T		CY74FCT138T		UNIT
				MIN	TYP†	MAX	MIN	
I _{C#}	V _{CC} = 5.5 V, Outputs open, Switch \bar{E}_1 , \bar{E}_2 , or E ₃	One output switching at f ₁ = 10 MHz at 50% duty cycle	V _{IN} ≤ 0.2 V or V _{IN} ≥ V _{CC} – 0.2 V	0.7	1.4			mA
			V _{IN} = 3.4 V or GND	1	2.4			
	V _{CC} = 5.25 V, Outputs open, Switch \bar{E}_1 , \bar{E}_2 , or E ₃	One output switching at f ₁ = 10 MHz at 50% duty cycle	V _{IN} ≤ 0.2 V or V _{IN} ≥ V _{CC} – 0.2 V			0.7	1.4	
			V _{IN} = 3.4 V or GND			1	2.4	
C _i				5	10	5	10	pF
C _O				9	12	9	12	pF

† Typical values are at V_{CC} = 5 V, T_A = 25°C.

$$\# I_C = I_{CC} + \Delta I_{CC} \times D_H \times N_T + I_{CCD} (f_0/2 + f_1 \times N_1)$$

Where:

I_C = Total supply current

I_{CC} = Power-supply current with CMOS input levels

ΔI_{CC} = Power-supply current for a TTL high input (V_{IN} = 3.4 V)

D_H = Duty cycle for TTL inputs high

N_T = Number of TTL inputs at D_H

I_{CCD} = Dynamic current caused by an input transition pair (HLH or LHL)

f₀ = Clock frequency for registered devices, otherwise zero

f₁ = Input signal frequency

N₁ = Number of inputs changing at f₁

All currents are in milliamperes and all frequencies are in megahertz.

|| Values for these conditions are examples of the I_{CC} formula.

switching characteristics over operating free-air temperature range (see Figure 1)

PARAMETER	FROM (INPUT)	TO (OUTPUT)	CY54FCT138T		CY54FCT138CT		UNIT
			MIN	MAX	MIN	MAX	
t _{PLH}	A	\bar{O}	1.5	12	1.5	6	ns
t _{PHL}			1.5	12	1.5	6	
t _{PLH}	\bar{E}_1 or \bar{E}_2	\bar{O}	1.5	12.5	1.5	6.1	ns
t _{PHL}			1.5	12.5	1.5	6.1	
t _{PLH}	E ₃	\bar{O}	1.5	12.5	1.5	6.1	ns
t _{PHL}			1.5	12.5	1.5	6.1	

switching characteristics over operating free-air temperature range (see Figure 1)

PARAMETER	FROM (INPUT)	TO (OUTPUT)	CY74FCT138T		CY74FCT138AT		CY74FCT138CT		UNIT
			MIN	MAX	MIN	MAX	MIN	MAX	
t _{PLH}	A	\bar{O}	1.5	9	1.5	5.8	1.5	5	ns
t _{PHL}			1.5	9	1.5	5.8	1.5	5	
t _{PLH}	\bar{E}_1 or \bar{E}_2	\bar{O}	1.5	9	1.5	5.9	1.5	5	ns
t _{PHL}			1.5	9	1.5	5.9	1.5	5	
t _{PLH}	E ₃	\bar{O}	1.5	9	1.5	5.9	1.5	5	ns
t _{PHL}			1.5	9	1.5	5.9	1.5	5	

CY54FCT138T, CY74FCT138T 1-OF-8 DECODERS

SCCS013B – MAY 1994 – REVISED OCTOBER 2001

PARAMETER MEASUREMENT INFORMATION

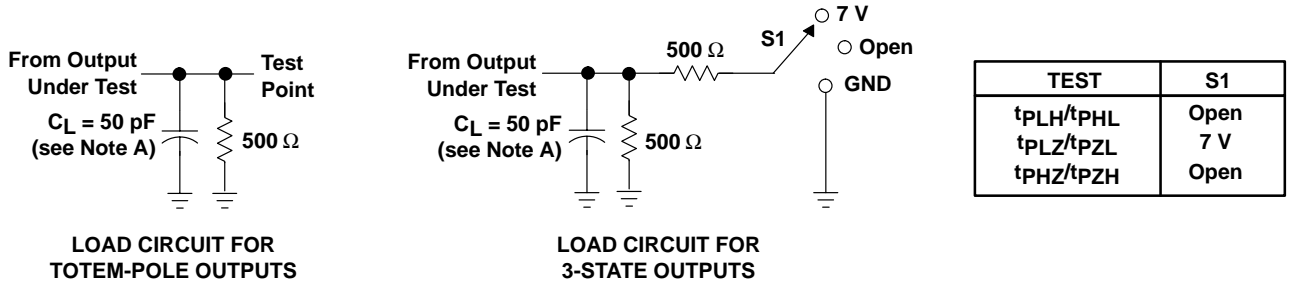

LOAD CIRCUIT FOR
TOTEM-POLE OUTPUTS

LOAD CIRCUIT FOR
3-STATE OUTPUTS

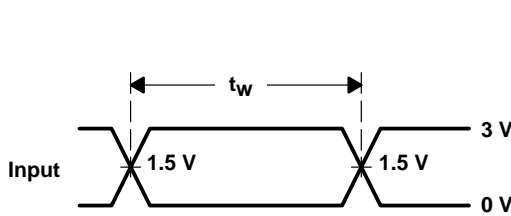

VOLTAGE WAVEFORMS
PULSE DURATION

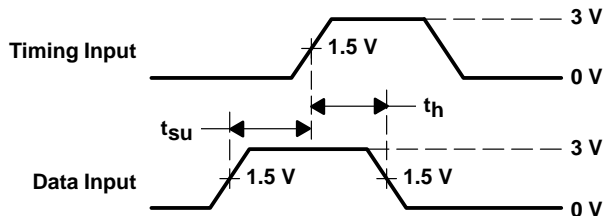

VOLTAGE WAVEFORMS
SETUP AND HOLD TIMES

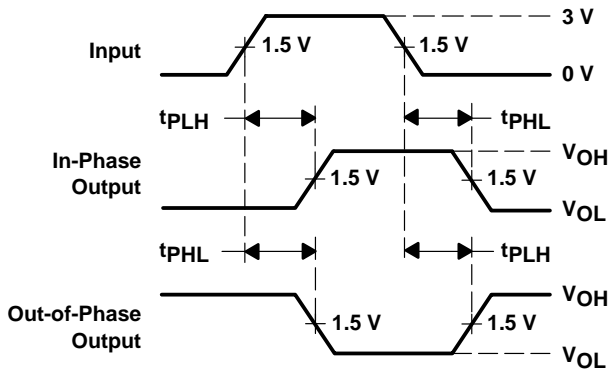

VOLTAGE WAVEFORMS
PROPAGATION DELAY TIMES
INVERTING AND NONINVERTING OUTPUTS

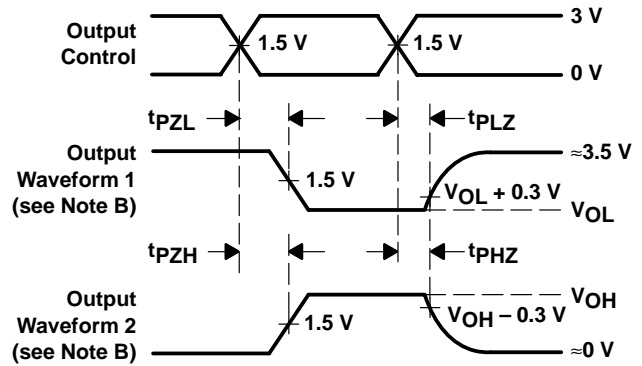

VOLTAGE WAVEFORMS
ENABLE AND DISABLE TIMES
LOW- AND HIGH-LEVEL ENABLING

- NOTES: A. C_L includes probe and jig capacitance.
 B. Waveform 1 is for an output with internal conditions such that the output is low except when disabled by the output control. Waveform 2 is for an output with internal conditions such that the output is high except when disabled by the output control.
 C. The outputs are measured one at a time with one input transition per measurement.

Figure 1. Load Circuit and Voltage Waveforms

PACKAGING INFORMATION

Orderable Device	Status (1)	Package Type	Package Drawing	Pins	Package Qty	Eco Plan (2)	Lead finish/ Ball material (6)	MSL Peak Temp (3)	Op Temp (°C)	Device Marking (4/5)	Samples
5962-9223302M2A	ACTIVE	LCCC	FK	20	55	Non-RoHS & Green	SNPB	N / A for Pkg Type	-55 to 125	5962-9223302M2A CY54FCT 138TLMB	Samples
5962-9223302MEA	ACTIVE	CDIP	J	16	25	Non-RoHS & Green	SNPB	N / A for Pkg Type	-55 to 125	5962-9223302MEA CY54FCT138TDMB	Samples
5962-9223306M2A	ACTIVE	LCCC	FK	20	55	Non-RoHS & Green	SNPB	N / A for Pkg Type	-55 to 125	5962-9223306M2A CY54FCT 138CTLMB	Samples
5962-9223306MEA	ACTIVE	CDIP	J	16	25	Non-RoHS & Green	SNPB	N / A for Pkg Type	-55 to 125	5962-9223306MEA A	Samples
CY54FCT138CTLMB	ACTIVE	LCCC	FK	20	55	Non-RoHS & Green	SNPB	N / A for Pkg Type	-55 to 125	5962-9223306M2A CY54FCT 138CTLMB	Samples
CY54FCT138TDMB	ACTIVE	CDIP	J	16	25	Non-RoHS & Green	SNPB	N / A for Pkg Type	-55 to 125	5962-9223302MEA A CY54FCT138TDMB	Samples
CY54FCT138TLMB	ACTIVE	LCCC	FK	20	55	Non-RoHS & Green	SNPB	N / A for Pkg Type	-55 to 125	5962-9223302M2A CY54FCT 138TLMB	Samples
CY74FCT138ATQCT	ACTIVE	SSOP	DBQ	16	2500	RoHS & Green	NIPDAU	Level-2-260C-1 YEAR	-40 to 85	FT138-1	Samples
CY74FCT138ATSOC	ACTIVE	SOIC	DW	16	40	RoHS & Green	NIPDAU	Level-1-260C-UNLIM	-40 to 85	FCT138A	Samples
CY74FCT138ATSOCG4	ACTIVE	SOIC	DW	16	40	RoHS & Green	NIPDAU	Level-1-260C-UNLIM	-40 to 85	FCT138A	Samples
CY74FCT138ATSOCT	ACTIVE	SOIC	DW	16	2000	RoHS & Green	NIPDAU	Level-1-260C-UNLIM	-40 to 85	FCT138A	Samples
CY74FCT138CTQCT	ACTIVE	SSOP	DBQ	16	2500	RoHS & Green	NIPDAU	Level-2-260C-1 YEAR	-40 to 85	FT138-3	Samples
CY74FCT138CTSOC	ACTIVE	SOIC	DW	16	40	RoHS & Green	NIPDAU	Level-1-260C-UNLIM	-40 to 85	FCT138C	Samples

Orderable Device	Status (1)	Package Type	Package Drawing	Pins	Package Qty	Eco Plan (2)	Lead finish/ Ball material (6)	MSL Peak Temp (3)	Op Temp (°C)	Device Marking (4/5)	Samples
CY74FCT138TQCT	ACTIVE	SSOP	DBQ	16	2500	RoHS & Green	NIPDAU	Level-2-260C-1 YEAR	-40 to 85	FT138	Samples

(1) The marketing status values are defined as follows:

ACTIVE: Product device recommended for new designs.

LIFEBUY: TI has announced that the device will be discontinued, and a lifetime-buy period is in effect.

NRND: Not recommended for new designs. Device is in production to support existing customers, but TI does not recommend using this part in a new design.

PREVIEW: Device has been announced but is not in production. Samples may or may not be available.

OBSOLETE: TI has discontinued the production of the device.

(2) **RoHS:** TI defines "RoHS" to mean semiconductor products that are compliant with the current EU RoHS requirements for all 10 RoHS substances, including the requirement that RoHS substance do not exceed 0.1% by weight in homogeneous materials. Where designed to be soldered at high temperatures, "RoHS" products are suitable for use in specified lead-free processes. TI may reference these types of products as "Pb-Free".

RoHS Exempt: TI defines "RoHS Exempt" to mean products that contain lead but are compliant with EU RoHS pursuant to a specific EU RoHS exemption.

Green: TI defines "Green" to mean the content of Chlorine (Cl) and Bromine (Br) based flame retardants meet JS709B low halogen requirements of <=1000ppm threshold. Antimony trioxide based flame retardants must also meet the <=1000ppm threshold requirement.

(3) MSL, Peak Temp. - The Moisture Sensitivity Level rating according to the JEDEC industry standard classifications, and peak solder temperature.

(4) There may be additional marking, which relates to the logo, the lot trace code information, or the environmental category on the device.

(5) Multiple Device Markings will be inside parentheses. Only one Device Marking contained in parentheses and separated by a "~" will appear on a device. If a line is indented then it is a continuation of the previous line and the two combined represent the entire Device Marking for that device.

(6) Lead finish/Ball material - Orderable Devices may have multiple material finish options. Finish options are separated by a vertical ruled line. Lead finish/Ball material values may wrap to two lines if the finish value exceeds the maximum column width.

Important Information and Disclaimer:The information provided on this page represents TI's knowledge and belief as of the date that it is provided. TI bases its knowledge and belief on information provided by third parties, and makes no representation or warranty as to the accuracy of such information. Efforts are underway to better integrate information from third parties. TI has taken and continues to take reasonable steps to provide representative and accurate information but may not have conducted destructive testing or chemical analysis on incoming materials and chemicals. TI and TI suppliers consider certain information to be proprietary, and thus CAS numbers and other limited information may not be available for release.

In no event shall TI's liability arising out of such information exceed the total purchase price of the TI part(s) at issue in this document sold by TI to Customer on an annual basis.

TAPE AND REEL INFORMATION

QUADRANT ASSIGNMENTS FOR PIN 1 ORIENTATION IN TAPE

*All dimensions are nominal

Device	Package Type	Package Drawing	Pins	SPQ	Reel Diameter (mm)	Reel Width W1 (mm)	A0 (mm)	B0 (mm)	K0 (mm)	P1 (mm)	W (mm)	Pin1 Quadrant
CY74FCT138ATQCT	SSOP	DBQ	16	2500	330.0	12.5	6.4	5.2	2.1	8.0	12.0	Q1
CY74FCT138ATSOCT	SOIC	DW	16	2000	330.0	16.4	10.75	10.7	2.7	12.0	16.0	Q1
CY74FCT138CTQCT	SSOP	DBQ	16	2500	330.0	12.5	6.4	5.2	2.1	8.0	12.0	Q1
CY74FCT138TQCT	SSOP	DBQ	16	2500	330.0	12.5	6.4	5.2	2.1	8.0	12.0	Q1

TAPE AND REEL BOX DIMENSIONS

*All dimensions are nominal

Device	Package Type	Package Drawing	Pins	SPQ	Length (mm)	Width (mm)	Height (mm)
CY74FCT138ATQCT	SSOP	DBQ	16	2500	340.5	338.1	20.6
CY74FCT138ATSOCT	SOIC	DW	16	2000	350.0	350.0	43.0
CY74FCT138CTQCT	SSOP	DBQ	16	2500	340.5	338.1	20.6
CY74FCT138TQCT	SSOP	DBQ	16	2500	340.5	338.1	20.6

TUBE

*All dimensions are nominal

Device	Package Name	Package Type	Pins	SPQ	L (mm)	W (mm)	T (μm)	B (mm)
5962-9223302M2A	FK	LCCC	20	55	506.98	12.06	2030	NA
5962-9223306M2A	FK	LCCC	20	55	506.98	12.06	2030	NA
CY54FCT138CTLMB	FK	LCCC	20	55	506.98	12.06	2030	NA
CY54FCT138TLMB	FK	LCCC	20	55	506.98	12.06	2030	NA
CY74FCT138ATSOC	DW	SOIC	16	40	506.98	12.7	4826	6.6
CY74FCT138ATSOCG4	DW	SOIC	16	40	506.98	12.7	4826	6.6
CY74FCT138CTSOC	DW	SOIC	16	40	506.98	12.7	4826	6.6

IMPORTANT NOTICE AND DISCLAIMER

TI PROVIDES TECHNICAL AND RELIABILITY DATA (INCLUDING DATA SHEETS), DESIGN RESOURCES (INCLUDING REFERENCE DESIGNS), APPLICATION OR OTHER DESIGN ADVICE, WEB TOOLS, SAFETY INFORMATION, AND OTHER RESOURCES "AS IS" AND WITH ALL FAULTS, AND DISCLAIMS ALL WARRANTIES, EXPRESS AND IMPLIED, INCLUDING WITHOUT LIMITATION ANY IMPLIED WARRANTIES OF MERCHANTABILITY, FITNESS FOR A PARTICULAR PURPOSE OR NON-INFRINGEMENT OF THIRD PARTY INTELLECTUAL PROPERTY RIGHTS.

These resources are intended for skilled developers designing with TI products. You are solely responsible for (1) selecting the appropriate TI products for your application, (2) designing, validating and testing your application, and (3) ensuring your application meets applicable standards, and any other safety, security, regulatory or other requirements.

These resources are subject to change without notice. TI grants you permission to use these resources only for development of an application that uses the TI products described in the resource. Other reproduction and display of these resources is prohibited. No license is granted to any other TI intellectual property right or to any third party intellectual property right. TI disclaims responsibility for, and you will fully indemnify TI and its representatives against, any claims, damages, costs, losses, and liabilities arising out of your use of these resources.

TI's products are provided subject to [TI's Terms of Sale](#) or other applicable terms available either on [ti.com](https://www.ti.com) or provided in conjunction with such TI products. TI's provision of these resources does not expand or otherwise alter TI's applicable warranties or warranty disclaimers for TI products.

TI objects to and rejects any additional or different terms you may have proposed.

Mailing Address: Texas Instruments, Post Office Box 655303, Dallas, Texas 75265
Copyright © 2023, Texas Instruments Incorporated