

DRV8837C 1A 低电压 H 桥驱动器

1 特性

- 独立的 H 桥电机
 - 驱动直流电机或其他负载
 - 低 MOSFET 导通电阻: HS + LS 1 Ω
- 1A 最大驱动电流
- 工作电源电压范围: 0V 至 11V
- 标准脉宽调制 (PWM) 接口 (IN1/IN2)
- 低功耗休眠模式, 休眠电流最大值仅为 120nA
 - nSLEEP 引脚
- 小型封装尺寸
 - 8 晶圆级小外形无引线 (WSON) (带外露散热焊盘)
 - 2.0mm x 2.0mm
- 保护特性
 - VCC 欠压闭锁 (UVLO)
 - 过流保护 (OCP)
 - 热关断 (TSD)

2 应用范围

- 摄像机
- 数字单镜头反光 (DSLR) 镜头
- 消费类产品
- 玩具
- 机器人技术
- 医疗设备

3 说明

DRV8837C 器件提供了一套集成型电机驱动器解决方案, 主要面向照相机、消费类产品、玩具以及其他低压和电池供电类运动控制应用。此器件能够驱动一个直流电机或其他诸如螺线管的器件。输出驱动器模块由配置为 H 桥的 N 沟道功率 MOSFET 组成, 用以驱动电机绕组。一个内部电荷泵被用来生成所需的栅极驱动电压。

DRV8837C 器件可以提供高达 1A 的输出电流。该器件的电机电源电压为 0 至 11V, 其控制逻辑工作电源轨为 1.8V 至 5V。

DRV8837C 器件有一个 PWM (IN/IN) 输入接口。

此外, 还提供用于过流保护、短路保护、欠压闭锁和过热保护的内部关断功能。

器件信息⁽¹⁾

器件型号	封装	封装尺寸 (标称值)
DRV8837C	WSON (8)	2.00mm x 2.00mm

(1) 要了解所有可用封装, 请见数据表末尾的可订购产品附录。

DRV8837C 简化框图

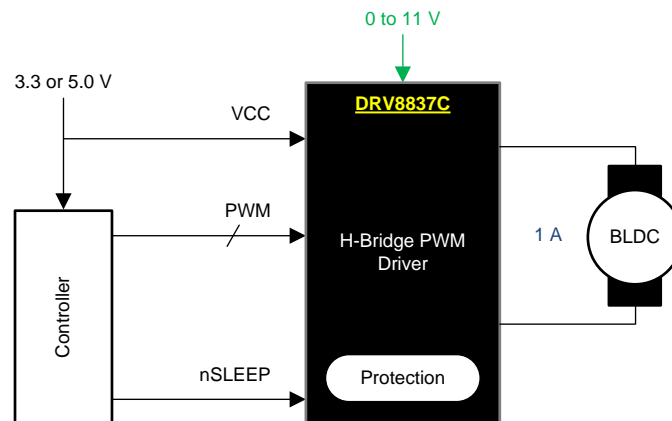

Copyright © 2016, Texas Instruments Incorporated



目录

1	特性	1	8	Application and Implementation	11
2	应用范围	1	8.1	Application Information	11
3	说明	1	8.2	Typical Application	11
4	修订历史记录	2	9	Power Supply Recommendations	12
5	Pin Configuration and Functions	3	9.1	Bulk Capacitance	12
6	Specifications	4	10	Layout	14
6.1	Absolute Maximum Ratings	4	10.1	Layout Guidelines	14
6.2	ESD Ratings	4	10.2	Layout Example	14
6.3	Recommended Operating Conditions	4	10.3	Power Dissipation	14
6.4	Thermal Information	4	11	器件和文档支持	15
6.5	Electrical Characteristics	5	11.1	文档支持	15
6.6	Timing Requirements	6	11.2	接收文档更新通知	15
6.7	Typical Characteristics	7	11.3	社区资源	15
7	Detailed Description	8	11.4	商标	15
7.1	Overview	8	11.5	静电放电警告	15
7.2	Functional Block Diagram	8	11.6	Glossary	15
7.3	Feature Description	9	12	机械、封装和可订购信息	15
7.4	Device Functional Modes	10			

4 修订历史记录

注：之前版本的页码可能与当前版本有所不同。

Changes from Original (July 2016) to Revision A	Page
• 已更改 器件状态，从产品预览更改为量产数据	1

5 Pin Configuration and Functions

DSG Package
8-Pin WSON With Exposed Thermal Pad
Top View

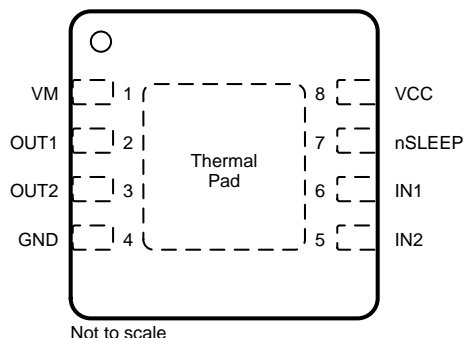

Pin Functions

PIN		TYPE	DESCRIPTION
NAME	NO.		
POWER AND GROUND			
GND	4	PWR	Device ground This pin must be connected to the PCB ground.
VCC	8	PWR	Logic power supply Bypass this pin to the GND pin with a 0.1- μ F ceramic capacitor rated for VCC.
VM	1	PWR	Motor power supply Bypass this pin to the GND pin with a 0.1- μ F ceramic capacitor rated for VM.
CONTROL			
IN1	6	I	IN1 input
IN2	5	I	IN2 input
nSLEEP	7	I	Sleep mode input When this pin is in logic low, the device enters low-power sleep mode. The device operates normally when this pin is logic high. The pin has an internal pulldown resistor to GND.
OUTPUT			
OUT1	2	O	Motor output
OUT2	3	O	Connect this pin to the motor winding.

6 Specifications

6.1 Absolute Maximum Ratings

Over operating free-air temperature range (unless otherwise noted)⁽¹⁾⁽²⁾

		MIN	MAX	UNIT
Motor power-supply voltage	V _M	-0.3	12	V
Logic power-supply voltage	V _{CC}	-0.3	7	V
Control pin voltage	IN1, IN2, nSLEEP	-0.5	7	V
Peak drive current	OUT1, OUT2	Internally limited		A
Operating virtual junction temperature, T _J		-40	150	°C
Storage temperature, T _{stg}		-60	150	°C

- (1) Stresses beyond those listed under *Absolute Maximum Ratings* may cause permanent damage to the device. These are stress ratings only, and functional operation of the device at these or any other conditions beyond those indicated under *Recommended Operating Conditions* is not implied. Exposure to absolute-maximum-rated conditions for extended periods may affect device reliability.
- (2) All voltage values are with respect to network ground pin.

6.2 ESD Ratings

		VALUE	UNIT
V _(ESD)	Electrostatic discharge	Human-body model (HBM), per ANSI/ESDA/JEDEC JS-001 ⁽¹⁾	±4000
		Charged-device model (CDM), per JEDEC specification JESD22-C101 ⁽²⁾	±1000

- (1) JEDEC document JEP155 states that 500-V HBM allows safe manufacturing with a standard ESD control process.
- (2) JEDEC document JEP157 states that 250-V CDM allows safe manufacturing with a standard ESD control process.

6.3 Recommended Operating Conditions

Over operating free-air temperature range (unless otherwise noted)

		MIN	MAX	UNIT
V _{VM}	Motor power-supply voltage	0	11	V
V _{CC}	Logic power-supply voltage	1.8	7	V
I _{OUT}	Motor peak current	0	1	A
f _{PWM}	Externally applied PWM frequency	0	250	kHz
V _{LOGIC}	Logic level input voltage	0	5.5	V
T _A	Operating ambient temperature	-40	85	°C

6.4 Thermal Information

over operating free-air temperature range (unless otherwise noted)

THERMAL METRIC ⁽¹⁾		DRV8837C	UNIT
		DSG (WSON)	
		8 PINS	
R _{θJA}	Junction-to-ambient thermal resistance	60.9	°C/W
R _{θJC(top)}	Junction-to-case (top) thermal resistance	71.4	°C/W
R _{θJB}	Junction-to-board thermal resistance	32.2	°C/W
ψ _{JT}	Junction-to-top characterization parameter	1.6	°C/W
ψ _{JB}	Junction-to-board characterization parameter	32.8	°C/W
R _{θJC(bot)}	Junction-to-case (bottom) thermal resistance	9.8	°C/W

- (1) For more information about traditional and new thermal metrics, see the [Semiconductor and IC Package Thermal Metrics](#) application report.

6.5 Electrical Characteristics

 $T_A = 25^\circ\text{C}$, over recommended operating conditions unless otherwise noted

PARAMETER		TEST CONDITIONS	MIN	TYP	MAX	UNIT
POWER SUPPLIES (VM, VCC)						
V_{VM}	VM operating voltage		0		11	V
I_{VM}	VM operating supply current	$V_{VM} = 5\text{ V}; V_{CC} = 3\text{ V};$ No PWM		40	100	μA
		$V_{VM} = 5\text{ V}; V_{CC} = 3\text{ V};$ 50 kHz PWM		0.8	1.5	mA
I_{VMQ}	VM sleep mode supply current	$V_{VM} = 5\text{ V}; V_{CC} = 3\text{ V};$ $n\text{SLEEP} = 0$		30	95	nA
V_{CC}	V_{CC} operating voltage		1.8		7	V
I_{VCC}	V_{CC} operating supply current	$V_{VM} = 5\text{ V}; V_{CC} = 3\text{ V};$ No PWM		300	500	μA
		$V_{VM} = 5\text{ V}; V_{CC} = 3\text{ V};$ 50 kHz PWM		0.7	1.5	mA
I_{VCCQ}	V_{CC} sleep mode supply current	$V_{VM} = 5\text{ V}; V_{CC} = 3\text{ V};$ $n\text{SLEEP} = 0$		5	25	nA
CONTROL INPUTS (IN1/PH, IN2/EN, nSLEEP)						
V_{IL}	Input logic-low voltage				$0.25 \times V_{CC}$	V
V_{IH}	Input logic-high voltage		$0.5 \times V_{CC}$			V
V_{HYS}	Input logic hysteresis			$0.08 \times V_{CC}$		V
I_{IL}	Input logic-low current	$V_{INx} = 0\text{ V}$	-5		5	μA
I_{IH}	Input logic-high current	$V_{INx} = 3.3\text{ V}$			50	μA
R_{PD}	Pulldown resistance			100		k Ω
MOTOR DRIVER OUTPUTS (OUT1, OUT2)						
$R_{DS(ON)}$	HS + LS FET on-resistance	$V_{VM} = 5\text{ V}; V_{CC} = 3.3\text{ V};$ $I_O = 200\text{ mA}; T_J = 25^\circ\text{C}$		1000		m Ω
I_{OFF}	Off-state leakage current	$V_{OUTx} = 0\text{ V}$	-200		200	nA
PROTECTION CIRCUITS						
V_{UVLO}	V_{CC} undervoltage lockout	V_{CC} falling			1.7	V
		V_{CC} rising			1.8	V
I_{OCP}	Overcurrent protection trip level		1.2			A
t_{DEG}	Overcurrent deglitch time			1		μs
t_{RETRY}	Overcurrent retry time			1		ms
$T_{TSD}^{(1)}$	Thermal shutdown temperature	Die temperature T_J	150	160	180	$^\circ\text{C}$

(1) Not tested in production; limits are based on characterization data

DRV8837C

ZHCSFB2A–JULY 2016–REVISED JULY 2016

www.ti.com.cn
6.6 Timing Requirements
 $T_A = 25^\circ\text{C}$, $V_{VM} = 5\text{ V}$, $V_{CC} = 3\text{ V}$, $R_L = 20\ \Omega$

NO.			MIN	MAX	UNIT
1	t_7	Output enable time		300	ns
2	t_8	Output disable time		300	ns
3	t_9	Delay time, INx high to OUTx high		160	ns
4	t_{10}	Delay time, INx low to OUTx low		160	ns
5	t_{11}	Output rise time	20	188	ns
6	t_{12}	Output fall time	20	188	ns
—	t_{wake}	Wake time, nSLEEP rising edge to part active		30	μs

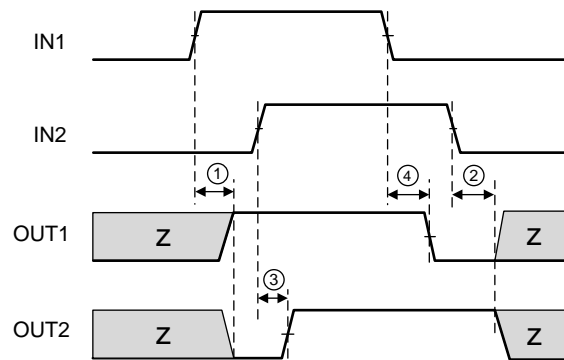

DRV8837C

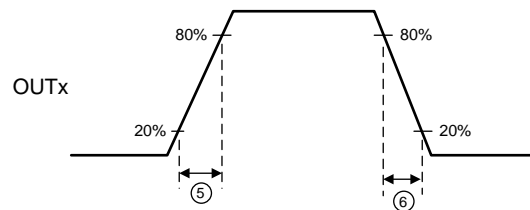
图 1. Input and Output Timing for DRV8837C

6.7 Typical Characteristics

Plots generated using characterization data.

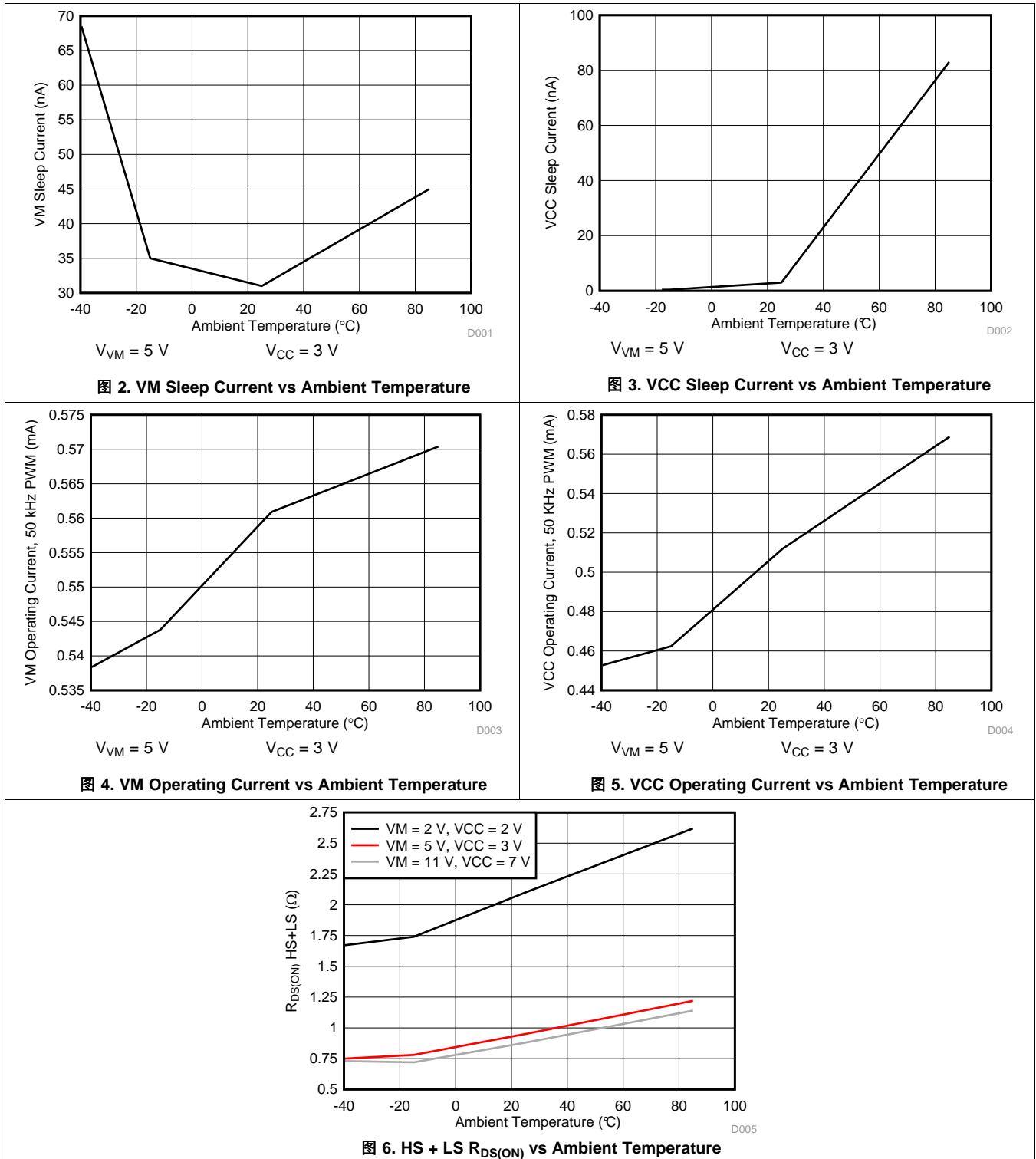

7 Detailed Description

7.1 Overview

The DRV8837C device is an H-bridge driver that can drive one DC motor or other devices like solenoids. The outputs are controlled using a PWM interface (IN1/IN2).

A low-power sleep mode is included, which can be enabled using the nSLEEP pin.

This device greatly reduces the component count of motor driver systems by integrating the necessary driver FETs and FET control circuitry into a single device. In addition, the DRV8837C device adds protection features beyond traditional discrete implementations: undervoltage lockout, overcurrent protection, and thermal shutdown.

7.2 Functional Block Diagram

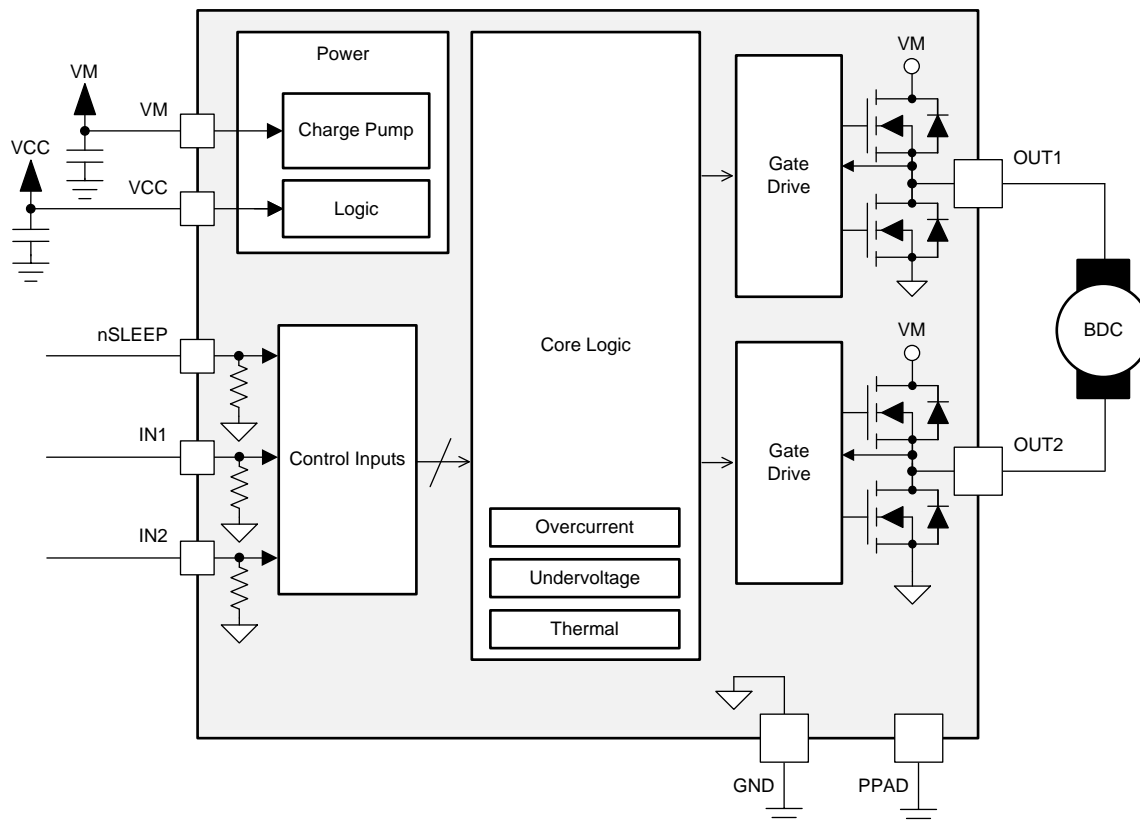

Copyright © 2016, Texas Instruments Incorporated

7.3 Feature Description

7.3.1 Bridge Control

The DRV8837C device is controlled using a PWM input interface, also called an IN/IN interface. Each output is controlled by a corresponding input pin.

表 1 shows the logic for the DRV8837C device.

表 1. DRV8837C Device Logic

nSLEEP	IN1	IN2	OUT1	OUT2	FUNCTION (DC MOTOR)
0	X	X	Z	Z	Coast
1	0	0	Z	Z	Coast
1	0	1	L	H	Reverse
1	1	0	H	L	Forward
1	1	1	L	L	Brake

7.3.2 Sleep Mode

If the nSLEEP pin is brought to a logic-low state, the DRV8837C device enters a low-power sleep mode. In this state, all unnecessary internal circuitry is powered down.

7.3.3 Power Supplies and Input Pins

The input pins can be driven within the recommended operating conditions with or without the VCC, VM, or both power supplies present. No leakage current path exists to the supply. Each input pin has a weak pulldown resistor (approximately 100 kΩ) to ground.

The VCC and VM supplies can be applied and removed in any order. When the VCC supply is removed, the device enters a low-power state and draws very little current from the VM supply. The VCC and VM pins can be connected together if the supply voltage is between 1.8 and 7 V.

The VM voltage supply does not have any undervoltage-lockout protection (UVLO). As long as $V_{CC} > 1.8\text{ V}$, the internal device logic remains active which means that the VM pin voltage can drop to 0 V, however, the load may not be sufficiently driven at low VM voltages.

7.3.4 Protection Circuits

The DRV8837C is fully protected against VCC undervoltage, overcurrent, and overtemperature events.

VCC undervoltage lockout If at any time the voltage on the VCC pin falls below the undervoltage lockout threshold voltage, all FETs in the H-bridge are disabled. Operation resumes when the VCC pin voltage rises above the UVLO threshold.

Overcurrent protection (OCP) An analog current-limit circuit on each FET limits the current through the FET by removing the gate drive. If this analog current limit persists for longer than t_{DEG} , all FETs in the H-bridge are disabled. Operation resumes automatically after t_{RETRY} has elapsed. Overcurrent conditions are detected on both the high-side and low-side devices. A short to the VM pin, GND, or from the OUT1 pin to the OUT2 pin results in an overcurrent condition.

Thermal shutdown (TSD) If the die temperature exceeds safe limits, all FETs in the H-bridge are disabled. After the die temperature falls to a safe level, operation automatically resumes.

表 2. Fault Behavior

FAULT	CONDITION	H-BRIDGE	RECOVERY
VCC undervoltage (UVLO)	$V_{CC} < 1.7\text{ V}$	Disabled	$V_{CC} > 1.8\text{ V}$
Overcurrent (OCP)	$I_{OUT} > 1.2\text{ A (MIN)}$	Disabled (retries automatically)	t_{RETRY} elapses
Thermal Shutdown (TSD)	$T_J > 150^\circ\text{C (MIN)}$	Disabled (retries automatically)	$T_J < 150^\circ\text{C}$

7.4 Device Functional Modes

The DRV8837C device is active unless the nSLEEP pin is brought logic low. In sleep mode the H-bridge FETs are disabled Hi-Z. The DRV8837C device is brought out of sleep mode automatically if nSLEEP is brought logic high.

The H-bridge outputs are disabled during undervoltage lockout, overcurrent, and overtemperature fault conditions.

表 3. Operation Modes

MODE	CONDITION	H-BRIDGE
Operating	nSLEEP pin = 1	Operating
Sleep mode	nSLEEP pin = 0	Disabled
Fault encountered	Any fault condition met	Disabled (retries automatically)

8 Application and Implementation

注

Information in the following applications sections is not part of the TI component specification, and TI does not warrant its accuracy or completeness. TI's customers are responsible for determining suitability of components for their purposes. Customers should validate and test their design implementation to confirm system functionality.

8.1 Application Information

The DRV8837C device is used to drive one DC motor or other devices like solenoids. The following design procedure can be used to configure the DRV8837C device.

8.2 Typical Application

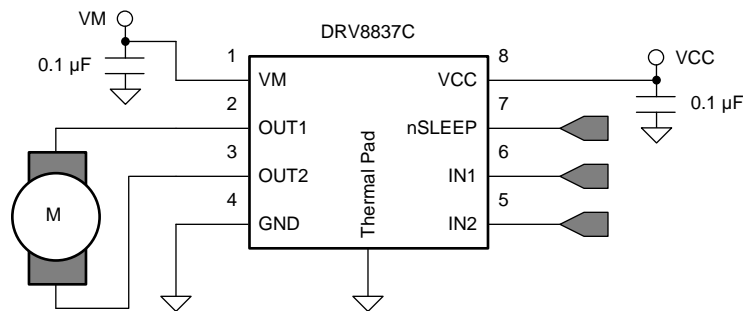

Copyright © 2016, Texas Instruments Incorporated

图 7. Schematic of DRV8837C Application

8.2.1 Design Requirements

表 4 lists the required parameters for a typical usage case.

表 4. System Design Requirements

DESIGN PARAMETER	REFERENCE	EXAMPLE VALUE
Motor supply voltage	VM	9 V
Logic supply voltage	VCC	3.3 V
Target RMS current	I_{OUT}	0.8 A

8.2.2 Detailed Design Procedure

8.2.2.1 Motor Voltage

The appropriate motor voltage depends on the ratings of the motor selected and the desired RPM. A higher voltage spins a brushed dc motor faster with the same PWM duty cycle applied to the power FETs. A higher voltage also increases the rate of current change through the inductive motor windings.

8.2.2.2 Low-Power Operation

When entering sleep mode, TI recommends setting all inputs as a logic low to minimize system power.

8.2.3 Application Curves



图 8. 50% Duty Cycle, Forward Direction



图 9. 50% Duty Cycle, Reverse Direction

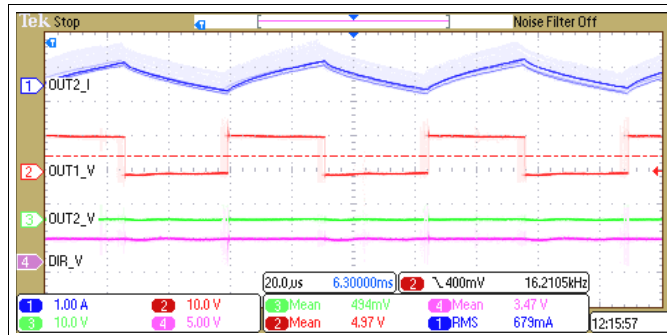

图 10. 20% Duty Cycle, Forward Direction

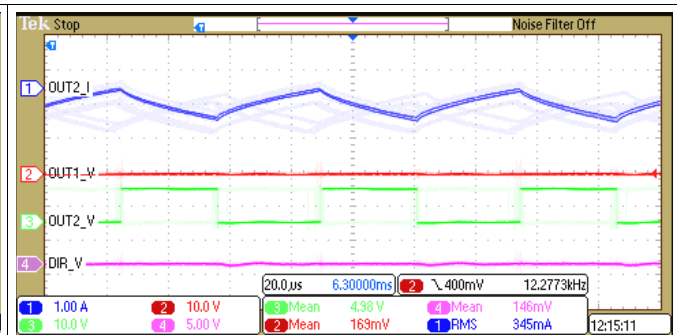

图 11. 20% Duty Cycle, Reverse Direction

9 Power Supply Recommendations

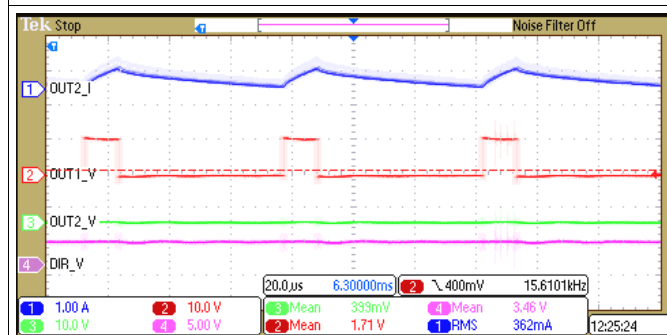
9.1 Bulk Capacitance

Having appropriate local bulk capacitance is an important factor in motor-drive system design. It is generally beneficial to have more bulk capacitance, while the disadvantages are increased cost and physical size.

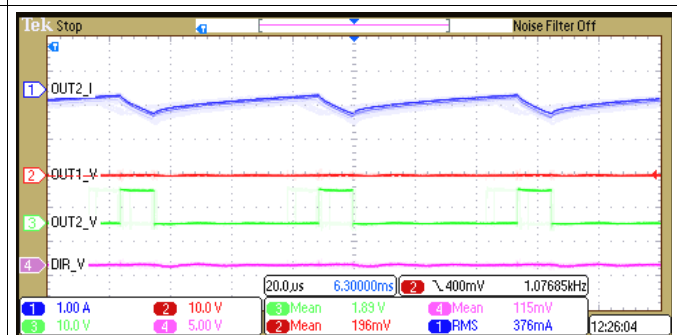
The amount of local capacitance needed depends on a variety of factors, including:

- The highest current required by the motor system
- The power-supply capacitance and ability to source current
- The amount of parasitic inductance between the power supply and motor system
- The acceptable voltage ripple
- The type of motor used (brushed dc, brushless dc, stepper)
- The motor braking method

The inductance between the power supply and motor drive system limits the rate at which current can change from the power supply. If the local bulk capacitance is too small, the system responds to excessive current demands or dumps from the motor with a change in voltage. When adequate bulk capacitance is used, the motor voltage remains stable and high current can be quickly supplied.

The data sheet generally provides a recommended value, but system-level testing is required to determine the appropriate size of bulk capacitor.

Bulk Capacitance (接下页)



图 12. Example Setup of Motor Drive System With External Power Supply

The voltage rating for bulk capacitors should be higher than the operating voltage, to provide margin for cases when the motor transfers energy to the supply

10 Layout

10.1 Layout Guidelines

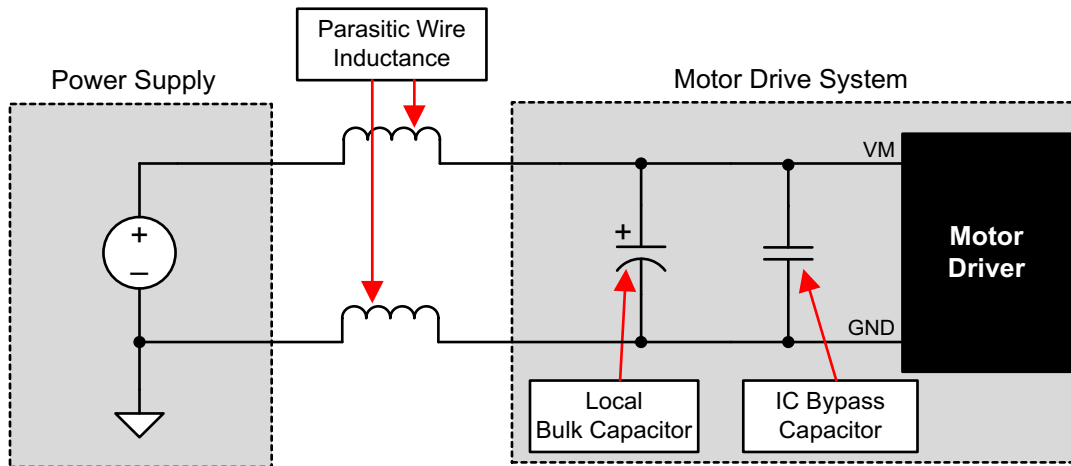
The VM and VCC pins should be bypassed to GND using low-ESR ceramic bypass capacitors with a recommended value of 0.1 μF rated for the VM and VCC supplies. These capacitors should be placed as close to the VM and VCC pins as possible with a thick trace or ground plane connection to the device GND pin. In addition bulk capacitance is required on the VM pin.

10.2 Layout Example



图 13. Simplified Layout Example

10.3 Power Dissipation

Power dissipation in the DRV8837C device is dominated by the power dissipated in the output FET resistance, or $R_{\text{DS(ON)}}$. Use 公式 1 to estimate the average power dissipation when running a brushed-DC motor.

$$P_{\text{TOT}} = R_{\text{DS(ON)}} \times (I_{\text{OUT(RMS)}})^2$$

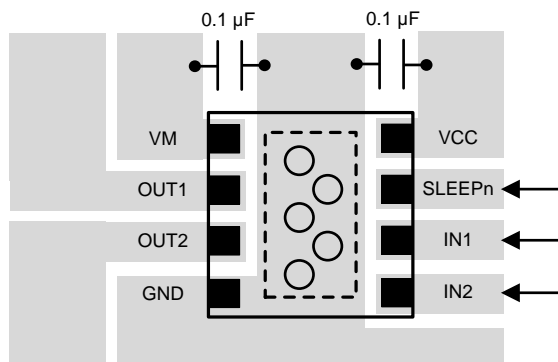
where

- P_{TOT} is the total power dissipation
 - $R_{\text{DS(ON)}}$ is the resistance of the HS plus LS FETs
 - $I_{\text{OUT(RMS)}}$ is the RMS or DC output current being supplied to the load
- (1)

The maximum amount of power that can be dissipated in the device is dependent on ambient temperature and heatsinking.

注

The value of $R_{\text{DS(ON)}}$ increases with temperature, so as the device heats, the power dissipation increases.

The DRV8837C device has thermal shutdown protection. If the die temperature exceeds approximately 150°C, the device is disabled until the temperature drops to a safe level.

Any tendency of the device to enter thermal shutdown is an indication of either excessive power dissipation, insufficient heatsinking, or too high an ambient temperature.

11 器件和文档支持

11.1 文档支持

11.1.1 相关文档

相关文档请参见以下部分：

- 《[计算电机驱动器功耗](#)》（文献编号：SLVA504）
- [用户指南《DRV8837C 评估模块》](#)（文献编号：SLVUAS3）。
- 《[了解电机驱动器电流额定值](#)》（文献编号：SLVA505）

11.2 接收文档更新通知

如需接收文档更新通知，请访问 www.ti.com.cn 网站上的器件产品文件夹。点击右上角的[提醒我 \(Alert me\)](#) 注册后，即可每周定期收到已更改的产品信息。有关更改的详细信息，请查阅已修订文档中包含的修订历史记录。

11.3 社区资源

The following links connect to TI community resources. Linked contents are provided "AS IS" by the respective contributors. They do not constitute TI specifications and do not necessarily reflect TI's views; see TI's [Terms of Use](#).

TI E2E™ Online Community *TI's Engineer-to-Engineer (E2E) Community*. Created to foster collaboration among engineers. At e2e.ti.com, you can ask questions, share knowledge, explore ideas and help solve problems with fellow engineers.

Design Support *TI's Design Support* Quickly find helpful E2E forums along with design support tools and contact information for technical support.

11.4 商标

E2E is a trademark of Texas Instruments.

All other trademarks are the property of their respective owners.

11.5 静电放电警告



ESD 可能会损坏该集成电路。德州仪器 (TI) 建议通过适当的预防措施处理所有集成电路。如果不遵守正确的处理措施和安装程序，可能会损坏集成电路。

ESD 的损坏小至导致微小的性能降级，大至整个器件故障。精密的集成电路可能更容易受到损坏，这是因为非常细微的参数更改都可能会导致器件与其发布的规格不相符。

11.6 Glossary

[SLYZ022](#) — *TI Glossary*.

This glossary lists and explains terms, acronyms, and definitions.

12 机械、封装和可订购信息

以下页中包括机械、封装和可订购信息。这些信息是针对指定器件可提供的最新数据。这些数据会在无通知且不对本文档进行修订的情况下发生改变。欲获得该数据表的浏览器版本，请查阅左侧的导航栏。

PACKAGING INFORMATION

Orderable Device	Status (1)	Package Type	Package Drawing	Pins	Package Qty	Eco Plan (2)	Lead finish/ Ball material (6)	MSL Peak Temp (3)	Op Temp (°C)	Device Marking (4/5)	Samples
DRV8837CDSGR	ACTIVE	WSON	DSG	8	3000	RoHS & Green	NIPDAU	Level-1-260C-UNLIM	-40 to 85	837C	Samples
DRV8837CDSGT	LIFEBUY	WSON	DSG	8	250	RoHS & Green	NIPDAU	Level-1-260C-UNLIM	-40 to 85	837C	

(1) The marketing status values are defined as follows:

ACTIVE: Product device recommended for new designs.

LIFEBUY: TI has announced that the device will be discontinued, and a lifetime-buy period is in effect.

NRND: Not recommended for new designs. Device is in production to support existing customers, but TI does not recommend using this part in a new design.

PREVIEW: Device has been announced but is not in production. Samples may or may not be available.

OBSOLETE: TI has discontinued the production of the device.

(2) **RoHS:** TI defines "RoHS" to mean semiconductor products that are compliant with the current EU RoHS requirements for all 10 RoHS substances, including the requirement that RoHS substance do not exceed 0.1% by weight in homogeneous materials. Where designed to be soldered at high temperatures, "RoHS" products are suitable for use in specified lead-free processes. TI may reference these types of products as "Pb-Free".

RoHS Exempt: TI defines "RoHS Exempt" to mean products that contain lead but are compliant with EU RoHS pursuant to a specific EU RoHS exemption.

Green: TI defines "Green" to mean the content of Chlorine (Cl) and Bromine (Br) based flame retardants meet JS709B low halogen requirements of <=1000ppm threshold. Antimony trioxide based flame retardants must also meet the <=1000ppm threshold requirement.

(3) MSL, Peak Temp. - The Moisture Sensitivity Level rating according to the JEDEC industry standard classifications, and peak solder temperature.

(4) There may be additional marking, which relates to the logo, the lot trace code information, or the environmental category on the device.

(5) Multiple Device Markings will be inside parentheses. Only one Device Marking contained in parentheses and separated by a "~" will appear on a device. If a line is indented then it is a continuation of the previous line and the two combined represent the entire Device Marking for that device.

(6) Lead finish/Ball material - Orderable Devices may have multiple material finish options. Finish options are separated by a vertical ruled line. Lead finish/Ball material values may wrap to two lines if the finish value exceeds the maximum column width.

Important Information and Disclaimer: The information provided on this page represents TI's knowledge and belief as of the date that it is provided. TI bases its knowledge and belief on information provided by third parties, and makes no representation or warranty as to the accuracy of such information. Efforts are underway to better integrate information from third parties. TI has taken and continues to take reasonable steps to provide representative and accurate information but may not have conducted destructive testing or chemical analysis on incoming materials and chemicals. TI and TI suppliers consider certain information to be proprietary, and thus CAS numbers and other limited information may not be available for release.

In no event shall TI's liability arising out of such information exceed the total purchase price of the TI part(s) at issue in this document sold by TI to Customer on an annual basis.

TAPE AND REEL INFORMATION

QUADRANT ASSIGNMENTS FOR PIN 1 ORIENTATION IN TAPE

*All dimensions are nominal

Device	Package Type	Package Drawing	Pins	SPQ	Reel Diameter (mm)	Reel Width W1 (mm)	A0 (mm)	B0 (mm)	K0 (mm)	P1 (mm)	W (mm)	Pin1 Quadrant
DRV8837CDSGR	WSON	DSG	8	3000	180.0	8.4	2.3	2.3	1.15	4.0	8.0	Q2
DRV8837CDSGR	WSON	DSG	8	3000	180.0	8.4	2.3	2.3	1.15	4.0	8.0	Q2
DRV8837CDSGT	WSON	DSG	8	250	180.0	8.4	2.3	2.3	1.15	4.0	8.0	Q2
DRV8837CDSGT	WSON	DSG	8	250	180.0	8.4	2.3	2.3	1.15	4.0	8.0	Q2

TAPE AND REEL BOX DIMENSIONS

*All dimensions are nominal

Device	Package Type	Package Drawing	Pins	SPQ	Length (mm)	Width (mm)	Height (mm)
DRV8837CDSGR	WSON	DSG	8	3000	182.0	182.0	20.0
DRV8837CDSGR	WSON	DSG	8	3000	210.0	185.0	35.0
DRV8837CDSGT	WSON	DSG	8	250	182.0	182.0	20.0
DRV8837CDSGT	WSON	DSG	8	250	210.0	185.0	35.0

GENERIC PACKAGE VIEW

DSG 8

WSON - 0.8 mm max height

2 x 2, 0.5 mm pitch

PLASTIC SMALL OUTLINE - NO LEAD

This image is a representation of the package family, actual package may vary.
Refer to the product data sheet for package details.



4224783/A

DSG0008A



PACKAGE OUTLINE

WSON - 0.8 mm max height

PLASTIC SMALL OUTLINE - NO LEAD

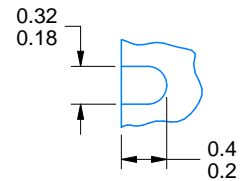
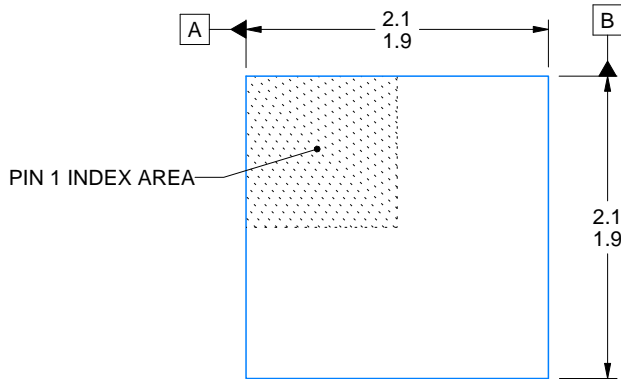

ALTERNATIVE TERMINAL SHAPE TYPICAL

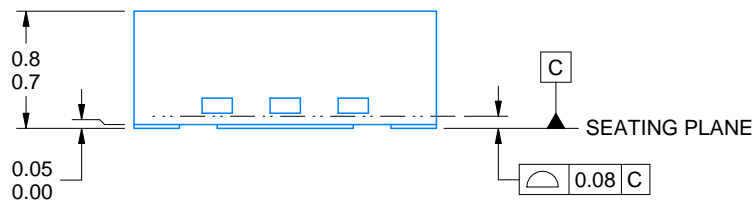

SIDE WALL METAL THICKNESS DIM A	
OPTION 1	OPTION 2
0.1	0.2

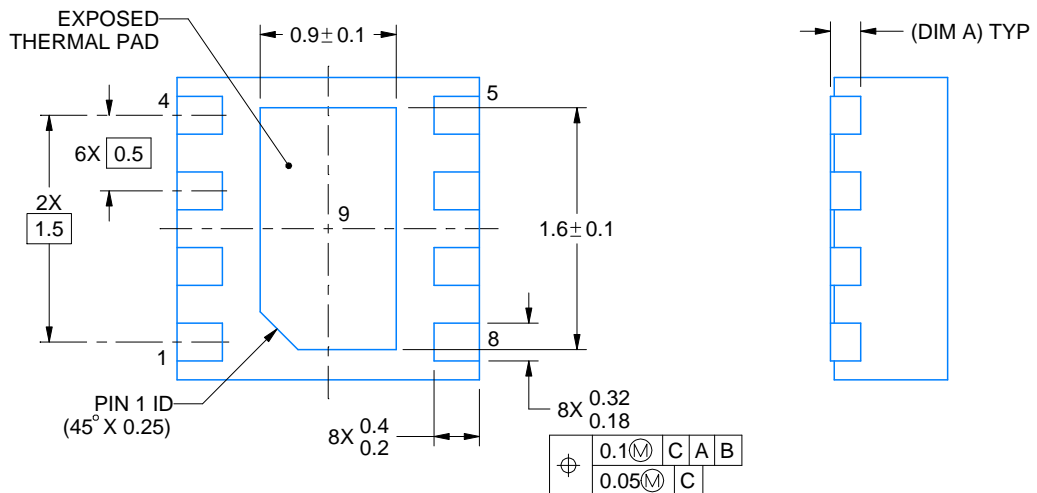

4218900/E 08/2022

NOTES:

1. All linear dimensions are in millimeters. Any dimensions in parenthesis are for reference only. Dimensioning and tolerancing per ASME Y14.5M.
2. This drawing is subject to change without notice.
3. The package thermal pad must be soldered to the printed circuit board for thermal and mechanical performance.

EXAMPLE BOARD LAYOUT

DSG0008A

WSON - 0.8 mm max height

PLASTIC SMALL OUTLINE - NO LEAD

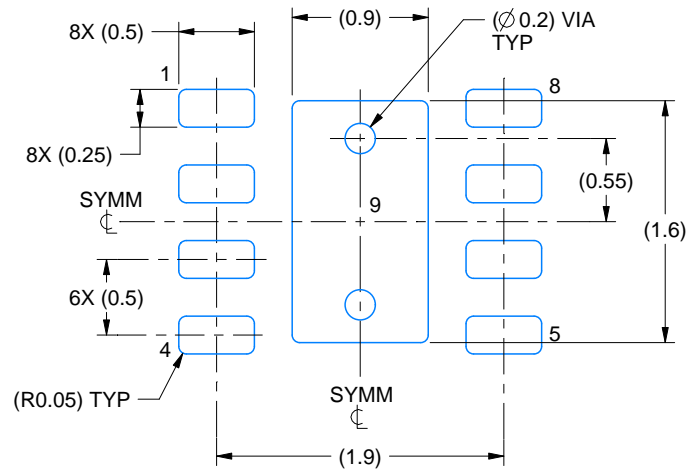

LAND PATTERN EXAMPLE
SCALE:20X

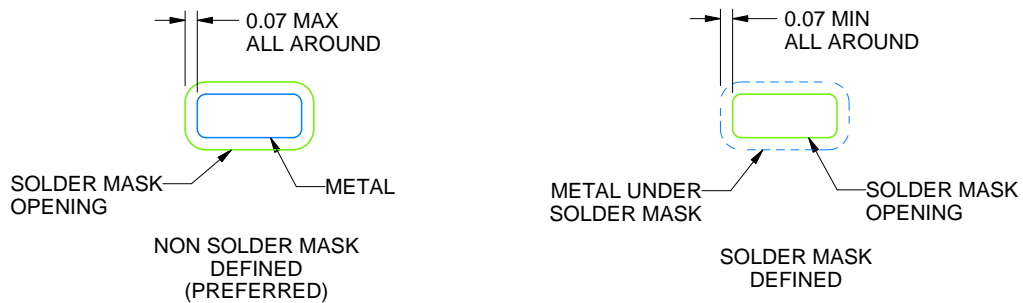

SOLDER MASK DETAILS

4218900/E 08/2022

NOTES: (continued)

4. This package is designed to be soldered to a thermal pad on the board. For more information, see Texas Instruments literature number SLUA271 (www.ti.com/lit/slua271).
5. Vias are optional depending on application, refer to device data sheet. If any vias are implemented, refer to their locations shown on this view. It is recommended that vias under paste be filled, plugged or tented.

EXAMPLE STENCIL DESIGN

DSG0008A

WSON - 0.8 mm max height

PLASTIC SMALL OUTLINE - NO LEAD

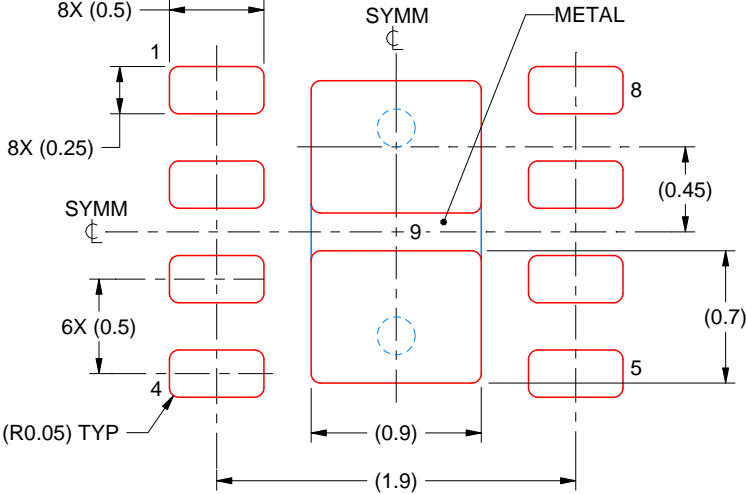

SOLDER PASTE EXAMPLE
BASED ON 0.125 mm THICK STENCIL

EXPOSED PAD 9:
87% PRINTED SOLDER COVERAGE BY AREA UNDER PACKAGE
SCALE:25X

4218900/E 08/2022

NOTES: (continued)

6. Laser cutting apertures with trapezoidal walls and rounded corners may offer better paste release. IPC-7525 may have alternate design recommendations.

重要声明和免责声明

TI“按原样”提供技术和可靠性数据（包括数据表）、设计资源（包括参考设计）、应用或其他设计建议、网络工具、安全信息和其他资源，不保证没有瑕疵且不做任何明示或暗示的担保，包括但不限于对适销性、某特定用途方面的适用性或不侵犯任何第三方知识产权的暗示担保。

这些资源可供使用 TI 产品进行设计的熟练开发人员使用。您将自行承担以下全部责任：(1) 针对您的应用选择合适的 TI 产品，(2) 设计、验证并测试您的应用，(3) 确保您的应用满足相应标准以及任何其他功能安全、信息安全、监管或其他要求。

这些资源如有变更，恕不另行通知。TI 授权您仅可将这些资源用于研发本资源所述的 TI 产品的应用。严禁对这些资源进行其他复制或展示。您无权使用任何其他 TI 知识产权或任何第三方知识产权。您应全额赔偿因在这些资源的使用中对 TI 及其代表造成的任何索赔、损害、成本、损失和债务，TI 对此概不负责。

TI 提供的产品受 [TI 的销售条款](#) 或 [ti.com](#) 上其他适用条款/TI 产品随附的其他适用条款的约束。TI 提供这些资源并不会扩展或以其他方式更改 TI 针对 TI 产品发布的适用的担保或担保免责声明。

TI 反对并拒绝您可能提出的任何其他或不同的条款。

邮寄地址：Texas Instruments, Post Office Box 655303, Dallas, Texas 75265

Copyright © 2024，德州仪器 (TI) 公司