

## DS90UR907Q 5 - 65MHz 24 位彩色平面显示器-链路 (FPD-Link) 至 FPD-Link II 转换器

查询样品: [DS90UR907Q-Q1](#)

### 特性

- 支持 **5 – 65MHz** (**140Mbps** 至 **1.82Gbps** 串行链路)
- **5 通道** (**4 个数据 + 1 个时钟**) **FPD-Link** 接收器输入
- 长度达 **10 米**的 **AC 耦合生成树协议 (STP)** 互连
- 集成型输出端接
- 全速 (**@ Speed**) 链路内置自检 (**BIST**) 模式
- 可选 **I2C** 兼容串行控制总线
- **RGB888 + VS, HS, DE** 支持
- 断电模式大大减少了功率耗散
- 随机发生器/扰频器 - **DC** 均衡数据流
- 低电磁干扰 (**EMI**) **FPD-Link** 输入
- 可选输出视频点播 (**VOD**) 和可调节去加重
- **1.8V** 或 **3.3V** 兼容控制总线接口
- 汽车应用级产品: 符合 **AEC-Q100 2** 级要求
- **>8kV** 人体模型 (**HBM**) 和 **ISO 10605** 静电放电 (**ESD**) 等级
- 向后兼容模式以实现与之前生产的器件的共同运行

### 应用范围

- 汽车导航显示屏
- 汽车娱乐系统显示屏

### 说明

DS90UR907Q 将 FPD-Link 转换为 FPD-Link II。它将 4 个低压差分信令 (LVDS) 数据/控制数据流和 1 个 LVDS 时钟对 (FPD-Link) 转化为一个单对线上的高速串行化接口 (FPD-Link II)。这个串行总线方案消除了时钟和数据间的偏差问题,从而大大简化了系统设计,减少了控制器引脚数量,并且减少了互连线尺寸、重量和成本,并从总体上简化了印刷电路板 (PCB) 布局布线。此外,内部 DC 均衡编码被用来支持 AC 耦合互连。

DS90UR907Q 对 4 个 LVDS 数据/控制数据流进行转换、均衡和电平位移,并且将 1 个 LVDS 时钟对 (FPD-Link) 嵌入进一个串行数据流 (FPD-Link II)。FPD-Link 内高达 24 位的 RGB 连同 3 个视频控制信号被一同串化。

通过一个用户可选去加重和差分输出电平选择特性可优化串行传输。低压差分信令的使用和展频计时兼容性大大减少了 EMI。

由于连接至主机物理接口的接线更少,使用 LVDS 技术的 FPD-Link 输入非常适合于高速、低功率和低 EMI 数据传输。

此器件采用 36 引脚超薄四方扁平无引线封装 (WQFN) 封装,并可在  $-40^{\circ}\text{C}$  至  $+105^{\circ}\text{C}$  的汽车 AEC-Q100 2 级额定温度范围内运行。



Please be aware that an important notice concerning availability, standard warranty, and use in critical applications of Texas Instruments semiconductor products and disclaimers thereto appears at the end of this data sheet.

All trademarks are the property of their respective owners.

PRODUCTION DATA information is current as of publication date. Products conform to specifications per the terms of the Texas Instruments standard warranty. Production processing does not necessarily include testing of all parameters.

Applications Diagram

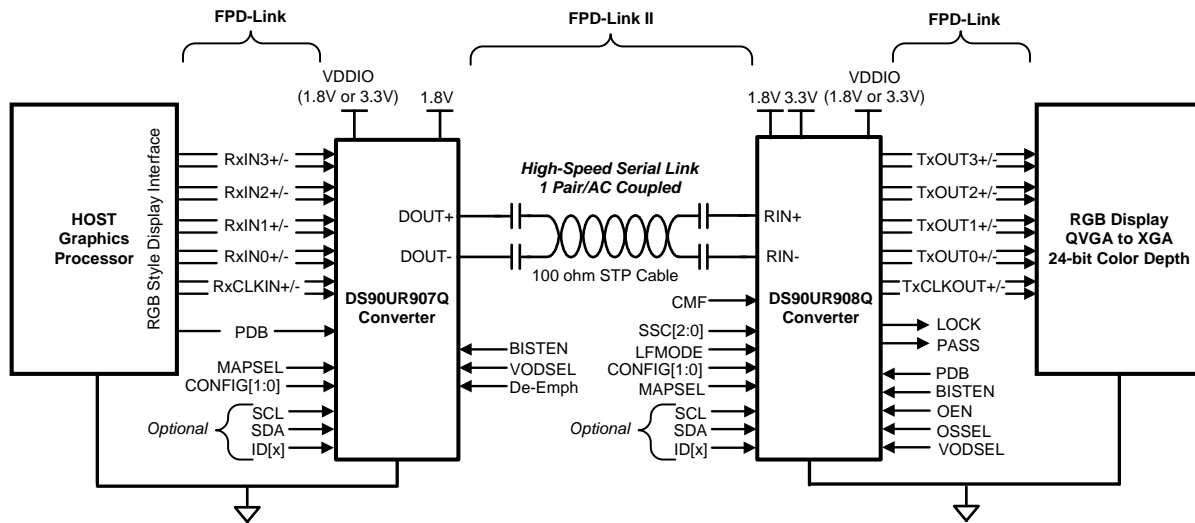

DS90UR907Q Pin Diagram

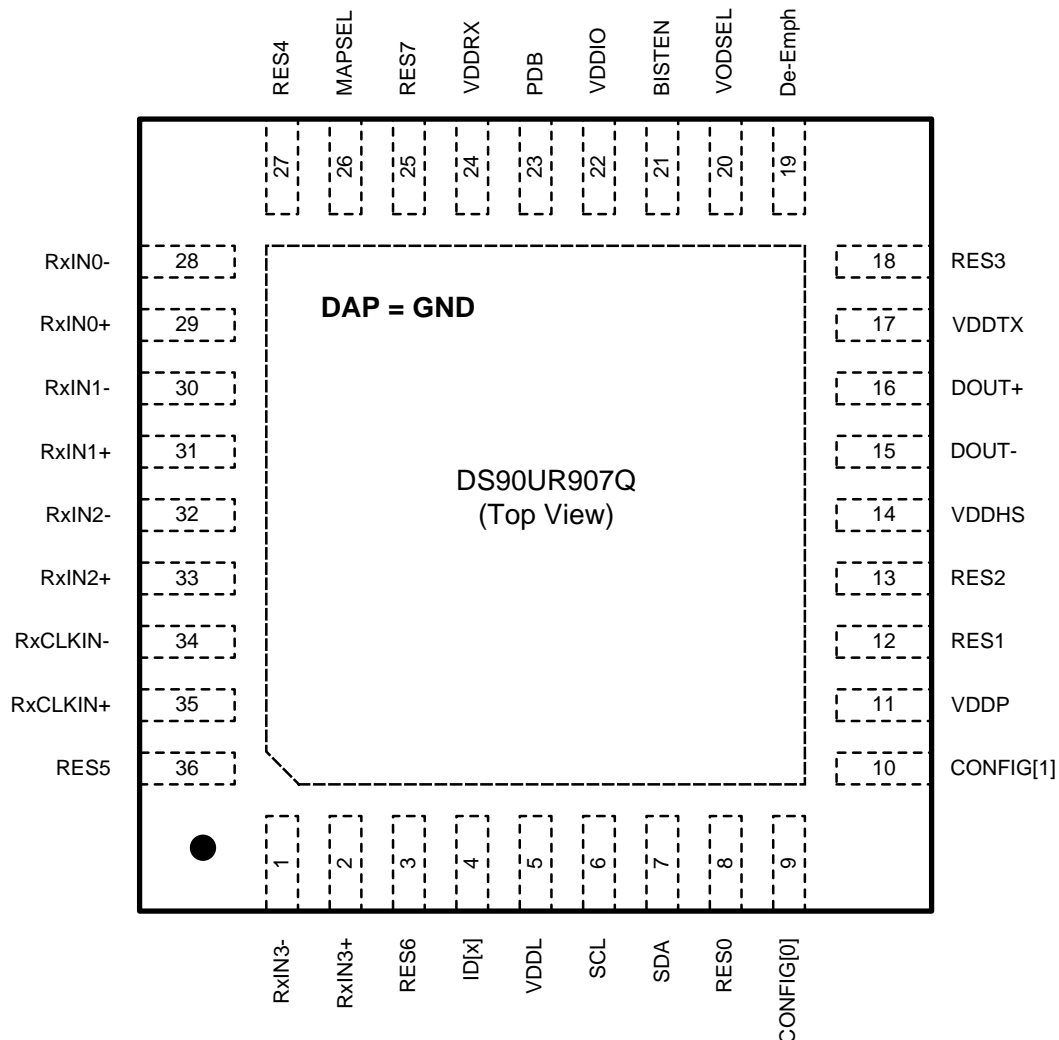

Figure 1. DS90UR907Q — Top View

**PIN DESCRIPTIONS**

Pin Name	Pin #	I/O, Type	Description
<b>FPD-Link Input Interface</b>			
RxIN[3:0]+	2, 33, 31, 29	I, LVDS	True LVDS Data Input This pair requires an external 100 Ω termination for standard LVDS levels.
RxIN[3:0]-	1, 34, 32, 30, 28	I, LVDS	Inverting LVDS Data Input This pair requires an external 100 Ω termination for standard LVDS levels.
RxCLKIN+	35	I, LVDS	True LVDS Clock Input This pair requires an external 100 Ω termination for standard LVDS levels.
RxCLKIN-	34	I, LVDS	Inverting LVDS Clock Input This pair requires an external 100 Ω termination for standard LVDS levels.
<b>Control and Configuration</b>			
PDB	23	I, LVCMOS w/ pull-down	Power-down Mode Input PDB = 1, Device is enabled (normal operation). Refer to " <a href="#">POWER UP REQUIREMENTS AND PDB PIN</a> " in the Applications Information Section. PDB = 0, Device is powered down When the Device is in the power-down state, the driver outputs (DOUT+/-) are both logic high, the PLL is shutdown, IDD is minimized. Control Registers are <b>RESET</b> .
VODSEL	20	I, LVCMOS w/ pull-down	Differential Driver Output Voltage Select — Pin or Register Control VODSEL = 1, LVDS VOD is ±450 mV, 900 mVp-p (typ) — Long Cable / De-E Applications VODSEL = 0, LVDS VOD is ±300 mV, 600 mVp-p (typ)
De-Emph	19	I, Analog w/ pull-up	De-Emphasis Control — Pin or Register Control De-Emph = open (float) - disabled To enable De-emphasis, tie a resistor from this pin to GND or control via register. See <a href="#">Table 3</a>
MAPSEL	26	I, LVCMOS w/ pull-down	FPD-Link Map Select — Pin or Register Control MAPSEL = 1, MSB on RxIN3+/- . <a href="#">Figure 18</a> MAPSEL = 0, LSB on RxIN3+/- . <a href="#">Figure 17</a>
CONFIG[1:0]	10, 9	I, LVCMOS w/ pull-down	Operating Modes Determine the device operating mode and interfacing device. <a href="#">Table 1</a> CONFIG[1:0] = 00: Interfacing to DS90UR906 or DS90UR908, Control Signal Filter DISABLED CONFIG[1:0] = 01: Interfacing to DS90UR906 or DS90UR908, Control Signal Filter ENABLED CONFIG [1:0] = 10: Interfacing to DS90UR124, DS99R124 CONFIG [1:0] = 11: Interfacing to DS90C124
ID[x]	4	I, Analog	Serial Control Bus Device ID Address Select — Optional Resistor to Ground and 10 kΩ pull-up to 1.8V rail. See <a href="#">Table 4</a> .
SCL	6	I, LVCMOS	Serial Control Bus Clock Input - Optional SCL requires an external pull-up resistor to V <sub>DDIO</sub> .
SDA	7	I/O, LVCMOS Open Drain	Serial Control Bus Data Input / Output - Optional SDA requires an external pull-up resistor V <sub>DDIO</sub> .
BISTEN	21	I, LVCMOS w/ pull-down	BIST Mode — Optional BISTEN = 1, BIST is enabled BISTEN = 0, BIST is disabled
RES[7:0]	25, 3, 36, 27, 18, 13, 12, 8	I, LVCMOS w/ pull-down	<b>Reserved</b> - tie LOW
<b>FPD-Link II Serial Interface</b>			
DOUT+	16	O, LVDS	True Output. The output must be AC Coupled with a 100 nF capacitor.
DOUT-	15	O, LVDS	Inverting Output. The output must be AC Coupled with a 100 nF capacitor.

**PIN DESCRIPTIONS (continued)**

Pin Name	Pin #	I/O, Type	Description
<b>Power and Ground</b>			
VDDL	5	Power	Logic Power, 1.8 V $\pm$ 5%
VDDP	11	Power	PLL Power, 1.8 V $\pm$ 5%
VDDHS	14	Power	TX High Speed Logic Power, 1.8 V $\pm$ 5%
VDDTX	17	Power	Output Driver Power, 1.8 V $\pm$ 5%
VDDR <sub>X</sub>	24	Power	RX Power, 1.8 V $\pm$ 5%
V <sub>DDIO</sub>	22	Power	LVC MOS I/O Power and FPD-Link I/O Power 1.8 V $\pm$ 5% OR 3.3 V $\pm$ 10%
GND	DAP	Ground	DAP is the large metal contact at the bottom side, located at the center of the WQFN package. <b>Connect to the ground plane (GND)</b> with at least 9 vias.

**Note:** 1 = HIGH, 0 = LOW

The VDD (V<sub>DDn</sub> and V<sub>DDIO</sub>) supply ramp should be faster than 1.5 ms with a monotonic rise.

**Block Diagram**

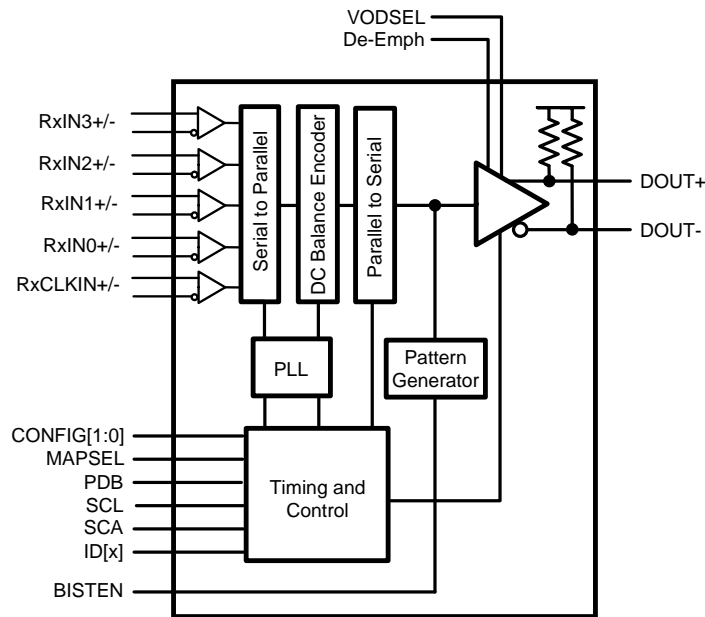

**FDP-Link to FPD-Link II Converter**



These devices have limited built-in ESD protection. The leads should be shorted together or the device placed in conductive foam during storage or handling to prevent electrostatic damage to the MOS gates.

### Absolute Maximum Ratings<sup>(1)(2)</sup>

Supply Voltage – $V_{DDn}$ (1.8V)	-0.3V to +2.5V
Supply Voltage – $V_{DDIO}$	-0.3V to +4.0V
LVCMOS I/O Voltage	-0.3V to ( $V_{DDIO} + 0.3V$ )
LVDS Input Voltage	-0.3V to ( $V_{DDIO} + 0.3V$ )
Driver Output Voltage	-0.3V to ( $V_{DDn} + 0.3V$ )
Junction Temperature	+150°C
Storage Temperature	-65°C to +150°C
36L WQFN Package	
Maximum Power Dissipation Capacity at 25°C	
Derate above 25°C	1/ $\theta_{JA}$ °C/W
$\theta_{JA}$	27.4 °C/W
$\theta_{JC}$	4.5 °C/W
ESD Rating (IEC, powered-up only), $R_D = 330\Omega$ , $C_S = 150pF$	
Air Discharge ( $R_{IN+}$ , $R_{IN-}$ )	$\geq \pm 30$ kV
Contact Discharge ( $R_{IN+}$ , $R_{IN-}$ )	$\geq \pm 6$ kV
ESD Rating (ISO10605), $R_D = 330\Omega$ , $C_S = 150$ & $330pF$	
Air Discharge ( $R_{IN+}$ , $R_{IN-}$ )	$\geq \pm 15$ kV
Contact Discharge ( $R_{IN+}$ , $R_{IN-}$ )	$\geq \pm 8$ kV
ESD Rating (ISO10605), $R_D = 2k\Omega$ , $C_S = 150$ & $330pF$	
Air Discharge ( $R_{IN+}$ , $R_{IN-}$ )	$\geq \pm 15$ kV
Contact Discharge ( $R_{IN+}$ , $R_{IN-}$ )	$\geq \pm 8$ kV
ESD Rating (HBM)	$\geq \pm 8$ kV
ESD Rating (CDM)	$\geq \pm 1.25$ kV
ESD Rating (MM)	$\geq \pm 250$ V

- (1) "Absolute Maximum Ratings" indicate limits beyond which damage to the device may occur, including inoperability and degradation of device reliability and/or performance. Functional operation of the device and/or non-degradation at the Absolute Maximum Ratings or other conditions beyond those indicated in the Recommended Operating Conditions is not implied. The Recommended Operating Conditions indicate conditions at which the device is functional and the device should not be operated beyond such conditions.
- (2) If Military/Aerospace specified devices are required, please contact the Texas Instruments Sales Office/ Distributors for availability and specifications.

### Recommended Operating Conditions

	Min	Nom	Max	Units
Supply Voltage ( $V_{DDn}$ )	1.71	1.8	1.89	V
LVCMOS Supply Voltage ( $V_{DDIO}$ )	1.71	1.8	1.89	V
<b>OR</b>				
LVCMOS Supply Voltage ( $V_{DDIO}$ )	3.0	3.3	3.6	V
Operating Free Air Temperature ( $T_A$ )	-40	+25	+105	°C
RxCLKIN Frequency	5		65	MHz
Supply Noise <sup>(1)</sup>			100	mV <sub>P-P</sub>

- (1) Supply noise testing was done with minimum capacitors on the PCB. A sinusoidal signal is AC coupled to the  $V_{DDn}$  (1.8V) supply with amplitude = 100 mVp-p measured at the device  $V_{DDn}$  pins. Bit error rate testing of input to the Ser and output of the Des with 10 meter cable shows no error when the noise frequency on the Ser is less than 750 kHz. The Des on the other hand shows no error when the noise frequency is less than 400 kHz.

## DC Electrical Characteristics

Over recommended operating supply and temperature ranges unless otherwise specified. <sup>(1)</sup><sup>(2)</sup><sup>(3)</sup>

Symbol	Parameter	Conditions	Pin/Freq.	Min	Typ	Max	Units	
<b>LVC MOS INPUT DC SPECIFICATIONS</b>								
V <sub>IH</sub>	High Level Input Voltage	V <sub>DDIO</sub> = 3.0 to 3.6V	PDB, VODSEL, MAPSEL, CONFIG[1:0], BISTEN	2.2		V <sub>DDIO</sub>	V	
		V <sub>DDIO</sub> = 1.71 to 1.89V		0.65* V <sub>DDIO</sub>		V <sub>DDIO</sub>	V	
V <sub>IL</sub>	Low Level Input Voltage	V <sub>DDIO</sub> = 3.0 to 3.6V		GND		0.8		V
		V <sub>DDIO</sub> = 1.71 to 1.89V		GND		0.35* V <sub>DDIO</sub>		V
I <sub>IN</sub>	Input Current	V <sub>IN</sub> = 0V or V <sub>DDIO</sub>		V <sub>DDIO</sub> = 3.0 to 3.6V	-15	±1	+15	µA
				V <sub>DDIO</sub> = 1.7 to 1.89V	-15	±1	+15	µA
<b>FPD-LINK LVDS RECEIVER DC SPECIFICATIONS</b>								
V <sub>TH</sub>	Differential Threshold High Voltage	V <sub>CM</sub> = 1.2V, <a href="#">Figure 2</a>	RxIN[3:0]+/-, RxCLKIN+/-,			+100	mV	
V <sub>TL</sub>	Differential Threshold Low Voltage			-100				
V <sub>ID</sub>	Differential Input Voltage Swing			200		600	mV	
V <sub>CM</sub>	Common Mode Voltage			V <sub>DDIO</sub> = 3.3V		0	1.2	2.4
		V <sub>DDIO</sub> = 1.8V		0	1.2	1.55		
I <sub>IN</sub>	Input Current			-15	±1	+15	µA	
<b>FPD-LINK II LVDS DRIVER DC SPECIFICATIONS</b>								
V <sub>OD</sub>	Differential Output Voltage	R <sub>L</sub> = 100Ω, De-emph = disabled, <a href="#">Figure 4</a>	DOUT+, DOUT-	VODSEL = 0	±225	±300	±375	mV
				VODSEL = 1	±350	±450	±550	
V <sub>ODp-p</sub>	Differential Output Voltage (DOUT+) – (DOUT-)			VODSEL = 0		600		mVp-p
				VODSEL = 1		900		mVp-p
ΔV <sub>OD</sub>	Output Voltage Unbalance	R <sub>L</sub> = 100Ω, De-emph = disabled, VODSEL = L				1	50	mV
V <sub>OS</sub>	Offset Voltage – Single-ended At TP A & B, <a href="#">Figure 3</a>	R <sub>L</sub> = 100Ω, De-emph = disabled		VODSEL = 0		1.65		V
				VODSEL = 1		1.575		V
ΔV <sub>OS</sub>	Offset Voltage Unbalance Single-ended At TP A & B, <a href="#">Figure 3</a>	R <sub>L</sub> = 100Ω, De-emph = disabled				1		mV
I <sub>OS</sub>	Output Short Circuit Current	DOUT+/- = 0V, De-emph = disabled	VODSEL = 0		-35		mA	
R <sub>T</sub>	Internal Termination Resistor			80		120	Ω	

- The Electrical Characteristics tables list ensured specifications under the listed Recommended Operating Conditions except as otherwise modified or specified by the Electrical Characteristics Conditions and/or Notes. Typical specifications are estimations only and are not ensured.
- Typical values represent most likely parametric norms at V<sub>DD</sub> = 3.3V, T<sub>a</sub> = +25 degC, and at the Recommended Operation Conditions at the time of product characterization and are not ensured.
- Current into device pins is defined as positive. Current out of a device pin is defined as negative. Voltages are referenced to ground except V<sub>OD</sub>, ΔV<sub>OD</sub>, V<sub>TH</sub> and V<sub>TL</sub> which are differential voltages.

## DC Electrical Characteristics (continued)

 Over recommended operating supply and temperature ranges unless otherwise specified.<sup>(1)(2)(3)</sup>

Symbol	Parameter	Conditions	Pin/Freq.	Min	Typ	Max	Units		
<b>SUPPLY CURRENT</b>									
$I_{DDT1}$	Supply Current (includes load current) $R_L = 100\Omega$ , $f = 65\text{MHz}$	Checker Board Pattern, De-emph = 3 k $\Omega$ , VODSEL = H, Figure 11	$V_{DD} = 1.89\text{V}$	All $V_{DD}$ pins		80	90	mA	
$I_{DDIOT1}$			$V_{DDIO} = 1.89\text{V}$		$V_{DDIO}$		3	5	mA
			$V_{DDIO} = 3.6\text{V}$				10	13	mA
$I_{DDT2}$		Checker Board Pattern, De-emph = 6 k $\Omega$ , VODSEL = L, Figure 11	$V_{DD} = 1.89\text{V}$	All $V_{DD}$ pins		75	85	mA	
$I_{DDIOT2}$			$V_{DDIO} = 1.89\text{V}$		$V_{DDIO}$		3	5	mA
			$V_{DDIO} = 3.6\text{V}$				10	13	mA
$I_{DDZ}$	Supply Current Power-down	PDB = 0V, (All other LVCMOS Inputs = 0V)	$V_{DD} = 1.89\text{V}$	All $V_{DD}$ pins		60	1000	$\mu\text{A}$	
$I_{DDIOZ}$			$V_{DDIO} = 1.89\text{V}$		$V_{DDIO}$		0.5	10	$\mu\text{A}$
			$V_{DDIO} = 3.6\text{V}$				1	30	$\mu\text{A}$

## Switching Characteristics

Over recommended operating supply and temperature ranges unless otherwise specified.

Symbol	Parameter	Conditions	Min	Typ	Max	Units
<b>FPD-LINK LVDS INPUT</b>						
$t_{RSP0}$	Receiver Strobe Position-bit 0	$RxCLKIN = 65\text{MHz}$ , $RxIN[3:0]$ Figure 6	0.66	1.10	1.54	ns
$t_{RSP1}$	Receiver Strobe Position-bit 1		2.86	3.30	3.74	ns
$t_{RSP2}$	Receiver Strobe Position-bit 2		5.05	5.50	5.93	ns
$t_{RSP3}$	Receiver Strobe Position-bit 3		7.25	7.70	8.13	ns
$t_{RSP4}$	Receiver Strobe Position-bit 4		9.45	9.90	10.33	ns
$t_{RSP5}$	Receiver Strobe Position-bit 5		11.65	12.10	12.53	ns
$t_{RSP6}$	Receiver Strobe Position-bit 6		13.85	14.30	14.73	ns
<b>FPD-LINK II LVDS OUTPUT</b>						
$t_{HLT}$	Output Low-to-High Transition Time, Figure 5	$R_L = 100\Omega$ , De-emphasis = disabled, VODSEL = 0		200		ps
		$R_L = 100\Omega$ , De-emphasis = disabled, VODSEL = 1		200		ps
$t_{HLT}$	Output High-to-Low Transition Time, Figure 5	$R_L = 100\Omega$ , De-emphasis = disabled, VODSEL = 0		200		ps
		$R_L = 100\Omega$ , De-emphasis = disabled, VODSEL = 1		200		ps
$t_{XZD}$	Output Active to OFF Delay, Figure 8			5	15	ns
$t_{PLD}$	PLL Lock Time, Figure 7	$R_L = 100\Omega$ <sup>(1)</sup>		1.5	10	ms
$t_{SD}$	Delay - Latency, Figure 9	$R_L = 100\Omega$		140*T	145*T	ns
$t_{DJIT}$	Output Total Jitter, Figure 10	$R_L = 100\Omega$ , De-Emph = disabled, RANDOM pattern, $RxCLKIN = 43 \& 65\text{MHz}$ <sup>(2)</sup>		0.26		UI
$\lambda_{STXBW}$	Jitter Transfer Function -3 dB Bandwidth <sup>(3) (4)</sup>	$RxCLKIN = 43\text{MHz}$		2.2		MHz
		$RxCLKIN = 65\text{MHz}$		3		
$\bar{\sigma}_{STX}$	Jitter Transfer Function Peaking <sup>(3)(4)</sup>	$RxCLKIN = 43\text{MHz}$		1		dB
		$RxCLKIN = 65\text{MHz}$		1		

 (1)  $t_{PLD}$  is the time required by the device to obtain lock when exiting power-down state with an active  $RxCLKIN$ .

 (2) UI – Unit Interval is equivalent to one serialized data bit width ( $1UI = 1 / 28 * RxCLKIN$ ). The UI scales with  $RxCLKIN$  frequency.

(3) Specification is ensured by characterization and is not tested in production.

(4) Specification is ensured by design and is not tested in production.

## Recommended Timing for the Serial Control Bus

Over 3.3V supply and temperature ranges unless otherwise specified.

Symbol	Parameter	Conditions	Min	Typ	Max	Units
f <sub>SCL</sub>	SCL Clock Frequency	Standard Mode	0		100	kHz
		Fast Mode	0		400	kHz
t <sub>LOW</sub>	SCL Low Period	Standard Mode	4.7			us
		Fast Mode	1.3			us
t <sub>HIGH</sub>	SCL High Period	Standard Mode	4.0			us
		Fast Mode	0.6			us
t <sub>HD;STA</sub>	Hold time for a start or a repeated start condition, <a href="#">Figure 13</a>	Standard Mode	4.0			us
		Fast Mode	0.6			us
t <sub>SU;STA</sub>	Set Up time for a start or a repeated start condition, <a href="#">Figure 13</a>	Standard Mode	4.7			us
		Fast Mode	0.6			us
t <sub>HD;DAT</sub>	Data Hold Time, <a href="#">Figure 13</a>	Standard Mode	0		3.45	us
		Fast Mode	0		0.9	us
t <sub>SU;DAT</sub>	Data Set Up Time, <a href="#">Figure 13</a>	Standard Mode	250			ns
		Fast Mode	100			ns
t <sub>SU;STO</sub>	Set Up Time for STOP Condition, <a href="#">Figure 13</a>	Standard Mode	4.0			us
		Fast Mode	0.6			us
t <sub>BUF</sub>	Bus Free Time Between STOP and START, <a href="#">Figure 13</a>	Standard Mode	4.7			us
		Fast Mode	1.3			us
t <sub>r</sub>	SCL & SDA Rise Time, <a href="#">Figure 13</a>	Standard Mode			1000	ns
		Fast Mode			300	ns
t <sub>f</sub>	SCL & SDA Fall Time, <a href="#">Figure 13</a>	Standard Mode			300	ns
		Fast mode			300	ns

## DC and AC Serial Control Bus Characteristics

Over 3.3V supply and temperature ranges unless otherwise specified.

Symbol	Parameter	Conditions	Min	Typ	Max	Units
V <sub>IH</sub>	Input High Level	SDA and SCL	0.7* V <sub>DDIO</sub>		V <sub>DDIO</sub>	V
V <sub>IL</sub>	Input Low Level Voltage	SDA and SCL	GND		0.3* V <sub>DDIO</sub>	V
V <sub>HY</sub>	Input Hysteresis			>50		mV
V <sub>OL</sub>		SDA, IOL = 1.25mA	0		0.36	V
I <sub>in</sub>		SDA or SCL, Vin = V <sub>DDIO</sub> or GND	-10		+10	μA
t <sub>R</sub>	SDA RiseTime – READ	SDA, RPU = 10kΩ, Cb ≤ 400pF, <a href="#">Figure 13</a>		430		ns
t <sub>F</sub>	SDA Fall Time – READ			20		ns
t <sub>SU;DAT</sub>	Set Up Time — READ	See <a href="#">Figure 13</a>		560		ns
t <sub>HD;DAT</sub>	Hold Up Time — READ	See <a href="#">Figure 13</a>		615		ns
t <sub>SP</sub>	Input Filter			50		ns
C <sub>in</sub>	Input Capacitance	SDA or SCL		<5		pF



AC Timing Diagrams and Test Circuits

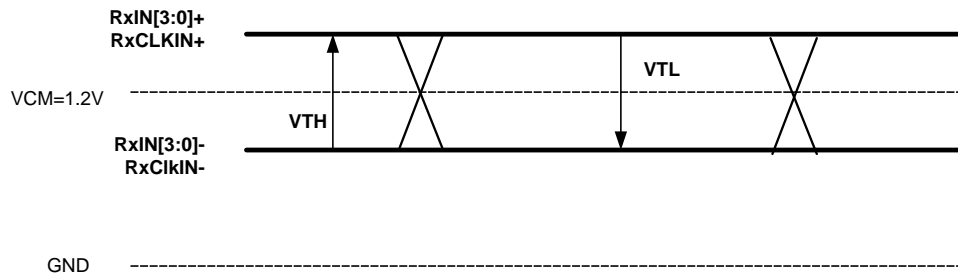

Figure 2. FPD-Link DC VTH/VTL Definition

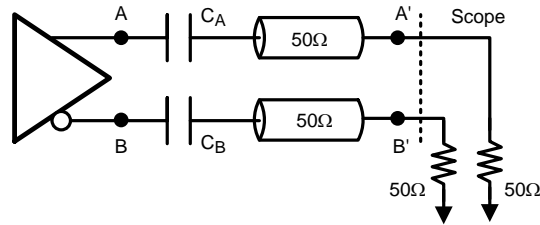

Figure 3. Output Test Circuit

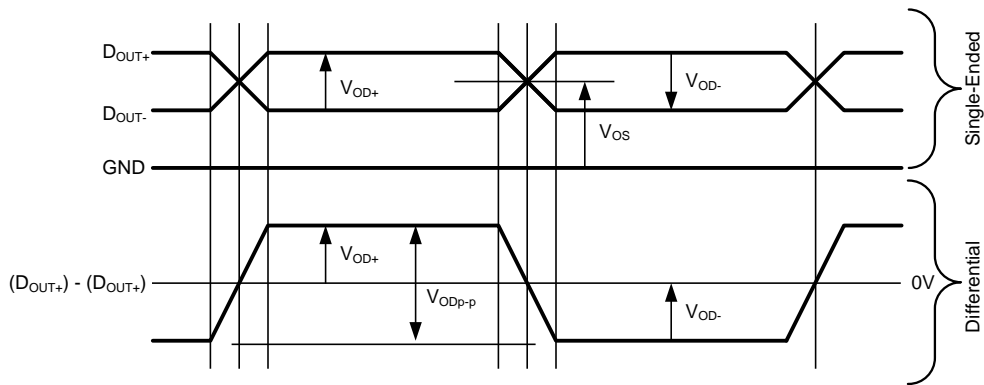

Figure 4. Output Waveforms

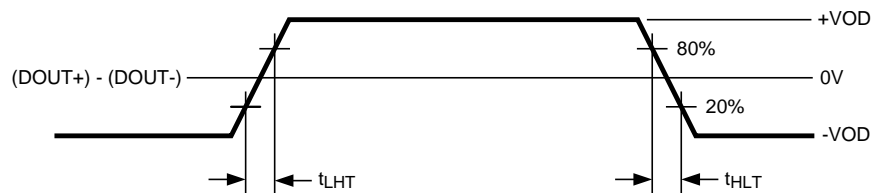

Figure 5. Output Transition Times

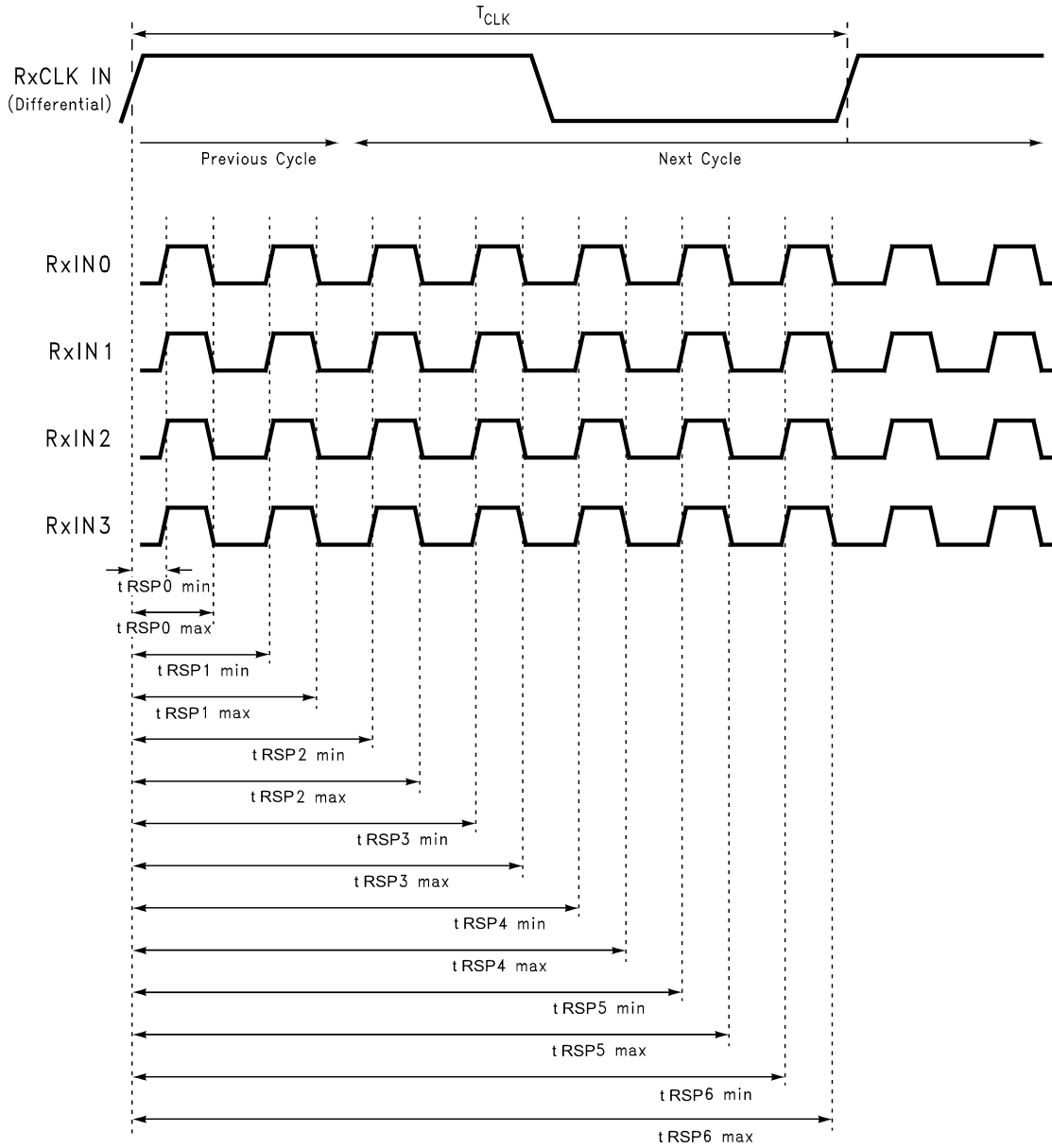

Figure 6. FPD-Link Input Jitter Tolerance

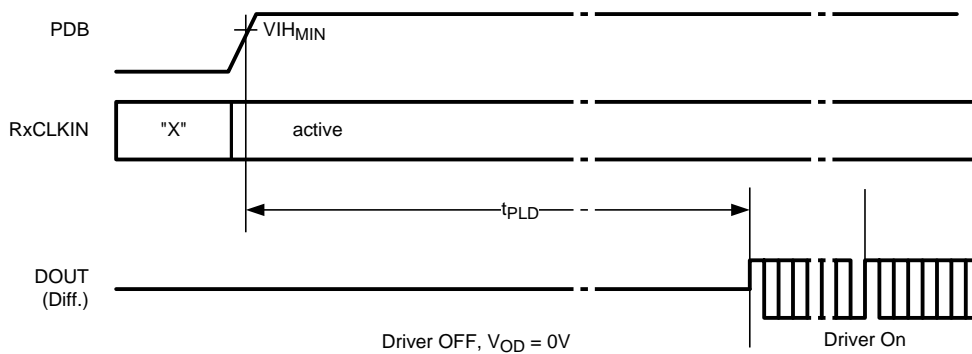

Figure 7. Lock Time

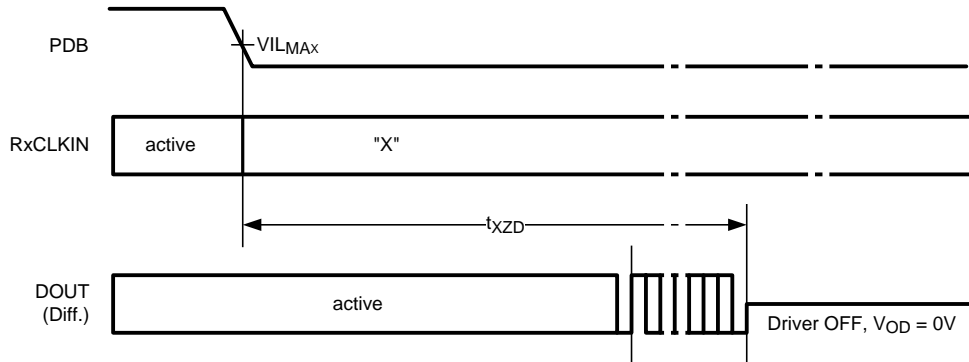

Figure 8. Disable Time

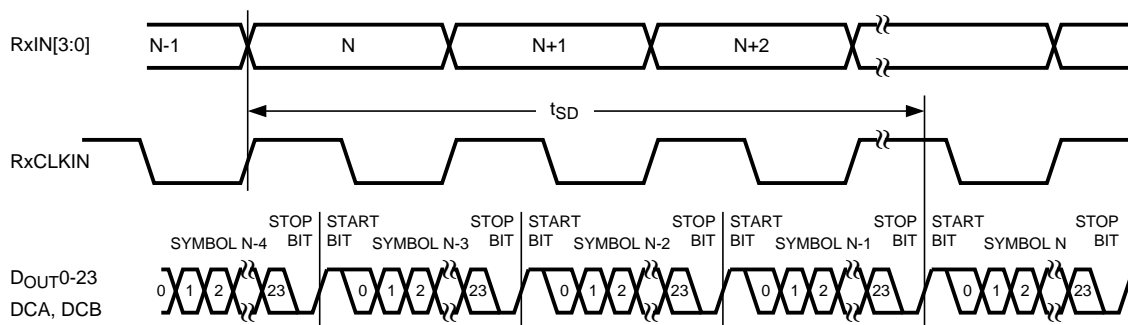

Figure 9. Latency Delay

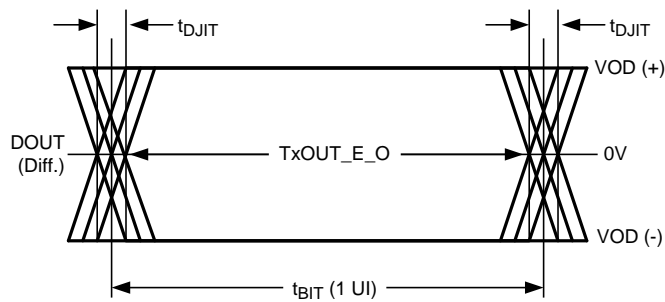

Figure 10. Output Jitter

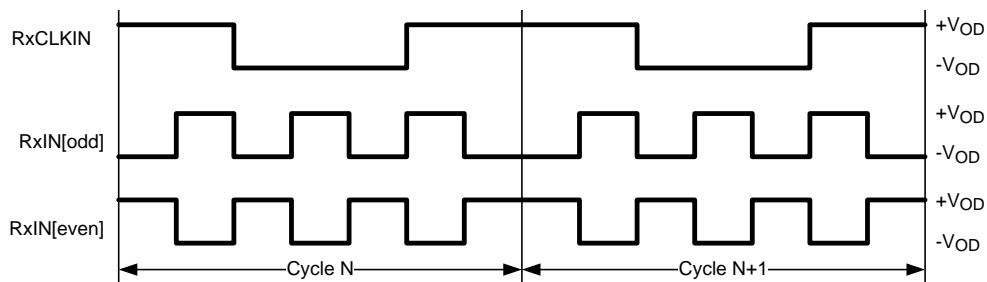

Figure 11. Checkerboard Data Pattern

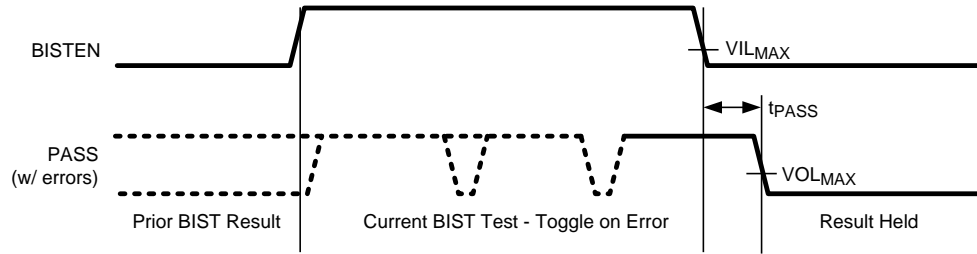

Figure 12. BIST PASS Waveform

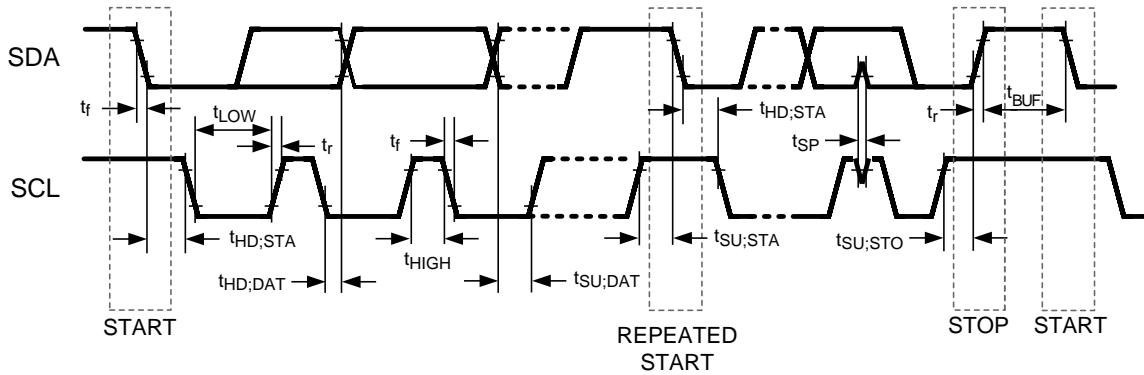

Figure 13. Serial Control Bus Timing Diagram

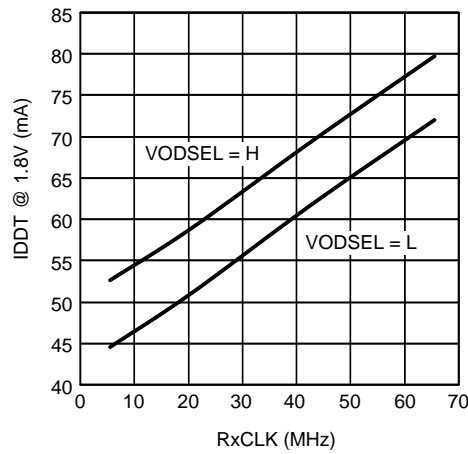

Figure 14. Typical IDDT (1.8V Supply) Current as a function of RxCLK

## Functional Description

The DS90UR907Q converter transmits an FPD-Link interface (4 LVDS data channels + 1 LVDS clock) with total of 27-bits of data (24-high speed bits and 3 low speed video control signals) over a single serial FPD-Link II pair. The serial stream also contains an embedded clock and the DC-balance information which enhances signal quality and supports AC coupling. The device is intended for use with DS90UR908Q or DS90UR906Q, but is backward compatible with previous generations of FPD-Link II as well.

The DS90UR907Q can operate in 24-bit color mode(with VS,HS,DE encoded in the serial stream) or in 18-bit color mode.

The DS90UR907Q can be configured via external pins or through the optional serial control bus. It features enhance signal quality on the link by supporting: selectable VOD level, selectable de-emphasis signal conditioning and also the FPD-Link II data coding that provides randomization, scrambling, and DC Balancing of the video data. It also includes multiple features to reduce EMI associated with display data transmission. This includes the randomization and scrambling of the data and also the system spread spectrum PCLK support. The DS90UR907Q features power saving with a powerdown mode, and auto stop clock feature.

See also the Functional Description of the serial control bus and BIST modes.

The [Block Diagram](#) is shown at the beginning of this datasheet.

## DATA TRANSFER

The DS90UR907Q transmits a pixel of data in the following format: C1 and C0 represent the embedded clock in the serial stream. C1 is always HIGH and C0 is always LOW. b[23:0] contain the scrambled RGB data. DCB is the DC-Balanced control bit. DCB is used to minimize the short and long-term DC bias on the signal lines. This bit determines if the data is unmodified or inverted. DCA is used to validate data integrity in the embedded data stream and can also contain encoded control (VS,HS,DE). Both DCA and DCB coding schemes are generated by the DS90UR907Q and decoded by the paring deserializer automatically. [Figure 15](#) illustrates the serial stream per PCLK cycle.

*Note: The figure only illustrates the bits but does not actually represent the bit location as the bits are scrambled and balanced continuously.*

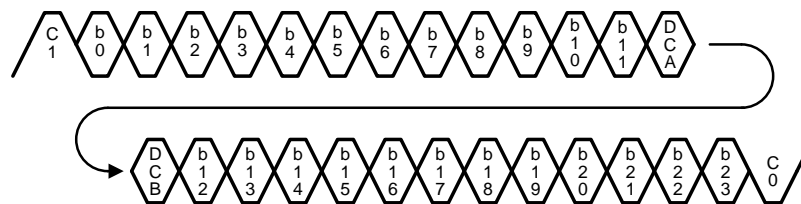

Figure 15. FPD-Link II Serial Stream

## OPERATING MODES AND BACKWARD COMPATIBILITY (CONFIG[1:0])

The DS90UR907Q is backward compatible with previous generations of FPD-Link II deserializers. Configuration modes are provided for backwards compatibility with the DS90C124 FPD-Link II Generation 1, and also the DS90UR124 FPD-Link II Generation 2 deserializers by setting the respective mode with the CONFIG[1:0] pins as shown in [Table 1](#). The selection also determine whether the Video Control Signal filter feature is enabled or disabled in Normal mode.

Table 1. DS90UR907Q Configuration Modes

CON FIG1	CON FIG0	Mode	Des Device
L	L	Normal Mode, Control Signal Filter disabled	DS90UR908Q, DS90UR906Q
L	H	Normal Mode, Control Signal Filter enabled	DS90UR908Q, DS90UR906Q
H	L	Backwards Compatible GEN2	DS90UR124, DS99R124
H	H	Backwards Compatible GEN1	DS90C124

**VIDEO CONTROL SIGNAL FILTER**

When operating the devices in Normal Mode, the Video Control Signals (DE, HS, VS) have the following restrictions:

- Normal Mode with Control Signal Filter Enabled:
  - DE and HS — Only 2 transitions per 130 clock cycles are transmitted, the transition pulse must be 3 PCLK or longer.
- Normal Mode with Control Signal Filter Disabled:
  - DE and HS — Only 2 transitions per 130 clock cycles are transmitted, no restriction on minimum transition pulse.
- VS — Only 1 transition per 130 clock cycles are transmitted, minimum pulse width is 130 clock cycles.

Video Control Signals are defined as low frequency signals with limited transitions. Glitches of a control signal can cause a visual display error. This feature allows for the chipset to validate and filter out any high frequency noise on the control signals. See [Figure 16](#).

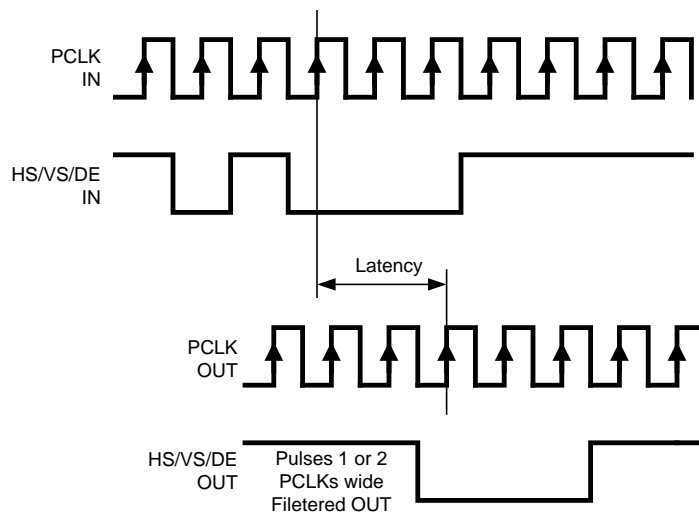

**Figure 16. Video Control Signal Filter Waveform**

**COLOR BIT MAPPING SELECT**

The DS90UR907Q can be configured to accept 24-bit color (8-bit RGB) with 2 different mapping schemes: LSBs on RxIN[3] shown in [Figure 17](#) or MSBs on RxIN[3] shown in [Figure 18](#). The mapping scheme is controlled by MAPSEL pin or by Register.

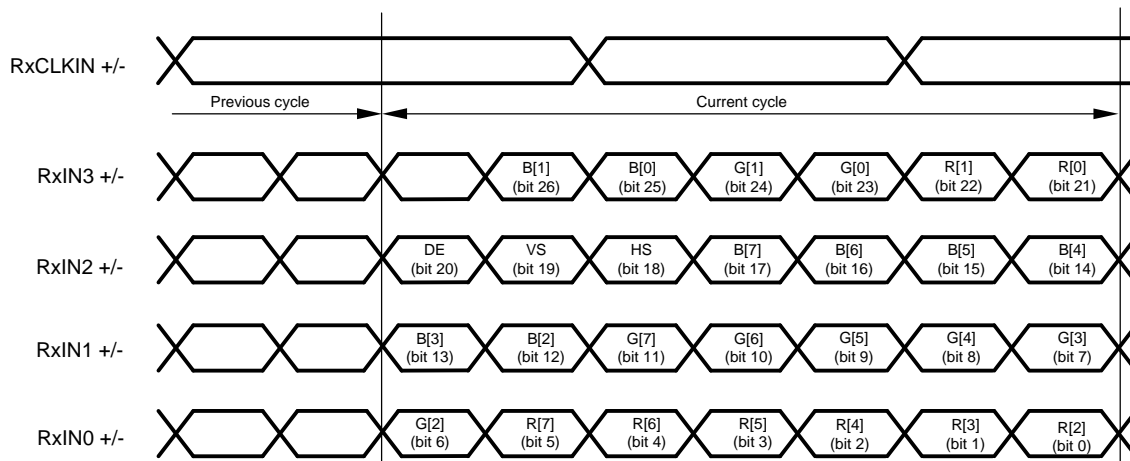

**Figure 17. 8-bit FPD-Link Mapping: LSB's on RxIN3**

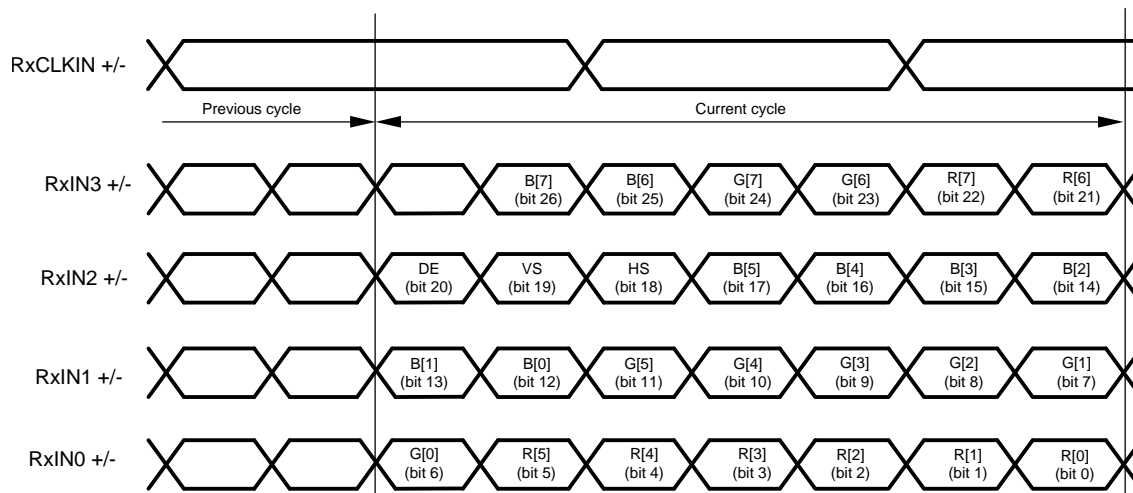

Figure 18. 8-bit FPD-Link Mapping: MSB's on RxIN3

## EMI REDUCTION FEATURES

### Spread Spectrum Compatibility

The RxCLKIN of the FPD-Link input is capable of tracking spread spectrum clocking (SSC) from a host source. The RxCLKIN will accept spread spectrum, tracking up to 35kHz modulation and  $\pm 0.5$ ,  $\pm 1$  or  $\pm 2\%$  deviations (center spread). The maximum conditions for the RxCLKIN input are: a modulation frequency of 35kHz and amplitude deviations of  $\pm 2\%$  (4% total).

## SIGNAL QUALITY ENHANCERS

### VOD Select (VODSEL)

The DS90UR907Q differential output voltage may be increased by setting the VODSEL pin High. When VODSEL is Low, the DC VOD is at the standard (default) level. When VODSEL is High, the DC VOD is increased in level. The increased VOD is useful in extremely high noise environments and also on extra long cable length applications. When using de-emphasis it is recommended to set VODSEL = H to avoid excessive signal attenuation especially with the larger de-emphasis settings. This feature may be controlled by the external pin or by register.

Table 2. Differential Output Voltage

Input	Effect	
	VOD (mV)	VOD (mVp-p)
H	$\pm 450$	900
L	$\pm 300$	600

### De-Emphasis (De-Emph)

The De-Emph pin controls the amount of de-emphasis beginning one full bit time after a logic transition that the device drives. It is the signal conditioning function for use in compensating against cable transmission loss. This pin should be left open for standard switching currents (no de-emphasis) or if controlled by register. De-emphasis is selected by connecting a resistor on this pin to ground, with R value between 0.5 k $\Omega$  to 1 M $\Omega$ , or by register setting. When using De-Emphasis it is recommended to set VODSEL = H.

**Table 3. De-Emphasis Resistor Value**

Resistor Value (k $\Omega$ )	De-Emphasis Setting
Open	Disabled
0.6	- 12 dB
1.0	- 9 dB
2.0	- 6 dB
5.0	- 3 dB

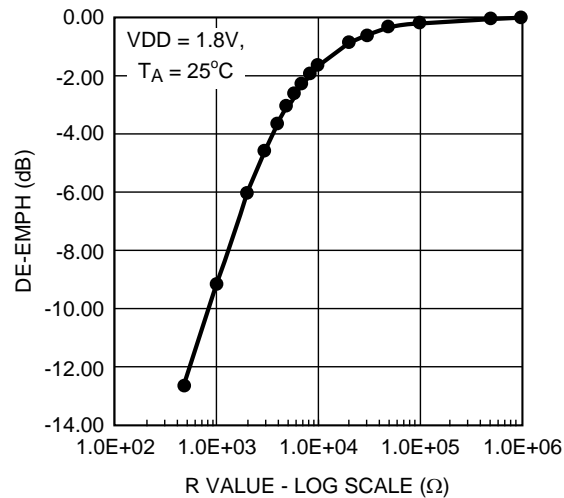
**Figure 19. De-Emph vs. R value**

## POWER SAVING FEATURES

### *Power Down Feature (PDB)*

The DS90UR907Q has a PDB input pin to ENABLE or POWER DOWN the device. This pin is controlled by the host and is used to save power, disabling the link when the display is not needed. In the POWER DOWN mode, the high-speed driver outputs are both pulled to VDD and present a 0V VOD state. Note – in POWER DOWN, the optional Serial Bus Control Registers are **RESET**.

### *Stop Clock Feature*

The DS90UR907Q will enter a low power SLEEP state when the RxCLKIN is stopped. A STOP condition is detected when the input clock frequency is less than 3 MHz. The clock should be held at a static Low or high state. When the RxCLKIN starts again, the device will then lock to the valid input RxCLKIN and then transmits the RGB data to the deserializer. Note – in STOP CLOCK SLEEP, the optional Serial Bus Control Registers values are **RETAINED**.

### *1.8V or 3.3V VDDIO Operation*

The DS90UR907Q parallel control bus operate with 1.8 V or 3.3 V levels ( $V_{DDIO}$ ) for host compatibility. The 1.8 V levels will offer a system power savings.

## OPTIONAL SERIAL BUS CONTROL

Please see the following section on the [Optional Serial Bus Control Interface](#).



## Built In Self Test (BIST)

An optional At-Speed Built In Self Test (BIST) feature supports the testing of the high-speed serial link. This is useful in the prototype stage, equipment production, in-system test and also for system diagnostics. In the BIST mode only a input clock is required along with control to the DS90UR907Q and deserializer BISTEN input pins. The DS90UR907Q outputs a test pattern (PRBS7) and drives the link at speed. The deserializer detects the PRBS7 pattern and monitors it for errors. A PASS output pin toggles to flag any payloads that are received with 1 to 24 errors. Upon completion of the test, the result of the test is held on the PASS output until reset (new BIST test or Power Down). A high on PASS indicates NO ERRORS were detected. A Low on PASS indicates one or more errors were detected. The duration of the test is controlled by the pulse width applied to the deserializer BISTEN pin.

Inter-operability is supported between this FPD-Link II device and all FPD-Link II generations (Gen 1/2/3) — see respective datasheets for details on entering BIST mode and control.

### Sample BIST Sequence

See [Figure 20](#) for the BIST mode flow diagram.

**Step 1:** Place the DS90UR907Q in BIST Mode by setting Ser BISTEN = H. The BIST Mode is enabled via the BISTEN pin. An RxCLKIN is required for all the Ser options. When the deserializer detects the BIST mode pattern and command (DCA and DCB code) the RGB and control signal outputs are shut off.

**Step 2:** Place the pairing deserializer in BIST mode by setting the BISTEN = H. The Des is now in the BIST mode and checks the incoming serial payloads for errors. If an error in the payload (1 to 24) is detected, the PASS pin will switch low for one half of the clock period. During the BIST test, the PASS output can be monitored and counted to determine the payload error rate.

**Step 3:** To Stop the BIST mode, the deserializer BISTEN pin is set Low. The deserializer stops checking the data and the final test result is held on the PASS pin. If the test ran error free, the PASS output will be High. If there was one or more errors detected, the PASS output will be Low. The PASS output state is held until a new BIST is run, the device is RESET, or Powered Down. The BIST duration is user controlled by the duration of the BISTEN signal.

**Step 4:** To return the link to normal operation, the DS90UR907Q BISTEN input is set Low. The Link returns to normal operation.

[Figure 21](#) shows the waveform diagram of a typical BIST test for two cases. Case 1 is error free, and Case 2 shows one with multiple errors. In most cases it is difficult to generate errors due to the robustness of the link (differential data transmission etc.), thus they may be introduced by greatly extending the cable length, faulting the interconnect, reducing signal condition enhancements (De-Emphasis, VODSEL, or deserializer Equalization).

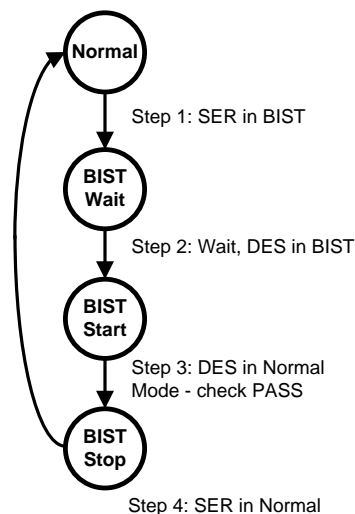

**Figure 20. BIST Mode Flow Diagram**

## BER Calculations

It is possible to calculate the approximate Bit Error Rate (BER). The following is required:

- Pixel Clock Frequency (MHz)
- BIST Duration (seconds)
- BIST test Result (PASS)

The BER is less than or equal to one over the product of 24 times the RxCLKIN rate times the test duration. If we assume a 65MHz RxCLKIN, a 10 minute (600 second) test, and a PASS, the BERT is  $\leq 1.07 \times 10^{-12}$

The BIST mode runs a check on the data payload bits. The LOCK pin also provides a link status. If the recovery of the C0 and C1 bits does not reconstruct the expected clock signal, the LOCK pin will switch Low. The combination of the LOCK and At-Speed BIST PASS pin provides a powerful tool for system evaluation and performance monitoring.

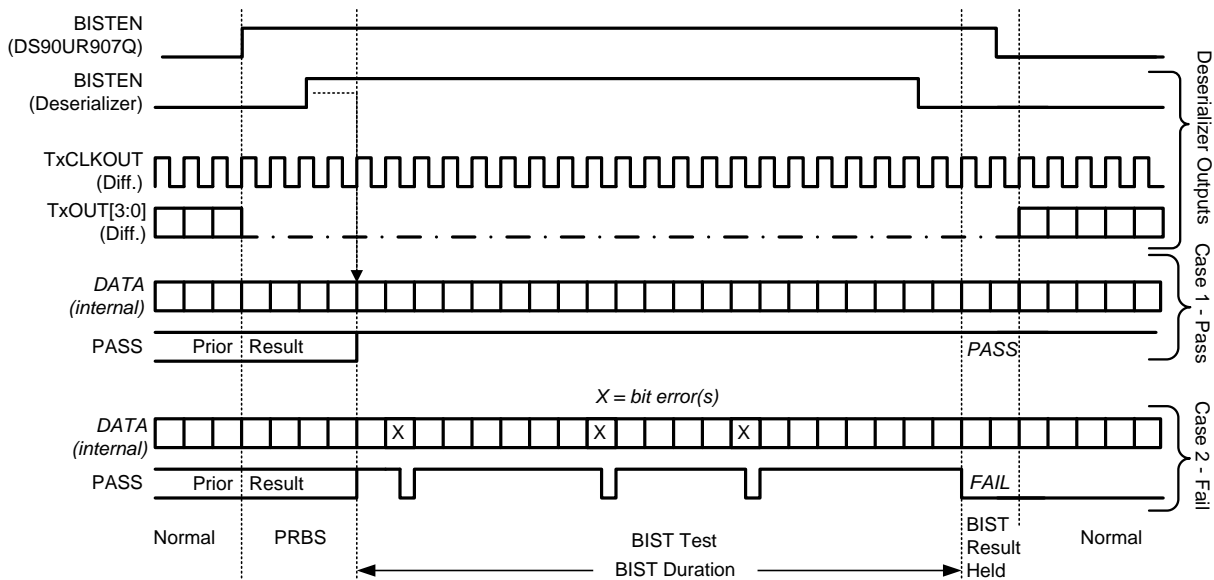

**Figure 21. BIST Waveforms**

## Optional Serial Bus Control

The DS90UR907Q may be configured by the use of a serial control bus that is I2C protocol compatible. By default, the I2C reg\_0x00'h is set to 00'h and all configuration is set by control/strap pins. A write of 01'h to reg\_0x00'h will enable/allow configuration by registers; this will override the control/strap pins. Multiple devices may share the serial control bus since multiple addresses are supported. See [Figure 22](#).

The serial bus is comprised of three pins. The SCL is a Serial Bus Clock Input. The SDA is the Serial Bus Data Input / Output signal. Both SCL and SDA signals require an external pull up resistor to  $V_{DDIO}$ . For most applications a 4.7 k pull up resistor to  $V_{DDIO}$  may be used. The resistor value may be adjusted for capacitive loading and data rate requirements. The signals are either pulled High, or driven Low.

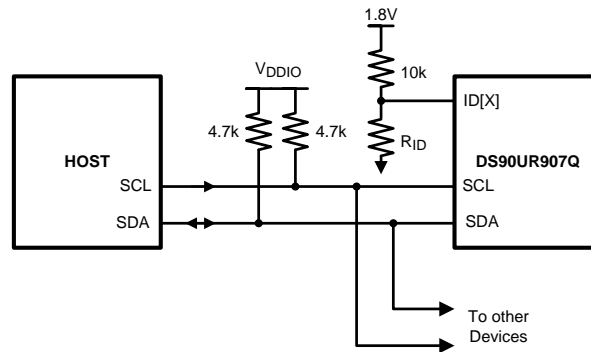

Figure 22. Serial Control Bus Connection

The third pin is the ID[X] pin. This pin sets one of four possible device addresses. Two different connections are possible. The pin may be pulled to  $V_{DD}$  (1.8V, NOT  $V_{DDIO}$ ) with a 10 k $\Omega$  resistor. Or a 10 k $\Omega$  pull up resistor (to  $V_{DD}$  1.8V, NOT  $V_{DDIO}$ ) and a pull down resistor of the recommended value to set other three possible addresses may be used. See Table 4.

The Serial Bus protocol is controlled by START, START-Repeated, and STOP phases. A START occurs when SCL transitions Low while SDA is High. A STOP occurs when SDA transition High while SCL is also HIGH. See Figure 23.

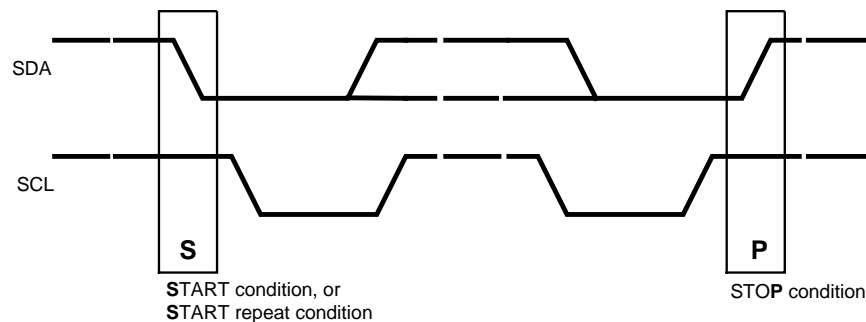

Figure 23. START and STOP Conditions

To communicate with a remote device, the host controller (master) sends the slave address and listens for a response from the slave. This response is referred to as an acknowledge bit (ACK). If a slave on the bus is addressed correctly, it Acknowledges (ACKs) the master by driving the SDA bus low. If the address doesn't match a device's slave address, it Not-acknowledges (NACKs) the master by letting SDA be pulled High. ACKs also occur on the bus when data is being transmitted. When the master is writing data, the slave ACKs after every data byte is successfully received. When the master is reading data, the master ACKs after every data byte is received to let the slave know it wants to receive another data byte. When the master wants to stop reading, it NACKs after the last data byte and creates a stop condition on the bus. All communication on the bus begins with either a Start condition or a Repeated Start condition. All communication on the bus ends with a Stop condition. A READ is shown in Figure 24 and a WRITE is shown in Figure 25.

If the Serial Bus is not required, the three pins may be left open (NC).

Table 4. ID[x] Resistor Value – DS90UR907Q

Resistor R <sub>ID</sub> k $\Omega$	Address 7'b	Address 8'b 0 appended (WRITE)
0.47	7b' 110 1001 (h'69)	8b' 1101 0010 (h'D2)
2.7	7b' 110 1010 (h'6A)	8b' 1101 0100 (h'D4)
8.2	7b' 110 1011 (h'6B)	8b' 1101 0110 (h'D6)
Open	7b' 110 1110 (h'6E)	8b' 1101 1100 (h'DC)

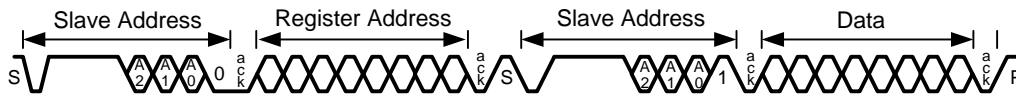

Figure 24. Serial Control Bus — READ

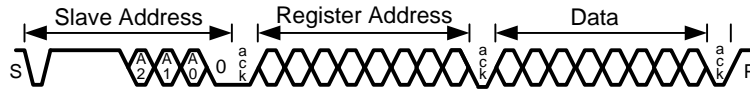

Figure 25. Serial Control Bus — WRITE

Table 5. Serial Bus Control Registers

ADD (dec)	ADD (hex)	Register Name	Bit(s)	R/W	Default (bin)	Function	Description
0	0	Ser Config 1	7	R/W	0	<b>Reserved</b>	<b>Reserved</b>
			6	R/W	0	MAPSEL	0: LSB on RxIN3 1: MSB on RxIN3
			5	R/W	0	VODSEL	0: Low 1: High
			4	R/W	0	<b>Reserved</b>	<b>Reserved</b>
			3:2	R/W	00	CONFIG	00: Normal Mode, Control Signal Filter DISABLED 01: Normal Mode, Control Signal Filter ENABLED 10: Backwards Compatible (DS90UR124, DS99R124) 11: Backwards Compatible (DS90C124)
			1	R/W	0	SLEEP	Note – not the same function as PowerDown (PDB) 0: normal mode 1: Sleep Mode – <b>Register settings retained.</b>
			0	R/W	0	REG	0: Configurations set from control pins 1: Configuration set from registers (except I2C_ID)
1	1	Device ID	7	R/W	0	REG ID	0: Address from ID[X] Pin 1: Address from Register
			6:0	R/W	110100	ID[X]	Serial Bus Device ID, Five IDs are: 7b '1101 000 (h'68) 7b '1101 001 (h'69) 7b '1101 010 (h'6A) 7b '1101 011 (h'6B) 7b '1101 110 (h'6E) All other addresses are <b>Reserved</b> .
2	2	De-Emphasis Control	7:5	R/W	000	De-E Setting	000: set by external Resistor 001: -1 dB 010: -2 dB 011: -3.3 dB 100: -5 dB 101: -6.7 dB 110: -9 dB 111: -12 dB
			4	R/W	0	De-E EN	0: De-Emphasis Enabled 1: De-Emphasis Disabled
			3:0	R/W	000	<b>Reserved</b>	<b>Reserved</b>

APPLICATIONS INFORMATION

DISPLAY APPLICATION

The DS90UR907Q and DS90UR908Q chipset is intended for interface between a host (graphics processor) and a Display. It supports an 24-bit color depth (RGB888) and up to 1024 X 768 display formats. In a RGB888 application, 24 color bits (R[7:0], G[7:0], B[7:0]), Pixel Clock (PCLK) and three control bits (VS, HS and DE) are supported across the serial link with PCLK rates from 5 to 65 MHz. The chipset may also be used in 18-bit color applications. In this application three to six general purpose signals may also be sent from host to display.

TYPICAL APPLICATION CONNECTION

Figure 26 shows a typical application of the DS90UR907Q for a 65 MHz 24-bit Color Display Application. The LVDS inputs of the FPD-Link interface require external 100Ω terminations. The LVDS outputs of FPD-Link II require 100 nF AC coupling capacitors to the line. The line driver includes internal termination. Bypass capacitors are placed near the power supply pins. At a minimum, four 0.1 μF capacitors and a 4.7 μF capacitor should be used for local device bypassing. System GPO (General Purpose Output) signals control the PDB and BISTEN pins. The application assumes the companion deserializer (DS90UR908Q) therefore the configuration pins are also both tied Low. In this example the cable is long, therefore the VODSEL pin is tied High and a De-Emphasis value is selected by the resistor R1. The interface to the host is with 1.8 V LVCMOS levels, thus the VDDIO pin is connected also to the 1.8V rail. The Optional Serial Bus Control is not used in this example, thus the SCL, SDA and ID[x] pins are left open. A delay capacitor and resistor is placed on the PDB signal to delay the enabling of the device until power is stable. Bypass capacitors are placed near the power supply pins. Ferrite beads are placed on the power lines for effective noise suppression.

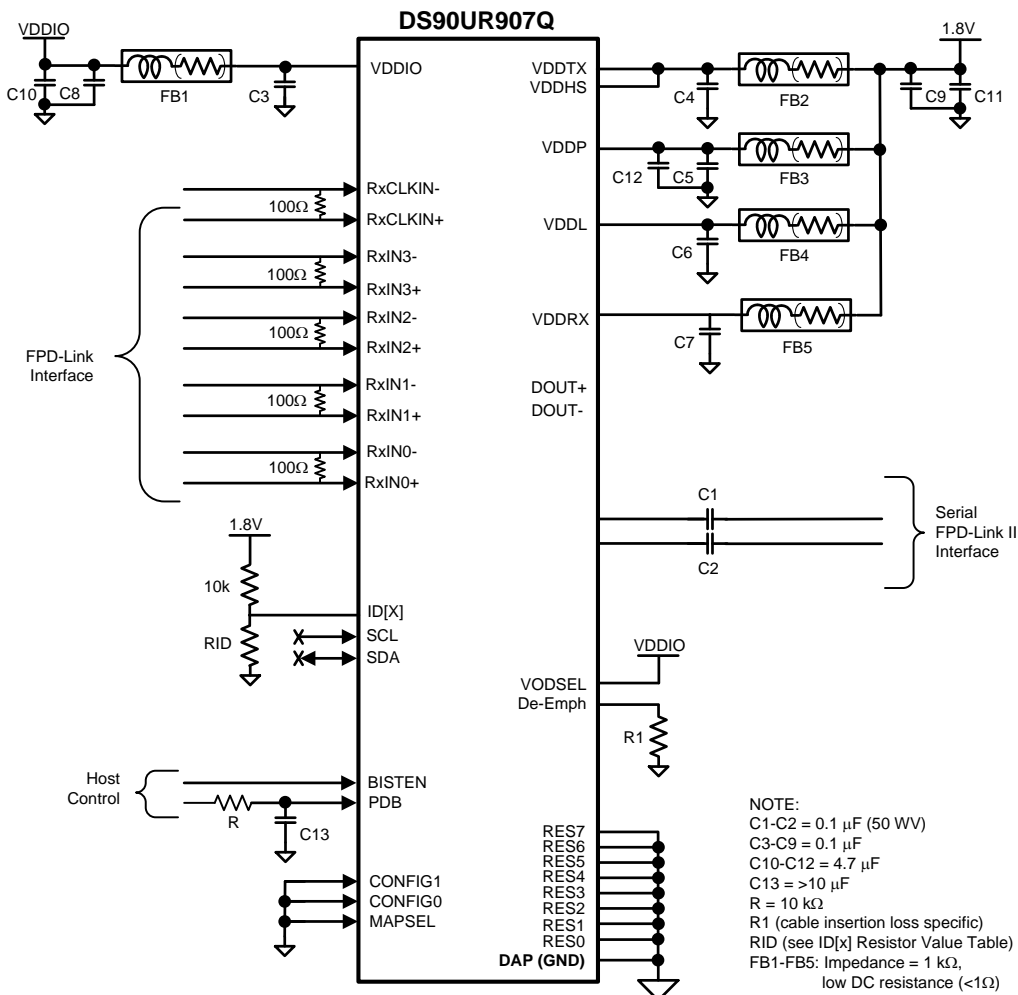

Figure 26. Typical Connection Diagram

## POWER UP REQUIREMENTS AND PDB PIN

The VDD ( $V_{DDn}$  and  $V_{DDIO}$ ) supply ramp should be faster than 1.5 ms with a monotonic rise. If slower than 1.5 ms then a capacitor on the PDB pin is needed to ensure PDB arrives after all the VDD have settled to the recommended operating voltage. When PDB pin is pulled to  $V_{DDIO}$ , it is recommended to use a 10 k $\Omega$  pull-up and a 22  $\mu$ F cap to GND to delay the PDB input signal.

## TRANSMISSION MEDIA

The DS90UR907Q and the companion deserializer chipset is intended to be used in a point-to-point configuration, through a PCB trace, or through twisted pair cable. The DS90UR907Q provide internal terminations providing a clean signaling environment. The interconnect for LVDS should present a differential impedance of 100 Ohms. Use cables and connectors that have matched differential impedance to minimize impedance discontinuities. Shielded or un-shielded cables may be used depending upon the noise environment and application requirements.

## ALTERNATE COLOR / DATA MAPPING

Color Mapped data pin names are provided to specify a recommended mapping for 24-bit and 18-bit Applications. When connecting to earlier generations of FPD-Link II deserializer devices, a color mapping review is recommended to ensure the correct connectivity is obtained. [Table 6](#) provides examples for interfacing between DS90UR907Q and different deserializers.

**Table 6. Alternate Color / Data Mapping**

FPD-Link	Bit Number	RGB (LSB Example)		DS90UR906Q	DS90UR124	DS99R124Q	DS90C124
RxIN3	Bit 26	B1		B1	N/A		
	Bit 25	B0		B0			
	Bit 24	G1		G1			
	Bit 23	G0		G0			
	Bit 22	R1		R1			
RxIN2	Bit 21	R0		R0			
	Bit 20	DE		DE	ROUT20	TxOUT2	ROUT20
	Bit 19	VS		VS	ROUT19		ROUT19
	Bit 18	HS		HS	ROUT18		ROUT18
	Bit 17	B7		B7	ROUT17		ROUT17
	Bit 16	B6		B6ROUT10	ROUT16		ROUT16
	Bit 15	B5		B5	ROUT15		ROUT15
Bit 14	B4		B4	ROUT14	ROUT14		
RxIN1	Bit 13	B3		B3	ROUT13	TxOUT1	ROUT13
	Bit 12	B2		B2	ROUT12		ROUT12
	Bit 11	G7		G7	ROUT11		ROUT11
	Bit 10	G6		G6	ROUT10		ROUT10
	Bit 9	G5		G5	ROUT9		ROUT9
	Bit 8	G4		G4	ROUT8		ROUT8
RxIN0	Bit 7	G3		G3	ROUT7		ROUT7
	Bit 6	G2		G2	ROUT6	TxOUT0	ROUT6
	Bit 5	R7		R7	ROUT5		ROUT5
	Bit 4	R6		R6	ROUT4		ROUT4
	Bit 3	R5		R5	ROUT3		ROUT3
	Bit 2	R4		R4	ROUT2		ROUT2
	Bit 1	R3		R3	ROUT1		ROUT1
Bit 0	R2		R2	ROUT0	ROUT0		

**Table 6. Alternate Color / Data Mapping (continued)**

FPD-Link	Bit Number	RGB (LSB Example)		DS90UR906Q	DS90UR124	DS99R124Q	DS90C124
N/A				N/A	ROUT23*	OS2*	ROUT23*
* These bits are not supported by DS90UR907Q					ROUT22*	OS1*	ROUT22*
					ROUT21*	OS0*	ROUT21*
<b>DS90UR907Q Settings</b>	<b>MAPSEL = 0</b>			<b>CONFIG [1:0] = 00</b>	<b>CONFIG [1:0] = 10</b>		<b>CONFIG [1:0] = 11</b>

## PCB LAYOUT AND POWER SYSTEM CONSIDERATIONS

Circuit board layout and stack-up for the LVDS devices should be designed to provide low-noise power feed to the device. Good layout practice will also separate high frequency or high-level inputs and outputs to minimize unwanted stray noise pickup, feedback and interference. Power system performance may be greatly improved by using thin dielectrics (2 to 4 mils) for power / ground sandwiches. This arrangement provides plane capacitance for the PCB power system with low-inductance parasitics, which has proven especially effective at high frequencies, and makes the value and placement of external bypass capacitors less critical. External bypass capacitors should include both RF ceramic and tantalum electrolytic types. RF capacitors may use values in the range of 0.01 uF to 0.1 uF. Tantalum capacitors may be in the 2.2 uF to 10 uF range. Voltage rating of the tantalum capacitors should be at least 5X the power supply voltage being used.

Surface mount capacitors are recommended due to their smaller parasitics. When using multiple capacitors per supply pin, locate the smaller value closer to the pin. A large bulk capacitor is recommended at the point of power entry. This is typically in the 50uF to 100uF range and will smooth low frequency switching noise. It is recommended to connect power and ground pins directly to the power and ground planes with bypass capacitors connected to the plane with via on both ends of the capacitor. Connecting power or ground pins to an external bypass capacitor will increase the inductance of the path.

A small body size X7R chip capacitor, such as 0603, is recommended for external bypass. Its small body size reduces the parasitic inductance of the capacitor. The user must pay attention to the resonance frequency of these external bypass capacitors, usually in the range of 20-30 MHz. To provide effective bypassing, multiple capacitors are often used to achieve low impedance between the supply rails over the frequency of interest. At high frequency, it is also a common practice to use two vias from power and ground pins to the planes, reducing the impedance at high frequency.

Some devices provide separate power and ground pins for different portions of the circuit. This is done to isolate switching noise effects between different sections of the circuit. Separate planes on the PCB are typically not required. Pin Description tables typically provide guidance on which circuit blocks are connected to which power pin pairs. In some cases, an external filter may be used to provide clean power to sensitive circuits such as PLLs.

Use at least a four layer board with a power and ground plane. Locate LVCMOS signals away from the LVDS lines to prevent coupling from the LVCMOS lines to the LVDS lines. Closely-coupled differential lines of 100 Ohms are typically recommended for LVDS interconnect. The closely coupled lines help to ensure that coupled noise will appear as common-mode and thus is rejected by the receivers. The tightly coupled lines will also radiate less.

## LVDS INTERCONNECT GUIDELINES

See [SNLA008](#) and [SNLA035](#) for full details.

- Use 100Ω coupled differential pairs
- Use the S/2S/3S rule in spacings
  - S = space between the pair
  - 2S = space between pairs
  - 3S = space to LVCMOS signal
- Minimize the number of Vias
- Use differential connectors when operating above 500Mbps line speed
- Maintain balance of the traces
- Minimize skew within the pair
- Terminate as close to the TX outputs and RX inputs as possible

Additional general guidance can be found in the LVDS Owner's Manual - available in PDF format from the TI web site at: [www.ti.com/lvds](http://www.ti.com/lvds)



---

**REVISION HISTORY**

<b>Changes from Revision E (April 2013) to Revision F</b>	<b>Page</b>
• Changed layout of National Data Sheet to TI format .....	<a href="#">24</a>

---

**PACKAGING INFORMATION**

Orderable Device	Status (1)	Package Type	Package Drawing	Pins	Package Qty	Eco Plan (2)	Lead finish/ Ball material (6)	MSL Peak Temp (3)	Op Temp (°C)	Device Marking (4/5)	Samples
DS90UR907QSQ/NOPB	ACTIVE	WQFN	NJK	36	1000	RoHS & Green	SN	Level-3-260C-168 HR	-40 to 105	UR907QSQ	<a href="#">Samples</a>
DS90UR907QSQE/NOPB	ACTIVE	WQFN	NJK	36	250	RoHS & Green	SN	Level-3-260C-168 HR	-40 to 105	UR907QSQ	<a href="#">Samples</a>
DS90UR907QSQX/NOPB	ACTIVE	WQFN	NJK	36	2500	RoHS & Green	SN	Level-3-260C-168 HR	-40 to 105	UR907QSQ	<a href="#">Samples</a>

(1) The marketing status values are defined as follows:

**ACTIVE:** Product device recommended for new designs.

**LIFEBUY:** TI has announced that the device will be discontinued, and a lifetime-buy period is in effect.

**NRND:** Not recommended for new designs. Device is in production to support existing customers, but TI does not recommend using this part in a new design.

**PREVIEW:** Device has been announced but is not in production. Samples may or may not be available.

**OBSOLETE:** TI has discontinued the production of the device.

(2) **RoHS:** TI defines "RoHS" to mean semiconductor products that are compliant with the current EU RoHS requirements for all 10 RoHS substances, including the requirement that RoHS substance do not exceed 0.1% by weight in homogeneous materials. Where designed to be soldered at high temperatures, "RoHS" products are suitable for use in specified lead-free processes. TI may reference these types of products as "Pb-Free".

**RoHS Exempt:** TI defines "RoHS Exempt" to mean products that contain lead but are compliant with EU RoHS pursuant to a specific EU RoHS exemption.

**Green:** TI defines "Green" to mean the content of Chlorine (Cl) and Bromine (Br) based flame retardants meet JS709B low halogen requirements of <=1000ppm threshold. Antimony trioxide based flame retardants must also meet the <=1000ppm threshold requirement.

(3) MSL, Peak Temp. - The Moisture Sensitivity Level rating according to the JEDEC industry standard classifications, and peak solder temperature.

(4) There may be additional marking, which relates to the logo, the lot trace code information, or the environmental category on the device.

(5) Multiple Device Markings will be inside parentheses. Only one Device Marking contained in parentheses and separated by a "~" will appear on a device. If a line is indented then it is a continuation of the previous line and the two combined represent the entire Device Marking for that device.

(6) Lead finish/Ball material - Orderable Devices may have multiple material finish options. Finish options are separated by a vertical ruled line. Lead finish/Ball material values may wrap to two lines if the finish value exceeds the maximum column width.

**Important Information and Disclaimer:**The information provided on this page represents TI's knowledge and belief as of the date that it is provided. TI bases its knowledge and belief on information provided by third parties, and makes no representation or warranty as to the accuracy of such information. Efforts are underway to better integrate information from third parties. TI has taken and continues to take reasonable steps to provide representative and accurate information but may not have conducted destructive testing or chemical analysis on incoming materials and chemicals. TI and TI suppliers consider certain information to be proprietary, and thus CAS numbers and other limited information may not be available for release.

In no event shall TI's liability arising out of such information exceed the total purchase price of the TI part(s) at issue in this document sold by TI to Customer on an annual basis.

**TAPE AND REEL INFORMATION**

**QUADRANT ASSIGNMENTS FOR PIN 1 ORIENTATION IN TAPE**

\*All dimensions are nominal

Device	Package Type	Package Drawing	Pins	SPQ	Reel Diameter (mm)	Reel Width W1 (mm)	A0 (mm)	B0 (mm)	K0 (mm)	P1 (mm)	W (mm)	Pin1 Quadrant
DS90UR907QSQ/NOPB	WQFN	NJK	36	1000	330.0	16.4	6.3	6.3	1.5	12.0	16.0	Q1
DS90UR907QSQE/NOPB	WQFN	NJK	36	250	178.0	16.4	6.3	6.3	1.5	12.0	16.0	Q1
DS90UR907QSQX/NOPB	WQFN	NJK	36	2500	330.0	16.4	6.3	6.3	1.5	12.0	16.0	Q1

## TAPE AND REEL BOX DIMENSIONS



\*All dimensions are nominal

Device	Package Type	Package Drawing	Pins	SPQ	Length (mm)	Width (mm)	Height (mm)
DS90UR907QSQ/NOPB	WQFN	NJK	36	1000	356.0	356.0	36.0
DS90UR907QSQE/NOPB	WQFN	NJK	36	250	208.0	191.0	35.0
DS90UR907QSQX/NOPB	WQFN	NJK	36	2500	356.0	356.0	36.0

NJK0036A

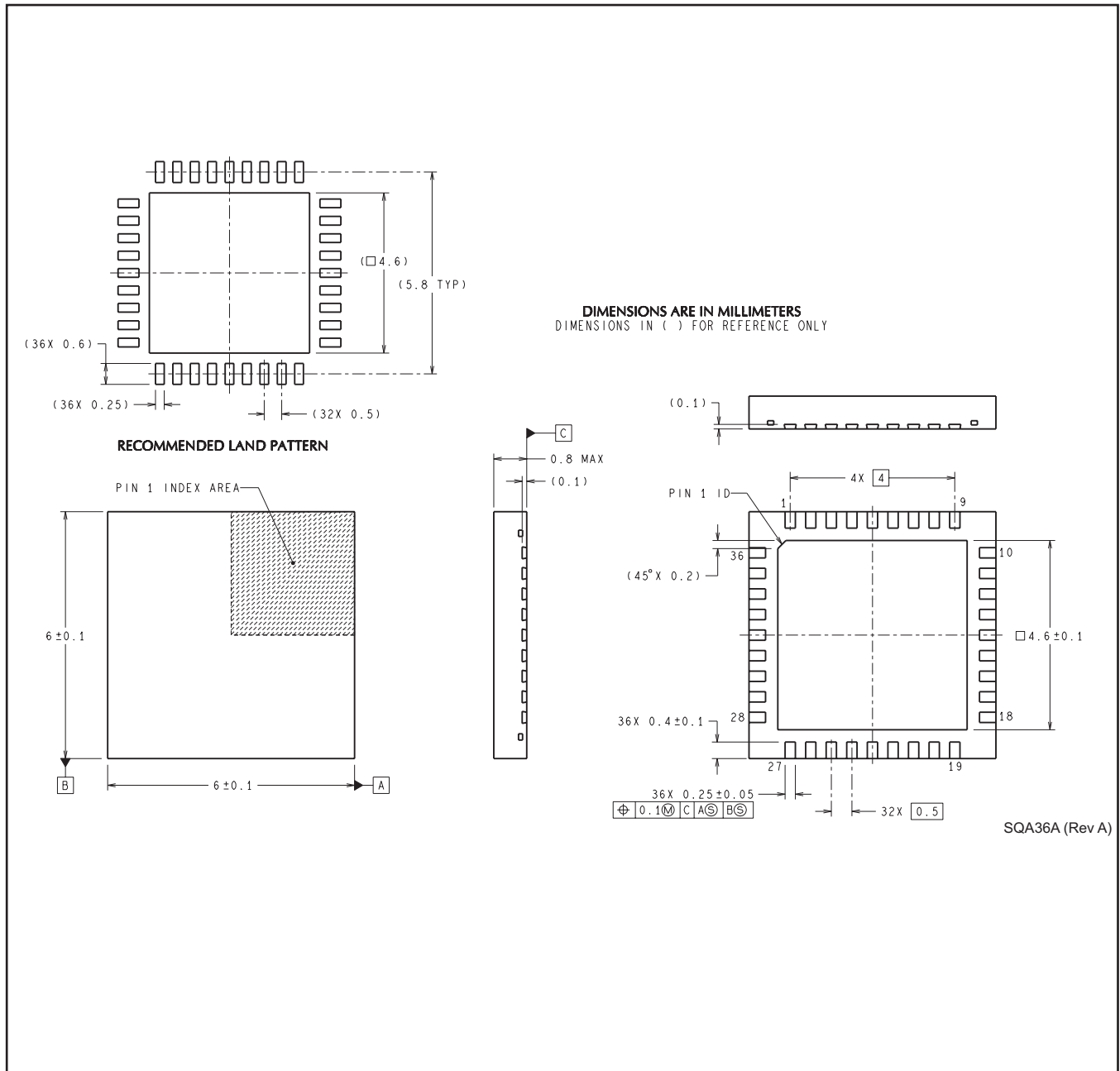

## 重要声明和免责声明

TI“按原样”提供技术和可靠性数据（包括数据表）、设计资源（包括参考设计）、应用或其他设计建议、网络工具、安全信息和其他资源，不保证没有瑕疵且不做任何明示或暗示的担保，包括但不限于对适销性、某特定用途方面的适用性或不侵犯任何第三方知识产权的暗示担保。

这些资源可供使用 TI 产品进行设计的熟练开发人员使用。您将自行承担以下全部责任：(1) 针对您的应用选择合适的 TI 产品，(2) 设计、验证并测试您的应用，(3) 确保您的应用满足相应标准以及任何其他功能安全、信息安全、监管或其他要求。

这些资源如有变更，恕不另行通知。TI 授权您仅可将这些资源用于研发本资源所述的 TI 产品的应用。严禁对这些资源进行其他复制或展示。您无权使用任何其他 TI 知识产权或任何第三方知识产权。您应全额赔偿因在这些资源的使用中对 TI 及其代表造成的任何索赔、损害、成本、损失和债务，TI 对此概不负责。

TI 提供的产品受 [TI 的销售条款](#) 或 [ti.com](#) 上其他适用条款/TI 产品随附的其他适用条款的约束。TI 提供这些资源并不会扩展或以其他方式更改 TI 针对 TI 产品发布的适用的担保或担保免责声明。

TI 反对并拒绝您可能提出的任何其他或不同的条款。

邮寄地址：Texas Instruments, Post Office Box 655303, Dallas, Texas 75265

Copyright © 2024，德州仪器 (TI) 公司