

## 具有复位功能的 PCA9546A 低压 4 通道 I<sup>2</sup>C 和 SMBus 开关

### 1 特性

- 4 选 1 双向转换开关
- 与 I<sup>2</sup>C 总线和 SMBus 兼容
- 低电平有效复位输入
- 三个地址引脚，允许在 I<sup>2</sup>C 总线上使用多达八个 PCA9546A 器件
- 以任意组合通过 I<sup>2</sup>C 总线实现通道选择
- 加电时所有开关通道取消选定
- 低 R<sub>ON</sub> 开关
- 支持 1.8V、2.5V、3.3V 和 5V 总线间的电压电平转换
- 加电时无干扰
- 支持热插入
- 低待机电流
- 工作电源电压范围为 2.3V 至 5.5V
- 5.5V 耐压输入
- 0 至 400kHz 时钟频率
- 锁断性能超过了 100mA，符合 JESD 78 规范
- ESD 保护性能超过 JESD 22 规范要求
  - 2000V 人体放电模型 (A114-A)
  - 1000V 带电器件模型 (C101)

### 2 应用

- 服务器
- 路由器 ( 电信交换设备 )
- 工厂自动化
- 具有 I<sup>2</sup>C 从地址冲突的产品 ( 例如，多个完全一样的温度传感器 )

### 3 说明

PCA9546A 是一款由 I<sup>2</sup>C 总线控制的四路双向转换开关。SCL/SDA 上行对扩展到四个下行对，或者通道。根据可编程控制寄存器的内容，可选择任一单独 SCn/SDn 通道或者通道组合。

一个低电平有效 ( $\overline{\text{RESET}}$ ) 输入使得 PCA9546A 能够在其中一个下行 I<sup>2</sup>C 总线长时间处于低电平状态时恢复。将  $\overline{\text{RESET}}$  下拉为低电平会使 I<sup>2</sup>C 状态机复位，并且使所有通道取消选中，这一功能与内部上电复位功能的作用一样。

由于开关上有导通栅极，因此 V<sub>CC</sub> 引脚可用于限制将由 PCA9546A 传递的最大电压。这允许在每个对上使用不同的总线电压，以便 1.8V、2.5V 或 3.3V 部件可以在没有任何额外保护的情况下与 5V 部件通信。对于每个通道，外部上拉电阻器将总线电压上拉至所需的电压电平。所有 I/O 引脚为 5.5V 耐压。

#### 封装信息

器件型号	封装 <sup>(1)</sup>	封装尺寸 ( 标称值 )
PCA9546A	SOIC (D) (16)	9.90mm x 3.91mm
	TVSOP (DGV) (16)	3.60mm x 4.40mm
	SOIC (DW) (16)	10.3mm x 7.50mm
	TSSOP (PW) (16)	5.00mm x 4.40mm
	VQFN (RGV) 16	4.00mm x 4.00mm
	VQFN (RGY) (16)	4.50mm x 3.50mm

(1) 如需了解所有可用封装，请见数据表末尾的可订购产品附录。

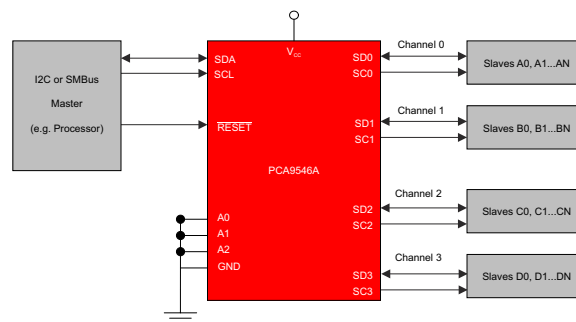

Copyright © 2016, Texas Instruments Incorporated

简化版应用示意图



## Table of Contents

<b>1 特性</b> .....	1	8.4 Device Functional Modes.....	11
<b>2 应用</b> .....	1	8.5 Programming.....	11
<b>3 说明</b> .....	1	8.6 Control Register.....	14
<b>4 Revision History</b> .....	2	<b>9 Application Information Disclaimer</b> .....	16
<b>5 Pin Configuration and Functions</b> .....	3	9.1 Application Information.....	16
<b>6 Specifications</b> .....	4	9.2 Typical Application.....	16
6.1 Absolute Maximum Ratings.....	4	<b>10 Power Supply Recommendations</b> .....	19
6.2 ESD Ratings.....	4	10.1 Power-On Reset Requirements.....	19
6.3 Recommended Operating Conditions.....	4	<b>11 Layout</b> .....	21
6.4 Thermal Information.....	4	11.1 Layout Guidelines.....	21
6.5 Electrical Characteristics.....	5	11.2 Layout Example.....	21
6.6 I <sup>2</sup> C Interface Timing Requirements.....	6	<b>12 Device and Documentation Support</b> .....	22
6.7 Interrupt and Reset Timing Requirements.....	7	12.1 接收文档更新通知.....	22
6.8 Switching Characteristics.....	7	12.2 支持资源.....	22
<b>7 Parameter Measurement Information</b> .....	8	12.3 Trademarks.....	22
<b>8 Detailed Description</b> .....	10	12.4 Electrostatic Discharge Caution.....	22
8.1 Overview.....	10	12.5 术语表.....	22
8.2 Functional Block Diagram.....	10	<b>13 Mechanical, Packaging, and Orderable Information</b> .....	22
8.3 Feature Description.....	11		

## 4 Revision History

注：以前版本的页码可能与当前版本的页码不同

Changes from Revision H (March 2021) to Revision I (June 2022)	Page
• 将 TSSOP (PW) (16) 从 9.70mm x 4.40mm 更改为 5.00mm x 4.40mm (在封装信息表中) .....	1

Changes from Revision G (May 2016) to Revision H (March 2021)	Page
• 更改了封装信息表.....	1
• Moved the Package thermal impedance to the <i>Thermal Information</i> table.....	4
• Added the <i>Thermal Information</i> table.....	4
• Changed the V <sub>PORR</sub> row in the <i>Electrical Characteristics</i> .....	5
• Added V <sub>PORF</sub> row to the <i>Electrical Characteristics</i> .....	5
• Changed the I <sub>CC</sub> Low inputs and High inputs values in the <i>Electrical Characteristics</i> .....	5
• Changed the R <sub>on</sub> (4.5 V to 5.5 V) TYP value From: 9 Ω To: 10 Ω in the <i>Electrical Characteristics</i> .....	5
• Changed the R <sub>on</sub> (3 V to 3.6 V) TYP value From: 11 Ω To: 13 Ω in the <i>Electrical Characteristics</i> .....	5
• Changed the <i>Power Supply Recommendations</i> .....	19

Changes from Revision F (April 2014) to Revision G (May 2016)	Page
• Revised pack material addendum; pin 1 quadrant .....	22

Changes from Revision E (January 2008) to Revision F (April 2014)	Page
• Added RESET Errata section.....	11

## 5 Pin Configuration and Functions



表 5-1. Pin Functions

NAME	PIN NO.		DESCRIPTION
	D, DG, DW, PW, AND RGY	RGV	
A0	1	15	Address input 0. Connect directly to V <sub>CC</sub> or ground
A1	2	16	Address input 1. Connect directly to V <sub>CC</sub> or ground
A2	13	11	Address input 2. Connect directly to V <sub>CC</sub> or ground
GND	8	6	Ground
RESET	3	1	Active low reset input. Connect to V <sub>DPUM</sub> <sup>(1)</sup> through a pull-up resistor, if not used.
SD0	4	2	Serial data 0. Connect to V <sub>DPU0</sub> <sup>(1)</sup> through a pull-up resistor
SC0	5	3	Serial clock 0. Connect to V <sub>DPU0</sub> <sup>(1)</sup> through a pull-up resistor
SD1	6	4	Serial data 1. Connect to V <sub>DPU1</sub> <sup>(1)</sup> through a pull-up resistor
SC1	7	5	Serial clock 1. Connect to V <sub>DPU1</sub> <sup>(1)</sup> through a pull-up resistor
SD2	9	7	Serial data 2. Connect to V <sub>DPU2</sub> <sup>(1)</sup> through a pull-up resistor
SC2	10	8	Serial clock 2. Connect to V <sub>DPU2</sub> <sup>(1)</sup> through a pull-up resistor
SD3	11	9	Serial data 3. Connect to V <sub>DPU3</sub> <sup>(1)</sup> through a pull-up resistor.
SC3	12	10	Serial clock 3. Connect to V <sub>DPU3</sub> <sup>(1)</sup> through a pull-up resistor
SCL	14	12	Serial clock line. Connect to V <sub>DPUM</sub> <sup>(1)</sup> through a pull-up resistor
SDA	15	13	Serial data line. Connect to V <sub>DPUM</sub> <sup>(1)</sup> through a pull-up resistor
V <sub>CC</sub>	16	14	Supply power

(1) V<sub>DPUX</sub> is the pull-up reference voltage for the associated data line. V<sub>DPUM</sub> is the master I<sup>2</sup>C reference voltage while V<sub>DPU0</sub> - V<sub>DPU3</sub> are the slave channel reference voltages.

## 6 Specifications

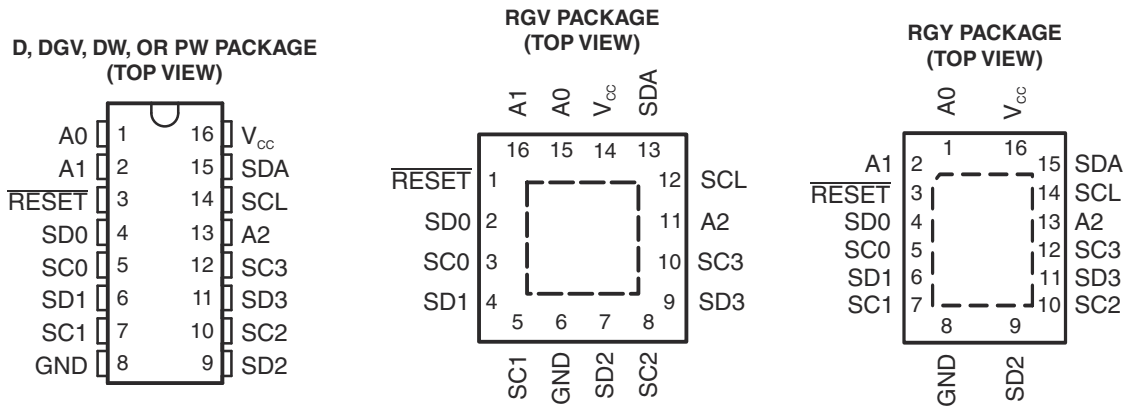
### 6.1 Absolute Maximum Ratings

over operating free-air temperature range (unless otherwise noted) <sup>(1)</sup>

		MIN	MAX	UNIT
V <sub>CC</sub>	Supply voltage	- 0.5	7	V
V <sub>I</sub>	Input voltage <sup>(2)</sup>	- 0.5	7	V
I <sub>I</sub>	Input current		±20	mA
I <sub>O</sub>	Output current		±25	mA
	Continuous current through V <sub>CC</sub>		±100	mA
	Continuous current through GND		±100	mA
P <sub>tot</sub>	Total power dissipation		400	mW
T <sub>A</sub>	Operating free-air temperature	- 40	85	°C
T <sub>stg</sub>	Storage temperature	- 65	150	

- (1) Stresses beyond those listed under *Absolute Maximum Ratings* may cause permanent damage to the device. These are stress ratings only, which do not imply functional operation of the device at these or any other conditions beyond those indicated under *Recommended Operating Conditions*. Exposure to absolute-maximum-rated conditions for extended periods may affect device reliability.
- (2) The input negative-voltage and output voltage ratings may be exceeded if the input and output current ratings are observed.

### 6.2 ESD Ratings

		VALUE	UNIT
V <sub>(ESD)</sub>	Electrostatic discharge	Human-body model (HBM), per ANSI/ESDA/JEDEC JS-001 <sup>(1)</sup>	±2000
		Charged-device model (CDM), per JEDEC specification JESD22-C101 <sup>(2)</sup>	±1000

- (1) JEDEC document JEP155 states that 500-V HBM allows safe manufacturing with a standard ESD control process.
- (2) JEDEC document JEP157 states that 250-V CDM allows safe manufacturing with a standard ESD control process.

### 6.3 Recommended Operating Conditions

See <sup>(1)</sup>

		MIN	MAX	UNIT
V <sub>CC</sub>	Supply voltage	2.3	5.5	V
V <sub>IH</sub>	High-level input voltage	SCL, SDA	0.7 × V <sub>CC</sub>	6
		A2 - A0, RESET	0.7 × V <sub>CC</sub>	V <sub>CC</sub> + 0.5
V <sub>IL</sub>	Low-level input voltage	SCL, SDA	- 0.5	0.3 × V <sub>CC</sub>
		A2 - A0, RESET	- 0.5	0.3 × V <sub>CC</sub>
T <sub>A</sub>	Operating free-air temperature	- 40	85	°C

- (1) All unused inputs of the device must be held at V<sub>CC</sub> or GND to ensure proper device operation. Refer to the TI application report, *Implications of Slow or Floating CMOS Inputs*, SCBA004.

### 6.4 Thermal Information

THERMAL METRIC <sup>(1)</sup>	PCA9546A						UNIT	
	DGV	DW	PW	RGV	RGY	D		
	16 PINS	16 PINS	16 PINS	16 PINS	16 PINS	16 PINS		
R <sub>θJA</sub>	Junction-to-ambient thermal resistance	120	57	122.3	63.2	50	92.3	°C/W

- (1) For more information about traditional and new thermal metrics, see the [Semiconductor and IC package thermal metrics application report](#).

## 6.5 Electrical Characteristics

over recommended operating free-air temperature range (unless otherwise noted)

PARAMETER		TEST CONDITIONS		V <sub>CC</sub>	MIN	TYP <sup>(1)</sup>	MAX	UNIT
V <sub>PORR</sub>	Power-on reset voltage, V <sub>CC</sub> rising	No load,	V <sub>I</sub> = V <sub>CC</sub> or GND			1.2	1.5	V
V <sub>PORF</sub>	Power-on reset voltage, V <sub>CC</sub> falling <sup>(2)</sup>	No load,	V <sub>I</sub> = V <sub>CC</sub> or GND		0.8	1		V
V <sub>pass</sub>	Switch output voltage	V <sub>SWin</sub> = V <sub>CC</sub> ,	I <sub>SWout</sub> = -100 μA	5 V		3.6		V
				4.5 V to 5.5 V	2.6	4.5		
				3.3 V		1.9		
				3 V to 3.6 V	1.6	2.8		
				2.5 V		1.5		
		2.3 V to 2.7 V		1.1	2			
I <sub>OL</sub>	SCL, SDA	V <sub>OL</sub> = 0.4 V		2.3 V to 5.5 V	3	7		mA
		V <sub>OL</sub> = 0.6 V			6	10		
I <sub>I</sub>	SCL, SDA	V <sub>I</sub> = V <sub>CC</sub> or GND		2.3 V to 5.5 V			±1	μA
	SC3 - SC0, SD3 - SD0						±1	
	A2 - A0						±1	
	RESET <sup>(4)</sup>						±1	
I <sub>CC</sub>	Operating mode	f <sub>SCL</sub> = 100 kHz	V <sub>I</sub> = V <sub>CC</sub> or GND, I <sub>O</sub> = 0	5.5 V	3	12	μA	
				3.6 V	3	11		
				2.7 V	3	10		
	Standby mode	Low inputs	V <sub>I</sub> = GND, I <sub>O</sub> = 0	5.5 V	1.6	2		
				3.6 V	1	1.3		
		2.7 V	0.7	1.1				
		High inputs	V <sub>I</sub> = V <sub>CC</sub> , I <sub>O</sub> = 0	5.5 V	1.6	2		
				3.6 V	1	1.3		
2.7 V	0.7	1.1						
Δ I <sub>CC</sub>	Supply-current change	SCL, SDA	SCL or SDA input at 0.6 V, Other inputs at V <sub>CC</sub> or GND		8	15	μA	
			SCL or SDA input at V <sub>CC</sub> - 0.6 V, Other inputs at V <sub>CC</sub> or GND	2.3 V to 5.5 V	8	15		
C <sub>i</sub>	A2 - A0	V <sub>I</sub> = V <sub>CC</sub> or GND		2.3 V to 5.5 V	4.5	6	pF	
	RESET				4.5	5.5		
C <sub>io(OFF)</sub> <sup>(3)</sup>	SCL, SDA	V <sub>I</sub> = V <sub>CC</sub> or GND, Switch OFF		2.3 V to 5.5 V	15	19	pF	
	SC3 - SC0, SD3 - SD0				6	8		
R <sub>ON</sub>	Switch on-state resistance	V <sub>O</sub> = 0.4 V, I <sub>O</sub> = 15 mA		4.5 V to 5.5 V	4	10	16	Ω
				3 V to 3.6 V	5	13	20	
				2.3 V to 2.7 V	7	16	45	

(1) All typical values are at nominal supply voltage (2.5-V, 3.3-V, or 5-V V<sub>CC</sub>). T<sub>A</sub> = 25°C.

(2) The power-on reset circuit resets the I2C bus logic with V<sub>CC</sub> < V<sub>PORF</sub>.

(3) C<sub>io(ON)</sub> depends on internal capacitance and external capacitance added to the SCn lines when channel(s) are ON.

(4) RESET = V<sub>CC</sub> (held high) when all other input voltages, V<sub>I</sub> = GND.

## 6.6 I<sup>2</sup>C Interface Timing Requirements

over recommended operating free-air temperature range (unless otherwise noted) (see 图 7-1)

		MIN	MAX	UNIT
<b>I<sup>2</sup>C BUS—STANDARD MODE</b>				
f <sub>scl</sub>	I <sup>2</sup> C clock frequency	0	100	kHz
t <sub>sch</sub>	I <sup>2</sup> C clock high time	4		μs
t <sub>scl</sub>	I <sup>2</sup> C clock low time	4.7		μs
t <sub>sp</sub>	I <sup>2</sup> C spike time		50	ns
t <sub>sds</sub>	I <sup>2</sup> C serial-data setup time	250		ns
t <sub>sdh</sub>	I <sup>2</sup> C serial-data hold time	0 <sup>(1)</sup>		ns
t <sub>icr</sub>	I <sup>2</sup> C input rise time		1000	ns
t <sub>icf</sub>	I <sup>2</sup> C input fall time		300	ns
t <sub>ocf</sub>	I <sup>2</sup> C output fall time	10-pF to 400-pF bus	300	ns
t <sub>buf</sub>	I <sup>2</sup> C bus free time between stop and start	4.7		μs
t <sub>sts</sub>	I <sup>2</sup> C start or repeated start condition setup	4.7		μs
t <sub>sth</sub>	I <sup>2</sup> C start or repeated start condition hold	4		μs
t <sub>sps</sub>	I <sup>2</sup> C stop condition setup	4		μs
t <sub>vdL(Data)</sub>	Valid data time (high to low) <sup>(2)</sup>	SCL low to SDA output low valid	1	μs
t <sub>vdH(Data)</sub>	Valid data time (low to high) <sup>(2)</sup>	SCL low to SDA output high valid	0.6	μs
t <sub>vd(ack)</sub>	Valid data time of ACK condition	ACK signal from SCL low to SDA (out) low	1	μs
C <sub>b</sub>	I <sup>2</sup> C bus capacitive load		400	pF

(1) A device internally must provide a hold time of at least 300 ns for the SDA signal (referred to the V<sub>IH</sub> min of the SCL signal), in order to bridge the undefined region of the falling edge of SCL.

(2) Data taken using a 1-kΩ pull-up resistor and 50-pF load (see 图 7-1)

		MIN	MAX	UNIT
<b>I<sup>2</sup>C BUS—FAST MODE</b>				
f <sub>scl</sub>	I <sup>2</sup> C clock frequency	0	400	kHz
t <sub>sch</sub>	I <sup>2</sup> C clock high time	0.6		μs
t <sub>scl</sub>	I <sup>2</sup> C clock low time	1.3		μs
t <sub>sp</sub>	I <sup>2</sup> C spike time		50	ns
t <sub>sds</sub>	I <sup>2</sup> C serial-data setup time	100		ns
t <sub>sdh</sub>	I <sup>2</sup> C serial-data hold time	0 <sup>(1)</sup>		ns
t <sub>icr</sub>	I <sup>2</sup> C input rise time	20 + 0.1C <sub>b</sub> <sup>(2)</sup>	300	ns
t <sub>icf</sub>	I <sup>2</sup> C input fall time	20 + 0.1C <sub>b</sub> <sup>(2)</sup>	300	ns
t <sub>ocf</sub>	I <sup>2</sup> C output fall time	10-pF to 400-pF bus	20 + 0.1C <sub>b</sub> <sup>(2)</sup>	300
t <sub>buf</sub>	I <sup>2</sup> C bus free time between stop and start	1.3		μs
t <sub>sts</sub>	I <sup>2</sup> C start or repeated start condition setup	0.6		μs
t <sub>sth</sub>	I <sup>2</sup> C start or repeated start condition hold	0.6		μs
t <sub>sps</sub>	I <sup>2</sup> C stop condition setup	0.6		μs
t <sub>vdL(Data)</sub>	Valid data time (high to low) <sup>(3)</sup>	SCL low to SDA output low valid	1	μs
t <sub>vdH(Data)</sub>	Valid data time (low to high) <sup>(3)</sup>	SCL low to SDA output high valid	0.6	
t <sub>vd(ack)</sub>	Valid data time of ACK condition	ACK signal from SCL low to SDA (out) low	1	μs
C <sub>b</sub>	I <sup>2</sup> C bus capacitive load		400	pF

(1) A device internally must provide a hold time of at least 300 ns for the SDA signal (referred to the V<sub>IH</sub> min of the SCL signal), in order to bridge the undefined region of the falling edge of SCL.

(2) C<sub>b</sub> = total bus capacitance of one bus line in pF

(3) Data taken using a 1-kΩ pull-up resistor and 50-pF load (see 图 7-1)

## 6.7 Interrupt and Reset Timing Requirements

over recommended operating free-air temperature range (unless otherwise noted)

PARAMETER		MIN	MAX	UNIT
$t_{WL}$	Pulse duration, RESET low	6		ns
$t_{rst}^{(1)}$	RESET time (SDA clear)		500	ns
$t_{REC(STA)}$	Recovery time from RESET to start	0		ns

- (1)  $t_{rst}$  is the propagation delay measured from the time the RESET pin is first asserted low to the time the SDA pin is asserted high, signaling a stop condition. It must be a minimum of  $t_{WL}$ .

## 6.8 Switching Characteristics

over recommended operating free-air temperature range,  $C_L \leq 100$  pF (unless otherwise noted) (see [Figure 7-1](#))

PARAMETER		FROM (INPUT)	TO (OUTPUT)	MIN	MAX	UNIT
$t_{pd}^{(1)}$	Propagation delay time	SDA or SCL	SDn or SCn		0.3	ns
					1	

- (1) The propagation delay is the calculated RC time constant of the typical ON-state resistance of the switch and the specified load capacitance, when driven by an ideal voltage source (zero output impedance).

## 7 Parameter Measurement Information

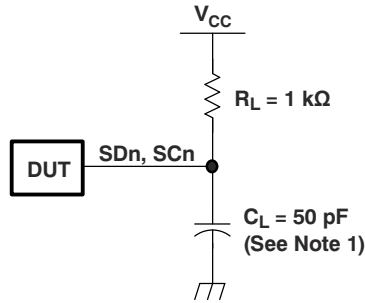

Copyright © 2016, Texas Instruments Incorporated  
**I<sup>2</sup>C PORT LOAD CONFIGURATION**

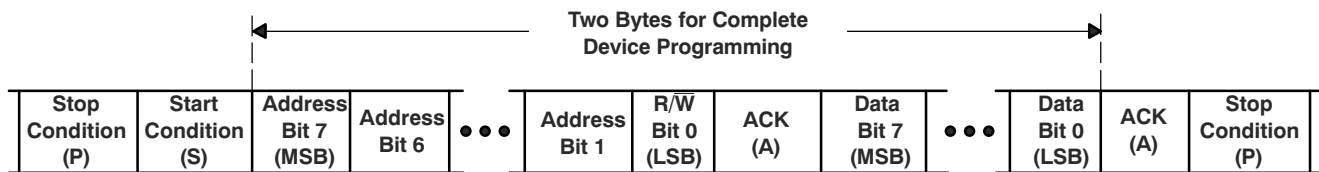

BYTE	DESCRIPTION
1	I <sup>2</sup> C address + R/W
2	Control register data

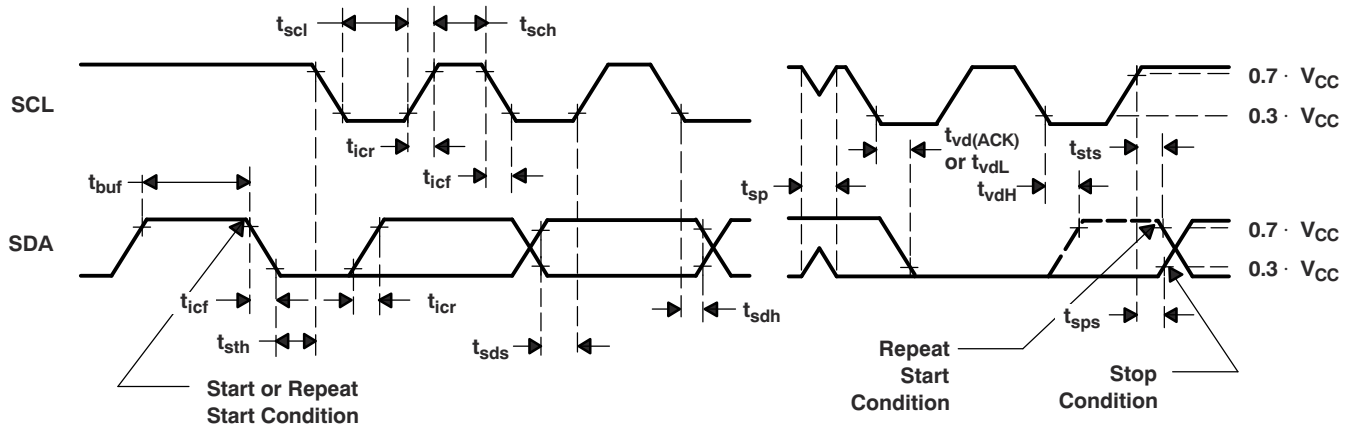

**VOLTAGE WAVEFORMS**

- A.  $C_L$  includes probe and jig capacitance.
- B. All input pulses are supplied by generators having the following characteristics:  $PRR \leq 10$  MHz,  $Z_O = 50 \Omega$ ,  $t_r/t_f \leq 30$  ns.
- C. The outputs are measured one at a time, with one transition per measurement.

**图 7-1. I<sup>2</sup>C Interface Load Circuit, Byte Descriptions, and Voltage Waveforms**





图 7-2. Reset Timing

## 8 Detailed Description

### 8.1 Overview

The PCA9546A is a 4-channel, bidirectional translating I<sup>2</sup>C switch. The master SCL/SDA signal pair is directed to four channels of slave devices, SC0/SD0-SC3/SD3. Any individual downstream channel can be selected as well as any combination of the four channels.

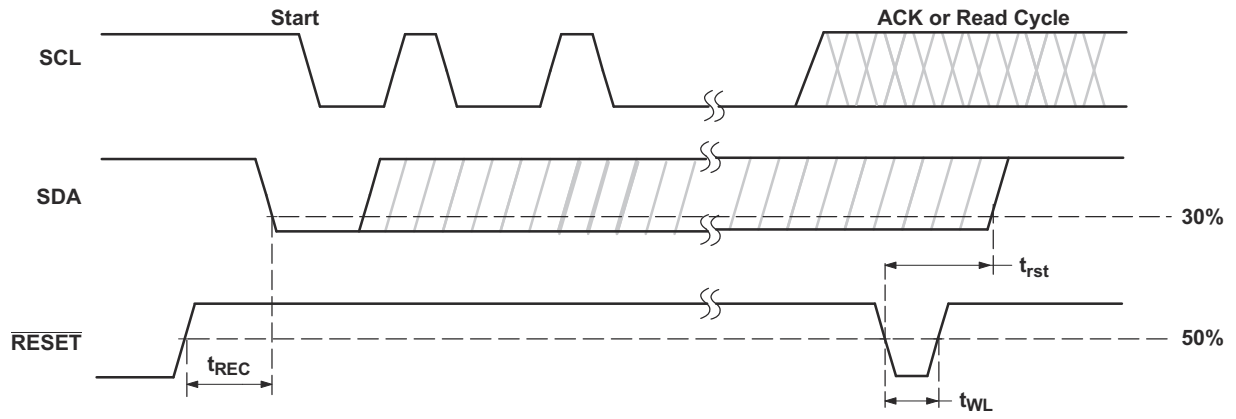
The device offers an active-low  $\overline{\text{RESET}}$  input which resets the state machine and allows the PCA9546A to recover should one of the downstream I<sup>2</sup>C buses get stuck in a low state. The state machine of the device can also be reset by cycling the power supply,  $V_{\text{CC}}$ , also known as a power-on reset (POR). Both the  $\overline{\text{RESET}}$  function and a POR will cause all channels to be deselected.

The connections of the I<sup>2</sup>C data path are controlled by the same I<sup>2</sup>C master device that is switched to communicate with multiple I<sup>2</sup>C slaves. After the successful acknowledgment of the slave address (hardware selectable by A0 and A1 pins), a single 8-bit control register is written to or read from to determine the selected channels.

The PCA9546A may also be used for voltage translation, allowing the use of different bus voltages on each SC<sub>n</sub>/SD<sub>n</sub> pair such that 1.8-V, 2.5-V, or 3.3-V parts can communicate with 5-V parts. This is achieved by using external pull-up resistors to pull the bus up to the desired voltage for the master and each slave channel.

### 8.2 Functional Block Diagram

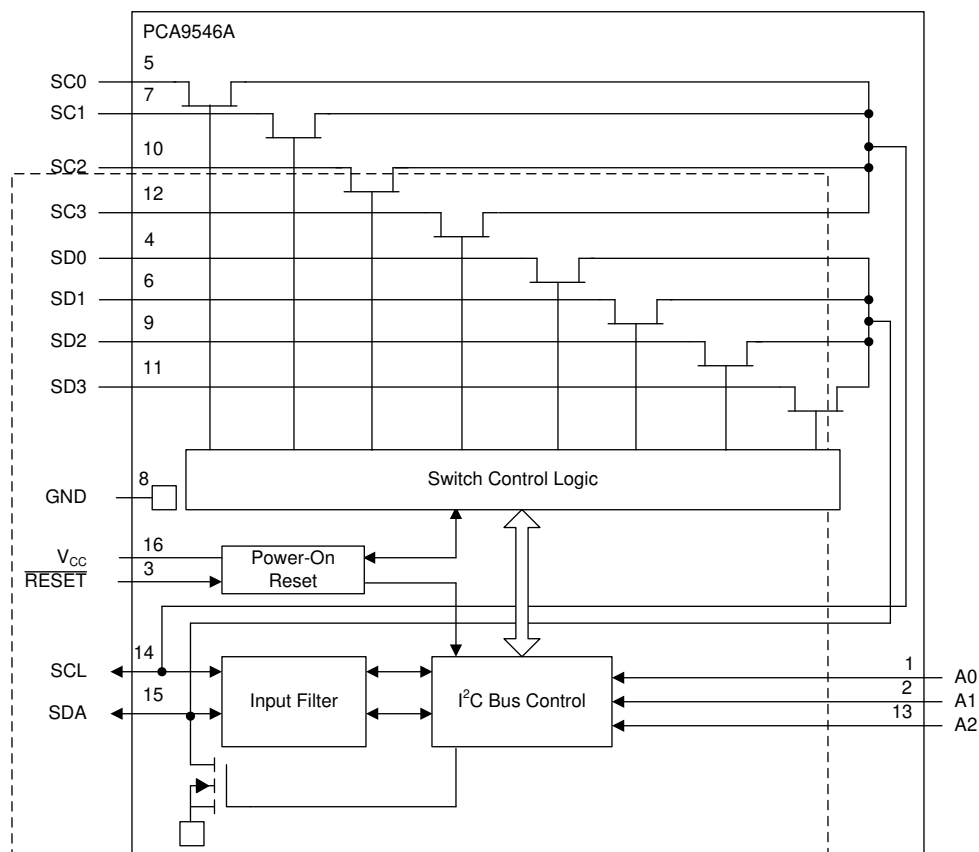

Copyright © 2016, Texas Instruments Incorporated

### 8.3 Feature Description

The PCA9546A is a 4-channel, bidirectional translating switch for I<sup>2</sup>C buses that supports Standard-Mode (100 kHz) and Fast-Mode (400 kHz) operation. The PCA9546A features I<sup>2</sup>C control using a single 8-bit control register in which the four least significant bits control the enabling and disabling of the 4 switch channels of I<sup>2</sup>C data flow. Depending on the application, voltage translation of the I<sup>2</sup>C bus can also be achieved using the PCA9546A to allow 1.8-V, 2.5-V, or 3.3-V parts to communicate with 5-V parts. Additionally, in the event that communication on the I<sup>2</sup>C bus enters a fault state, the PCA9546A can be reset to resume normal operation using the  $\overline{\text{RESET}}$  pin feature or by a power-on reset which results from cycling power to the device.

### 8.4 Device Functional Modes

#### 8.4.1 $\overline{\text{RESET}}$ Input

The  $\overline{\text{RESET}}$  input is an active-low signal that may be used to recover from a bus-fault condition. When this signal is asserted low for a minimum of  $t_{\text{WHL}}$ , the PCA9546A resets its registers and I<sup>2</sup>C state machine and deselects all channels. The  $\overline{\text{RESET}}$  input must be connected to  $V_{\text{CC}}$  through a pull-up resistor.

##### 8.4.1.1 $\overline{\text{RESET}}$ Errata

If  $\overline{\text{RESET}}$  voltage set higher than  $V_{\text{CC}}$ , current will flow from  $\overline{\text{RESET}}$  pin to  $V_{\text{CC}}$  pin.

#### System Impact

$V_{\text{CC}}$  will be pulled above its regular voltage level

#### System Workaround

Design such that  $\overline{\text{RESET}}$  voltage is same or lower than  $V_{\text{CC}}$

#### 8.4.2 Power-On Reset

When power is applied to  $V_{\text{CC}}$ , an internal power-on reset holds the PCA9546A in a reset condition until  $V_{\text{CC}}$  has reached  $V_{\text{POR}}$ . At this point, the reset condition is released, and the PCA9546A registers and I<sup>2</sup>C state machine are initialized to their default states, all zeroes, causing all the channels to be deselected. Thereafter,  $V_{\text{CC}}$  must be lowered below  $V_{\text{POR}}$  to reset the device.

### 8.5 Programming

#### 8.5.1 I<sup>2</sup>C Interface

The I<sup>2</sup>C bus is for two-way two-line communication between different ICs or modules. The two lines are a serial data line (SDA) and a serial clock line (SCL). Both lines must be connected to a positive supply via a pull-up resistor when connected to the output stages of a device. Data transfer can be initiated only when the bus is not busy.

One data bit is transferred during each clock pulse. The data on the SDA line must remain stable during the high period of the clock pulse, as changes in the data line at this time are interpreted as control signals (see [图 8-1](#)).



图 8-1. Bit Transfer

Both data and clock lines remain high when the bus is not busy. A high-to-low transition of the data line while the clock is high is defined as the start condition (S). A low-to-high transition of the data line while the clock is high is defined as the stop condition (P) (see [图 8-2](#)).

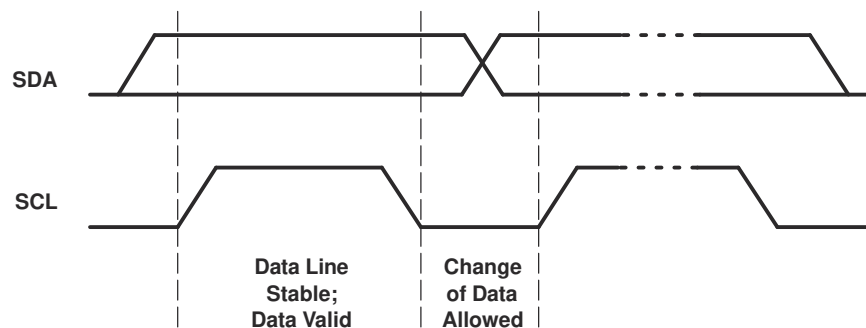
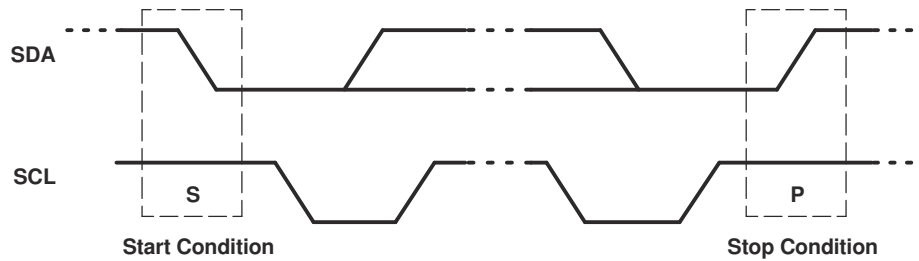

**图 8-2. Definition of Start and Stop Conditions**

A device generating a message is a transmitter; a device receiving is the receiver. The device that controls the message is the master, and the devices that are controlled by the master are the slaves (see [图 8-3](#)).

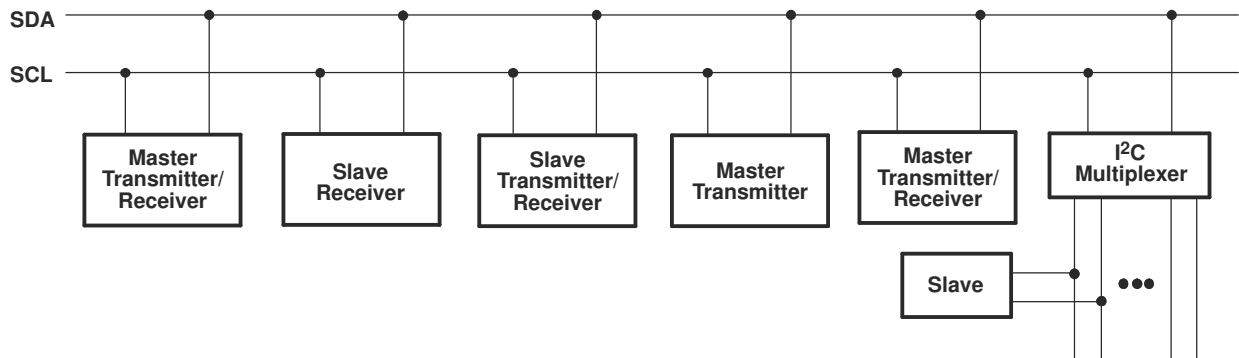

**图 8-3. System Configuration**

The number of data bytes transferred between the start and the stop conditions from transmitter to receiver is not limited. Each byte of eight bits is followed by one acknowledge (ACK) bit. The transmitter must release the SDA line before the receiver can send an ACK bit.

When a slave receiver is addressed, it must generate an ACK after the reception of each byte. Also, a master must generate an ACK after the reception of each byte that has been clocked out of the slave transmitter. The device that acknowledges must pull down the SDA line during the ACK clock pulse so that the SDA line is stable low during the high pulse of the ACK-related clock period (see [图 8-4](#)). Setup and hold times must be taken into account.



图 8-4. Acknowledgment on the I<sup>2</sup>C Bus

Data is transmitted to the PCA9546A control register using the write mode shown in 图 8-5.

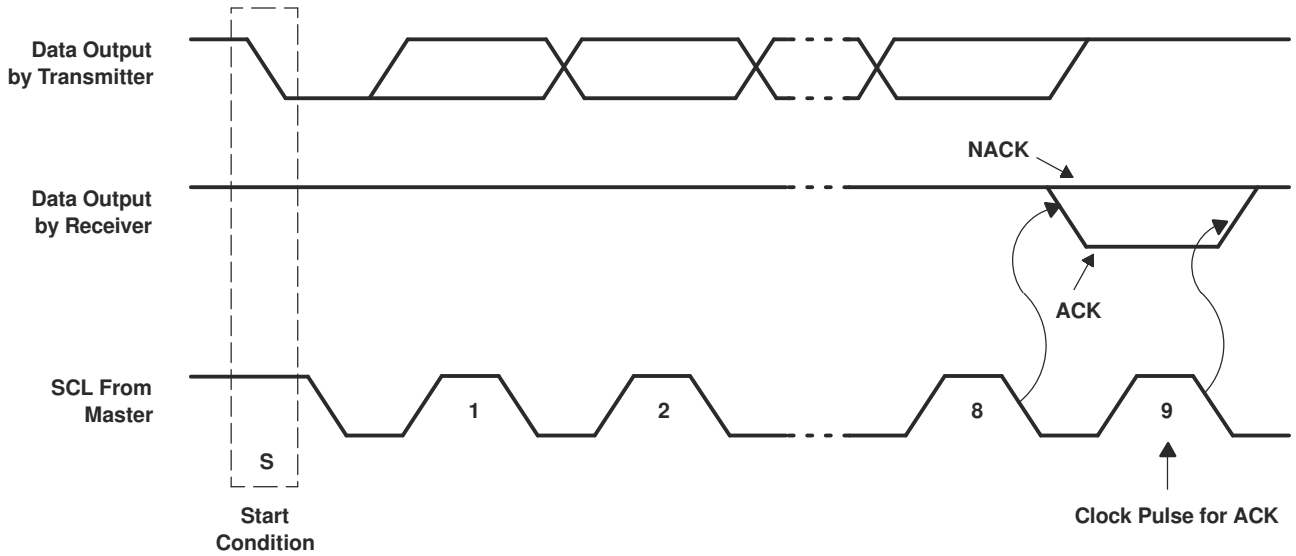

图 8-5. Write Control Register

Data is read from the PCA9546A control register using the read mode shown in 图 8-6.

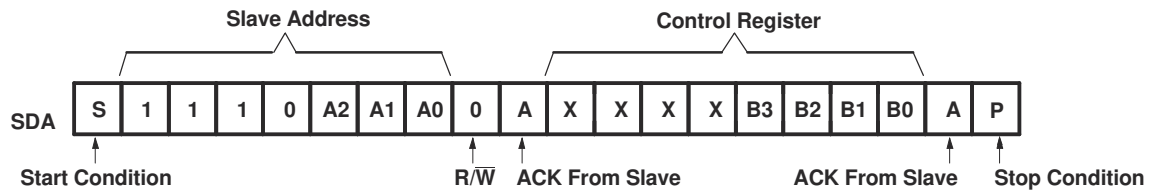

图 8-6. Read Control Register

## 8.6 Control Register

### 8.6.1 Device Address

Following a start condition, the bus master must output the address of the slave it is accessing. The address of the PCA9546A is shown in [图 8-7](#). To conserve power, no internal pull-up resistors are incorporated on the hardware-selectable address pins, and they must be pulled high or low.

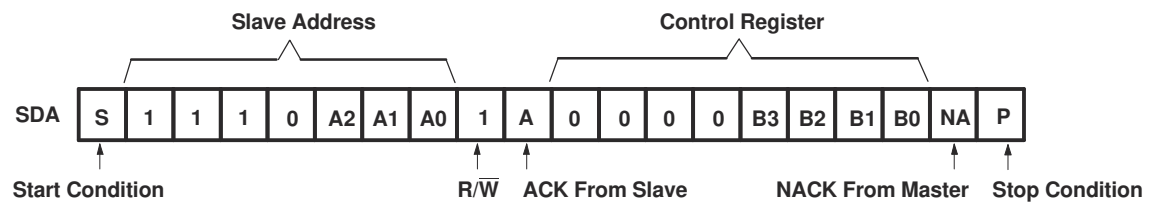

图 8-7. PCA9546A Address

The last bit of the slave address defines the operation to be performed. When set to a logic 1, a read is selected, while a logic 0 selects a write operation.

### 8.6.2 Control Register Description

Following the successful acknowledgment of the slave address, the bus master sends a byte to the PCA9546A, which is stored in the control register (see [图 8-8](#)). If multiple bytes are received by the PCA9546A, it will save the last byte received. This register can be written and read via the I<sup>2</sup>C bus.

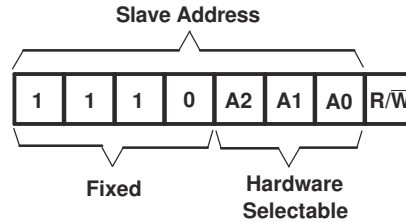

图 8-8. Control Register

### 8.6.3 Control Register Definition

One or several SCn/SDn downstream pairs, or channels, are selected by the contents of the control register (see [表 8-1](#)). This register is written after the PCA9546A has been addressed. The four LSBs of the control byte are used to determine which channel or channels are to be selected. When a channel is selected, the channel becomes active after a stop condition has been placed on the I<sup>2</sup>C bus. This ensures that all SCn/SDn lines are in a high state when the channel is made active, so that no false conditions are generated at the time of connection. A stop condition always must occur right after the acknowledge cycle.

**表 8-1. Control Register Write (Channel Selection), Control Register Read (Channel Status)<sup>(1)</sup>**

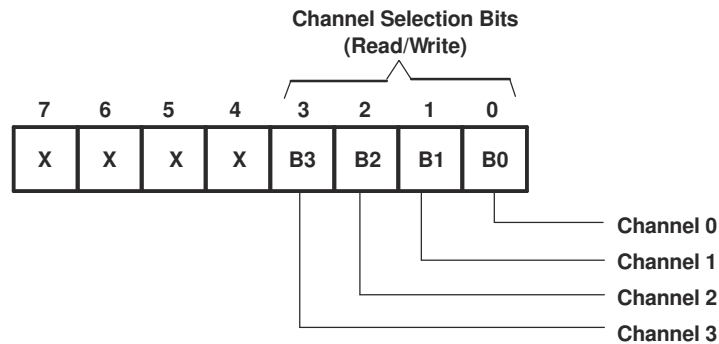
B7	B6	B5	B4	B3	B2	B1	B0	COMMAND
X	X	X	X	X	X	X	0	Channel 0 disabled
							1	Channel 0 enabled
X	X	X	X	X	X	X	0	Channel 1 disabled
							1	Channel 1 enabled
X	X	X	X	X	0	X	X	Channel 2 disabled
					1			Channel 2 enabled
X	X	X	X	0	X	X	X	Channel 3 disabled
				1				Channel 3 enabled
0	0	0	0	0	0	0	0	No channel selected, power-up/reset default state

- (1) Several channels can be enabled at the same time. For example, B3 = 0, B2 = 1, B1 = 1, B0 = 0 means that channels 0 and 3 are disabled, and channels 1 and 2 are enabled. Care must be taken not to exceed the maximum bus capacity.

## 9 Application Information Disclaimer

### 备注

以下应用部分中的信息不属于 TI 器件规格的范围，TI 不担保其准确性和完整性。TI 的客户应负责确定器件是否适用于其应用。客户应验证并测试其设计，以确保系统功能。

### 9.1 Application Information

Applications of the PCA9546A will contain an I<sup>2</sup>C (or SMBus) master device and up to four I<sup>2</sup>C slave devices. The downstream channels are ideally used to resolve I<sup>2</sup>C slave address conflicts. For example, if four identical digital temperature sensors are needed in the application, one sensor can be connected at each channel: 0, 1, 2, and 3. When the temperature at a specific location must be read, the appropriate channel can be enabled and all other channels switched off, the data can be retrieved, and the I<sup>2</sup>C master can move on and read the next channel.

In an application where the I<sup>2</sup>C bus will contain many additional slave devices that do not result in I<sup>2</sup>C slave address conflicts, these slave devices can be connected to any desired channel to distribute the total bus capacitance across multiple channels. If multiple switches will be enabled simultaneously, additional design requirements must be considered (See [Design Requirements](#) and [Detailed Design Procedure](#)).

### 9.2 Typical Application

A typical application of the PCA9546A will contain anywhere from 1 to 5 separate data pull-up voltages,  $V_{DPUX}$ , one for the master device ( $V_{DPU0}$ ) and one for each of the selectable slave channels ( $V_{DPU0}$  –  $V_{DPU3}$ ). In the event where the master device and all slave devices operate at the same voltage, then the pass voltage,  $V_{pass} = V_{DPUX}$ . Once the maximum  $V_{pass}$  is known,  $V_{CC}$  can be selected easily using [图 9-2](#). In an application where voltage translation is necessary, additional design requirements must be considered (See [Design Requirements](#)).

[图 9-1](#) shows an application in which the PCA9546A can be used.

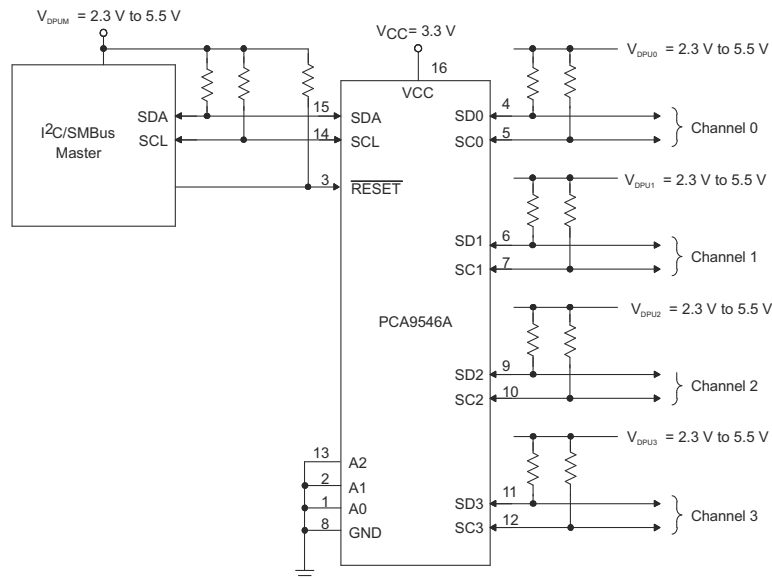

Copyright © 2016, Texas Instruments Incorporated

**图 9-1. PCA9546A Typical Application Schematic**



### 9.2.1 Design Requirements

The A0, A1, and A2 pins are hardware selectable to control the slave address of the PCA9546A. These pins may be tied directly to GND or  $V_{CC}$  in the application.

If multiple slave channels will be activated simultaneously in the application, then the total  $I_{OL}$  from SCL/SDA to GND on the master side will be the sum of the currents through all pull-up resistors,  $R_p$ .

The pass-gate transistors of the PCA9546A are constructed such that the  $V_{CC}$  voltage can be used to limit the maximum voltage that is passed from one I<sup>2</sup>C bus to another.

图 9-2 shows the voltage characteristics of the pass-gate transistors (note that the graph was generated using data specified in the [Electrical Characteristics](#) section of this data sheet). In order for the PCA9546A to act as a voltage translator, the  $V_{pass}$  voltage must be equal to or lower than the lowest bus voltage. For example, if the main bus is running at 5 V and the downstream buses are 3.3 V and 2.7 V,  $V_{pass}$  must be equal to or below 2.7 V to effectively clamp the downstream bus voltages. As shown in 图 9-2,  $V_{pass(max)}$  is 2.7 V when the PCA9546A supply voltage is 4 V or lower, so the PCA9546A supply voltage could be set to 3.3 V. Pull-up resistors then can be used to bring the bus voltages to their appropriate levels (see 图 9-1).

### 9.2.2 Detailed Design Procedure

Once all the slaves are assigned to the appropriate slave channels and bus voltages are identified, the pull-up resistors,  $R_p$ , for each of the buses need to be selected appropriately. The minimum pull-up resistance is a function of  $V_{DPUX}$ ,  $V_{OL(max)}$ , and  $I_{OL}$  as shown in 方程式 1:

$$R_{p(min)} = \frac{V_{DPUX} - V_{OL(max)}}{I_{OL}} \quad (1)$$

The maximum pull-up resistance is a function of the maximum rise time,  $t_r$  (300 ns for fast-mode operation,  $f_{SCL} = 400$  kHz) and bus capacitance,  $C_b$  as shown in 方程式 2:

$$R_{p(max)} = \frac{t_r}{0.8473 \times C_b} \quad (2)$$

The maximum bus capacitance for an I<sup>2</sup>C bus must not exceed 400 pF for fast-mode operation. The bus capacitance can be approximated by adding the capacitance of the PCA9546A,  $C_{iO(OFF)}$ , the capacitance of wires/connections/traces, and the capacitance of each individual slave on a given channel. If multiple channels will be activated simultaneously, each of the slaves on all channels will contribute to total bus capacitance.

### 9.2.3 Application Curves

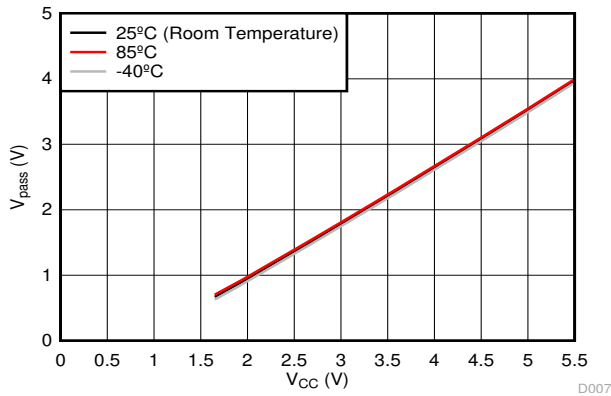

**图 9-2. Pass-Gate Voltage ( $V_{pass}$ ) vs Supply Voltage ( $V_{CC}$ ) at Three Temperature Points**

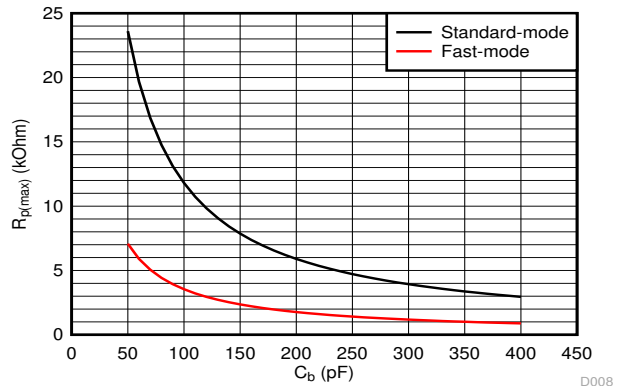

Standard-mode ( $f_{SCL} = 100$  kHz,  $t_r = 1$   $\mu$ s)      Fast-mode ( $f_{SCL} = 400$  kHz,  $t_r = 300$  ns)

**图 9-3. Maximum Pull-Up resistance ( $R_{p(max)}$ ) vs Bus Capacitance ( $C_b$ )**

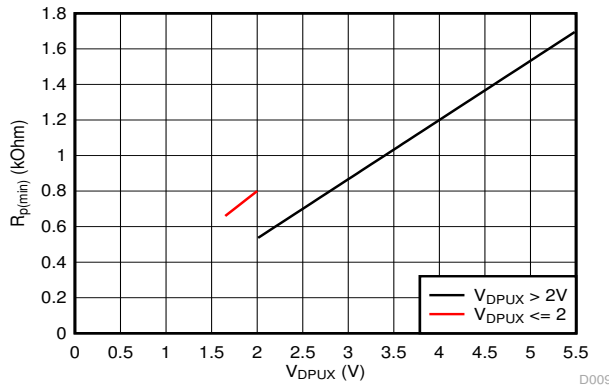

$V_{OL} = 0.2 \cdot V_{DPUX}$ ,  $I_{OL} = 2$  mA when  $V_{DPUX} \leq 2$  V

$V_{OL} = 0.4$  V,  $I_{OL} = 3$  mA when  $V_{DPUX} > 2$  V

**图 9-4. Minimum Pull-Up Resistance ( $R_{p(min)}$ ) vs Pull-Up Reference Voltage ( $V_{DPUX}$ )**

## 10 Power Supply Recommendations

### 10.1 Power-On Reset Requirements

In the event of a glitch or data corruption, PCA9546A can be reset to its default conditions by using the power-on reset feature. Power-on reset requires that the device go through a power cycle to be completely reset. This reset also happens when the device is powered on for the first time in an application.

The two types of power-on reset are shown in 图 10-1 and 图 10-2.



图 10-1.  $V_{CC}$  Is Lowered Below 0.2 V Or 0 V And Then Ramped Up To  $V_{CC}$



图 10-2.  $V_{CC}$  Is Lowered Below The Por Threshold, Then Ramped Back Up To  $V_{CC}$

表 10-1 specifies the performance of the power-on reset feature for PCA9546A for both types of power-on reset.

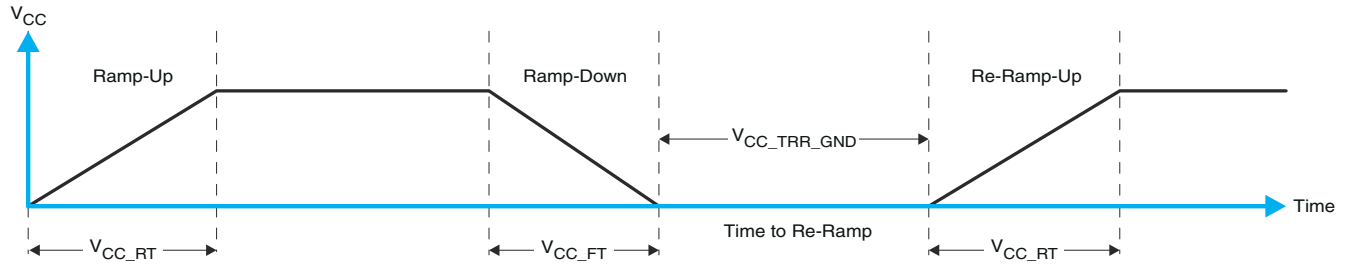
表 10-1. Recommended Supply Sequencing And Ramp Rates<sup>(1)</sup>

PARAMETER		MIN	TYP	MAX	UNIT
$V_{CC\_FT}$	Fall rate	See 图 10-1	1	100	ms
$V_{CC\_RT}$	Rise rate	See 图 10-1	0.01	100	ms
$V_{CC\_TRR\_GND}$	Time to re-ramp (when $V_{CC}$ drops to GND)	See 图 10-1	0.001		ms
$V_{CC\_TRR\_POR50}$	Time to re-ramp (when $V_{CC}$ drops to $V_{POR\_MIN} - 50$ mV)	See 图 10-2	0.001		ms
$V_{CC\_GH}$	Level that $V_{CCP}$ can glitch down to, but not cause a functional disruption when $V_{CCX\_GW} = 1 \mu s$	See 图 10-3		1.2	V
$V_{CC\_GW}$	Glitch width that will not cause a functional disruption when $V_{CCX\_GH} = 0.5 \times V_{CCX}$	See 图 10-3			$\mu s$
$V_{PORF}$	Voltage trip point of POR on falling $V_{CC}$		0.767	1.144	V
$V_{PORR}$	Voltage trip point of POR on rising $V_{CC}$		1.033	1.428	V

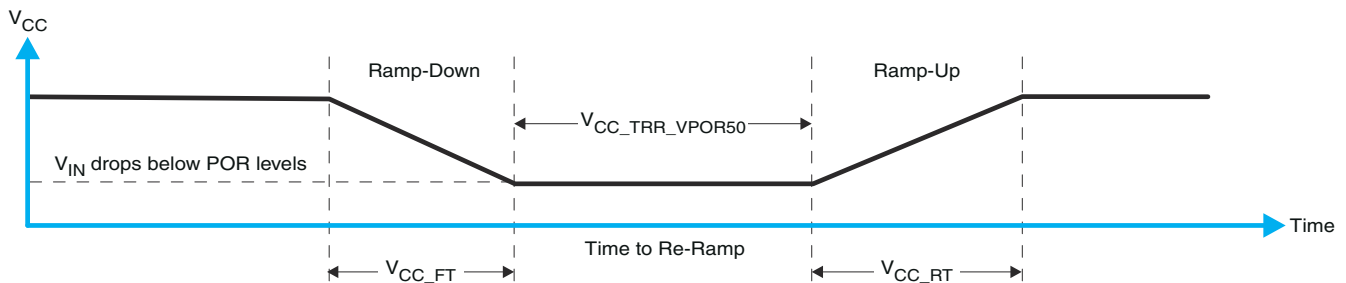
(1)  $T_A = -40^\circ\text{C}$  to  $85^\circ\text{C}$  (unless otherwise noted)

Glitches in the power supply can also affect the power-on reset performance of this device. The glitch width ( $V_{CC\_GW}$ ) and height ( $V_{CC\_GH}$ ) are dependent on each other. The bypass capacitance, source impedance, and the device impedance are factors that affect power-on reset performance. 图 10-3 and 表 10-1 provide more information on how to measure these specifications.



图 10-3. Glitch Width And Glitch Height

$V_{POR}$  is critical to the power-on reset.  $V_{POR}$  is the voltage level at which the reset condition is released and all the registers and the I<sup>2</sup>C/SMBus state machine are initialized to their default states. The value of  $V_{POR}$  differs based on the  $V_{CC}$  being lowered to or from 0. 图 10-4 和 表 10-1 提供更多信息。

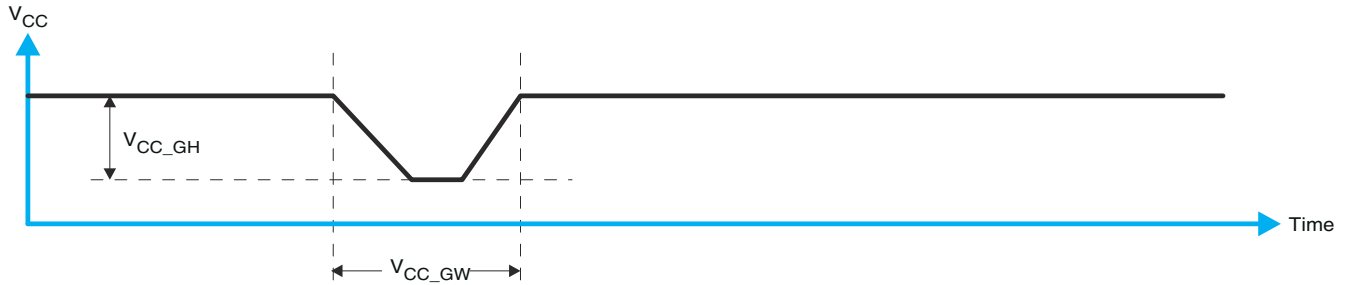

图 10-4.  $V_{POR}$

## 11 Layout

### 11.1 Layout Guidelines

For PCB layout of the PCA9546A, common PCB layout practices must be followed but additional concerns related to high-speed data transfer such as matched impedances and differential pairs are not a concern for I<sup>2</sup>C signal speeds. It is common to have a dedicated ground plane on an inner layer of the board and pins that are connected to ground must have a low-impedance path to the ground plane in the form of wide polygon pours and multiple vias. By-pass and de-coupling capacitors are commonly used to control the voltage on the V<sub>CC</sub> pin, using a larger capacitor to provide additional power in the event of a short power supply glitch and a smaller capacitor to filter out high-frequency ripple.

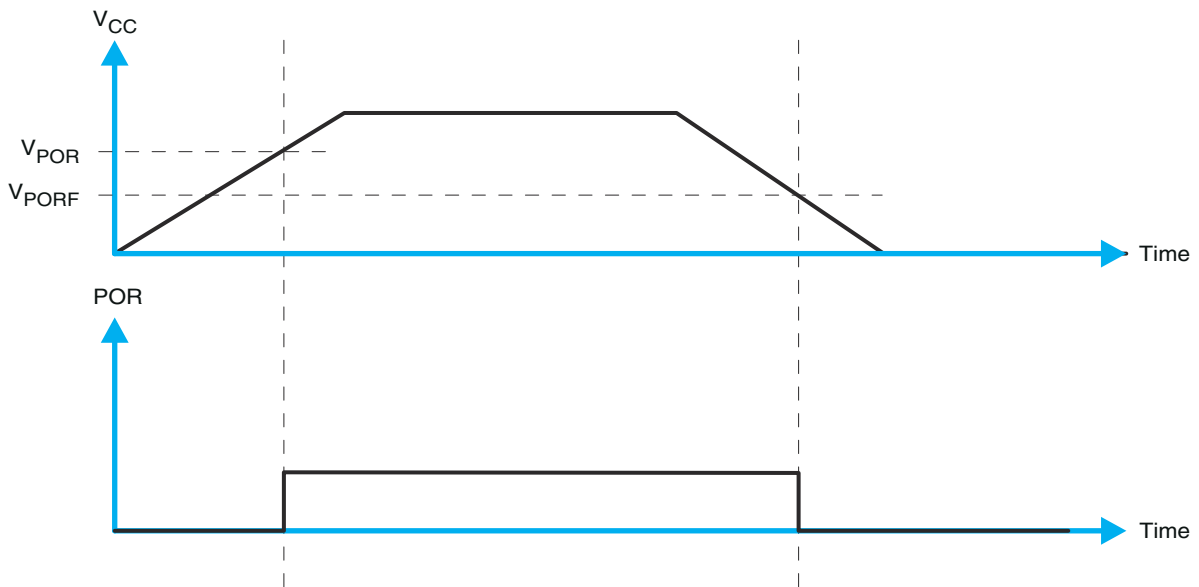
In an application where voltage translation is not required, all V<sub>DPUX</sub> voltages and V<sub>CC</sub> could be at the same potential and a single copper plane could connect all of pull-up resistors to the appropriate reference voltage. In an application where voltage translation is required, V<sub>DPUM</sub>, V<sub>DPU0</sub>, V<sub>DPU1</sub>, V<sub>DPU2</sub>, and V<sub>DPU3</sub> may all be on the same layer of the board with split planes to isolate different voltage potentials.

To reduce the total I<sup>2</sup>C bus capacitance added by PCB parasitics, data lines (SC<sub>n</sub> and SD<sub>n</sub>) must be as short as possible and the widths of the traces must also be minimized (e.g. 5-10 mils depending on copper weight).

### 11.2 Layout Example

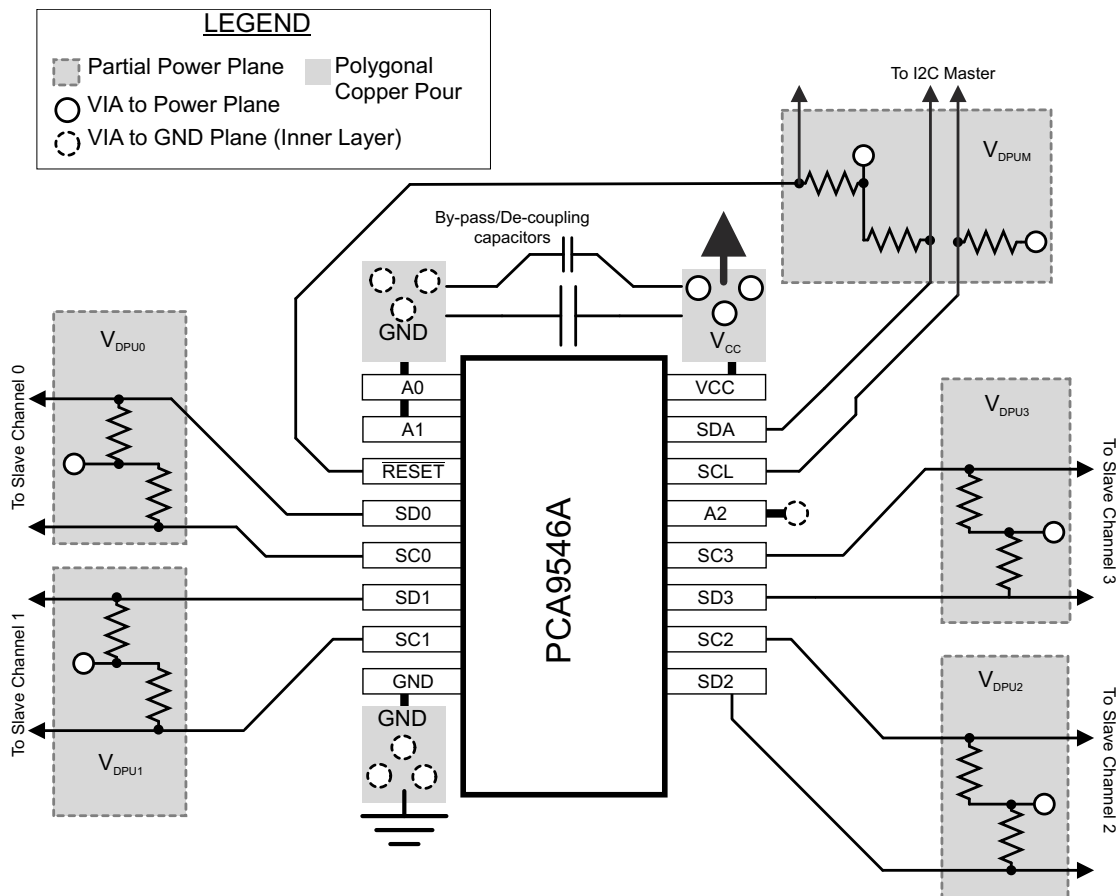

## 12 Device and Documentation Support

### 12.1 接收文档更新通知

要接收文档更新通知，请导航至 [ti.com](http://ti.com) 上的器件产品文件夹。点击 [订阅更新](#) 进行注册，即可每周接收产品信息更改摘要。有关更改的详细信息，请查看任何已修订文档中包含的修订历史记录。

### 12.2 支持资源

**TI E2E™ 支持论坛** 是工程师的重要参考资料，可直接从专家获得快速、经过验证的解答和设计帮助。搜索现有解答或提出自己的问题可获得所需的快速设计帮助。

链接的内容由各个贡献者“按原样”提供。这些内容并不构成 TI 技术规范，并且不一定反映 TI 的观点；请参阅 TI 的《[使用条款](#)》。

### 12.3 Trademarks

TI E2E™ is a trademark of Texas Instruments.

所有商标均为其各自所有者的财产。

### 12.4 Electrostatic Discharge Caution



This integrated circuit can be damaged by ESD. Texas Instruments recommends that all integrated circuits be handled with appropriate precautions. Failure to observe proper handling and installation procedures can cause damage.

ESD damage can range from subtle performance degradation to complete device failure. Precision integrated circuits may be more susceptible to damage because very small parametric changes could cause the device not to meet its published specifications.

### 12.5 术语表

**TI 术语表** 本术语表列出并解释了术语、首字母缩略词和定义。

## 13 Mechanical, Packaging, and Orderable Information

The following pages include mechanical, packaging, and orderable information. This information is the most current data available for the designated devices. This data is subject to change without notice and revision of this document. For browser-based versions of this data sheet, refer to the left-hand navigation

**PACKAGING INFORMATION**

Orderable Device	Status (1)	Package Type	Package Drawing	Pins	Package Qty	Eco Plan (2)	Lead finish/ Ball material (6)	MSL Peak Temp (3)	Op Temp (°C)	Device Marking (4/5)	Samples
PCA9546ADGVR	NRND	TVSOP	DGV	16	2000	RoHS & Green	NIPDAU	Level-1-260C-UNLIM	-40 to 85	PD546A	
PCA9546ADR	ACTIVE	SOIC	D	16	2500	RoHS & Green	NIPDAU	Level-1-260C-UNLIM	-40 to 85	PCA9546A	Samples
PCA9546ADW	NRND	SOIC	DW	16	40	RoHS & Green	NIPDAU	Level-1-260C-UNLIM	-40 to 85	PCA9546A	
PCA9546ADWR	NRND	SOIC	DW	16	2000	RoHS & Green	NIPDAU	Level-1-260C-UNLIM	-40 to 85	PCA9546A	
PCA9546APW	OBSOLETE	TSSOP	PW	16		TBD	Call TI	Call TI	-40 to 85	PD546A	
PCA9546APWR	ACTIVE	TSSOP	PW	16	2000	RoHS & Green	NIPDAU	Level-1-260C-UNLIM	-40 to 85	PD546A	Samples
PCA9546APWRE4	ACTIVE	TSSOP	PW	16	2000	RoHS & Green	NIPDAU	Level-1-260C-UNLIM	-40 to 85	PD546A	Samples
PCA9546APWRG4	ACTIVE	TSSOP	PW	16	2000	RoHS & Green	NIPDAU	Level-1-260C-UNLIM	-40 to 85	PD546A	Samples
PCA9546ARGVR	ACTIVE	VQFN	RGV	16	2500	RoHS & Green	NIPDAU	Level-2-260C-1 YEAR	-40 to 85	PD546A	Samples
PCA9546ARGYR	NRND	VQFN	RGY	16	3000	RoHS & Green	NIPDAU	Level-2-260C-1 YEAR	-40 to 85	PD546A	

(1) The marketing status values are defined as follows:

**ACTIVE:** Product device recommended for new designs.

**LIFEBUY:** TI has announced that the device will be discontinued, and a lifetime-buy period is in effect.

**NRND:** Not recommended for new designs. Device is in production to support existing customers, but TI does not recommend using this part in a new design.

**PREVIEW:** Device has been announced but is not in production. Samples may or may not be available.

**OBSOLETE:** TI has discontinued the production of the device.

(2) **RoHS:** TI defines "RoHS" to mean semiconductor products that are compliant with the current EU RoHS requirements for all 10 RoHS substances, including the requirement that RoHS substance do not exceed 0.1% by weight in homogeneous materials. Where designed to be soldered at high temperatures, "RoHS" products are suitable for use in specified lead-free processes. TI may reference these types of products as "Pb-Free".

**RoHS Exempt:** TI defines "RoHS Exempt" to mean products that contain lead but are compliant with EU RoHS pursuant to a specific EU RoHS exemption.

**Green:** TI defines "Green" to mean the content of Chlorine (Cl) and Bromine (Br) based flame retardants meet JS709B low halogen requirements of <=1000ppm threshold. Antimony trioxide based flame retardants must also meet the <=1000ppm threshold requirement.

(3) MSL, Peak Temp. - The Moisture Sensitivity Level rating according to the JEDEC industry standard classifications, and peak solder temperature.

(4) There may be additional marking, which relates to the logo, the lot trace code information, or the environmental category on the device.

<sup>(5)</sup> Multiple Device Markings will be inside parentheses. Only one Device Marking contained in parentheses and separated by a "~" will appear on a device. If a line is indented then it is a continuation of the previous line and the two combined represent the entire Device Marking for that device.

<sup>(6)</sup> Lead finish/Ball material - Orderable Devices may have multiple material finish options. Finish options are separated by a vertical ruled line. Lead finish/Ball material values may wrap to two lines if the finish value exceeds the maximum column width.

**Important Information and Disclaimer:**The information provided on this page represents TI's knowledge and belief as of the date that it is provided. TI bases its knowledge and belief on information provided by third parties, and makes no representation or warranty as to the accuracy of such information. Efforts are underway to better integrate information from third parties. TI has taken and continues to take reasonable steps to provide representative and accurate information but may not have conducted destructive testing or chemical analysis on incoming materials and chemicals. TI and TI suppliers consider certain information to be proprietary, and thus CAS numbers and other limited information may not be available for release.

In no event shall TI's liability arising out of such information exceed the total purchase price of the TI part(s) at issue in this document sold by TI to Customer on an annual basis.



**TAPE AND REEL INFORMATION**

**QUADRANT ASSIGNMENTS FOR PIN 1 ORIENTATION IN TAPE**

\*All dimensions are nominal

Device	Package Type	Package Drawing	Pins	SPQ	Reel Diameter (mm)	Reel Width W1 (mm)	A0 (mm)	B0 (mm)	K0 (mm)	P1 (mm)	W (mm)	Pin1 Quadrant
PCA9546ADGVR	TVSOP	DGV	16	2000	330.0	12.4	6.8	4.0	1.6	8.0	12.0	Q1
PCA9546ADR	SOIC	D	16	2500	330.0	16.4	6.5	10.3	2.1	8.0	16.0	Q1
PCA9546ADWR	SOIC	DW	16	2000	330.0	16.4	10.75	10.7	2.7	12.0	16.0	Q1
PCA9546ARGYR	VQFN	RGY	16	3000	330.0	12.4	3.8	4.3	1.5	8.0	12.0	Q1

**TAPE AND REEL BOX DIMENSIONS**

\*All dimensions are nominal

Device	Package Type	Package Drawing	Pins	SPQ	Length (mm)	Width (mm)	Height (mm)
PCA9546ADGVR	TVSOP	DGV	16	2000	356.0	356.0	35.0
PCA9546ADR	SOIC	D	16	2500	356.0	356.0	35.0
PCA9546ADWR	SOIC	DW	16	2000	350.0	350.0	43.0
PCA9546ARGYR	VQFN	RGY	16	3000	356.0	356.0	35.0

**TUBE**

\*All dimensions are nominal

Device	Package Name	Package Type	Pins	SPQ	L (mm)	W (mm)	T (μm)	B (mm)
PCA9546ADW	DW	SOIC	16	40	506.98	12.7	4826	6.6

## GENERIC PACKAGE VIEW

**RGV 16**

**VQFN - 1 mm max height**

4 x 4, 0.65 mm pitch

PLASTIC QUAD FLATPACK - NO LEAD



Images above are just a representation of the package family, actual package may vary.  
Refer to the product data sheet for package details.

4224748/A

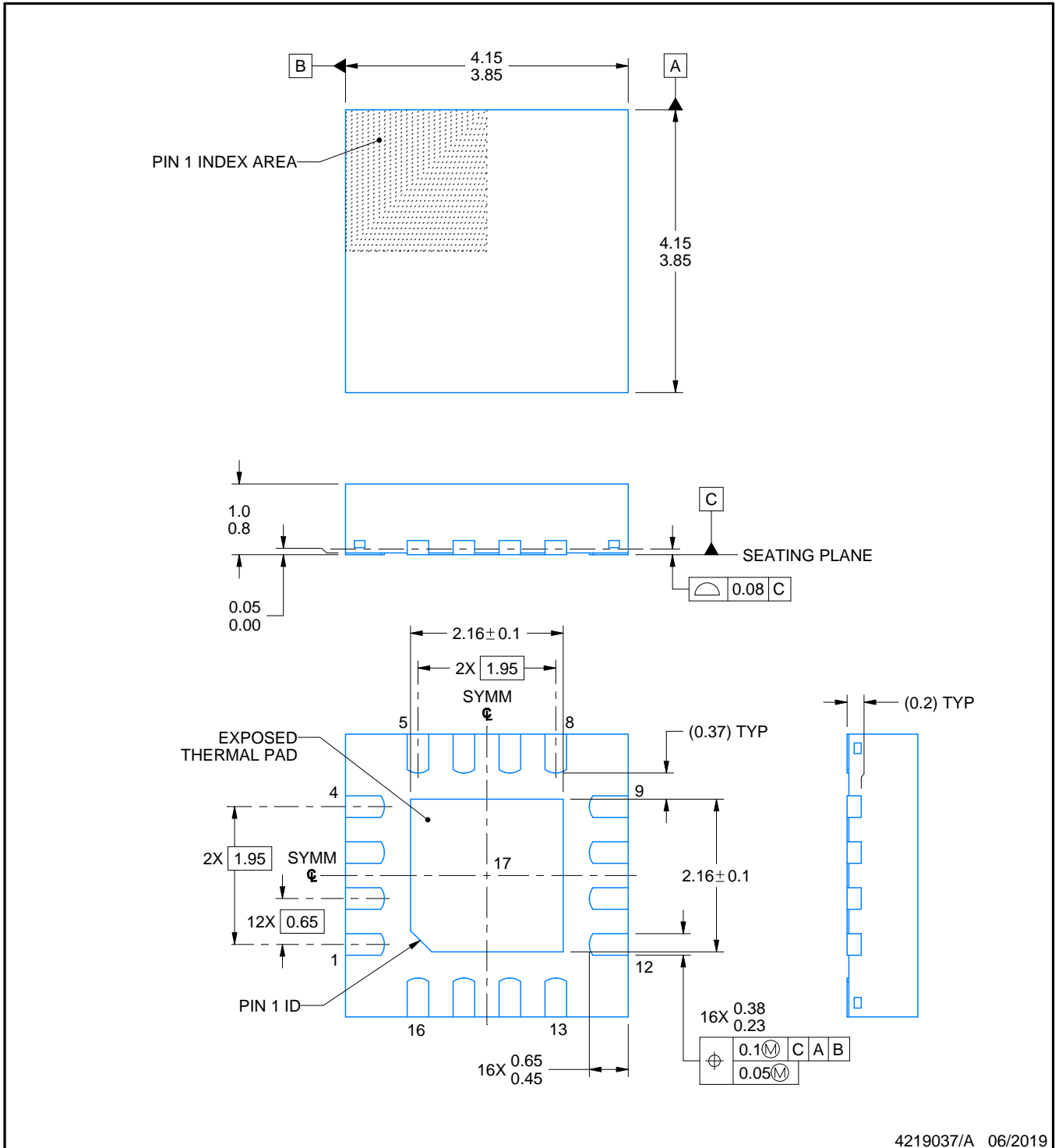
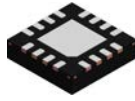

NOTES:

1. All linear dimensions are in millimeters. Any dimensions in parenthesis are for reference only. Dimensioning and tolerancing per ASME Y14.5M.
2. This drawing is subject to change without notice.
3. The package thermal pad must be soldered to the printed circuit board for thermal and mechanical performance.

# EXAMPLE BOARD LAYOUT

RGV0016A

VQFN - 1 mm max height

PLASTIC QUAD FLATPACK - NO LEAD

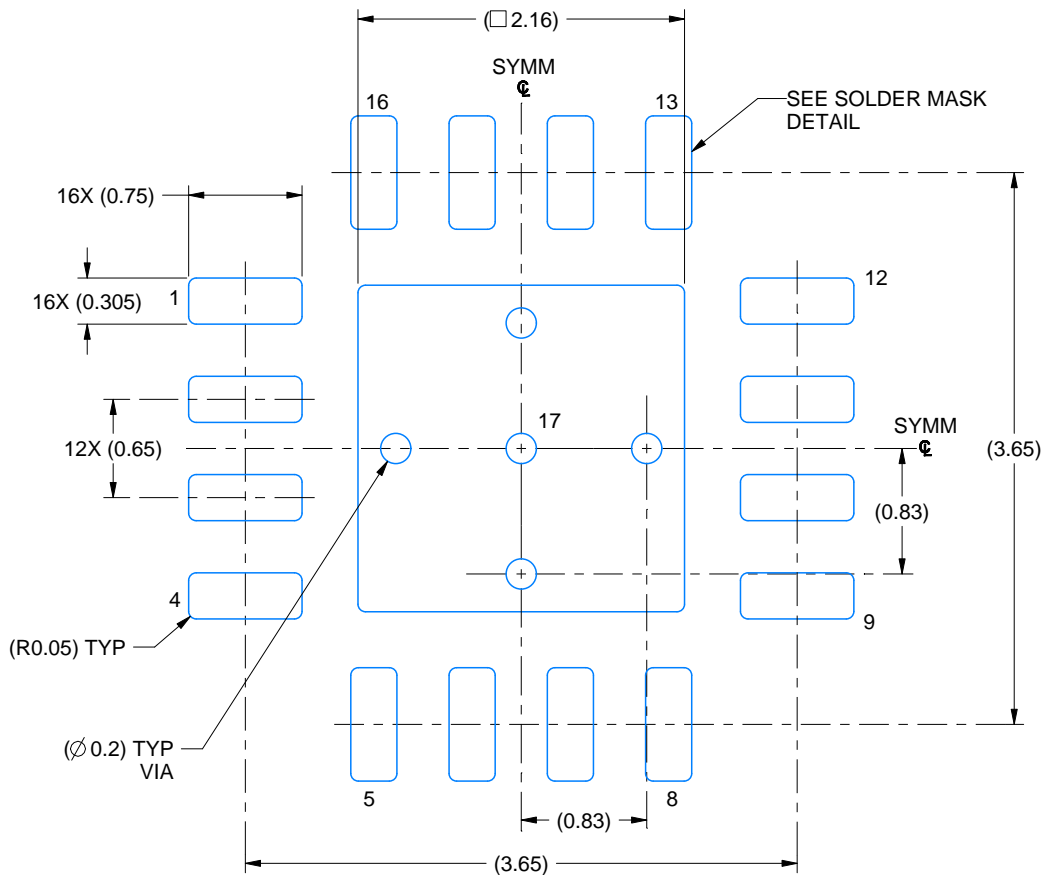

LAND PATTERN EXAMPLE  
EXPOSED METAL SHOWN  
SCALE: 20X



4219037/A 06/2019

NOTES: (continued)

- This package is designed to be soldered to a thermal pad on the board. For more information, see Texas Instruments literature number SLUA271 ([www.ti.com/lit/slua271](http://www.ti.com/lit/slua271)).
- Vias are optional depending on application, refer to device data sheet. If any vias are implemented, refer to their locations shown on this view. It is recommended that vias under paste be filled, plugged or tented.

# EXAMPLE STENCIL DESIGN

RGV0016A

VQFN - 1 mm max height

PLASTIC QUAD FLATPACK - NO LEAD



SOLDER PASTE EXAMPLE  
BASED ON 0.125 MM THICK STENCIL  
SCALE: 20X

EXPOSED PAD 17  
79% PRINTED SOLDER COVERAGE BY AREA UNDER PACKAGE

4219037/A 06/2019

NOTES: (continued)

6. Laser cutting apertures with trapezoidal walls and rounded corners may offer better paste release. IPC-7525 may have alternate design recommendations.

D (R-PDSO-G16)

PLASTIC SMALL OUTLINE



- NOTES:
- A. All linear dimensions are in inches (millimeters).
  - B. This drawing is subject to change without notice.
  - C. Body length does not include mold flash, protrusions, or gate burrs. Mold flash, protrusions, or gate burrs shall not exceed 0.006 (0,15) each side.
  - D. Body width does not include interlead flash. Interlead flash shall not exceed 0.017 (0,43) each side.
  - E. Reference JEDEC MS-012 variation AC.





4220204/A 02/2017

NOTES:

1. All linear dimensions are in millimeters. Any dimensions in parenthesis are for reference only. Dimensioning and tolerancing per ASME Y14.5M.
2. This drawing is subject to change without notice.
3. This dimension does not include mold flash, protrusions, or gate burrs. Mold flash, protrusions, or gate burrs shall not exceed 0.15 mm per side.
4. This dimension does not include interlead flash. Interlead flash shall not exceed 0.25 mm per side.
5. Reference JEDEC registration MO-153.

# EXAMPLE BOARD LAYOUT

PW0016A

TSSOP - 1.2 mm max height

SMALL OUTLINE PACKAGE



LAND PATTERN EXAMPLE  
EXPOSED METAL SHOWN  
SCALE: 10X



SOLDER MASK DETAILS

4220204/A 02/2017

NOTES: (continued)

- 6. Publication IPC-7351 may have alternate designs.
- 7. Solder mask tolerances between and around signal pads can vary based on board fabrication site.

# EXAMPLE STENCIL DESIGN

PW0016A

TSSOP - 1.2 mm max height

SMALL OUTLINE PACKAGE



SOLDER PASTE EXAMPLE  
BASED ON 0.125 mm THICK STENCIL  
SCALE: 10X

4220204/A 02/2017

NOTES: (continued)

8. Laser cutting apertures with trapezoidal walls and rounded corners may offer better paste release. IPC-7525 may have alternate design recommendations.
9. Board assembly site may have different recommendations for stencil design.

## GENERIC PACKAGE VIEW

**DW 16**

**SOIC - 2.65 mm max height**

7.5 x 10.3, 1.27 mm pitch

SMALL OUTLINE INTEGRATED CIRCUIT

This image is a representation of the package family, actual package may vary.  
Refer to the product data sheet for package details.



4224780/A



DW0016A

# PACKAGE OUTLINE

SOIC - 2.65 mm max height

SOIC

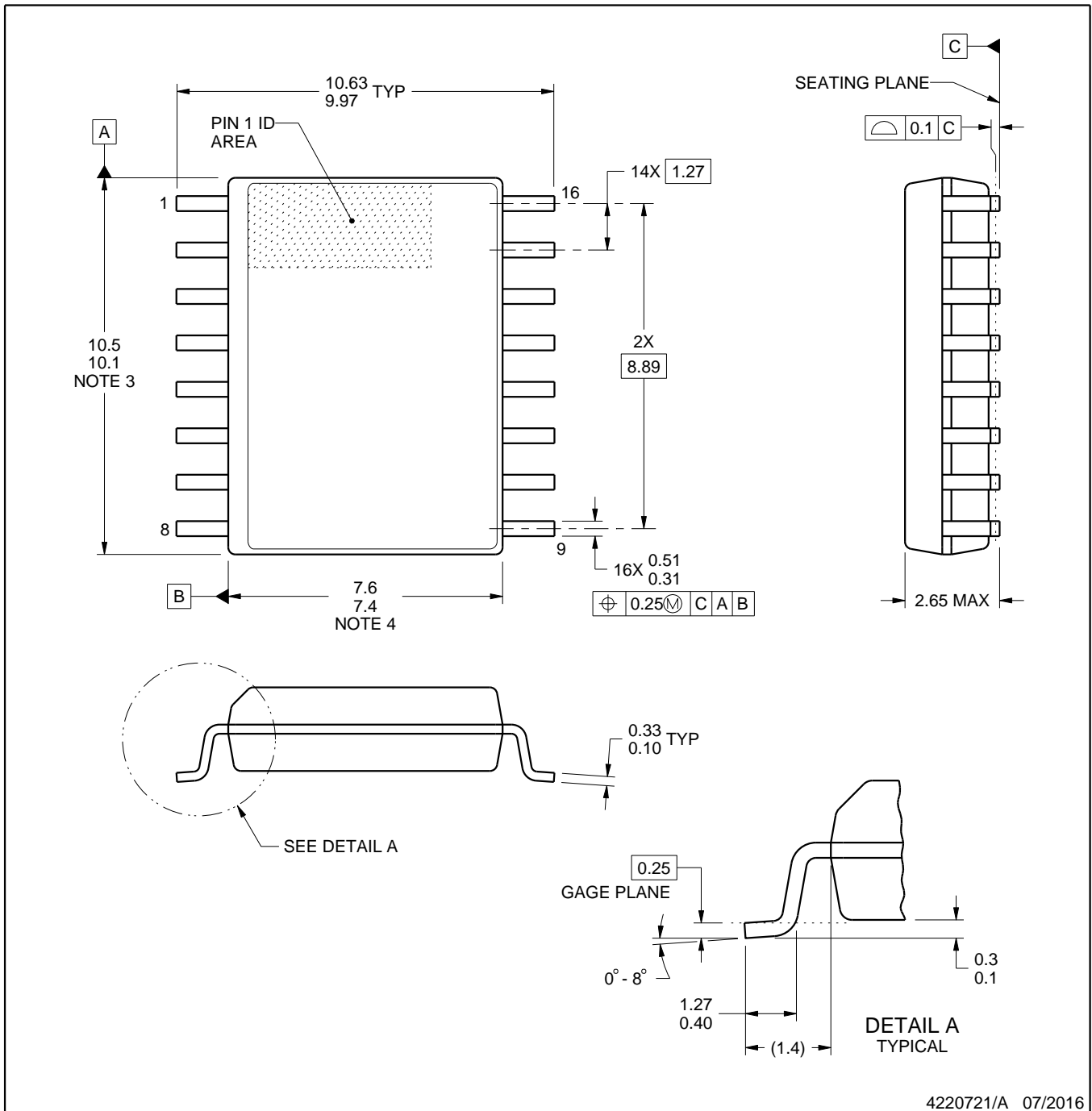

4220721/A 07/2016

NOTES:

1. All linear dimensions are in millimeters. Dimensions in parenthesis are for reference only. Dimensioning and tolerancing per ASME Y14.5M.
2. This drawing is subject to change without notice.
3. This dimension does not include mold flash, protrusions, or gate burrs. Mold flash, protrusions, or gate burrs shall not exceed 0.15 mm, per side.
4. This dimension does not include interlead flash. Interlead flash shall not exceed 0.25 mm, per side.
5. Reference JEDEC registration MS-013.

# EXAMPLE BOARD LAYOUT

DW0016A

SOIC - 2.65 mm max height

SOIC



LAND PATTERN EXAMPLE  
SCALE:7X



SOLDER MASK DETAILS

4220721/A 07/2016

NOTES: (continued)

6. Publication IPC-7351 may have alternate designs.

7. Solder mask tolerances between and around signal pads can vary based on board fabrication site.

# EXAMPLE STENCIL DESIGN

DW0016A

SOIC - 2.65 mm max height

SOIC



SOLDER PASTE EXAMPLE  
BASED ON 0.125 mm THICK STENCIL  
SCALE:7X

4220721/A 07/2016

NOTES: (continued)

8. Laser cutting apertures with trapezoidal walls and rounded corners may offer better paste release. IPC-7525 may have alternate design recommendations.
9. Board assembly site may have different recommendations for stencil design.

RGY (R-PVQFN-N16)

PLASTIC QUAD FLATPACK NO-LEAD



- NOTES:
- A. All linear dimensions are in millimeters. Dimensioning and tolerancing per ASME Y14.5M-1994.
  - B. This drawing is subject to change without notice.
  - C. QFN (Quad Flatpack No-Lead) package configuration.
  - D. The package thermal pad must be soldered to the board for thermal and mechanical performance.
  - E. See the additional figure in the Product Data Sheet for details regarding the exposed thermal pad features and dimensions.
  - F. Pin 1 identifiers are located on both top and bottom of the package and within the zone indicated. The Pin 1 identifiers are either a molded, marked, or metal feature.
  - G. Package complies to JEDEC MO-241 variation BA.



RGY (R-PVQFN-N16)

PLASTIC QUAD FLATPACK NO-LEAD

**THERMAL INFORMATION**

This package incorporates an exposed thermal pad that is designed to be attached directly to an external heatsink. The thermal pad must be soldered directly to the printed circuit board (PCB). After soldering, the PCB can be used as a heatsink. In addition, through the use of thermal vias, the thermal pad can be attached directly to the appropriate copper plane shown in the electrical schematic for the device, or alternatively, can be attached to a special heatsink structure designed into the PCB. This design optimizes the heat transfer from the integrated circuit (IC).

For information on the Quad Flatpack No-Lead (QFN) package and its advantages, refer to Application Report, QFN/SON PCB Attachment, Texas Instruments Literature No. SLUA271. This document is available at [www.ti.com](http://www.ti.com).

The exposed thermal pad dimensions for this package are shown in the following illustration.



Bottom View

Exposed Thermal Pad Dimensions

4206353-3/P 03/14

NOTE: All linear dimensions are in millimeters

RGY (R-PVQFN-N16)

PLASTIC QUAD FLATPACK NO-LEAD



4208122-3/P 03/14

- NOTES:
- A. All linear dimensions are in millimeters.
  - B. This drawing is subject to change without notice.
  - C. Publication IPC-7351 is recommended for alternate designs.
  - D. This package is designed to be soldered to a thermal pad on the board. Refer to Application Note, Quad Flat-Pack QFN/SON PCB Attachment, Texas Instruments Literature No. SLUA271, and also the Product Data Sheets for specific thermal information, via requirements, and recommended board layout. These documents are available at [www.ti.com](http://www.ti.com) <<http://www.ti.com>>.
  - E. Laser cutting apertures with trapezoidal walls and also rounding corners will offer better paste release. Customers should contact their board assembly site for stencil design recommendations. Refer to IPC 7525 for stencil design considerations.
  - F. Customers should contact their board fabrication site for minimum solder mask web tolerances between signal pads.

## 重要声明和免责声明

TI“按原样”提供技术和可靠性数据（包括数据表）、设计资源（包括参考设计）、应用或其他设计建议、网络工具、安全信息和其他资源，不保证没有瑕疵且不做任何明示或暗示的担保，包括但不限于对适销性、某特定用途方面的适用性或不侵犯任何第三方知识产权的暗示担保。

这些资源可供使用 TI 产品进行设计的熟练开发人员使用。您将自行承担以下全部责任：(1) 针对您的应用选择合适的 TI 产品，(2) 设计、验证并测试您的应用，(3) 确保您的应用满足相应标准以及任何其他功能安全、信息安全、监管或其他要求。

这些资源如有变更，恕不另行通知。TI 授权您仅可将这些资源用于研发本资源所述的 TI 产品的应用。严禁对这些资源进行其他复制或展示。您无权使用任何其他 TI 知识产权或任何第三方知识产权。您应全额赔偿因在这些资源的使用中对 TI 及其代表造成的任何索赔、损害、成本、损失和债务，TI 对此概不负责。

TI 提供的产品受 [TI 的销售条款](#) 或 [ti.com](#) 上其他适用条款/TI 产品随附的其他适用条款的约束。TI 提供这些资源并不会扩展或以其他方式更改 TI 针对 TI 产品发布的适用的担保或担保免责声明。

TI 反对并拒绝您可能提出的任何其他或不同的条款。

邮寄地址：Texas Instruments, Post Office Box 655303, Dallas, Texas 75265

Copyright © 2024，德州仪器 (TI) 公司