

SN74ACT564 具有三态输出的八路边沿触发式 D 型触发器

1 特性

- 工作范围为 4.5V 至 5.5V V_{CC}
- 输入电压高达 5.5V
- 电压为 5V 时, t_{pd} 最大值为 8.5ns
- 输入兼容 TTL 电压
- 三态反相输出直接驱动总线
- 采用直通架构来优化 PCB 布局
- 针对负载的完全并行访问

2 说明

ACT564 器件是八路边沿触发式 D 类触发器, 具有专门设计用于驱动高容性或较低阻抗负载的三态输出。它们尤其适用于实现缓冲寄存器、I/O 端口、双向总线驱动器和工作寄存器。

封装信息

器件型号	封装 ⁽¹⁾	封装尺寸 ⁽²⁾	封装尺寸 ⁽³⁾
SN74ACT564	DW (SOIC , 20)	12.8mm × 10.3mm	12.8mm × 7.5mm
	N (PDIP , 20)	24.33mm × 9.4mm	24.33mm × 6.35mm
	NS (SOP , 20)	12.6mm × 7.8mm	12.6mm × 5.3mm
	PW (TSSOP , 20)	6.5mm × 6.4mm	6.5mm × 4.4mm

- (1) 更多相关信息, 请参阅第 10 节。
- (2) 封装尺寸 (长 × 宽) 为标称值, 并包括引脚 (如适用)。
- (3) 封装尺寸 (长 × 宽) 为标称值, 不包括引脚。

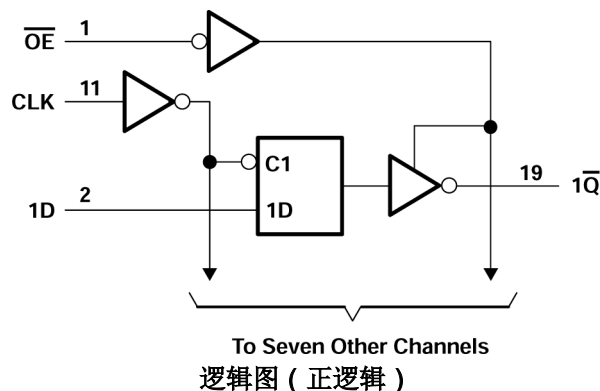

Table of Contents

1 特性	1	6.3 Device Functional Modes.....	8
2 说明	1	7 Application and Implementation	9
3 Pin Configuration and Functions	3	7.1 Power Supply Recommendations.....	9
4 Specifications	4	7.2 Layout.....	9
4.1 绝对最大额定值.....	4	8 Device and Documentation Support	10
4.2 Recommended Operating Conditions.....	4	8.1 Documentation Support (Analog).....	10
4.3 Thermal Information.....	4	8.2 接收文档更新通知.....	10
4.4 Electrical Characteristics.....	5	8.3 支持资源.....	10
4.5 Timing Requirements.....	5	8.4 Trademarks.....	10
4.6 Switching Characteristics.....	6	8.5 静电放电警告.....	10
4.7 Operating Characteristics.....	6	8.6 术语表.....	10
5 Parameter Measurement Information	7	9 Revision History	11
6 Detailed Description	8	10 Mechanical, Packaging, and Orderable Information	11
6.1 Overview.....	8		
6.2 Functional Block Diagram.....	8		

3 Pin Configuration and Functions



图 3-1. SN74ACT564 DB, DW, N, NS, or PW Package (Top View)

表 3-1. Pin Functions

PIN		TYPE	Description
NO.	NAME		
1	\overline{OE}	I	Clear all channels, active low
2	1D	I	Channel 1, D input
3	2D	I	Channel 2, D input
4	3D	I	Channel 3, D input
5	4D	I	Channel 4, D input
6	5D	I	Channel 5, D input
7	6D	I	Channel 6, D input
8	7D	I	Channel 7, D input
9	8D	I	Channel 8, D input
10	GND	—	Ground
11	CLK	I	Clock Pin
12	8Q	O	Channel 8, Q output
13	7Q	O	Channel 7, Q output
14	6Q	O	Channel 6, Q output
15	5Q	O	Channel 5, Q output
16	4Q	O	Channel 4, Q output
17	3Q	O	Channel 3, Q output
18	2Q	O	Channel 2, Q output
19	1Q	O	Channel 1, Q output
20	V _{CC}	—	Power Pin

4 Specifications

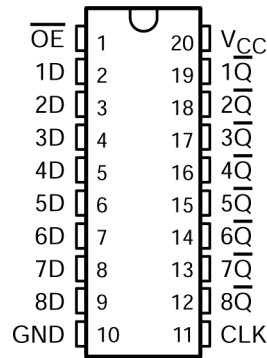
4.1 绝对最大额定值

在自然通风条件下的工作温度范围内测得（除非另有说明）⁽¹⁾

		最小值	最大值	单位
V _{CC}	电源电压范围	-0.5	7	V
V _I ⁽²⁾	输入电压范围	-0.5	V _{CC} +0.5	V
V _O ⁽²⁾	输出电压范围	-0.5	V _{CC} +0.5	V
I _{IK}	输入钳位电流	(V _I < 0 或 V _I > V _{CC})		±20 mA
I _{OK}	输出钳位电流	(V _O < 0 或 V _O > V _{CC})		±20 mA
I _O	持续输出电流	(V _O = 0 至 V _{CC})		±50 mA
通过 V _{CC} 或 GND 的持续电流				±200 mA
T _{stg}	贮存温度范围	-65	150	°C

- (1) 应力超出“绝对最大额定值”下列出的值可能会对器件造成永久损坏。这些仅为在应力额定值下的工作情况，对于额定值下的器件的功能性操作或者在超出“推荐的操作条件”下的任何其它情况，在此并未说明。长时间处于绝对最大额定条件下可能会影响器件的可靠性。
- (2) 如果遵守输入和输出电流额定值，输入和输出电压可超过额定值。

4.2 Recommended Operating Conditions

(over operating free-air temperature range (unless otherwise noted))⁽¹⁾

		SN74ACT564		UNIT
		MIN	MAX	
V _{CC}	Supply voltage	4.5	5.5	V
V _{IH}	High-level input voltage	2		V
V _{IL}	Low-level input voltage		0.8	V
V _I	Input voltage	0	V _{CC}	V
V _O	Output voltage	0	V _{CC}	V
I _{OH}	High-level output current		-24	mA
I _{OL}	Low-level output current		24	mA
Δt/Δv	Input transition rise or fall rate		8	ns/V
T _A	Operating free-air temperature	-40	85	°C

- (1) All unused inputs of the device must be held at V_{CC} or GND for proper device operation. Refer to the TI application report *Implications of Slow or Floating CMOS Inputs*, literature number SCBA004.

4.3 Thermal Information

THERMAL METRIC ⁽¹⁾	SN74ACT564					UNIT	
	DB (SSOP)	DW (SOIC)	N (PDIP)	NS (SO)	PW (TSSOP)		
	20 PINS	20 PINS	20 PINS	20 PINS	20 PINS		
R _{θJA}	Junction-to-ambient thermal resistance	70	101.2	69	106.2	126.2	°C/W

- (1) For more information about traditional and new thermal metrics, see the *IC Package Thermal Metrics* application report (SPRA953).

4.4 Electrical Characteristics

over recommended operating free-air temperature range (unless otherwise noted)

PARAMETER	TEST CONDITIONS	V _{CC}	T _A = 25°C			SN74ACT564		UNIT
			MIN	TYP	MAX	MIN	MAX	
V _{OH}	I _{OH} = - 50 μA	4.5 V	4.4	4.49		4.4	V	
		5.5 V	5.4	5.49		5.4		
	I _{OH} = - 24 mA	4.5 V				3.76		
		5.5 V				4.76		
	I _{OH} = - 50 mA ⁽¹⁾	5.5 V						
I _{OH} = - 75 mA ⁽¹⁾	5.5 V				3.85			
V _{OL}	I _{OL} = 50μA	4.5 V				0.1	V	
		5.5 V				0.1		
	I _{OL} = 24 mA	4.5 V				0.36		
		5.5 V				0.36		
	I _{OL} = 50 mA ⁽¹⁾	5.5 V						
I _{OL} = 75 mA ⁽¹⁾	5.5 V				1.65			
I _{OZ}	V _O = V _{CC} or GND	5.5 V			±0.25	±2.5	μA	
I _I	V _I = V _{CC} or GND	5.5 V			±0.1	±1	μA	
I _{CC}	V _I = V _{CC} or GND, I _O = 0	5.5 V			4	40	μA	
ΔI _{CC} ⁽²⁾	One input at 3.4 V, Other inputs at GND or V _{CC}	5.5 V		0.6		1.5	mA	
C _i	V _I = V _{CC} or GND	5 V		4.5			pF	
C _o	V _O = V _{CC} or GND	5 V		15			pF	

- (1) Not more than one output should be tested at a time, and the duration of the test should not exceed 2 ms.
- (2) This is the increase in supply current for each input that is at one of the specified TTL voltage levels, rather than 0 V or V_{CC}.

4.5 Timing Requirements

over recommended operating free-air temperature range, V_{CC} = 5 V ± 0.5 V (unless otherwise noted) (see [Load Circuit and Voltage Waveforms](#))

		T _A = 25°C		SN74ACT564		UNIT
		MIN	MAX	MIN	MAX	
f _{clock}	Clock frequency		85		75	MHz
t _w	Pulse duration, CLK high or low	3		3.5		ns
t _{su}	Setup time, data before CLK ↑	2.5		3		ns
t _h	Hold time, data after CLK ↑	1		1		ns

4.6 Switching Characteristics

over recommended operating free-air temperature range, $V_{CC} = 5\text{ V} \pm 0.5\text{ V}$ (unless otherwise noted) (see [Load Circuit and Voltage Waveforms](#))

PARAMETER	FROM (INPUT)	TO (OUTPUT)	$T_A = 25^\circ\text{C}$			SN74ACT564		UNIT
			MIN	TYP	MAX	MIN	MAX	
f_{max}			85	90		75		MHz
t_{PLH}	CLK	\bar{Q}	2	6.5	10.5	1.5	11.5	ns
t_{PHL}			1.5	6	9.5	1.5	10.5	
t_{PZH}	\bar{OE}	\bar{Q}	1.5	5.5	9	1.5	9.5	ns
t_{PZL}			1.5	5.5	8.5	1	9.5	
t_{PHZ}	\bar{OE}	\bar{Q}	1.5	7	10.5	1.5	11.5	ns
t_{PLZ}			1.5	5	8	1	8.5	

4.7 Operating Characteristics

$V_{CC} = 5\text{ V}$, $T_A = 25^\circ\text{C}$

PARAMETER	TEST CONDITIONS	TYP	UNIT
C_{pd} Power dissipation capacitance	$C_L = 50\text{ pF}$, $f = 1\text{ MHz}$	50	pF

5 Parameter Measurement Information

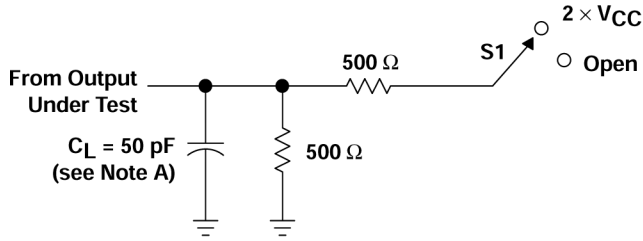

LOAD CIRCUIT

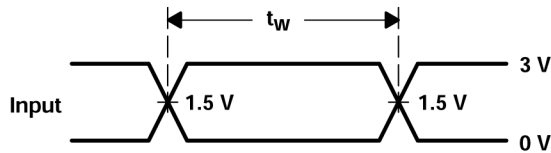

VOLTAGE WAVEFORMS

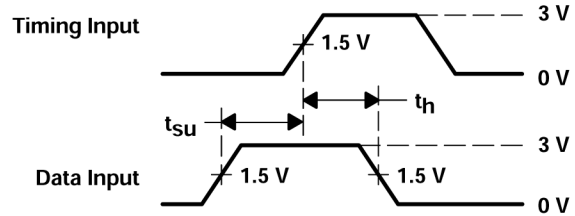

VOLTAGE WAVEFORMS

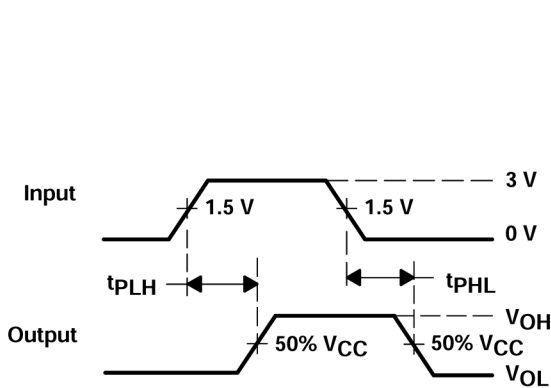

VOLTAGE WAVEFORMS

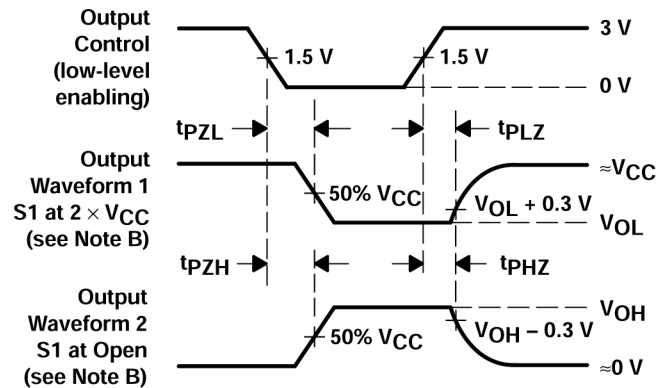

VOLTAGE WAVEFORMS

- C_L includes probe and jig capacitance.
- Waveform 1 is for an output with internal conditions such that the output is low except when disabled by the output control. Waveform 2 is for an output with internal conditions such that the output is high except when disabled by the output control.
- All input pulses are supplied by generators having the following characteristics: $PRR \leq 1 \text{ MHz}$, $Z_O = 50 \Omega$, $t_r \leq 2.5 \text{ ns}$, $t_f \leq 2.5 \text{ ns}$.
- The outputs are measured one at a time with one input transition per measurement.

图 5-1. Load Circuit and Voltage Waveforms

TEST	S1
t_{PLH}/t_{PHL}	Open
t_{PLZ}/t_{PZL}	$2 \times V_{CC}$
t_{PHZ}/t_{PZH}	Open

6 Detailed Description

6.1 Overview

On the positive transition of the clock (CLK) input, the \bar{Q} outputs are set to the complements of the logic levels set up at the data (D) inputs.

A buffered output-enable (\overline{OE}) input places the eight outputs in either a normal logic state (high or low logic levels) or the high-impedance state. In the high-impedance state, the outputs neither load nor drive the bus lines significantly. The high-impedance state and increased drive provide the capability to drive bus lines without interface or pullup components.

\overline{OE} does not affect internal operations of the flip-flops. Old data can be retained or new data can be entered while the outputs are in the high-impedance state.

For specified high-impedance state during power up or power down, \overline{OE} must be tied to V_{CC} through a pullup resistor; the minimum value of the resistor is determined by the current-sinking capability of the driver.

6.2 Functional Block Diagram



图 6-1. Logic Diagram (Positive Logic)

6.3 Device Functional Modes

表 6-1. Function Table (Each Flip-flop)

INPUTS			OUTPUT \bar{Q}
\overline{OE}	CLK	D	
L	↑	H	L
L	↑	L	H
L	H or L	X	\bar{Q}_0
H	X	X	Z

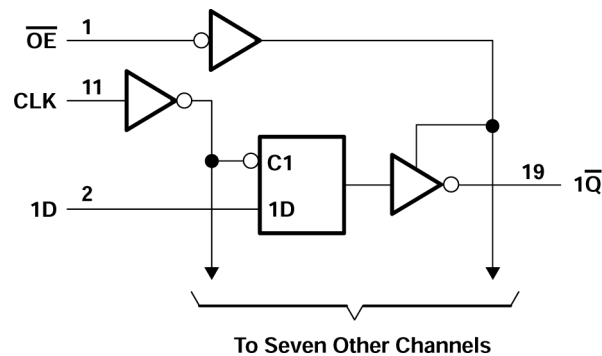
7 Application and Implementation

备注

以下应用部分中的信息不属于 TI 器件规格的范围，TI 不担保其准确性和完整性。TI 的客户应负责确定器件是否适用于其应用。客户应验证并测试其设计，以确保系统功能。

7.1 Power Supply Recommendations

The power supply can be any voltage between the min and max supply voltage rating located in [节 4.2](#).

Each V_{CC} terminal should have a good bypass capacitor to prevent power disturbance. For devices with a single supply, TI recommends $0.1\ \mu\text{F}$ and if there are multiple V_{CC} terminals, then TI recommends $.01\ \mu\text{F}$ or $.022\ \mu\text{F}$ for each power terminal. It is okay to parallel multiple bypass capacitors to reject different frequencies of noise. A $0.1\ \mu\text{F}$ and $1\ \mu\text{F}$ are commonly used in parallel. The bypass capacitor should be installed as close to the power terminal as possible for best results.

7.2 Layout

7.2.1 Layout Guidelines

When using multiple bit logic devices inputs should not ever float.

In many cases, functions or parts of functions of digital logic devices are unused, for example, when only two inputs of a triple-input AND gate are used or only 3 of the 4 buffer gates are used. Such input pins should not be left unconnected because the undefined voltages at the outside connections result in undefined operational states. Specified below are the rules that must be observed under all circumstances. All unused inputs of digital logic devices must be connected to a high or low bias to prevent them from floating. The logic level that should be applied to any particular unused input depends on the function of the device. Generally they will be tied to GND or V_{CC} whichever make more sense or is more convenient. It is generally okay to float outputs unless the part is a transceiver. If the transceiver has an output enable pin it will disable the outputs section of the part when asserted. This does not disable the input section of the IOs so they cannot float when disabled.

7.2.2 Layout Example



图 7-1. Example layout for the SN74ACT564

8 Device and Documentation Support

TI offers an extensive line of development tools. Tools and software to evaluate the performance of the device, generate code, and develop solutions are listed below.

8.1 Documentation Support (Analog)

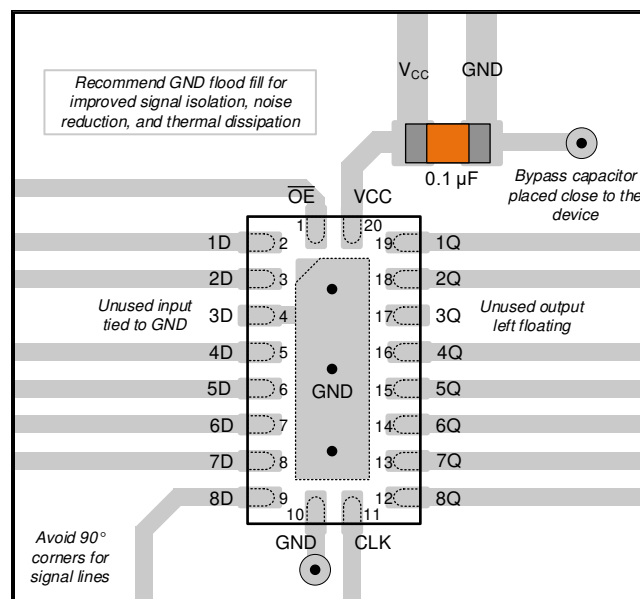
8.1.1 Related Documentation

The table below lists quick access links. Categories include technical documents, support and community resources, tools and software, and quick access to sample or buy.

表 8-1. Related Links

PARTS	PRODUCT FOLDER	SAMPLE & BUY	TECHNICAL DOCUMENTS	TOOLS & SOFTWARE	SUPPORT & COMMUNITY
SN74ACT564	Click here	Click here	Click here	Click here	Click here

8.2 接收文档更新通知

要接收文档更新通知，请导航至 ti.com 上的器件产品文件夹。点击 [通知](#) 进行注册，即可每周接收产品信息更改摘要。有关更改的详细信息，请查看任何已修订文档中包含的修订历史记录。

8.3 支持资源

[TI E2E™ 中文支持论坛](#) 是工程师的重要参考资料，可直接从专家处获得快速、经过验证的解答和设计帮助。搜索现有解答或提出自己的问题，获得所需的快速设计帮助。

链接的内容由各个贡献者“按原样”提供。这些内容并不构成 TI 技术规范，并且不一定反映 TI 的观点；请参阅 TI 的 [使用条款](#)。

8.4 Trademarks

TI E2E™ is a trademark of Texas Instruments.

所有商标均为其各自所有者的财产。

8.5 静电放电警告



静电放电 (ESD) 会损坏这个集成电路。德州仪器 (TI) 建议通过适当的预防措施处理所有集成电路。如果不遵守正确的处理和安装程序，可能会损坏集成电路。

ESD 的损坏小至导致微小的性能降级，大至整个器件故障。精密的集成电路可能更容易受到损坏，这是因为非常细微的参数更改都可能会导致器件与其发布的规格不相符。

8.6 术语表

TI 术语表

本术语表列出并解释了术语、首字母缩略词和定义。

9 Revision History

注：以前版本的页码可能与当前版本的页码不同

Changes from Revision C (August 2023) to Revision D (February 2024)	Page
• 向封装信息表中添加了封装尺寸.....	1
• Updated R ^θ JA values: DW = 58 to 101.2, NS = 60 to 106.2, PW = 83 to 126.2, all values in °C/W	4

Changes from Revision B (November 2002) to Revision C (August 2023)	Page
• 添加了封装信息表、引脚功能表、热信息表、器件功能模式、器件和文档支持部分以及机械、封装和可订购信息部分.....	1
• 删除了对“SN54ACT564”的引用.....	1

10 Mechanical, Packaging, and Orderable Information

The following pages include mechanical, packaging, and orderable information. This information is the most current data available for the designated devices. This data is subject to change without notice and revision of this document. For browser-based versions of this data sheet, refer to the left-hand navigation.

PACKAGING INFORMATION

Orderable Device	Status (1)	Package Type	Package Drawing	Pins	Package Qty	Eco Plan (2)	Lead finish/ Ball material (6)	MSL Peak Temp (3)	Op Temp (°C)	Device Marking (4/5)	Samples
SN74ACT564DW	OBSOLETE	SOIC	DW	20		TBD	Call TI	Call TI	-40 to 85	ACT564	
SN74ACT564DWR	ACTIVE	SOIC	DW	20	2000	RoHS & Green	NIPDAU	Level-1-260C-UNLIM	-40 to 85	ACT564	Samples
SN74ACT564N	ACTIVE	PDIP	N	20	20	RoHS & Non-Green	NIPDAU	N / A for Pkg Type	-40 to 85	SN74ACT564N	Samples
SN74ACT564NSR	ACTIVE	SO	NS	20	2000	RoHS & Green	NIPDAU	Level-1-260C-UNLIM	-40 to 85	ACT564	Samples
SN74ACT564PW	OBSOLETE	TSSOP	PW	20		TBD	Call TI	Call TI	-40 to 85	AD564	
SN74ACT564PWR	ACTIVE	TSSOP	PW	20	2000	RoHS & Green	NIPDAU	Level-1-260C-UNLIM	-40 to 85	AD564	Samples

(1) The marketing status values are defined as follows:

ACTIVE: Product device recommended for new designs.

LIFEBUY: TI has announced that the device will be discontinued, and a lifetime-buy period is in effect.

NRND: Not recommended for new designs. Device is in production to support existing customers, but TI does not recommend using this part in a new design.

PREVIEW: Device has been announced but is not in production. Samples may or may not be available.

OBSOLETE: TI has discontinued the production of the device.

(2) **RoHS:** TI defines "RoHS" to mean semiconductor products that are compliant with the current EU RoHS requirements for all 10 RoHS substances, including the requirement that RoHS substance do not exceed 0.1% by weight in homogeneous materials. Where designed to be soldered at high temperatures, "RoHS" products are suitable for use in specified lead-free processes. TI may reference these types of products as "Pb-Free".

RoHS Exempt: TI defines "RoHS Exempt" to mean products that contain lead but are compliant with EU RoHS pursuant to a specific EU RoHS exemption.

Green: TI defines "Green" to mean the content of Chlorine (Cl) and Bromine (Br) based flame retardants meet JS709B low halogen requirements of <=1000ppm threshold. Antimony trioxide based flame retardants must also meet the <=1000ppm threshold requirement.

(3) MSL, Peak Temp. - The Moisture Sensitivity Level rating according to the JEDEC industry standard classifications, and peak solder temperature.

(4) There may be additional marking, which relates to the logo, the lot trace code information, or the environmental category on the device.

(5) Multiple Device Markings will be inside parentheses. Only one Device Marking contained in parentheses and separated by a "~" will appear on a device. If a line is indented then it is a continuation of the previous line and the two combined represent the entire Device Marking for that device.

(6) Lead finish/Ball material - Orderable Devices may have multiple material finish options. Finish options are separated by a vertical ruled line. Lead finish/Ball material values may wrap to two lines if the finish value exceeds the maximum column width.

Important Information and Disclaimer: The information provided on this page represents TI's knowledge and belief as of the date that it is provided. TI bases its knowledge and belief on information provided by third parties, and makes no representation or warranty as to the accuracy of such information. Efforts are underway to better integrate information from third parties. TI has taken and continues to take reasonable steps to provide representative and accurate information but may not have conducted destructive testing or chemical analysis on incoming materials and chemicals. TI and TI suppliers consider certain information to be proprietary, and thus CAS numbers and other limited information may not be available for release.

In no event shall TI's liability arising out of such information exceed the total purchase price of the TI part(s) at issue in this document sold by TI to Customer on an annual basis.

TAPE AND REEL INFORMATION

QUADRANT ASSIGNMENTS FOR PIN 1 ORIENTATION IN TAPE

*All dimensions are nominal

Device	Package Type	Package Drawing	Pins	SPQ	Reel Diameter (mm)	Reel Width W1 (mm)	A0 (mm)	B0 (mm)	K0 (mm)	P1 (mm)	W (mm)	Pin1 Quadrant
SN74ACT564DWR	SOIC	DW	20	2000	330.0	24.4	10.8	13.3	2.7	12.0	24.0	Q1
SN74ACT564DWR	SOIC	DW	20	2000	330.0	24.4	10.9	13.3	2.7	12.0	24.0	Q1
SN74ACT564NSR	SO	NS	20	2000	330.0	24.4	8.4	13.0	2.5	12.0	24.0	Q1
SN74ACT564NSR	SO	NS	20	2000	330.0	24.4	8.4	13.0	2.5	12.0	24.0	Q1
SN74ACT564PWR	TSSOP	PW	20	2000	330.0	16.4	6.95	7.0	1.4	8.0	16.0	Q1
SN74ACT564PWR	TSSOP	PW	20	2000	330.0	16.4	6.95	7.1	1.6	8.0	16.0	Q1

TAPE AND REEL BOX DIMENSIONS

*All dimensions are nominal

Device	Package Type	Package Drawing	Pins	SPQ	Length (mm)	Width (mm)	Height (mm)
SN74ACT564DWR	SOIC	DW	20	2000	367.0	367.0	45.0
SN74ACT564DWR	SOIC	DW	20	2000	356.0	356.0	45.0
SN74ACT564NSR	SO	NS	20	2000	356.0	356.0	45.0
SN74ACT564NSR	SO	NS	20	2000	367.0	367.0	45.0
SN74ACT564PWR	TSSOP	PW	20	2000	353.0	353.0	32.0
SN74ACT564PWR	TSSOP	PW	20	2000	356.0	356.0	35.0

TUBE

*All dimensions are nominal

Device	Package Name	Package Type	Pins	SPQ	L (mm)	W (mm)	T (μm)	B (mm)
SN74ACT564N	N	PDIP	20	20	506	13.97	11230	4.32

MECHANICAL DATA

NS (R-PDSO-G**)

PLASTIC SMALL-OUTLINE PACKAGE

14-PINS SHOWN



- NOTES:
- A. All linear dimensions are in millimeters.
 - B. This drawing is subject to change without notice.
 - C. Body dimensions do not include mold flash or protrusion, not to exceed 0,15.

N (R-PDIP-T**)

PLASTIC DUAL-IN-LINE PACKAGE

16 PINS SHOWN



- NOTES:
- A. All linear dimensions are in inches (millimeters).
 - B. This drawing is subject to change without notice.
 - Falls within JEDEC MS-001, except 18 and 20 pin minimum body length (Dim A).
 - The 20 pin end lead shoulder width is a vendor option, either half or full width.

DW0020A



PACKAGE OUTLINE

SOIC - 2.65 mm max height

SOIC



4220724/A 05/2016

NOTES:

1. All linear dimensions are in millimeters. Dimensions in parenthesis are for reference only. Dimensioning and tolerancing per ASME Y14.5M.
2. This drawing is subject to change without notice.
3. This dimension does not include mold flash, protrusions, or gate burrs. Mold flash, protrusions, or gate burrs shall not exceed 0.15 mm per side.
4. This dimension does not include interlead flash. Interlead flash shall not exceed 0.43 mm per side.
5. Reference JEDEC registration MS-013.

EXAMPLE BOARD LAYOUT

DW0020A

SOIC - 2.65 mm max height

SOIC



LAND PATTERN EXAMPLE
SCALE:6X



SOLDER MASK DETAILS

4220724/A 05/2016

NOTES: (continued)

- 6. Publication IPC-7351 may have alternate designs.
- 7. Solder mask tolerances between and around signal pads can vary based on board fabrication site.

EXAMPLE STENCIL DESIGN

DW0020A

SOIC - 2.65 mm max height

SOIC



SOLDER PASTE EXAMPLE
BASED ON 0.125 mm THICK STENCIL
SCALE:6X

4220724/A 05/2016

NOTES: (continued)

8. Laser cutting apertures with trapezoidal walls and rounded corners may offer better paste release. IPC-7525 may have alternate design recommendations.
9. Board assembly site may have different recommendations for stencil design.

PW0020A



PACKAGE OUTLINE

TSSOP - 1.2 mm max height

SMALL OUTLINE PACKAGE



4220206/A 02/2017

NOTES:

- All linear dimensions are in millimeters. Any dimensions in parenthesis are for reference only. Dimensioning and tolerancing per ASME Y14.5M.
- This drawing is subject to change without notice.
- This dimension does not include mold flash, protrusions, or gate burrs. Mold flash, protrusions, or gate burrs shall not exceed 0.15 mm per side.
- This dimension does not include interlead flash. Interlead flash shall not exceed 0.25 mm per side.
- Reference JEDEC registration MO-153.

EXAMPLE BOARD LAYOUT

PW0020A

TSSOP - 1.2 mm max height

SMALL OUTLINE PACKAGE



LAND PATTERN EXAMPLE
EXPOSED METAL SHOWN
SCALE: 10X



SOLDER MASK DETAILS

4220206/A 02/2017

NOTES: (continued)

- 6. Publication IPC-7351 may have alternate designs.
- 7. Solder mask tolerances between and around signal pads can vary based on board fabrication site.

EXAMPLE STENCIL DESIGN

PW0020A

TSSOP - 1.2 mm max height

SMALL OUTLINE PACKAGE



SOLDER PASTE EXAMPLE
BASED ON 0.125 mm THICK STENCIL
SCALE: 10X

4220206/A 02/2017

NOTES: (continued)

8. Laser cutting apertures with trapezoidal walls and rounded corners may offer better paste release. IPC-7525 may have alternate design recommendations.
9. Board assembly site may have different recommendations for stencil design.

重要声明和免责声明

TI“按原样”提供技术和可靠性数据（包括数据表）、设计资源（包括参考设计）、应用或其他设计建议、网络工具、安全信息和其他资源，不保证没有瑕疵且不做任何明示或暗示的担保，包括但不限于对适销性、某特定用途方面的适用性或不侵犯任何第三方知识产权的暗示担保。

这些资源可供使用 TI 产品进行设计的熟练开发人员使用。您将自行承担以下全部责任：(1) 针对您的应用选择合适的 TI 产品，(2) 设计、验证并测试您的应用，(3) 确保您的应用满足相应标准以及任何其他功能安全、信息安全、监管或其他要求。

这些资源如有变更，恕不另行通知。TI 授权您仅可将这些资源用于研发本资源所述的 TI 产品的应用。严禁对这些资源进行其他复制或展示。您无权使用任何其他 TI 知识产权或任何第三方知识产权。您应全额赔偿因在这些资源的使用中对 TI 及其代表造成的任何索赔、损害、成本、损失和债务，TI 对此概不负责。

TI 提供的产品受 [TI 的销售条款](#) 或 [ti.com](#) 上其他适用条款/TI 产品随附的其他适用条款的约束。TI 提供这些资源并不会扩展或以其他方式更改 TI 针对 TI 产品发布的适用的担保或担保免责声明。

TI 反对并拒绝您可能提出的任何其他或不同的条款。

邮寄地址：Texas Instruments, Post Office Box 655303, Dallas, Texas 75265
Copyright © 2024，德州仪器 (TI) 公司