

## **AN-1490 LM4702 Power Amplifier**

---

### **ABSTRACT**

This application report presents several useful design techniques and practices that will assist you in creating a successful audio power amplifier design utilizing the LM4702.

---

### **Contents**

1	Introduction .....	2
2	Schematic Diagram .....	3
3	Application Information .....	4
	3.1 Demonstration PCB Board Layout .....	4
	3.2 Bias .....	7
	3.3 Power Supply Design and Transformer Shielding Techniques .....	8
	3.4 Power Supply Bypass Capacitors .....	8
	3.5 Output Options .....	8
	3.6 Sound Quality .....	8
4	THD+N vs Output Power .....	9
5	Bill of Materials (BOM) .....	10
6	Conclusion .....	11

### **List of Figures**

1	Complete LM4702-Based 100W/Channel High-Fidelity Power Amplifier .....	2
2	Fully Complementary LM4702-Based High Fidelity Stereo Power Amplifier.....	3
3	Recommended PCB Layout, Top Layer .....	5
4	Recommended PCB Layout, Top Silkscreen .....	6
5	Recommended PCB Layout, Bottom Layer .....	7
6	THD+N vs Output Power $R_L = 8\Omega$ , $V_{supply} = \pm 50VDC$ .....	9

### **List of Tables**

1	Bill of Materials.....	10
---	------------------------	----

## 1 Introduction

Following these steps results in an amplifier that measures well in the universally accepted key parameters such as THD+N (0.0006% THD), SNR, frequency response, noise and other audio specifications. In addition, these techniques will also assist the designer in creating an audio amplifier that has performance comparable to other amplifiers, which are considered high fidelity.



**Figure 1. Complete LM4702-Based 100W/Channel High-Fidelity Power Amplifier**

## 2 Schematic Diagram

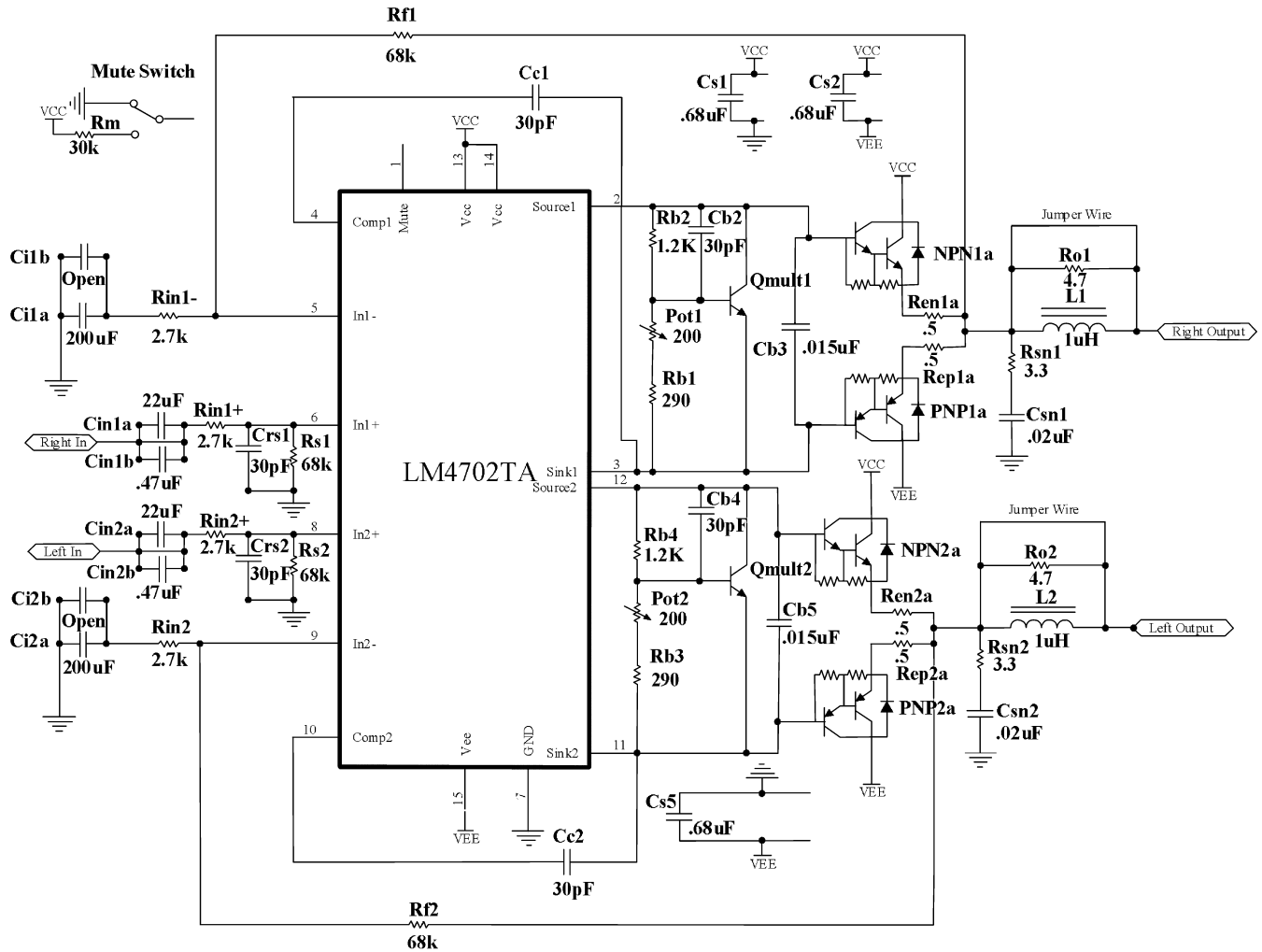

Figure 2. Fully Complementary LM4702-Based High Fidelity Stereo Power Amplifier

### 3 Application Information

#### 3.1 Demonstration PCB Board Layout

As with all low noise, high quality circuit board layouts, the LM4702 power amplifier driver requires careful consideration. A good place to start is with the ground and power circuits design layout.

Star connections for ground and power are always a good practice for audio circuit board layouts. A star connection is where there are individual traces from each component in the circuit that return to a central point. A good example of this can be seen in the artwork for the LM4702 demonstration board shown in [Figure 2](#). Notice how all the ground traces converge at the left side of the board, near Rs1 and Rs2, and connect to the two ground pins in the center of the power connector. The ground traces that connect to the right and left output jacks also converge at the center of the star ground which is the center of the power connector where the two ground pins are located.

The same star configuration for routing ground traces can also be applied to power supply traces. This is not as obvious on the LM4702 demonstration board because the power supply connections for the left and right output stages are completed through separate cables at the top edge of the demonstration board. The power connections for the LM4702 chip come through the connector at the bottom of the board where the center of the star ground also connects. This effectively creates a star power circuit because there are separate wires connected to the main power supply capacitors from each output stage and the LM4702. The primary reason for this star is that the power traces to the Complementary Darlington output devices and the LM4702 must be kept separate. If they are not kept separate, then the high current being drawn by the output stage can affect, or even modulate, the power supply levels for the LM4702 chip. This will increase distortion and will negatively impact the quality of the audio output signal.

Ground planes and power planes must be avoided. A ground plane is a large area of copper commonly used in digital circuit boards. All the ICs connect their ground pins to this large area of copper and do not use individual traces to connect to a central ground. In a high fidelity amplifier, this will create confusing ground paths (ground loops) that produce adverse effects on the output signal. A very audible hum is one of the most noticeable effects of ground loops caused by ground planes.

Designing a PCB with separate ground traces and power supply traces requires extra layout design time, but the final cost of the board will not change. The cost may actually decrease if the board is kept to a two layers design instead of multi-layer designs, common in digital circuit boards.

Maintaining symmetry in the right and left channel areas of the PCB artwork is important. PCB artwork symmetry means that the left and right sections of the circuit look very similar if not exactly the same with the same trace lengths and widths. In some cases a mirror image of the left to the right sides of the artwork on the circuit board create the proper balanced (identical left and right channel) measurements in the final design. Example: In order to achieve 0.0006% THD+N for the right and left channel circuits, the ground connections on the board had to be identical in length and width to under 0.01" (.25mm) of an inch and had to have identical geometries on both sides of the board. THD+N numbers of 0.01% or better can be achieved without such careful considerations but again the final cost of the circuit board will be the same for a mediocre layout or one which is carefully designed.

A more specific point about the LM4702 demonstration board artwork to notice is on the top layer of the amplifier circuit board where a trace is connected to Sink 1 on pin 3 of the LM4702 that heads off to the output Darlington Transistors and a second trace is connected to Sink 2 on pin 11. Through several iterations of the artwork it was discovered that these two traces require a minimum spacing of 0.1" (2.54mm) to avoid possible oscillations. The reason for this is because this is the most sensitive point for both channels and therefore there should not be any coupling between these two points. Thus the reason for a minimum spacing of 0.1" (2.54mm) between these two traces.

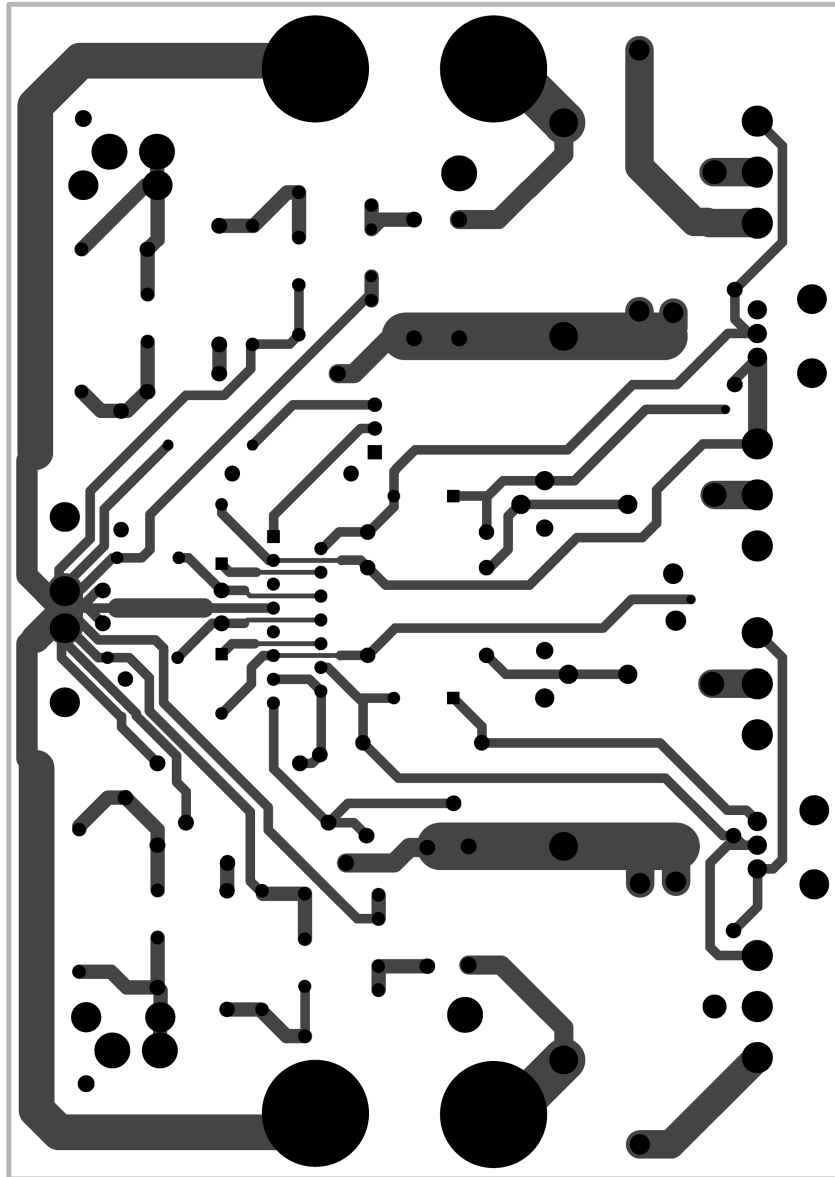

Figure 3. Recommended PCB Layout, Top Layer

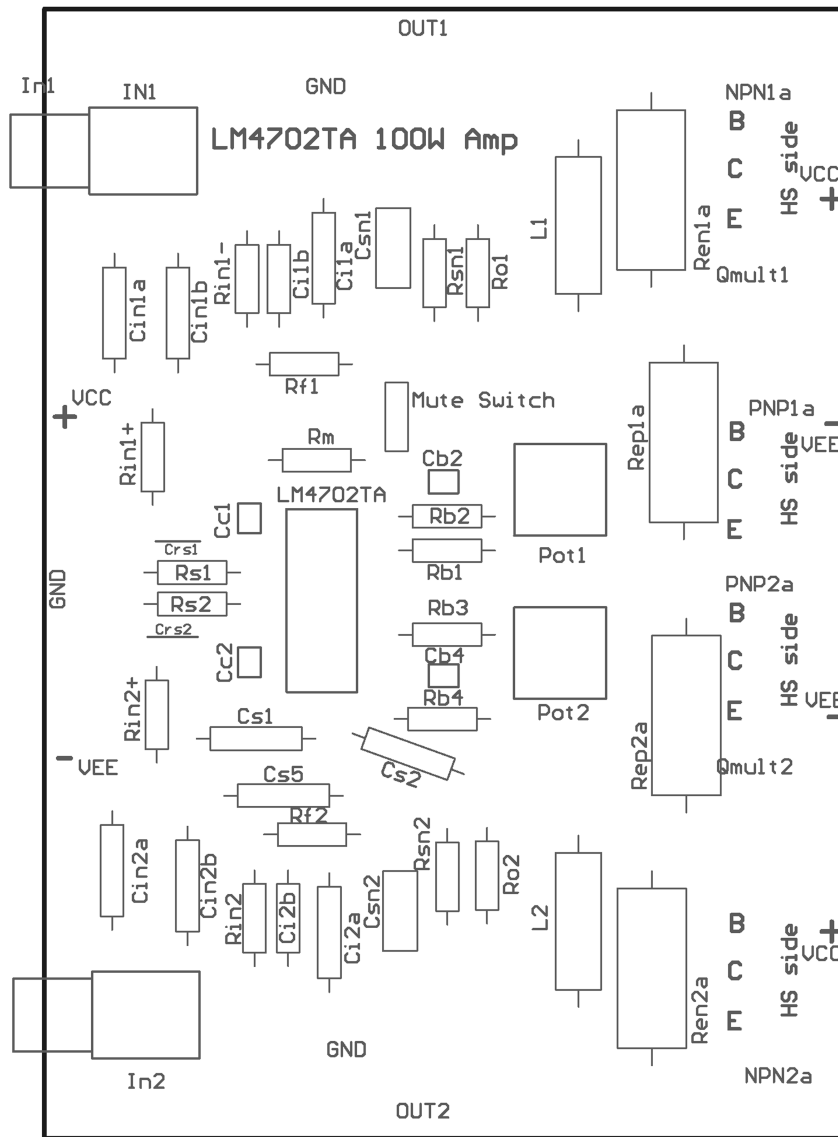
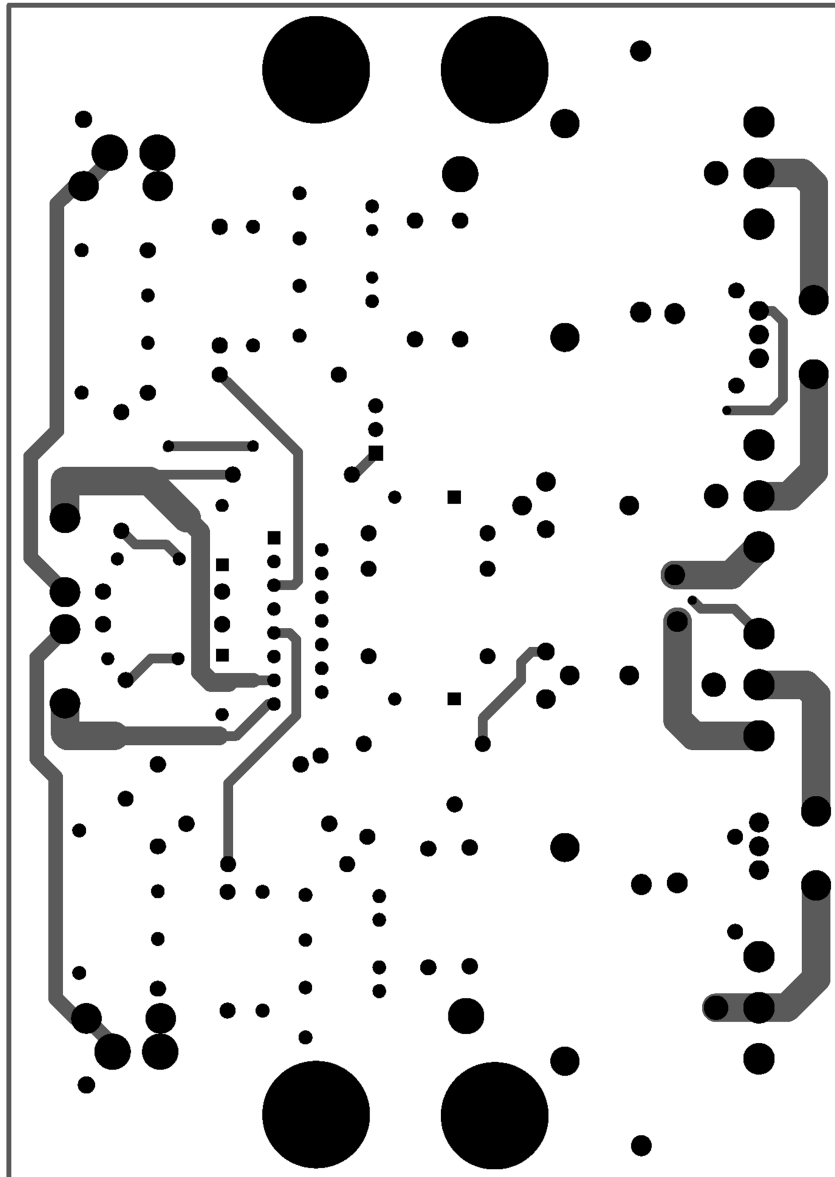

Figure 4. Recommended PCB Layout, Top Silkscreen



**Figure 5. Recommended PCB Layout, Bottom Layer**

### 3.2 Bias

A new Texas Instruments wafer fabrication process is used to create the LM4702 high voltage driver. This allows reduced bias levels while maintaining THD+N 0.0006% performance

AN external  $V_{BE}$  multiplier circuit in the LM4702 Demo Amplifier sets the output stage bias. It also provides inverse thermal tracking to maintain the bias level as the output stage temperature changes, see [Figure 2](#). Transistors  $Q_{mult1}$  and  $Q_{mult2}$  (presently a D44C8 or a TIP31A ) are physically mounted on the heatsink between the NPN and PNP Darlington output devices, providing the best inverse thermal tracking possible. The ability to set lower bias levels on the LM4702 means less wasted power and less heat.

The LM4702 Demonstration Stereo Power Amplifier achieves THD+N as low as 0.0006% with only 15 to 20mA of bias current. Increasing the bias to drive the class AB Darlington output stage into a more Class A region of operation was tested, but there was no improvement in THD+N or any other audio measurements. There was also no improvement in the critical listening tests performed at Texas Instruments in-house dedicated sound room.

The LM4702 demonstration amplifier uses  $0.5\Omega$  degeneration resistors in the emitter circuits of the Darlingtons used in the output stage. A  $0.5\Omega$  assures maximum protection and stability. However,  $0.33\Omega$  or less could be used to slightly increase output power.

### 3.3 Power Supply Design and Transformer Shielding Techniques

The power supply used in the LM4702 Demonstration Stereo Power Amplifier is a simple unregulated, full-wave bridge-rectified configuration. The transformers were chosen based on size constraints in the enclosure and their ability to provide 100W per channel into an  $8\Omega$  speaker load. Two toroidal transformers rather than one large transformer had to be mounted, one on each side of the enclosure, to get the required VA (Volts X Amp) rating and still fit in the small box. For part #'s and suppliers, see [Table 1](#). This configuration of one transformer on each side of the enclosure allowed the use of a separate transformer and diode bridge for each of the 50 VDC (positive and negative) supply rails in the amplifier.

Because the enclosure design was small, the close proximity of the two toroidal transformers to the circuit board necessitated shielding both transformers with "Mu-Metal" for best performance. The Mu-Metal mitigates the field interference generated by the transformers to the sensitive circuits on the amplifier printed circuit board. Toroidal transformers already have low radiated fields when compared with iron core transformers, but are more costly. Toroidal transformers are used extensively in high end audio equipment for their low radiated magnetic field characteristic. However, even with the lower level magnetic fields that they radiate, problems can still occur when trying to achieve the lowest possible distortion and noise. Mu-Metal type shielding is only effective when it makes a complete loop around the entire perimeter of the toroidal transformer but it does not need to be grounded to be effective.

### 3.4 Power Supply Bypass Capacitors

There are two small  $0.47\mu\text{F}$  film type bypass capacitors on the demo board from each 50VDC power supply to ground. In addition there is a third  $0.47\mu\text{F}$  capacitor across the plus and minus 50VDC rails (from the positive to the negative rail). This capacitor is placed across the tops of the other two bypass capacitors. There is also a pair of the same capacitors across the two large  $27,000\mu\text{F}$  power supply capacitors. Large electrolytic capacitors can become inductive at higher frequencies and these much smaller film type bypass capacitors will shunt out these undesirable effects. The main power supply filter capacitors were chosen to be the low ESR type which have proved to best for high-end audio applications in past designs. As is most often the case in audio power amplifier design, their value was chosen based on what was the largest value, lowest ESR capacitor available with a 75 to 80 VDC rating... that would fit in the box!

### 3.5 Output Options

The LM4702 device is limited to 5mA of output drive current capability. The demo amplifier uses a Complementary Darlington output stage to get the current gain required to drive an  $8\Omega$  load to 100W.

Low voltage turn on FET Complementary Output stages can also be used. They must be Low  $V_t$  however because the differential output of the LM4702 is limited to 6VDC.

### 3.6 Sound Quality

Sound quality can be a very heated and subjective debate. However, some feel that there are differences that can be heard between different pieces of equipment and that almost all of these can be quantified. Of course for any single or double blind test to be valid, output levels of the units under test should be matched as closely as possible. 0.1dB difference in output levels at a single location for a single listener is recommended, but 1dB level matching has proved to be sufficient.



### 3.6.1 Parts Selection

In listening tests at TI's sound room evaluating different circuit components used in the LM4702 demo amplifier, there was one part whose negative effect on audible signal quality was undeniable. A DC blocking capacitor on the input of the LM4702 degraded sound quality. In multiple listening tests, with different participants and at various locations around the country, the negative effects of even the best film and foil polystyrene DC blocking input capacitors in the audio signal path was confirmed. It is therefore recommended that DC blocking capacitors not be used in the signal path for mid to high-end audio equipment. Where DC offset from another signal source may be a problem then the use of a DC servo circuit that keeps DC offset from appearing at the output of the amplifier is recommended.

A significant amount has been written in the Audiophile Press about how different types of passive components affect perceived sound quality. All of the passive components used in the demo amplifier are standard, commercially available parts. For example RN60 and RN55 metal film resistors were used for all the resistors on the demo board.

### 3.6.2 Wiring Techniques

Wiring techniques can have an effect on sound quality. Point to point wiring, star ground and star power routing of supply wires will improve noise measurements and have an effect on perceived "sound quality". Large gauge wire will reduce IR losses (Current X Resistance losses) and thus improve amplifier efficiency slightly. Also good connections are a basic requirement in properly constructed power amplifier.

## 4 THD+N vs Output Power

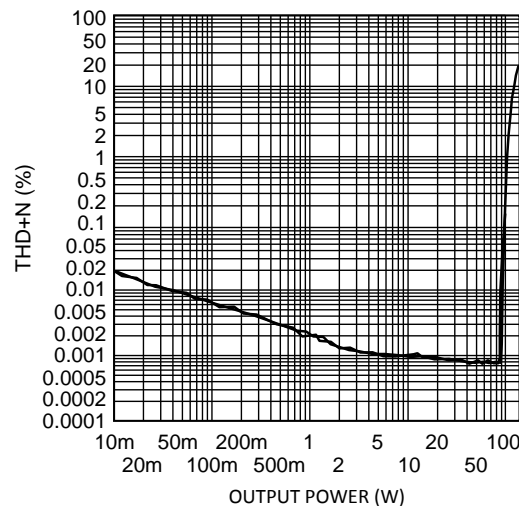

**Figure 6. THD+N vs Output Power**  
 $R_L = 8\Omega$ ,  $V_{supply} = \pm 50VDC$

## 5 Bill of Materials (BOM)

### Analog Audio LM4702TA Compact 100W AMP Demo Board

Assembly Part Number: 980012762-100

A3

**Table 1. Bill of Materials**

Item	Qty	Part Number	Part Description	Ref Designator	Remark
1	1	551012762-001	LM4702 PCB		
2	4	Res 0.5 $\Omega$ 5W	Resistor	Rep 1a-2a, Ren 1a-2a	Newark 02F1344
3	4	Res 68K $\Omega$ 1% 0.25W Axial	Resistor	Rs1-2, Rf1-2	Digikey P68.0KCACT-ND
4	4	Res 2.7K $\Omega$ 1% 0.25W Axial	Resistor	Rin1+, Rin-, Rin2+, Rin2-	Digikey P2.70KCACT-ND
5	2	Res 249 $\Omega$ 1% 0.25W Axial	Resistor	Rb1, Rb3	Digikey 249XBK-ND
6	2	Res 1.21K $\Omega$ 1% 0.25W Axial	Resistor	Rb2, Rb4	Digikey 1.21KXBK-ND
7	1	Res 30.1K $\Omega$ 1% 0.25W Axial	Resistor	Rm	Digikey 30.1KXBK-ND
8	2	Res 3.3 $\Omega$ 1% 0.25W Axial	Resistor	Rsn1, Rsn2	Digikey PPC3.3BCT-ND
9	2	Res 4.7 $\Omega$ 1% 0.25W Axial	Resistor	R01, R02	Digikey PPC4.7BCT-ND
10	2	Pot 200 $\Omega$ 1 Turn Top Adjust	Resistor	Pot1, Pot2	Digikey 3345P-201-ND Newark 01F7215
11	3	Cap Polyester Mylar 0.68 $\mu$ F 250VDC Radial	Capacitor	Cs1, Cs2, Cs5	Panasonic ECQ-E2684KF
12	2	Cap Polyester Mylar 1.0 $\mu$ F 100VDC Radial	Capacitor	See Drawing	Panasonic ECQ-E4105KF
13	4	Cap Mica 30pF 500V Radial	Capacitor	Cc 1, Cc2, Cb2, Cb4	Digikey 338-1076-ND
14	2	Cap Mica 30pF 500V Radial	Capacitor	Crs1, Crs2	Digikey 338-1076-ND
15	2	Electrolytic Cap 220 $\mu$ F 35V Radial	Capacitor	Ci1a, Ci2a	Panasonic EEU-FC1V221
16	0	Polypropylene Cap 0.1 $\mu$ F 630V Radial	Capacitor		Panasonic ECQ-P6104JU
17	2	Polypropylene Cap 0.015 $\mu$ F 1250V Radial	Capacitor	See Drawing	Panasonic ECQ-P1H153FZW
18	2	Polyester Cap 0.022 $\mu$ F 630VDC Radial	Capacitor	Csn1, Csn2	Panasonic ECQ-E6223KZ
19	2	Transistor TIP31A	Transistor	See Drawing	Fairchild D44C8
20	2	Transistor MN2488	Darlington	See Drawing	Newark 37C2041
21	2	Transistor MP1620	Darlington	See Drawing	Newark 37C2111
22	2	Connector Vert PCB 3 Pos	Connector	See Drawing	Molex 26-61-4030
23	4	Binding Post	Connector	See Drawing	Digikey 111-2223-001
24	4	Connector Vert PCB 5 Pos	Output Connector	See Drawing	Molex 26-61-4060
25	1	Connector Vert PCB 6 Pos	Power Connector to LM4702 chip	See Drawing	Molex 26-61-4060
26	2	Wire 16 AWG	Jumper	L1, L2	

## 6 Conclusion

Every amplifier design creates its own set of unique constraints that will be have to be dealt with by the designer but the simplicity of the LM4702 keeps these constraints to a minimum and it does this at a level of distortion (0.006%THD in a complete amplifier) and audible audio quality that is unmatched!

## IMPORTANT NOTICE

Texas Instruments Incorporated and its subsidiaries (TI) reserve the right to make corrections, enhancements, improvements and other changes to its semiconductor products and services per JESD46, latest issue, and to discontinue any product or service per JESD48, latest issue. Buyers should obtain the latest relevant information before placing orders and should verify that such information is current and complete. All semiconductor products (also referred to herein as "components") are sold subject to TI's terms and conditions of sale supplied at the time of order acknowledgment.

TI warrants performance of its components to the specifications applicable at the time of sale, in accordance with the warranty in TI's terms and conditions of sale of semiconductor products. Testing and other quality control techniques are used to the extent TI deems necessary to support this warranty. Except where mandated by applicable law, testing of all parameters of each component is not necessarily performed.

TI assumes no liability for applications assistance or the design of Buyers' products. Buyers are responsible for their products and applications using TI components. To minimize the risks associated with Buyers' products and applications, Buyers should provide adequate design and operating safeguards.

TI does not warrant or represent that any license, either express or implied, is granted under any patent right, copyright, mask work right, or other intellectual property right relating to any combination, machine, or process in which TI components or services are used. Information published by TI regarding third-party products or services does not constitute a license to use such products or services or a warranty or endorsement thereof. Use of such information may require a license from a third party under the patents or other intellectual property of the third party, or a license from TI under the patents or other intellectual property of TI.

Reproduction of significant portions of TI information in TI data books or data sheets is permissible only if reproduction is without alteration and is accompanied by all associated warranties, conditions, limitations, and notices. TI is not responsible or liable for such altered documentation. Information of third parties may be subject to additional restrictions.

Resale of TI components or services with statements different from or beyond the parameters stated by TI for that component or service voids all express and any implied warranties for the associated TI component or service and is an unfair and deceptive business practice. TI is not responsible or liable for any such statements.

Buyer acknowledges and agrees that it is solely responsible for compliance with all legal, regulatory and safety-related requirements concerning its products, and any use of TI components in its applications, notwithstanding any applications-related information or support that may be provided by TI. Buyer represents and agrees that it has all the necessary expertise to create and implement safeguards which anticipate dangerous consequences of failures, monitor failures and their consequences, lessen the likelihood of failures that might cause harm and take appropriate remedial actions. Buyer will fully indemnify TI and its representatives against any damages arising out of the use of any TI components in safety-critical applications.

In some cases, TI components may be promoted specifically to facilitate safety-related applications. With such components, TI's goal is to help enable customers to design and create their own end-product solutions that meet applicable functional safety standards and requirements. Nonetheless, such components are subject to these terms.

No TI components are authorized for use in FDA Class III (or similar life-critical medical equipment) unless authorized officers of the parties have executed a special agreement specifically governing such use.

Only those TI components which TI has specifically designated as military grade or "enhanced plastic" are designed and intended for use in military/aerospace applications or environments. Buyer acknowledges and agrees that any military or aerospace use of TI components which have **not** been so designated is solely at the Buyer's risk, and that Buyer is solely responsible for compliance with all legal and regulatory requirements in connection with such use.

TI has specifically designated certain components as meeting ISO/TS16949 requirements, mainly for automotive use. In any case of use of non-designated products, TI will not be responsible for any failure to meet ISO/TS16949.

### Products

Audio	<a href="http://www.ti.com/audio">www.ti.com/audio</a>
Amplifiers	<a href="http://amplifier.ti.com">amplifier.ti.com</a>
Data Converters	<a href="http://dataconverter.ti.com">dataconverter.ti.com</a>
DLP® Products	<a href="http://www.dlp.com">www.dlp.com</a>
DSP	<a href="http://dsp.ti.com">dsp.ti.com</a>
Clocks and Timers	<a href="http://www.ti.com/clocks">www.ti.com/clocks</a>
Interface	<a href="http://interface.ti.com">interface.ti.com</a>
Logic	<a href="http://logic.ti.com">logic.ti.com</a>
Power Mgmt	<a href="http://power.ti.com">power.ti.com</a>
Microcontrollers	<a href="http://microcontroller.ti.com">microcontroller.ti.com</a>
RFID	<a href="http://www.ti-rfid.com">www.ti-rfid.com</a>
OMAP Applications Processors	<a href="http://www.ti.com/omap">www.ti.com/omap</a>
Wireless Connectivity	<a href="http://www.ti.com/wirelessconnectivity">www.ti.com/wirelessconnectivity</a>

### Applications

Automotive and Transportation	<a href="http://www.ti.com/automotive">www.ti.com/automotive</a>
Communications and Telecom	<a href="http://www.ti.com/communications">www.ti.com/communications</a>
Computers and Peripherals	<a href="http://www.ti.com/computers">www.ti.com/computers</a>
Consumer Electronics	<a href="http://www.ti.com/consumer-apps">www.ti.com/consumer-apps</a>
Energy and Lighting	<a href="http://www.ti.com/energy">www.ti.com/energy</a>
Industrial	<a href="http://www.ti.com/industrial">www.ti.com/industrial</a>
Medical	<a href="http://www.ti.com/medical">www.ti.com/medical</a>
Security	<a href="http://www.ti.com/security">www.ti.com/security</a>
Space, Avionics and Defense	<a href="http://www.ti.com/space-avionics-defense">www.ti.com/space-avionics-defense</a>
Video and Imaging	<a href="http://www.ti.com/video">www.ti.com/video</a>

### TI E2E Community

[e2e.ti.com](http://e2e.ti.com)