

# OPA561 High-Current, High-Speed Operational Amplifier

## 1 Features

- 1.2-A output current
- 12- $V_{PP}$  output voltage
- Wide power range
  - Single supply: 7 V to 15 V
  - Dual supply:  $\pm 3.5$  V to  $\pm 7.5$  V
- Fully protected
  - Thermal shutdown
  - Adjustable current limit
- Output disable control
- 17-MHz gain-bandwidth product
- 50-V/ $\mu$ s slew rate
- 1-MHz full-power bandwidth
- Thermally enhanced HTSSOP-20 PowerPAD™ integrated circuit package
- Temperature range: 0°C to 125°C

## 2 Applications

- Power-line communications
- Valve-actuator drivers
- Power supplies
- Test equipment
- Tec drivers
- Laser diode drivers

## 3 Description

The OPA561 is a low-cost, high-current operational amplifier capable of driving up to 1.2-A pulses into reactive loads. This monolithic integrated circuit provides high reliability in demanding line-carrier communications, laser diode drivers, and motor-control applications. The high slew rate provides 1 MHz of full-power bandwidth and excellent linearity.

For design flexibility, the OPA561 operates from either a single supply in the range of 7 V to 15 V or dual power supplies of  $\pm 3.5$  V to  $\pm 7.5$  V. In single-supply operation, the input common-mode range extends below ground. At maximum output current, a wide output swing provides a 12  $V_{PP}$  capability with a nominal 15-V supply.

The OPA561 is internally protected against overtemperature conditions and current overloads. In addition, the OPA561 is designed to provide an accurate, user-selected, current limit. The current limit can be adjusted from 0.2 A to 1.2 A with a low-power resistor or potentiometer, or DAC (digital-to-analog converter). The high-speed characteristics of the current control loop provide accuracy, even under pulsed-load conditions.

The enable and status (E/S) pin performs two functions: the pin can be monitored to determine if the device is in thermal shutdown (active low), and can also be forced low to disable the output, thus disconnecting the load.

The OPA561 is available in a miniature HTSSOP-20 PowerPAD integrated circuit package. This surface-mount package is thermally enhanced and has a very low thermal resistance. Operation is specified over the industrial temperature range of 0°C to 125°C.

### Package Information

PART NUMBER	PACKAGE <sup>(1)</sup>	PACKAGE SIZE <sup>(2)</sup>
OPA561	PWP (HTSSOP, 20)	6.5 mm × 6.4 mm

(1) For more information, see [Section 10](#).

(2) The package size (length × width) is a nominal value and includes pins, where applicable.

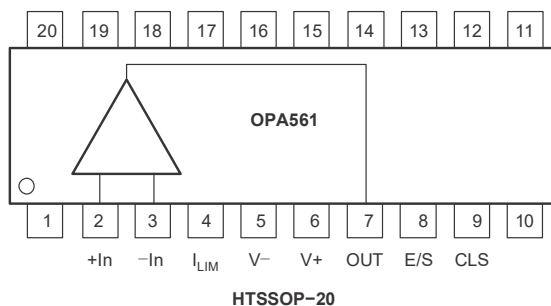

NOTE: Pins 1, 10, and 11–20 are not connected.  
 Flag must be connected to V-.

### Pinout Diagram



## Table of Contents

<b>1 Features</b> .....	1	7.1 Application Information.....	13
<b>2 Applications</b> .....	1	7.2 Typical Application.....	18
<b>3 Description</b> .....	1	7.3 Power Supply Recommendations.....	20
<b>4 Pin Configuration and Functions</b> .....	3	7.4 Layout.....	20
<b>5 Specifications</b> .....	4	<b>8 Device and Documentation Support</b> .....	21
5.1 Absolute Maximum Ratings.....	4	8.1 Device Support.....	21
5.2 ESD Ratings.....	4	8.2 Receiving Notification of Documentation Updates....	21
5.3 Recommended Operating Conditions.....	4	8.3 Support Resources.....	21
5.4 Thermal Information.....	4	8.4 Trademarks.....	21
5.5 Electrical Characteristics.....	5	8.5 Electrostatic Discharge Caution.....	21
5.6 Typical Characteristics.....	7	8.6 Glossary.....	21
<b>6 Detailed Description</b> .....	10	<b>9 Revision History</b> .....	22
6.1 Overview.....	10	<b>10 Mechanical, Packaging, and Orderable Information</b> .....	22
6.2 Feature Description.....	10		
<b>7 Application and Implementation</b> .....	13		

## 4 Pin Configuration and Functions

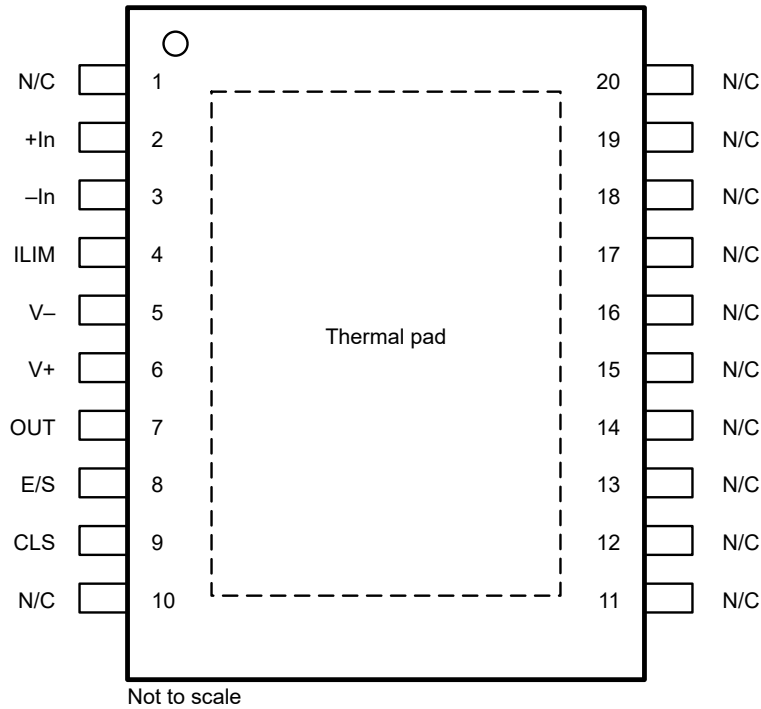

**Figure 4-1. PWP Package, 20-Pin HTSSOP (Top View)**

**Table 4-1. Pin Functions**

PIN		TYPE <sup>(1)</sup>	DESCRIPTION
NAME	NO.		
1	N/C	—	No electrical connection. Solder this pin to the printed circuit board (PCB).
2	+In	I	Noninverting input
3	–In	I	Inverting input
4	I <sub>LIM</sub>	I	Adjustable current limit pin
5	V–	G	Negative supply
6	V+	P	Positive supply
7	OUT	O	Output
8	E/S	I/O	Enable and status pin
9	CLS	O	Overcurrent status flag
10-20	N/C	—	No electrical connection. Solder this pin to the printed circuit board (PCB).
Pad	Thermal pad	—	Connect the thermal pad to the most negative supply of the device, V–.

(1) I = input, O = output, G = ground, P = power.

## 5 Specifications

### 5.1 Absolute Maximum Ratings

over operating free-air temperature range (unless otherwise noted)<sup>(1)</sup>

		MIN	MAX	UNIT
	Supply voltage, V- to V+		16	V
	Input voltage	(V-) - 0.4	(V+) + 0.5	V
	Input shutdown voltage	(V-) - 0.4	(V-) + 0.5	V
	Junction temperature		150	°C
T <sub>stg</sub>	Storage temperature	-65	150	°C

- (1) Operation outside the *Absolute Maximum Ratings* may cause permanent device damage. *Absolute Maximum Ratings* do not imply functional operation of the device at these or any other conditions beyond those listed under *Recommended Operating Conditions*. If used outside the *Recommended Operating Conditions* but within the *Absolute Maximum Ratings*, the device may not be fully functional, and this may affect device reliability, functionality, performance, and shorten the device lifetime.

### 5.2 ESD Ratings

			VALUE	UNIT
V <sub>(ESD)</sub>	Electrostatic discharge	Human-body model (HBM), per ANSI/ESDA/JEDEC JS-001 <sup>(1)</sup>	±2000	V
		Charged device model (CDM), per ANSI/ESDA/JEDEC JS-002 <sup>(2)</sup>	±1000	

- (1) JEDEC document JEP155 states that 500-V HBM allows safe manufacturing with a standard ESD control process.  
 (2) JEDEC document JEP157 states that 250-V CDM allows safe manufacturing with a standard ESD control process.

### 5.3 Recommended Operating Conditions

over operating free-air temperature range (unless otherwise noted)

		MIN	NOM	MAX	UNIT
V <sub>S</sub>	Specified voltage	7	15	16	V
T <sub>J</sub>	Specified junction temperature	0		125	°C

### 5.4 Thermal Information

THERMAL METRIC <sup>(1)</sup>			OPA561	UNIT
			PWP (HTSSOP)	
			20 PINS	
R <sub>θJA</sub>	Junction-to-ambient thermal resistance	2-oz trace and 9-in <sup>2</sup> copper pad with solder	32	°C/W
		Without heat sink	100	
R <sub>θJC(bot)</sub>	Junction-to-case (bottom) thermal resistance		1.4	°C/W

- (1) For more information about traditional and new thermal metrics, see the [Semiconductor and IC package thermal metrics](#) application report.

## 5.5 Electrical Characteristics

at  $T_{CASE} = 25^{\circ}C$ ,  $V_S = 15 V$ , load connected to  $V/2$ , and E/S enabled (unless otherwise noted)

PARAMETER		TEST CONDITIONS	MIN	TYP	MAX	UNIT
<b>OFFSET VOLTAGE, <math>V_S = 12 V</math></b>						
$V_{OS}$	Input offset voltage	$V_{CM} = 0 V$		-3	±20	mV
$dV_{OS}/dT$	Input offset voltage vs temperature	$T_A = 0^{\circ}C$ to $125^{\circ}C$		±50		$\mu V/^{\circ}C$
PSRR	Input Offset Voltage vs Power Supply	$V_{CM} = 0 V$ , $V_S = 7 V$ to $16 V$		25	150	$\mu V/V$
<b>INPUT BIAS CURRENT<sup>(1)</sup></b>						
$I_B$	Input bias current	$V_{CM} = 0 V$		10	100	pA
$I_{OS}$	Input offset current	$V_{CM} = 0 V$		10	100	pA
<b>NOISE</b>						
$e_n$	Input voltage noise density	$f = 1 kHz$		83		$nV/\sqrt{Hz}$
		$f = 10 kHz$		32		
		$f = 100 kHz$		14		
$i_n$	Current noise	$f = 1 kHz$		4		$fA/\sqrt{Hz}$
<b>INPUT VOLTAGE RANGE</b>						
$V_{CM}$	Common-mode voltage	Linear operation	$(V-) - 0.1$		$(V+) - 3$	V
CMRR	Common-mode rejection ratio	$V_S = 15 V$ , $V_{CM} = (V-) - 0.1 V$ to $(V+) - 3 V$	70	80		dB
<b>INPUT IMPEDANCE</b>						
	Differential			$1.8 \times 10^{11}$    10		$\Omega$    pF
	Common-mode			$1.8 \times 10^{11}$    18.5		$\Omega$    pF
<b>OPEN-LOOP GAIN</b>						
$A_{OL}$	Open-loop voltage Gain	$V_O = 10 V_{PP}$ , $R_L = 5 \Omega$	80	100		dB
<b>FREQUENCY RESPONSE</b>						
GBW	Gain-bandwidth product	$R_L = 5 \Omega$		17		MHz
SR	Slew Rate	$G = 1$ , 10-V step, $R_L = 5 \Omega$		50		V/ $\mu s$
	Full-power bandwidth	$G = +2$ , $V_{OUT} = 10 V_{p-p}$		1		MHz
	Settling time: ±0.1%	$G = -1$ , 10-V step		1		$\mu s$
THD+N	Total harmonic distortion + noise	$f = 1 kHz$ , $R_L = 5 \Omega$ , $G = +2$ , $V_O = 10 V_{PP}$		0.02		%
		$f = 1 MHz$		3		
<b>OUTPUT</b>						
	Voltage output	Positive, $I_O = 0.5 A$	$(V+) - 1$	$(V+) - 0.7$		V
		Negative, $I_O = -0.5 A$	$(V-) + 1$	$(V-) + 0.7$		
		Positive, $I_O = 1 A$	$(V+) - 1.5$	$(V+) - 1.2$		
		Negative, $I_O = -1 A$	$(V-) + 1.5$	$(V-) + 1.2$		
	Maximum continuous current output, dc			1.2		A
$Z_O$	Output impedance	$G = +2$ , $f = 100 kHz$		0.05		$\Omega$
	Output current limit Range			±0.2 to ±1.2		A
	Current limit tolerance <sup>(2)</sup>	$R_{CL} = 2 k\Omega$ ( $I_{LIM} = \pm 1 A$ )		±50		mA
	Asymmetry	Comparing positive and negative limits		10		%
	Current limit overshoot <sup>(3)</sup>	$V = 5-V$ pulse (200 ns $t_r$ ), $G = +2$		50		%

## 5.5 Electrical Characteristics (continued)

at  $T_{CASE} = 25^{\circ}\text{C}$ ,  $V_S = 15\text{ V}$ , load connected to  $V/2$ , and E/S enabled (unless otherwise noted)

PARAMETER		TEST CONDITIONS	MIN	TYP	MAX	UNIT
	Output disabled	Output resistance		10		$\text{M}\Omega$
		Output capacitance		140		$\text{pF}$
<b>OUTPUT ENABLE/STATUS AND FLAG PINS</b>						
	Shutdown input mode, $V_{E/S}$ high (output enabled) <sup>(4)</sup>	E/S pin open or forced high	$(V-) + 2$		$(V-) + 5$	V
	Shutdown input mode, $V_{E/S}$ low (output disabled)	E/S pin forced low	$(V-) - 0.4$		$(V-) + 0.8$	V
	Shutdown input mode, $I_{E/S}$ high (output enabled)	E/S pin indicates high		20		$\mu\text{A}$
	Shutdown input mode, $I_{E/S}$ low (output disabled)	E/S pin indicates low		0.1		$\mu\text{A}$
	Output disable time			50		ns
	Output enable time			3		$\mu\text{s}$
	Thermal shutdown status	Normal operation, sourcing $20\ \mu\text{A}$	$(V-) + 2$			V
		Thermally shutdown			$(V-) + 0.8$	
	Current limit status	Normal operation, sourcing $20\ \mu\text{A}$	$(V-) + 0.8$			V
		Current limit flagged			$(V-) + 2$	
	Junction temperature at shutdown			160		$^{\circ}\text{C}$
	Reset temperature from shutdown			140		$^{\circ}\text{C}$
<b>POWER SUPPLY</b>						
$I_Q$	Quiescent current	$I_{LIM}$ connected to $V-$ , $I_Q = 0$		50	60	mA
	Quiescent current vs temperature	$T_A = 0^{\circ}\text{C}$ to $125^{\circ}\text{C}$		60	70	mA
	Quiescent current in shutdown mode	$I_{LIM}$ connected to $V-$			250	$\mu\text{A}$

- (1) High-speed test at  $T_J = +25^{\circ}\text{C}$ .
- (2) See text for more information on current limit accuracy.
- (3) Transient load transition time must be  $\geq 200\text{ ns}$ .
- (4)  $402\text{-k}\Omega$  pullup resistor to  $V+$  can be used to permanently enable the OPA561.

## 5.6 Typical Characteristics

at  $T_{CASE} = 25^{\circ}C$ ,  $V_S = 15 V$ , and E/S enabled (unless otherwise noted)

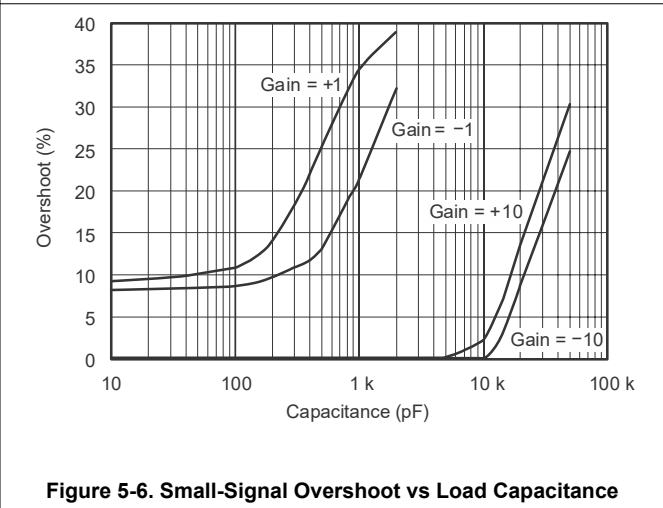
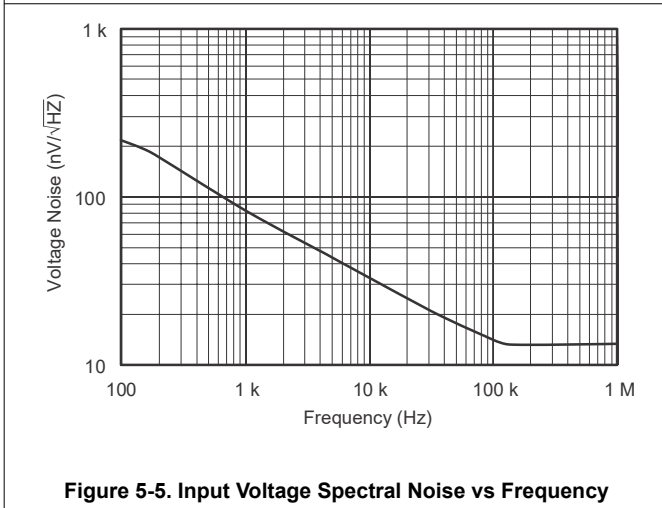
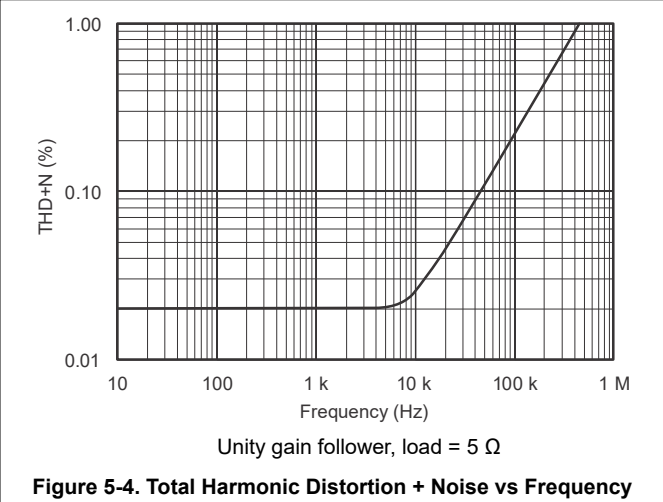
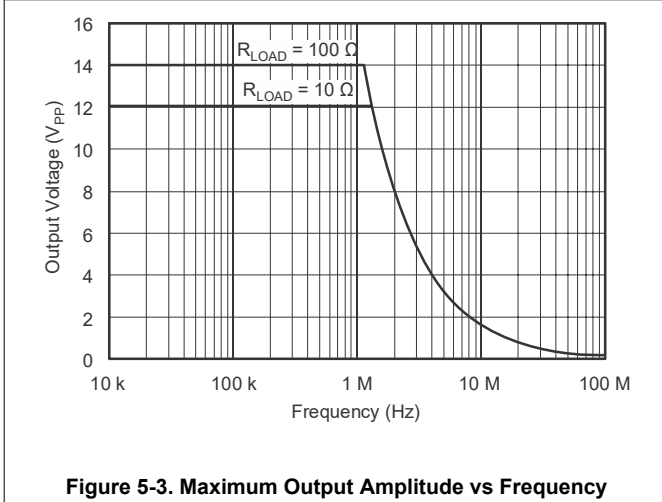
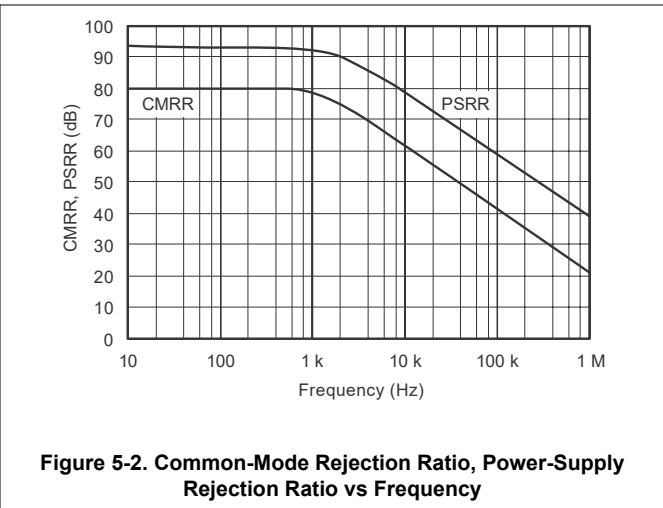
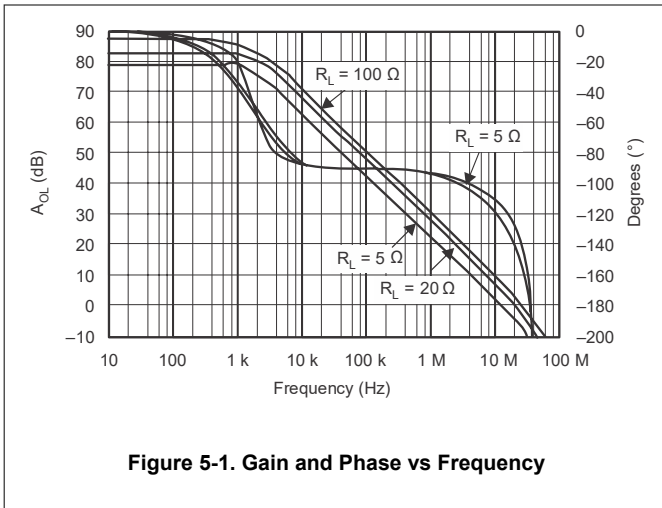

### 5.6 Typical Characteristics (continued)

at  $T_{CASE} = 25^{\circ}C$ ,  $V_S = 15 V$ , and E/S enabled (unless otherwise noted)

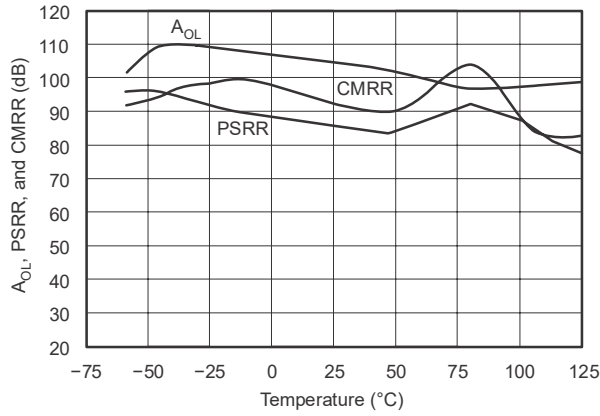

Figure 5-7.  $A_{OL}$ , PSRR, and CMRR vs Temperature

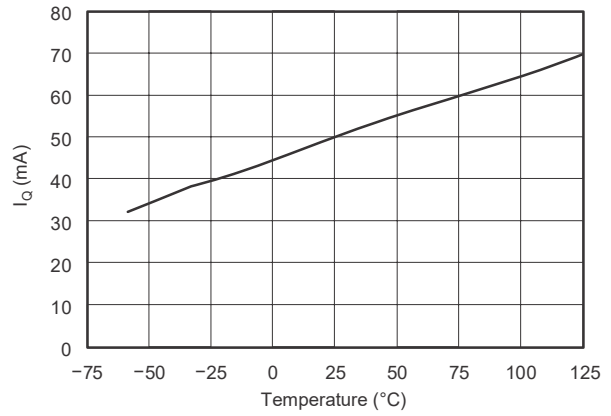

Figure 5-8.  $I_Q$  vs Temperature

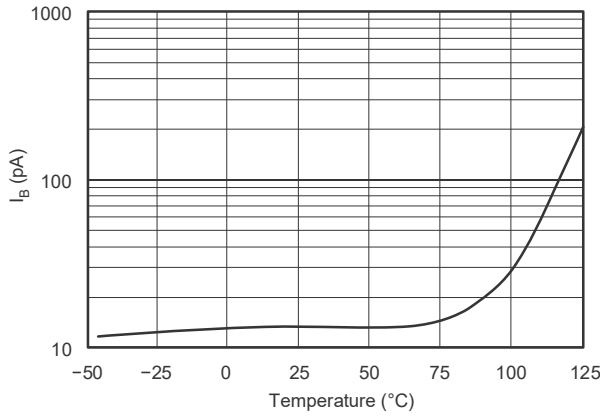

Figure 5-9.  $I_B$  vs Temperature

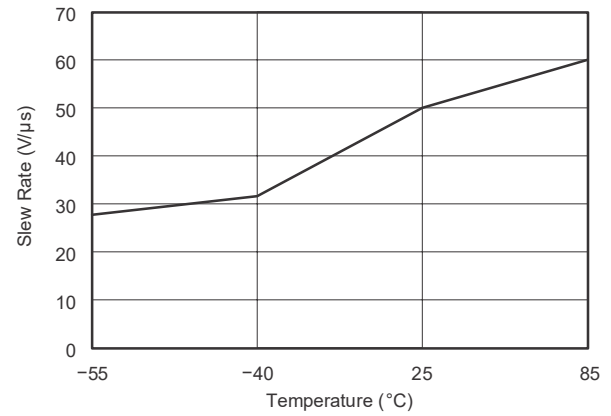

Figure 5-10. Slew Rate vs Temperature

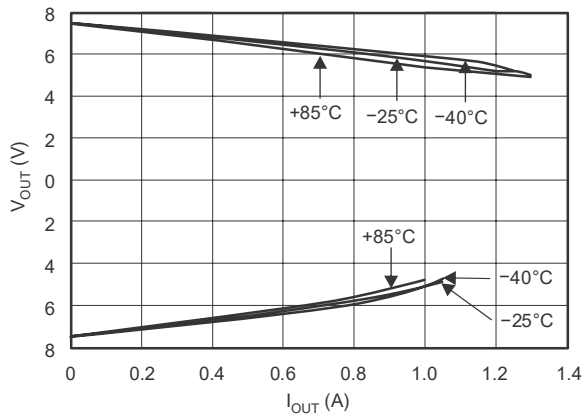

Figure 5-11. Output Voltage Swing vs Output Current

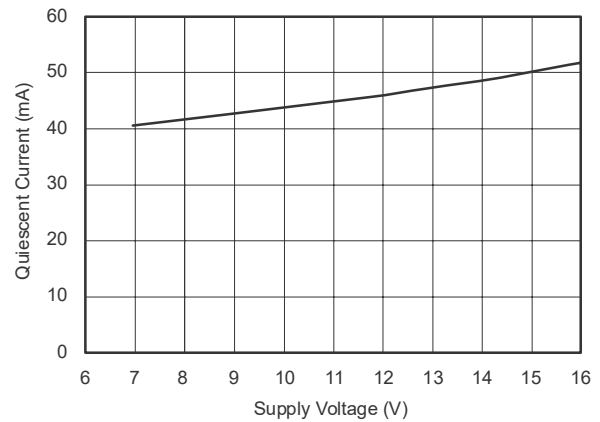
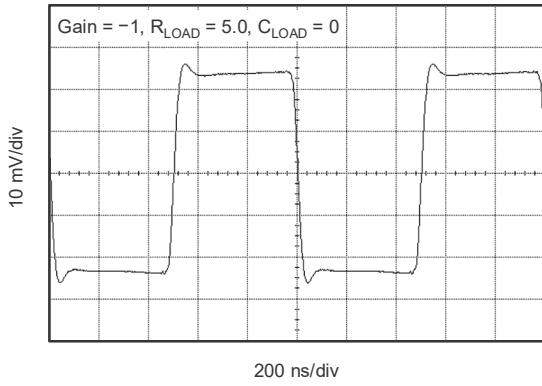

Figure 5-12. Quiescent Current vs Supply Voltage



## 5.6 Typical Characteristics (continued)

at  $T_{CASE} = 25^{\circ}C$ ,  $V_S = 15\text{ V}$ , and E/S enabled (unless otherwise noted)



**Figure 5-13. Small-Signal Step Response**

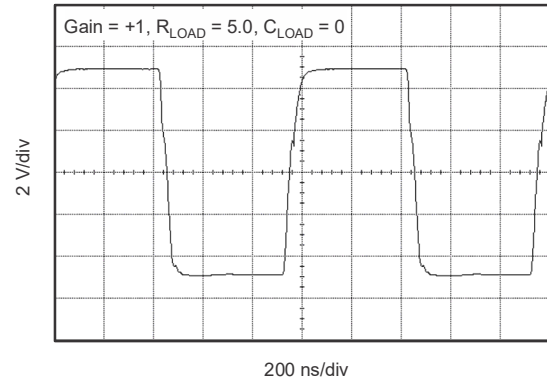

**Figure 5-14. Large-Signal Step Response**

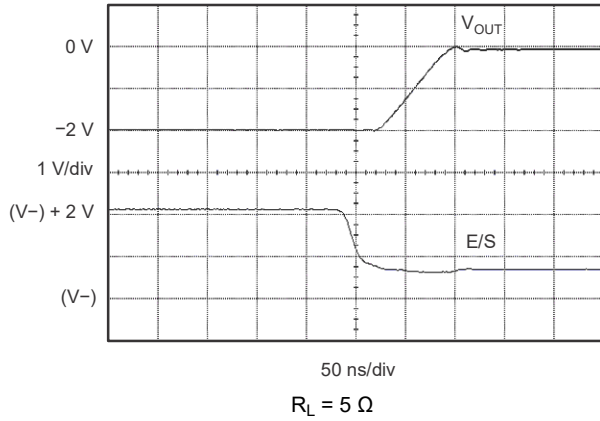

**Figure 5-15. Shutdown Response**

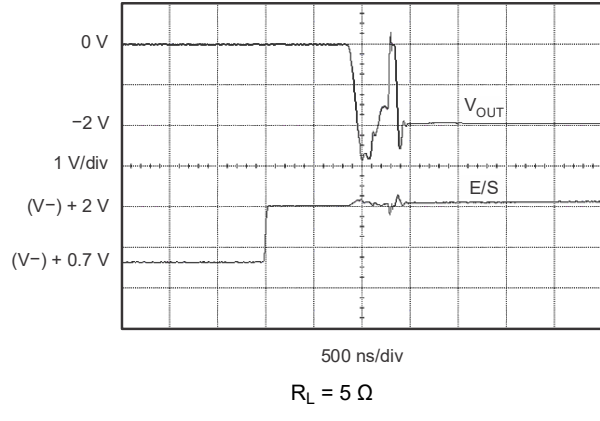

**Figure 5-16. Enable Response**

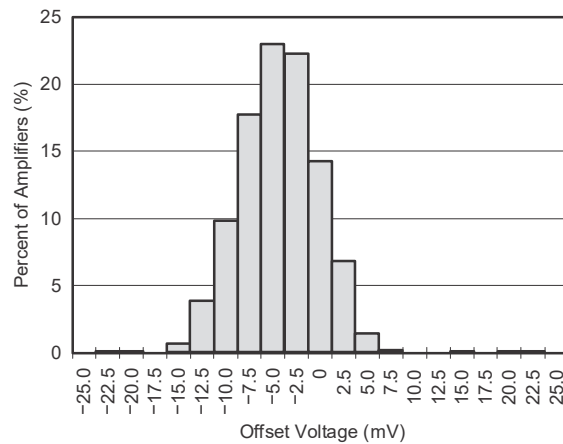

**Figure 5-17. Offset Voltage Production Distribution**

## 6 Detailed Description

### 6.1 Overview

The OPA561 is a monolithic low-cost, high-current operational amplifier capable of driving up to 1.2 A pulses into reactive loads. The amplifier is designed to provide high slew rate, which results in 1-MHz full-power bandwidth and excellent linearity. The OPA561 operates from either a single supply in the range of 7 V to 15 V or dual power supplies of  $\pm 3.5$  V to  $\pm 7.5$  V for design flexibility.

### 6.2 Feature Description

#### 6.2.1 Adjustable Current Limit

The OPA561 has an accurate, user-defined, current limit which can be set from 0.2 A to 1.2 A by controlling the input to the  $I_{LIM}$  pin. Unlike other designs that use a power resistor in series with the output current path, the OPA561 senses the load internally. This allows the current limit to be set with low-power components. In contrast, other designs require one or two expensive power resistors that can handle the full output current (1.2 A in this case).

##### 6.2.1.1 Current Limit Accuracy

The OPA561 has separate circuits to monitor the positive and negative currents. Each output is compared to a single internal reference that is set by the external current limit resistor (or voltage). The OPA561 employs a patented circuit technique to achieve an accurate and stable current limit. The output current limit has an accuracy of up to 5% on the 1-A current limit. Due to internal matching limitations, the positive and negative current limits can be slightly different. However, the values are typically within 10% of each other.

##### 6.2.1.2 Setting the Current Limit

Do not float the  $I_{LIM}$  pin or damage to the device is possible. Connect  $I_{LIM}$  directly to  $V-$  to program the maximum output current limit, typically 1.2 A. The simplest method for adjusting the current limit ( $I_{LIM}$ ) uses a resistor or potentiometer connected between the  $I_{LIM}$  pin and  $V-$  according to the following equation:

$$I_{LIM} = \left( \frac{1.2V}{R_{CL} + 10k\Omega} \right) \times 10,000 \quad (1)$$

This external resistor determines a small internal current which sets the desired output current limit. Alternatively, the output current limit can be set by applying a voltage to the  $I_{LIM}$  pin. [Figure 6-1](#) shows a simplified schematic of the OPA561 current limit.

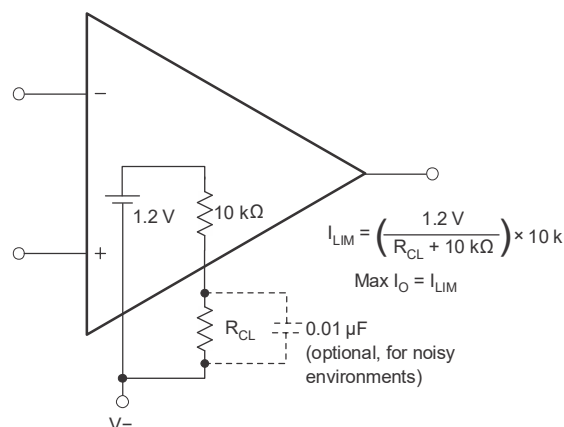

**Figure 6-1. Adjustable Current Limit — Resistor Method**

## 6.2.2 Enable-Status (E/S) Pin

The enable-status (E/S) pin provides two unique functions:

1. Output disable by forcing the pin LOW
2. Thermal shutdown indication by monitoring the voltage level at the pin

One or both of these functions can be used on the same device. For normal operation (output enabled), pull the E/S pin high (at least 2 V greater than  $V^-$ ). A small-value capacitor can be connected between the E/S pin and  $V^-$  for noisy applications. To enable the OPA561 permanently, tie the E/S pin to  $V^+$  through a 402-k $\Omega$  pullup resistor.

### 6.2.2.1 Output Disable

The shutdown pin is referenced to the negative supply ( $V^-$ ). Therefore, shutdown operation is slightly different in single-supply and dual-supply applications. In single-supply operation,  $V^-$  typically equals common ground. Therefore, the shutdown logic signal and the OPA561's shutdown pin are referenced to the same potential. In this configuration, the logic pin and the OPA561 enable can simply be tied together. Shutdown occurs for voltage levels of < 0.8 V. The OPA561 is enabled at logic levels > 2 V. In dual-supply operation, the logic pin is still referenced to a logic ground. However, the shutdown pin of the OPA561 is still referenced to  $V^-$ . To shutdown the OPA561, the voltage level of the logic signal needs to be level shifted using an optocoupler, as shown in Figure 6-2.

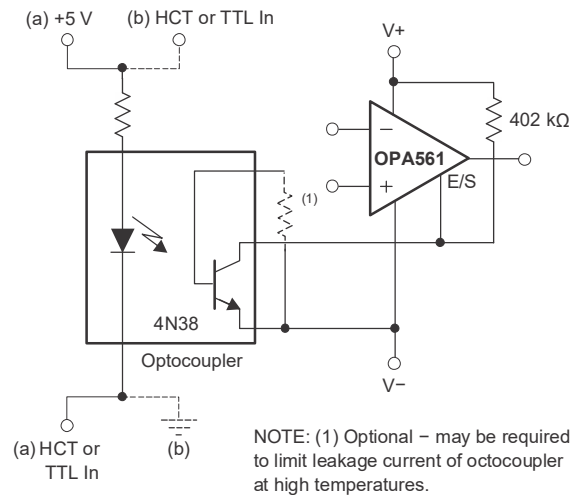

**Figure 6-2. Shutdown Configuration for Dual Supplies**

To disable the output, the E/S pin is pulled LOW, to no greater than 0.8 V above  $V^-$ . This function can be used to conserve power during idle periods. The typical time required to shut down the output is 50 ns. To return the output to an enabled state, the E/S pin can be pulled to at least 2.0 V above  $V^-$ . Typically, the output is enabled within 3  $\mu$ s. Note that pulling the E/S pin HIGH (output enabled) does not disable the internal thermal shutdown.

### 6.2.2.2 Maintaining Microcontroller Compatibility

Not all microcontrollers output the same logic state after power-up or reset. 8051-type microcontrollers, for example, output logic-high levels on the ports, whereas other models power up with logic low levels after reset. In [Figure 6-2](#), configuration (a) the shutdown signal is applied on the cathode side of the photodiode within the optocoupler. A high logic level causes the OPA561 to be enabled, and a low logic level shuts down the OPA561. In [Figure 6-2](#), configuration (b), with the logic signal applied on the anode side, a high level causes the OPA561 to shut down, and a low level enables the op amp.

### 6.2.3 Overcurrent Flag

The OPA561 features an overcurrent status flag (CLS, pin 9) that can be monitored to see if the load exceeds the current limit. The output signal of the overcurrent limit flag is compatible to standard logic. The CLS signal is referenced to  $V^-$ . A voltage level less than  $(V^-) + 0.8\text{ V}$  indicates normal operation, and a level greater than  $(V^-) + 2\text{ V}$  indicates that the OPA561 is current limited. The flag remains high as long as the output of the OPA561 current limited. At very low signal frequencies (typically  $< 1\text{ kHz}$ ), both the upper (sourcing current) and lower (sinking current) current limits are monitored. At frequencies  $> 1\text{ kHz}$ , as a result of internal circuit limitations, the flag output signal for the upper current limit becomes delayed and shortened. The flag signal for the lower current limit is unaffected by this behavior. As the signal frequency increases further, only the lower current limit (sinking current) is output on pin 9.

## 7 Application and Implementation

### Note

Information in the following applications sections is not part of the TI component specification, and TI does not warrant its accuracy or completeness. TI's customers are responsible for determining suitability of components for their purposes, as well as validating and testing their design implementation to confirm system functionality.

### 7.1 Application Information

Figure 7-1 shows the OPA561 connected as a basic noninverting amplifier. However, the OPA561 can be used in virtually any op amp configuration. Reinforce power supply terminals with low series impedance capacitors. The technique of using a ceramic and tantalum type in parallel is recommended. Low series impedance power supply wiring is recommended.

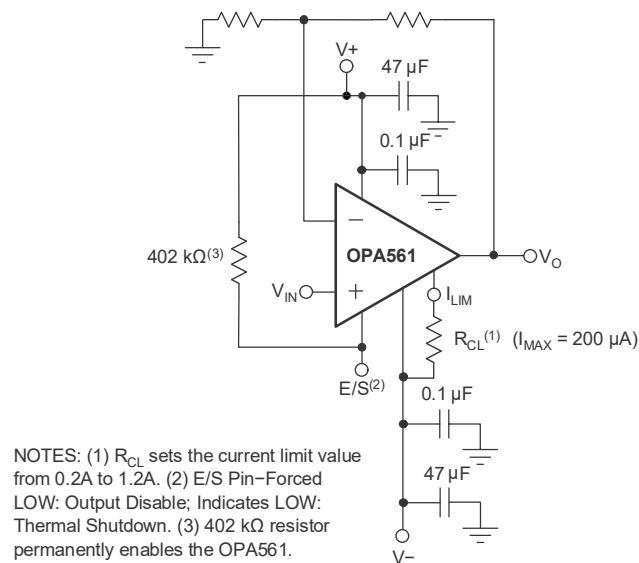

**Figure 7-1. Basic Circuit Connections**

#### 7.1.1 Output Stage Compensation

The complex load impedances common in power op amp applications can cause output stage instability. For normal operation, output compensation circuitry is typically not required. However, if the OPA561 is intended to be driven into current limit, implementing an R/C network (snubber) is recommended. A snubber circuit also helps to enhance stability when driving large capacitive loads ( $> 1000$  pF) or inductive loads (motors, loads separated from the amplifier by long cables). Typically, 3 Ω to 10 Ω in series with 0.01 μF to 0.1 μF is adequate. Varying the component values can help with challenging load conditions.

### 7.1.2 Output Protection

Reactive and EMF-generation loads can return load current to the amplifier, causing the output voltage to exceed the power-supply voltage. This damaging condition can be avoided with clamp diodes from the output terminal to the power supplies, as shown in [Figure 7-2](#). Schottky rectifier diodes with a 3 A or greater continuous rating are recommended.

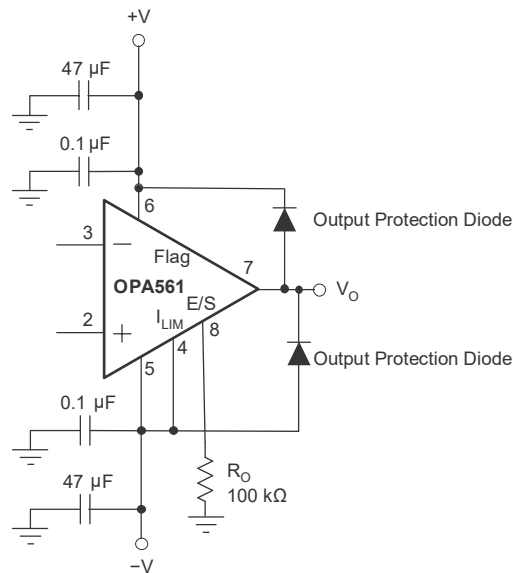

**Figure 7-2. Output Protection Diode**

### 7.1.3 Thermal Protection

The OPA561 has thermal sensing circuitry that helps protect the amplifier from exceeding temperature limits. Power dissipated in the OPA561 causes the junction temperature to rise. Internal thermal shutdown circuitry shuts down the output when the die temperature reaches approximately 160°C, resetting when the die has cooled to approximately 140°C. Depending on load and signal conditions, the thermal protection circuit can cycle on and off. This cycling limits the dissipation of the amplifier, but can have an undesirable effect on the load. Any tendency to activate the thermal protection circuit indicates excessive power dissipation or an inadequate heat sink. For reliable, long-term, continuous operation, limit the junction temperature to 125°C, maximum. To estimate the margin of safety in a complete design (including heat sink), increase the ambient temperature until the thermal protection is triggered. Use worst-case loading and signal conditions. For good, long-term reliability, set the thermal protection to trigger at more than 35°C greater than the maximum expected ambient condition of your application. This configuration produces a junction temperature of 125°C at the maximum expected ambient condition. The internal protection circuitry of the OPA561 is designed to protect against overload conditions, and is not intended to replace a proper heat sink. Continuously running the OPA561 into thermal shutdown can degrade reliability. The E/S pin can be monitored to determine if shutdown has occurred. During normal operation the voltage on the E/S pin is typically greater than  $(V-) + 2$  V. During shutdown, the voltage drops to less than  $(V-) + 0.8$  V.

### 7.1.4 Power Dissipation

Power dissipation depends on power supply, signal, and load conditions. For DC signals, power dissipation is equal to the product of output current times the voltage across the conducting output transistor. Dissipation with ac signals is lower. The [Power Amplifier Stress and Power Handling Limitations](#) application bulletin explains how to calculate or measure power dissipation with unusual signals and loads, and can be downloaded from [www.ti.com](#).

### 7.1.5 Heat-Sink Area

The relationship between thermal resistance and power dissipation can be expressed as:

$$\theta_{JA} = \frac{T_J - T_A}{P_D} \quad (2)$$

Where:

- $T_J$  = Junction temperature (°C)
- $T_A$  = Ambient temperature (°C)
- $\theta_{JA}$  = Junction-to-ambient thermal resistance (°C/W)
- $P_D$  = Power dissipation (W)

Calculate the appropriate power dissipation to determine required heat-sink area. At the same time, consider the relationship between power dissipation and thermal resistance to minimize shutdown conditions and allow for proper long-term operation (junction temperature of 125 °C). After the heat-sink area has been selected, verify proper thermal protection by testing worst-case load conditions. For applications with limited board size, refer to [Figure 7-3](#) for the approximate thermal resistance relative to heat-sink area. Increasing heat-sink area beyond 2 in<sup>2</sup> provides little improvement in thermal resistance. To achieve the 32 °C/W stated in the *Electrical Characteristics*, a copper plane size of 9 in<sup>2</sup> was used. The HTSSOP-20 PowerPAD integrated circuit package is a good choice for continuous power levels from 2 W to 4 W, depending on ambient temperature and heat-sink area. Higher power levels can be achieved in applications with a low on-off duty cycle, such as remote meter reading.

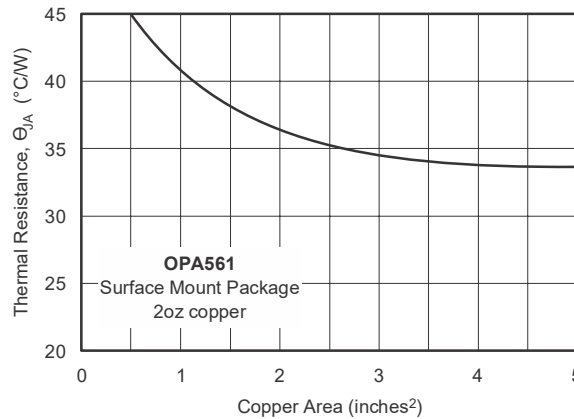

**Figure 7-3. Thermal Resistance vs Circuit Board Copper Area**

## 7.1.6 Amplifier Mounting

### 7.1.6.1 What is the PowerPAD™ Integrated Circuit Package?

The OPA561 uses the HTSSOP-20 PowerPAD integrated circuit package, a thermally enhanced, standard-size IC package designed to eliminate the use of bulky heat sinks and slugs traditionally used in thermal packages. This package can be easily mounted using standard PCB assembly techniques, and can be removed and replaced using standard repair procedures.

The PowerPAD package is designed so that the leadframe die pad (or thermal pad) is exposed on the bottom of the IC, as shown in Figure 7-4. This provides an extremely low thermal resistance ( $\theta_{JC}$ ) path between the die and the exterior of the package. The thermal pad on the bottom of the IC must be soldered directly to the PCB, using the PCB as a heat sink. In addition, through the use of thermal vias, the thermal pad can be directly connected to a ground plane or special heat sink structure designed into the PCB.

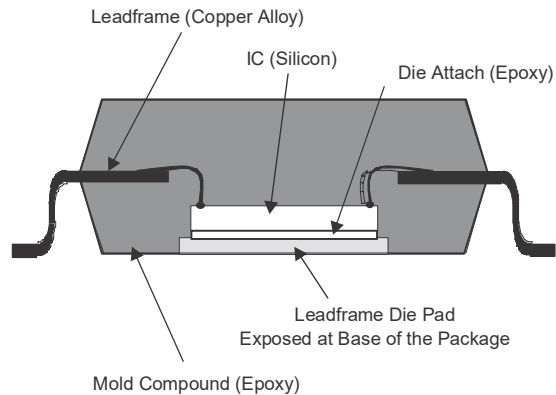

**Figure 7-4. Section View of a PowerPAD Package**

Soldering the thermal pad to the PCB is always recommended, even with applications that have low power dissipation. Soldering provides the necessary connection between the leadframe die and the PCB. Connect the thermal pad to the most negative supply of the device.



### 7.1.6.2 PowerPAD™ Integrated Circuit Package Assembly Process

1. Prepare the PCB with a top-side etch pattern, as shown in the attached *Thermal Land Pattern* mechanical drawing. Use etch for the leads as well as etch for the thermal land.
2. Place the recommended number of holes (or thermal vias) in the area of the thermal pad as shown on the attached *Land Pattern* mechanical. Use holes that are 13 mils in diameter. Keep the holes small so that solder wicking through the holes is not a problem during reflow.
3. Best practice is to place a small number of the holes under the package and outside the thermal pad area. These holes provide additional heat path between the copper land and ground plane and are 25 mils in diameter. The holes can be larger because the holes are not in the area to be soldered, so wicking is not a problem.
4. Connect all holes, including those within the thermal pad area and outside the pad area, to the internal ground plane or other internal copper plane.
5. When connecting these holes to the ground plane, do not use the typical web or spoke via connection methodology; see [Figure 7-5](#). Web connections have a high thermal resistance that is useful for slowing the heat transfer during soldering operations. This heat-transfer slowing makes the soldering of vias that have plane connections easier. However, in this application, low thermal resistance is desired for the most efficient heat transfer. Therefore, connect the holes under the PowerPAD package to the internal ground plane with a complete connection around the entire circumference of the plated through hole.
6. On the top-side solder mask, leave exposed the terminals of the package and the thermal pad area. On the thermal pad area, leave the 13 mil holes exposed. Cover the larger 25 mil holes outside the thermal pad area with solder mask.
7. Apply solder paste to the exposed thermal pad area and all of the package pins.
8. With these preparatory steps in place, the PowerPAD IC package is simply placed in position and run through the solder reflow operation, as with any standard surface-mount component. This procedure results in a part that is properly installed.

For detailed information on the PowerPAD IC package, including thermal modeling considerations and repair procedures, see the [PowerPAD Thermally Enhanced Package](#) technical brief, available at [www.ti.com](http://www.ti.com).

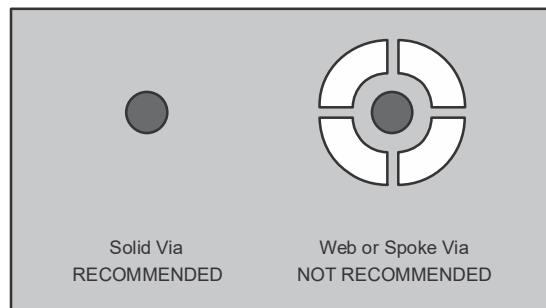

**Figure 7-5. Via Connection**

## 7.2 Typical Application

### 7.2.1 Laser Diode Driver

The high output current and low supply of the OPA561 makes this device a good candidate for driving laser diodes and thermoelectric coolers. Figure 7-6 shows the OPA561 configured as a laser diode driver.

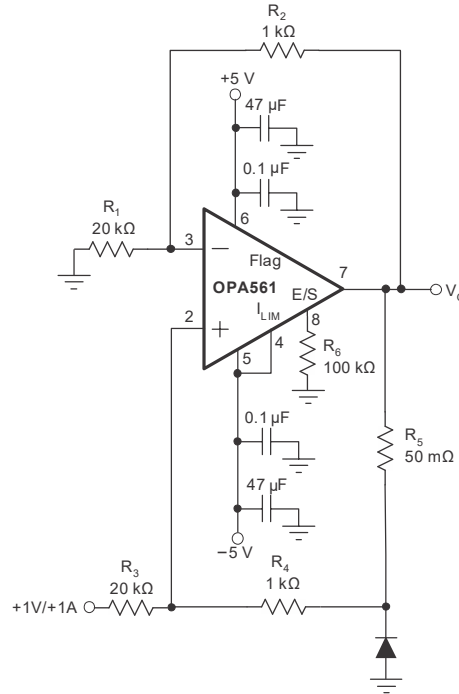

Figure 7-6. Laser Diode Driver

### 7.2.2 Programmable Power Supply

Figure 7-7 shows the OPA561 configured with the MSP430™ MCU, REF3030, and DAC7513 as a space-saving, low-cost, programmable power-supply design. This design features low-voltage operation, small-size packages, (DAC7513 in SOT23-8, REF3030 in SOT23-3) and low cost.

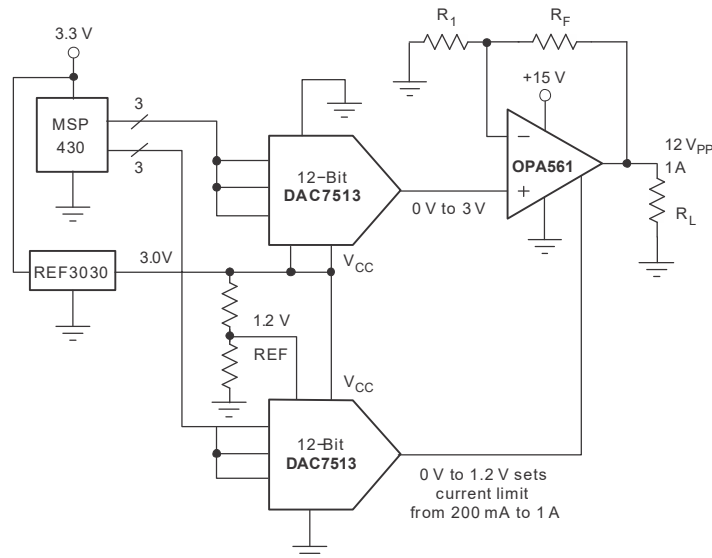
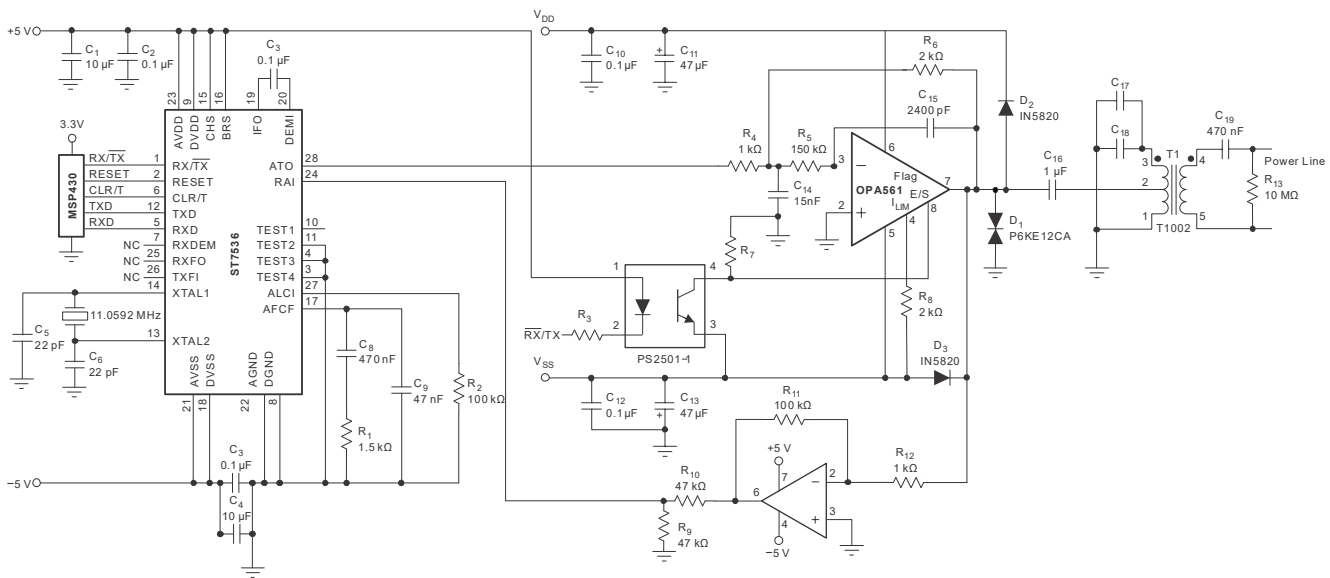

Figure 7-7. Programmable Power Supply

### 7.2.3 Power-Line Communication Modem



**Figure 7-8. Power-Line Communication Driver**

The OPA561 is an excellent choice to drive ac power lines for low-speed communication applications. The device provides an easily implemented, reliable option that is superior to discrete power transistor circuits. Advantages include:

1. Fully integrated device
2. Integrated shutdown circuitry for send-and-receive switching
3. Thermal shutdown
4. Adjustable current limit
5. Shutdown flag
6. Power savings
7. Small PowerPAD integrated circuit package

Typically such a system consists of a microcontroller, a modem IC and the power-line interface circuitry. See [Figure 7-8](#) for the half-duplex power line communication system.

The system uses a synchronous FSK-modem, capable of 600-baud and 1200-baud data rates, and supports two different FSK channels in the 60-kHz to 80-kHz range. A microcontroller such as the [MSP430™ MCU](#) is used to control the modem IC.

The OPA561 analog interface circuitry drives the FSK modem signals on the ac power line. The circuitry filters the transmit signal (ATO) from the ST7536 to suppress the 2nd-harmonic distortion of the transmit signal. The circuitry also amplifies the ATO signal and provides the very low output impedance necessary to properly drive the line. The impedance of a typical power line at 70-kHz ranges from 1 Ω to 100 Ω. The OPA561 is an excellent choice for this type of load. The transformer provides isolation and additional filtering. C9 prevents 50-Hz to 60-Hz current from flowing in the transformer. Choose this capacitor carefully for proper voltage rating and safety characteristics.

The receive input signal is amplified ( $G = 100$ ) and applied to the modem IC. The OPA561 is disabled in receive mode to avoid loading the line.

## 7.3 Power Supply Recommendations

The OPA561 operates from single (7 V to 15 V) or dual ( $\pm 3.5$  V to  $\pm 7.5$  V) supplies with excellent performance. Power-supply voltages do not need to be equal. For example, the positive supply can be set to 10 V with the negative supply at  $-5$  V, or vice-versa. Most behaviors remain unchanged throughout the operating voltage range. Parameters that vary significantly with operating voltage are shown in the *Typical Characteristics*.

## 7.4 Layout

### 7.4.1 Layout Guidelines

The OPA561 is a high-speed power amplifier that requires proper layout for best performance. Figure 7-9 shows an example of proper layout.

Keep power-supply leads as short as possible, which keeps inductance low and resistive losses at a minimum. A minimum 18-gauge wire thickness is recommended for power-supply leads. Use a wire length  $< 8$  inches.

Proper power-supply bypassing with low-ESR capacitors is essential to achieve good performance. A parallel combination of small ceramic (around 100 nF) and larger (47  $\mu$ F) nonceramic bypass capacitors provide low impedance over a wide frequency range. Place bypass capacitors as close as practical to the power-supply pins of the OPA561.

Keep PCB traces conducting high currents, such as from output to load or from the power-supply connector to the power-supply pins of the OPA561, as wide and as short as possible. This guideline helps keep inductance low and resistive losses to a minimum.

The holes in the landing pattern for the OPA561 are for the thermal vias that connect the thermal pad of the OPA561 to the heat sink area on the printed circuit board (see attached *Land Pattern* mechanical drawing). The additional larger vias further enhance the heat conduction into the heat-sink area. All traces conducting high currents are very wide for lowest inductance and minimal resistive losses. The negative supply ( $V_-$ ) pin on the OPA561 is connected through the thermal pad. This connection allows for maximum trace width for  $V_{OUT}$  and the positive power supply ( $V_+$ ).

### 7.4.2 Layout Example

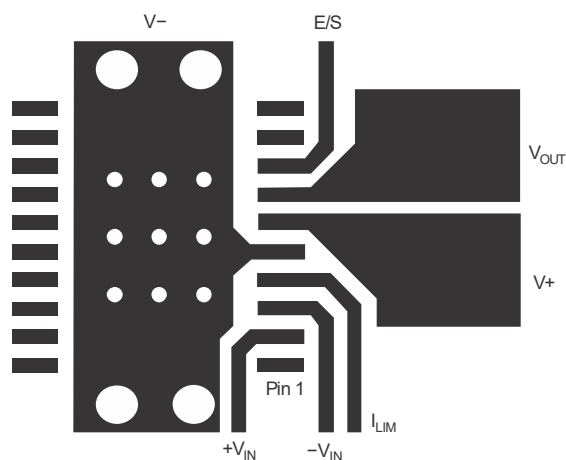

Figure 7-9. OPA561 Example Layout

## 8 Device and Documentation Support

TI offers an extensive line of development tools. Tools and software to evaluate the performance of the device, generate code, and develop solutions are listed below.

### 8.1 Device Support

#### 8.1.1 Third-Party Products Disclaimer

TI'S PUBLICATION OF INFORMATION REGARDING THIRD-PARTY PRODUCTS OR SERVICES DOES NOT CONSTITUTE AN ENDORSEMENT REGARDING THE SUITABILITY OF SUCH PRODUCTS OR SERVICES OR A WARRANTY, REPRESENTATION OR ENDORSEMENT OF SUCH PRODUCTS OR SERVICES, EITHER ALONE OR IN COMBINATION WITH ANY TI PRODUCT OR SERVICE.

### 8.2 Receiving Notification of Documentation Updates

To receive notification of documentation updates, navigate to the device product folder on [ti.com](http://ti.com). Click on *Notifications* to register and receive a weekly digest of any product information that has changed. For change details, review the revision history included in any revised document.

### 8.3 Support Resources

[TI E2E™ support forums](#) are an engineer's go-to source for fast, verified answers and design help — straight from the experts. Search existing answers or ask your own question to get the quick design help you need.

Linked content is provided "AS IS" by the respective contributors. They do not constitute TI specifications and do not necessarily reflect TI's views; see TI's [Terms of Use](#).

### 8.4 Trademarks

PowerPAD™, MSP430™, and TI E2E™ are trademarks of Texas Instruments. All trademarks are the property of their respective owners.

### 8.5 Electrostatic Discharge Caution



This integrated circuit can be damaged by ESD. Texas Instruments recommends that all integrated circuits be handled with appropriate precautions. Failure to observe proper handling and installation procedures can cause damage.

ESD damage can range from subtle performance degradation to complete device failure. Precision integrated circuits may be more susceptible to damage because very small parametric changes could cause the device not to meet its published specifications.

### 8.6 Glossary

[TI Glossary](#) This glossary lists and explains terms, acronyms, and definitions.

## 9 Revision History

NOTE: Page numbers for previous revisions may differ from page numbers in the current version.

<b>Changes from Revision E (February 2007) to Revision F (October 2023)</b>	<b>Page</b>
• Updated the numbering format for tables, figures, and cross-references throughout the document .....	1
• Added the <i>Package Information</i> table, and <i>Pin Configuration and Functions, Specifications, ESD Ratings, Recommended Operating Conditions, Thermal Information, Detailed Description, Overview, Feature Description, Application and Implementation, Typical Applications, Power Supply Recommendations, Layout, Device and Documentation Support</i> , and <i>Mechanical, Packaging, and Orderable Information</i> sections.....	1
• Changed minimum operating temperature from –40°C to 0°C throughout data sheet.....	1
• Updated input offset voltage typical value in <i>Electrical Characteristics</i> .....	5
• Updated to correct unit in Figure 6-11, <i>Output Voltage Swing vs Output Current</i> .....	7
• Updated to correct unit in Figure 6-17, <i>Offset Voltage Production Distribution</i> .....	7
• Added "approximately" to text referring to thermal protection behavior.....	14
• Added missing Equation 2.....	15

## 10 Mechanical, Packaging, and Orderable Information

The following pages include mechanical, packaging, and orderable information. This information is the most current data available for the designated devices. This data is subject to change without notice and revision of this document. For browser-based versions of this data sheet, refer to the left-hand navigation.

**PACKAGING INFORMATION**

Orderable Device	Status (1)	Package Type	Package Drawing	Pins	Package Qty	Eco Plan (2)	Lead finish/ Ball material (6)	MSL Peak Temp (3)	Op Temp (°C)	Device Marking (4/5)	Samples
OPA561PWP	ACTIVE	HTSSOP	PWP	20	70	RoHS & Green	NIPDAU	Level-2-260C-1 YEAR	0 to 125	OPA561	<a href="#">Samples</a>
OPA561PWP/2K	ACTIVE	HTSSOP	PWP	20	2000	RoHS & Green	NIPDAU	Level-2-260C-1 YEAR	0 to 125	OPA561	<a href="#">Samples</a>

(1) The marketing status values are defined as follows:

**ACTIVE:** Product device recommended for new designs.

**LIFEBUY:** TI has announced that the device will be discontinued, and a lifetime-buy period is in effect.

**NRND:** Not recommended for new designs. Device is in production to support existing customers, but TI does not recommend using this part in a new design.

**PREVIEW:** Device has been announced but is not in production. Samples may or may not be available.

**OBSOLETE:** TI has discontinued the production of the device.

(2) **RoHS:** TI defines "RoHS" to mean semiconductor products that are compliant with the current EU RoHS requirements for all 10 RoHS substances, including the requirement that RoHS substance do not exceed 0.1% by weight in homogeneous materials. Where designed to be soldered at high temperatures, "RoHS" products are suitable for use in specified lead-free processes. TI may reference these types of products as "Pb-Free".

**RoHS Exempt:** TI defines "RoHS Exempt" to mean products that contain lead but are compliant with EU RoHS pursuant to a specific EU RoHS exemption.

**Green:** TI defines "Green" to mean the content of Chlorine (Cl) and Bromine (Br) based flame retardants meet JS709B low halogen requirements of <=1000ppm threshold. Antimony trioxide based flame retardants must also meet the <=1000ppm threshold requirement.

(3) MSL, Peak Temp. - The Moisture Sensitivity Level rating according to the JEDEC industry standard classifications, and peak solder temperature.

(4) There may be additional marking, which relates to the logo, the lot trace code information, or the environmental category on the device.

(5) Multiple Device Markings will be inside parentheses. Only one Device Marking contained in parentheses and separated by a "~" will appear on a device. If a line is indented then it is a continuation of the previous line and the two combined represent the entire Device Marking for that device.

(6) Lead finish/Ball material - Orderable Devices may have multiple material finish options. Finish options are separated by a vertical ruled line. Lead finish/Ball material values may wrap to two lines if the finish value exceeds the maximum column width.

**Important Information and Disclaimer:**The information provided on this page represents TI's knowledge and belief as of the date that it is provided. TI bases its knowledge and belief on information provided by third parties, and makes no representation or warranty as to the accuracy of such information. Efforts are underway to better integrate information from third parties. TI has taken and continues to take reasonable steps to provide representative and accurate information but may not have conducted destructive testing or chemical analysis on incoming materials and chemicals. TI and TI suppliers consider certain information to be proprietary, and thus CAS numbers and other limited information may not be available for release.

In no event shall TI's liability arising out of such information exceed the total purchase price of the TI part(s) at issue in this document sold by TI to Customer on an annual basis.





**TAPE AND REEL INFORMATION**

**QUADRANT ASSIGNMENTS FOR PIN 1 ORIENTATION IN TAPE**

\*All dimensions are nominal

Device	Package Type	Package Drawing	Pins	SPQ	Reel Diameter (mm)	Reel Width W1 (mm)	A0 (mm)	B0 (mm)	K0 (mm)	P1 (mm)	W (mm)	Pin1 Quadrant
OPA561PWP/2K	HTSSOP	PWP	20	2000	330.0	16.4	6.95	7.1	1.6	8.0	16.0	Q1

**TAPE AND REEL BOX DIMENSIONS**

\*All dimensions are nominal

Device	Package Type	Package Drawing	Pins	SPQ	Length (mm)	Width (mm)	Height (mm)
OPA561PWP/2K	HTSSOP	PWP	20	2000	356.0	356.0	35.0

**TUBE**

\*All dimensions are nominal

Device	Package Name	Package Type	Pins	SPQ	L (mm)	W (mm)	T (μm)	B (mm)
OPA561PWP	PWP	HTSSOP	20	70	530	10.2	3600	3.5

# MECHANICAL DATA

PWP (R-PDSO-G20)

PowerPAD™ PLASTIC SMALL OUTLINE



4073225-4/1 05/11

- NOTES:
- All linear dimensions are in millimeters.
  - This drawing is subject to change without notice.
  - Body dimensions do not include mold flash or protrusions. Mold flash and protrusion shall not exceed 0.15 per side.
  - This package is designed to be soldered to a thermal pad on the board. Refer to Technical Brief, PowerPad Thermally Enhanced Package, Texas Instruments Literature No. SLMA002 for information regarding recommended board layout. This document is available at [www.ti.com](http://www.ti.com) <<http://www.ti.com>>.
  - See the additional figure in the Product Data Sheet for details regarding the exposed thermal pad features and dimensions.
  - Falls within JEDEC MO-153

PowerPAD is a trademark of Texas Instruments.

# THERMAL PAD MECHANICAL DATA

## PWP (R-PDSO-G20) PowerPAD™ SMALL PLASTIC OUTLINE

### THERMAL INFORMATION

This PowerPAD™ package incorporates an exposed thermal pad that is designed to be attached to a printed circuit board (PCB). The thermal pad must be soldered directly to the PCB. After soldering, the PCB can be used as a heatsink. In addition, through the use of thermal vias, the thermal pad can be attached directly to the appropriate copper plane shown in the electrical schematic for the device, or alternatively, can be attached to a special heatsink structure designed into the PCB. This design optimizes the heat transfer from the integrated circuit (IC).

For additional information on the PowerPAD package and how to take advantage of its heat dissipating abilities, refer to Technical Brief, PowerPAD Thermally Enhanced Package, Texas Instruments Literature No. SLMA002 and Application Brief, PowerPAD Made Easy, Texas Instruments Literature No. SLMA004. Both documents are available at [www.ti.com](http://www.ti.com).

The exposed thermal pad dimensions for this package are shown in the following illustration.



4206332-15/AO 01/16

NOTE: A. All linear dimensions are in millimeters

 Exposed tie strap features may not be present.

PowerPAD is a trademark of Texas Instruments

PWP (R-PDSO-G20)

PowerPAD™ PLASTIC SMALL OUTLINE

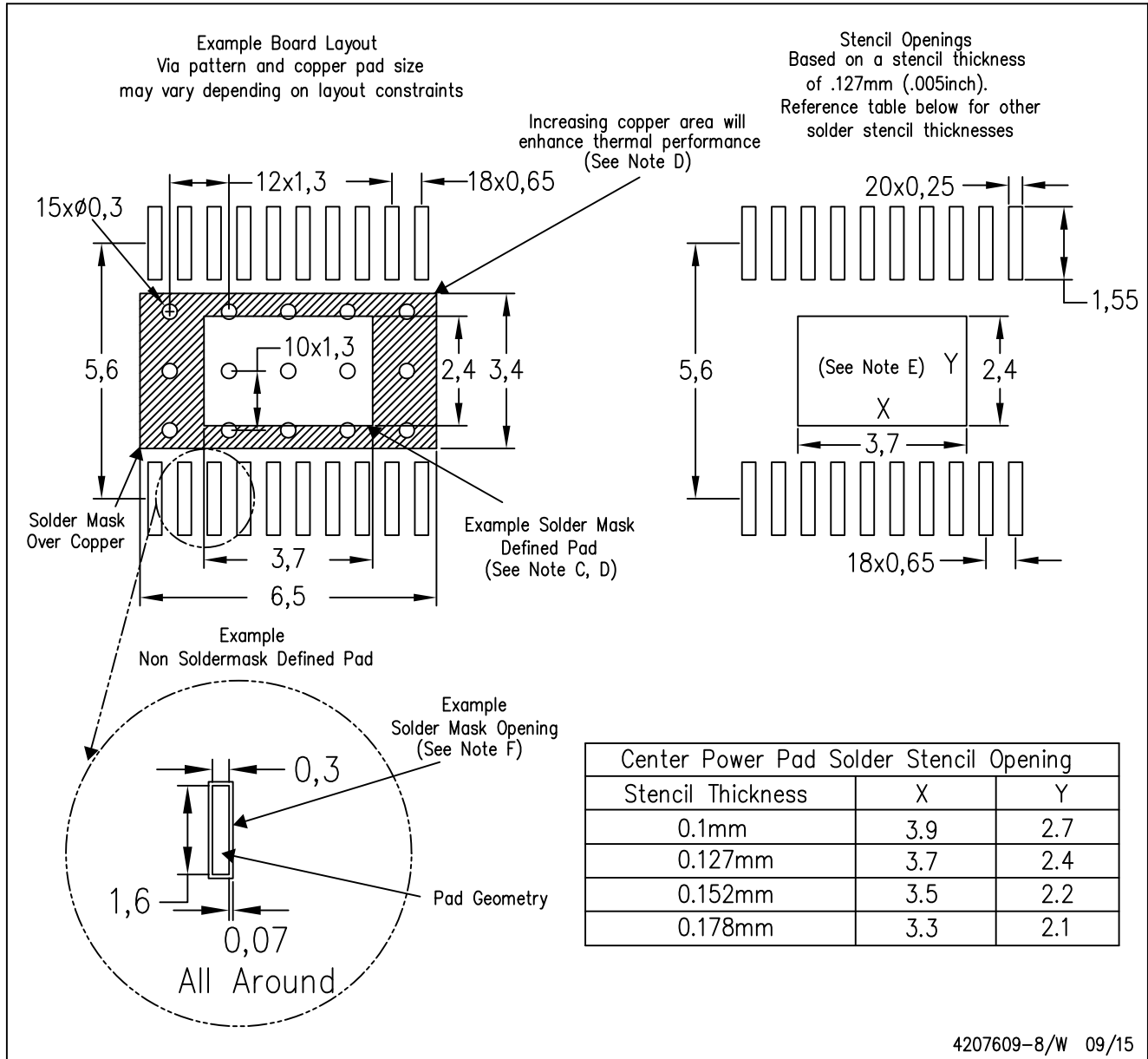

- NOTES:
- A. All linear dimensions are in millimeters.
  - B. This drawing is subject to change without notice.
  - C. Customers should place a note on the circuit board fabrication drawing not to alter the center solder mask defined pad.
  - D. This package is designed to be soldered to a thermal pad on the board. Refer to Technical Brief, PowerPad Thermally Enhanced Package, Texas Instruments Literature No. SLMA002, SLMA004, and also the Product Data Sheets for specific thermal information, via requirements, and recommended board layout. These documents are available at [www.ti.com](http://www.ti.com) <<http://www.ti.com>>. Publication IPC-7351 is recommended for alternate designs.
  - E. Laser cutting apertures with trapezoidal walls and also rounding corners will offer better paste release. Customers should contact their board assembly site for stencil design recommendations. Example stencil design based on a 50% volumetric metal load solder paste. Refer to IPC-7525 for other stencil recommendations.
  - F. Customers should contact their board fabrication site for solder mask tolerances between and around signal pads.

## IMPORTANT NOTICE AND DISCLAIMER

TI PROVIDES TECHNICAL AND RELIABILITY DATA (INCLUDING DATA SHEETS), DESIGN RESOURCES (INCLUDING REFERENCE DESIGNS), APPLICATION OR OTHER DESIGN ADVICE, WEB TOOLS, SAFETY INFORMATION, AND OTHER RESOURCES "AS IS" AND WITH ALL FAULTS, AND DISCLAIMS ALL WARRANTIES, EXPRESS AND IMPLIED, INCLUDING WITHOUT LIMITATION ANY IMPLIED WARRANTIES OF MERCHANTABILITY, FITNESS FOR A PARTICULAR PURPOSE OR NON-INFRINGEMENT OF THIRD PARTY INTELLECTUAL PROPERTY RIGHTS.

These resources are intended for skilled developers designing with TI products. You are solely responsible for (1) selecting the appropriate TI products for your application, (2) designing, validating and testing your application, and (3) ensuring your application meets applicable standards, and any other safety, security, regulatory or other requirements.

These resources are subject to change without notice. TI grants you permission to use these resources only for development of an application that uses the TI products described in the resource. Other reproduction and display of these resources is prohibited. No license is granted to any other TI intellectual property right or to any third party intellectual property right. TI disclaims responsibility for, and you will fully indemnify TI and its representatives against, any claims, damages, costs, losses, and liabilities arising out of your use of these resources.

TI's products are provided subject to [TI's Terms of Sale](#) or other applicable terms available either on [ti.com](https://www.ti.com) or provided in conjunction with such TI products. TI's provision of these resources does not expand or otherwise alter TI's applicable warranties or warranty disclaimers for TI products.

TI objects to and rejects any additional or different terms you may have proposed.

Mailing Address: Texas Instruments, Post Office Box 655303, Dallas, Texas 75265  
Copyright © 2024, Texas Instruments Incorporated