

FEATURES

- Operate From 1.65 V to 3.6 V
- Inputs Accept Voltages to 5.5 V
- Max t_{pd} of 5.9 ns at 3.3 V
- Typical V_{OLP} (Output Ground Bounce) < 0.8 V at $V_{CC} = 3.3$ V, $T_A = 25^\circ\text{C}$
- Typical V_{OHV} (Output V_{OH} Undershoot) > 2 V at $V_{CC} = 3.3$ V, $T_A = 25^\circ\text{C}$
- Support Mixed-Mode Signal Operation on All Ports (5-V Input/Output Voltage With 3.3-V V_{CC})
- I_{off} Supports Partial-Power-Down Mode Operation
- Bus Hold on Data Inputs Eliminates the Need for External Pullup/Pulldown Resistors
- Latch-Up Performance Exceeds 250 mA Per JESD 17
- ESD Protection Exceeds JESD 22
 - 2000-V Human-Body Model (A114-A)
 - 200-V Machine Model (A115-A)
 - 1000-V Charged-Device Model (C101)

SN54LVCH244A . . . J OR W PACKAGE
SN74LVCH244A . . . DB, DBQ, DGV, DW,
NS, OR PW PACKAGE
(TOP VIEW)

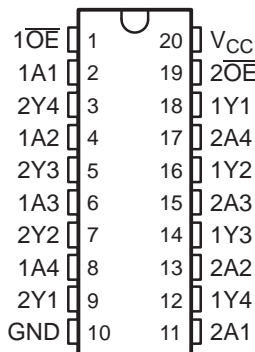

SN74LVCH244A . . . RGY PACKAGE
(TOP VIEW)

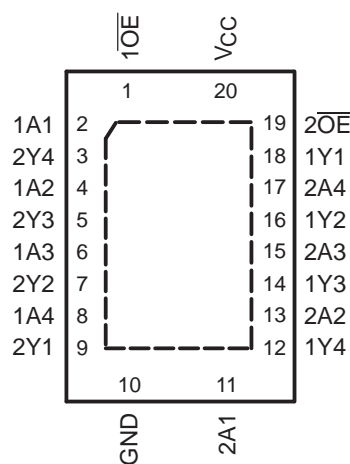

SN54LVCH244A . . . FK PACKAGE
(TOP VIEW)

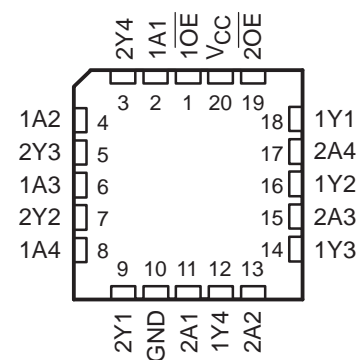

DESCRIPTION/ORDERING INFORMATION

The SN54LVCH244A octal buffer/line driver is designed for 2.7-V to 3.6-V V_{CC} operation, and the SN74LVCH244A octal buffer/line driver is designed for 1.65-V to 3.6-V V_{CC} operation.

These devices are organized as two 4-bit line drivers with separate output-enable (\overline{OE}) inputs. When \overline{OE} is low, these devices pass data from the A inputs to the Y outputs. When \overline{OE} is high, the outputs are in the high-impedance state.

Active bus-hold circuitry holds unused or undriven inputs at a valid logic state. Use of pullup or pulldown resistors with the bus-hold circuitry is not recommended.

Inputs can be driven from either 3.3-V or 5-V devices. This feature allows the use of these devices as translators in a mixed 3.3-V/5-V system environment.

These devices are fully specified for partial-power-down applications using I_{off} . The I_{off} circuitry disables the outputs, preventing damaging current backflow through the devices when they are powered down.

To ensure the high-impedance state during power up or power down, \overline{OE} should be tied to V_{CC} through a pullup resistor; the minimum value of the resistor is determined by the current-sinking capability of the driver.



Please be aware that an important notice concerning availability, standard warranty, and use in critical applications of Texas Instruments semiconductor products and disclaimers thereto appears at the end of this data sheet.

SN54LVCH244A, SN74LVCH244A OCTAL BUFFERS/DRIVERS WITH 3-STATE OUTPUTS

SCES0090–JULY 1995–REVISED FEBRUARY 2007

ORDERING INFORMATION

T _A	PACKAGE ⁽¹⁾		ORDERABLE PART NUMBER	TOP-SIDE MARKING
–40°C to 85°C	QFN – RGY	Reel of 1000	SN74LVCH244ARGYR	LCH244A
	SOIC – DW	Tube of 25	SN74LVCH244ADW	LVCH244A
		Reel of 2000	SN74LVCH244ADWR	
	SOP – NS	Reel of 2000	SN74LVCH244ANSR	LVCH244A
	SSOP – DB	Reel of 2000	SN74LVCH244ADBR	LCH244A
	SSOP (QSOP) – DBQ	Reel of 2500	SN74LVCH244ADBQR	LVCH244A
	TSSOP – PW	Tube of 70	SN74LVCH244APW	LCH244A
Reel of 2000		SN74LVCH244APWR		
Reel of 250		SN74LVCH244APWT		
TVSOP – DGV	Reel of 2000	SN74LVCH244ADGVR	LCH244A	
–55°C to 125°C	CDIP – J	Tube of 20	SNJ54LVCH244AJ	SNJ54LVCH244AJ
	CFP – W	Tube of 85	SNJ54LVCH244AW	SNJ54LVCH244AW
	LCCC – FK	Tube of 55	SNJ54LVCH244AFK	SNJ54LVCH244AFK

(1) Package drawings, standard packing quantities, thermal data, symbolization, and PCB design guidelines are available at www.ti.com/sc/package.

FUNCTION TABLE (EACH BUFFER)

INPUTS		OUTPUT Y
\overline{OE}	A	
L	H	H
L	L	L
H	X	Z

LOGIC DIAGRAM (POSITIVE LOGIC)

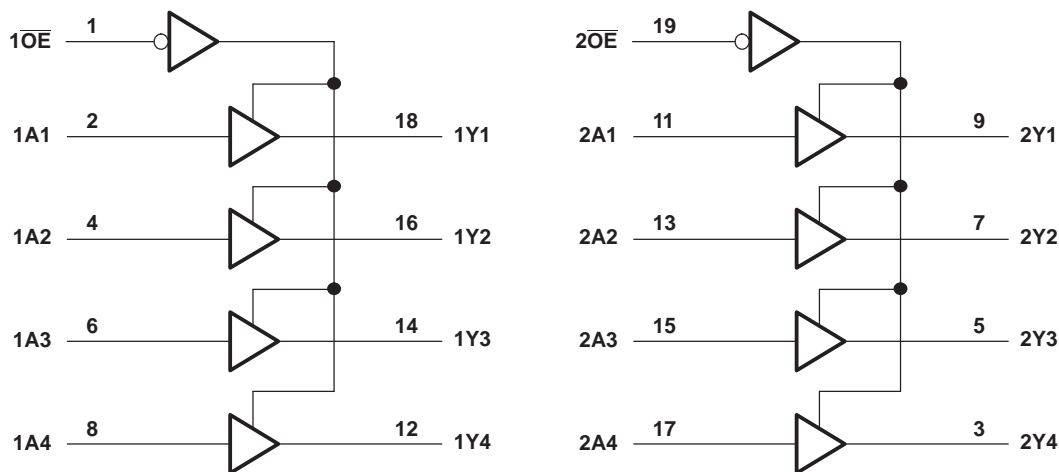

Absolute Maximum Ratings⁽¹⁾

over operating free-air temperature range (unless otherwise noted)

		MIN	MAX	UNIT
V_{CC}	Supply voltage range	–0.5	6.5	V
V_I	Input voltage range ⁽²⁾	–0.5	6.5	V
V_O	Voltage range applied to any output in the high-impedance or power-off state ⁽²⁾	–0.5	6.5	V
V_O	Voltage range applied to any output in the high or low state ⁽²⁾⁽³⁾	–0.5	$V_{CC} + 0.5$	V
I_{IK}	Input clamp current	$V_I < 0$	–50	mA
I_{OK}	Output clamp current	$V_O < 0$	–50	mA
I_O	Continuous output current		±50	mA
	Continuous current through V_{CC} or GND		±100	mA
θ_{JA}	Package thermal impedance	DB package ⁽⁴⁾	70	°C/W
		DBQ package ⁽⁴⁾	68	
		DGV package ⁽⁴⁾	92	
		DW package ⁽⁴⁾	58	
		NS package ⁽⁴⁾	60	
		PW package ⁽⁴⁾	83	
		RGY package ⁽⁵⁾	37	
T_{stg}	Storage temperature range	–65	150	°C

- (1) Stresses beyond those listed under "absolute maximum ratings" may cause permanent damage to the device. These are stress ratings only, and functional operation of the device at these or any other conditions beyond those indicated under "recommended operating conditions" is not implied. Exposure to absolute-maximum-rated conditions for extended periods may affect device reliability.
- (2) The input negative-voltage and output voltage ratings may be exceeded if the input and output current ratings are observed.
- (3) The value of V_{CC} is provided in the recommended operating conditions table.
- (4) The package thermal impedance is calculated in accordance with JESD 51-7.
- (5) The package thermal impedance is calculated in accordance with JESD 51-5.

SN54LVCH244A, SN74LVCH244A OCTAL BUFFERS/DRIVERS WITH 3-STATE OUTPUTS

SCES0090–JULY 1995–REVISED FEBRUARY 2007

Recommended Operating Conditions⁽¹⁾

		SN54LVCH244A		SN74LVCH244A		UNIT
		MIN	MAX	MIN	MAX	
V _{CC}	Supply voltage	Operating		2	3.6	V
		Data retention only		1.5		
V _{IH}	High-level input voltage	V _{CC} = 1.65 V to 1.95 V			0.65 × V _{CC}	V
		V _{CC} = 2.3 V to 2.7 V			1.7	
		V _{CC} = 2.7 V to 3.6 V		2	2	
V _{IL}	Low-level input voltage	V _{CC} = 1.65 V to 1.95 V			0.35 × V _{CC}	V
		V _{CC} = 2.3 V to 2.7 V			0.7	
		V _{CC} = 2.7 V to 3.6 V			0.8	
V _I	Input voltage	0	5.5	0	5.5	V
V _O	Output voltage	High or low state		0	V _{CC}	V
		3-state		0	5.5	
I _{OH}	High-level output current	V _{CC} = 1.65 V			–4	mA
		V _{CC} = 2.3 V			–8	
		V _{CC} = 2.7 V		–12	–12	
		V _{CC} = 3 V		–24	–24	
I _{OL}	Low-level output current	V _{CC} = 1.65 V			4	mA
		V _{CC} = 2.3 V			8	
		V _{CC} = 2.7 V		12	12	
		V _{CC} = 3 V		24	24	
Δt/Δv	Input transition rise or fall rate		10		10	ns/V
T _A	Operating free-air temperature	–55	125	–40	85	°C

(1) All unused control inputs of the device must be held at V_{CC} or GND to ensure proper device operation. Refer to the TI application report, *Implications of Slow or Floating CMOS Inputs*, literature number SCBA004.

Electrical Characteristics

over recommended operating free-air temperature range (unless otherwise noted)

PARAMETER	TEST CONDITIONS	V _{CC}	SN54LVCH244A			SN74LVCH244A			UNIT	
			MIN	TYP ⁽¹⁾	MAX	MIN	TYP ⁽¹⁾	MAX		
V _{OH}	I _{OH} = -100 μA	1.65 V to 3.6 V				V _{CC} - 0.2			V	
		2.7 V to 3.6 V	V _{CC} - 0.2							
	I _{OH} = -4 mA	1.65 V				1.2				
	I _{OH} = -8 mA	2.3 V				1.7				
	I _{OH} = -12 mA	2.7 V		2.2			2.2			
		3 V		2.4			2.4			
I _{OH} = -24 mA	3 V		2.2			2.2				
V _{OL}	I _{OL} = 100 μA	1.65 V to 3.6 V					0.2			V
		2.7 V to 3.6 V			0.2					
	I _{OL} = 4 mA	1.65 V					0.45			
	I _{OL} = 8 mA	2.3 V					0.7			
	I _{OL} = 12 mA	2.7 V			0.4		0.4			
3 V				0.55		0.55				
I _I	V _I = 0 to 5.5 V	3.6 V					±5	±5	μA	
I _{off}	V _I or V _O = 5.5 V	0						±10	μA	
I _{I(hold)}	V _I = 0.58 V	1.65 V					(2)			μA
	V _I = 1.07 V						(2)			
	V _I = 0.7 V	2.3 V					45			
	V _I = 1.7 V						-45			
	V _I = 0.8 V	3 V		75			75			
	V _I = 2 V			-75			-75			
V _I = 0 to 3.6 V ⁽³⁾	3.6 V			±500		±500				
I _{OZ}	V _O = 0 to 5.5 V	3.6 V					±15	±10	μA	
I _{CC}	V _I = V _{CC} or GND	3.6 V	I _O = 0				10	10	μA	
	3.6 V ≤ V _I ≤ 5.5 V ⁽⁴⁾						10	10	μA	
ΔI _{CC}	One input at V _{CC} - 0.6 V, Other inputs at V _{CC} or GND	2.7 V to 3.6 V				500	500	μA		
C _i	V _I = V _{CC} or GND	3.3 V				4	12	4	pF	
C _o	V _O = V _{CC} or GND	3.3 V				5.5	12	5.5	pF	

 (1) All typical values are at V_{CC} = 3.3 V, T_A = 25°C.

(2) This information was not available at the time of publication.

(3) This is the bus-hold maximum dynamic current required to switch the input from one state to another.

(4) This applies in the disabled state only.

SN54LVCH244A, SN74LVCH244A OCTAL BUFFERS/DRIVERS WITH 3-STATE OUTPUTS

SCES0090–JULY 1995–REVISED FEBRUARY 2007

Switching Characteristics

over recommended operating free-air temperature range (unless otherwise noted) (see [Figure 1](#))

PARAMETER	FROM (INPUT)	TO (OUTPUT)	SN54LVCH244A				UNIT
			$V_{CC} = 2.7\text{ V}$		$V_{CC} = 3.3\text{ V} \pm 0.3\text{ V}$		
			MIN	MAX	MIN	MAX	
t_{pd}	A	Y	7.5		1	6.5	ns
t_{en}	\overline{OE}	Y	9		1	8	ns
t_{dis}	\overline{OE}	Y	8		1	7	ns

Switching Characteristics

over recommended operating free-air temperature range (unless otherwise noted) (see [Figure 1](#))

PARAMETER	FROM (INPUT)	TO (OUTPUT)	SN74LVCH244A								UNIT
			$V_{CC} = 1.8\text{ V} \pm 0.15\text{ V}$		$V_{CC} = 2.5\text{ V} \pm 0.2\text{ V}$		$V_{CC} = 2.7\text{ V}$		$V_{CC} = 3.3\text{ V} \pm 0.3\text{ V}$		
			MIN	MAX	MIN	MAX	MIN	MAX	MIN	MAX	
t_{pd}	A	Y	(1)	(1)	(1)	(1)	6.9		1.5	5.9	ns
t_{en}	\overline{OE}	Y	(1)	(1)	(1)	(1)	8.6		1	7.6	ns
t_{dis}	\overline{OE}	Y	(1)	(1)	(1)	(1)	6.8		1.5	5.8	ns

(1) This information was not available at the time of publication.

Operating Characteristics

$T_A = 25^\circ\text{C}$

PARAMETER			TEST CONDITIONS	$V_{CC} = 1.8\text{ V}$	$V_{CC} = 2.5\text{ V}$	$V_{CC} = 3.3\text{ V}$	UNIT
				TYP	TYP	TYP	
C_{pd}	Power dissipation capacitance per buffer/driver	Outputs enabled	f = 10 MHz	(1)	(1)	47	pF
		Outputs disabled		(1)	(1)	2	

(1) This information was not available at the time of publication.

PARAMETER MEASUREMENT INFORMATION



LOAD CIRCUIT

TEST	S1
t_{PLH}/t_{PHL}	Open
t_{PLZ}/t_{PZL}	V_{LOAD}
t_{PHZ}/t_{PZH}	GND

V_{CC}	INPUTS		V_M	V_{LOAD}	C_L	R_L	V_{Δ}
	V_I	t_r/t_f					
$1.8\text{ V} \pm 0.15\text{ V}$	V_{CC}	$\leq 2\text{ ns}$	$V_{CC}/2$	$2 \times V_{CC}$	30 pF	1 k Ω	0.15 V
$2.5\text{ V} \pm 0.2\text{ V}$	V_{CC}	$\leq 2\text{ ns}$	$V_{CC}/2$	$2 \times V_{CC}$	30 pF	500 Ω	0.15 V
2.7 V	2.7 V	$\leq 2.5\text{ ns}$	1.5 V	6 V	50 pF	500 Ω	0.3 V
$3.3\text{ V} \pm 0.3\text{ V}$	2.7 V	$\leq 2.5\text{ ns}$	1.5 V	6 V	50 pF	500 Ω	0.3 V



VOLTAGE WAVEFORMS
PULSE DURATION



VOLTAGE WAVEFORMS
SETUP AND HOLD TIMES



VOLTAGE WAVEFORMS
PROPAGATION DELAY TIMES
INVERTING AND NONINVERTING OUTPUTS



VOLTAGE WAVEFORMS
ENABLE AND DISABLE TIMES
LOW- AND HIGH-LEVEL ENABLING

- NOTES:
- A. C_L includes probe and jig capacitance.
 - B. Waveform 1 is for an output with internal conditions such that the output is low, except when disabled by the output control. Waveform 2 is for an output with internal conditions such that the output is high, except when disabled by the output control.
 - C. All input pulses are supplied by generators having the following characteristics: $PRR \leq 10\text{ MHz}$, $Z_O = 50\ \Omega$.
 - D. The outputs are measured one at a time, with one transition per measurement.
 - E. t_{PLZ} and t_{PHZ} are the same as t_{dis} .
 - F. t_{PZL} and t_{PZH} are the same as t_{en} .
 - G. t_{PLH} and t_{PHL} are the same as t_{pd} .
 - H. All parameters and waveforms are not applicable to all devices.

Figure 1. Load Circuit and Voltage Waveforms

PACKAGING INFORMATION

Orderable part number	Status (1)	Material type (2)	Package Pins	Package qty Carrier	RoHS (3)	Lead finish/ Ball material (4)	MSL rating/ Peak reflow (5)	Op temp (°C)	Part marking (6)
5962-9754201Q2A	Active	Production	LCCC (FK) 20	55 TUBE	No	SNPB	N/A for Pkg Type	-55 to 125	5962- 9754201Q2A SNJ54LVCH 244AFK
5962-9754201QRA	Active	Production	CDIP (J) 20	20 TUBE	No	SNPB	N/A for Pkg Type	-55 to 125	5962-9754201QR A SNJ54LVCH244AJ
5962-9754201QSA	Active	Production	CFP (W) 20	25 TUBE	No	SNPB	N/A for Pkg Type	-55 to 125	5962-9754201QS A SNJ54LVCH244AW
5962-9754201V2A	Active	Production	LCCC (FK) 20	55 TUBE	No	SNPB	N/A for Pkg Type	-55 to 125	5962- 9754201V2A SNV54LVCH 244AFK
5962-9754201VSA	Active	Production	CFP (W) 20	25 TUBE	No	SNPB	N/A for Pkg Type	-55 to 125	5962-9754201VS A SNV54LVCH244AW
SN74LVCH244ADBQR	Active	Production	SSOP (DBQ) 20	2500 LARGE T&R	Yes	NIPDAU	Level-2-260C-1 YEAR	-40 to 85	LVCH244A
SN74LVCH244ADBQR.B	Active	Production	SSOP (DBQ) 20	2500 LARGE T&R	Yes	NIPDAU	Level-2-260C-1 YEAR	-40 to 85	LVCH244A
SN74LVCH244ADBQRG4	Active	Production	SSOP (DBQ) 20	2500 LARGE T&R	Yes	NIPDAU	Level-2-260C-1 YEAR	-40 to 85	LVCH244A
SN74LVCH244ADBQRG4.B	Active	Production	SSOP (DBQ) 20	2500 LARGE T&R	Yes	NIPDAU	Level-2-260C-1 YEAR	-40 to 85	LVCH244A
SN74LVCH244ADBR	Active	Production	SSOP (DB) 20	2000 LARGE T&R	Yes	NIPDAU	Level-1-260C-UNLIM	-40 to 85	LCH244A
SN74LVCH244ADBR.B	Active	Production	SSOP (DB) 20	2000 LARGE T&R	Yes	NIPDAU	Level-1-260C-UNLIM	-40 to 85	LCH244A
SN74LVCH244ADGVR	Active	Production	TVSOP (DGV) 20	2000 LARGE T&R	Yes	NIPDAU	Level-1-260C-UNLIM	-40 to 85	LCH244A
SN74LVCH244ADGVR.B	Active	Production	TVSOP (DGV) 20	2000 LARGE T&R	Yes	NIPDAU	Level-1-260C-UNLIM	-40 to 85	LCH244A
SN74LVCH244ADGVRG4	Active	Production	TVSOP (DGV) 20	2000 LARGE T&R	Yes	NIPDAU	Level-1-260C-UNLIM	-40 to 85	LCH244A
SN74LVCH244ADGVRG4.B	Active	Production	TVSOP (DGV) 20	2000 LARGE T&R	Yes	NIPDAU	Level-1-260C-UNLIM	-40 to 85	LCH244A
SN74LVCH244ADW	Active	Production	SOIC (DW) 20	25 TUBE	Yes	NIPDAU	Level-1-260C-UNLIM	-40 to 85	LVCH244A
SN74LVCH244ADW.B	Active	Production	SOIC (DW) 20	25 TUBE	Yes	NIPDAU	Level-1-260C-UNLIM	-40 to 85	LVCH244A
SN74LVCH244ADWR	Active	Production	SOIC (DW) 20	2000 LARGE T&R	Yes	NIPDAU	Level-1-260C-UNLIM	-40 to 85	LVCH244A
SN74LVCH244ADWR.B	Active	Production	SOIC (DW) 20	2000 LARGE T&R	Yes	NIPDAU	Level-1-260C-UNLIM	-40 to 85	LVCH244A
SN74LVCH244ADWRG4	Active	Production	SOIC (DW) 20	2000 LARGE T&R	Yes	NIPDAU	Level-1-260C-UNLIM	-40 to 85	LVCH244A

Orderable part number	Status (1)	Material type (2)	Package Pins	Package qty Carrier	RoHS (3)	Lead finish/ Ball material (4)	MSL rating/ Peak reflow (5)	Op temp (°C)	Part marking (6)
SN74LVCH244ADWRG4.B	Active	Production	SOIC (DW) 20	2000 LARGE T&R	Yes	NIPDAU	Level-1-260C-UNLIM	-40 to 85	LVCH244A
SN74LVCH244ANSR	Active	Production	SOP (NS) 20	2000 LARGE T&R	Yes	NIPDAU	Level-1-260C-UNLIM	-40 to 85	LVCH244A
SN74LVCH244ANSR.B	Active	Production	SOP (NS) 20	2000 LARGE T&R	Yes	NIPDAU	Level-1-260C-UNLIM	-40 to 85	LVCH244A
SN74LVCH244APW	Active	Production	TSSOP (PW) 20	70 TUBE	Yes	NIPDAU	Level-1-260C-UNLIM	-40 to 85	LCH244A
SN74LVCH244APW.B	Active	Production	TSSOP (PW) 20	70 TUBE	Yes	NIPDAU	Level-1-260C-UNLIM	-40 to 85	LCH244A
SN74LVCH244APWR	Active	Production	TSSOP (PW) 20	2000 LARGE T&R	Yes	NIPDAU	Level-1-260C-UNLIM	-40 to 85	LCH244A
SN74LVCH244APWR.B	Active	Production	TSSOP (PW) 20	2000 LARGE T&R	Yes	NIPDAU	Level-1-260C-UNLIM	-40 to 85	LCH244A
SN74LVCH244APWRG4	Active	Production	TSSOP (PW) 20	2000 LARGE T&R	Yes	NIPDAU	Level-1-260C-UNLIM	-40 to 85	LCH244A
SN74LVCH244APWT	Active	Production	TSSOP (PW) 20	250 SMALL T&R	Yes	NIPDAU	Level-1-260C-UNLIM	-40 to 85	LCH244A
SN74LVCH244APWT.B	Active	Production	TSSOP (PW) 20	250 SMALL T&R	Yes	NIPDAU	Level-1-260C-UNLIM	-40 to 85	LCH244A
SN74LVCH244ARGYR	Active	Production	VQFN (RGY) 20	3000 LARGE T&R	Yes	NIPDAU	Level-2-260C-1 YEAR	-40 to 85	LCH244A
SN74LVCH244ARGYR.B	Active	Production	VQFN (RGY) 20	3000 LARGE T&R	Yes	NIPDAU	Level-2-260C-1 YEAR	-40 to 85	LCH244A
SNJ54LVCH244AFK	Active	Production	LCCC (FK) 20	55 TUBE	No	SNPB	N/A for Pkg Type	-55 to 125	5962-9754201Q2A SNJ54LVCH 244AFK
SNJ54LVCH244AJ	Active	Production	CDIP (J) 20	20 TUBE	No	SNPB	N/A for Pkg Type	-55 to 125	5962-9754201QR A SNJ54LVCH244AJ
SNJ54LVCH244AW	Active	Production	CFP (W) 20	25 TUBE	No	SNPB	N/A for Pkg Type	-55 to 125	5962-9754201QS A SNJ54LVCH244AW

(1) **Status:** For more details on status, see our [product life cycle](#).

(2) **Material type:** When designated, preproduction parts are prototypes/experimental devices, and are not yet approved or released for full production. Testing and final process, including without limitation quality assurance, reliability performance testing, and/or process qualification, may not yet be complete, and this item is subject to further changes or possible discontinuation. If available for ordering, purchases will be subject to an additional waiver at checkout, and are intended for early internal evaluation purposes only. These items are sold without warranties of any kind.

(3) **RoHS values:** Yes, No, RoHS Exempt. See the [TI RoHS Statement](#) for additional information and value definition.

(4) **Lead finish/Ball material:** Parts may have multiple material finish options. Finish options are separated by a vertical ruled line. Lead finish/Ball material values may wrap to two lines if the finish value exceeds the maximum column width.

(5) **MSL rating/Peak reflow:** The moisture sensitivity level ratings and peak solder (reflow) temperatures. In the event that a part has multiple moisture sensitivity ratings, only the lowest level per JEDEC standards is shown. Refer to the shipping label for the actual reflow temperature that will be used to mount the part to the printed circuit board.

(6) **Part marking:** There may be an additional marking, which relates to the logo, the lot trace code information, or the environmental category of the part.

Multiple part markings will be inside parentheses. Only one part marking contained in parentheses and separated by a "~" will appear on a part. If a line is indented then it is a continuation of the previous line and the two combined represent the entire part marking for that device.

Important Information and Disclaimer:The information provided on this page represents TI's knowledge and belief as of the date that it is provided. TI bases its knowledge and belief on information provided by third parties, and makes no representation or warranty as to the accuracy of such information. Efforts are underway to better integrate information from third parties. TI has taken and continues to take reasonable steps to provide representative and accurate information but may not have conducted destructive testing or chemical analysis on incoming materials and chemicals. TI and TI suppliers consider certain information to be proprietary, and thus CAS numbers and other limited information may not be available for release.

In no event shall TI's liability arising out of such information exceed the total purchase price of the TI part(s) at issue in this document sold by TI to Customer on an annual basis.

OTHER QUALIFIED VERSIONS OF SN54LVCH244A, SN54LVCH244A-SP, SN74LVCH244A :

- Catalog : [SN74LVCH244A](#), [SN54LVCH244A](#)
- Military : [SN54LVCH244A](#)
- Space : [SN54LVCH244A-SP](#)

NOTE: Qualified Version Definitions:

- Catalog - TI's standard catalog product
- Military - QML certified for Military and Defense Applications
- Space - Radiation tolerant, ceramic packaging and qualified for use in Space-based application

TAPE AND REEL INFORMATION

QUADRANT ASSIGNMENTS FOR PIN 1 ORIENTATION IN TAPE

*All dimensions are nominal

Device	Package Type	Package Drawing	Pins	SPQ	Reel Diameter (mm)	Reel Width W1 (mm)	A0 (mm)	B0 (mm)	K0 (mm)	P1 (mm)	W (mm)	Pin1 Quadrant
SN74LVCH244ADBQR	SSOP	DBQ	20	2500	330.0	16.4	6.5	9.0	2.1	8.0	16.0	Q1
SN74LVCH244ADBQRG4	SSOP	DBQ	20	2500	330.0	16.4	6.5	9.0	2.1	8.0	16.0	Q1
SN74LVCH244ADBR	SSOP	DB	20	2000	330.0	16.4	8.2	7.5	2.5	12.0	16.0	Q1
SN74LVCH244ADGVR	TVSOP	DGV	20	2000	330.0	12.4	6.9	5.6	1.6	8.0	12.0	Q1
SN74LVCH244ADGVRG4	TVSOP	DGV	20	2000	330.0	12.4	6.9	5.6	1.6	8.0	12.0	Q1
SN74LVCH244ADWR	SOIC	DW	20	2000	330.0	24.4	10.8	13.3	2.7	12.0	24.0	Q1
SN74LVCH244ADWRG4	SOIC	DW	20	2000	330.0	24.4	10.8	13.3	2.7	12.0	24.0	Q1
SN74LVCH244ANSR	SOP	NS	20	2000	330.0	24.4	8.4	13.0	2.5	12.0	24.0	Q1
SN74LVCH244APWR	TSSOP	PW	20	2000	330.0	16.4	6.95	7.0	1.4	8.0	16.0	Q1
SN74LVCH244APWT	TSSOP	PW	20	250	330.0	16.4	6.95	7.0	1.4	8.0	16.0	Q1
SN74LVCH244ARGYR	VQFN	RGY	20	3000	330.0	12.4	3.71	4.71	1.1	8.0	12.0	Q1

TAPE AND REEL BOX DIMENSIONS

*All dimensions are nominal

Device	Package Type	Package Drawing	Pins	SPQ	Length (mm)	Width (mm)	Height (mm)
SN74LVCH244ADBQR	SSOP	DBQ	20	2500	353.0	353.0	32.0
SN74LVCH244ADBQRG4	SSOP	DBQ	20	2500	353.0	353.0	32.0
SN74LVCH244ADBR	SSOP	DB	20	2000	353.0	353.0	32.0
SN74LVCH244ADGVR	TVSOP	DGV	20	2000	353.0	353.0	32.0
SN74LVCH244ADGVRG4	TVSOP	DGV	20	2000	353.0	353.0	32.0
SN74LVCH244ADWR	SOIC	DW	20	2000	356.0	356.0	45.0
SN74LVCH244ADWRG4	SOIC	DW	20	2000	356.0	356.0	45.0
SN74LVCH244ANSR	SOP	NS	20	2000	356.0	356.0	45.0
SN74LVCH244APWR	TSSOP	PW	20	2000	353.0	353.0	32.0
SN74LVCH244APWT	TSSOP	PW	20	250	353.0	353.0	32.0
SN74LVCH244ARGYR	VQFN	RGY	20	3000	353.0	353.0	32.0

TUBE

*All dimensions are nominal

Device	Package Name	Package Type	Pins	SPQ	L (mm)	W (mm)	T (μm)	B (mm)
5962-9754201Q2A	FK	LCCC	20	55	506.98	12.06	2030	NA
5962-9754201V2A	FK	LCCC	20	55	506.98	12.06	2030	NA
5962-9754201VSA	W	CFP	20	25	506.98	26.16	6220	NA
SN74LVCH244ADW	DW	SOIC	20	25	507	12.83	5080	6.6
SN74LVCH244ADW.B	DW	SOIC	20	25	507	12.83	5080	6.6
SN74LVCH244APW	PW	TSSOP	20	70	530	10.2	3600	3.5
SN74LVCH244APW.B	PW	TSSOP	20	70	530	10.2	3600	3.5
SNJ54LVCH244AFK	FK	LCCC	20	55	506.98	12.06	2030	NA

W (R-GDFP-F20)

CERAMIC DUAL FLATPACK



- NOTES:
- All linear dimensions are in inches (millimeters).
 - This drawing is subject to change without notice.
 - This package can be hermetically sealed with a ceramic lid using glass frit.
 - Index point is provided on cap for terminal identification only.
 - Falls within Mil-Std 1835 GDFP2-F20

PW0020A

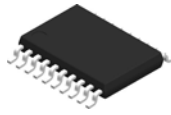

PACKAGE OUTLINE

TSSOP - 1.2 mm max height

SMALL OUTLINE PACKAGE

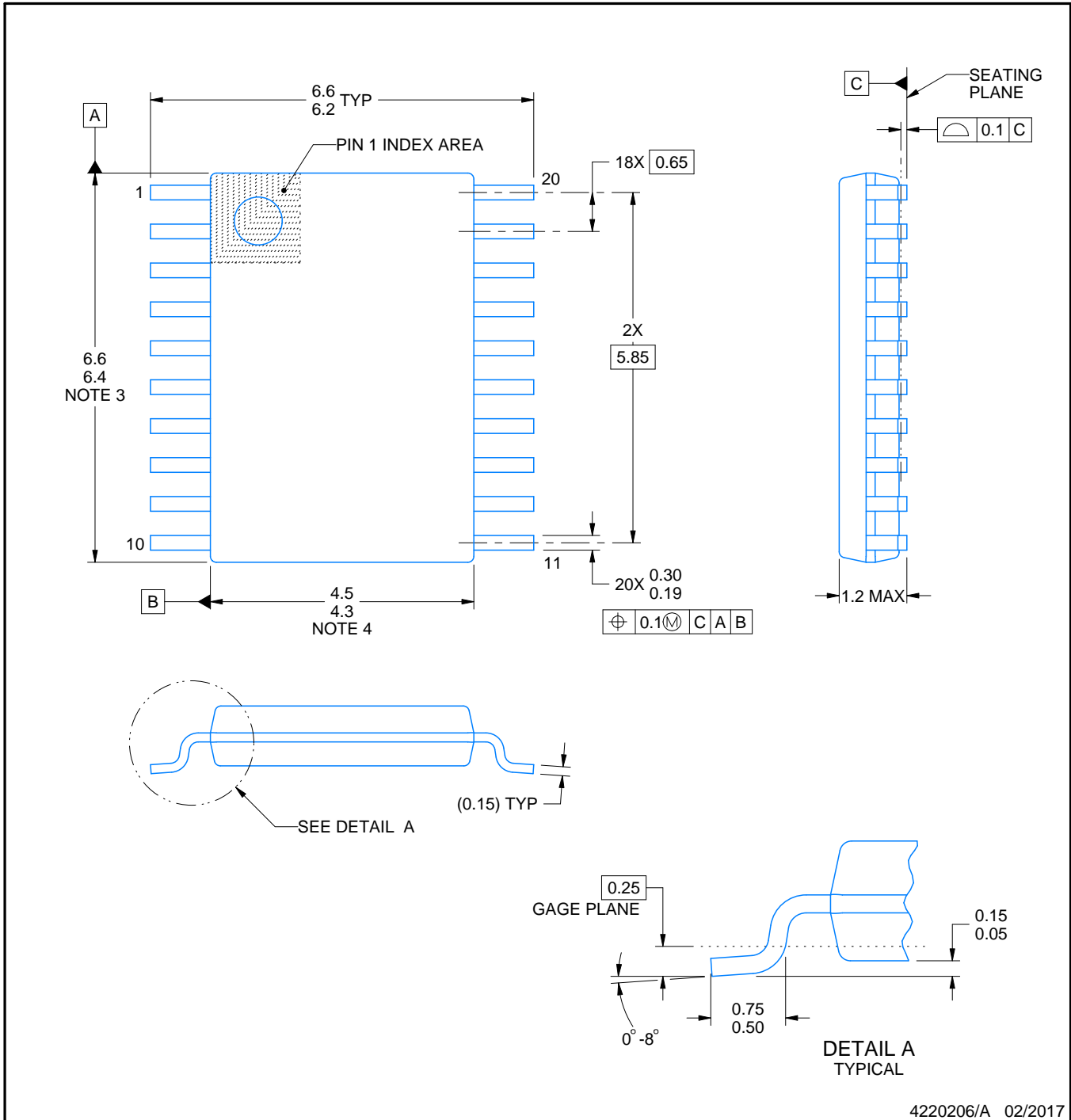

4220206/A 02/2017

NOTES:

1. All linear dimensions are in millimeters. Any dimensions in parenthesis are for reference only. Dimensioning and tolerancing per ASME Y14.5M.
2. This drawing is subject to change without notice.
3. This dimension does not include mold flash, protrusions, or gate burrs. Mold flash, protrusions, or gate burrs shall not exceed 0.15 mm per side.
4. This dimension does not include interlead flash. Interlead flash shall not exceed 0.25 mm per side.
5. Reference JEDEC registration MO-153.

EXAMPLE BOARD LAYOUT

PW0020A

TSSOP - 1.2 mm max height

SMALL OUTLINE PACKAGE



LAND PATTERN EXAMPLE
EXPOSED METAL SHOWN
SCALE: 10X



4220206/A 02/2017

NOTES: (continued)

- 6. Publication IPC-7351 may have alternate designs.
- 7. Solder mask tolerances between and around signal pads can vary based on board fabrication site.

EXAMPLE STENCIL DESIGN

PW0020A

TSSOP - 1.2 mm max height

SMALL OUTLINE PACKAGE



SOLDER PASTE EXAMPLE
BASED ON 0.125 mm THICK STENCIL
SCALE: 10X

4220206/A 02/2017

NOTES: (continued)

8. Laser cutting apertures with trapezoidal walls and rounded corners may offer better paste release. IPC-7525 may have alternate design recommendations.
9. Board assembly site may have different recommendations for stencil design.

DBQ (R-PDSO-G20)

PLASTIC SMALL-OUTLINE PACKAGE

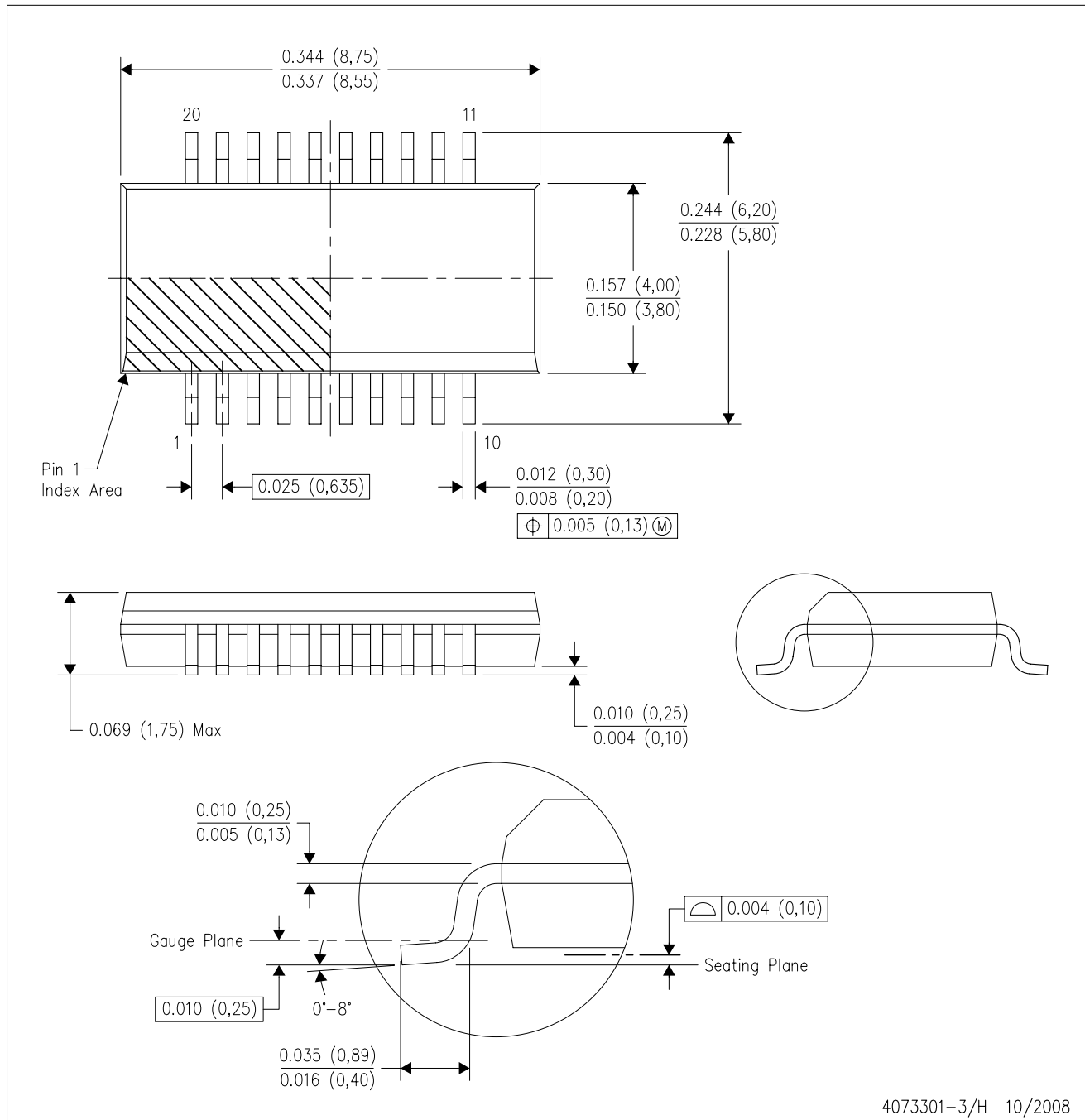

- NOTES:
- A. All linear dimensions are in inches (millimeters).
 - B. This drawing is subject to change without notice.
 - C. Body dimensions do not include mold flash or protrusion not to exceed 0.006 (0,15) per side.
 - D. Falls within JEDEC MO-137 variation AD.

DB0020A



PACKAGE OUTLINE

SSOP - 2 mm max height

SMALL OUTLINE PACKAGE



4214851/B 08/2019

NOTES:

1. All linear dimensions are in millimeters. Any dimensions in parenthesis are for reference only. Dimensioning and tolerancing per ASME Y14.5M.
2. This drawing is subject to change without notice.
3. This dimension does not include mold flash, protrusions, or gate burrs. Mold flash, protrusions, or gate burrs shall not exceed 0.15 mm per side.
4. This dimension does not include interlead flash. Interlead flash shall not exceed 0.25 mm per side.
5. Reference JEDEC registration MO-150.

EXAMPLE BOARD LAYOUT

DB0020A

SSOP - 2 mm max height

SMALL OUTLINE PACKAGE



LAND PATTERN EXAMPLE
EXPOSED METAL SHOWN
SCALE: 10X



4214851/B 08/2019

NOTES: (continued)

- Publication IPC-7351 may have alternate designs.
- Solder mask tolerances between and around signal pads can vary based on board fabrication site.

EXAMPLE STENCIL DESIGN

DB0020A

SSOP - 2 mm max height

SMALL OUTLINE PACKAGE



SOLDER PASTE EXAMPLE
BASED ON 0.125 mm THICK STENCIL
SCALE: 10X

4214851/B 08/2019

NOTES: (continued)

8. Laser cutting apertures with trapezoidal walls and rounded corners may offer better paste release. IPC-7525 may have alternate design recommendations.
9. Board assembly site may have different recommendations for stencil design.

MECHANICAL DATA

NS (R-PDSO-G**)

PLASTIC SMALL-OUTLINE PACKAGE

14-PINS SHOWN



- NOTES:
- A. All linear dimensions are in millimeters.
 - B. This drawing is subject to change without notice.
 - C. Body dimensions do not include mold flash or protrusion, not to exceed 0,15.

J (R-GDIP-T**)

14 LEADS SHOWN

CERAMIC DUAL IN-LINE PACKAGE



DIM \ PINS **	14	16	18	20
A	0.300 (7,62) BSC	0.300 (7,62) BSC	0.300 (7,62) BSC	0.300 (7,62) BSC
B MAX	0.785 (19,94)	.840 (21,34)	0.960 (24,38)	1.060 (26,92)
B MIN	—	—	—	—
C MAX	0.300 (7,62)	0.300 (7,62)	0.310 (7,87)	0.300 (7,62)
C MIN	0.245 (6,22)	0.245 (6,22)	0.220 (5,59)	0.245 (6,22)



4040083/F 03/03

- NOTES:
- All linear dimensions are in inches (millimeters).
 - This drawing is subject to change without notice.
 - This package is hermetically sealed with a ceramic lid using glass frit.
 - Index point is provided on cap for terminal identification only on press ceramic glass frit seal only.
 - Falls within MIL STD 1835 GDIP1-T14, GDIP1-T16, GDIP1-T18 and GDIP1-T20.

DGV (R-PDSO-G**)

PLASTIC SMALL-OUTLINE

24 PINS SHOWN



- NOTES: A. All linear dimensions are in millimeters.
 B. This drawing is subject to change without notice.
 C. Body dimensions do not include mold flash or protrusion, not to exceed 0,15 per side.
 D. Falls within JEDEC: 24/48 Pins – MO-153
 14/16/20/56 Pins – MO-194

GENERIC PACKAGE VIEW

RGY 20

VQFN - 1 mm max height

3.5 x 4.5, 0.5 mm pitch

PLASTIC QUAD FGLATPACK - NO LEAD

This image is a representation of the package family, actual package may vary.
Refer to the product data sheet for package details.



4225264/A

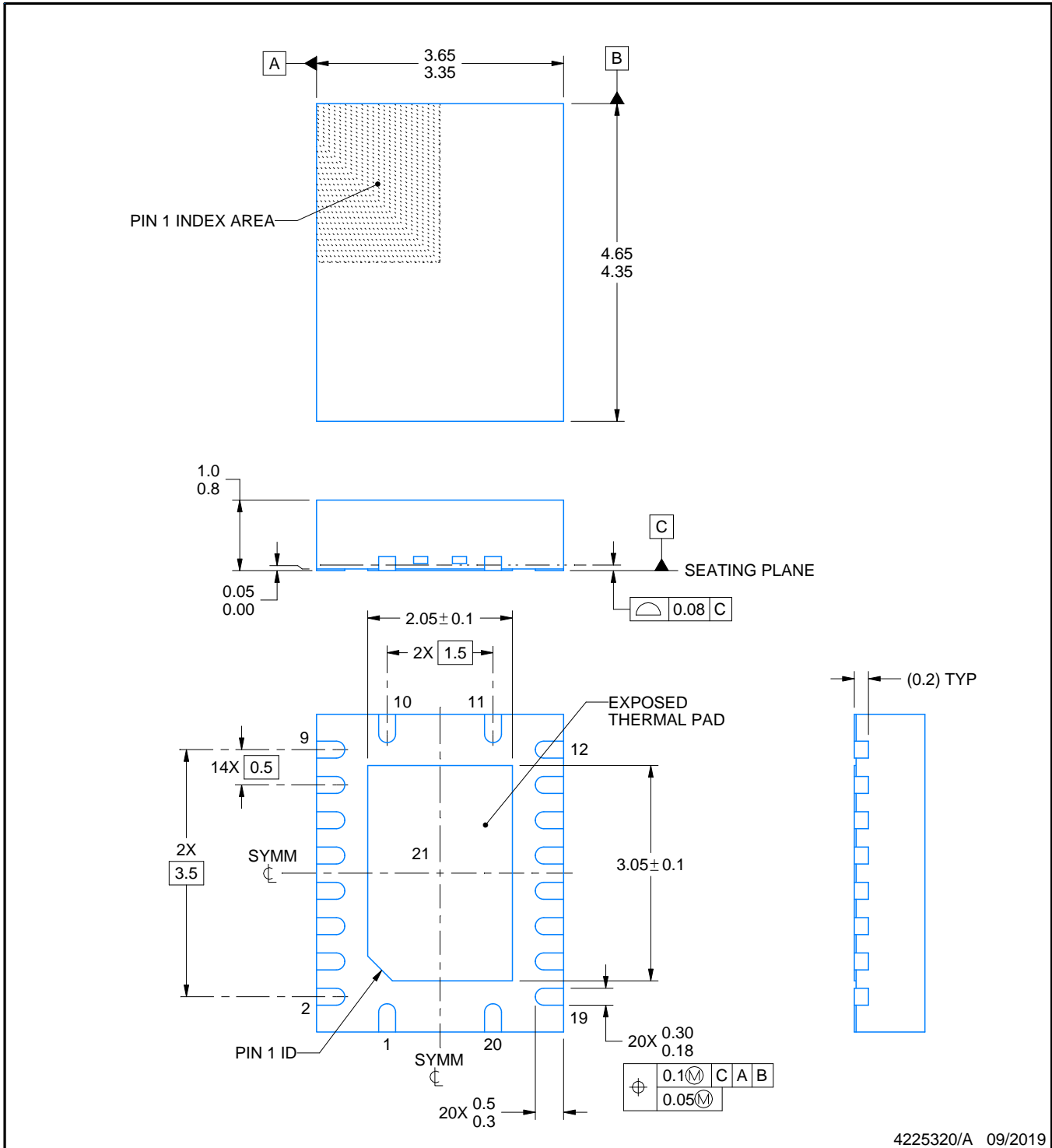

4225320/A 09/2019

NOTES:

1. All linear dimensions are in millimeters. Any dimensions in parenthesis are for reference only. Dimensioning and tolerancing per ASME Y14.5M.
2. This drawing is subject to change without notice.
3. The package thermal pad must be soldered to the printed circuit board for thermal and mechanical performance.

EXAMPLE BOARD LAYOUT

RGY0020A

VQFN - 1 mm max height

PLASTIC QUAD FLATPACK - NO LEAD



LAND PATTERN EXAMPLE
EXPOSED METAL SHOWN
SCALE:18X



SOLDER MASK DETAILS

4225320/A 09/2019

NOTES: (continued)

- This package is designed to be soldered to a thermal pad on the board. For more information, see Texas Instruments literature number SLUA271 (www.ti.com/lit/slua271).
- Vias are optional depending on application, refer to device data sheet. If any vias are implemented, refer to their locations shown on this view. It is recommended that vias under paste be filled, plugged or tented.

EXAMPLE STENCIL DESIGN

RGY0020A

VQFN - 1 mm max height

PLASTIC QUAD FLATPACK - NO LEAD



SOLDER PASTE EXAMPLE
 BASED ON 0.125 mm THICK STENCIL

EXPOSED PAD 21
 78% PRINTED SOLDER COVERAGE BY AREA UNDER PACKAGE
 SCALE:20X

4225320/A 09/2019

NOTES: (continued)

6. Laser cutting apertures with trapezoidal walls and rounded corners may offer better paste release. IPC-7525 may have alternate design recommendations.

GENERIC PACKAGE VIEW

FK 20

LCCC - 2.03 mm max height

8.89 x 8.89, 1.27 mm pitch

LEADLESS CERAMIC CHIP CARRIER

This image is a representation of the package family, actual package may vary.
Refer to the product data sheet for package details.



4229370VA\

DW0020A



PACKAGE OUTLINE

SOIC - 2.65 mm max height

SOIC



4220724/A 05/2016

NOTES:

1. All linear dimensions are in millimeters. Dimensions in parenthesis are for reference only. Dimensioning and tolerancing per ASME Y14.5M.
2. This drawing is subject to change without notice.
3. This dimension does not include mold flash, protrusions, or gate burrs. Mold flash, protrusions, or gate burrs shall not exceed 0.15 mm per side.
4. This dimension does not include interlead flash. Interlead flash shall not exceed 0.43 mm per side.
5. Reference JEDEC registration MS-013.

EXAMPLE BOARD LAYOUT

DW0020A

SOIC - 2.65 mm max height

SOIC



LAND PATTERN EXAMPLE
SCALE:6X



SOLDER MASK DETAILS

4220724/A 05/2016

NOTES: (continued)

- 6. Publication IPC-7351 may have alternate designs.
- 7. Solder mask tolerances between and around signal pads can vary based on board fabrication site.

EXAMPLE STENCIL DESIGN

DW0020A

SOIC - 2.65 mm max height

SOIC



SOLDER PASTE EXAMPLE
BASED ON 0.125 mm THICK STENCIL
SCALE:6X

4220724/A 05/2016

NOTES: (continued)

- 8. Laser cutting apertures with trapezoidal walls and rounded corners may offer better paste release. IPC-7525 may have alternate design recommendations.
- 9. Board assembly site may have different recommendations for stencil design.

IMPORTANT NOTICE AND DISCLAIMER

TI PROVIDES TECHNICAL AND RELIABILITY DATA (INCLUDING DATASHEETS), DESIGN RESOURCES (INCLUDING REFERENCE DESIGNS), APPLICATION OR OTHER DESIGN ADVICE, WEB TOOLS, SAFETY INFORMATION, AND OTHER RESOURCES "AS IS" AND WITH ALL FAULTS, AND DISCLAIMS ALL WARRANTIES, EXPRESS AND IMPLIED, INCLUDING WITHOUT LIMITATION ANY IMPLIED WARRANTIES OF MERCHANTABILITY, FITNESS FOR A PARTICULAR PURPOSE OR NON-INFRINGEMENT OF THIRD PARTY INTELLECTUAL PROPERTY RIGHTS.

These resources are intended for skilled developers designing with TI products. You are solely responsible for (1) selecting the appropriate TI products for your application, (2) designing, validating and testing your application, and (3) ensuring your application meets applicable standards, and any other safety, security, regulatory or other requirements.

These resources are subject to change without notice. TI grants you permission to use these resources only for development of an application that uses the TI products described in the resource. Other reproduction and display of these resources is prohibited. No license is granted to any other TI intellectual property right or to any third party intellectual property right. TI disclaims responsibility for, and you fully indemnify TI and its representatives against any claims, damages, costs, losses, and liabilities arising out of your use of these resources.

TI's products are provided subject to [TI's Terms of Sale](#), [TI's General Quality Guidelines](#), or other applicable terms available either on ti.com or provided in conjunction with such TI products. TI's provision of these resources does not expand or otherwise alter TI's applicable warranties or warranty disclaimers for TI products. Unless TI explicitly designates a product as custom or customer-specified, TI products are standard, catalog, general purpose devices.

TI objects to and rejects any additional or different terms you may propose.

Copyright © 2026, Texas Instruments Incorporated

Last updated 10/2025