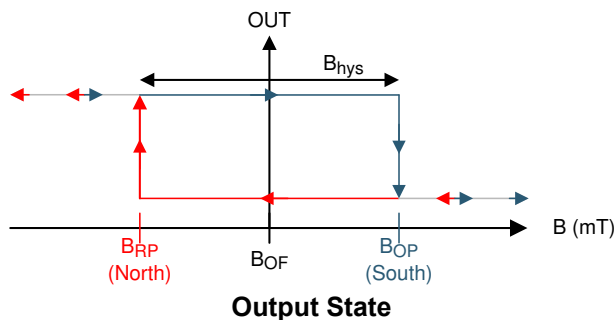


# DRV5013-Q1 Automotive, Digital-Latch Hall Effect Sensor

## 1 Features

- AEC-Q100 qualified for automotive applications:
  - DRV5013xxQ grade 1:  $T_A = -40^{\circ}\text{C}$  to  $125^{\circ}\text{C}$  (see [Device Nomenclature](#))
  - DRV5013xxE grade 0:  $T_A = -40^{\circ}\text{C}$  to  $150^{\circ}\text{C}$  (see [Device Nomenclature](#))
- Digital bipolar-latch Hall sensor
- Superior temperature stability
  - $B_{OP} \pm 10\%$  over temperature
- Multiple sensitivity options ( $B_{OP} / B_{RP}$ )
  - $\pm 1.3$  mT (FA, see [Device Nomenclature](#))
  - $\pm 2.7$  mT (AD, see [Device Nomenclature](#))
  - $\pm 6$  mT (AG, see [Device Nomenclature](#))
  - $\pm 12$  mT (BC, see [Device Nomenclature](#))
- Supports a wide voltage range
  - 2.7 V to 38 V
  - No external regulator required
- Open-drain output (30-mA sink)
- Fast 35- $\mu\text{s}$  power-on time
- Small package and footprint
  - Surface mount 3-pin SOT-23 (DBZ)
    - 2.92 mm  $\times$  2.37 mm
  - Through-hole 3-pin TO-92 (LPG)
    - 4.00 mm  $\times$  3.15 mm
- **Protection features:**
  - Reverse supply protection (up to  $-22$  V)
  - Supports up to 40-V load dump
  - Output short-circuit protection
  - Output current limitation
  - OUT short to battery protection



## 2 Applications

- Power tools
- Flow meters
- Valve and solenoid status
- Brushless dc motors
- Proximity sensing
- Tachometers

## 3 Description

The DRV5013-Q1 device is a chopper-stabilized Hall effect sensor that offers a magnetic sensing solution with superior sensitivity stability over temperature and integrated protection features.

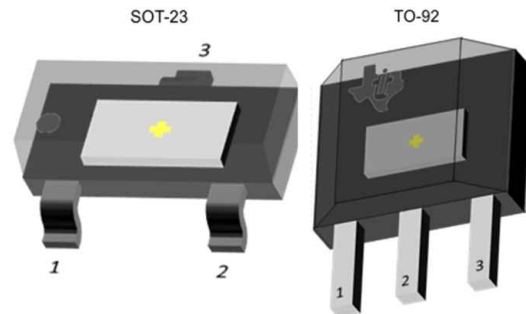
The magnetic field is indicated through a digital bipolar latch output. The IC has an open-drain output stage with 30-mA current sink capability. A wide operating voltage range from 2.7 V to 38 V with reverse polarity protection up to  $-22$  V makes the device suitable for a wide range of automotive applications.

Internal protection functions are provided for reverse supply conditions, load dump, and output short circuit or overcurrent.

### Package Information<sup>(1)</sup>

PART NUMBER	PACKAGE	BODY SIZE (NOM)
DRV5013-Q1	SOT-23 (3)	2.92 mm $\times$ 1.30 mm
	TO-92 (3)	4.00 mm $\times$ 3.15 mm

- (1) For all available packages, see the package option addendum at the end of the data sheet.



Device Packages



## Table of Contents

<b>1 Features</b> .....	1	7.3 Feature Description.....	10
<b>2 Applications</b> .....	1	7.4 Device Functional Modes.....	14
<b>3 Description</b> .....	1	<b>8 Application and Implementation</b> .....	15
<b>4 Revision History</b> .....	2	8.1 Application Information.....	15
<b>5 Pin Configuration and Functions</b> .....	3	8.2 Typical Applications.....	15
<b>6 Specifications</b> .....	4	8.3 Power Supply Recommendations.....	18
6.1 Absolute Maximum Ratings.....	4	8.4 Layout.....	18
6.2 ESD Ratings.....	4	<b>9 Device and Documentation Support</b> .....	19
6.3 Recommended Operating Conditions.....	4	9.1 Device Support.....	19
6.4 Thermal Information.....	4	9.2 Receiving Notification of Documentation Updates... 19	
6.5 Electrical Characteristics.....	5	9.3 Support Resources.....	20
6.6 Switching Characteristics.....	5	9.4 Trademarks.....	20
6.7 Magnetic Characteristics.....	6	9.5 Electrostatic Discharge Caution.....	20
6.8 Typical Characteristics.....	7	9.6 Glossary.....	20
<b>7 Detailed Description</b> .....	9	<b>10 Mechanical, Packaging, and Orderable Information</b> .....	20
7.1 Overview.....	9		
7.2 Functional Block Diagram.....	9		

### 4 Revision History

NOTE: Page numbers for previous revisions may differ from page numbers in the current version.

<b>Changes from Revision H (August 2018) to Revision I (February 2023)</b>	<b>Page</b>
• Updated the numbering format for tables, figures, and cross-references throughout the document .....	1
• Changed table title from: Device Information to: Package Information .....	1
• Moved the <i>Power Supply Recommendations</i> and <i>Layout</i> sections to the <i>Application and Implementation</i> section .....	18
<b>Changes from Revision G (October 2017) to Revision H (August 2018)</b>	<b>Page</b>
• Changed <i>Power Supply Recommendations</i> section .....	18
<b>Changes from Revision F (September 2016) to Revision G (October 2017)</b>	<b>Page</b>
• Changed location of automotive-specific Features bullets to top of Features section .....	1
• Added device HBM and CDM classification sub-bullets to automotive-specific <i>Features</i> bullet .....	1
• Added last sentence to <i>Device Functional Modes</i> section .....	14
<b>Changes from Revision E (August 2016) to Revision F (September 2016)</b>	<b>Page</b>
• Made changes to the Power-on time in the <i>Electrical Characteristics</i> table.....	5
<b>Changes from Revision D (June 2016) to Revision E (August 2016)</b>	<b>Page</b>
• Revised preliminary limits for FA version in the <i>Magnetic Characteristics</i> table.....	6
• Added the <i>Layout</i> section.....	18
<b>Changes from Revision C (May 2016) to Revision D (June 2016)</b>	<b>Page</b>
• Revised preliminary limits for the FA version.....	6
<b>Changes from Revision B (February 2016) to Revision C (May 2016)</b>	<b>Page</b>
• Revised preliminary limits for the FA version .....	6
<b>Changes from Revision A (December 2015) to Revision B (February 2016)</b>	<b>Page</b>
• Added the FA device option.....	1
• Added the typical bandwidth value to the <i>Magnetic Characteristics</i> table.....	6

**Changes from Revision \* (December 2014) to Revision A (June 2015)** **Page**

- Corrected body size of SOT-23 package and SIP package name to TO-92 ..... 1
- Added B<sub>MAX</sub> to *Absolute Maximum Ratings* ..... 4
- Removed table notes regarding testing for the operating junction temperature in *Absolute Maximum Ratings* .  
4
- Added *Community Resources* ..... 19
- Updated package tape and reel options for M and blank ..... 19

**5 Pin Configuration and Functions**

For additional configuration information, see [Device Markings](#) and [Mechanical, Packaging, and Orderable Information](#).

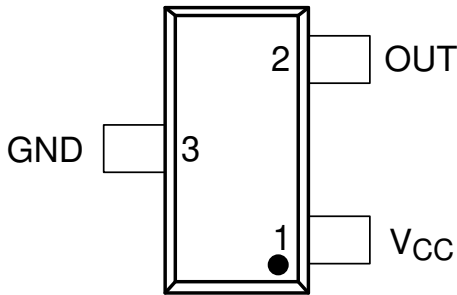


Figure 5-1. DBZ Package 3-Pin SOT-23 Top View

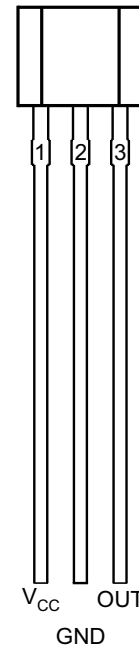


Figure 5-2. LPG Package 3-Pin TO-92 Top View

**Table 5-1. Pin Functions**

NAME	PIN		TYPE	DESCRIPTION
	DBZ	LPG		
GND	3	2	Ground	Ground pin
OUT	2	3	Output	Hall sensor open-drain output. The open drain requires a resistor pullup.
V <sub>CC</sub>	1	1	Power	2.7 V to 38 V power supply. Bypass this pin to the GND pin with a 0.01-μF (minimum) ceramic capacitor rated for V <sub>CC</sub> .

## 6 Specifications

### 6.1 Absolute Maximum Ratings

over operating free-air temperature range (unless otherwise noted) <sup>(1)</sup>

		MIN	MAX	UNIT
Power supply voltage	V <sub>CC</sub>	-22 <sup>(2)</sup>	40	V
	Voltage ramp rate (V <sub>CC</sub> ), V <sub>CC</sub> < 5 V	Unlimited		V/μs
	Voltage ramp rate (V <sub>CC</sub> ), V <sub>CC</sub> > 5 V	0	2	
Output pin voltage		-0.5	40	V
Output pin reverse current during reverse supply condition		0	100	mA
Magnetic flux density, B <sub>MAX</sub>		Unlimited		
Operating junction temperature, T <sub>J</sub>	Q, see <a href="#">Figure 9-1</a>	-40	150	°C
	E, see <a href="#">Figure 9-1</a>	-40	175	
Storage temperature, T <sub>stg</sub>		-65	150	°C

- (1) Operation outside the *Absolute Maximum Ratings* may cause permanent device damage. *Absolute Maximum Ratings* do not imply functional operation of the device at these or any other conditions beyond those listed under *Recommended Operating Conditions*. If used outside the *Recommended Operating Conditions* but within the *Absolute Maximum Ratings*, the device may not be fully functional, and this may affect device reliability, functionality, performance, and shorten the device lifetime.
- (2) Specified by design. Only tested to -20 V.

### 6.2 ESD Ratings

			VALUE	UNIT
V <sub>(ESD)</sub>	Electrostatic discharge	Human-body model (HBM), per AEC Q100-002 <sup>(1)</sup> HBM ESD classification level 2	±2500	V
		Charged-device model (CDM), per AEC Q100-011 Device HBM ESD classification level C4B	±500	

- (1) AEC Q100-002 indicates that HBM stressing shall be in accordance with the ANSI/ESDA/JEDEC JS-001 specification.

### 6.3 Recommended Operating Conditions

over operating free-air temperature range (unless otherwise noted)

		MIN	MAX	UNIT	
V <sub>CC</sub>	Power supply voltage	2.7	38	V	
V <sub>O</sub>	Output pin voltage (OUT)	0	38	V	
I <sub>SINK</sub>	Output pin current sink (OUT) <sup>(1)</sup>	0	30	mA	
T <sub>A</sub>	Operating ambient temperature	Q, see <a href="#">Figure 9-1</a>	-40	125	°C
		E, see <a href="#">Figure 9-1</a>	-40	150	

- (1) Power dissipation and thermal limits must be observed.

### 6.4 Thermal Information

THERMAL METRIC <sup>(1)</sup>		DRV5013-Q1		UNIT
		DBZ (SOT-23)	LPG (TO-92)	
		3 PINS	3 PINS	
R <sub>θJA</sub>	Junction-to-ambient thermal resistance	333.2	180	°C/W
R <sub>θJC(top)</sub>	Junction-to-case (top) thermal resistance	99.9	98.6	°C/W
R <sub>θJB</sub>	Junction-to-board thermal resistance	66.9	154.9	°C/W
ψ <sub>JT</sub>	Junction-to-top characterization parameter	4.9	40	°C/W
ψ <sub>JB</sub>	Junction-to-board characterization parameter	65.2	154.9	°C/W

- (1) For more information about traditional and new thermal metrics, see the [Semiconductor and IC Package Thermal Metrics application report](#).

## 6.5 Electrical Characteristics

over operating free-air temperature range (unless otherwise noted)

PARAMETER		TEST CONDITIONS	MIN	TYP	MAX	UNIT
<b>POWER SUPPLIES (V<sub>CC</sub>)</b>						
V <sub>CC</sub>	V <sub>CC</sub> operating voltage		2.7		38	V
I <sub>CC</sub>	Operating supply current	V <sub>CC</sub> = 2.7 V to 38 V, T <sub>A</sub> = 25°C		2.7		mA
		V <sub>CC</sub> = 2.7 V to 38 V, T <sub>A</sub> = T <sub>A, MAX</sub> <sup>(1)</sup>		3	3.5	
t <sub>on</sub>	Power-on time	AD, AG, BC versions		35	50	μs
		FA version		35	70	
<b>OPEN-DRAIN OUTPUT (OUT)</b>						
r <sub>DS(on)</sub>	FET on-resistance	V <sub>CC</sub> = 3.3 V, I <sub>O</sub> = 10 mA, T <sub>A</sub> = 25°C		22		Ω
		V <sub>CC</sub> = 3.3 V, I <sub>O</sub> = 10 mA, T <sub>A</sub> = 125 <sup>(1)</sup>		36	50	
I <sub>lkg(off)</sub>	Off-state leakage current	Output Hi-Z			1	μA
<b>PROTECTION CIRCUITS</b>						
V <sub>CCR</sub>	Reverse supply voltage		-22			V
I <sub>OCP</sub>	Overcurrent protection level	OUT shorted V <sub>CC</sub>	15	30	45	mA

(1) T<sub>A, MAX</sub> is 125°C for Q Grade 1 devices and 150°C for E Grade 0 devices (see [Figure 9-1](#)).

## 6.6 Switching Characteristics

over operating free-air temperature range (unless otherwise noted)

PARAMETER		TEST CONDITIONS	MIN	TYP	MAX	UNIT
<b>OPEN-DRAIN OUTPUT (OUT)</b>						
t <sub>d</sub>	Output delay time	B = B <sub>RP</sub> – 10 mT to B <sub>OP</sub> + 10 mT in 1 μs		13	25	μs
t <sub>r</sub>	Output rise time (10% to 90%)	R1 = 1 kΩ, C <sub>O</sub> = 50 pF, V <sub>CC</sub> = 3.3 V		200		ns
t <sub>f</sub>	Output fall time (90% to 10%)	R1 = 1 kΩ, C <sub>O</sub> = 50 pF, V <sub>CC</sub> = 3.3 V		31		ns

## 6.7 Magnetic Characteristics

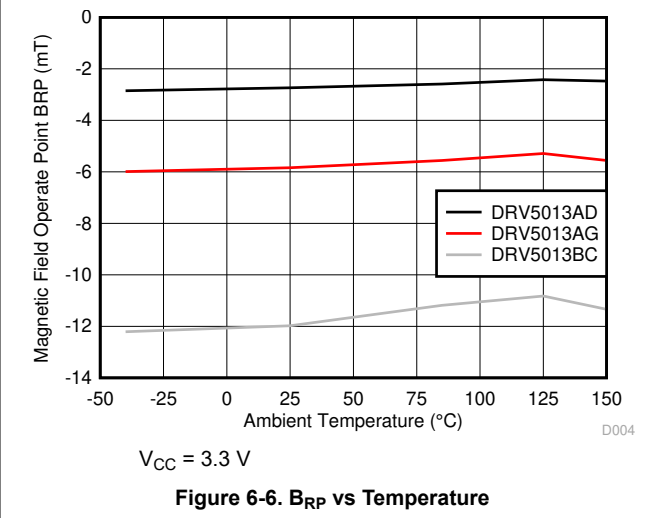
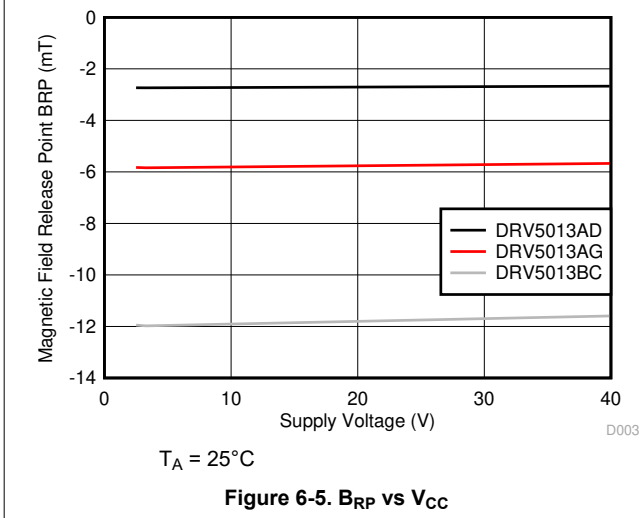
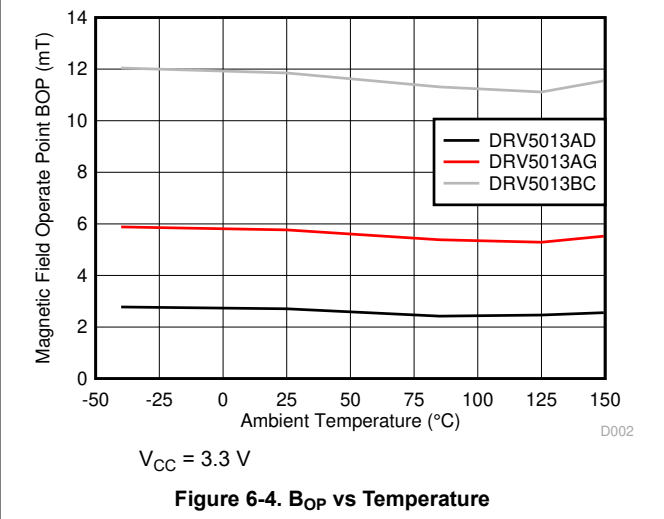
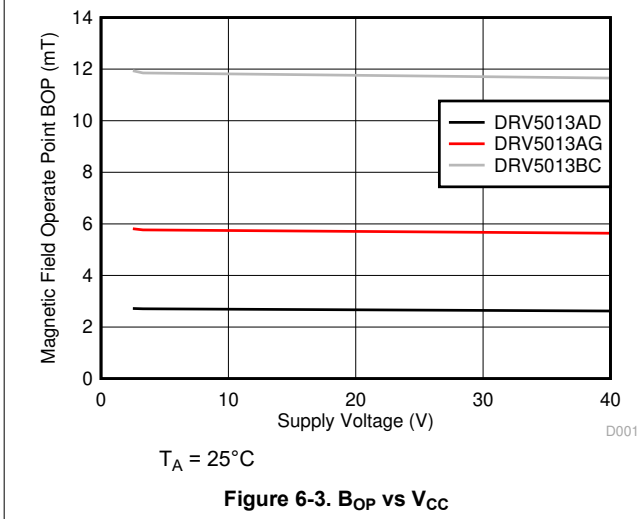
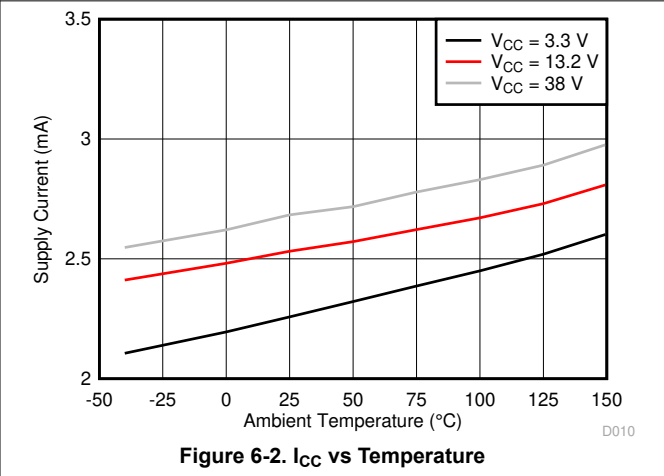
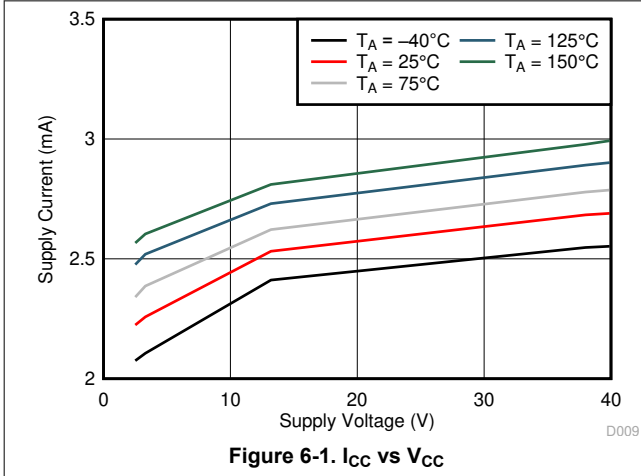
over operating free-air temperature range (unless otherwise noted)

PARAMETER		TEST CONDITIONS	MIN	TYP	MAX	UNIT <sup>(1)</sup>
$f_{BW}$	Bandwidth <sup>(2)</sup>		20	30		kHz
DRV5013FA: ±1.3 mT						
$B_{OP}$	Operate point; see <a href="#">Figure 7-2</a>		-0.6	1.3	3.4	mT
$B_{RP}$	Release point; see <a href="#">Figure 7-2</a>		-3.4	-1.3	0.6	mT
$B_{hys}$	Hysteresis; $B_{hys} = (B_{OP} - B_{RP})$		1.2	2.6		mT
$B_O$	Magnetic offset; $B_O = (B_{OP} + B_{RP}) / 2$		-1.5	0	1.5	mT
DRV5013AD: ±2.7 mT						
$B_{OP}$	Operate point; see <a href="#">Figure 7-2</a>		1	2.7	5	mT
$B_{RP}$	Release point; see <a href="#">Figure 7-2</a>		-5	-2.7	-1	mT
$B_{hys}$	Hysteresis; $B_{hys} = (B_{OP} - B_{RP})$			5.4		mT
$B_O$	Magnetic offset; $B_O = (B_{OP} + B_{RP}) / 2$		-1.5	0	1.5	mT
DRV5013AG: ±6 mT						
$B_{OP}$	Operate point; see <a href="#">Figure 7-2</a>		3	6	9	mT
$B_{RP}$	Release point; see <a href="#">Figure 7-2</a>		-9	-6	-3	mT
$B_{hys}$	Hysteresis; $B_{hys} = (B_{OP} - B_{RP})$			12		mT
$B_O$	Magnetic offset; $B_O = (B_{OP} + B_{RP}) / 2$		-1.5	0	1.5	mT
DRV5013BC: ±12 mT						
$B_{OP}$	Operate point; see <a href="#">Figure 7-2</a>		6	12	18	mT
$B_{RP}$	Release point; see <a href="#">Figure 7-2</a>		-18	-12	-6	mT
$B_{hys}$	Hysteresis; $B_{hys} = (B_{OP} - B_{RP})$			24		mT
$B_O$	Magnetic offset; $B_O = (B_{OP} + B_{RP}) / 2$		-1.5	0	1.5	mT

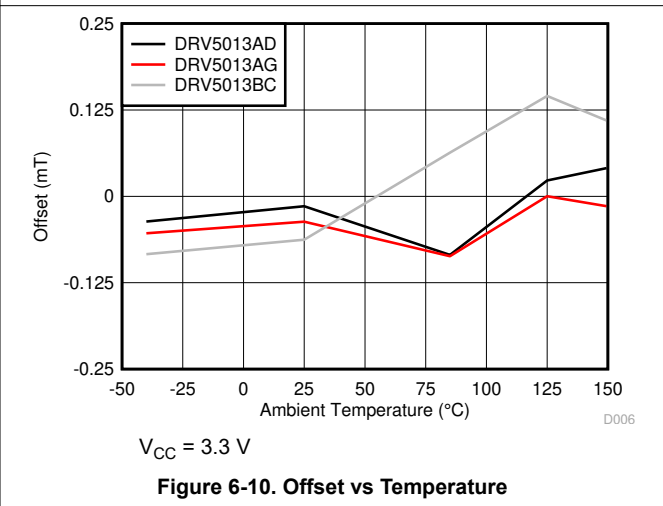
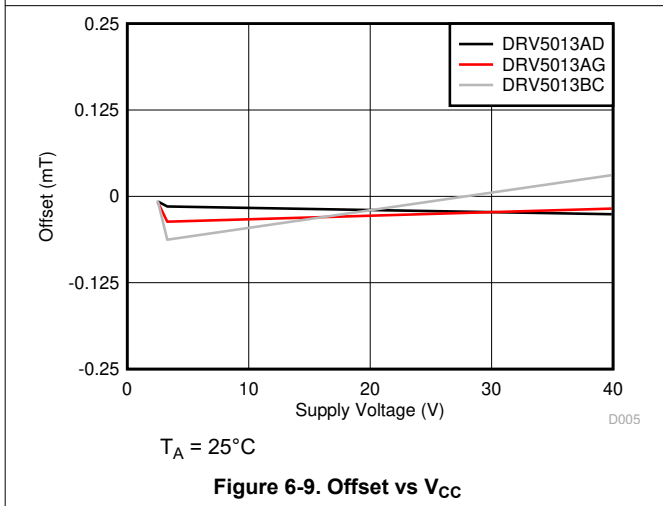
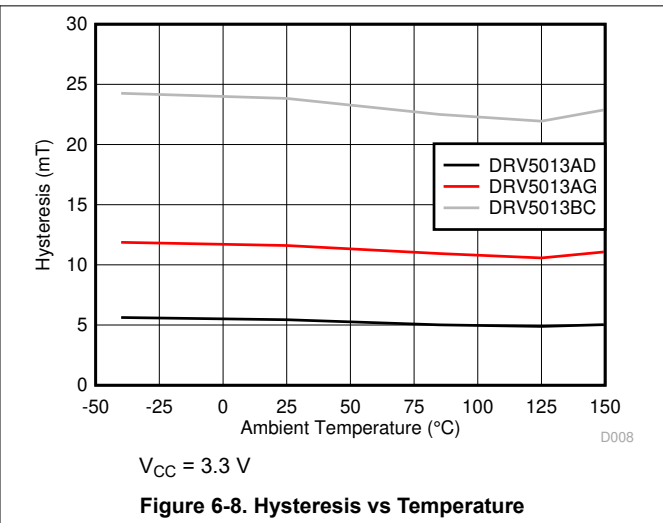
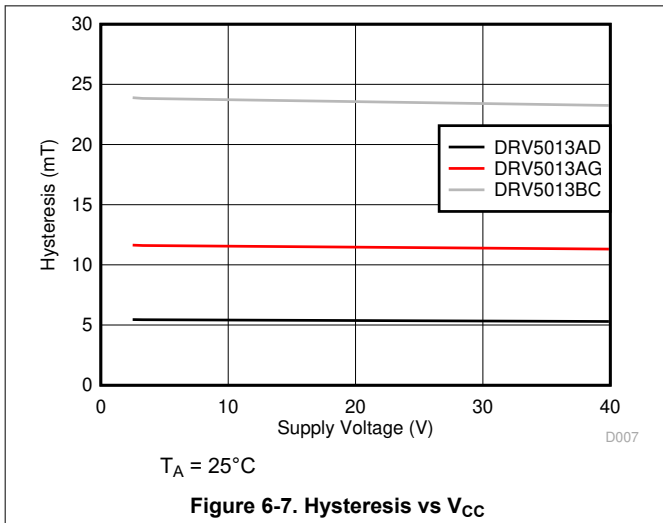
(1) 1 mT = 10 Gauss.

(2) Bandwidth describes the fastest changing magnetic field that can be detected and translated to the output.

## 6.8 Typical Characteristics



### 6.8 Typical Characteristics (continued)





## 7 Detailed Description

### 7.1 Overview

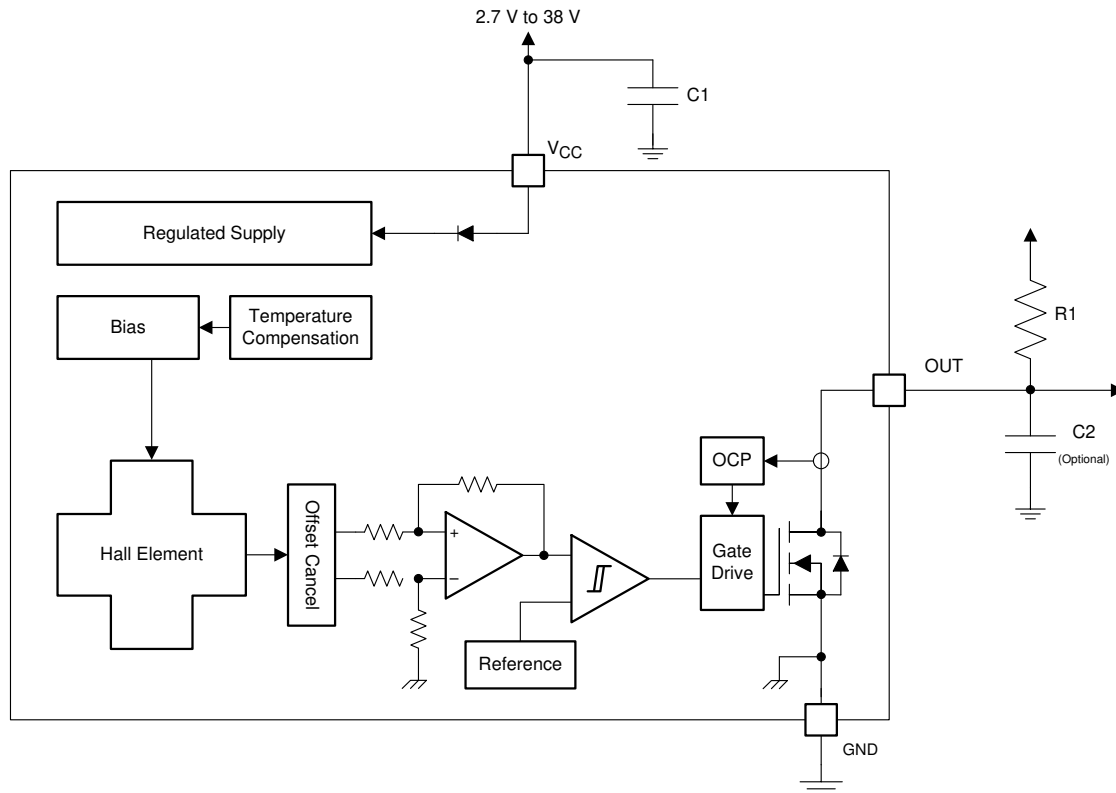
The DRV5013-Q1 device is a chopper-stabilized Hall sensor with a digital latched output for magnetic sensing applications. The DRV5013-Q1 device can be powered with a supply voltage between 2.7 V and 38 V, and continuously survives continuous  $-22$  V reverse-battery conditions. The DRV5013-Q1 device does not operate when  $-22$  V to 2.4 V is applied to the  $V_{CC}$  pin (with respect to the GND pin). In addition, the device can withstand voltages up to 40 V for transient durations.

The field polarity is defined as follows: a **south pole** near the marked side of the package is a positive magnetic field. A **north pole** near the marked side of the package is a negative magnetic field.

The output state is dependent on the magnetic field perpendicular to the package. A **south pole** near the marked side of the package causes the output to pull low (operate point,  $B_{OP}$ ), and a **north pole** near the marked side of the package causes the output to release (release point,  $B_{RP}$ ). Hysteresis is included in between the operate point and the release point therefore magnetic-field noise does not accidentally trip the output.

An external pullup resistor is required on the OUT pin. The OUT pin can be pulled up to  $V_{CC}$ , or to a different voltage supply. This allows for easier interfacing with controller circuits.

### 7.2 Functional Block Diagram

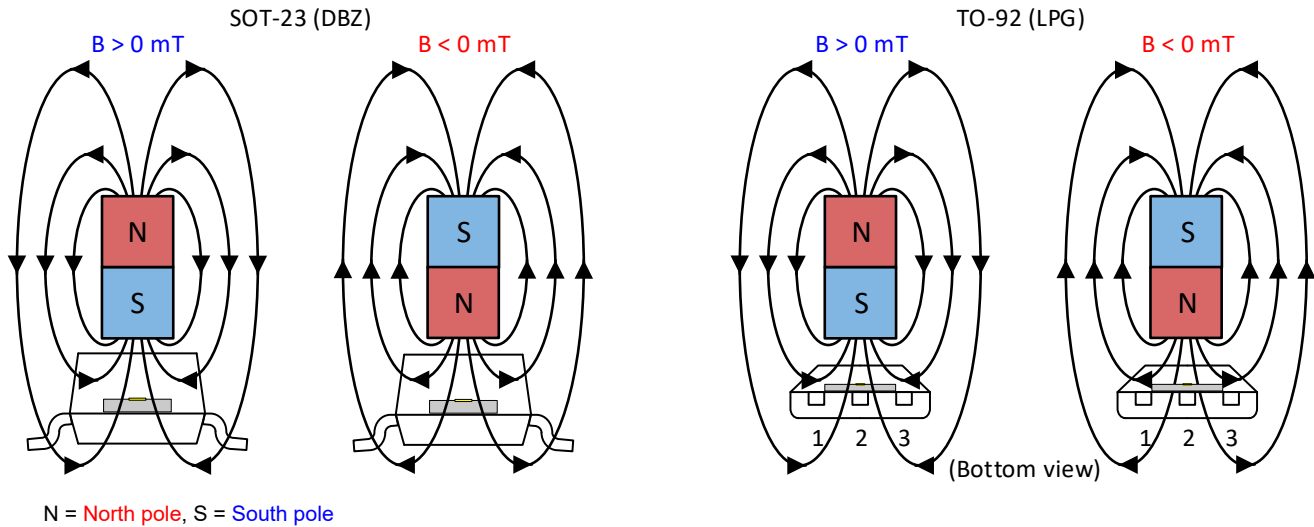


Copyright © 2017, Texas Instruments Incorporated

### 7.3 Feature Description

#### 7.3.1 Field Direction Definition

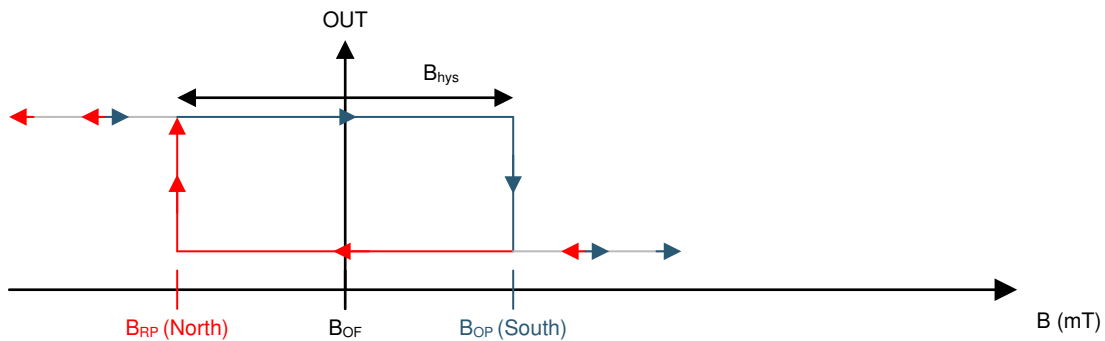
Figure 7-1 shows the positive magnetic field defined as a south pole near the marked side of the package.



**Figure 7-1. Field Direction Definition**

#### 7.3.2 Device Output

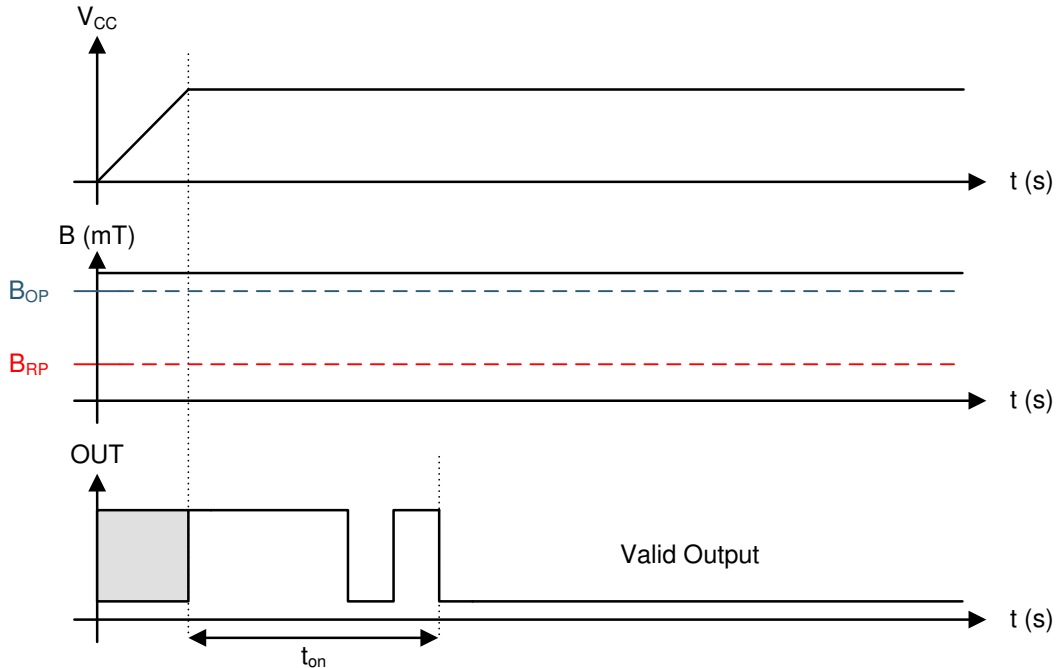
If the device is powered on with a magnetic field strength between  $B_{RP}$  and  $B_{OP}$ , then the device output is indeterminate and can either be Hi-Z or Low. If the field strength is greater than  $B_{OP}$ , then the output is pulled low. If the field strength is less than  $B_{RP}$ , then the output is released.



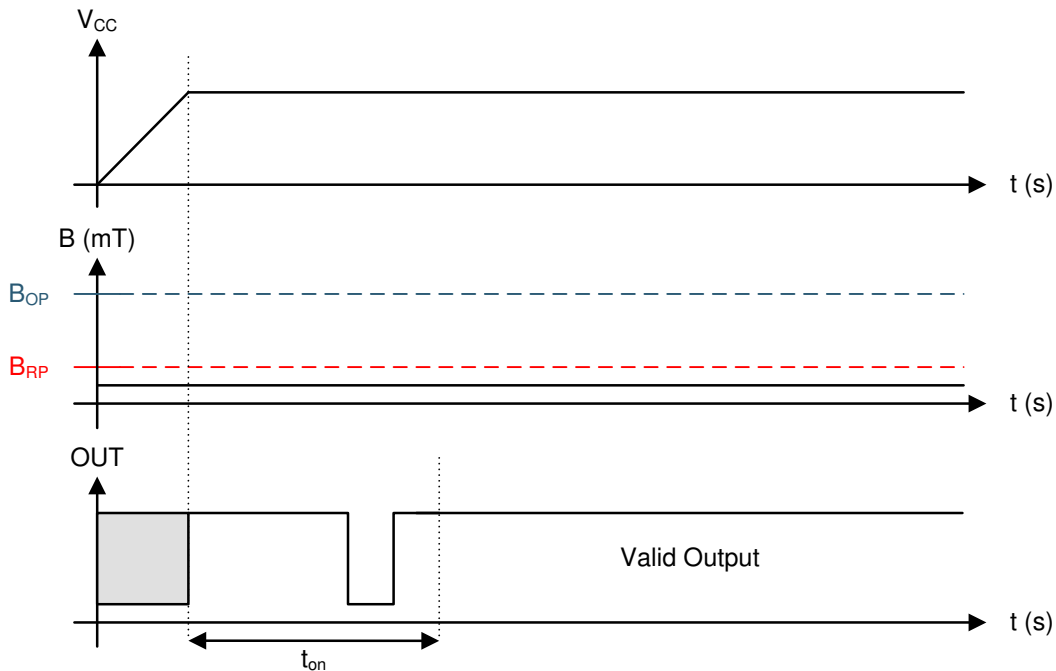
**Figure 7-2. DRV5013-Q1 —  $B_{OP} > 0$**

### 7.3.3 Power-On Time

After applying  $V_{CC}$  to the DRV5013-Q1 device,  $t_{on}$  must elapse before the OUT pin is valid. During the power-up sequence, the output is Hi-Z. A pulse as shown in Figure 7-3 and Figure 7-4 occurs at the end of  $t_{on}$ . This pulse can allow the host processor to determine when the DRV5013-Q1 output is valid after start-up. In Case 1 (Figure 7-3) and Case 2 (Figure 7-4), the output is defined assuming a constant magnetic field  $B > B_{OP}$  and  $B < B_{RP}$ .



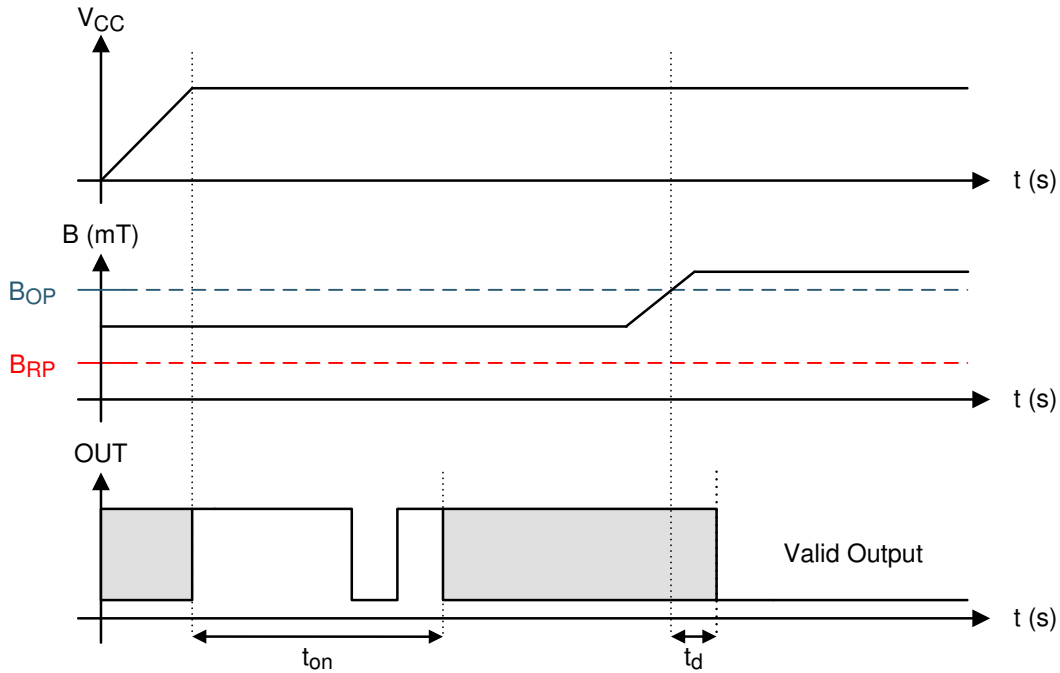
**Figure 7-3. Case 1: Power On When  $B > B_{OP}$**



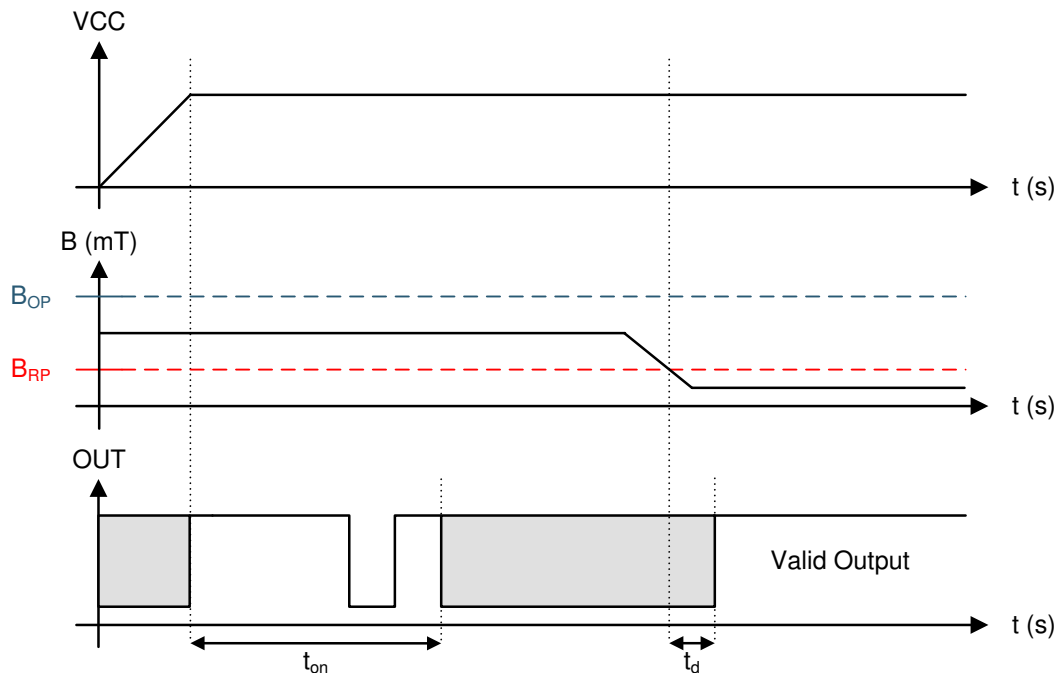
**Figure 7-4. Case 2: Power On When  $B < B_{RP}$**

If the device is powered on with the magnetic field strength  $B_{RP} < B < B_{OP}$ , then the device output is indeterminate and can either be Hi-Z or pulled low. During the power-up sequence, the output is held Hi-Z

until  $t_{on}$  has elapsed. At the end of  $t_{on}$ , a pulse is given on the OUT pin to indicate that  $t_{on}$  has elapsed. After  $t_{on}$ , if the magnetic field changes such that  $B_{OP} < B$ , the output is released. Case 3 (Figure 7-5) and Case 4 (Figure 7-6) show examples of this behavior.



**Figure 7-5. Case 3: Power On When  $B_{RP} < B < B_{OP}$ , Followed by  $B > B_{OP}$**



**Figure 7-6. Case 4: Power On When  $B_{RP} < B < B_{OP}$ , Followed by  $B < B_{RP}$**

### 7.3.4 Output Stage

Figure 7-7 shows the DRV5013-Q1 open-drain NMOS output structure, rated to sink up to 30 mA of current. For proper operation, use Equation 1 to calculate the value of pullup resistor R1.

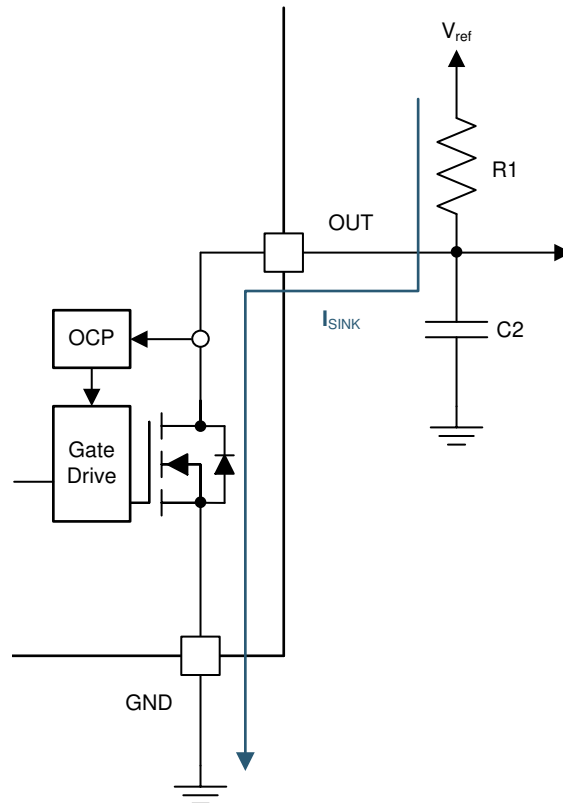
$$\frac{V_{ref\ max}}{30\ mA} \leq R1 \leq \frac{V_{ref\ min}}{100\ \mu A} \tag{1}$$

The size of R1 is a tradeoff between the OUT rise time and the current when OUT is pulled low. A lower current is generally better, however faster transitions and bandwidth require a smaller resistor for faster switching.

In addition, make sure that the value of R1 > 500 Ω so that the output driver can pull the OUT pin close to GND.

**Note**

V<sub>ref</sub> is not restricted to V<sub>CC</sub>. The allowable voltage range of this pin is specified in the [Absolute Maximum Ratings](#).



**Figure 7-7. NMOS Open-Drain Output**

Select a value for C2 based on the system bandwidth specifications as shown in [Equation 2](#).

$$2 \times f_{BW} \text{ (Hz)} < \frac{1}{2\pi \times R1 \times C2} \tag{2}$$

Most applications do not require this C2 filtering capacitor.

### 7.3.5 Protection Circuits

The DRV5013-Q1 device is fully protected against overcurrent and reverse-supply conditions. [Table 7-1](#) lists a summary of the protection circuits.

**Table 7-1. Protection Circuit Summary**

FAULT	CONDITION	DEVICE	DESCRIPTION	RECOVERY
FET overload (OCP)	$I_{\text{SINK}} \geq I_{\text{OCP}}$	Operating	Output current is clamped to $I_{\text{OCP}}$	$I_o < I_{\text{OCP}}$
Load dump	$38 \text{ V} < V_{\text{CC}} < 40 \text{ V}$	Operating	Device will operate for a transient duration	$V_{\text{CC}} \leq 38 \text{ V}$
Reverse supply	$-22 \text{ V} < V_{\text{CC}} < 0 \text{ V}$	Disabled	Device will survive this condition	$V_{\text{CC}} \geq 2.7 \text{ V}$

#### 7.3.5.1 Overcurrent Protection (OCP)

An analog current-limit circuit limits the current through the FET. The driver current is clamped to  $I_{\text{OCP}}$ . During this clamping, the  $r_{\text{DS(on)}}$  of the output FET is increased from the nominal value.

#### 7.3.5.2 Load Dump Protection

The DRV5013-Q1 device operates at DC  $V_{\text{CC}}$  conditions up to 38 V nominally, and can additionally withstand  $V_{\text{CC}} = 40 \text{ V}$ . No current-limiting series resistor is required for this protection.

#### 7.3.5.3 Reverse Supply Protection

The DRV5013-Q1 device is protected in the event that the  $V_{\text{CC}}$  pin and the GND pin are reversed (up to  $-22 \text{ V}$ ).

#### Note

In a reverse supply condition, the OUT pin reverse-current must not exceed the ratings specified in the [Absolute Maximum Ratings](#).

## 7.4 Device Functional Modes

The DRV5013-Q1 device is active only when  $V_{\text{CC}}$  is between 2.7 V and 38 V.

When a reverse supply condition exists, the device is inactive. With regard to some industry standards that require analyzing every possible output from a device, an internal clock is unlikely to couple to the output.

## 8 Application and Implementation

### Note

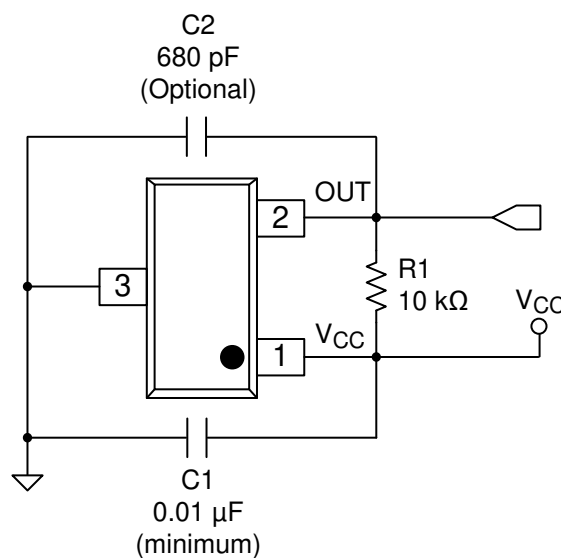
Information in the following applications sections is not part of the TI component specification, and TI does not warrant its accuracy or completeness. TI's customers are responsible for determining suitability of components for their purposes, as well as validating and testing their design implementation to confirm system functionality.

### 8.1 Application Information

The DRV5013-Q1 device is used in magnetic-field sensing applications.

### 8.2 Typical Applications

#### 8.2.1 Standard Circuit



**Figure 8-1. Typical Application Circuit**

#### 8.2.1.1 Design Requirements

For this design example, use the parameters listed in [Table 8-1](#) as the input parameters.

**Table 8-1. Design Parameters**

DESIGN PARAMETER	REFERENCE	EXAMPLE VALUE
Supply voltage	$V_{CC}$	3.2 to 3.4 V
System bandwidth	$f_{BW}$	10 kHz

#### 8.2.1.2 Detailed Design Procedure

**Table 8-2. External Components**

COMPONENT	PIN 1	PIN 2	RECOMMENDED
C1	$V_{CC}$	GND	A 0.01- $\mu$ F (minimum) ceramic capacitor rated for $V_{CC}$
C2	OUT	GND	<b>Optional:</b> Place a ceramic capacitor to GND
R1	OUT	REF <sup>(1)</sup>	Requires a resistor pullup

(1) REF is not a pin on the DRV5013-Q1 device, but a REF supply-voltage pullup is required for the OUT pin; the OUT pin may be pulled up to  $V_{CC}$ .

### 8.2.1.2.1 Configuration Example

In a 3.3-V system,  $3.2 \text{ V} \leq V_{\text{ref}} \leq 3.4 \text{ V}$ . Use Equation 3 to calculate the allowable range for R1.

$$\frac{V_{\text{ref max}}}{30 \text{ mA}} \leq R1 \leq \frac{V_{\text{ref min}}}{100 \mu\text{A}} \quad (3)$$

For this design example, use Equation 4 to calculate the allowable range of R1.

$$\frac{3.4 \text{ V}}{30 \text{ mA}} \leq R1 \leq \frac{3.2 \text{ V}}{100 \mu\text{A}} \quad (4)$$

Therefore:

$$113 \Omega \leq R1 \leq 32 \text{ k}\Omega \quad (5)$$

After finding the allowable range of R1 (Equation 5), select a value between 500  $\Omega$  and 32 k $\Omega$  for R1.

Assuming a system bandwidth of 10 kHz, use Equation 6 to calculate the value of C2.

$$2 \times f_{\text{BW}} \text{ (Hz)} < \frac{1}{2\pi \times R1 \times C2} \quad (6)$$

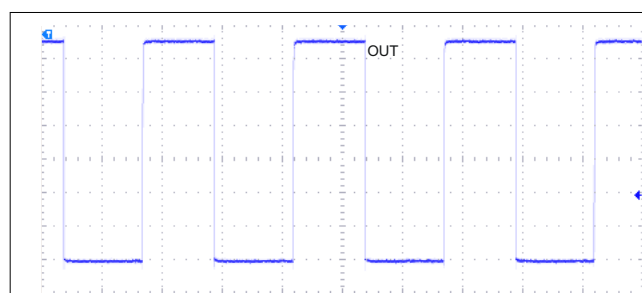
For this design example, use Equation 7 to calculate the value of C2.

$$2 \times 10 \text{ kHz} < \frac{1}{2\pi \times R1 \times C2} \quad (7)$$

An R1 value of 10 k $\Omega$  and a C2 value less than 820 pF satisfy the requirement for a 10-kHz system bandwidth.

A selection of R1 = 10 k $\Omega$  and C2 = 680 pF would cause a low-pass filter with a corner frequency of 23.4 kHz.

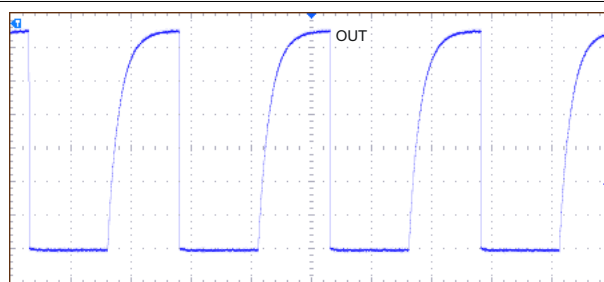
### 8.2.1.3 Application Curves



R1 = 10 k $\Omega$  pull-up

No C2

**Figure 8-2. 10-kHz Switching Magnetic Field**

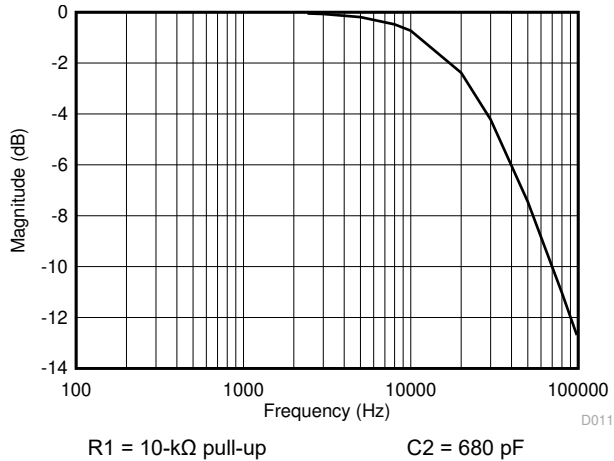


R1 = 10-k $\Omega$  pull-up

C2 = 680 pF

**Figure 8-3. 10-kHz Switching Magnetic Field**

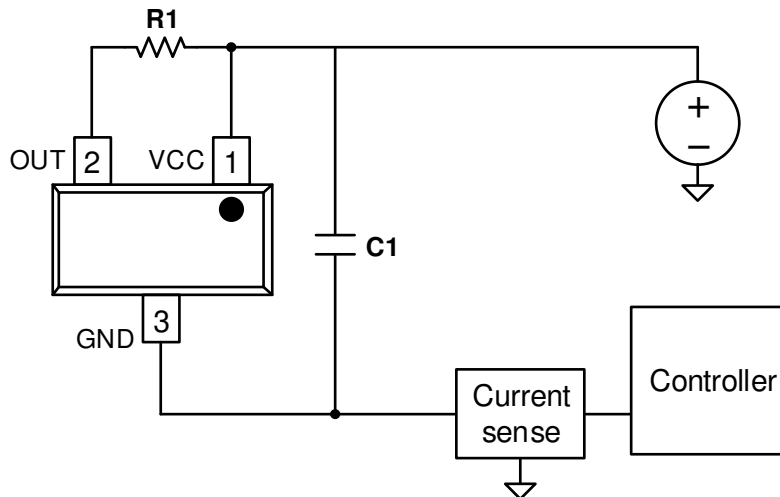




**Figure 8-4. Low-Pass Filtering**

### 8.2.2 Alternative Two-Wire Application

For systems that require minimal wire count, the device output can be connected to  $V_{CC}$  through a resistor, and the total supplied current can be sensed near the controller.



**Figure 8-5. 2-Wire Application**

Current can be sensed using a shunt resistor or other circuitry.

#### 8.2.2.1 Design Requirements

Table 8-3 lists the related design parameters.

**Table 8-3. Design Parameters**

DESIGN PARAMETER	REFERENCE	EXAMPLE VALUE
Supply voltage	$V_{CC}$	12 V
OUT resistor	R1	1 kΩ
Bypass capacitor	C1	0.1 μF
Current when $B < B_{RP}$	$I_{RELEASE}$	About 3 mA
Current when $B > B_{OP}$	$I_{OPERATE}$	About 15 mA

### 8.2.2.2 Detailed Design Procedure

When the open-drain output of the device is high-impedance, current through the path equals the  $I_{CC}$  of the device (approximately 3 mA).

When the output pulls low, a parallel current path is added, equal to  $V_{CC} / (R1 + r_{DS(on)})$ . Using 12 V and 1 k $\Omega$ , the parallel current is approximately 12 mA, making the total current approximately 15 mA.

The local bypass capacitor C1 should be at least 0.1  $\mu$ F, and a larger value if there is high inductance in the power line interconnect.

## 8.3 Power Supply Recommendations

The DRV5013-Q1 device is designed to operate from an input voltage supply ( $V_M$ ) range between 2.7 V and 38 V. A 0.01- $\mu$ F (minimum) ceramic capacitor rated for  $V_{CC}$  must be placed as close to the DRV5013-Q1 device as possible. Larger values of the bypass capacitor may be needed to attenuate any significant high-frequency ripple and noise components generated by the power source. TI recommends limiting the supply voltage variation to less than 50 mV $_{PP}$ .

## 8.4 Layout

### 8.4.1 Layout Guidelines

The bypass capacitor should be placed near the DRV5013-Q1 device for efficient power delivery with minimal inductance. The external pullup resistor should be placed near the microcontroller input to provide the most stable voltage at the input; alternatively, an integrated pullup resistor within the GPIO of the microcontroller can be used.

Generally, using PCB copper planes underneath the DRV5013-Q1 device has no effect on magnetic flux, and does not interfere with device performance. This is because copper is not a ferromagnetic material. However, if nearby system components contain iron or nickel, they may redirect magnetic flux in unpredictable ways.

### 8.4.2 Layout Example

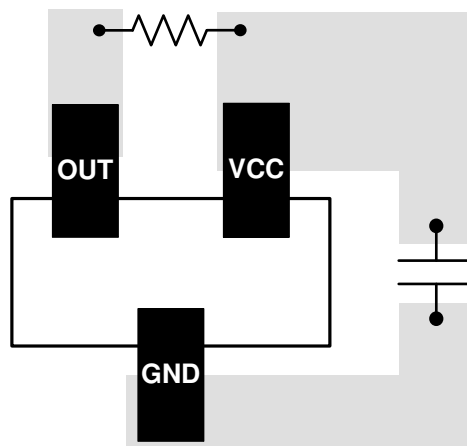


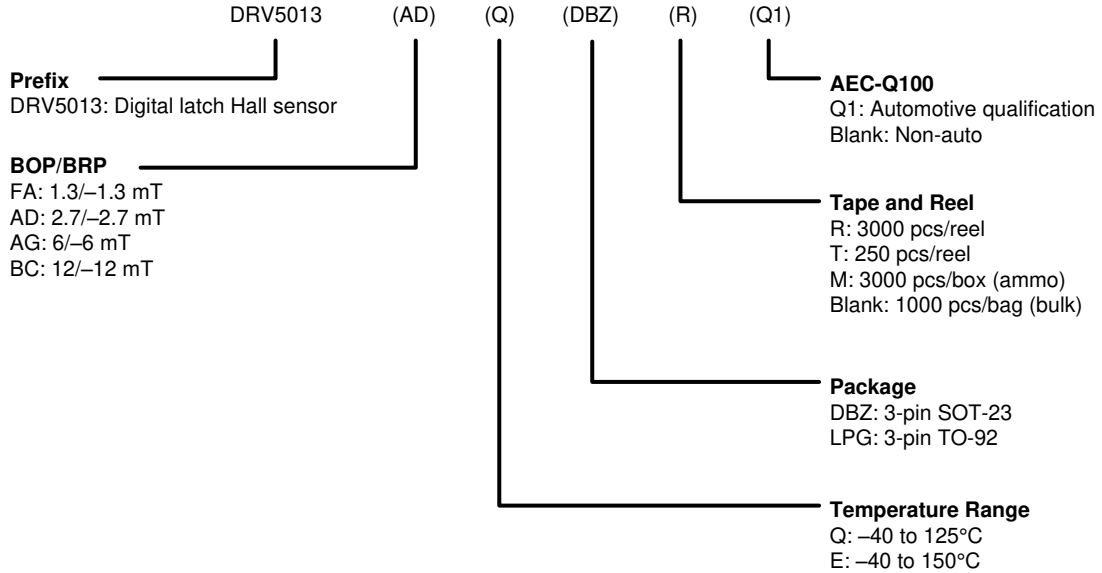
Figure 8-6. DRV5013-Q1 Layout Example

## 9 Device and Documentation Support

### 9.1 Device Support

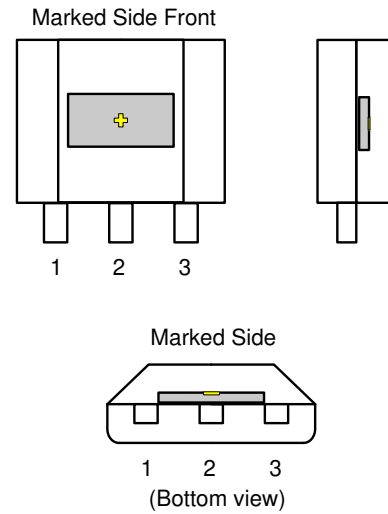
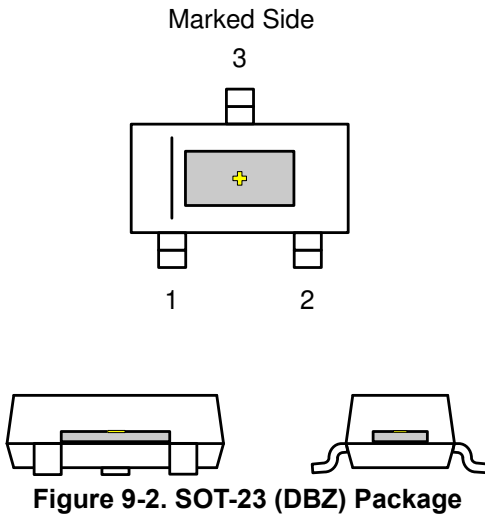
#### 9.1.1 Device Nomenclature

Figure 9-1 shows a legend for reading the complete device name for and DRV5013-Q1 device.



**Figure 9-1. Device Nomenclature**

#### 9.1.2 Device Markings



## 9.2 Receiving Notification of Documentation Updates

To receive notification of documentation updates, navigate to the device product folder on [ti.com](http://ti.com). Click on *Subscribe to updates* to register and receive a weekly digest of any product information that has changed. For change details, review the revision history included in any revised document.

## 9.3 Support Resources

[TI E2E™ support forums](#) are an engineer's go-to source for fast, verified answers and design help — straight from the experts. Search existing answers or ask your own question to get the quick design help you need.

Linked content is provided "AS IS" by the respective contributors. They do not constitute TI specifications and do not necessarily reflect TI's views; see TI's [Terms of Use](#).

## 9.4 Trademarks

TI E2E™ is a trademark of Texas Instruments.

All trademarks are the property of their respective owners.

## 9.5 Electrostatic Discharge Caution



This integrated circuit can be damaged by ESD. Texas Instruments recommends that all integrated circuits be handled with appropriate precautions. Failure to observe proper handling and installation procedures can cause damage.

ESD damage can range from subtle performance degradation to complete device failure. Precision integrated circuits may be more susceptible to damage because very small parametric changes could cause the device not to meet its published specifications.

## 9.6 Glossary

[TI Glossary](#) This glossary lists and explains terms, acronyms, and definitions.

## 10 Mechanical, Packaging, and Orderable Information

The following pages include mechanical, packaging, and orderable information. This information is the most current data available for the designated devices. This data is subject to change without notice and revision of this document. For browser-based versions of this data sheet, refer to the left-hand navigation.

**PACKAGING INFORMATION**

Orderable Device	Status (1)	Package Type	Package Drawing	Pins	Package Qty	Eco Plan (2)	Lead finish/ Ball material (6)	MSL Peak Temp (3)	Op Temp (°C)	Device Marking (4/5)	Samples
DRV5013ADEDDBZJQ1	ACTIVE	SOT-23	DBZ	3	10000	RoHS & Green	NIPDAUAG	Level-1-260C-UNLIM	-40 to 150	+NJAD	<a href="#">Samples</a>
DRV5013ADEDDBZRQ1	ACTIVE	SOT-23	DBZ	3	3000	RoHS & Green	NIPDAUAG   SN	Level-1-260C-UNLIM	-40 to 150	+NJAD	<a href="#">Samples</a>
DRV5013ADELPGMQ1	ACTIVE	TO-92	LPG	3	3000	RoHS & Green	SN	N / A for Pkg Type	-40 to 150	+NJAD	<a href="#">Samples</a>
DRV5013ADELPGQ1	ACTIVE	TO-92	LPG	3	1000	RoHS & Green	SN	N / A for Pkg Type	-40 to 150	+NJAD	<a href="#">Samples</a>
DRV5013ADQDBZRQ1	ACTIVE	SOT-23	DBZ	3	3000	RoHS & Green	NIPDAUAG   SN	Level-1-260C-UNLIM	-40 to 125	+NKAD	<a href="#">Samples</a>
DRV5013ADQLPGMQ1	ACTIVE	TO-92	LPG	3	3000	RoHS & Green	SN	N / A for Pkg Type	-40 to 125	+NKAD	<a href="#">Samples</a>
DRV5013ADQLPGQ1	ACTIVE	TO-92	LPG	3	1000	RoHS & Green	SN	N / A for Pkg Type	-40 to 125	+NKAD	<a href="#">Samples</a>
DRV5013AGEDBZRQ1	ACTIVE	SOT-23	DBZ	3	3000	RoHS & Green	NIPDAUAG	Level-1-260C-UNLIM	-40 to 150	+NJAG	<a href="#">Samples</a>
DRV5013AGELPGMQ1	ACTIVE	TO-92	LPG	3	3000	RoHS & Green	SN	N / A for Pkg Type	-40 to 150	+NJAG	<a href="#">Samples</a>
DRV5013AGELPGQ1	ACTIVE	TO-92	LPG	3	1000	RoHS & Green	SN	N / A for Pkg Type	-40 to 150	+NJAG	<a href="#">Samples</a>
DRV5013AGQDBZRQ1	ACTIVE	SOT-23	DBZ	3	3000	RoHS & Green	NIPDAUAG	Level-1-260C-UNLIM	-40 to 125	+NKAG	<a href="#">Samples</a>
DRV5013AGQLPGMQ1	ACTIVE	TO-92	LPG	3	3000	RoHS & Green	SN	N / A for Pkg Type	-40 to 125	+NKAG	<a href="#">Samples</a>
DRV5013AGQLPGQ1	ACTIVE	TO-92	LPG	3	1000	RoHS & Green	SN	N / A for Pkg Type	-40 to 125	+NKAG	<a href="#">Samples</a>
DRV5013BCEDBZRQ1	ACTIVE	SOT-23	DBZ	3	3000	RoHS & Green	NIPDAUAG	Level-1-260C-UNLIM	-40 to 150	+NJBC	<a href="#">Samples</a>
DRV5013BCELPGMQ1	ACTIVE	TO-92	LPG	3	3000	RoHS & Green	SN	N / A for Pkg Type	-40 to 150	+NJBC	<a href="#">Samples</a>
DRV5013BCELPGQ1	ACTIVE	TO-92	LPG	3	1000	RoHS & Green	SN	N / A for Pkg Type	-40 to 150	+NJBC	<a href="#">Samples</a>
DRV5013BCQDBZRQ1	ACTIVE	SOT-23	DBZ	3	3000	RoHS & Green	NIPDAUAG	Level-1-260C-UNLIM	-40 to 125	+NKBC	<a href="#">Samples</a>
DRV5013BCQLPGMQ1	ACTIVE	TO-92	LPG	3	3000	RoHS & Green	SN	N / A for Pkg Type	-40 to 125	+NKBC	<a href="#">Samples</a>
DRV5013BCQLPGQ1	ACTIVE	TO-92	LPG	3	1000	RoHS & Green	SN	N / A for Pkg Type	-40 to 125	+NKBC	<a href="#">Samples</a>
DRV5013FAEDBZRQ1	ACTIVE	SOT-23	DBZ	3	3000	RoHS & Green	SN	Level-1-260C-UNLIM	-40 to 150	+NJFA	<a href="#">Samples</a>

(1) The marketing status values are defined as follows:

**ACTIVE:** Product device recommended for new designs.

**LIFEBUY:** TI has announced that the device will be discontinued, and a lifetime-buy period is in effect.

**NRND:** Not recommended for new designs. Device is in production to support existing customers, but TI does not recommend using this part in a new design.

**PREVIEW:** Device has been announced but is not in production. Samples may or may not be available.

**OBSOLETE:** TI has discontinued the production of the device.

(2) **RoHS:** TI defines "RoHS" to mean semiconductor products that are compliant with the current EU RoHS requirements for all 10 RoHS substances, including the requirement that RoHS substance do not exceed 0.1% by weight in homogeneous materials. Where designed to be soldered at high temperatures, "RoHS" products are suitable for use in specified lead-free processes. TI may reference these types of products as "Pb-Free".

**RoHS Exempt:** TI defines "RoHS Exempt" to mean products that contain lead but are compliant with EU RoHS pursuant to a specific EU RoHS exemption.

**Green:** TI defines "Green" to mean the content of Chlorine (Cl) and Bromine (Br) based flame retardants meet JS709B low halogen requirements of  $\leq 1000$ ppm threshold. Antimony trioxide based flame retardants must also meet the  $\leq 1000$ ppm threshold requirement.

(3) **MSL, Peak Temp.** - The Moisture Sensitivity Level rating according to the JEDEC industry standard classifications, and peak solder temperature.

(4) There may be additional marking, which relates to the logo, the lot trace code information, or the environmental category on the device.

(5) Multiple Device Markings will be inside parentheses. Only one Device Marking contained in parentheses and separated by a "~" will appear on a device. If a line is indented then it is a continuation of the previous line and the two combined represent the entire Device Marking for that device.

(6) **Lead finish/Ball material** - Orderable Devices may have multiple material finish options. Finish options are separated by a vertical ruled line. Lead finish/Ball material values may wrap to two lines if the finish value exceeds the maximum column width.

**Important Information and Disclaimer:**The information provided on this page represents TI's knowledge and belief as of the date that it is provided. TI bases its knowledge and belief on information provided by third parties, and makes no representation or warranty as to the accuracy of such information. Efforts are underway to better integrate information from third parties. TI has taken and continues to take reasonable steps to provide representative and accurate information but may not have conducted destructive testing or chemical analysis on incoming materials and chemicals. TI and TI suppliers consider certain information to be proprietary, and thus CAS numbers and other limited information may not be available for release.

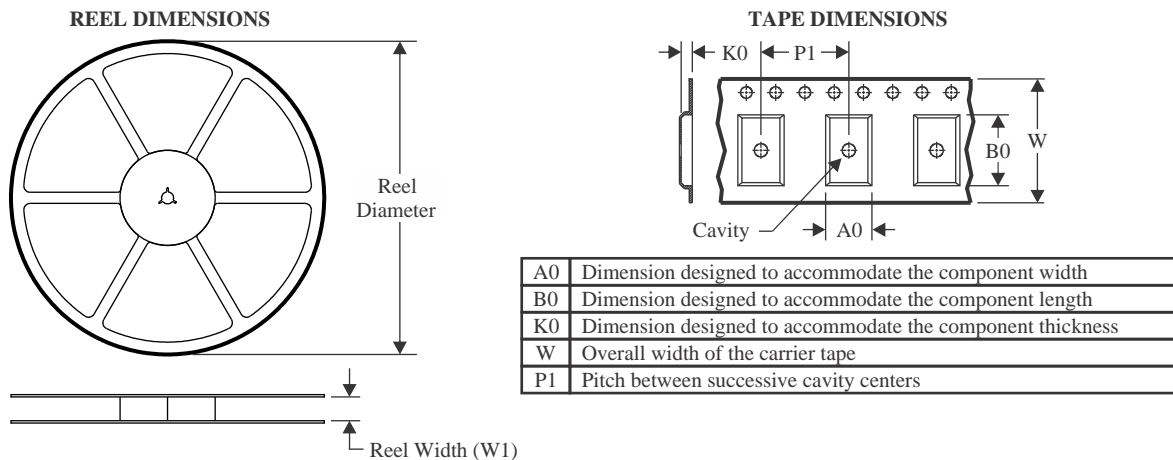
In no event shall TI's liability arising out of such information exceed the total purchase price of the TI part(s) at issue in this document sold by TI to Customer on an annual basis.

#### **OTHER QUALIFIED VERSIONS OF DRV5013-Q1 :**

- Catalog : [DRV5013](#)

NOTE: Qualified Version Definitions:

- Catalog - TI's standard catalog product

**TAPE AND REEL INFORMATION**

**QUADRANT ASSIGNMENTS FOR PIN 1 ORIENTATION IN TAPE**


\*All dimensions are nominal

Device	Package Type	Package Drawing	Pins	SPQ	Reel Diameter (mm)	Reel Width W1 (mm)	A0 (mm)	B0 (mm)	K0 (mm)	P1 (mm)	W (mm)	Pin1 Quadrant
DRV5013AEDBZJQ1	SOT-23	DBZ	3	10000	330.0	8.4	3.15	2.77	1.22	4.0	8.0	Q3
DRV5013AEDBZRQ1	SOT-23	DBZ	3	3000	180.0	8.4	3.15	2.77	1.22	4.0	8.0	Q3
DRV5013ADQDBZRQ1	SOT-23	DBZ	3	3000	180.0	8.4	3.15	2.77	1.22	4.0	8.0	Q3
DRV5013AGEDBZRQ1	SOT-23	DBZ	3	3000	180.0	8.4	3.15	2.77	1.22	4.0	8.0	Q3
DRV5013AGQDBZRQ1	SOT-23	DBZ	3	3000	180.0	8.4	3.15	2.77	1.22	4.0	8.0	Q3
DRV5013BCEDBZRQ1	SOT-23	DBZ	3	3000	180.0	8.4	3.15	2.77	1.22	4.0	8.0	Q3
DRV5013BCQDBZRQ1	SOT-23	DBZ	3	3000	180.0	8.4	3.15	2.77	1.22	4.0	8.0	Q3
DRV5013FAEDBZRQ1	SOT-23	DBZ	3	3000	180.0	8.4	3.15	2.77	1.22	4.0	8.0	Q3

## TAPE AND REEL BOX DIMENSIONS



\*All dimensions are nominal

Device	Package Type	Package Drawing	Pins	SPQ	Length (mm)	Width (mm)	Height (mm)
DRV5013ADEDZJQ1	SOT-23	DBZ	3	10000	346.0	346.0	29.0
DRV5013ADEDZBZRQ1	SOT-23	DBZ	3	3000	202.0	201.0	28.0
DRV5013ADQDBZRQ1	SOT-23	DBZ	3	3000	202.0	201.0	28.0
DRV5013AGEDBZRQ1	SOT-23	DBZ	3	3000	202.0	201.0	28.0
DRV5013AGQDBZRQ1	SOT-23	DBZ	3	3000	202.0	201.0	28.0
DRV5013BCEDBZRQ1	SOT-23	DBZ	3	3000	202.0	201.0	28.0
DRV5013BCQDBZRQ1	SOT-23	DBZ	3	3000	202.0	201.0	28.0
DRV5013FAEDBZRQ1	SOT-23	DBZ	3	3000	202.0	201.0	28.0



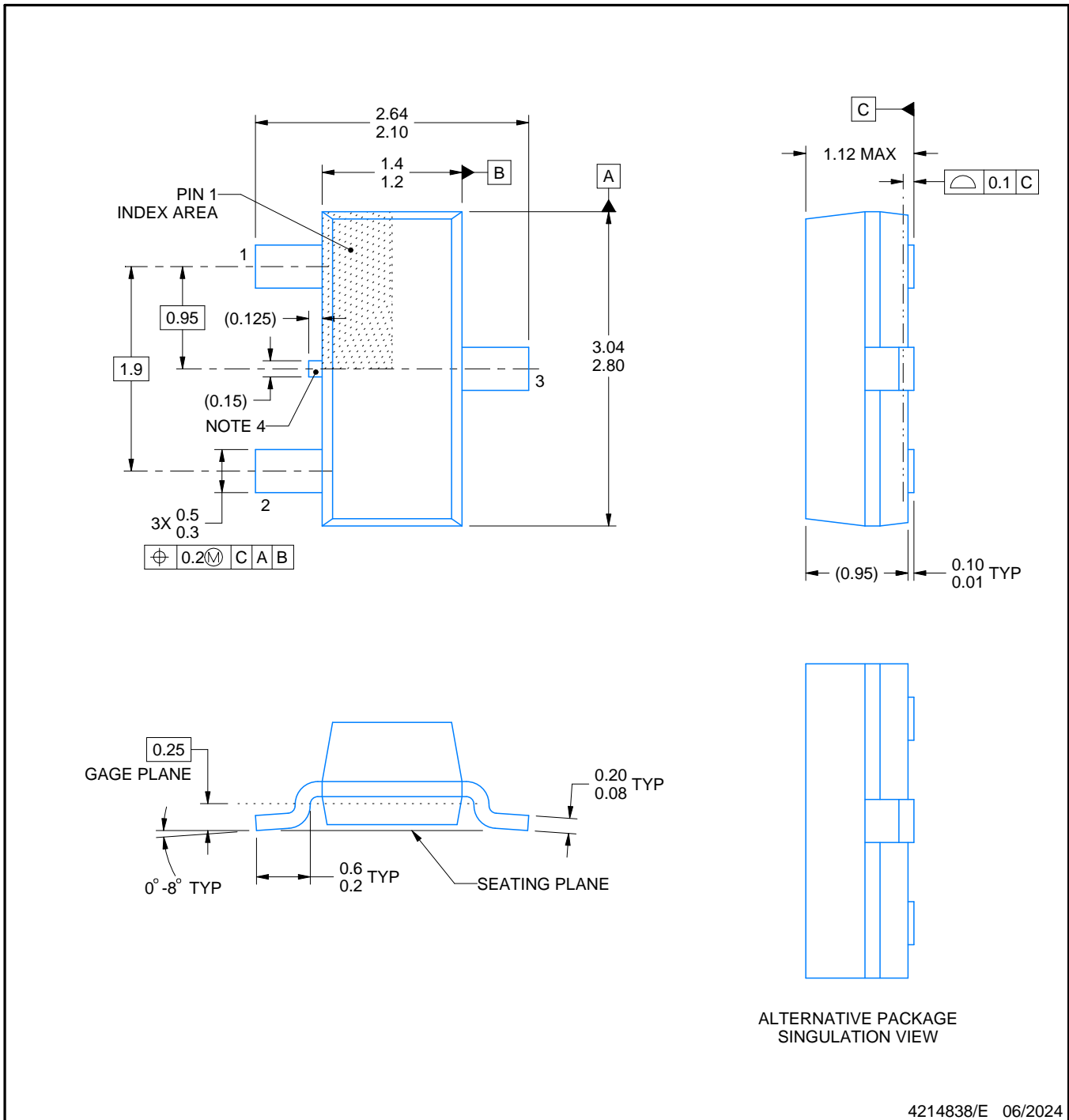
# DBZ0003A



# PACKAGE OUTLINE

## SOT-23 - 1.12 mm max height

SMALL OUTLINE TRANSISTOR



4214838/E 06/2024

### NOTES:

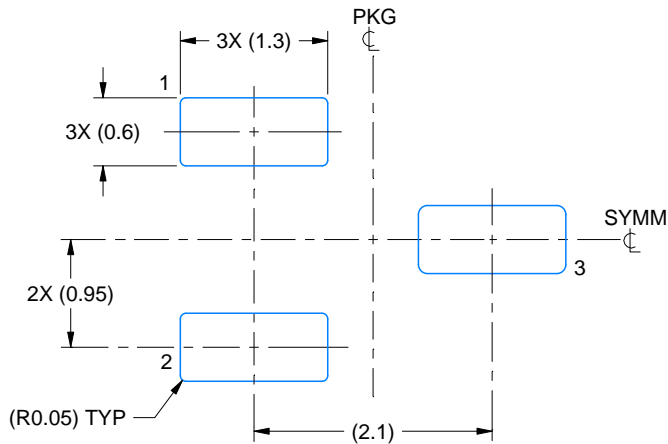
1. All linear dimensions are in millimeters. Any dimensions in parenthesis are for reference only. Dimensioning and tolerancing per ASME Y14.5M.
2. This drawing is subject to change without notice.
3. Reference JEDEC registration TO-236, except minimum foot length.
4. Support pin may differ or may not be present.
5. Body dimensions do not include mold flash, protrusions, or gate burrs. Mold flash, protrusions, or gate burrs shall not exceed 0.25mm per side

# EXAMPLE BOARD LAYOUT

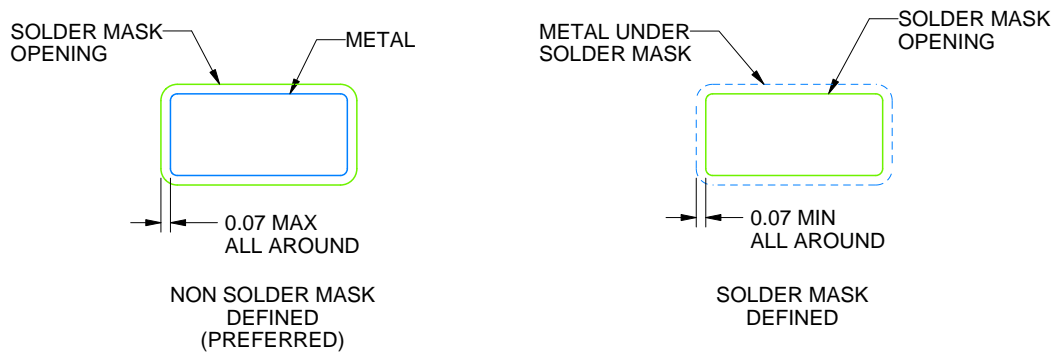
DBZ0003A

SOT-23 - 1.12 mm max height

SMALL OUTLINE TRANSISTOR



LAND PATTERN EXAMPLE  
SCALE:15X



SOLDER MASK DETAILS

4214838/E 06/2024

NOTES: (continued)

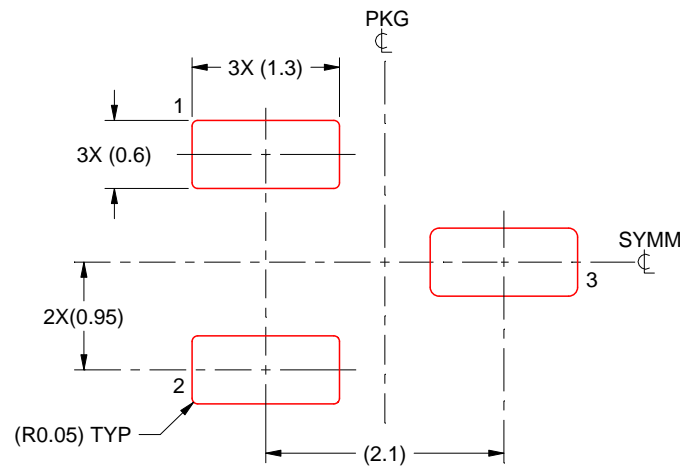
5. Publication IPC-7351 may have alternate designs.
6. Solder mask tolerances between and around signal pads can vary based on board fabrication site.

# EXAMPLE STENCIL DESIGN

DBZ0003A

SOT-23 - 1.12 mm max height

SMALL OUTLINE TRANSISTOR



SOLDER PASTE EXAMPLE  
BASED ON 0.125 THICK STENCIL  
SCALE:15X

4214838/E 06/2024

NOTES: (continued)

7. Laser cutting apertures with trapezoidal walls and rounded corners may offer better paste release. IPC-7525 may have alternate design recommendations.
8. Board assembly site may have different recommendations for stencil design.

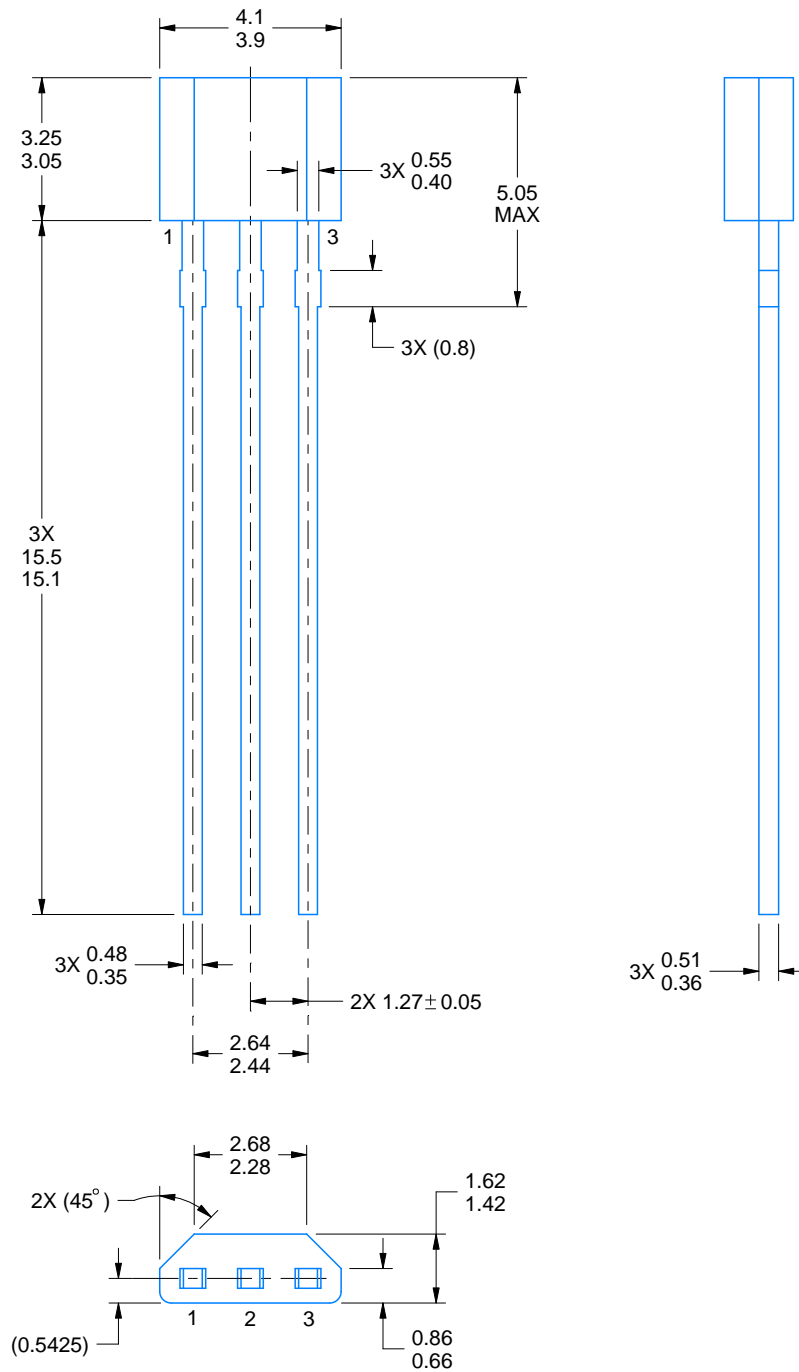
# LPG0003A



# PACKAGE OUTLINE

## TO-92 - 5.05 mm max height

TRANSISTOR OUTLINE



4221343/C 01/2018

### NOTES:

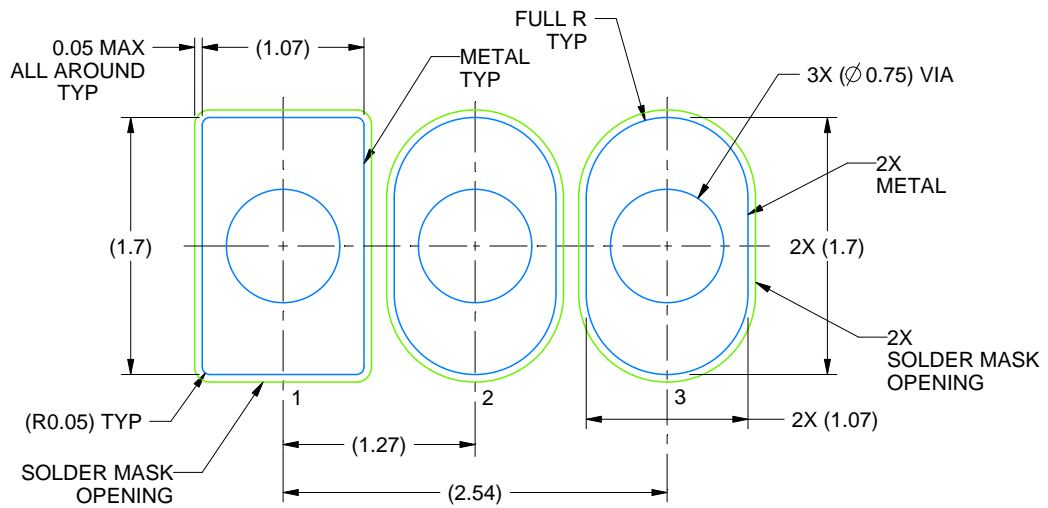
1. All linear dimensions are in millimeters. Any dimensions in parenthesis are for reference only. Dimensioning and tolerancing per ASME Y14.5M.
2. This drawing is subject to change without notice.

# EXAMPLE BOARD LAYOUT

LPG0003A

TO-92 - 5.05 mm max height

TRANSISTOR OUTLINE



LAND PATTERN EXAMPLE  
NON-SOLDER MASK DEFINED  
SCALE:20X

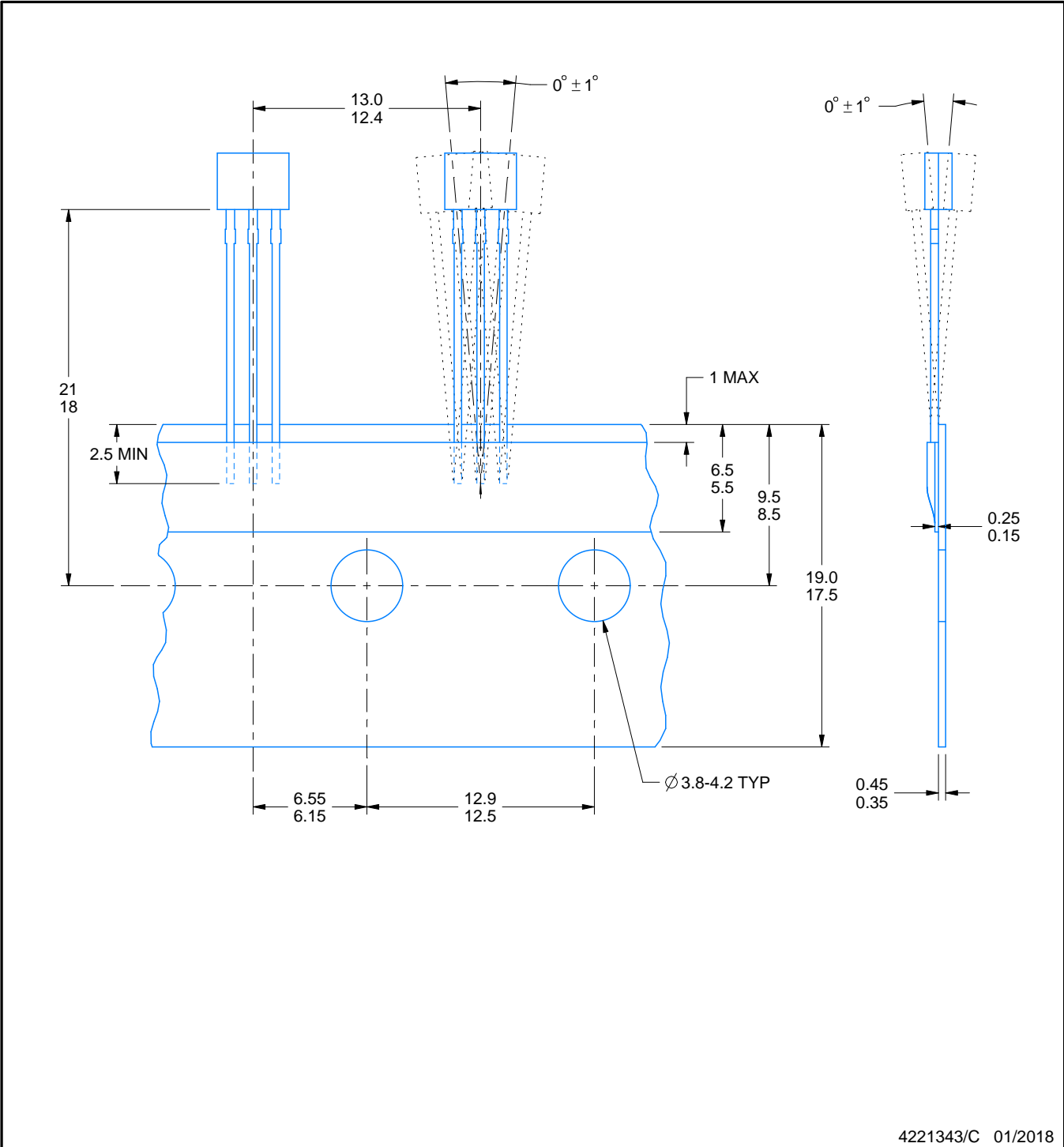
4221343/C 01/2018

# TAPE SPECIFICATIONS

LPG0003A

TO-92 - 5.05 mm max height

TRANSISTOR OUTLINE



4221343/C 01/2018

## IMPORTANT NOTICE AND DISCLAIMER

TI PROVIDES TECHNICAL AND RELIABILITY DATA (INCLUDING DATA SHEETS), DESIGN RESOURCES (INCLUDING REFERENCE DESIGNS), APPLICATION OR OTHER DESIGN ADVICE, WEB TOOLS, SAFETY INFORMATION, AND OTHER RESOURCES "AS IS" AND WITH ALL FAULTS, AND DISCLAIMS ALL WARRANTIES, EXPRESS AND IMPLIED, INCLUDING WITHOUT LIMITATION ANY IMPLIED WARRANTIES OF MERCHANTABILITY, FITNESS FOR A PARTICULAR PURPOSE OR NON-INFRINGEMENT OF THIRD PARTY INTELLECTUAL PROPERTY RIGHTS.

These resources are intended for skilled developers designing with TI products. You are solely responsible for (1) selecting the appropriate TI products for your application, (2) designing, validating and testing your application, and (3) ensuring your application meets applicable standards, and any other safety, security, regulatory or other requirements.

These resources are subject to change without notice. TI grants you permission to use these resources only for development of an application that uses the TI products described in the resource. Other reproduction and display of these resources is prohibited. No license is granted to any other TI intellectual property right or to any third party intellectual property right. TI disclaims responsibility for, and you will fully indemnify TI and its representatives against, any claims, damages, costs, losses, and liabilities arising out of your use of these resources.

TI's products are provided subject to [TI's Terms of Sale](#) or other applicable terms available either on [ti.com](https://www.ti.com) or provided in conjunction with such TI products. TI's provision of these resources does not expand or otherwise alter TI's applicable warranties or warranty disclaimers for TI products.

TI objects to and rejects any additional or different terms you may have proposed.

Mailing Address: Texas Instruments, Post Office Box 655303, Dallas, Texas 75265  
Copyright © 2024, Texas Instruments Incorporated