

LMR12007 Thin SOT23 750mA Load Step-Down DC-DC Regulator

Check for Samples: [LMR12007](#)

FEATURES

- Thin SOT-6 Package
- 3.0V to 18V Input Voltage Range
- 1.25V to 16V Output Voltage Range
- 750mA Output Current
- 550kHz (LMR12007Y) and 1.6MHz (LMR12007X) Switching Frequencies
- 350mΩ NMOS Switch
- 30nA Shutdown Current
- 1.25V, 2% Internal Voltage Reference
- Internal Soft-Start
- Current-Mode, PWM Operation
- WEBENCH® Online Design Tool
- Thermal Shutdown

APPLICATIONS

- Local Point of Load Regulation
- Core Power in HDDs
- Set-Top Boxes
- Battery Powered Devices
- USB Powered Devices
- DSL Modems
- Notebook Computers

DESCRIPTION

The LMR12007 regulator is a monolithic, high frequency, PWM step-down DC/DC converter in a 6-pin Thin SOT package. It provides all the active functions to provide local DC/DC conversion with fast transient response and accurate regulation in the smallest possible PCB area.

With a minimum of external components and online design support through WEBENCH®, the LMR12007 is easy to use. The ability to drive 750mA loads with an internal 350mΩ NMOS switch using state-of-the-art 0.5µm BiCMOS technology results in the best power density available. The world class control circuitry allows for on-times as low as 13ns, thus supporting exceptionally high frequency conversion over the entire 3V to 18V input operating range down to the minimum output voltage of 1.25V. Switching frequency is internally set to 550kHz (LMR12007Y) or 1.6MHz (LMR12007X), allowing the use of extremely small surface mount inductors and chip capacitors. Even though the operating frequencies are very high, efficiencies up to 90% are easy to achieve. External shutdown is included, featuring an ultra-low stand-by current of 30nA. The LMR12007 utilizes current-mode control and internal compensation to provide high-performance regulation over a wide range of operating conditions. Additional features include internal soft-start circuitry to reduce inrush current, pulse-by-pulse current limit, thermal shutdown, and output over-voltage protection.

Typical Application Circuit

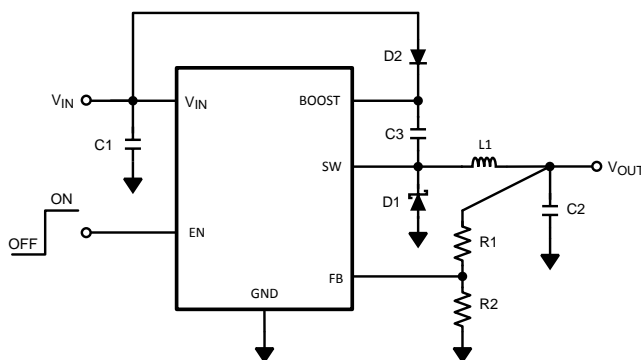

Efficiency vs Load Current "X"
VIN = 5V, VOUT = 3.3V

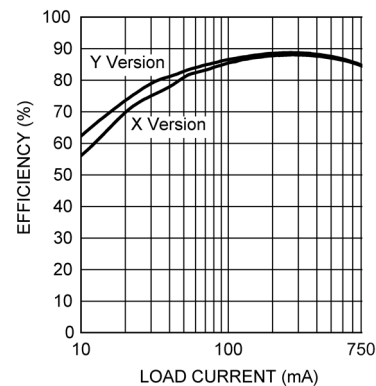

Please be aware that an important notice concerning availability, standard warranty, and use in critical applications of Texas Instruments semiconductor products and disclaimers thereto appears at the end of this data sheet.

WEBENCH is a registered trademark of Texas Instruments.

All other trademarks are the property of their respective owners.

Connection Diagram

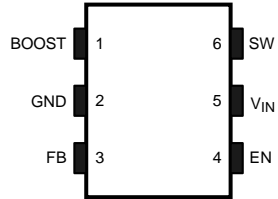

Figure 1. 6-Lead SOT
See Package Number DDC (R-PDSO-G6)

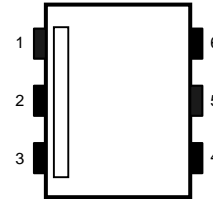

Figure 2. Pin 1 Identification

PIN DESCRIPTIONS

Pin	Name	Function
1	BOOST	Boost voltage that drives the internal NMOS control switch. A bootstrap capacitor is connected between the BOOST and SW pins.
2	GND	Signal and Power ground pin. Place the bottom resistor of the feedback network as close as possible to this pin for accurate regulation.
3	FB	Feedback pin. Connect FB to the external resistor divider to set output voltage.
4	EN	Enable control input. Logic high enables operation. Do not allow this pin to float or be greater than $V_{IN} + 0.3V$.
5	V_{IN}	Input supply voltage. Connect a bypass capacitor to this pin.
6	SW	Output switch. Connects to the inductor, catch diode, and bootstrap capacitor.



These devices have limited built-in ESD protection. The leads should be shorted together or the device placed in conductive foam during storage or handling to prevent electrostatic damage to the MOS gates.

Absolute Maximum Ratings⁽¹⁾

V_{IN}		-0.5V to 22V
SW Voltage		-0.5V to 22V
Boost Voltage		-0.5V to 28V
Boost to SW Voltage		-0.5V to 6.0V
FB Voltage		-0.5V to 3.0V
EN Voltage		-0.5V to ($V_{IN} + 0.3V$)
Junction Temperature		150°C
ESD Susceptibility ⁽²⁾		2kV
Storage Temp. Range		-65°C to 150°C
Soldering Information	Infrared/Convection Reflow (15sec)	220°C
	Wave Soldering Lead Temp. (10sec)	260°C

(1) If Military/Aerospace specified devices are required, please contact the Texas Instruments Sales Office/ Distributors for availability and specifications.

(2) Human body model, 1.5kΩ in series with 100pF.

Operating Ratings⁽¹⁾

V _{IN}	3V to 18V
SW Voltage	-0.5V to 18V
Boost Voltage	-0.5V to 23V
Boost to SW Voltage	1.6V to 5.5V
Junction Temperature Range	-40°C to +125°C
Thermal Resistance θ_{JA} ⁽²⁾	118°C/W

- (1) Absolute Maximum Ratings indicate limits beyond which damage to the device may occur. Operating Ratings indicate conditions for which the device is intended to be functional, but specific performance is not ensured. For specific specifications and the test conditions, see Electrical Characteristics.
- (2) Thermal shutdown will occur if the junction temperature exceeds 165°C. The maximum power dissipation is a function of T_{J(MAX)}, θ_{JA} and T_A. The maximum allowable power dissipation at any ambient temperature is P_D = (T_{J(MAX)} - T_A)/ θ_{JA} . All numbers apply for packages soldered directly onto a 3" x 3" PC board with 2oz. copper on 4 layers in still air. For a 2 layer board using 1 oz. copper in still air, θ_{JA} = 204°C/W.

Electrical Characteristics

Specifications with standard typeface are for T_J = 25°C, and those in **boldface type** apply over the full **Operating Temperature Range** (T_J = -40°C to 125°C). V_{IN} = 5V, V_{BOOST} - V_{SW} = 5V unless otherwise specified. Datasheet min/max specification limits are ensured by design, test, or statistical analysis.

Symbol	Parameter	Conditions	Min ⁽¹⁾	Typ ⁽²⁾	Max ⁽¹⁾	Units
V _{FB}	Feedback Voltage		1.225	1.250	1.275	V
$\Delta V_{FB}/\Delta V_{IN}$	Feedback Voltage Line Regulation	V _{IN} = 3V to 18V		0.01		% / V
I _{FB}	Feedback Input Bias Current	Sink/Source		10	250	nA
UVLO	Undervoltage Lockout	V _{IN} Rising		2.74	2.90	V
	Undervoltage Lockout	V _{IN} Falling	2.0	2.3		
	UVLO Hysteresis		0.30	0.44	0.62	
F _{SW}	Switching Frequency	LMR12007X	1.2	1.6	1.9	MHz
		LMR12007Y	0.40	0.55	0.66	
D _{MAX}	Maximum Duty Cycle	LMR12007X	85	92		%
		LMR12007Y	90	96		
D _{MIN}	Minimum Duty Cycle	LMR12007X		2		%
		LMR12007Y		1		
R _{DS(ON)}	Switch ON Resistance	V _{BOOST} - V _{SW} = 3V		350	650	mΩ
I _{CL}	Switch Current Limit	V _{BOOST} - V _{SW} = 3V	1.0	1.5	2.3	A
I _Q	Quiescent Current	Switching		1.5	2.5	mA
	Quiescent Current (shutdown)	V _{EN} = 0V		30		
I _{BOOST}	Boost Pin Current	LMR12007X (50% Duty Cycle)		2.2	3.3	mA
		LMR12007Y (50% Duty Cycle)		0.9	1.6	
V _{EN_TH}	Shutdown Threshold Voltage	V _{EN} Falling			0.4	V
	Enable Threshold Voltage	V _{EN} Rising	1.8			
I _{EN}	Enable Pin Current	Sink/Source		10		nA
I _{SW}	Switch Leakage			40		nA

- (1) Specified to Texas Instruments' Average Outgoing Quality Level (AOQL).
- (2) Typicals represent the most likely parametric norm.

Typical Performance Characteristics

All curves taken at $V_{IN} = 5V$, $V_{BOOST} - V_{SW} = 5V$, $L1 = 4.7 \mu H$ ("X"), $L1 = 10 \mu H$ ("Y"), and $T_A = 25^\circ C$, unless specified otherwise.

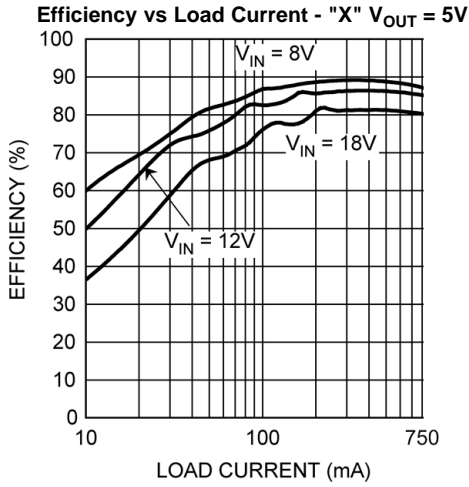

Figure 3.

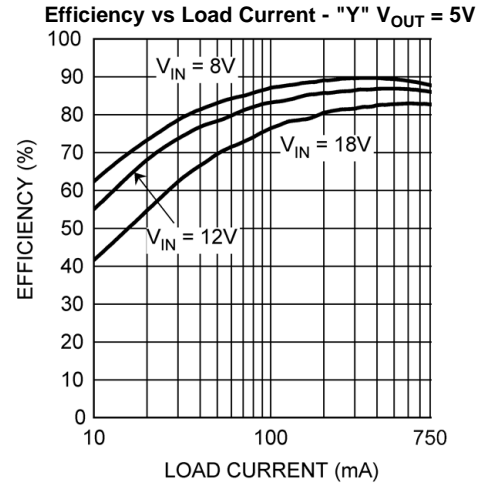

Figure 4.

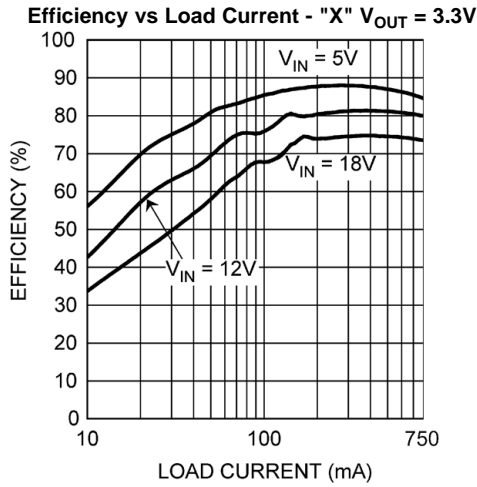

Figure 5.

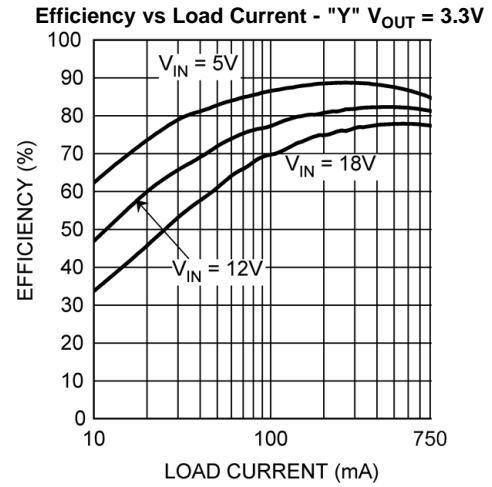

Figure 6.

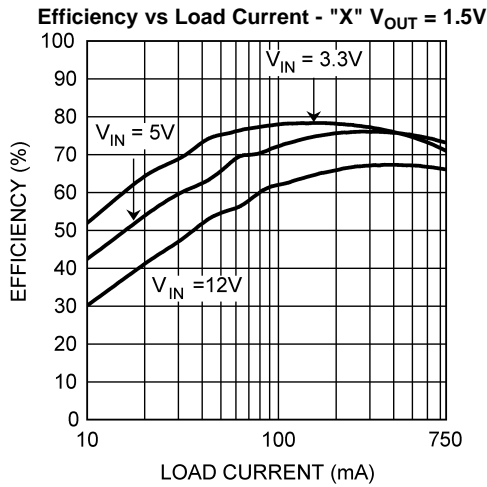

Figure 7.

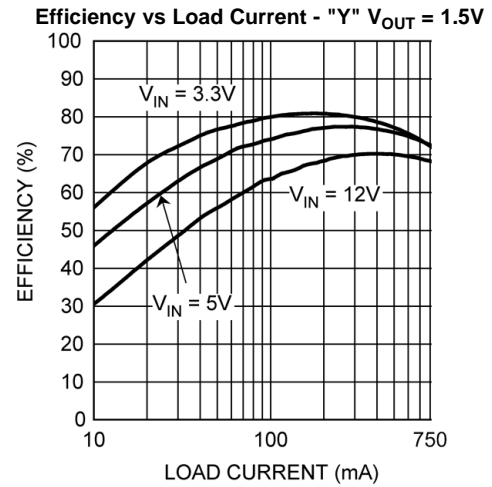

Figure 8.

Typical Performance Characteristics (continued)

All curves taken at $V_{IN} = 5V$, $V_{BOOST} - V_{SW} = 5V$, $L1 = 4.7 \mu H$ ("X"), $L1 = 10 \mu H$ ("Y"), and $T_A = 25^\circ C$, unless specified otherwise.

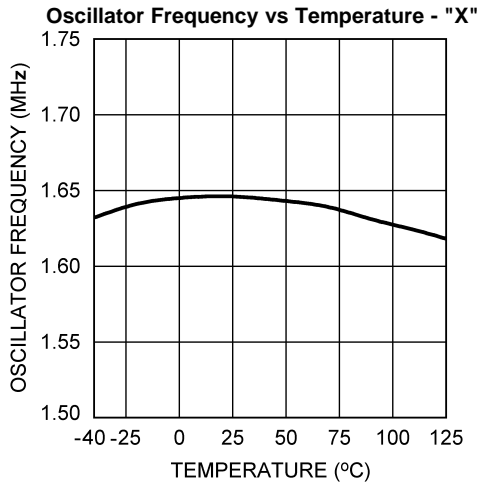

Figure 9.

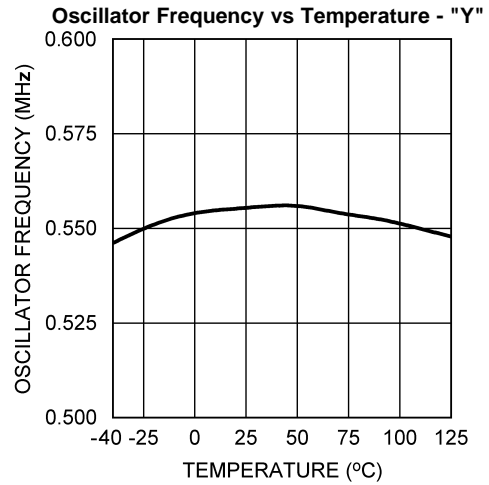

Figure 10.

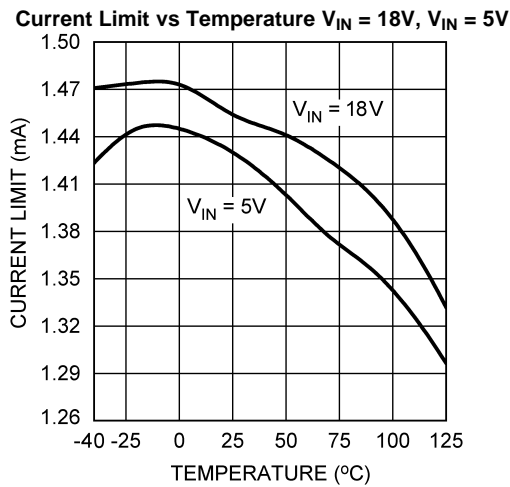

Figure 11.

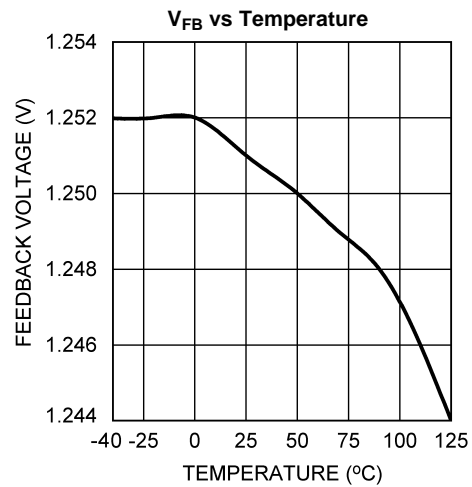

Figure 12.

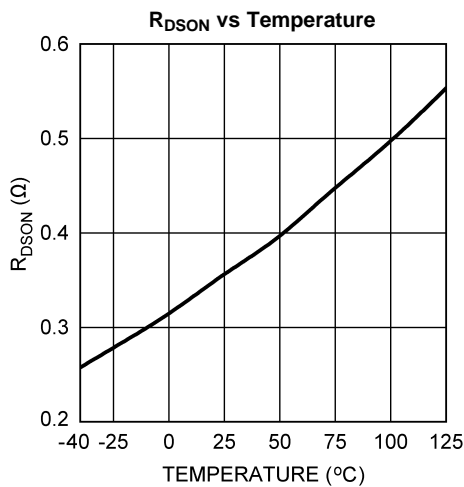

Figure 13.

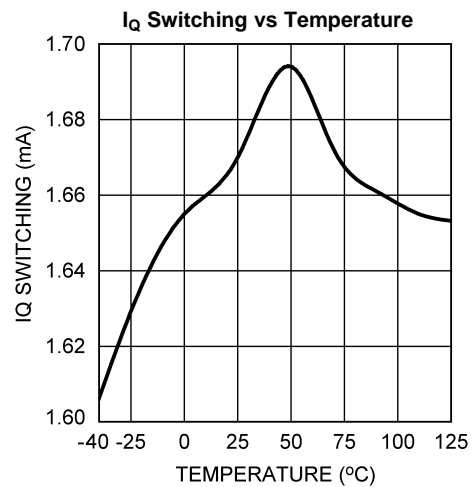

Figure 14.

Typical Performance Characteristics (continued)

All curves taken at $V_{IN} = 5V$, $V_{BOOST} - V_{SW} = 5V$, $L1 = 4.7 \mu H$ ("X"), $L1 = 10 \mu H$ ("Y"), and $T_A = 25^\circ C$, unless specified otherwise.

Line Regulation - "X" $V_{OUT} = 1.5V$, $I_{OUT} = 500mA$

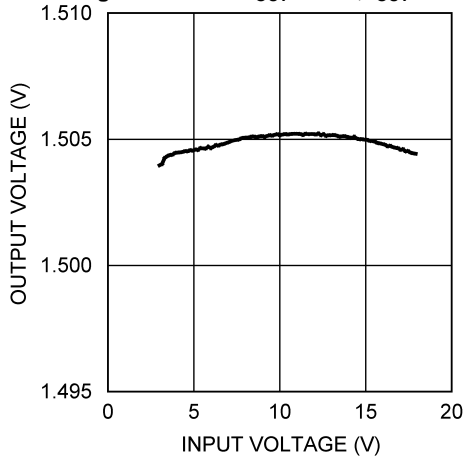

Figure 15.

Line Regulation - "Y" $V_{OUT} = 1.5V$, $I_{OUT} = 500mA$

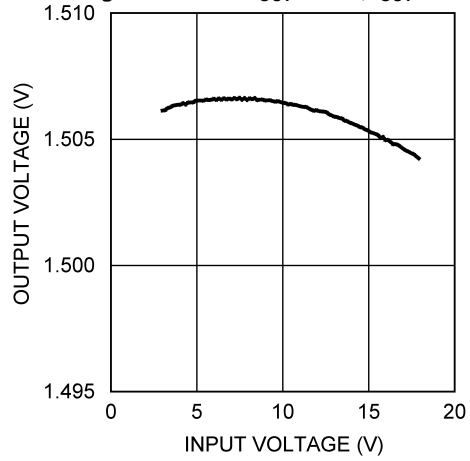

Figure 16.

Line Regulation - "X" $V_{OUT} = 3.3V$, $I_{OUT} = 500mA$

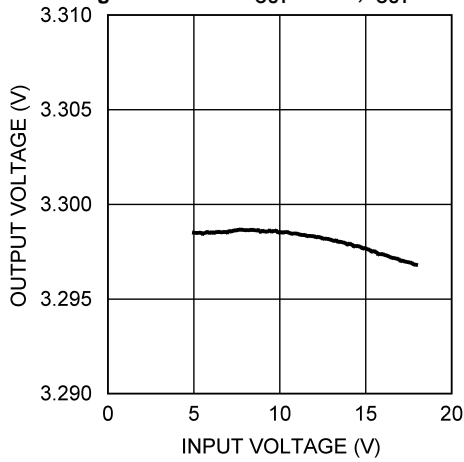

Figure 17.

Line Regulation - "Y" $V_{OUT} = 3.3V$, $I_{OUT} = 500mA$

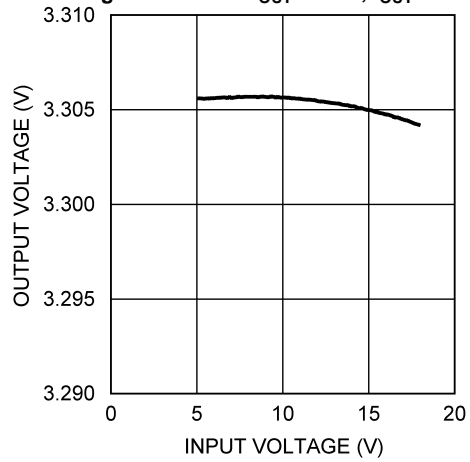

Figure 18.

Block Diagram

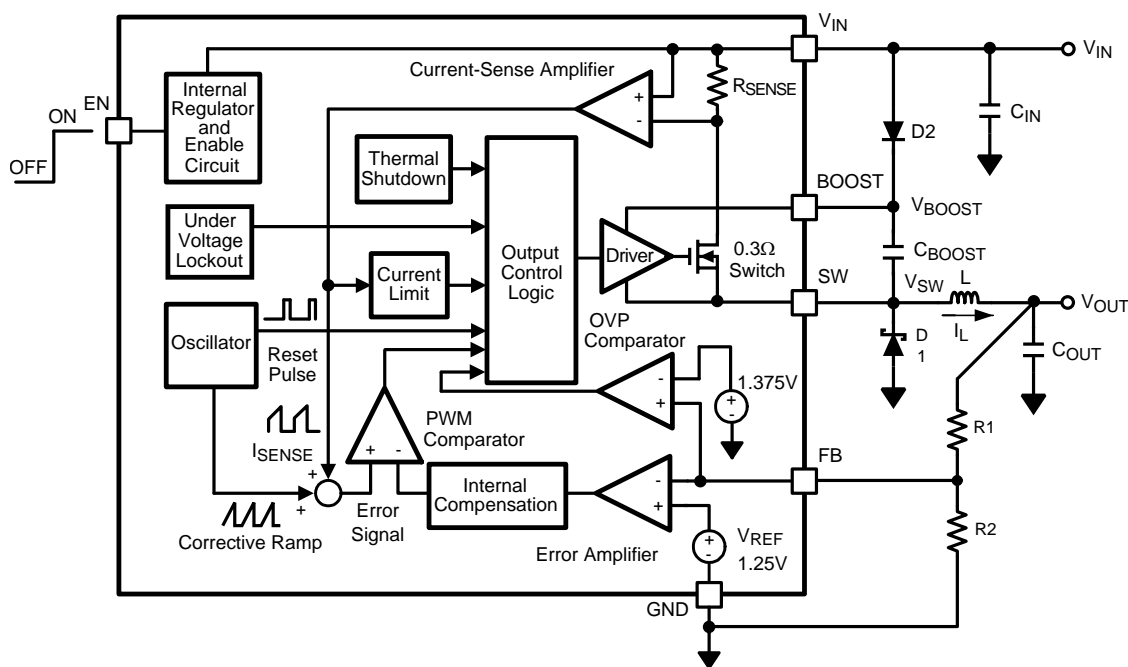

Figure 19.

APPLICATION INFORMATION

THEORY OF OPERATION

The LMR12007 is a constant frequency PWM buck regulator IC that delivers a 750mA load current. The regulator has a preset switching frequency of either 550kHz (LMR12007Y) or 1.6MHz (LMR12007X). These high frequencies allow the LMR12007 to operate with small surface mount capacitors and inductors, resulting in DC/DC converters that require a minimum amount of board space. The LMR12007 is internally compensated, so it is simple to use, and requires few external components. The LMR12007 uses current-mode control to regulate the output voltage.

The following operating description of the LMR12007 will refer to the Simplified Block Diagram (Figure 19) and to the waveforms in Figure 20. The LMR12007 supplies a regulated output voltage by switching the internal NMOS control switch at constant frequency and variable duty cycle. A switching cycle begins at the falling edge of the reset pulse generated by the internal oscillator. When this pulse goes low, the output control logic turns on the internal NMOS control switch. During this on-time, the SW pin voltage (V_{SW}) swings up to approximately V_{IN} , and the inductor current (I_L) increases with a linear slope. I_L is measured by the current-sense amplifier, which generates an output proportional to the switch current. The sense signal is summed with the regulator's corrective ramp and compared to the error amplifier's output, which is proportional to the difference between the feedback voltage and V_{REF} . When the PWM comparator output goes high, the output switch turns off until the next switching cycle begins. During the switch off-time, inductor current discharges through Schottky diode D1, which forces the SW pin to swing below ground by the forward voltage (V_D) of the catch diode. The regulator loop adjusts the duty cycle (D) to maintain a constant output voltage.

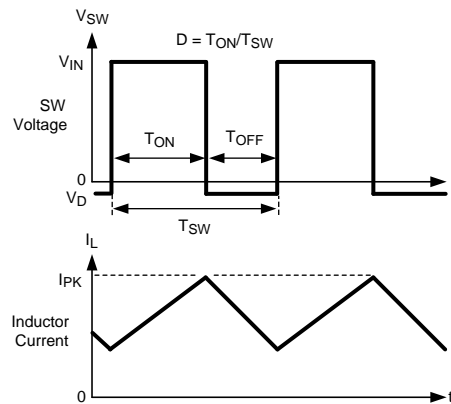

Figure 20. LMR12007 Waveforms of SW Pin Voltage and Inductor Current

BOOST FUNCTION

Capacitor C_{BOOST} and diode D2 in [Figure 21](#) are used to generate a voltage V_{BOOST} . $V_{\text{BOOST}} - V_{\text{SW}}$ is the gate drive voltage to the internal NMOS control switch. To properly drive the internal NMOS switch during its on-time, V_{BOOST} needs to be at least 1.6V greater than V_{SW} . Although the LMR12007 will operate with this minimum voltage, it may not have sufficient gate drive to supply large values of output current. Therefore, it is recommended that V_{BOOST} be greater than 2.5V above V_{SW} for best efficiency. $V_{\text{BOOST}} - V_{\text{SW}}$ should not exceed the maximum operating limit of 5.5V.

$5.5\text{V} > V_{\text{BOOST}} - V_{\text{SW}} > 2.5\text{V}$ for best performance.

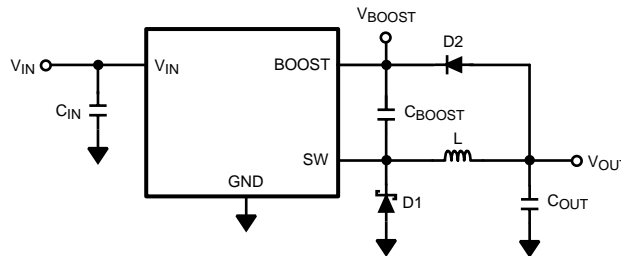

Figure 21. V_{OUT} Charges C_{BOOST}

When the LMR12007 starts up, internal circuitry from the BOOST pin supplies a maximum of 20mA to C_{BOOST} . This current charges C_{BOOST} to a voltage sufficient to turn the switch on. The BOOST pin will continue to source current to C_{BOOST} until the voltage at the feedback pin is greater than 1.18V.

There are various methods to derive V_{BOOST} :

1. From the input voltage (V_{IN})
2. From the output voltage (V_{OUT})
3. From an external distributed voltage rail (V_{EXT})
4. From a shunt or series zener diode

In the Simplified Block Diagram of [Figure 19](#), capacitor C_{BOOST} and diode D2 supply the gate-drive current for the NMOS switch. Capacitor C_{BOOST} is charged via diode D2 by V_{IN} . During a normal switching cycle, when the internal NMOS control switch is off (T_{OFF}) (refer to [Figure 20](#)), V_{BOOST} equals V_{IN} minus the forward voltage of D2 (V_{FD2}), during which the current in the inductor (L) forward biases the Schottky diode D1 (V_{FD1}). Therefore the voltage stored across C_{BOOST} is

$$V_{\text{BOOST}} - V_{\text{SW}} = V_{\text{IN}} - V_{\text{FD2}} + V_{\text{FD1}} \quad (1)$$

When the NMOS switch turns on (T_{ON}), the switch pin rises to

$$V_{SW} = V_{IN} - (R_{DSON} \times I_L), \quad (2)$$

forcing V_{BOOST} to rise thus reverse biasing D2. The voltage at V_{BOOST} is then

$$V_{BOOST} = 2V_{IN} - (R_{DSON} \times I_L) - V_{FD2} + V_{FD1} \quad (3)$$

which is approximately

$$2V_{IN} - 0.4V \quad (4)$$

for many applications. Thus the gate-drive voltage of the NMOS switch is approximately

$$V_{IN} - 0.2V \quad (5)$$

An alternate method for charging C_{BOOST} is to connect D2 to the output as shown in Figure 21. The output voltage should be between 2.5V and 5.5V, so that proper gate voltage will be applied to the internal switch. In this circuit, C_{BOOST} provides a gate drive voltage that is slightly less than V_{OUT} .

In applications where both V_{IN} and V_{OUT} are greater than 5.5V, or less than 3V, C_{BOOST} cannot be charged directly from these voltages. If V_{IN} and V_{OUT} are greater than 5.5V, C_{BOOST} can be charged from V_{IN} or V_{OUT} minus a zener voltage by placing a zener diode D3 in series with D2, as shown in Figure 22. When using a series zener diode from the input, ensure that the regulation of the input supply doesn't create a voltage that falls outside the recommended V_{BOOST} voltage.

$$(V_{INMAX} - V_{D3}) < 5.5V$$

$$(V_{INMIN} - V_{D3}) > 1.6V$$

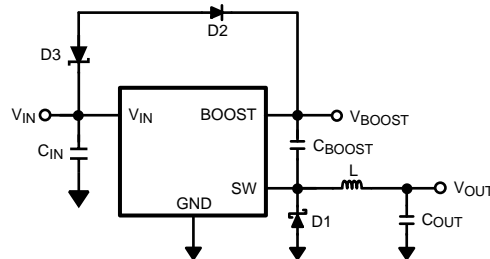

Figure 22. Zener Reduces Boost Voltage from V_{IN}

An alternative method is to place the zener diode D3 in a shunt configuration as shown in Figure 23. A small 350mW to 500mW 5.1V zener in a SOT or SOD package can be used for this purpose. A small ceramic capacitor such as a 6.3V, 0.1 μ F capacitor (C_4) should be placed in parallel with the zener diode. When the internal NMOS switch turns on, a pulse of current is drawn to charge the internal NMOS gate capacitance. The 0.1 μ F parallel shunt capacitor ensures that the V_{BOOST} voltage is maintained during this time.

Resistor R3 should be chosen to provide enough RMS current to the zener diode (D3) and to the BOOST pin. A recommended choice for the zener current (I_{ZENER}) is 1 mA. The current I_{BOOST} into the BOOST pin supplies the gate current of the NMOS control switch and varies typically according to the following formula for the X - version:

$$I_{BOOST} = 0.49 \times (D + 0.54) \times (V_{ZENER} - V_{D2}) \text{ mA} \quad (6)$$

I_{BOOST} can be calculated for the Y version using the following:

$$I_{BOOST} = 0.20 \times (D + 0.54) \times (V_{ZENER} - V_{D2}) \mu\text{A} \quad (7)$$

where D is the duty cycle, V_{ZENER} and V_{D2} are in volts, and I_{BOOST} is in milliamps. V_{ZENER} is the voltage applied to the anode of the boost diode (D2), and V_{D2} is the average forward voltage across D2. Note that this formula for I_{BOOST} gives typical current. For the worst case I_{BOOST} , increase the current by 40%. In that case, the worst case boost current will be

$$I_{BOOST-MAX} = 1.4 \times I_{BOOST} \quad (8)$$

R3 will then be given by

$$R3 = (V_{IN} - V_{ZENER}) / (1.4 \times I_{BOOST} + I_{ZENER}) \quad (9)$$

For example, using the X-version let $V_{IN} = 10V$, $V_{ZENER} = 5V$, $V_{D2} = 0.7V$, $I_{ZENER} = 1\text{mA}$, and duty cycle $D = 50\%$. Then

$$I_{\text{BOOST}} = 0.49 \times (0.5 + 0.54) \times (5 - 0.7) \text{ mA} = 2.19 \text{ mA} \quad (10)$$

$$R3 = (10\text{V} - 5\text{V}) / (1.4 \times 2.19 \text{ mA} + 1 \text{ mA}) = 1.23 \text{ k}\Omega \quad (11)$$

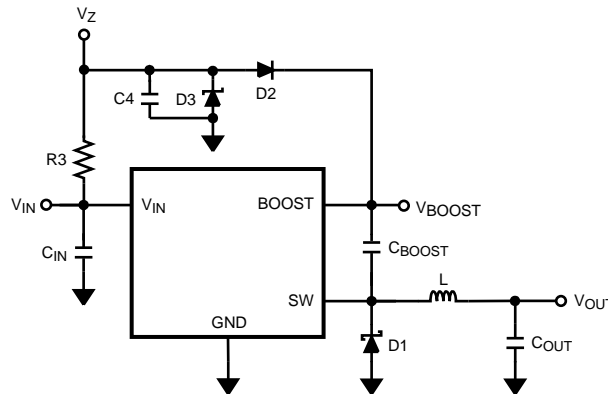

Figure 23. Boost Voltage Supplied from the Shunt Zener on V_{IN}

ENABLE PIN / SHUTDOWN MODE

The LMR12007 has a shutdown mode that is controlled by the enable pin (EN). When a logic low voltage is applied to EN, the part is in shutdown mode and its quiescent current drops to typically 30nA. Switch leakage adds another 40nA from the input supply. The voltage at this pin should never exceed $V_{\text{IN}} + 0.3\text{V}$.

SOFT-START

This function forces V_{OUT} to increase at a controlled rate during start up. During soft-start, the error amplifier's reference voltage ramps from 0V to its nominal value of 1.25V in approximately 200 μs . This forces the regulator output to ramp up in a more linear and controlled fashion, which helps reduce inrush current.

OUTPUT OVERVOLTAGE PROTECTION

The overvoltage comparator compares the FB pin voltage to a voltage that is 10% higher than the internal reference V_{ref} . Once the FB pin voltage goes 10% above the internal reference, the internal NMOS control switch is turned off, which allows the output voltage to decrease toward regulation.

UNDERVOLTAGE LOCKOUT

Undervoltage lockout (UVLO) prevents the LMR12007 from operating until the input voltage exceeds 2.74V(typ).

The UVLO threshold has approximately 440mV of hysteresis, so the part will operate until V_{IN} drops below 2.3V(typ). Hysteresis prevents the part from turning off during power up if V_{IN} is non-monotonic.

CURRENT LIMIT

The LMR12007 uses cycle-by-cycle current limiting to protect the output switch. During each switching cycle, a current limit comparator detects if the output switch current exceeds 1.5A (typ), and turns off the switch until the next switching cycle begins.

THERMAL SHUTDOWN

Thermal shutdown limits total power dissipation by turning off the output switch when the IC junction temperature exceeds 165°C. After thermal shutdown occurs, the output switch doesn't turn on until the junction temperature drops to approximately 150°C.

Design Guide

INDUCTOR SELECTION

The Duty Cycle (D) can be approximated quickly using the ratio of output voltage (V_O) to input voltage (V_{IN}):

$$D = \frac{V_O}{V_{IN}} \quad (12)$$

The catch diode (D_1) forward voltage drop and the voltage drop across the internal NMOS must be included to calculate a more accurate duty cycle. Calculate D by using the following formula:

$$D = \frac{V_O + V_D}{V_{IN} + V_D - V_{SW}} \quad (13)$$

V_{SW} can be approximated by:

$$V_{SW} = I_O \times R_{DS(ON)} \quad (14)$$

The diode forward drop (V_D) can range from 0.3V to 0.7V depending on the quality of the diode. The lower V_D is, the higher the operating efficiency of the converter.

The inductor value determines the output ripple current. Lower inductor values decrease the size of the inductor, but increase the output ripple current. An increase in the inductor value will decrease the output ripple current. The ratio of ripple current (ΔI_L) to output current (I_O) is optimized when it is set between 0.3 and 0.4 at 750mA. The ratio r is defined as:

$$r = \frac{\Delta I_L}{I_O} \quad (15)$$

One must also ensure that the minimum current limit (1.0A) is not exceeded, so the peak current in the inductor must be calculated. The peak current (I_{LPK}) in the inductor is calculated by:

$$I_{LPK} = I_O + \Delta I_L / 2 \quad (16)$$

If $r = 0.7$ at an output of 750mA, the peak current in the inductor will be 1.0125A. The minimum ensured current limit over all operating conditions is 1.0A. One can either reduce r to 0.6 resulting in a 975mA peak current, or make the engineering judgement that 12.5mA over will be safe enough with a 1.5A typical current limit and 6 sigma limits. When the designed maximum output current is reduced, the ratio r can be increased. At a current of 0.1A, r can be made as high as 0.9. The ripple ratio can be increased at lighter loads because the net ripple is actually quite low, and if r remains constant the inductor value can be made quite large. An equation empirically developed for the maximum ripple ratio at any current below 2A is:

$$r = 0.387 \times I_{OUT}^{-0.3667} \quad (17)$$

Note that this is just a guideline.

The LMR12007 operates at frequencies allowing the use of ceramic output capacitors without compromising transient response. Ceramic capacitors allow higher inductor ripple without significantly increasing output ripple. See the [OUTPUT CAPACITOR](#) section for more details on calculating output voltage ripple.

Now that the ripple current or ripple ratio is determined, the inductance is calculated by:

$$L = \frac{V_O + V_D}{I_O \times r \times f_s} \times (1-D) \quad (18)$$

where f_s is the switching frequency and I_O is the output current. When selecting an inductor, make sure that it is capable of supporting the peak output current without saturating. Inductor saturation will result in a sudden reduction in inductance and prevent the regulator from operating correctly. Because of the speed of the internal current limit, the peak current of the inductor need only be specified for the required maximum output current. For example, if the designed maximum output current is 0.5A and the peak current is 0.7A, then the inductor should

be specified with a saturation current limit of >0.7A. There is no need to specify the saturation or peak current of the inductor at the 1.5A typical switch current limit. The difference in inductor size is a factor of 5. Because of the operating frequency of the LMR12007, ferrite based inductors are preferred to minimize core losses. This presents little restriction since the variety of ferrite based inductors is huge. Lastly, inductors with lower series resistance (DCR) will provide better operating efficiency. For recommended inductors see Example Circuits.

INPUT CAPACITOR

An input capacitor is necessary to ensure that V_{IN} does not drop excessively during switching transients. The primary specifications of the input capacitor are capacitance, voltage, RMS current rating, and ESL (Equivalent Series Inductance). The recommended input capacitance is 10 μ F, although 4.7 μ F works well for input voltages below 6V. The input voltage rating is specifically stated by the capacitor manufacturer. Make sure to check any recommended deratings and also verify if there is any significant change in capacitance at the operating input voltage and the operating temperature. The input capacitor maximum RMS input current rating (I_{RMS-IN}) must be greater than:

$$I_{RMS-IN} = I_O \times \sqrt{D \times \left(1-D + \frac{r^2}{12}\right)} \quad (19)$$

It can be shown from the above equation that maximum RMS capacitor current occurs when $D = 0.5$. Always calculate the RMS at the point where the duty cycle, D , is closest to 0.5. The ESL of an input capacitor is usually determined by the effective cross sectional area of the current path. A large leaded capacitor will have high ESL and a 0805 ceramic chip capacitor will have very low ESL. At the operating frequencies of the LMR12007, certain capacitors may have an ESL so large that the resulting impedance ($2\pi fL$) will be higher than that required to provide stable operation. As a result, surface mount capacitors are strongly recommended. Sanyo POSCAP, Tantalum or Niobium, Panasonic SP or Cornell Dubilier ESR, and multilayer ceramic capacitors (MLCC) are all good choices for both input and output capacitors and have very low ESL. For MLCCs it is recommended to use X7R or X5R dielectrics. Consult capacitor manufacturer datasheet to see how rated capacitance varies over operating conditions.

OUTPUT CAPACITOR

The output capacitor is selected based upon the desired output ripple and transient response. The initial current of a load transient is provided mainly by the output capacitor. The output ripple of the converter is:

$$\Delta V_O = \Delta i_L \times \left(R_{ESR} + \frac{1}{8 \times f_s \times C_O} \right) \quad (20)$$

When using MLCCs, the ESR is typically so low that the capacitive ripple may dominate. When this occurs, the output ripple will be approximately sinusoidal and 90° phase shifted from the switching action. Given the availability and quality of MLCCs and the expected output voltage of designs using the LMR12007, there is really no need to review any other capacitor technologies. Another benefit of ceramic capacitors is their ability to bypass high frequency noise. A certain amount of switching edge noise will couple through parasitic capacitances in the inductor to the output. A ceramic capacitor will bypass this noise while a tantalum will not. Since the output capacitor is one of the two external components that control the stability of the regulator control loop, most applications will require a minimum at 10 μ F of output capacitance. Capacitance can be increased significantly with little detriment to the regulator stability. Like the input capacitor, recommended multilayer ceramic capacitors are X7R or X5R. Again, verify actual capacitance at the desired operating voltage and temperature.

Check the RMS current rating of the capacitor. The RMS current rating of the capacitor chosen must also meet the following condition:

$$I_{RMS-OUT} = I_O \times \frac{r}{\sqrt{12}} \quad (21)$$

CATCH DIODE

The catch diode (D1) conducts during the switch off-time. A Schottky diode is recommended for its fast switching times and low forward voltage drop. The catch diode should be chosen so that its current rating is greater than:

$$I_{D1} = I_O \times (1-D) \quad (22)$$

The reverse breakdown rating of the diode must be at least the maximum input voltage plus appropriate margin. To improve efficiency choose a Schottky diode with a low forward voltage drop.

BOOST DIODE

A standard diode such as the 1N4148 type is recommended. For V_{BOOST} circuits derived from voltages less than 3.3V, a small-signal Schottky diode is recommended for greater efficiency. A good choice is the BAT54 small signal diode.

BOOST CAPACITOR

A ceramic 0.01 μ F capacitor with a voltage rating of at least 6.3V is sufficient. The X7R and X5R MLCCs provide the best performance.

OUTPUT VOLTAGE

The output voltage is set using the following equation where R2 is connected between the FB pin and GND, and R1 is connected between V_O and the FB pin. A good value for R2 is 10k Ω .

$$R1 = \left(\frac{V_O}{V_{REF}} - 1 \right) \times R2 \quad (23)$$

PCB Layout Considerations

When planning layout there are a few things to consider when trying to achieve a clean, regulated output. The most important consideration when completing the layout is the close coupling of the GND connections of the C_{IN} capacitor and the catch diode D1. These ground ends should be close to one another and be connected to the GND plane with at least two through-holes. Place these components as close to the IC as possible. Next in importance is the location of the GND connection of the C_{OUT} capacitor, which should be near the GND connections of C_{IN} and D1.

There should be a continuous ground plane on the bottom layer of a two-layer board except under the switching node island.

The FB pin is a high impedance node and care should be taken to make the FB trace short to avoid noise pickup and inaccurate regulation. The feedback resistors should be placed as close as possible to the IC, with the GND of R2 placed as close as possible to the GND of the IC. The V_{OUT} trace to R1 should be routed away from the inductor and any other traces that are switching.

High AC currents flow through the V_{IN} , SW and V_{OUT} traces, so they should be as short and wide as possible. However, making the traces wide increases radiated noise, so the designer must make this trade-off. Radiated noise can be decreased by choosing a shielded inductor.

The remaining components should also be placed as close as possible to the IC. Please see Application Note AN-1229 [SNVA054](#) for further considerations and the LMR12007 demo board as an example of a four-layer layout.

LMR12007X Circuit Examples

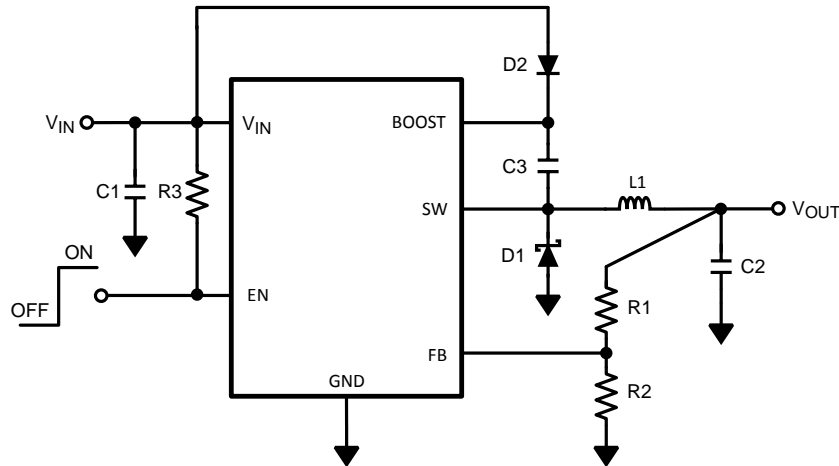

Figure 24. LMR12007X (1.6MHz)
 V_{BOOST} Derived from V_{IN}
 5V to 1.5V/750mA

Table 1. Bill of Materials for Figure 24

Part ID	Part Value	Part Number	Manufacturer
U1	750mA Buck Regulator	LMR12007X	Texas Instruments
C1, Input Cap	10µF, 6.3V, X5R	C3216X5ROJ106M	TDK
C2, Output Cap	10µF, 6.3V, X5R	C3216X5ROJ106M	TDK
C3, Boost Cap	0.01µF, 16V, X7R	C1005X7R1C103K	TDK
D1, Catch Diode	0.3V _F Schottky 1A, 10VR	MBRM110L	ON Semi
D2, Boost Diode	1V _F @ 50mA Diode	1N4148W	Diodes, Inc.
L1	4.7µH, 1.7A,	VLCF4020T- 4R7N1R2	TDK
R1	2kΩ, 1%	CRCW06032001F	Vishay
R2	10kΩ, 1%	CRCW06031002F	Vishay
R3	100kΩ, 1%	CRCW06031003F	Vishay

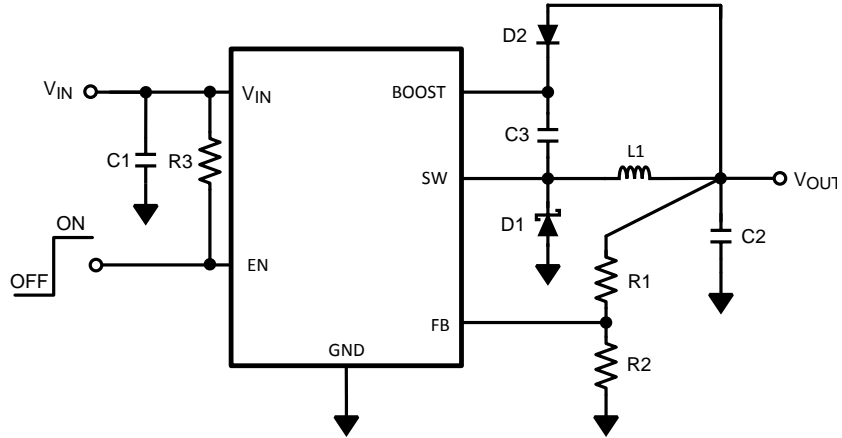

Figure 25. LMR12007X (1.6MHz)
 V_{BOOST} Derived from V_{OUT}
 12V to 3.3V/750mA

Table 2. Bill of Materials for Figure 25

Part ID	Part Value	Part Number	Manufacturer
U1	750mA Buck Regulator	LMR12007X	Texas Instruments
C1, Input Cap	10µF, 25V, X7R	C3225X7R1E106M	TDK
C2, Output Cap	22µF, 6.3V, X5R	C3216X5ROJ226M	TDK
C3, Boost Cap	0.01µF, 16V, X7R	C1005X7R1C103K	TDK
D1, Catch Diode	0.34V _F Schottky 1A, 30VR	SS1P3L	Vishay
D2, Boost Diode	30V, 200 mA Schottky	BAT54	Diodes Inc.
L1	4.7µH, 1.7A,	VLCF4020T- 4R7N1R2	TDK
R1	16.5kΩ, 1%	CRCW06031652F	Vishay
R2	10.0 kΩ, 1%	CRCW06031002F	Vishay
R3	100kΩ, 1%	CRCW06031003F	Vishay

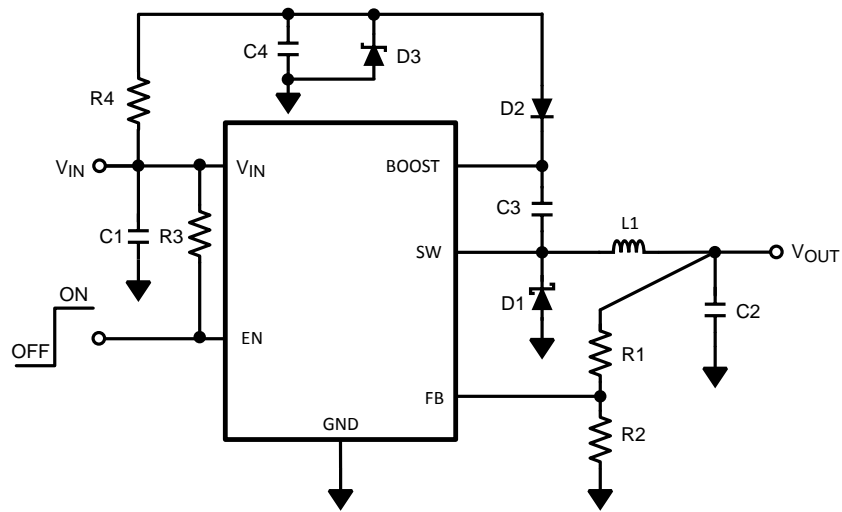

Figure 26. LMR12007X (1.6MHz)
 V_{BOOST} Derived from V_{SHUNT}
 18V to 1.5V/750mA

Table 3. Bill of Materials for Figure 26

Part ID	Part Value	Part Number	Manufacturer
U1	750mA Buck Regulator	LMR12007X	Texas Instruments
C1, Input Cap	10 μ F, 25V, X7R	C3225X7R1E106M	TDK
C2, Output Cap	22 μ F, 6.3V, X5R	C3216X5ROJ226M	TDK
C3, Boost Cap	0.01 μ F, 16V, X7R	C1005X7R1C103K	TDK
C4, Shunt Cap	0.1 μ F, 6.3V, X5R	C1005X5R0J104K	TDK
D1, Catch Diode	0.4V _F Schottky 1A, 30VR	SS1P3L	Vishay
D2, Boost Diode	1V _F @ 50mA Diode	1N4148W	Diodes, Inc.
D3, Zener Diode	5.1V 250Mw SOT	BZX84C5V1	Vishay
L1	6.8 μ H, 1.6A,	SLF7032T-6R8M1R6	TDK
R1	2k Ω , 1%	CRCW06032001F	Vishay
R2	10k Ω , 1%	CRCW06031002F	Vishay
R3	100k Ω , 1%	CRCW06031003F	Vishay
R4	4.12k Ω , 1%	CRCW06034121F	Vishay

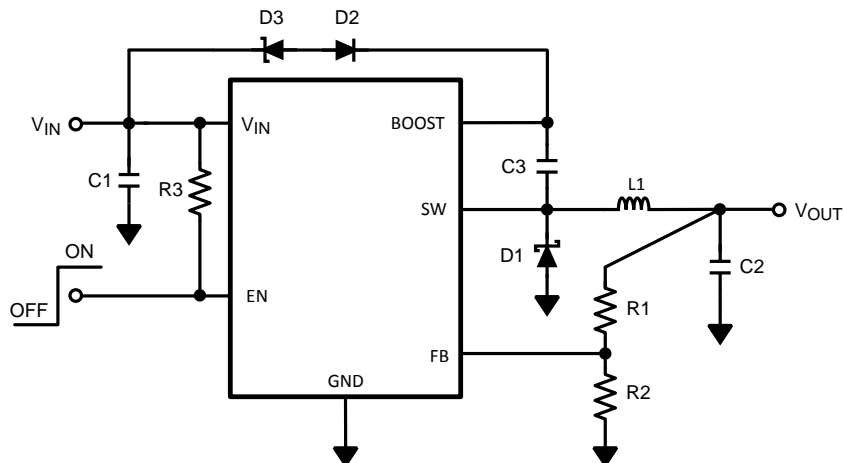

Figure 27. LMR12007X (1.6MHz)
 V_{BOOST} Derived from Series Zener Diode (V_{IN})
 15V to 1.5V/750mA

Table 4. Bill of Materials for Figure 27

Part ID	Part Value	Part Number	Manufacturer
U1	750mA Buck Regulator	LMR12007X	Texas Instruments
C1, Input Cap	10 μ F, 25V, X7R	C3225X7R1E106M	TDK
C2, Output Cap	22 μ F, 6.3V, X5R	C3216X5ROJ226M	TDK
C3, Boost Cap	0.01 μ F, 16V, X7R	C1005X7R1C103K	TDK
D1, Catch Diode	0.4V _F Schottky 1A, 30VR	SS1P3L	Vishay
D2, Boost Diode	1V _F @ 50mA Diode	1N4148W	Diodes, Inc.
D3, Zener Diode	11V 350Mw SOT	BZX84C11T	Diodes, Inc.
L1	6.8 μ H, 1.6A,	SLF7032T-6R8M1R6	TDK
R1	2k Ω , 1%	CRCW06032001F	Vishay
R2	10k Ω , 1%	CRCW06031002F	Vishay
R3	100k Ω , 1%	CRCW06031003F	Vishay

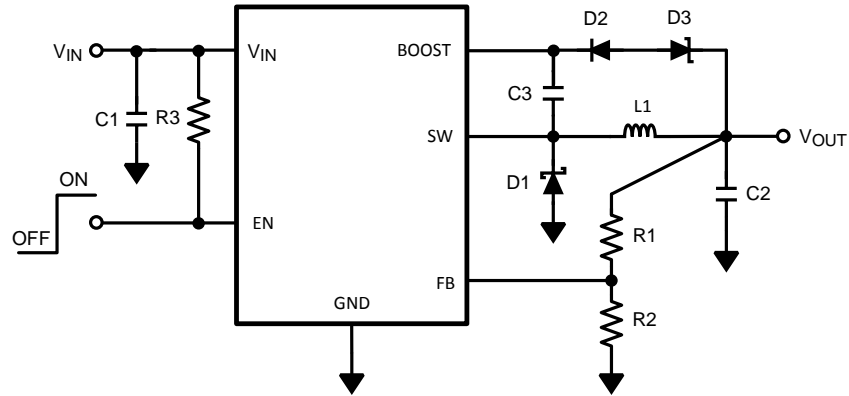

Figure 28. LMR12007X (1.6MHz)
 V_{BOOST} Derived from Series Zener Diode (V_{OUT})
15V to 9V/750mA

Table 5. Bill of Materials for Figure 28

Part ID	Part Value	Part Number	Manufacturer
U1	750mA Buck Regulator	LMR12007X	Texas Instruments
C1, Input Cap	10µF, 25V, X7R	C3225X7R1E106M	TDK
C2, Output Cap	22µF, 16V, X5R	C3216X5R1C226M	TDK
C3, Boost Cap	0.01µF, 16V, X7R	C1005X7R1C103K	TDK
D1, Catch Diode	0.4V _F Schottky 1A, 30VR	SS1P3L	Vishay
D2, Boost Diode	1V _F @ 50mA Diode	1N4148W	Diodes, Inc.
D3, Zener Diode	4.3V 350mw SOT	BZX84C4V3	Diodes, Inc.
L1	6.8µH, 1.6A,	SLF7032T-6R8M1R6	TDK
R1	61.9kΩ, 1%	CRCW06036192F	Vishay
R2	10kΩ, 1%	CRCW06031002F	Vishay
R3	100kΩ, 1%	CRCW06031003F	Vishay

LMR12007Y Circuit Examples

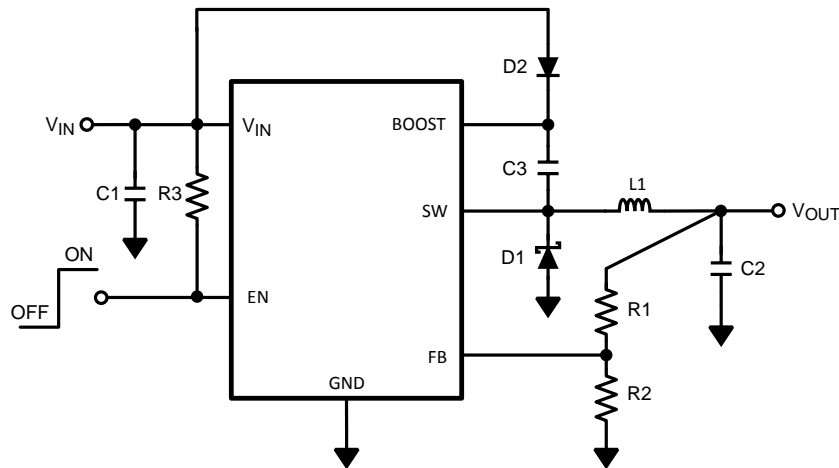

Figure 29. LMR12007Y (550kHz)
 V_{BOOST} Derived from V_{IN}
5V to 1.5V/750mA

Table 6. Bill of Materials for Figure 29

Part ID	Part Value	Part Number	Manufacturer
U1	750mA Buck Regulator	LMR12007Y	Texas Instruments
C1, Input Cap	10µF, 6.3V, X5R	C3216X5ROJ106M	TDK
C2, Output Cap	22µF, 6.3V, X5R	C3216X5ROJ226M	TDK
C3, Boost Cap	0.01µF, 16V, X7R	C1005X7R1C103K	TDK
D1, Catch Diode	0.3V _F Schottky 1A, 10VR	MBRM110L	ON Semi
D2, Boost Diode	1V _F @ 50mA Diode	1N4148W	Diodes, Inc.
L1	10µH, 1.6A,	SLF7032T-100M1R4	TDK
R1	2kΩ, 1%	CRCW06032001F	Vishay
R2	10kΩ, 1%	CRCW06031002F	Vishay
R3	100kΩ, 1%	CRCW06031003F	Vishay

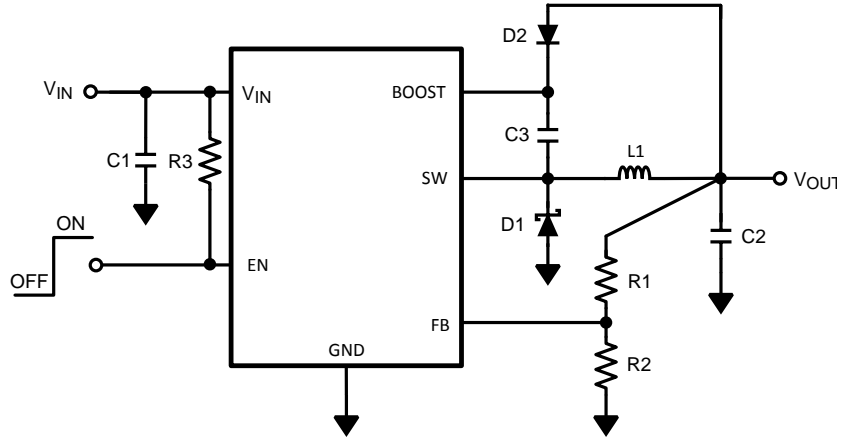

Figure 30. LMR12007Y (550kHz)
 V_{BOOST} Derived from V_{OUT}
 12V to 3.3V/750mA

Table 7. Bill of Materials for Figure 30

Part ID	Part Value	Part Number	Manufacturer
U1	750mA Buck Regulator	LMR12007Y	Texas Instruments
C1, Input Cap	10 μ F, 25V, X7R	C3225X7R1E106M	TDK
C2, Output Cap	22 μ F, 6.3V, X5R	C3216X5ROJ226M	TDK
C3, Boost Cap	0.01 μ F, 16V, X7R	C1005X7R1C103K	TDK
D1, Catch Diode	0.34V _F Schottky 1A, 30VR	SS1P3L	Vishay
D2, Boost Diode	30V, 200 mA Schottky	BAT54	Diodes Inc.
L1	10 μ H, 1.6A,	SLF7032T-100M1R4	TDK
R1	16.5k Ω , 1%	CRCW06031652F	Vishay
R2	10.0 k Ω , 1%	CRCW06031002F	Vishay
R3	100k Ω , 1%	CRCW06031003F	Vishay

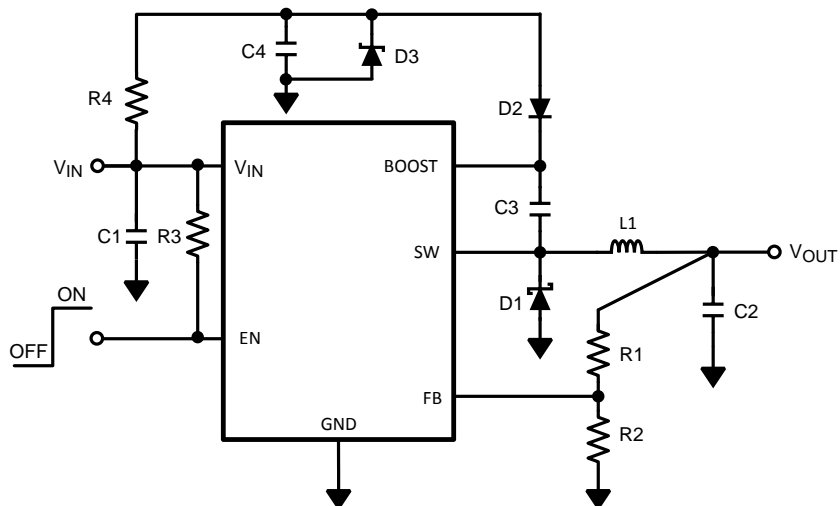
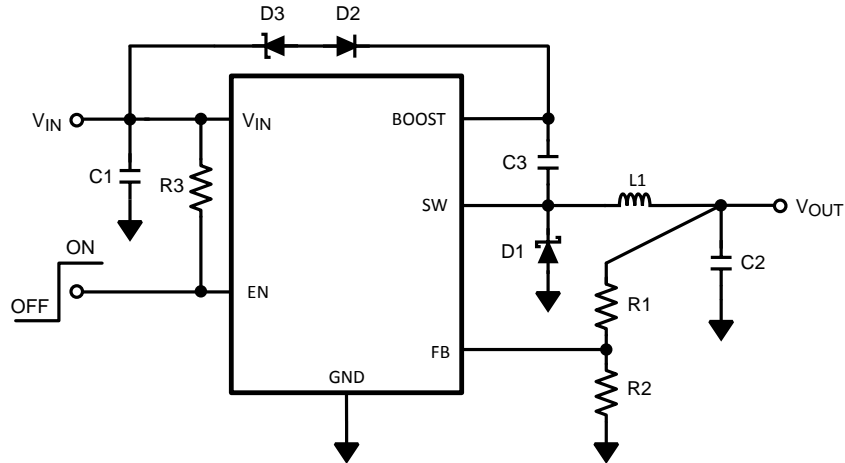

Figure 31. LMR12007Y (550kHz)
 V_{BOOST} Derived from V_{SHUNT}
 18V to 1.5V/750mA

Table 8. Bill of Materials for Figure 31

Part ID	Part Value	Part Number	Manufacturer
U1	750mA Buck Regulator	LMR12007Y	Texas Instruments
C1, Input Cap	10 μ F, 25V, X7R	C3225X7R1E106M	TDK
C2, Output Cap	22 μ F, 6.3V, X5R	C3216X5ROJ226M	TDK
C3, Boost Cap	0.01 μ F, 16V, X7R	C1005X7R1C103K	TDK
C4, Shunt Cap	0.1 μ F, 6.3V, X5R	C1005X5R0J104K	TDK
D1, Catch Diode	0.4V _F Schottky 1A, 30VR	SS1P3L	Vishay
D2, Boost Diode	1V _F @ 50mA Diode	1N4148W	Diodes, Inc.
D3, Zener Diode	5.1V 250Mw SOT	BZX84C5V1	Vishay
L1	15 μ H, 1.5A	SLF7045T-150M1R5	TDK
R1	2k Ω , 1%	CRCW06032001F	Vishay
R2	10k Ω , 1%	CRCW06031002F	Vishay
R3	100k Ω , 1%	CRCW06031003F	Vishay
R4	4.12k Ω , 1%	CRCW06034121F	Vishay



**Figure 32. LMR12007Y (550kHz)
 V_{BOOST} Derived from Series Zener Diode (V_{IN})
 15V to 1.5V/750mA**

Table 9. Bill of Materials for Figure 32

Part ID	Part Value	Part Number	Manufacturer
U1	750mA Buck Regulator	LMR12007Y	Texas Instruments
C1, Input Cap	10µF, 25V, X7R	C3225X7R1E106M	TDK
C2, Output Cap	22µF, 6.3V, X5R	C3216X5ROJ226M	TDK
C3, Boost Cap	0.01µF, 16V, X7R	C1005X7R1C103K	TDK
D1, Catch Diode	0.4V _F Schottky 1A, 30VR	SS1P3L	Vishay
D2, Boost Diode	1V _F @ 50mA Diode	1N4148W	Diodes, Inc.
D3, Zener Diode	11V 350Mw SOT	BZX84C11T	Diodes, Inc.
L1	15µH, 1.5A,	SLF7045T-150M1R5	TDK
R1	2kΩ, 1%	CRCW06032001F	Vishay
R2	10kΩ, 1%	CRCW06031002F	Vishay
R3	100kΩ, 1%	CRCW06031003F	Vishay

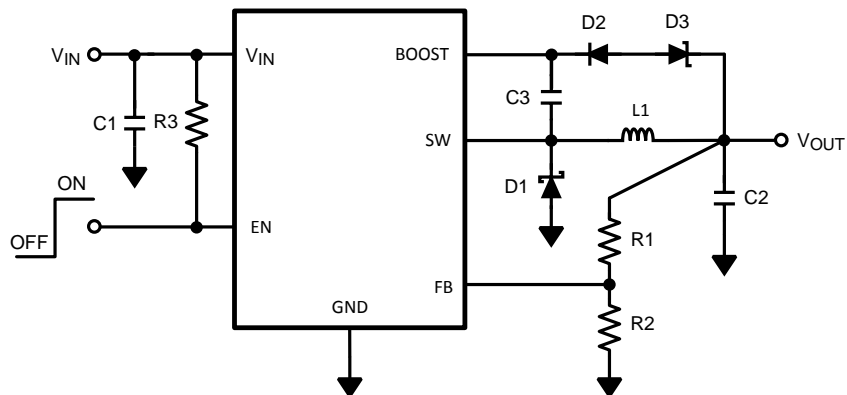

Figure 33. LMR12007Y (550kHz)
 V_{BOOST} Derived from Series Zener Diode (V_{OUT})
 15V to 9V/750mA

Table 10. Bill of Materials for Figure 33

Part ID	Part Value	Part Number	Manufacturer
U1	750mA Buck Regulator	LMR12007Y	Texas Instruments
C1, Input Cap	10µF, 25V, X7R	C3225X7R1E106M	TDK
C2, Output Cap	22µF, 16V, X5R	C3216X5R1C226M	TDK
C3, Boost Cap	0.01µF, 16V, X7R	C1005X7R1C103K	TDK
D1, Catch Diode	0.4V _F Schottky 1A, 30VR	SS1P3L	Vishay
D2, Boost Diode	1V _F @ 50mA Diode	1N4148W	Diodes, Inc.
D3, Zener Diode	4.3V 350mw SOT	BZX84C4V3	Diodes, Inc.
L1	22µH, 1.4A,	SLF7045T-220M1R3-1PF	TDK
R1	61.9kΩ, 1%	CRCW06036192F	Vishay
R2	10kΩ, 1%	CRCW06031002F	Vishay
R3	100kΩ, 1%	CRCW06031003F	Vishay

PACKAGING INFORMATION

Orderable Device	Status (1)	Package Type	Package Drawing	Pins	Package Qty	Eco Plan (2)	Lead finish/ Ball material (6)	MSL Peak Temp (3)	Op Temp (°C)	Device Marking (4/5)	Samples
LMR12007XMK	ACTIVE	SOT-23-THIN	DDC	6	1000	RoHS & Green	SN	Level-1-260C-UNLIM	-40 to 125	SP1B	Samples
LMR12007XMKX	ACTIVE	SOT-23-THIN	DDC	6	3000	RoHS & Green	SN	Level-1-260C-UNLIM	-40 to 125	SP1B	Samples
LMR12007YMK	ACTIVE	SOT-23-THIN	DDC	6	1000	RoHS & Green	SN	Level-1-260C-UNLIM	-40 to 125	SP2B	Samples
LMR12007YMKX	ACTIVE	SOT-23-THIN	DDC	6	3000	RoHS & Green	SN	Level-1-260C-UNLIM	-40 to 125	SP2B	Samples

(1) The marketing status values are defined as follows:

ACTIVE: Product device recommended for new designs.

LIFEBUY: TI has announced that the device will be discontinued, and a lifetime-buy period is in effect.

NRND: Not recommended for new designs. Device is in production to support existing customers, but TI does not recommend using this part in a new design.

PREVIEW: Device has been announced but is not in production. Samples may or may not be available.

OBSELETE: TI has discontinued the production of the device.

(2) **RoHS:** TI defines "RoHS" to mean semiconductor products that are compliant with the current EU RoHS requirements for all 10 RoHS substances, including the requirement that RoHS substance do not exceed 0.1% by weight in homogeneous materials. Where designed to be soldered at high temperatures, "RoHS" products are suitable for use in specified lead-free processes. TI may reference these types of products as "Pb-Free".

RoHS Exempt: TI defines "RoHS Exempt" to mean products that contain lead but are compliant with EU RoHS pursuant to a specific EU RoHS exemption.

Green: TI defines "Green" to mean the content of Chlorine (Cl) and Bromine (Br) based flame retardants meet JS709B low halogen requirements of <=1000ppm threshold. Antimony trioxide based flame retardants must also meet the <=1000ppm threshold requirement.

(3) **MSL, Peak Temp.** - The Moisture Sensitivity Level rating according to the JEDEC industry standard classifications, and peak solder temperature.

(4) There may be additional marking, which relates to the logo, the lot trace code information, or the environmental category on the device.

(5) Multiple Device Markings will be inside parentheses. Only one Device Marking contained in parentheses and separated by a "-" will appear on a device. If a line is indented then it is a continuation of the previous line and the two combined represent the entire Device Marking for that device.

(6) **Lead finish/Ball material** - Orderable Devices may have multiple material finish options. Finish options are separated by a vertical ruled line. Lead finish/Ball material values may wrap to two lines if the finish value exceeds the maximum column width.

Important Information and Disclaimer:The information provided on this page represents TI's knowledge and belief as of the date that it is provided. TI bases its knowledge and belief on information provided by third parties, and makes no representation or warranty as to the accuracy of such information. Efforts are underway to better integrate information from third parties. TI has taken and

continues to take reasonable steps to provide representative and accurate information but may not have conducted destructive testing or chemical analysis on incoming materials and chemicals. TI and TI suppliers consider certain information to be proprietary, and thus CAS numbers and other limited information may not be available for release.

In no event shall TI's liability arising out of such information exceed the total purchase price of the TI part(s) at issue in this document sold by TI to Customer on an annual basis.

TAPE AND REEL INFORMATION



QUADRANT ASSIGNMENTS FOR PIN 1 ORIENTATION IN TAPE



*All dimensions are nominal

Device	Package Type	Package Drawing	Pins	SPQ	Reel Diameter (mm)	Reel Width W1 (mm)	A0 (mm)	B0 (mm)	K0 (mm)	P1 (mm)	W (mm)	Pin1 Quadrant
LMR12007XMK	SOT-23-THIN	DDC	6	1000	178.0	8.4	3.2	3.2	1.4	4.0	8.0	Q3
LMR12007XMKX	SOT-23-THIN	DDC	6	3000	178.0	8.4	3.2	3.2	1.4	4.0	8.0	Q3
LMR12007YMK	SOT-23-THIN	DDC	6	1000	178.0	8.4	3.2	3.2	1.4	4.0	8.0	Q3
LMR12007YMKX	SOT-23-THIN	DDC	6	3000	178.0	8.4	3.2	3.2	1.4	4.0	8.0	Q3

TAPE AND REEL BOX DIMENSIONS

*All dimensions are nominal

Device	Package Type	Package Drawing	Pins	SPQ	Length (mm)	Width (mm)	Height (mm)
LMR12007XMK	SOT-23-THIN	DDC	6	1000	208.0	191.0	35.0
LMR12007XMKX	SOT-23-THIN	DDC	6	3000	208.0	191.0	35.0
LMR12007YMK	SOT-23-THIN	DDC	6	1000	208.0	191.0	35.0
LMR12007YMKX	SOT-23-THIN	DDC	6	3000	208.0	191.0	35.0

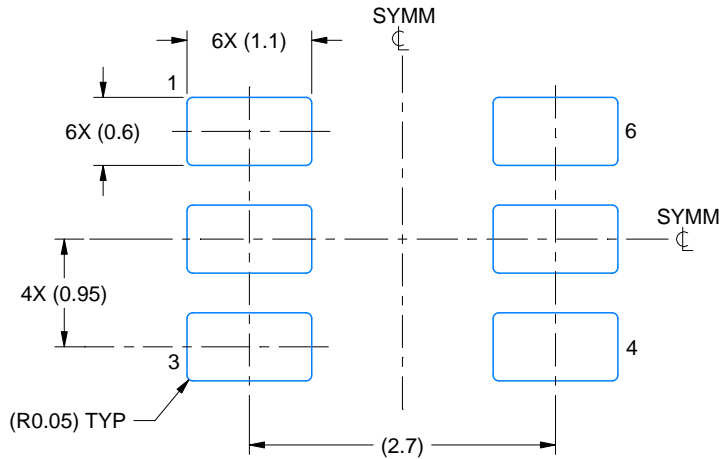

LAND PATTERN EXAMPLE
EXPLODED METAL SHOWN
SCALE:15X



SOLDEMASK DETAILS

4214841/C 04/2022

NOTES: (continued)

- 4. Publication IPC-7351 may have alternate designs.
- 5. Solder mask tolerances between and around signal pads can vary based on board fabrication site.

EXAMPLE STENCIL DESIGN

DDC0006A

SOT-23 - 1.1 max height

SMALL OUTLINE TRANSISTOR

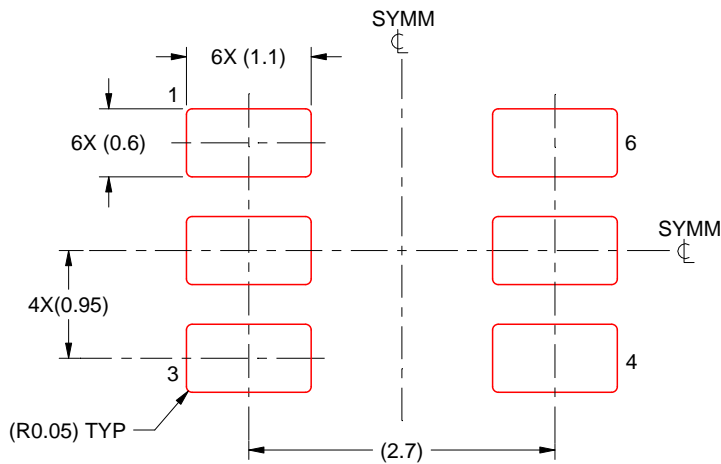

SOLDER PASTE EXAMPLE
BASED ON 0.125 THICK STENCIL
SCALE:15X

4214841/C 04/2022

NOTES: (continued)

6. Laser cutting apertures with trapezoidal walls and rounded corners may offer better paste release. IPC-7525 may have alternate design recommendations.
7. Board assembly site may have different recommendations for stencil design.

IMPORTANT NOTICE AND DISCLAIMER

TI PROVIDES TECHNICAL AND RELIABILITY DATA (INCLUDING DATA SHEETS), DESIGN RESOURCES (INCLUDING REFERENCE DESIGNS), APPLICATION OR OTHER DESIGN ADVICE, WEB TOOLS, SAFETY INFORMATION, AND OTHER RESOURCES "AS IS" AND WITH ALL FAULTS, AND DISCLAIMS ALL WARRANTIES, EXPRESS AND IMPLIED, INCLUDING WITHOUT LIMITATION ANY IMPLIED WARRANTIES OF MERCHANTABILITY, FITNESS FOR A PARTICULAR PURPOSE OR NON-INFRINGEMENT OF THIRD PARTY INTELLECTUAL PROPERTY RIGHTS.

These resources are intended for skilled developers designing with TI products. You are solely responsible for (1) selecting the appropriate TI products for your application, (2) designing, validating and testing your application, and (3) ensuring your application meets applicable standards, and any other safety, security, regulatory or other requirements.

These resources are subject to change without notice. TI grants you permission to use these resources only for development of an application that uses the TI products described in the resource. Other reproduction and display of these resources is prohibited. No license is granted to any other TI intellectual property right or to any third party intellectual property right. TI disclaims responsibility for, and you will fully indemnify TI and its representatives against, any claims, damages, costs, losses, and liabilities arising out of your use of these resources.

TI's products are provided subject to [TI's Terms of Sale](#) or other applicable terms available either on [ti.com](https://www.ti.com) or provided in conjunction with such TI products. TI's provision of these resources does not expand or otherwise alter TI's applicable warranties or warranty disclaimers for TI products.

TI objects to and rejects any additional or different terms you may have proposed.

Mailing Address: Texas Instruments, Post Office Box 655303, Dallas, Texas 75265
Copyright © 2023, Texas Instruments Incorporated