

Dual 1.5 Gbps 2:1/1:2 LVDS Mux/Buffer with Pre-Emphasis and IEEE 1149.6

Check for Samples: [SCAN15MB200](#)

FEATURES

- 1.5 Gbps Data Rate Per Channel
- Configurable Off/On Pre-emphasis Drives Lossy Backplanes and Cables
- LVDS/BLVDS/CML/LVPECL Compatible Inputs, LVDS Compatible Outputs
- Low Output Skew and Jitter
- On-chip 100Ω Input and Output Termination
- IEEE 1149.1 and 1149.6 Compliant
- 15 kV ESD Protection on LVDS Inputs/Outputs
- Hot Plug Protection
- Single 3.3V Supply
- Industrial -40 to +85°C Temperature Range
- 48-Pin WQFN Package

DESCRIPTION

The SCAN15MB200 is a dual-port 2 to 1 multiplexer and 1 to 2 repeater/buffer. High-speed data paths and flow-through pinout minimize internal device jitter and simplify board layout, while pre-emphasis overcomes ISI jitter effects from lossy backplanes and cables. The differential inputs and outputs interface to LVDS or Bus LVDS signals such as those on TI's 10-, 16-, and 18-bit Bus LVDS SerDes, or to CML or LVPECL signals.

Integrated IEEE 1149.1 (JTAG) and 1149.6 circuitry supports testability of both single-ended LVTTTL/CMOS and high-speed differential PCB interconnects. The 3.3V supply, CMOS process, and robust I/O ensure high performance at low power over the entire industrial -40 to +85°C temperature range.

Typical Application

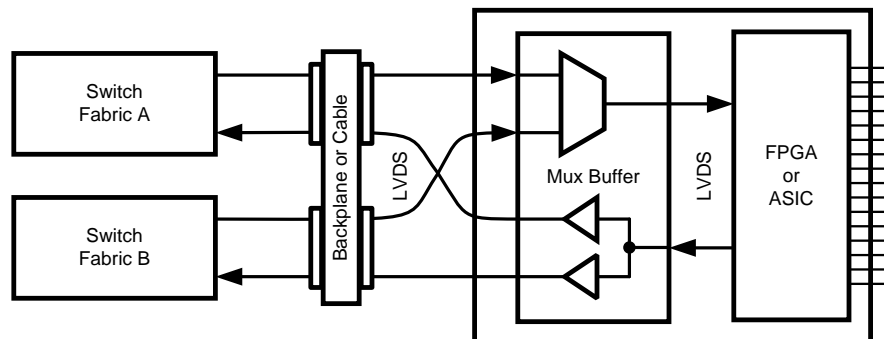

Please be aware that an important notice concerning availability, standard warranty, and use in critical applications of Texas Instruments semiconductor products and disclaimers thereto appears at the end of this data sheet.

All trademarks are the property of their respective owners.

Block Diagram

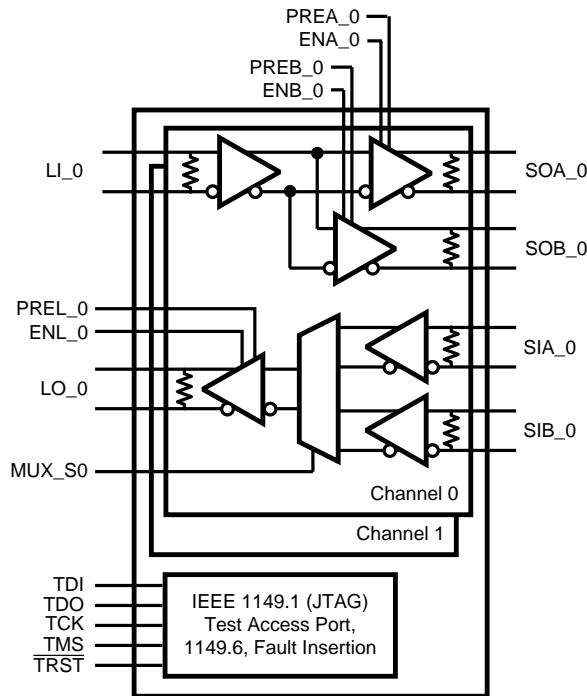

Figure 1. SCAN15MB200 Block Diagram

Pin Descriptions

Pin Name	WQFN Pin Number	I/O, Type	Description
SWITCH SIDE DIFFERENTIAL INPUTS			
SIA_0+ SIA_0-	30 29	I, LVDS	Switch A-side Channel 0 inverting and non-inverting differential inputs. LVDS, Bus LVDS, CML, or LVPECL compatible.
SIA_1+ SIA_1-	19 20	I, LVDS	Switch A-side Channel 1 inverting and non-inverting differential inputs. LVDS, Bus LVDS, CML, or LVPECL compatible.
SIB_0+ SIB_0-	28 27	I, LVDS	Switch B-side Channel 0 inverting and non-inverting differential inputs. LVDS, Bus LVDS, CML, or LVPECL compatible.
SIB_1+ SIB_1-	21 22	I, LVDS	Switch B-side Channel 1 inverting and non-inverting differential inputs. LVDS, Bus LVDS, CML, or LVPECL compatible.
LINE SIDE DIFFERENTIAL INPUTS			
LI_0+ LI_0-	40 39	I, LVDS	Line-side Channel 0 inverting and non-inverting differential inputs. LVDS, Bus LVDS, CML, or LVPECL compatible.
LI_1+ LI_1-	9 10	I, LVDS	Line-side Channel 1 inverting and non-inverting differential inputs. LVDS, Bus LVDS, CML, or LVPECL compatible.
SWITCH SIDE DIFFERENTIAL OUTPUTS			
SOA_0+ SOA_0-	34 33	O, LVDS	Switch A-side Channel 0 inverting and non-inverting differential outputs. LVDS compatible ⁽¹⁾ ⁽²⁾ .
SOA_1+ SOA_1-	15 16	O, LVDS	Switch A-side Channel 1 inverting and non-inverting differential outputs. LVDS compatible ⁽¹⁾ ⁽²⁾ .
SOB_0+ SOB_0-	32 31	O, LVDS	Switch B-side Channel 0 inverting and non-inverting differential outputs. LVDS compatible ⁽¹⁾ ⁽²⁾ .
SOB_1+ SOB_1-	17 18	O, LVDS	Switch B-side Channel 1 inverting and non-inverting differential outputs. LVDS compatible ⁽¹⁾ ⁽²⁾ .

(1) For interfacing LVDS outputs to CML or LVPECL compatible inputs, refer to the [applications](#) section of this datasheet (planned).
 (2) The LVDS outputs do not support a multidrop (BLVDS) environment. The LVDS output characteristics of the SCAN15MB200 device have been optimized for point-to-point backplane and cable applications.

Pin Descriptions (continued)

Pin Name	WQFN Pin Number	I/O, Type	Description
LINE SIDE DIFFERENTIAL OUTPUTS			
LO_0+ LO_0-	42 41	O, LVDS	Line-side Channel 0 inverting and non-inverting differential outputs. LVDS compatible ⁽³⁾ ⁽⁴⁾ .
LO_1+ LO_1-	7 8	O, LVDS	Line-side Channel 1 inverting and non-inverting differential outputs. LVDS compatible ⁽³⁾ ⁽⁴⁾ .
DIGITAL CONTROL INTERFACE			
MUX_S0 MUX_S1	38 11	I, LVTTTL	Mux Select Control Inputs (per channel) to select which Switch-side input, A or B, is passed through to the Line-side.
PREA_0 PREA_1 PREB_0 PREB_1	26 23 25 24	I, LVTTTL	Output pre-emphasis control for Switch-side outputs. Each output driver on the Switch A-side and B-side has a separate pin to control the pre-emphasis on or off.
PREL_0 PREL_1	44 5	I, LVTTTL	Output pre-emphasis control for Line-side outputs. Each output driver on the Line A-side and B-side has a separate pin to control the pre-emphasis on or off.
ENA_0 ENA_1 ENB_0 ENB_1	36 13 35 14	I, LVTTTL	Output Enable Control for Switch A-side and B-side outputs. Each output driver on the A-side and B-side has a separate enable pin.
ENL_0 ENL_1	45 4	I, LVTTTL	Output Enable Control for The Line-side outputs. Each output driver on the Line-side has a separate enable pin.
TDI	2	I, LVTTTL	Test Data Input to support IEEE 1149.1 features
TDO	1	O, LVTTTL	Test Data Output to support IEEE 1149.1 features
TMS	46	I, LVTTTL	Test Mode Select to support IEEE 1149.1 features
TCK	47	I, LVTTTL	Test Clock to support IEEE 1149.1 features
TRST	3	I, LVTTTL	Test Reset to support IEEE 1149.1 features
POWER			
V _{DD}	6, 12, 37, 43, 48	I, Power	V _{DD} = 3.3V ±0.3V.
GND	See ⁽⁵⁾	I, Power	Ground reference for LVDS and CMOS circuitry. For the WQFN package, the DAP is used as the primary GND connection to the device. The DAP is the exposed metal contact at the bottom of the WQFN-48 package. It should be connected to the ground plane with at least 4 vias for optimal AC and thermal performance.

(3) For interfacing LVDS outputs to CML or LVPECL compatible inputs, refer to the [applications](#) section of this datasheet (planned).

(4) The LVDS outputs do not support a multidrop (BLVDS) environment. The LVDS output characteristics of the SCAN15MB200 device have been optimized for point-to-point backplane and cable applications.

(5) Note that the DAP on the backside of the WQFN package is the primary GND connection for the device when using the WQFN package.

Connection Diagram

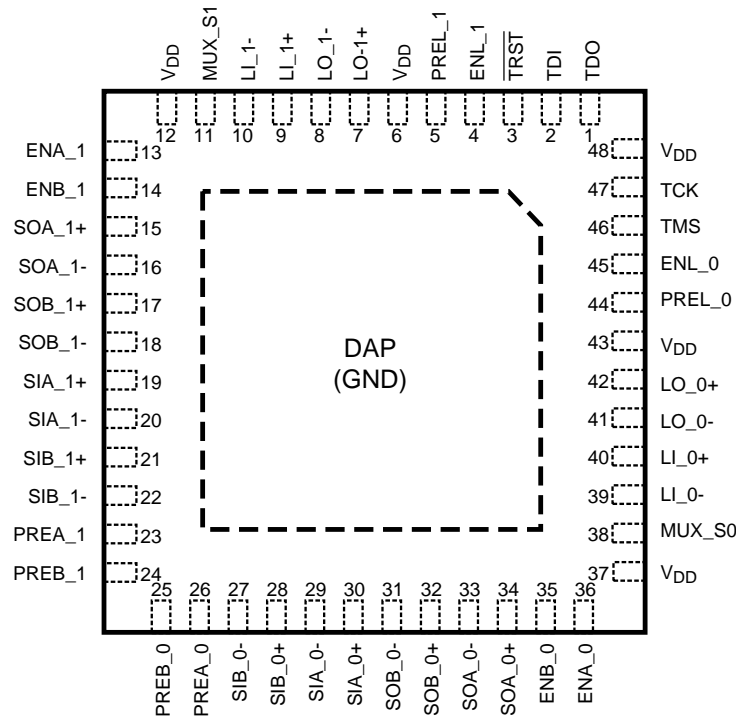

WQFN Top View
DAP = GND

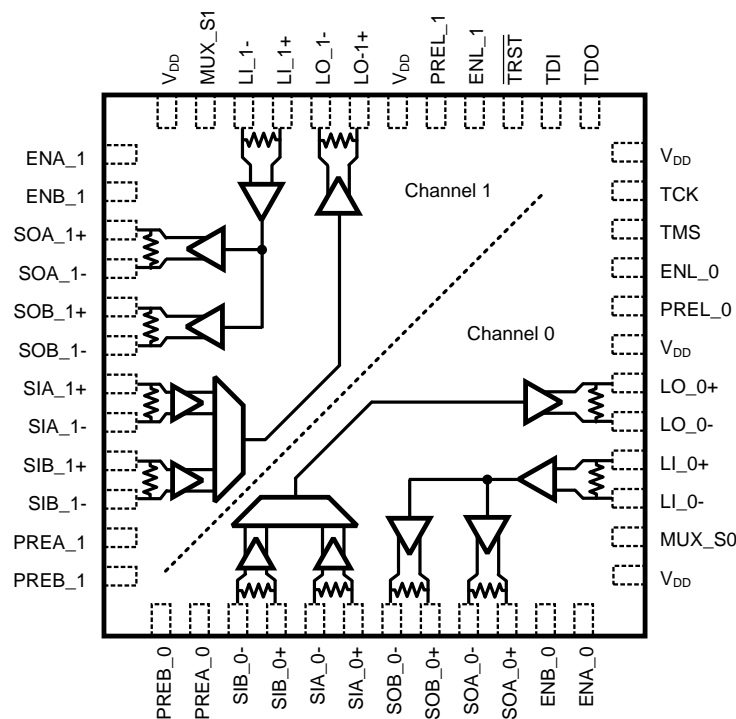

Directional Signal Paths Top View
(Refer to pin names for signal polarity)

OUTPUT CHARACTERISTICS

The output characteristics of the SCAN15MB200 have been optimized for point-to-point backplane and cable applications, and are not intended for multipoint or multidrop signaling.

A 100Ω output (source) termination resistor is incorporated in the device to eliminate the need for an external resistor, providing excellent drive characteristics by locating the source termination as close to the output as physically possible.

Pre-Emphasis Controls

The pre-emphasis is used to compensate for long or lossy transmission media. Separate pins are provided for each output to minimize power consumption. Pre-emphasis is programmable to be off or on per the Pre-emphasis Control Table.

PREx_n ⁽¹⁾	Output Pre-emphasis
0	0%
1	100%

(1) Applies to PREA_0, PREA_1, PREB_0, PREB_1, PREL_0, PREL_1

Multiplexer Truth Table ⁽¹⁾⁽²⁾

Data Inputs		Control Inputs		Output
SIA_0	SIB_0	MUX_S0	ENL_0	LO_0
X	valid	0	1	SIB_0
valid	X	1	1	SIA_0
X	X	X	0 ⁽³⁾	Z

- (1) Same functionality for channel 1
- (2) X = Don't Care
Z = High Impedance (TRI-STATE)
- (3) When all enable inputs from both channels are Low, the device enters a powerdown mode. Refer to the applications section titled [TRI-STATE and Powerdown Modes](#).

Repeater/Buffer Truth Table ⁽¹⁾⁽²⁾

Data Input	Control Inputs		Outputs	
LI_0	ENA_0	ENB_0	SOA_0	SOB_0
X	0	0	Z ⁽³⁾	Z ⁽³⁾
valid	0	1	Z	LI_0
valid	1	0	LI_0	Z
valid	1	1	LI_0	LI_0

- (1) Same functionality for channel 1
- (2) X = Don't Care
Z = High Impedance (TRI-STATE)
- (3) When all enable inputs from both channels are Low, the device enters a powerdown mode. Refer to the applications section titled [TRI-STATE and Powerdown Modes](#).



These devices have limited built-in ESD protection. The leads should be shorted together or the device placed in conductive foam during storage or handling to prevent electrostatic damage to the MOS gates.

Absolute Maximum Ratings ⁽¹⁾

		Value	Unit
Supply Voltage (V_{DD})		-0.3V to +4.0	V
CMOS Input Voltage		-0.3V to ($V_{DD}+0.3$)	V
LVDS Receiver Input Voltage ⁽²⁾		-0.3V to ($V_{DD}+0.3$)	V
LVDS Driver Output Voltage		-0.3V to ($V_{DD}+0.3$)	V
LVDS Output Short Circuit Current		+40	mA
Junction Temperature		+150	°C
Storage Temperature		-65°C to +150	°C
Lead Temperature (Solder, 4sec)		260	°C
Max Pkg Power Capacity @ 25°C		5.2	W
Thermal Resistance (θ_{JA})		24	°C/W
Package Derating above +25°C		41.7	mW/°C
ESD Last Passing Voltage	HBM, 1.5k Ω , 100pF	8	kV
	LVDS pins to GND only	15	kV
	EIAJ, 0 Ω , 200pF	250	V
	CDM	1000	V

- (1) Absolute maximum ratings are those values beyond which damage to the device may occur. The databook specifications should be met, without exception, to ensure that the system design is reliable over its power supply, temperature, and output/input loading variables. TI does not recommend operation of products outside of recommended operation conditions.
- (2) V_{ID} max < 2.4V

Recommended Operating Conditions

	Min	Max	Unit
Supply Voltage (V_{CC})	3.0	3.6	V
Input Voltage (V_I) ⁽¹⁾	0	V_{CC}	V
Output Voltage (V_O)	0	V_{CC}	V
Operating Temperature (T_A) Industrial	-40	+85	°C

- (1) V_{ID} max < 2.4V

Electrical Characteristics

Over recommended operating supply and temperature ranges unless other specified.

Symbol	Parameter	Conditions	Min	Typ ⁽¹⁾	Max	Units
LVTTL DC SPECIFICATIONS (MUX_Sn, PREA_n, PREB_n, PREL_n, ENA_n, ENB_n, ENL_n, TDI, TDO, TCK, TMS, \overline{TRST})						
V_{IH}	High Level Input Voltage		2.0		V_{DD}	V
V_{IL}	Low Level Input Voltage		GND		0.8	V
I_{IH}	High Level Input Current	$V_{IN} = V_{DD} = V_{DDMAX}$	-10		+10	μ A
I_{IHR}	High Level Output Current	PREA_n, PREB_n, PREL_n	40		200	μ A
I_{IL}	Low Level Input Current	$V_{IN} = V_{SS}, V_{DD} = V_{DDMAX}$	-10		+10	μ A
I_{ILR}	Low Level Input Current	TDI, TMS, \overline{TRST}	-40		-200	μ A
C_{IN1}	Input Capacitance	Any Digital Input Pin to V_{SS}		2.0		pF
C_{OUT1}	Output Capacitance	Any Digital Output Pin to V_{SS}		4.0		pF
V_{CL}	Input Clamp Voltage	$I_{CL} = -18$ mA	-1.5	-0.8		V
V_{OH}	High Level Output Voltage (TDO)	$I_{OH} = -12$ mA, $V_{DD} = 3.0$ V	2.4			V
		$I_{OH} = -100$ μ A, $V_{DD} = 3.0$ V	$V_{DD}-0.2$			V
V_{OL}	Low Level Output Voltage (TDO)	$I_{OL} = 12$ mA, $V_{DD} = 3.0$ V			0.5	V
		$I_{OL} = 100$ μ A, $V_{DD} = 3.0$ V			0.2	V
I_{OS}	Output Short Circuit Current	TDO	-15		-125	mA
I_{OZ}	Output TRI-STATE Current	TDO	-10		+10	μ A

- (1) Typical parameters are measured at $V_{DD} = 3.3$ V, $T_A = 25$ °C. They are for reference purposes, and are not production-tested.

Electrical Characteristics (continued)

Over recommended operating supply and temperature ranges unless other specified.

Symbol	Parameter	Conditions	Min	Typ ⁽¹⁾	Max	Units
LVDS INPUT DC SPECIFICATIONS (SIA_±, SIB_±, LI_±)						
V _{TH}	Differential Input High Threshold ⁽²⁾	V _{CM} = 0.8V or 1.2V or 3.55V, V _{DD} = 3.6V		0	100	mV
V _{TL}	Differential Input Low Threshold ⁽²⁾	V _{CM} = 0.8V or 1.2V or 3.55V, V _{DD} = 3.6V	-100	0		mV
V _{ID}	Differential Input Voltage	V _{CM} = 0.8V to 3.55V, V _{DD} = 3.6V	100		2400	mV
V _{CMR}	Common Mode Voltage Range	V _{ID} = 150 mV, V _{DD} = 3.6V	0.05		3.55	V
C _{IN2}	Input Capacitance	IN+ or IN- to V _{SS}		2.0		pF
I _{IN}	Input Current	V _{IN} = 3.6V, V _{DD} = V _{DDMAX} or 0V	-15		+15	μA
		V _{IN} = 0V, V _{DD} = V _{DDMAX} or 0V	-15		+15	μA
LVDS OUTPUT DC SPECIFICATIONS (SOA_{n±}, SOB_{n±}, LO_{n±})						
V _{OD}	Differential Output Voltage, 0% Pre-emphasis ⁽²⁾	R _L is the internal 100Ω between OUT+ and OUT-	250	360	500	mV
ΔV _{OD}	Change in V _{OD} between Complementary States		-35		35	mV
V _{OS}	Offset Voltage ⁽³⁾		1.05	1.22	1.475	V
ΔV _{OS}	Change in V _{OS} between Complementary States		-35		35	mV
I _{OS}	Output Short Circuit Current	OUT+ or OUT- Short to GND		-21	-40	mA
C _{OUT2}	Output Capacitance	OUT+ or OUT- to GND when TRI- STATE		4.0		pF
SUPPLY CURRENT (Static)						
I _{CC}	Supply Current	All inputs and outputs enabled and active, terminated with differential load of 100Ω between OUT+ and OUT-		225	275	mA
I _{CCZ}	Supply Current - Powerdown Mode	ENA_0 = ENB_0 = ENL_0 = ENA_1 = ENB_1 = ENL_1 = L		0.6	4.0	mA
SWITCHING CHARACTERISTICS—LVDS OUTPUTS						
t _{LHT}	Differential Low to High Transition Time	Use an alternating 1 and 0 pattern at 200 Mb/s, measure between 20% and 80% of V _{OD} . ⁽⁴⁾		170	250	ps
t _{HHT}	Differential High to Low Transition Time			170	250	ps
t _{PLHD}	Differential Low to High Propagation Delay	Use an alternating 1 and 0 pattern at 200 Mb/s, measure at 50% V _{OD} between input to output.		1.0	2.5	ns
t _{PHLD}	Differential High to Low Propagation Delay			1.0	2.5	ns
t _{SKD1}	Pulse Skew	t _{PLHD} - t _{PHLD} ⁽⁴⁾		25	75	ps
t _{SKCC}	Output Channel to Channel Skew	Difference in propagation delay (t _{PLHD} or t _{PHLD}) among all output channels. ⁽⁴⁾		50	115	ps
t _{JIT}	Jitter (0% Pre-emphasis) ⁽⁵⁾	RJ - Alternating 1 and 0 at 750MHz ⁽⁶⁾		1.1	1.5	psrms
		DJ - K28.5 Pattern, 1.5 Gbps ⁽⁷⁾		20	34	psp-p
		TJ - PRBS 2 ⁷ -1 Pattern, 1.5 Gbps ⁽⁸⁾		14	28	psp-p

(2) Differential output voltage V_{OD} is defined as ABS(OUT+–OUT–). Differential input voltage V_{ID} is defined as ABS(IN+–IN–).

(3) Output offset voltage V_{OS} is defined as the average of the LVDS single-ended output voltages at logic high and logic low states.

(4) Not Production tested. Specified by statistical analysis on a sample basis at the time of characterization.

(5) Jitter is not production tested, but specified through characterization on a sample basis.

(6) Random Jitter, or RJ, is measured RMS with a histogram including 1500 histogram window hits. The input voltage = V_{ID} = 500mV, 50% duty cycle at 750MHz, t_r = t_f = 50ps (20% to 80%).

(7) Deterministic Jitter, or DJ, is measured to a histogram mean with a sample size of 350 hits. Stimulus and fixture jitter has been subtracted. The input voltage = V_{ID} = 500mV, K28.5 pattern at 1.5 Gbps, t_r = t_f = 50ps (20% to 80%). The K28.5 pattern is repeating bit streams of (0011111010 1100000101).

(8) Total Jitter, or TJ, is measured peak to peak with a histogram including 3500 window hits. Stimulus and fixture jitter has been subtracted. The input voltage = V_{ID} = 500mV, 2⁷-1 PRBS pattern at 1.5 Gbps, t_r = t_f = 50ps (20% to 80%).

Electrical Characteristics (continued)

Over recommended operating supply and temperature ranges unless other specified.

Symbol	Parameter	Conditions	Min	Typ ⁽¹⁾	Max	Units
t_{ON}	LVDS Output Enable Time	Time from ENA_n, ENB_n, or ENL_n to OUT \pm change from TRI-STATE to active.		0.5	1.5	μ s
t_{ON2}	LVDS Output Enable time from powerdown mode	Time from ENA_n, ENB_n, or ENL_n to OUT \pm change from Powerdown to active		10	20	μ s
t_{OFF}	LVDS Output Disable Time	Time from ENA_n, ENB_n, or ENL_n to OUT \pm change from active to TRI-STATE or powerdown.			12	ns
SWITCHING CHARACTERISTICS - SCAN FEATURES						
f_{MAX}	Maximum TCK Clock Frequency	$R_L = 500\Omega$, $C_L = 35\text{ pF}$	25.0			MHz
t_S	TDI to TCK, H or L		3.0			ns
t_H	TDI to TCK, H or L		0.5			ns
t_S	TMS to TCK, H or L		3.0			ns
t_H	TMS to TCK, H or L		0.5			ns
t_W	TCK Pulse Width, H or L		10.0			ns
t_W	$\overline{\text{TRST}}$ Pulse Width, L		2.5			ns
t_{REC}	Recovery Time, $\overline{\text{TRST}}$ to TCK		2.0			ns

Typical Performance Characteristics

WQFN Performance Characteristics

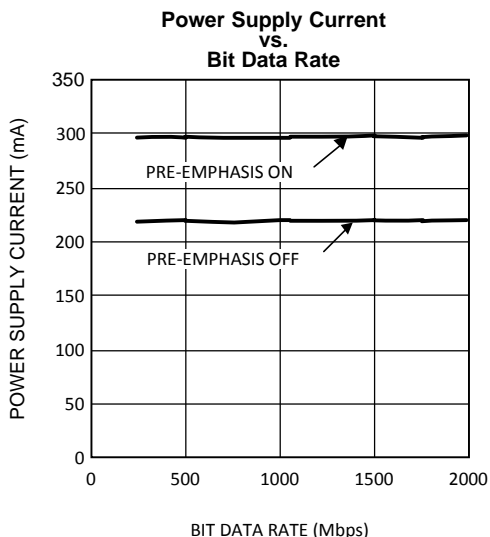

BIT DATA RATE (Mbps)

Dynamic power supply current was measured with all channels active and toggling at the bit data rate. Data pattern has no effect on the power consumption. $V_{DD} = 3.3V$, $T_A = +25^{\circ}C$, $V_{ID} = 0.5V$, $V_{CM} = 1.2V$

Figure 2.

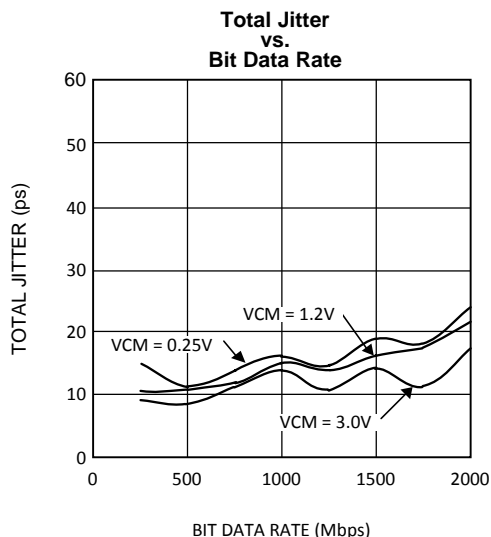

BIT DATA RATE (Mbps)

Total Jitter measured at 0V differential while running a PRBS 2^{7-1} pattern with one channel active, all other channels are disabled. $V_{DD} = 3.3V$, $T_A = +25^{\circ}C$, $V_{ID} = 0.5V$, pre-emphasis off.

Figure 3.

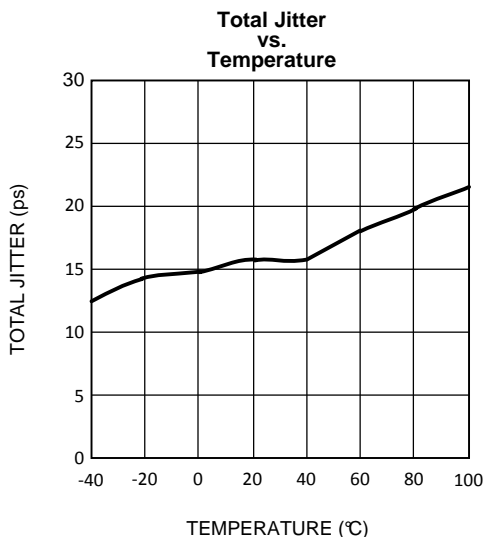

TEMPERATURE (°C)

Total Jitter measured at 0V differential while running a PRBS 2^{7-1} pattern with one channel active, all other channels are disabled. $V_{DD} = 3.3V$, $V_{ID} = 0.5V$, $V_{CM} = 1.2V$, 1.5 Gbps data rate, pre-emphasis off.

Figure 4.

TRI-STATE AND POWERDOWN MODES

The SCAN15MB200 has output enable control on each of the six onboard LVDS output drivers. This control allows each output individually to be placed in a low power TRI-STATE mode while the device remains active, and is useful to reduce power consumption on unused channels. In TRI-STATE mode, some outputs may remain active while some are in TRI-STATE.

When all six of the output enables (all drivers on both channels) are deasserted (LOW), then the device enters a Powerdown mode that consumes only 0.5mA (typical) of supply current. In this mode, the entire device is essentially powered off, including all receiver inputs, output drivers and internal bandgap reference generators. When returning to active mode from Powerdown mode, there is a delay until valid data is presented at the outputs because of the ramp to power up the internal bandgap reference generators.

Any single output enable that remains active will hold the device in active mode even if the other five outputs are in TRI-STATE.

When in Powerdown mode, any output enable that becomes active will wake up the device back into active mode, even if the other five outputs are in TRI-STATE.

Input Failsafe Biasing

External pull up and pull down resistors may be used to provide enough of an offset to enable an input failsafe under open-circuit conditions. This configuration ties the positive LVDS input pin to VDD thru a pull up resistor and the negative LVDS input pin is tied to GND by a pull down resistor. The pull up and pull down resistors should be in the 5k Ω to 15k Ω range to minimize loading and waveform distortion to the driver. Please refer to application note AN-1194 (SNLA051), "Failsafe Biasing of LVDS Interfaces" for more information.

Interfacing LVPECL to LVDS

An LVPECL driver consists of a differential pair with coupled emitters connected to GND via a current source. This drives a pair of emitter-followers that require a 50 Ω to $V_{CC}-2.0$ load. A modern LVPECL driver will typically include the termination scheme within the device for the emitter follower. If the driver does not include the load, then an external scheme must be used. The 1.3 V supply is usually not readily available on a PCB, therefore, a load scheme without a unique power supply requirement may be used.

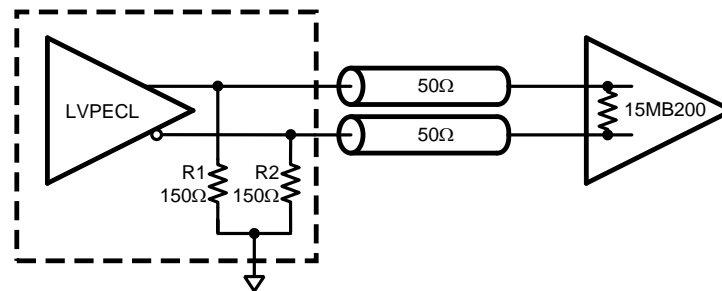

Figure 5. DC Coupled LVPECL to LVDS Interface

Figure 5 is a separated π termination scheme for a 3.3 V LVPECL driver. R1 and R2 provides proper DC load for the driver emitter followers, and may be included as part of the driver device.

NOTE

The bias networks shown above for LVPECL drivers and receivers may or may not be present within the driver device. The LVPECL driver and receiver specification must be reviewed closely to ensure compatibility between the driver and receiver terminations and common mode operating ranges.

The 15MB200 includes a 100Ω input termination for the transmission line. The common mode voltage will be at the normal LVPECL levels – around 2 V. This scheme works well with LVDS receivers that have rail-to-rail common mode voltage, V_{CM} , range. Most Texas Instruments LVDS receivers have wide V_{CM} range. The exceptions are noted in devices' respective datasheets. Those LVDS devices that do have a wide V_{CM} range do not vary in performance significantly when receiving a signal with a common mode other than standard LVDS V_{CM} of 1.2 V.

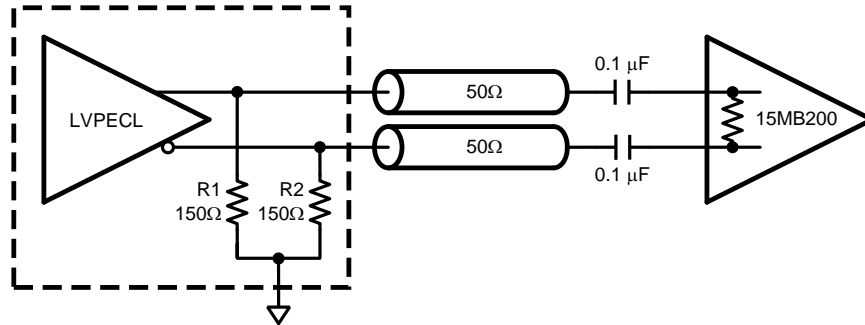

Figure 6. AC Coupled LVPECL to LVDS Interface

An AC coupled interface is preferred when transmitter and receiver ground references differ more than 1 V. This is a likely scenario when transmitter and receiver devices are on separate PCBs. Figure 6 illustrates an AC coupled interface between a LVPECL driver and LVDS receiver. R1 and R2, if not present in the driver device provide DC load for the emitter followers and may range between 140-220Ω for most LVPECL devices for this particular configuration.

NOTE

The bias networks shown above for LVPECL drivers and receivers may or may not be present within the driver device. The LVPECL driver and receiver specification must be reviewed closely to ensure compatibility between the driver and receiver terminations and common mode operating ranges.

The 15MB200 includes an internal 100Ω resistor to terminate the transmission line for minimal reflections. The signal after ac coupling capacitors will swing around a level set by internal biasing resistors (i.e. fail-safe) which is either $V_{DD}/2$ or 0 V depending on the actual failsafe implementation. If internal biasing is not implemented, the signal common mode voltage will slowly drift to GND level.

Interfacing LVDS to LVPECL

An LVDS driver consists of a current source (nominal 3.5mA) which drives a CMOS differential pair. It needs a differential resistive load in the range of 70 to 130Ω to generate LVDS levels. In a system, the load should be selected to match transmission line characteristic differential impedance so that the line is properly terminated. The termination resistor should be placed as close to the receiver inputs as possible. When interfacing an LVDS driver with a non-LVDS receiver, one only needs to bias the LVDS signal so that it is within the common mode range of the receiver. This may be done by using separate biasing voltage which demands another power supply. Some receivers have required biasing voltage available on-chip (V_T , V_{TT} or V_{BB}).

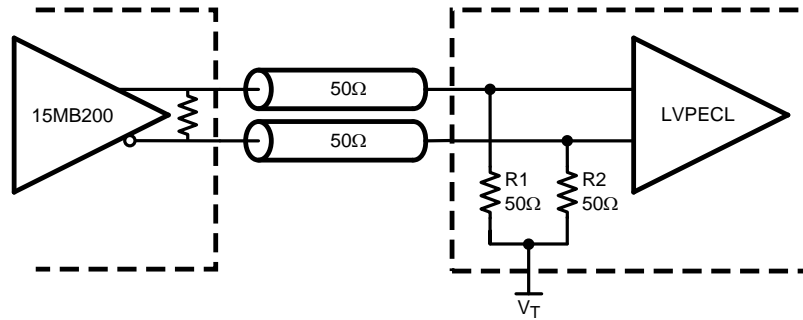

Figure 7. DC Coupled LVDS to LVPECL Interface

Figure 7 illustrates interface between an LVDS driver and a LVPECL with a V_T pin available. R1 and R2, if not present in the receiver, provide proper resistive load for the driver and termination for the transmission line, and V_T sets desired bias for the receiver.

NOTE

The bias networks shown above for LVPECL drivers and receivers may or may not be present within the driver device. The LVPECL driver and receiver specification must be reviewed closely to ensure compatibility between the driver and receiver terminations and common mode operating ranges.

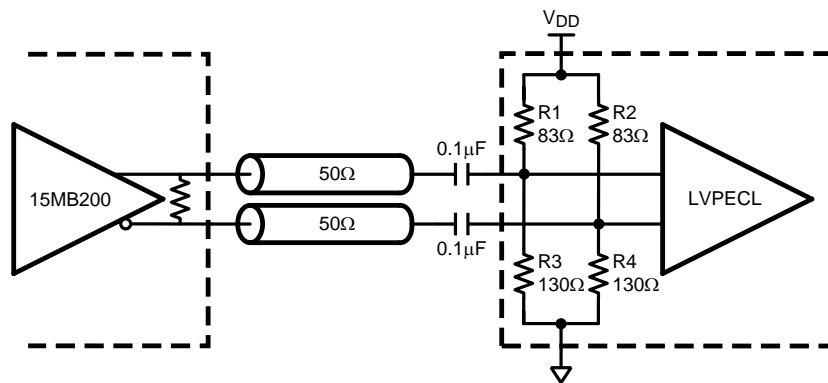

Figure 8. AC Coupled LVDS to LVPECL Interface

Figure 8 illustrates AC coupled interface between an LVDS driver and LVPECL receiver without a V_T pin available. The resistors R1, R2, R3, and R4, if not present in the receiver, provide a load for the driver, terminate the transmission line, and bias the signal for the receiver.

NOTE

The bias networks shown above for LVPECL drivers and receivers may or may not be present within the driver device. The LVPECL driver and receiver specification must be reviewed closely to ensure compatibility between the driver and receiver terminations and common mode operating ranges.

Design-For-Test (DfT) Features

IEEE 1149.1 SUPPORT

The SCAN15MB200 supports a fully compliant IEEE 1149.1 interface. The Test Access Port (TAP) provides access to boundary scan cells at each LVTTTL I/O on the device for interconnect testing. Differential pins are included in the same boundary scan chain but instead contain IEEE1149.6 cells. IEEE1149.6 is the improved IEEE standard for testing high-speed differential signals.

Refer to the BSDL file located on TI's website for the details of the SCAN15MB200 IEEE 1149.1 implementation.

IEEE 1149.6 SUPPORT

AC-coupled differential interconnections on very high speed (1+ Gbps) data paths are not testable using traditional IEEE 1149.1 techniques. The IEEE 1149.1 structures and methods are intended to test static (DC-coupled), single ended networks. IEEE 1149.6 is specifically designed for testing high-speed differential, including AC coupled networks.

The SCAN15MB200 is intended for high-speed signalling up to 1.5 Gbps and includes IEEE1149.6 on all differential inputs and outputs.

FAULT INSERTION

Fault Insertion is a technique used to assist in the verification and debug of diagnostic software. During system testing faults are "injected" to simulate hardware failure and thus help verify the monitoring software can detect and diagnose these faults. In the SCAN15MB200 an IEEE1149.1 "stuck-at" instruction can create a stuck-at condition, either high or low, on any pin or combination of pins. A more detailed description of the stuck-at feature can be found in TI Applications note AN-1313 ([SNLA060](#)).

Packaging Information

The WQFN package is a leadframe based chip scale package (CSP) that may enhance chip speed, reduce thermal impedance, and reduce the printed circuit board area required for mounting. The small size and very low profile make this package ideal for high density PCBs used in small-scale electronic applications such as cellular phones, pagers, and handheld PDAs. The WQFN package is offered in the no Pullback configuration. In the no Pullback configuration the standard solder pads extend and terminate at the edge of the package. This feature offers a visible solder fillet after board mounting.

The WQFN has the following advantages:



- Low thermal resistance
- Reduced electrical parasitics
- Improved board space efficiency
- Reduced package height
- Reduced package mass

For more details about WQFN packaging technology, refer to applications note AN-1187 ([SNOA401](#)), "Leadless Leadframe Package"

REVISION HISTORY

Changes from Revision D (April 2013) to Revision E	Page
• Changed layout of National Data Sheet to TI format	13

PACKAGING INFORMATION

Orderable Device	Status (1)	Package Type	Package Drawing	Pins	Package Qty	Eco Plan (2)	Lead finish/ Ball material (6)	MSL Peak Temp (3)	Op Temp (°C)	Device Marking (4/5)	Samples
SCAN15MB200TSQ/NOPB	ACTIVE	WQFN	RHS	48	250	RoHS & Green	SN	Level-3-260C-168 HR	-40 to 85	15MB200	
SCAN15MB200TSQX/NOPB	ACTIVE	WQFN	RHS	48	2500	RoHS & Green	SN	Level-3-260C-168 HR	-40 to 85	15MB200	

(1) The marketing status values are defined as follows:

ACTIVE: Product device recommended for new designs.

LIFEBUY: TI has announced that the device will be discontinued, and a lifetime-buy period is in effect.

NRND: Not recommended for new designs. Device is in production to support existing customers, but TI does not recommend using this part in a new design.

PREVIEW: Device has been announced but is not in production. Samples may or may not be available.

OBSELETE: TI has discontinued the production of the device.

(2) **RoHS:** TI defines "RoHS" to mean semiconductor products that are compliant with the current EU RoHS requirements for all 10 RoHS substances, including the requirement that RoHS substance do not exceed 0.1% by weight in homogeneous materials. Where designed to be soldered at high temperatures, "RoHS" products are suitable for use in specified lead-free processes. TI may reference these types of products as "Pb-Free".

RoHS Exempt: TI defines "RoHS Exempt" to mean products that contain lead but are compliant with EU RoHS pursuant to a specific EU RoHS exemption.

Green: TI defines "Green" to mean the content of Chlorine (Cl) and Bromine (Br) based flame retardants meet JS709B low halogen requirements of <=1000ppm threshold. Antimony trioxide based flame retardants must also meet the <=1000ppm threshold requirement.

(3) MSL, Peak Temp. - The Moisture Sensitivity Level rating according to the JEDEC industry standard classifications, and peak solder temperature.

(4) There may be additional marking, which relates to the logo, the lot trace code information, or the environmental category on the device.

(5) Multiple Device Markings will be inside parentheses. Only one Device Marking contained in parentheses and separated by a "~" will appear on a device. If a line is indented then it is a continuation of the previous line and the two combined represent the entire Device Marking for that device.

(6) Lead finish/Ball material - Orderable Devices may have multiple material finish options. Finish options are separated by a vertical ruled line. Lead finish/Ball material values may wrap to two lines if the finish value exceeds the maximum column width.

Important Information and Disclaimer:The information provided on this page represents TI's knowledge and belief as of the date that it is provided. TI bases its knowledge and belief on information provided by third parties, and makes no representation or warranty as to the accuracy of such information. Efforts are underway to better integrate information from third parties. TI has taken and continues to take reasonable steps to provide representative and accurate information but may not have conducted destructive testing or chemical analysis on incoming materials and chemicals. TI and TI suppliers consider certain information to be proprietary, and thus CAS numbers and other limited information may not be available for release.

In no event shall TI's liability arising out of such information exceed the total purchase price of the TI part(s) at issue in this document sold by TI to Customer on an annual basis.

TAPE AND REEL INFORMATION

QUADRANT ASSIGNMENTS FOR PIN 1 ORIENTATION IN TAPE



*All dimensions are nominal

Device	Package Type	Package Drawing	Pins	SPQ	Reel Diameter (mm)	Reel Width W1 (mm)	A0 (mm)	B0 (mm)	K0 (mm)	P1 (mm)	W (mm)	Pin1 Quadrant
SCAN15MB200TSQ/ NOPB	WQFN	RHS	48	250	178.0	16.4	7.3	7.3	1.3	12.0	16.0	Q1
SCAN15MB200TSQX/ NOPB	WQFN	RHS	48	2500	330.0	16.4	7.3	7.3	1.3	12.0	16.0	Q1

TAPE AND REEL BOX DIMENSIONS

*All dimensions are nominal

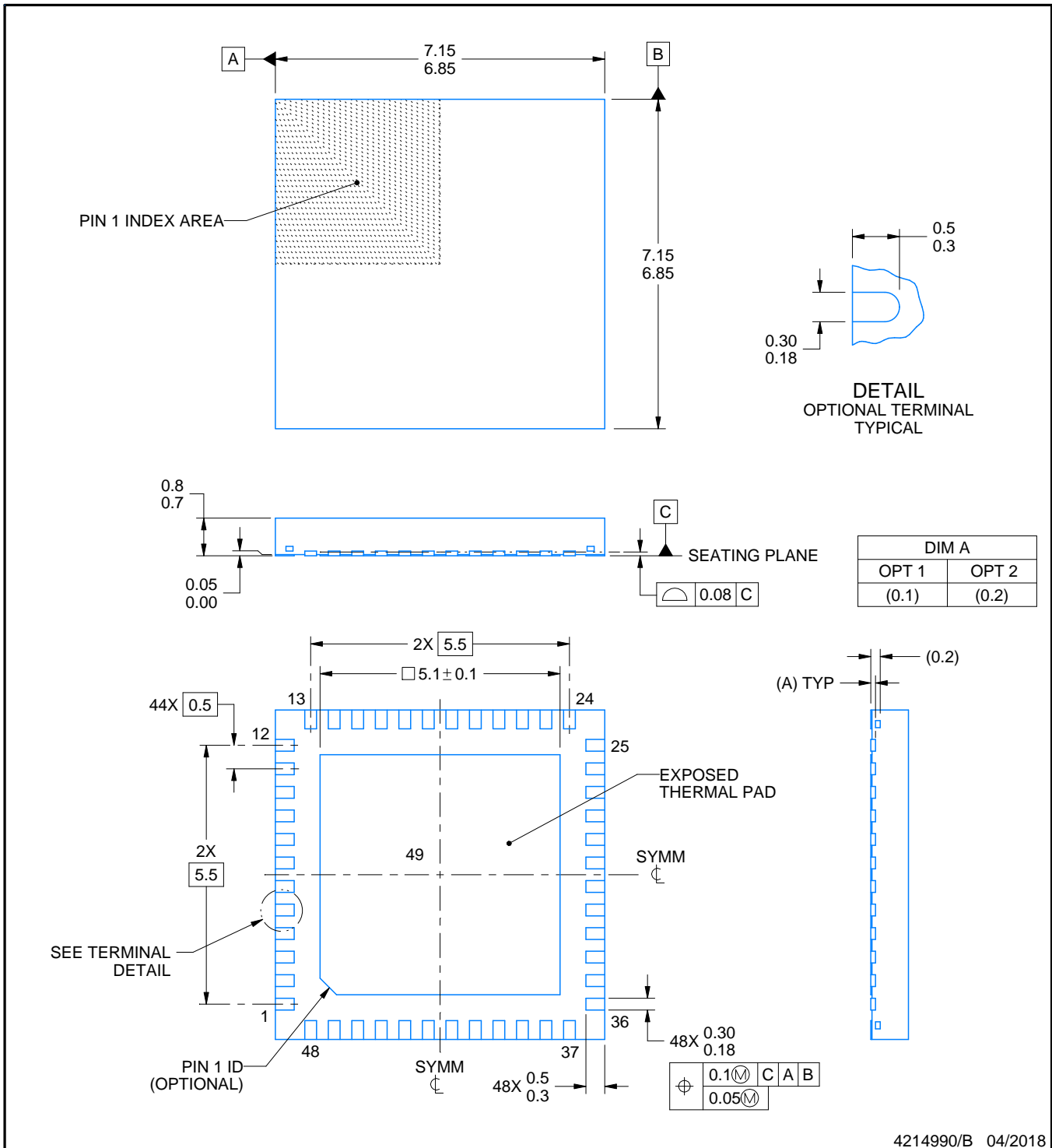
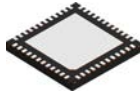
Device	Package Type	Package Drawing	Pins	SPQ	Length (mm)	Width (mm)	Height (mm)
SCAN15MB200TSQ/NOPB	WQFN	RHS	48	250	208.0	191.0	35.0
SCAN15MB200TSQX/ NOPB	WQFN	RHS	48	2500	356.0	356.0	36.0



4214990/B 04/2018

NOTES:

1. All linear dimensions are in millimeters. Any dimensions in parenthesis are for reference only. Dimensioning and tolerancing per ASME Y14.5M.
2. This drawing is subject to change without notice.
3. The package thermal pad must be soldered to the printed circuit board for thermal and mechanical performance.

EXAMPLE STENCIL DESIGN

RHS0048A

WQFN - 0.8 mm max height

PLASTIC QUAD FLATPACK - NO LEAD

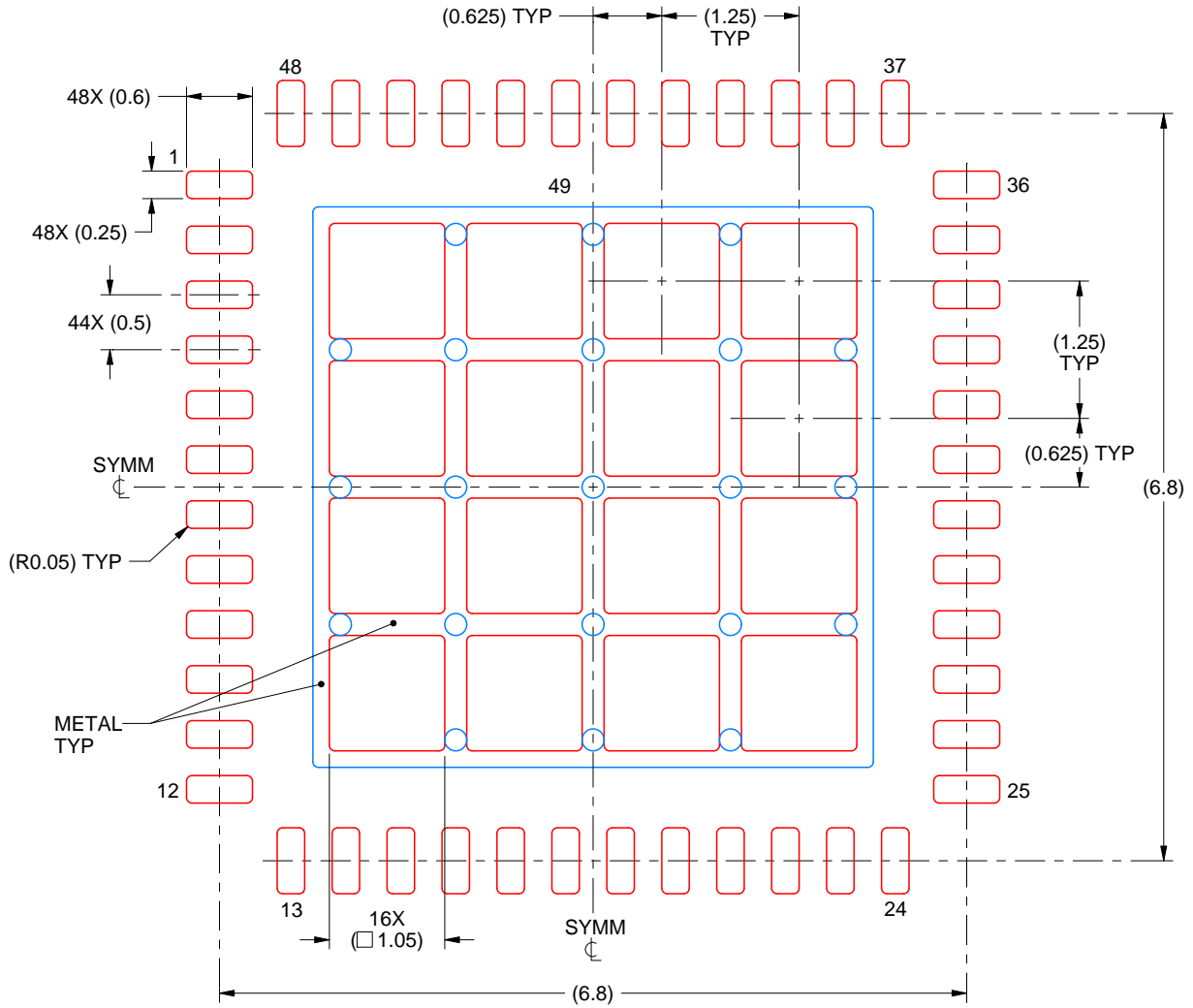

SOLDER PASTE EXAMPLE
BASED ON 0.125 mm THICK STENCIL

EXPOSED PAD 49
68% PRINTED SOLDER COVERAGE BY AREA UNDER PACKAGE
SCALE:15X

4214990/B 04/2018

NOTES: (continued)

6. Laser cutting apertures with trapezoidal walls and rounded corners may offer better paste release. IPC-7525 may have alternate design recommendations.

IMPORTANT NOTICE AND DISCLAIMER

TI PROVIDES TECHNICAL AND RELIABILITY DATA (INCLUDING DATA SHEETS), DESIGN RESOURCES (INCLUDING REFERENCE DESIGNS), APPLICATION OR OTHER DESIGN ADVICE, WEB TOOLS, SAFETY INFORMATION, AND OTHER RESOURCES "AS IS" AND WITH ALL FAULTS, AND DISCLAIMS ALL WARRANTIES, EXPRESS AND IMPLIED, INCLUDING WITHOUT LIMITATION ANY IMPLIED WARRANTIES OF MERCHANTABILITY, FITNESS FOR A PARTICULAR PURPOSE OR NON-INFRINGEMENT OF THIRD PARTY INTELLECTUAL PROPERTY RIGHTS.

These resources are intended for skilled developers designing with TI products. You are solely responsible for (1) selecting the appropriate TI products for your application, (2) designing, validating and testing your application, and (3) ensuring your application meets applicable standards, and any other safety, security, regulatory or other requirements.

These resources are subject to change without notice. TI grants you permission to use these resources only for development of an application that uses the TI products described in the resource. Other reproduction and display of these resources is prohibited. No license is granted to any other TI intellectual property right or to any third party intellectual property right. TI disclaims responsibility for, and you will fully indemnify TI and its representatives against, any claims, damages, costs, losses, and liabilities arising out of your use of these resources.

TI's products are provided subject to [TI's Terms of Sale](#) or other applicable terms available either on [ti.com](https://www.ti.com) or provided in conjunction with such TI products. TI's provision of these resources does not expand or otherwise alter TI's applicable warranties or warranty disclaimers for TI products.

TI objects to and rejects any additional or different terms you may have proposed.

Mailing Address: Texas Instruments, Post Office Box 655303, Dallas, Texas 75265
Copyright © 2024, Texas Instruments Incorporated