

TXB0108 8-Bit Bidirectional Voltage-Level Translator with Auto-Direction Sensing and $\pm 15\text{kV}$ ESD Protection

1 Features

- 1.2V to 3.6V on A Port and 1.65V to 5.5V on B Port ($V_{CCA} \leq V_{CCB}$)
- V_{CC} Isolation Feature – If Either V_{CC} Input Is at GND, All Outputs Are in the High-Impedance State
- OE Input Circuit Referenced to V_{CCA}
- Low Power Consumption, $4\mu\text{A}$ Max I_{CC}
- I_{off} Supports Partial-Power-Down Mode Operation
- Latch-Up Performance Exceeds 100mA Per JESD 78, Class II
- ESD Protection Exceeds JESD 22
 - A Port
 - 2000V Human-Body Model (A114-B)
 - 1000V Charged-Device Model (C101)
 - B Port
 - $\pm 15\text{kV}$ Human-Body Model (A114-B)
 - $\pm 8\text{kV}$ Human-Body Model (A114-B) (YZP Package Only)
 - 1000V Charged-Device Model (C101)

2 Applications

- Handset
- Smartphone
- Tablet
- Desktop PC

3 Description

This 8-bit noninverting translator uses two separate configurable power-supply rails. The A port is designed to track V_{CCA} . V_{CCA} accepts any supply voltage from 1.2V to 3.6V. The B port is designed to track V_{CCB} . V_{CCB} accepts any supply voltage from 1.65V to 5.5V. This allows for universal low-voltage bidirectional translation between any of the 1.2V, 1.5V, 1.8V, 2.5V, 3.3V, and 5V voltage nodes. V_{CCA} should not exceed V_{CCB} .

When the output-enable (OE) input is low, all outputs are placed in the high-impedance state.

The TXB0108 is designed so that the OE input circuit is supplied by V_{CCA} .

This device is fully specified for partial-power-down applications using I_{off} . The I_{off} circuitry disables the outputs, preventing damaging current backflow through the device when it is powered down.

To ensure the high-impedance state during power-up or power-down, OE should be tied to GND through a pulldown resistor; the minimum value of the resistor is determined by the current-sourcing capability of the driver.

Device Information

PART NUMBER	PACKAGE ⁽¹⁾	BODY SIZE (NOM)
TXB0108DQS	SON (20)	2.00mm x 4.00mm
TXB0108ZXY	BGA MICROSTAR JUNIOR (20)	2.50mm x 3.00mm
TXB0108PW	TSSOP (20)	6.50mm x 4.40mm
TXB0108RGY	VQFN (20)	4.50mm x 3.50mm
TXB0108YZP	DSGBA (20)	1.90mm x 2.40mm
TXB0108NME	nFBGA (20)	2.50mm x 3.00mm
TXB0108RUK	WQFN (20)	3.00mm x 3.00mm

(1) For all available packages, see the orderable addendum at the end of the datasheet.

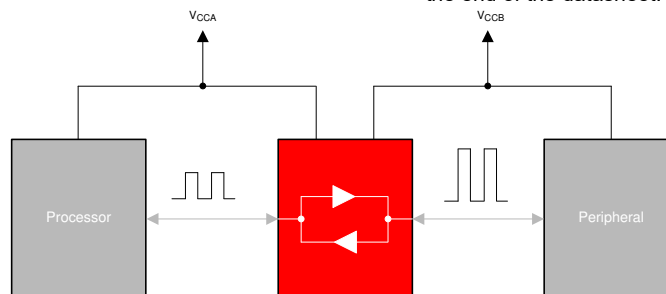

Typical Application Block Diagram for TXB0108

Table of Contents

1 Features	1	7 Detailed Description	12
2 Applications	1	7.1 Overview.....	12
3 Description	1	7.2 Functional Block Diagram.....	12
4 Pin Configuration and Functions	3	7.3 Feature Description.....	13
5 Specifications	5	7.4 Device Functional Modes.....	14
5.1 Absolute Maximum Ratings.....	5	8 Application and Implementation	15
5.2 Handling Ratings.....	5	8.1 Application Information.....	15
5.3 Recommended Operating Conditions.....	5	8.2 Typical Application.....	15
5.4 Thermal Information.....	6	9 Power Supply Recommendations	17
5.5 Electrical Characteristics.....	6	10 Layout	17
5.6 Timing Requirements: $V_{CCA} = 1.2\text{ V}$	7	10.1 Layout Guidelines.....	17
5.7 Timing Requirements: $V_{CCA} = 1.5\text{ V} \pm 0.1\text{ V}$	7	10.2 Layout Example.....	17
5.8 Timing Requirements: $V_{CCA} = 1.8\text{ V} \pm 0.15\text{ V}$	7	11 Device and Documentation Support	18
5.9 Timing Requirements: $V_{CCA} = 2.5\text{ V} \pm 0.2\text{ V}$	7	11.1 Receiving Notification of Documentation Updates..	18
5.10 Timing Requirements: $V_{CCA} = 3.3\text{ V} \pm 0.3\text{ V}$	8	11.2 Support Resources.....	18
5.11 Switching Characteristics: $V_{CCA} = 1.2\text{ V}$	8	11.3 Trademarks.....	18
5.12 Switching Characteristics: $V_{CCA} = 1.5\text{ V} \pm 0.1\text{ V}$	8	11.4 Electrostatic Discharge Caution.....	18
5.13 Switching Characteristics: $V_{CCA} = 1.8\text{ V} \pm 0.15\text{ V}$	9	11.5 Glossary.....	18
5.14 Switching Characteristics: $V_{CCA} = 2.5\text{ V} \pm 0.2\text{ V}$	9	12 Revision History	19
5.15 Switching Characteristics: $V_{CCA} = 3.3\text{ V} \pm 0.3\text{ V}$	9	13 Mechanical, Packaging, and Orderable Information	19
5.16 Operating Characteristics.....	10	13.1 Package Addendum.....	20
5.17 Typical Characteristics.....	10		
6 Parameter Measurement Information	11		

4 Pin Configuration and Functions

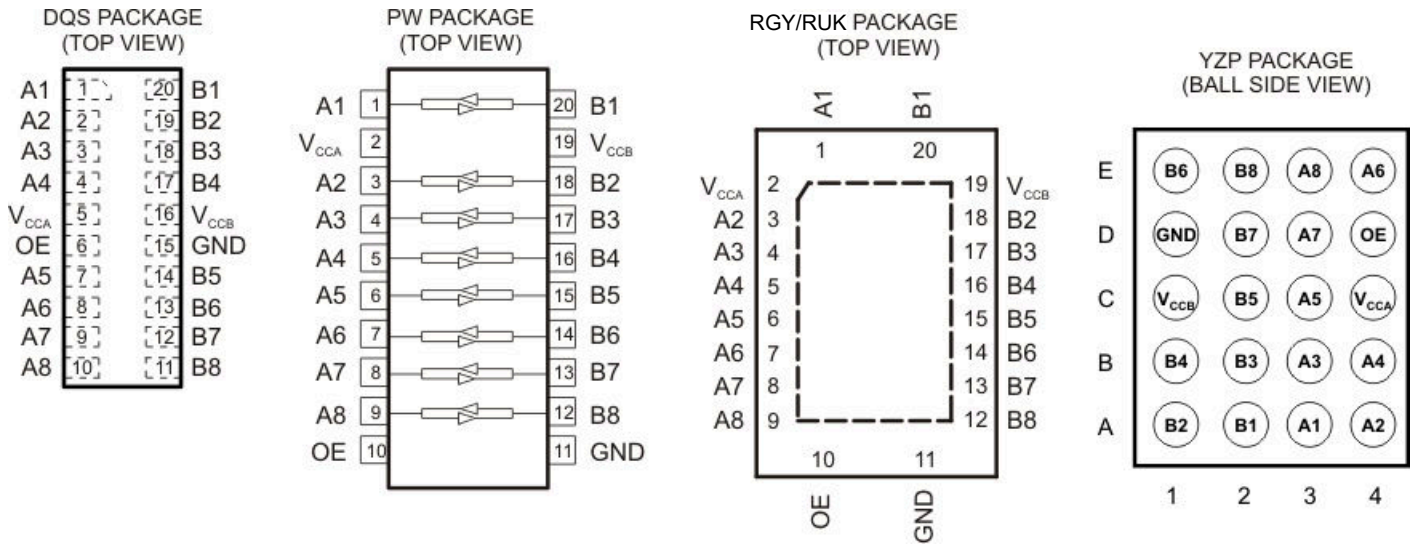

- A. For the RGY/RUK package, the exposed center thermal pad must be connected to ground.
- B. Pullup resistors are not required on both sides for Logic I/O.
- C. If pullup or pulldown resistors are needed, the resistor value must be over 50kΩ.
- D. 50 kΩ is a safe recommended value, if the customer can accept higher V_{OL} or lower V_{OH}, smaller pullup or pulldown resistor is allowed, the draft estimation is V_{OL} = V_{CCOUT} × 4.5 k/(4.5 k + R_{PU}) and V_{OH} = V_{CCOUT} × R_{DW}/(4.5 k + R_{DW}).
- E. If pullup resistors are needed, please refer to the TXS0108 or contact TI.
- F. For detailed information, please refer [A Guide to Voltage Translation With TXB-Type Translators](#).

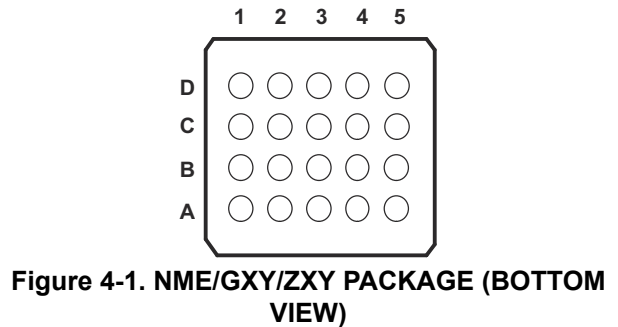
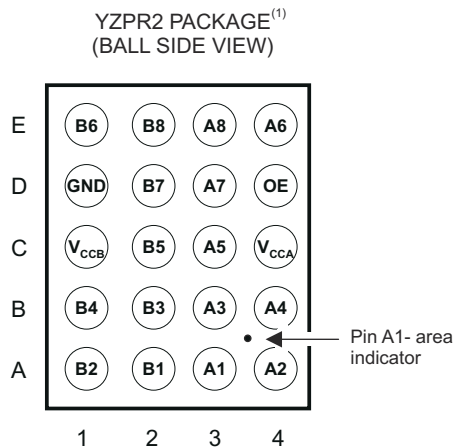

⁽¹⁾ See orderable addendum at the end of the data sheet

ADVANCE INFORMATION

Table 4-1. Pin Functions

PIN				I/O ⁽¹⁾	FUNCTION
SIGNAL NAME	PW, RGY NO.	DQS NO.	YZP GRID LOCATOR		
A1	1	1	A3	I/O	Input/output 1. Referenced to V_{CCA} .
V_{CCA}	2	5	C4	S	A-port supply voltage. $1.1\text{ V} \leq V_{CCA} \leq 3.6\text{ V}$, $V_{CCA} \leq V_{CCB}$.
A2	3	2	A4	I/O	Input/output 2. Referenced to V_{CCA} .
A3	4	3	B3	I/O	Input/output 3. Referenced to V_{CCA} .
A4	5	4	B4	I/O	Input/output 4. Referenced to V_{CCA} .
A5	6	7	C3	I/O	Input/output 5. Referenced to V_{CCA} .
A6	7	8	E4	I/O	Input/output 6. Referenced to V_{CCA} .
A7	8	9	D3	I/O	Input/output 7. Referenced to V_{CCA} .
A8	9	10	E3	I/O	Input/output 8. Referenced to V_{CCA} .
OE	10	6	D4	I	Output enable. Pull OE low to place all outputs in 3-state mode. Referenced to V_{CCA} .
GND	11	15	D1	S	Ground
B8	12	11	E2	I/O	Input/output 8. Referenced to V_{CCB} .
B7	13	12	D2	I/O	Input/output 7. Referenced to V_{CCB} .
B6	14	13	E1	I/O	Input/output 6. Referenced to V_{CCB} .
B5	15	14	C2	I/O	Input/output 5. Referenced to V_{CCB} .
B4	16	17	B1	I/O	Input/output 4. Referenced to V_{CCB} .
B3	17	18	B2	I/O	Input/output 3. Referenced to V_{CCB} .
B2	18	19	A1	I/O	Input/output 2. Referenced to V_{CCB} .
V_{CCB}	19	16	C1	S	B-port supply voltage. $1.65\text{ V} \leq V_{CCB} \leq 5.5\text{ V}$.
B1	20	20	A2	I/O	Input/output 1. Referenced to V_{CCB} .
Thermal Pad	—			—	For the RGY/RUK package, the exposed center thermal pad must be connected to ground.

(1) I = input, O = output, I/O = input and output, S = power supply

Table 4-2. Pin Assignments (20-Ball NME/GXY/ZXY Package)

	1	2	3	4	5
D	V_{CCB}	B2	B4	B6	B8
C	B1	B3	B5	B7	GND
B	A1	A3	A5	A7	OE
A	V_{CCA}	A2	A4	A6	A8

5 Specifications

5.1 Absolute Maximum Ratings

over operating free-air temperature range (unless otherwise noted)

		(1)	MIN	MAX	UNIT
V _{CCA}	Supply voltage range		-0.5	4.6	V
V _{CCB}	Supply voltage range		-0.5	6.5	V
V _I	Input voltage range ⁽²⁾		-0.5	6.5	V
V _O	Voltage range applied to any output in the high-impedance or power-off state ⁽²⁾		-0.5	6.5	V
V _O	Voltage range applied to any output in the high or low state ^{(2) (3)}	A inputs	-0.5	V _{CCA} + 0.5	V
		B inputs	-0.5	V _{CCB} + 0.5	
I _{IK}	Input clamp current	V _I < 0		-50	mA
I _{OK}	Output clamp current	V _O < 0		-50	mA
I _O	Continuous output current			±50	mA
	Continuous current through V _{CCA} , V _{CCB} , or GND			±100	mA
T _{stg}	Storage temperature range		-65	150	°C
T _J	Junction temperature			150	°C

- (1) Stresses beyond those listed under *Absolute Maximum Ratings* may cause permanent damage to the device. These are stress ratings only, and functional operation of the device at these or any other conditions beyond those indicated under *Recommended Operating Conditions* is not implied. Exposure to absolute-maximum-rated conditions for extended periods may affect device reliability.
- (2) The input and output negative-voltage ratings may be exceeded if the input and output current ratings are observed.
- (3) The value of V_{CCA} and V_{CCB} are provided in the recommended operating conditions table.

5.2 Handling Ratings

			MIN	MAX	UNIT
V _(ESD)	Electrostatic discharge	Human body model (HBM), per ANSI/ESDA/JEDEC JS-001, all pins ⁽¹⁾ , A Port		2	kV
		Human body model (HBM), per ANSI/ESDA/JEDEC JS-001, all pins ⁽¹⁾ , B Port	-15	15	
		Charged device model (CDM), per JEDEC specification JESD22-C101, all pins ⁽²⁾ , A Port		1	
		Charged device model (CDM), per JEDEC specification JESD22-C101, all pins ⁽²⁾ , A Port (YZP Package only)	-8	8	
		Charged device model (CDM), per JEDEC specification JESD22-C101, all pins ⁽²⁾ , B Port		1	

- (1) JEDEC document JEP155 states that 500-V HBM allows safe manufacturing with a standard ESD control process.
- (2) JEDEC document JEP157 states that 250-V CDM allows safe manufacturing with a standard ESD control process.

5.3 Recommended Operating Conditions

over operating free-air temperature range (unless otherwise noted)^{(1) (2)}

			V _{CCA}	V _{CCB}	MIN	MAX	UNIT
V _{CCA}	Supply voltage				1.2	3.6	V
V _{CCB}					1.65	5.5	
V _{IH}	High-level input voltage	Data inputs	1.2 V to 3.6 V	1.65 V to 5.5 V	V _{CCI} × 0.65 ⁽³⁾	V _{CCI}	V
		OE			V _{CCA} × 0.65	5.5	
V _{IL}	Low-level input voltage	Data inputs	1.2 V to 5.5 V	1.65 V to 5.5 V	0	V _{CCI} × 0.35 ⁽³⁾	V
		OE			1.2 V to 3.6 V	0	
Δt/Δv	Input transition rise or fall rate	A-port inputs	1.2 V to 3.6 V	1.65 V to 5.5 V		40	ns/V
		B-port inputs	1.2 V to 3.6 V	1.65 V to 3.6 V		40	
				4.5 V to 5.5 V		30	

5.3 Recommended Operating Conditions (continued)

 over operating free-air temperature range (unless otherwise noted)^{(1) (2)}

	V_{CCA}	V_{CCB}	MIN	MAX	UNIT
T_A Operating free-air temperature			-40	85	°C

 (1) The A and B sides of an unused data I/O pair must be held in the same state, i.e., both at V_{CCI} or both at GND.

 (2) V_{CCA} must be less than or equal to V_{CCB} and must not exceed 3.6 V.

 (3) V_{CCI} is the supply voltage associated with the input port.

5.4 Thermal Information

THERMAL METRIC ⁽¹⁾		TXB0108								UNIT
		PW	RGY	DQS	YZP	GXY	ZXY	NME	RUK	
		20 PINS								
$R_{\theta JA}$	Junction-to-ambient thermal resistance	101.8	35.3	108.5	66.2	156.7	156.7	131.4	TBD	°C/W
$R_{\theta JC(top)}$	Junction-to-case (top) thermal resistance	35.5	42.1	32.3	0.4	39.9	39.9	56.5	TBD	°C/W
$R_{\theta JB}$	Junction-to-board thermal resistance	52.8	11.1	42.4	52.0	85.9	85.9	83.2	TBD	°C/W
Ψ_{JT}	Junction-to-top characterization parameter	2.2	0.7	0.7	1.5	1.1	1.1	1.5	TBD	°C/W
Ψ_{JB}	Junction-to-board characterization parameter	52.2	11.2	42	51.9	85.4	85.4	82.6	TBD	°C/W
$R_{\theta JC(bot)}$	Junction-to-case (bottom) thermal resistance	–	3.8	–	–	–	–	–	TBD	°C/W

 (1) For more information about traditional and new thermal metrics, see the *IC Package Thermal Metrics* application report, [SPRA953](#).

5.5 Electrical Characteristics

 over recommended operating free-air temperature range (unless otherwise noted)^{(1) (2)}

PARAMETER	TEST CONDITIONS	V_{CCA}	V_{CCB}	$T_A = 25^\circ\text{C}$			$-40^\circ\text{C to } 85^\circ\text{C}$		UNIT	
				MIN	TYP	MAX	MIN	MAX		
V_{OHA}	$I_{OH} = -20 \mu\text{A}$	1.2 V		1.1			$V_{CCA} - 0.4$		V	
		1.4 V to 3.6 V								
V_{OLA}	$I_{OL} = 20 \mu\text{A}$	1.2 V		0.3			0.4		V	
		1.4 V to 3.6 V								
V_{OHB}	$I_{OH} = -20 \mu\text{A}$		1.65 V to 5.5 V				$V_{CCB} - 0.4$		V	
V_{OLB}	$I_{OL} = 20 \mu\text{A}$		1.65 V to 5.5 V				0.4		V	
I_I	OE	1.2 V to 3.6 V	1.65 V to 5.5 V	± 1			± 2		μA	
I_{off}	A port	0 V	0 V to 5.5 V	± 1			± 2		μA	
	B port	0 V to 3.6 V	0 V	± 1			± 2			
I_{OZ}	A or B port	OE = GND	1.2 V to 3.6 V	1.65 V to 5.5 V	± 1			± 2		μA
I_{CCA}	$V_I = V_{CCI} \text{ or GND, } I_O = 0$	1.2 V	1.65 V to 5.5 V	0.06					μA	
		1.4 V to 3.6 V		5						
		3.6 V	0 V	2						
		0 V	5.5 V	-2						
I_{CCB}	$V_I = V_{CCI} \text{ or GND, } I_O = 0$	1.2 V	1.65 V to 5.5 V	3.4					μA	
		1.4 V to 3.6 V		5						
		3.6 V	0 V	-2						
		0 V	5.5 V	2						
$I_{CCA} + I_{CCB}$	$V_I = V_{CCI} \text{ or GND, } I_O = 0$	1.2 V	1.65 V to 5.5 V	3.5					μA	
		1.4 V to 3.6 V		10						

5.5 Electrical Characteristics (continued)

over recommended operating free-air temperature range (unless otherwise noted)^{(1) (2)}

PARAMETER	TEST CONDITIONS	V _{CCA}	V _{CCB}	T _A = 25°C			-40°C to 85°C		UNIT
				MIN	TYP	MAX	MIN	MAX	
I _{CCZA}	V _I = V _{CCI} or GND, I _O = 0, OE = GND	1.2 V	1.65 V to 5.5 V	0.05					μA
		1.4 V to 3.6 V					5		
I _{CCZB}	V _I = V _{CCI} or GND, I _O = 0, OE = GND	1.2 V	1.65 V to 5.5 V	3.3					μA
		1.4 V to 3.6 V					5		
C _I	OE	1.2 V to 3.6 V	1.65 V to 5.5 V	5			5.5	pF	
C _{io}	A port	1.2 V to 3.6 V	1.65 V to 5.5 V	5			6.5		pF
	B port			8			10		

- (1) V_{CCI} is the supply voltage associated with the input port.
(2) V_{CCO} is the supply voltage associated with the output port.

5.6 Timing Requirements: V_{CCA} = 1.2 V

T_A = 25°C, V_{CCA} = 1.2 V

			V _{CCB} = 1.8 V	V _{CCB} = 2.5 V	V _{CCB} = 3.3 V	V _{CCB} = 5 V	UNIT
			TYP	TYP	TYP	TYP	
Data rate			20	20	20	20	Mbps
t _w	Pulse duration	Data inputs	50	50	50	50	ns

5.7 Timing Requirements: V_{CCA} = 1.5 V ± 0.1 V

over recommended operating free-air temperature range, V_{CCA} = 1.5 V ± 0.1 V (unless otherwise noted)

			V _{CCB} = 1.8 V ± 0.15 V		V _{CCB} = 2.5 V ± 0.2 V		V _{CCB} = 3.3 V ± 0.3 V		V _{CCB} = 5 V ± 0.5 V		UNIT
			MIN	MAX	MIN	MAX	MIN	MAX	MIN	MAX	
Data rate			50		50		50		50		Mbps
t _w	Pulse duration	Data inputs	20		20		20		20		ns

5.8 Timing Requirements: V_{CCA} = 1.8 V ± 0.15 V

over recommended operating free-air temperature range, V_{CCA} = 1.8 V ± 0.15 V (unless otherwise noted)

			V _{CCB} = 1.8 V ± 0.15 V		V _{CCB} = 2.5 V ± 0.2 V		V _{CCB} = 3.3 V ± 0.3 V		V _{CCB} = 5 V ± 0.5 V		UNIT
			MIN	MAX	MIN	MAX	MIN	MAX	MIN	MAX	
Data rate			52		60		60		60		Mbps
t _w	Pulse duration	Data inputs	19		17		17		17		ns

5.9 Timing Requirements: V_{CCA} = 2.5 V ± 0.2 V

over recommended operating free-air temperature range, V_{CCA} = 2.5 V ± 0.2 V (unless otherwise noted)

			V _{CCB} = 2.5 V ± 0.2 V		V _{CCB} = 3.3 V ± 0.3 V		V _{CCB} = 5 V ± 0.5 V		UNIT
			MIN	MAX	MIN	MAX	MIN	MAX	
Data rate			70		100		100		Mbps
t _w	Pulse duration	Data inputs	14		10		10		ns

5.10 Timing Requirements: $V_{CCA} = 3.3\text{ V} \pm 0.3\text{ V}$

 over recommended operating free-air temperature range, $V_{CCA} = 3.3\text{ V} \pm 0.3\text{ V}$ (unless otherwise noted)

			$V_{CCB} = 3.3\text{ V} \pm 0.3\text{ V}$		$V_{CCB} = 5\text{ V} \pm 0.5\text{ V}$		UNIT
			MIN	MAX	MIN	MAX	
Data rate			100		100		Mbps
t_w	Pulse duration	Data inputs	10		10		ns

5.11 Switching Characteristics: $V_{CCA} = 1.2\text{ V}$

 $T_A = 25^\circ\text{C}$, $V_{CCA} = 1.2\text{ V}$

PARAMETER	FROM (INPUT)	TO (OUTPUT)	$V_{CCB} = 1.8\text{ V}$	$V_{CCB} = 2.5\text{ V}$	$V_{CCB} = 3.3\text{ V}$	$V_{CCB} = 5\text{ V}$	UNIT
			TYP	TYP	TYP	TYP	
t_{pd}	A	B	9.5	7.9	7.6	8.5	ns
	B	A	9.2	8.8	8.4	8	
t_{en}	OE	A	1	1	1	1	μs
		B	1	1	1	1	
t_{dis}	OE	A	20	17	17	18	ns
		B	20	16	15	15	
t_{rA} , t_{fA}	A-port rise and fall times		4.1	4.4	4.1	3.9	ns
t_{rB} , t_{fB}	B-port rise and fall times		5	5	5.1	5.1	ns
$t_{SK(O)}$	Channel-to-channel skew		2.4	1.7	1.9	7	ns
Max data rate			20	20	20	20	Mbps

5.12 Switching Characteristics: $V_{CCA} = 1.5\text{ V} \pm 0.1\text{ V}$

 over recommended operating free-air temperature range, $V_{CCA} = 1.5\text{ V} \pm 0.1\text{ V}$ (unless otherwise noted)

PARAMETER	FROM (INPUT)	TO (OUTPUT)	$V_{CCB} = 1.8\text{ V} \pm 0.15\text{ V}$		$V_{CCB} = 2.5\text{ V} \pm 0.2\text{ V}$		$V_{CCB} = 3.3\text{ V} \pm 0.3\text{ V}$		$V_{CCB} = 5\text{ V} \pm 0.5\text{ V}$		UNIT
			MIN	MAX	MIN	MAX	MIN	MAX	MIN	MAX	
t_{pd}	A	B	1.4	12.9	1.2	10.1	1.1	10	0.8	9.9	ns
	B	A	0.9	14.2	0.7	12	0.4	11.7	0.3	13.7	
t_{en}	OE	A	1		1		1		1		μs
		B	1		1		1		1		
t_{dis}	OE	A	6.6	33	6.4	25.3	6.1	23.1	5.9	24.6	ns
		B	6.6	35.6	5.8	25.6	5.5	22.1	5.6	20.6	
t_{rA} , t_{fA}	A-port rise and fall times		0.8	6.5	0.8	6.3	0.8	6.3	0.8	6.3	ns
t_{rB} , t_{fB}	B-port rise and fall times		1	7.3	0.7	4.9	0.7	4.6	0.6	4.6	ns
$t_{SK(O)}$	Channel-to-channel skew		2.6		1.9		1.6		1.3		ns
Max data rate			50		50		50		50		Mbps

5.13 Switching Characteristics: $V_{CCA} = 1.8\text{ V} \pm 0.15\text{ V}$

over recommended operating free-air temperature range, $V_{CCA} = 1.8\text{ V} \pm 0.15\text{ V}$ (unless otherwise noted)

PARAMETER	FROM (INPUT)	TO (OUTPUT)	$V_{CCB} = 1.8\text{ V} \pm 0.15\text{ V}$		$V_{CCB} = 2.5\text{ V} \pm 0.2\text{ V}$		$V_{CCB} = 3.3\text{ V} \pm 0.3\text{ V}$		$V_{CCB} = 5\text{ V} \pm 0.5\text{ V}$		UNIT
			MIN	MAX	MIN	MAX	MIN	MAX	MIN	MAX	
t_{pd}	A	B	1.6	11	1.4	7.7	1.3	6.8	1.2	6.5	ns
	B	A	1.5	12	1.2	8.4	0.8	7.6	0.5	7.1	
t_{en}	OE	A		1		1		1		1	μs
		B		1		1		1		1	
t_{dis}	OE	A	5.9	26.7	5.6	21.6	5.4	18.9	4.8	18.7	ns
		B	6.1	33.9	5.2	23.7	5	19.9	5	17.6	
t_{rA}, t_{fA}	A-port rise and fall times		0.7	5.1	0.7	5	1	5	0.7	5	ns
t_{rB}, t_{fB}	B-port rise and fall times		1	7.3	0.7	5	0.7	3.9	0.6	3.8	ns
$t_{SK(O)}$	Channel-to-channel skew			0.8		0.7		0.6		0.6	ns
Max data rate			52		60		60		60		Mbps

5.14 Switching Characteristics: $V_{CCA} = 2.5\text{ V} \pm 0.2\text{ V}$

over recommended operating free-air temperature range, $V_{CCA} = 2.5\text{ V} \pm 0.2\text{ V}$ (unless otherwise noted)

PARAMETER	FROM (INPUT)	TO (OUTPUT)	$V_{CCB} = 2.5\text{ V} \pm 0.2\text{ V}$		$V_{CCB} = 3.3\text{ V} \pm 0.3\text{ V}$		$V_{CCB} = 5\text{ V} \pm 0.5\text{ V}$		UNIT
			MIN	MAX	MIN	MAX	MIN	MAX	
t_{pd}	A	B	1.1	6.4	1	5.3	0.9	4.7	ns
	B	A	1	7	0.6	5.6	0.3	4.4	
t_{en}	OE	A		1		1		1	μs
		B		1		1		1	
t_{dis}	OE	A	5	16.9	4.9	15	4.5	13.8	ns
		B	4.8	21.8	4.5	17.9	4.4	15.2	
t_{rA}, t_{fA}	A-port rise and fall times		0.8	3.6	0.6	3.6	0.5	3.5	ns
t_{rB}, t_{fB}	B-port rise and fall times		0.6	4.9	0.7	3.9	0.6	3.2	ns
$t_{SK(O)}$	Channel-to-channel skew			0.4		0.3		0.3	ns
Max data rate			70		100		100		Mbps

5.15 Switching Characteristics: $V_{CCA} = 3.3\text{ V} \pm 0.3\text{ V}$

over recommended operating free-air temperature range, $V_{CCA} = 3.3\text{ V} \pm 0.3\text{ V}$ (unless otherwise noted)

PARAMETER	FROM (INPUT)	TO (OUTPUT)	$V_{CCB} = 3.3\text{ V} \pm 0.3\text{ V}$		$V_{CCB} = 5\text{ V} \pm 0.5\text{ V}$		UNIT
			MIN	MAX	MIN	MAX	
t_{pd}	A	B	0.9	4.9	0.8	4	ns
	B	A	0.5	5.4	0.2	4	
t_{en}	OE	A		1		1	μs
		B		1		1	
t_{dis}	OE	A	4.5	13.9	4.1	12.4	ns
		B	4.1	17.3	4	14.4	
t_{rA}, t_{fA}	A-port rise and fall times		0.5	3	0.5	3	ns
t_{rB}, t_{fB}	B-port rise and fall times		0.7	3.9	0.6	3.2	ns
$t_{SK(O)}$	Channel-to-channel skew			0.4		0.3	ns
Max data rate			100		100		Mbps

5.16 Operating Characteristics

T_A = 25°C

PARAMETER	TEST CONDITIONS	V _{CCA}							UNIT	
		1.2 V	1.2 V	1.5 V	1.8 V	2.5 V	2.5 V	3.3 V		
		V _{CCB}								
		5 V	1.8 V	1.8 V	1.8 V	2.5 V	5 V	3.3 V to 5 V		
		TYP	TYP	TYP	TYP	TYP	TYP	TYP		
C _{pdA}	A-port input, B-port output	C _L = 0, f = 10 MHz, t _r = t _f = 1 ns, OE = V _{CCA} (outputs enabled)	9	8	7	7	7	7	8	pF
	B-port input, A-port output		12	11	11	11	11	11	11	
C _{pdB}	A-port input, B-port output		35	26	27	27	27	27	28	
	B-port input, A-port output		26	19	18	18	18	20	21	
C _{pdA}	A-port input, B-port output	C _L = 0, f = 10 MHz, t _r = t _f = 1 ns, OE = GND (outputs disabled)	0.01	0.01	0.01	0.01	0.01	0.01	0.01	pF
	B-port input, A-port output		0.01	0.01	0.01	0.01	0.01	0.01	0.01	
C _{pdB}	A-port input, B-port output		0.01	0.01	0.01	0.01	0.01	0.01	0.03	
	B-port input, A-port output		0.01	0.01	0.01	0.01	0.01	0.01	0.03	

ADVANCE INFORMATION

5.17 Typical Characteristics

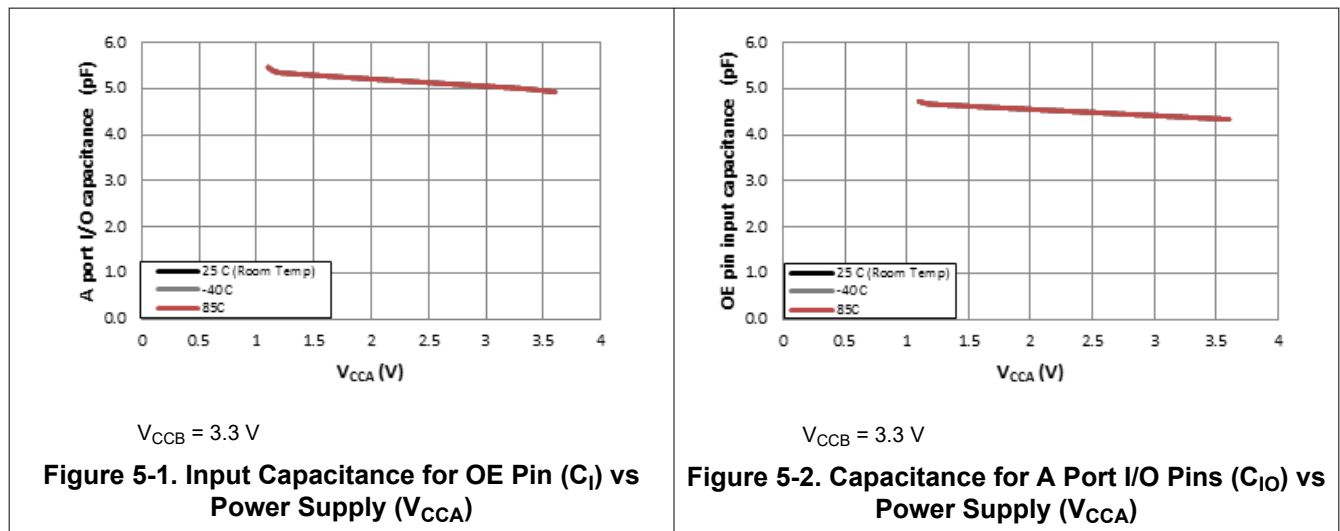

Figure 5-1. Input Capacitance for OE Pin (C₁) vs Power Supply (V_{CCA})

Figure 5-2. Capacitance for A Port I/O Pins (C_{1O}) vs Power Supply (V_{CCA})

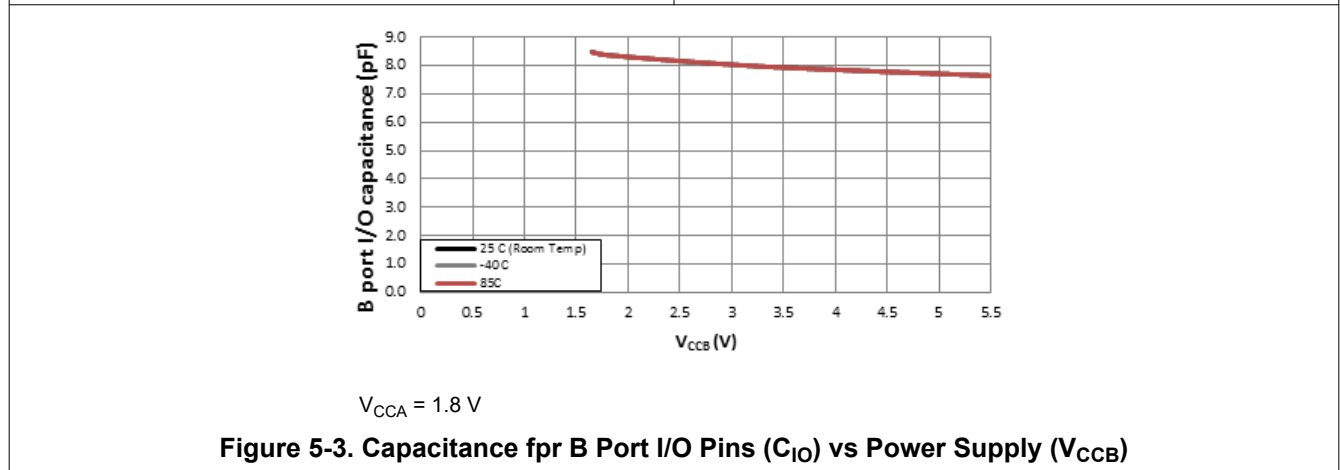
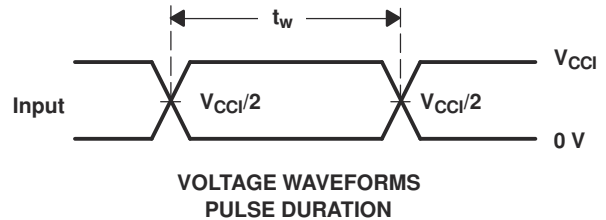
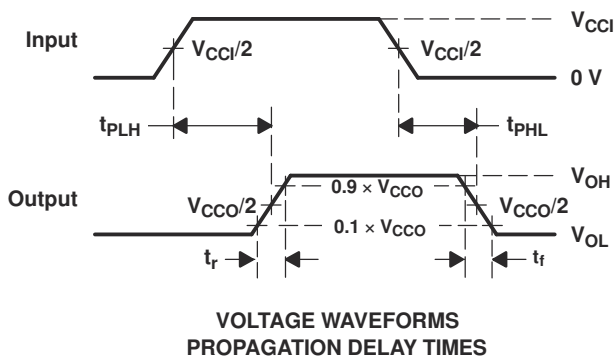
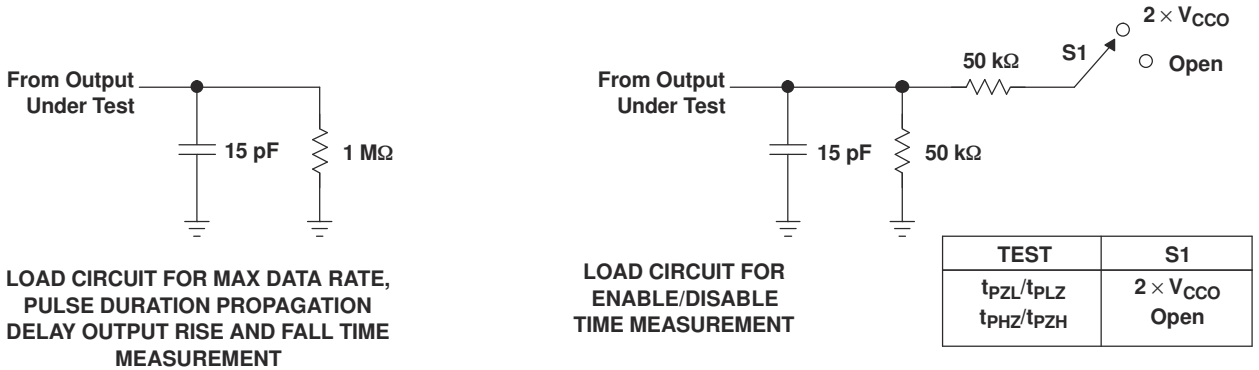

Figure 5-3. Capacitance for B Port I/O Pins (C_{1O}) vs Power Supply (V_{CCB})

6 Parameter Measurement Information



- C_L includes probe and jig capacitance.
- All input pulses are supplied by generators having the following characteristics: $PRR \leq 10$ MHz, $Z_O = 50 \Omega$, $dv/dt \geq 1$ V/ns.
- The outputs are measured one at a time, with one transition per measurement.
- t_{PLH} and t_{PHL} are the same as t_{pd} .
- V_{CCI} is the V_{CC} associated with the input port.
- V_{CCO} is the V_{CC} associated with the output port.
- All parameters and waveforms are not applicable to all devices.

Figure 6-1. Load Circuits and Voltage Waveforms

7 Detailed Description

7.1 Overview

The TXB0108 device is an 8-bit, directionless voltage-level translator specifically designed for translating logic voltage levels. The A port is able to accept I/O voltages ranging from 1.2 V to 3.6 V, while the B port can accept I/O voltages from 1.65 V to 5.5 V. The device is a buffered architecture with edge-rate accelerators (one-shots) to improve the overall data rate. This device can only translate push-pull CMOS logic outputs. If for open-drain signal translation, please refer to TI [TXS](#) products.

7.2 Functional Block Diagram

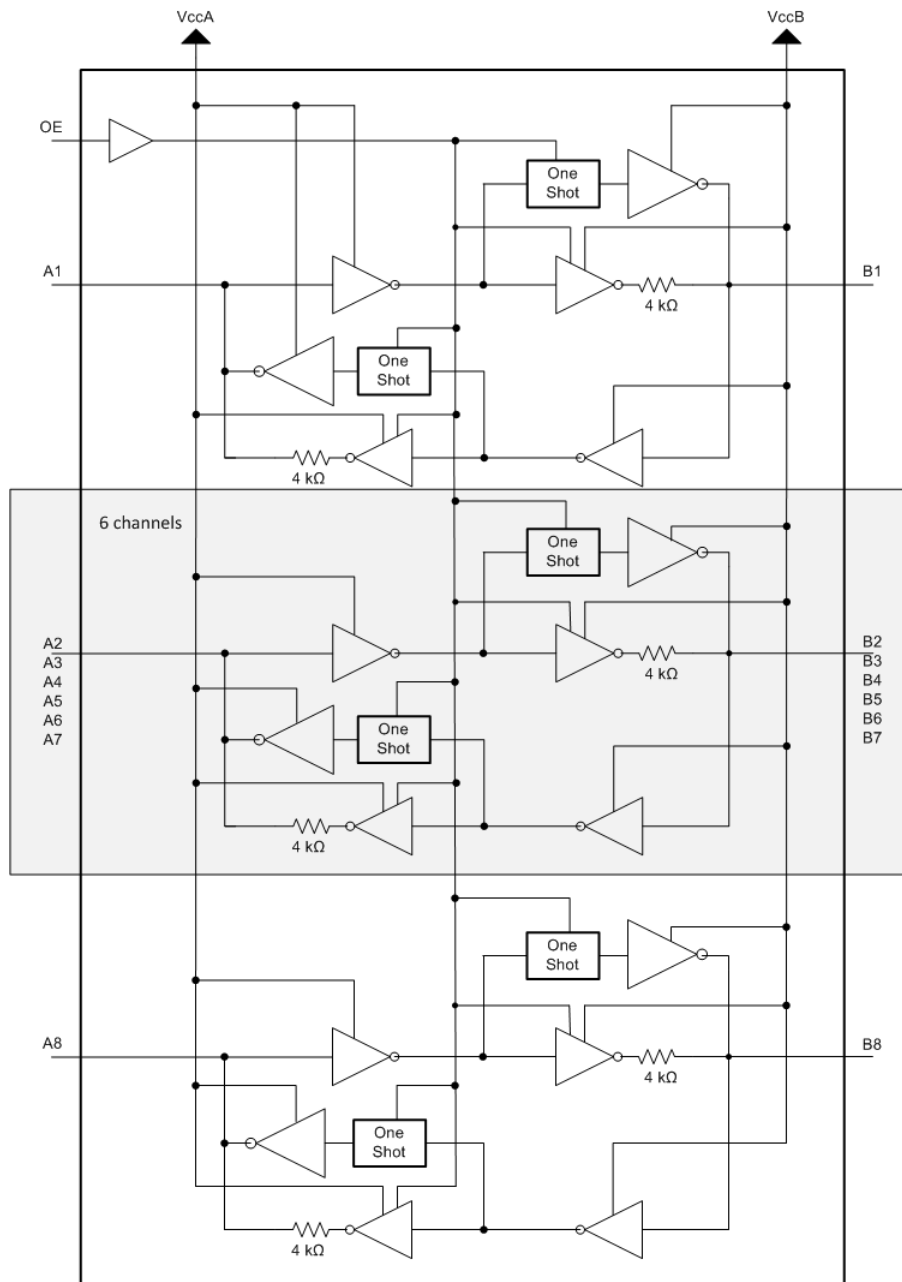

ADVANCE INFORMATION

7.3 Feature Description

7.3.1 Architecture

The TXB0108 architecture (see Figure 7-1) does not require a direction-control signal to control the direction of data flow from A to B or from B to A. In a dc state, the output drivers of the TXB0108 can maintain a high or low, but are designed to be weak so that they can be overdriven by an external driver when data on the bus starts flowing the opposite direction. The output one-shots detect rising or falling edges on the A or B ports. During a rising edge, the one-shot turns on the PMOS transistors (T1, T3) for a short duration, which speeds up the low-to-high transition. Similarly, during a falling edge, the one-shot turns on the NMOS transistors (T2, T4) for a short duration, which speeds up the high-to-low transition. The typical output impedance during output transition is 70 Ω at $V_{CCO} = 1.2\text{ V}$ to 1.8 V, 50 Ω at $V_{CCO} = 1.8\text{ V}$ to 3.3 V and 40 Ω at $V_{CCO} = 3.3\text{ V}$ to 5 V.

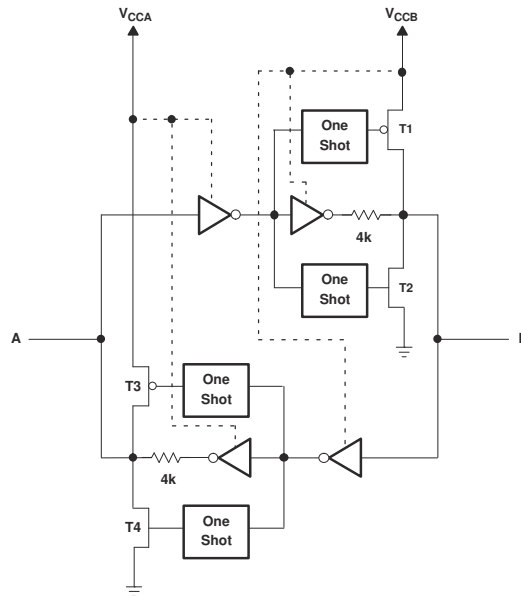

Figure 7-1. Architecture of TXB0108 I/O Cell

7.3.2 Input Driver Requirements

Typical I_{IN} vs V_{IN} characteristics of the TXB0108 are shown in Figure 7-2. For proper operation, the device driving the data I/Os of the TXB0108 must have drive strength of at least $\pm 2\text{ mA}$.

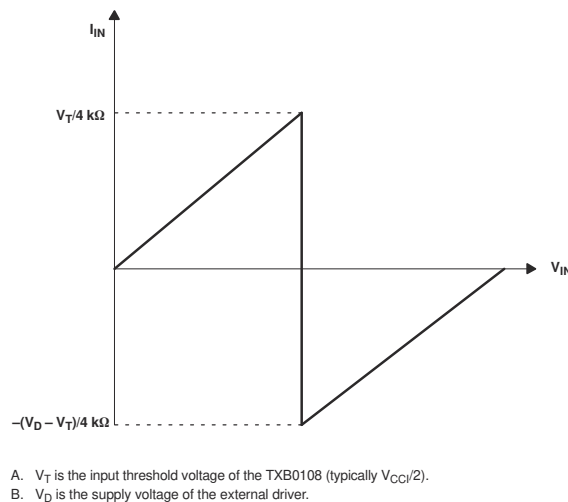

Figure 7-2. Typical I_{IN} vs V_{IN} Curve

7.3.3 Output Load Considerations

TI recommends careful PCB layout practices with short PCB trace lengths to avoid excessive capacitive loading and to ensure that proper O.S. triggering takes place. PCB signal trace-lengths should be kept short enough such that the round-trip delay of any reflection is less than the one-shot duration. This improves signal integrity by ensuring that any reflection sees a low impedance at the driver. The O.S. circuits have been designed to stay on for approximately 10 ns. The maximum capacitance of the lumped load that can be driven also depends directly on the one-shot duration. With very heavy capacitive loads, the one-shot can time-out before the signal is driven fully to the positive rail. The O.S. duration has been set to best optimize trade-offs between dynamic ICC, load driving capability, and maximum bit-rate considerations. Both PCB trace length and connectors add to the capacitance that the TXB0108 output sees, so it is recommended that this lumped-load capacitance be considered to avoid O.S. re-triggering, bus contention, output signal oscillations, or other adverse system-level affects.

7.3.4 Enable and Disable

The TXB0108 has an OE input that is used to disable the device by setting OE = low, which places all I/Os in the high-impedance (Hi-Z) state. The disable time (t_{dis}) indicates the delay between when OE goes low and when the outputs actually get disabled (Hi-Z). The enable time (t_{en}) indicates the amount of time the user must allow for the one-shot circuitry to become operational after the OE is high.

7.3.5 Pullup or Pulldown Resistors on I/O Lines

The TXB0108 is designed to drive capacitive loads of up to 70 pF. The output drivers of the TXB0108 have low dc drive strength. If pullup or pulldown resistors are connected externally to the data I/Os, their values must be kept higher than 50 k Ω to ensure that they do not contend with the output drivers of the TXB0108. For the same reason, the TXB0108 should not be used in applications such as I2C or 1-Wire where an open-drain driver is connected on the bidirectional data I/O. For these applications, use a device from the TI TXS01xx series of level translators.

7.4 Device Functional Modes

The TXB0108 device has two functional modes, enabled and disabled. To disable the device, set the OE input low, which places all I/Os in a high impedance state. Setting the OE input high will enable the device.

8 Application and Implementation

Note

Information in the following applications sections is not part of the TI component specification, and TI does not warrant its accuracy or completeness. TI's customers are responsible for determining suitability of components for their purposes, as well as validating and testing their design implementation to confirm system functionality.

8.1 Application Information

The TXB0108 can be used in level-translation applications for interfacing devices or systems operating at different interface voltages with one another. It can only translate push-pull CMOS logic outputs. If for open-drain signal translation, please refer to TI TXS010X products. Any external pulldown or pullup resistors are recommended to be larger than 50kΩ.

8.2 Typical Application

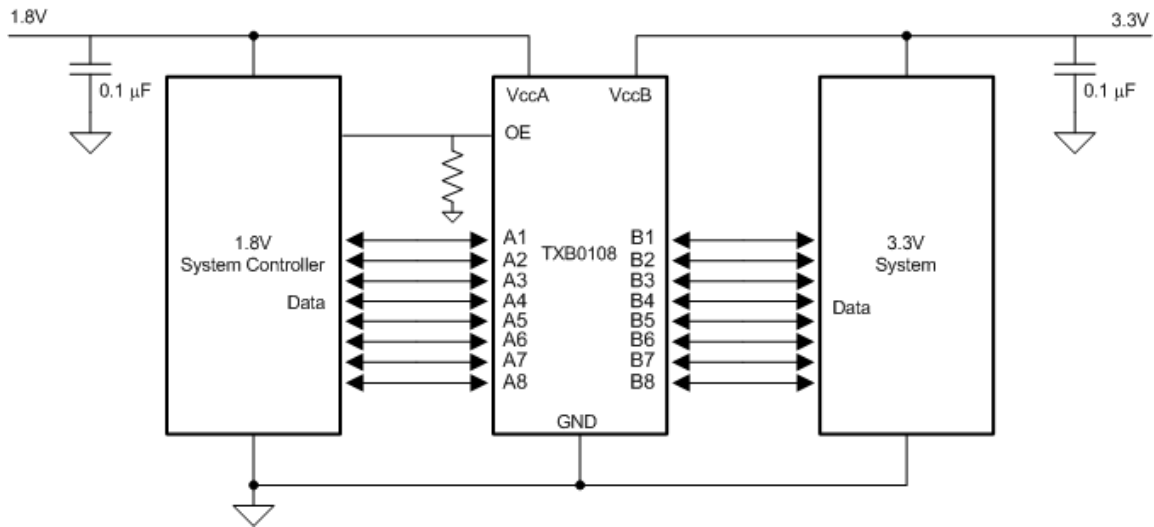

Figure 8-1. Typical Operating Circuit

8.2.1 Design Requirements

For this design example, use the parameters listed in [Table 8-1](#). Make sure the $V_{CCA} \leq V_{CCB}$.

Table 8-1. Design Parameters

DESIGN PARAMETER	EXAMPLE VALUE
Input voltage range	1.2 V to 3.6 V
Output voltage range	1.65 V to 5.5 V

8.2.2 Detailed Design Procedure

To begin the design process, determine the following:

- Input voltage range
 - Use the supply voltage of the device that is driving the TXB0108 device to determine the input voltage range. For a valid logic high the value must exceed the V_{IH} of the input port. For a valid logic low, the value must be less than the V_{IL} of the input port.
- Output voltage range

TXB0108

SCES643I – NOVEMBER 2006 – REVISED DECEMBER 2024

- Use the supply voltage of the device that the TXB0108 device is driving to determine the output voltage range.
- Do not recommend having the external pullup or pulldown resistors. If mandatory, it is recommended the value should be larger than 50 kΩ.
- An external pulldown or pullup resistor decreases the output V_{OH} and V_{OL} . Use the below equations to draft estimate the V_{OH} and V_{OL} as a result of an external pulldown and pullup resistor.

$$V_{OH} = V_{CCx} \times R_{PD} / (R_{PD} + 4.5 \text{ k}\Omega)$$

$$V_{OL} = V_{CCx} \times 4.5\text{k}\Omega / (R_{PU} + 4.5 \text{ k}\Omega)$$

Where:

- V_{CCx} is the output port supply voltage on either VCCA or VCCB
- R_{PD} is the value of the external pull down resistor
- R_{PU} is the value of the external pull up resistor
- 4.5 kΩ is the counting the variation of the serial resistor 4 kΩ in the I/O line. Refer to the [Effects of external pullup and pulldown resistors on TXB](#) application note

8.2.3 Application Curves

ADVANCE INFORMATION

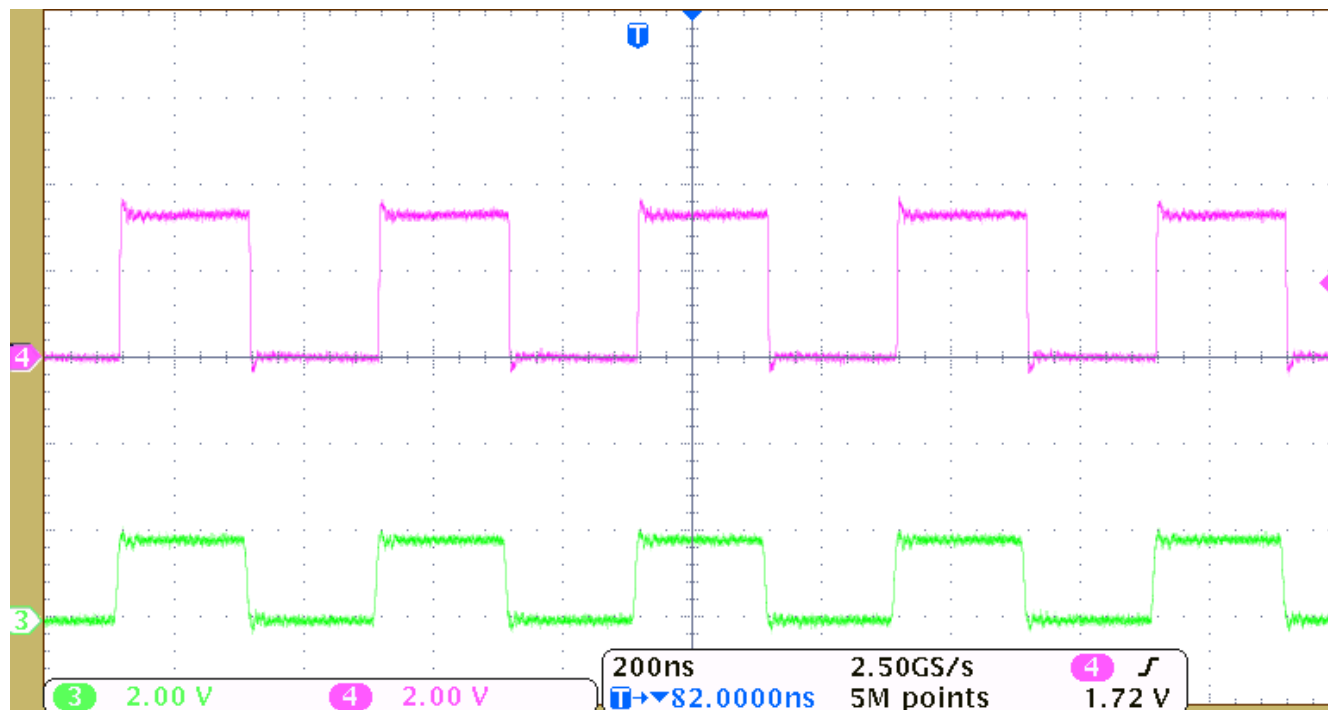

Figure 8-2. Level-Translation of a 2.5-MHz Signal

9 Power Supply Recommendations

During operation, ensure that $V_{CCA} \leq V_{CCB}$ at all times. During power-up sequencing, $V_{CCA} \geq V_{CCB}$ does not damage the device, so any power supply can be ramped up first. The TXB0108-Q1 has circuitry that disables all output ports when either VCC is switched off ($V_{CCA/B} = 0\text{ V}$).

The output-enable (OE) input circuit is designed so that it is supplied by V_{CCA} and when the (OE) input is low, all outputs are placed in the high-impedance state. To ensure the high-impedance state of the outputs during power-up or power-down, the OE input pin must be tied to GND through a pulldown resistor and must not be enabled until V_{CCA} and V_{CCB} are fully ramped and stable. The minimum value of the pulldown resistor to ground is determined by the current-sourcing capability of the driver.

10 Layout

10.1 Layout Guidelines

To ensure reliability of the device, the following common printed-circuit board layout guidelines is recommended.

- Bypass capacitors should be used on power supplies and should be placed as close as possible to the V_{CCA} , V_{CCB} pin and GND pin.
- Short trace lengths should be used to avoid excessive loading.
- PCB signal trace-lengths must be kept short enough so that the round-trip delay of any reflection is less than the one-shot duration, approximately 10 ns, ensuring that any reflection encounters low impedance at the source driver.

10.2 Layout Example

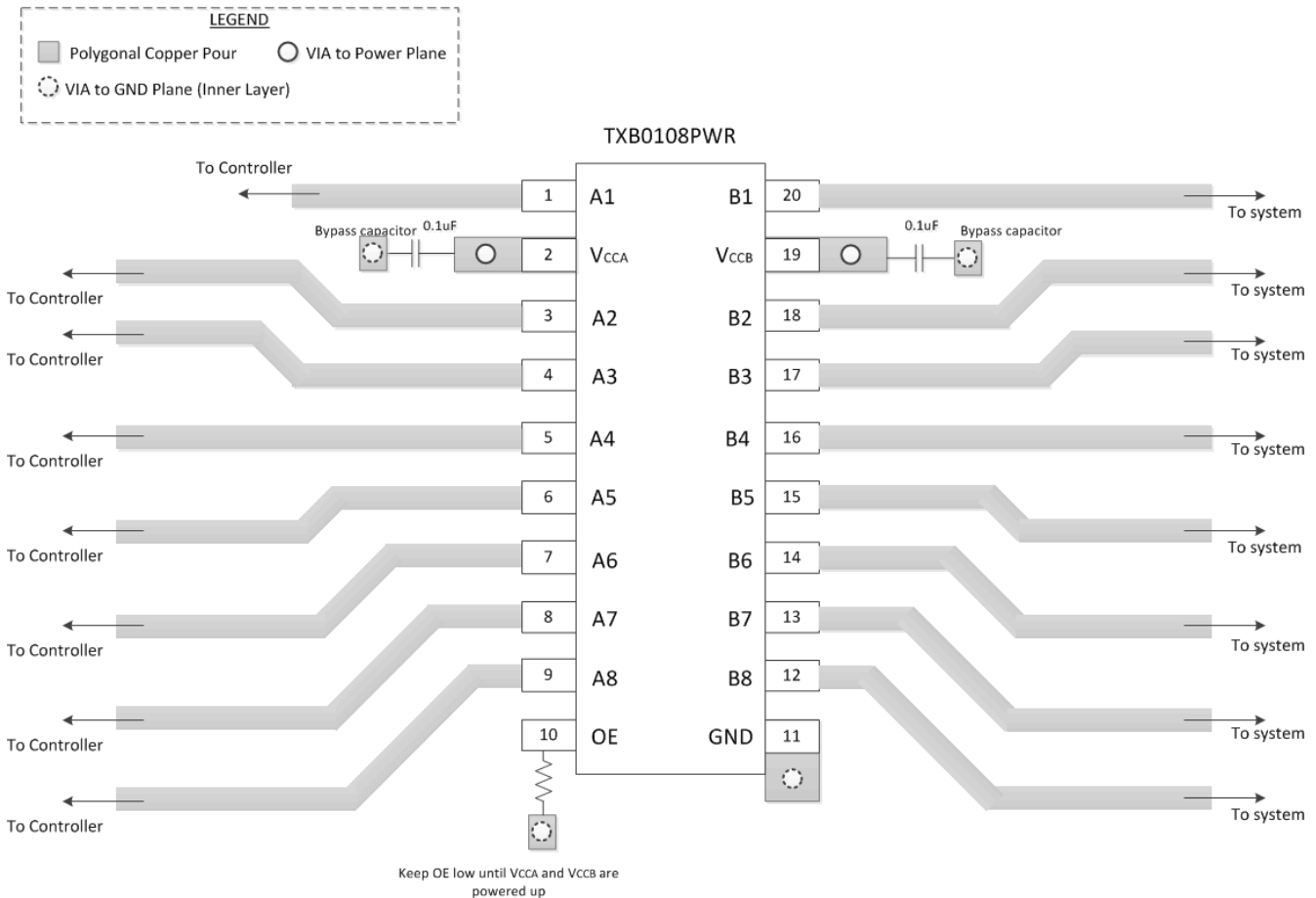

11 Device and Documentation Support

11.1 Receiving Notification of Documentation Updates

To receive notification of documentation updates, navigate to the device product folder on ti.com. Click on *Notifications* to register and receive a weekly digest of any product information that has changed. For change details, review the revision history included in any revised document.

11.2 Support Resources

[TI E2E™ support forums](#) are an engineer's go-to source for fast, verified answers and design help — straight from the experts. Search existing answers or ask your own question to get the quick design help you need.

Linked content is provided "AS IS" by the respective contributors. They do not constitute TI specifications and do not necessarily reflect TI's views; see TI's [Terms of Use](#).

11.3 Trademarks

TI E2E™ is a trademark of Texas Instruments.

All trademarks are the property of their respective owners.

11.4 Electrostatic Discharge Caution



This integrated circuit can be damaged by ESD. Texas Instruments recommends that all integrated circuits be handled with appropriate precautions. Failure to observe proper handling and installation procedures can cause damage.

ESD damage can range from subtle performance degradation to complete device failure. Precision integrated circuits may be more susceptible to damage because very small parametric changes could cause the device not to meet its published specifications.

11.5 Glossary

[TI Glossary](#) This glossary lists and explains terms, acronyms, and definitions.

12 Revision History

NOTE: Page numbers for previous revisions may differ from page numbers in the current version.

Changes from Revision H (August 2020) to Revision I (December 2024) Page

- Added RUK package option to *Device Information* table..... 1

Changes from Revision G (December 2018) to Revision H (August 2020) Page

- Updated the numbering format for tables, figures and cross-references throughout the document..... 1
- Added NME package option to *Device Information* table..... 1
- Added NME package to *Pin Assignments* table..... 3
- Added NME package to *Thermal Information* table..... 6

Changes from Revision F (November 2014) to Revision G (December 2018) Page

- Added pinout image for the ZYPR2 package option 3
- Added text string 'GRID LOCATOR' to Pin Functions table YZP column to clarify pin location from 'Signal Name' 3

Changes from Revision E (April 2012) to Revision F (October 2014) Page

- Added *Pin Configuration and Functions* section, *Handling Rating* table, *Feature Description* section, *Device Functional Modes, Application and Implementation* section, *Power Supply Recommendations* section, *Layout* section, *Device and Documentation Support* section, and *Mechanical, Packaging, and Orderable Information* section 1
- Changed V_{OLA} value 0.9 to 0.3 6

Changes from Revision D (September 2011) to Revision E (April 2012) Page

- Added notes to pin out graphics..... 3

Changes from Revision C (August 2011) to Revision D (September 2011) Page

- Added ± 8 -kV Human-Body Model (A114-B) (YZP Package Only) to Features..... 1

13 Mechanical, Packaging, and Orderable Information

The following pages include mechanical, packaging, and orderable information. This information is the most current data available for the designated devices. This data is subject to change without notice and revision of this document. For browser-based versions of this data sheet, refer to the left-hand navigation.

TXB0108

SCES643I – NOVEMBER 2006 – REVISED DECEMBER 2024

13.1 Package Addendum

13.1.1 Tape and Reel Information

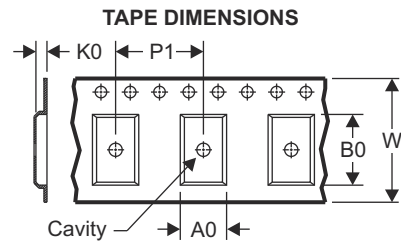
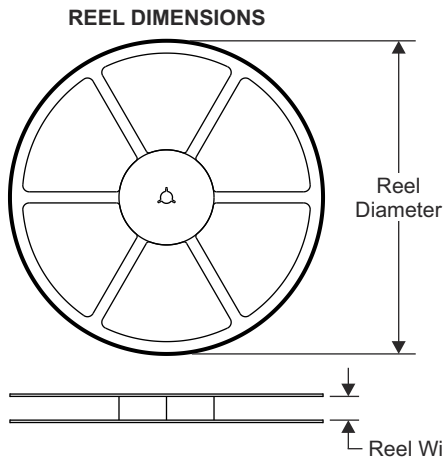

A0	Dimension designed to accommodate the component width
B0	Dimension designed to accommodate the component length
K0	Dimension designed to accommodate the component thickness
W	Overall width of the carrier tape
P1	Pitch between successive cavity centers

QUADRANT ASSIGNMENTS FOR PIN 1 ORIENTATION IN TAPE

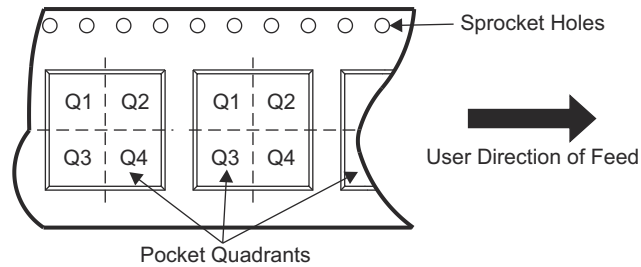

*All dimensions are nominal

Device	Package Type	Package Drawing	Pins	SPQ	Reel Diameter (mm)	Reel Width W1 (mm)	A0 (mm)	B0 (mm)	K0 (mm)	P1 (mm)	W (mm)	Pin1 Quadrant
TXB0108DQSR	USON	DQS	20	3000	177.8	12.4	2.21	4.22	0.81	4.0	12.0	Q1
TXB0108RGYR	VQFN	RGY	20	3000	330.0	12.4	3.8	4.8	1.6	8.0	12.0	Q1
TXB0108YZPR	DSBGA	YZP	20	3000	180.0	8.4	1.99	2.49	0.56	4.0	8.0	Q1
TXB0108YZPR2	DSBGA	YZP	20	3000	180.0	8.4	1.99	2.49	0.56	4.0	8.0	Q2
TXB0108ZXYR	BGA MICROSTAR JUNIOR	ZXY	20	2500	330.0	12.4	2.8	4.22	3.3	1.0	12.0	Q2

ADVANCE INFORMATION

TAPE AND REEL BOX DIMENSIONS



Device	Package Type	Package Drawing	Pins	SPQ	Length (mm)	Width (mm)	Height (mm)
TXB0108DQSR	USON	DQS	20	3000	202.0	201.0	28.0
TXB0108RGYR	VQFN	RGY	20	3000	355.0	350.0	50.0
TXB0108YZPR	DSBGA	YZP	20	3000	182.0	182.0	20.0
TXB0108YZPR2	DSBGA	YZP	20	3000	182.0	182.0	20.0
TXB0108ZXZR	BGA MICROSTAR JUNIOR	ZXY	20	2500	336.6	336.6	28.6

ADVANCE INFORMATION

PACKAGING INFORMATION

Orderable Device	Status (1)	Package Type	Package Drawing	Pins	Package Qty	Eco Plan (2)	Lead finish/ Ball material (6)	MSL Peak Temp (3)	Op Temp (°C)	Device Marking (4/5)	Samples
TXB0108DQSR	ACTIVE	USON	DQS	20	3000	RoHS & Green	NIPDAUAG	Level-1-260C-UNLIM	-40 to 85	5MR 5MH	Samples
TXB0108NMER	ACTIVE	NFBGA	NME	20	2500	RoHS & Green	SNAGCU	Level-2-260C-1 YEAR	-40 to 85	29WW	Samples
TXB0108PWR	ACTIVE	TSSOP	PW	20	2000	RoHS & Green	NIPDAU	Level-1-260C-UNLIM	-40 to 85	YE08	Samples
TXB0108PWRG4	ACTIVE	TSSOP	PW	20	2000	RoHS & Green	NIPDAU	Level-1-260C-UNLIM	-40 to 85	YE08	Samples
TXB0108RGYR	ACTIVE	VQFN	RGY	20	3000	RoHS & Green	NIPDAU	Level-2-260C-1 YEAR	-40 to 85	YE08	Samples
TXB0108YZPR	ACTIVE	DSBGA	YZP	20	3000	RoHS & Green	SNAGCU	Level-1-260C-UNLIM	-40 to 85	5M	Samples
TXB0108YZPR2	ACTIVE	DSBGA	YZP	20	3000	RoHS & Green	SNAGCU	Level-1-260C-UNLIM	-40 to 85	EK	Samples
TXB0108ZXYP	OBSOLETE	BGA MICROSTAR JUNIOR	ZXY	20		TBD	Call TI	Call TI	-40 to 85		

(1) The marketing status values are defined as follows:

ACTIVE: Product device recommended for new designs.

LIFEBUY: TI has announced that the device will be discontinued, and a lifetime-buy period is in effect.

NRND: Not recommended for new designs. Device is in production to support existing customers, but TI does not recommend using this part in a new design.

PREVIEW: Device has been announced but is not in production. Samples may or may not be available.

OBSOLETE: TI has discontinued the production of the device.

(2) **RoHS:** TI defines "RoHS" to mean semiconductor products that are compliant with the current EU RoHS requirements for all 10 RoHS substances, including the requirement that RoHS substance do not exceed 0.1% by weight in homogeneous materials. Where designed to be soldered at high temperatures, "RoHS" products are suitable for use in specified lead-free processes. TI may reference these types of products as "Pb-Free".

RoHS Exempt: TI defines "RoHS Exempt" to mean products that contain lead but are compliant with EU RoHS pursuant to a specific EU RoHS exemption.

Green: TI defines "Green" to mean the content of Chlorine (Cl) and Bromine (Br) based flame retardants meet JS709B low halogen requirements of <=1000ppm threshold. Antimony trioxide based flame retardants must also meet the <=1000ppm threshold requirement.

(3) MSL, Peak Temp. - The Moisture Sensitivity Level rating according to the JEDEC industry standard classifications, and peak solder temperature.

(4) There may be additional marking, which relates to the logo, the lot trace code information, or the environmental category on the device.

⁽⁵⁾ Multiple Device Markings will be inside parentheses. Only one Device Marking contained in parentheses and separated by a "~" will appear on a device. If a line is indented then it is a continuation of the previous line and the two combined represent the entire Device Marking for that device.

⁽⁶⁾ Lead finish/Ball material - Orderable Devices may have multiple material finish options. Finish options are separated by a vertical ruled line. Lead finish/Ball material values may wrap to two lines if the finish value exceeds the maximum column width.

Important Information and Disclaimer:The information provided on this page represents TI's knowledge and belief as of the date that it is provided. TI bases its knowledge and belief on information provided by third parties, and makes no representation or warranty as to the accuracy of such information. Efforts are underway to better integrate information from third parties. TI has taken and continues to take reasonable steps to provide representative and accurate information but may not have conducted destructive testing or chemical analysis on incoming materials and chemicals. TI and TI suppliers consider certain information to be proprietary, and thus CAS numbers and other limited information may not be available for release.

In no event shall TI's liability arising out of such information exceed the total purchase price of the TI part(s) at issue in this document sold by TI to Customer on an annual basis.

TAPE AND REEL INFORMATION

QUADRANT ASSIGNMENTS FOR PIN 1 ORIENTATION IN TAPE



*All dimensions are nominal

Device	Package Type	Package Drawing	Pins	SPQ	Reel Diameter (mm)	Reel Width W1 (mm)	A0 (mm)	B0 (mm)	K0 (mm)	P1 (mm)	W (mm)	Pin1 Quadrant
TXB0108DQSR	USON	DQS	20	3000	177.8	12.4	2.21	4.22	0.81	4.0	12.0	Q1
TXB0108NMER	NFBGA	NME	20	2500	330.0	12.4	2.85	3.4	1.34	4.0	12.0	Q2
TXB0108PWR	TSSOP	PW	20	2000	330.0	16.4	6.95	7.0	1.4	8.0	16.0	Q1
TXB0108RGYR	VQFN	RGY	20	3000	330.0	12.4	3.8	4.8	1.6	8.0	12.0	Q1
TXB0108YZPR	DSBGA	YZP	20	3000	180.0	8.4	1.99	2.49	0.56	4.0	8.0	Q1
TXB0108YZPR2	DSBGA	YZP	20	3000	180.0	8.4	1.99	2.49	0.56	4.0	8.0	Q2

TAPE AND REEL BOX DIMENSIONS

*All dimensions are nominal

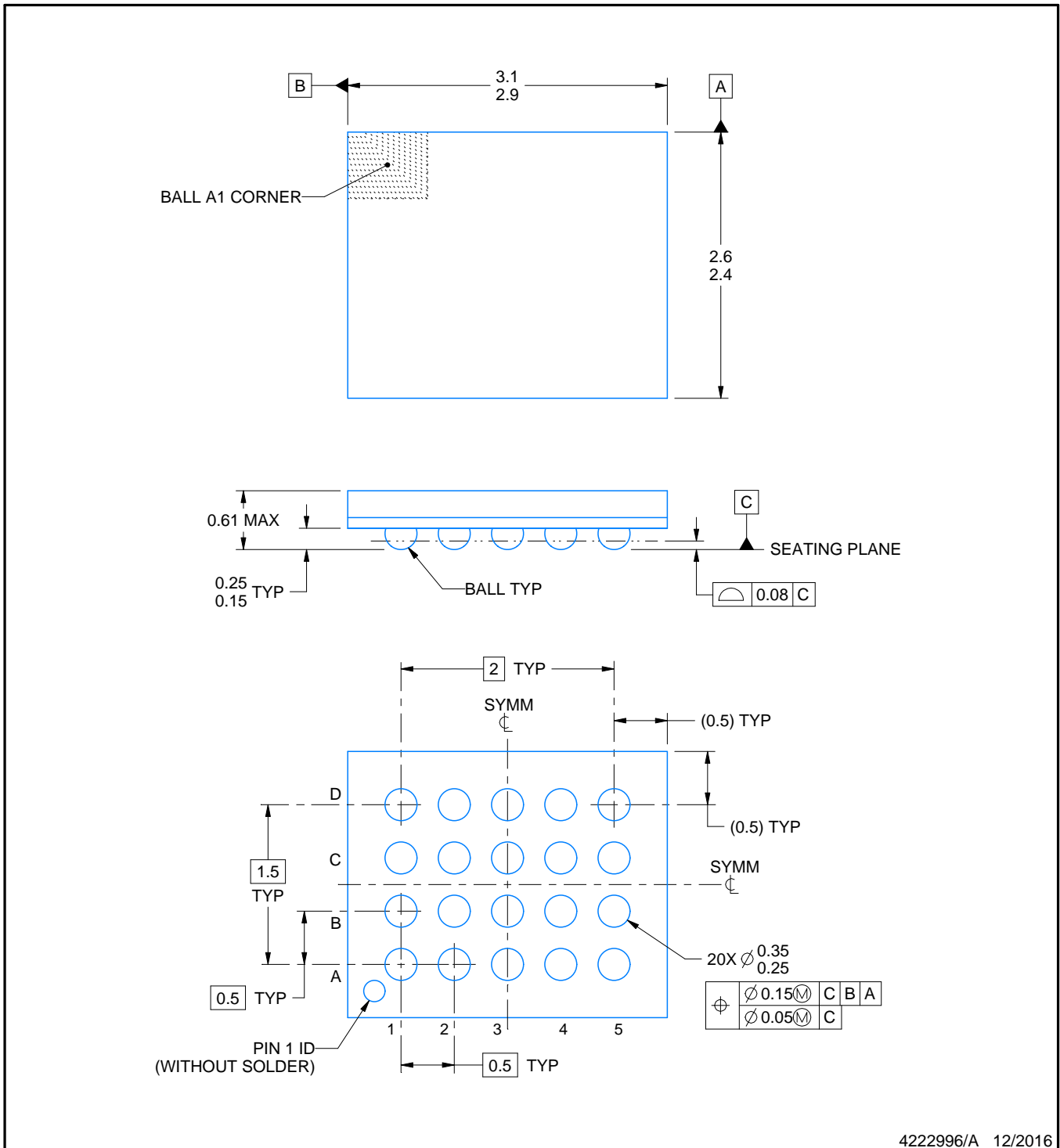
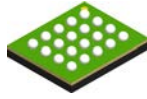
Device	Package Type	Package Drawing	Pins	SPQ	Length (mm)	Width (mm)	Height (mm)
TXB0108DQSR	USON	DQS	20	3000	202.0	201.0	28.0
TXB0108NMER	NFBGA	NME	20	2500	336.6	336.6	31.8
TXB0108PWR	TSSOP	PW	20	2000	356.0	356.0	35.0
TXB0108RGYR	VQFN	RGY	20	3000	356.0	356.0	35.0
TXB0108YZPR	DSBGA	YZP	20	3000	182.0	182.0	20.0
TXB0108YZPR2	DSBGA	YZP	20	3000	182.0	182.0	20.0



4222996/A 12/2016

NOTES:

1. All linear dimensions are in millimeters. Any dimensions in parenthesis are for reference only. Dimensioning and tolerancing per ASME Y14.5M.
2. This drawing is subject to change without notice.

EXAMPLE BOARD LAYOUT

ZXY0020A

VFBGA - 0.61 mm max height

PLASTIC BALL GRID ARRAY

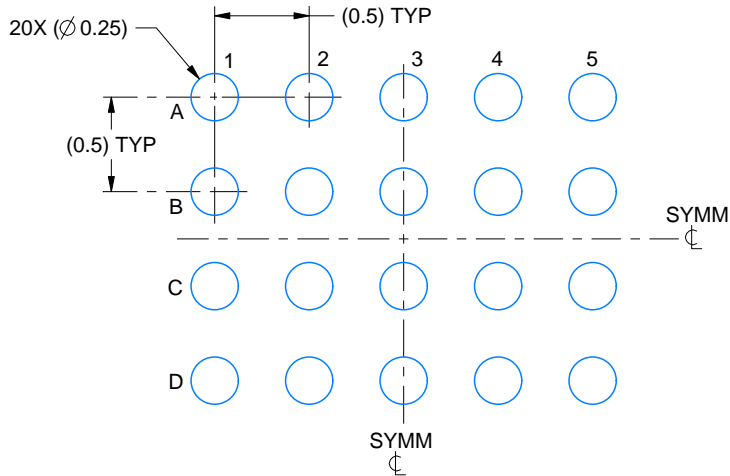

LAND PATTERN EXAMPLE
EXPOSED METAL SHOWN
SCALE:25X

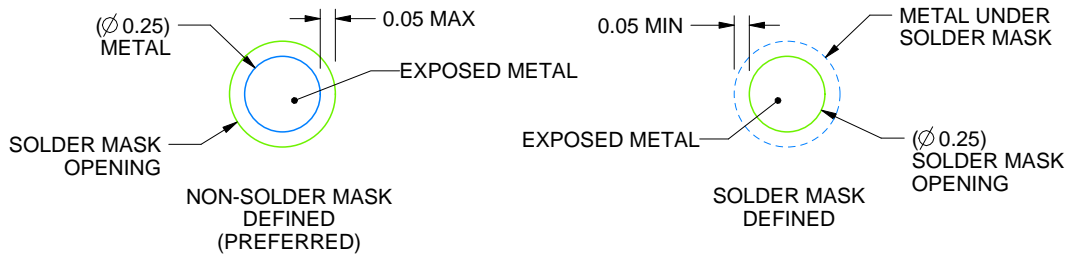

SOLDER MASK DETAILS
NOT TO SCALE

4222996/A 12/2016

NOTES: (continued)

- Final dimensions may vary due to manufacturing tolerance considerations and also routing constraints. For information, see Texas Instruments literature number SPRAA99 (www.ti.com/lit/spraa99).

EXAMPLE STENCIL DESIGN

ZXY0020A

VFBGA - 0.61 mm max height

PLASTIC BALL GRID ARRAY

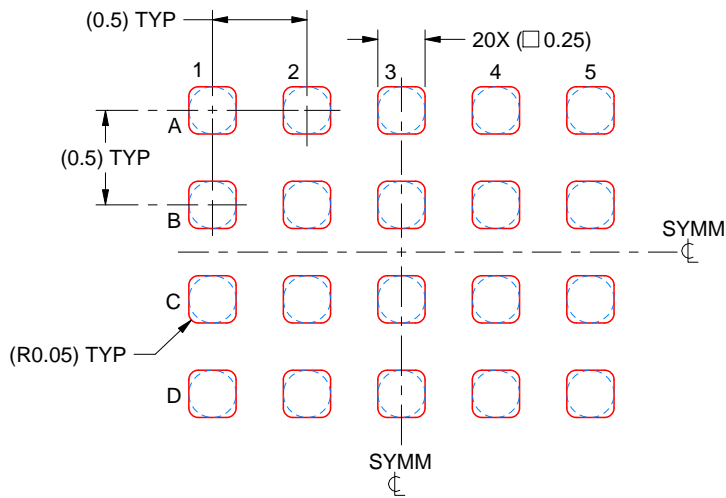

SOLDER PASTE EXAMPLE
BASED ON 0.1 mm THICK STENCIL
SCALE: 25X

4222996/A 12/2016

NOTES: (continued)

4. Laser cutting apertures with trapezoidal walls and rounded corners may offer better paste release.



NOTES:

1. All linear dimensions are in millimeters. Any dimensions in parenthesis are for reference only. Dimensioning and tolerancing per ASME Y14.5M.
2. This drawing is subject to change without notice.
3. This dimension does not include mold flash, protrusions, or gate burrs. Mold flash, protrusions, or gate burrs shall not exceed 0.15 mm per side.
4. This dimension does not include interlead flash. Interlead flash shall not exceed 0.25 mm per side.
5. Reference JEDEC registration MO-153.

EXAMPLE BOARD LAYOUT

PW0020A

TSSOP - 1.2 mm max height

SMALL OUTLINE PACKAGE



LAND PATTERN EXAMPLE
EXPOSED METAL SHOWN
SCALE: 10X



SOLDER MASK DETAILS

4220206/A 02/2017

NOTES: (continued)

- 6. Publication IPC-7351 may have alternate designs.
- 7. Solder mask tolerances between and around signal pads can vary based on board fabrication site.

EXAMPLE STENCIL DESIGN

PW0020A

TSSOP - 1.2 mm max height

SMALL OUTLINE PACKAGE



SOLDER PASTE EXAMPLE
BASED ON 0.125 mm THICK STENCIL
SCALE: 10X

4220206/A 02/2017

NOTES: (continued)

8. Laser cutting apertures with trapezoidal walls and rounded corners may offer better paste release. IPC-7525 may have alternate design recommendations.
9. Board assembly site may have different recommendations for stencil design.

DQS (R-PUSON-N20)

PLASTIC SMALL OUTLINE NO-LEAD

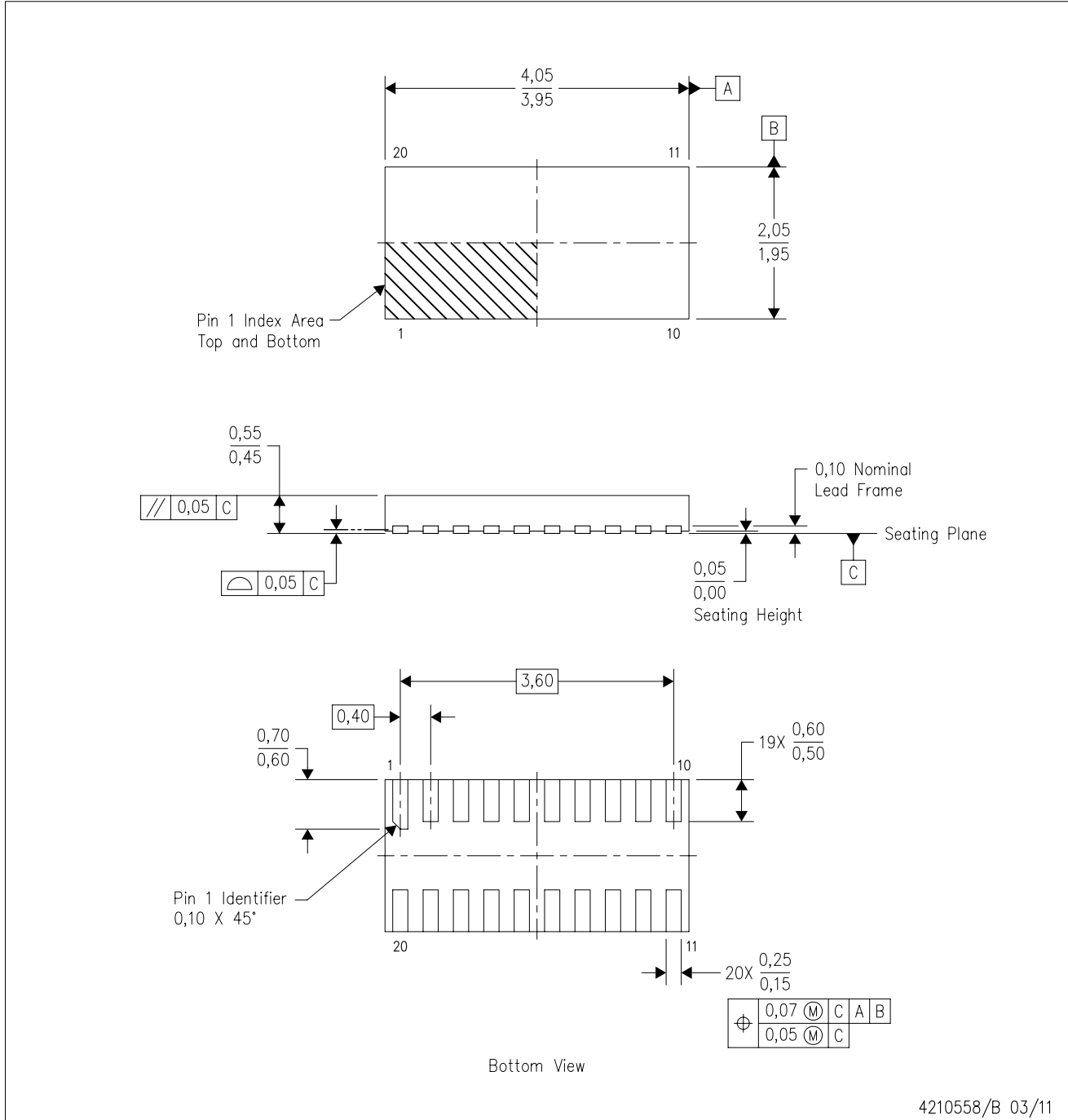

- NOTES:
- A. All linear dimensions are in millimeters. Dimensioning and tolerancing per ASME Y14.5M-1994.
 - B. This drawing is subject to change without notice.
 - C. SON (Small Outline No-Lead) package configuration.

DQS (R-PUSON-N20)

PLASTIC SMALL OUTLINE NO-LEAD

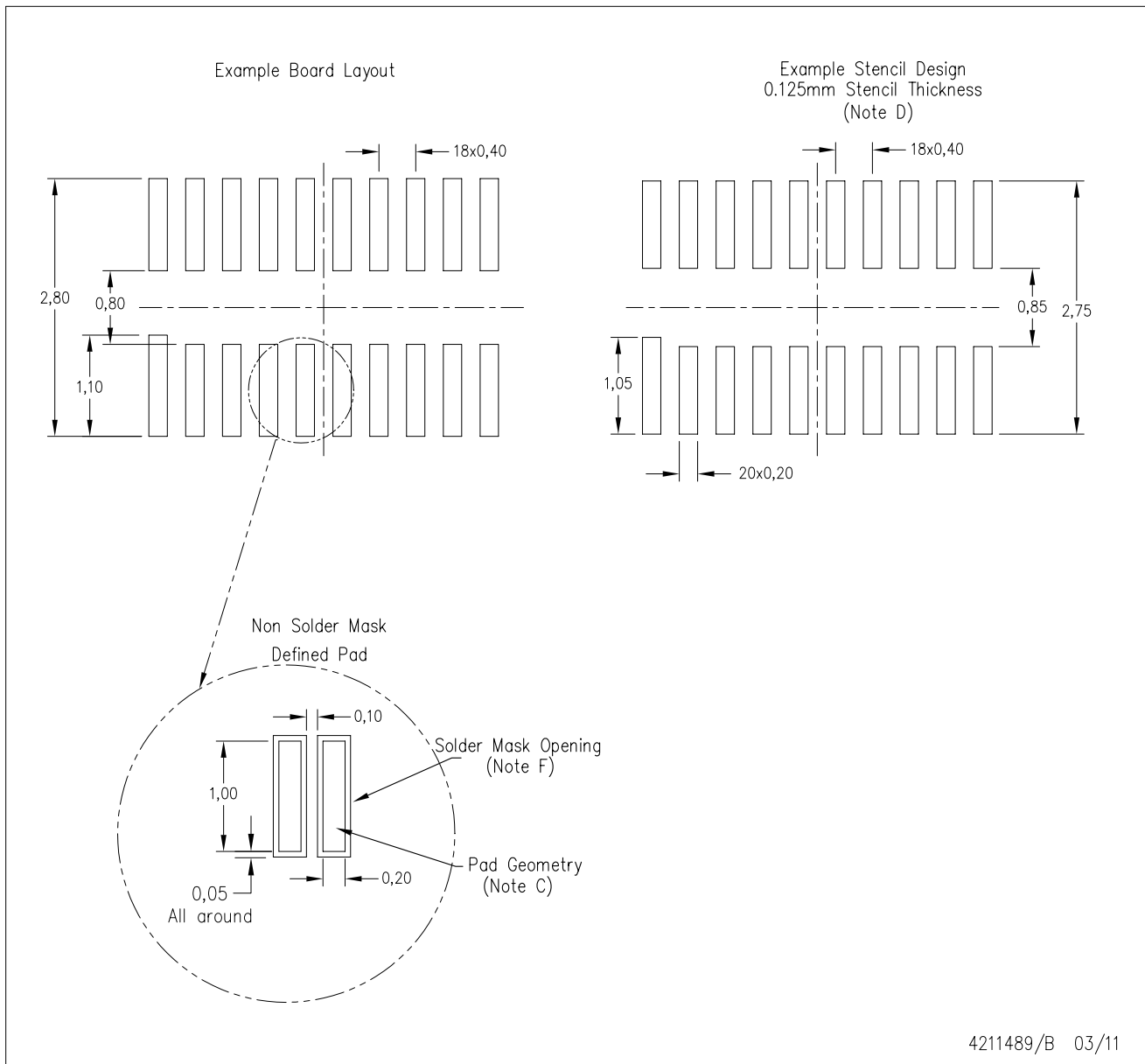

- NOTES:
- All linear dimensions are in millimeters.
 - This drawing is subject to change without notice.
 - Publication IPC-7351 is recommended for alternate designs.
 - Laser cutting apertures with trapezoidal walls and also rounding corners will offer better paste release. Customers should contact their board assembly site for stencil design recommendations. Refer to IPC 7525 for stencil design considerations.
 - Customers should contact their board fabrication site for minimum solder mask web tolerances between signal pads.

YZP (R-XBGA-N20)

DIE-SIZE BALL GRID ARRAY

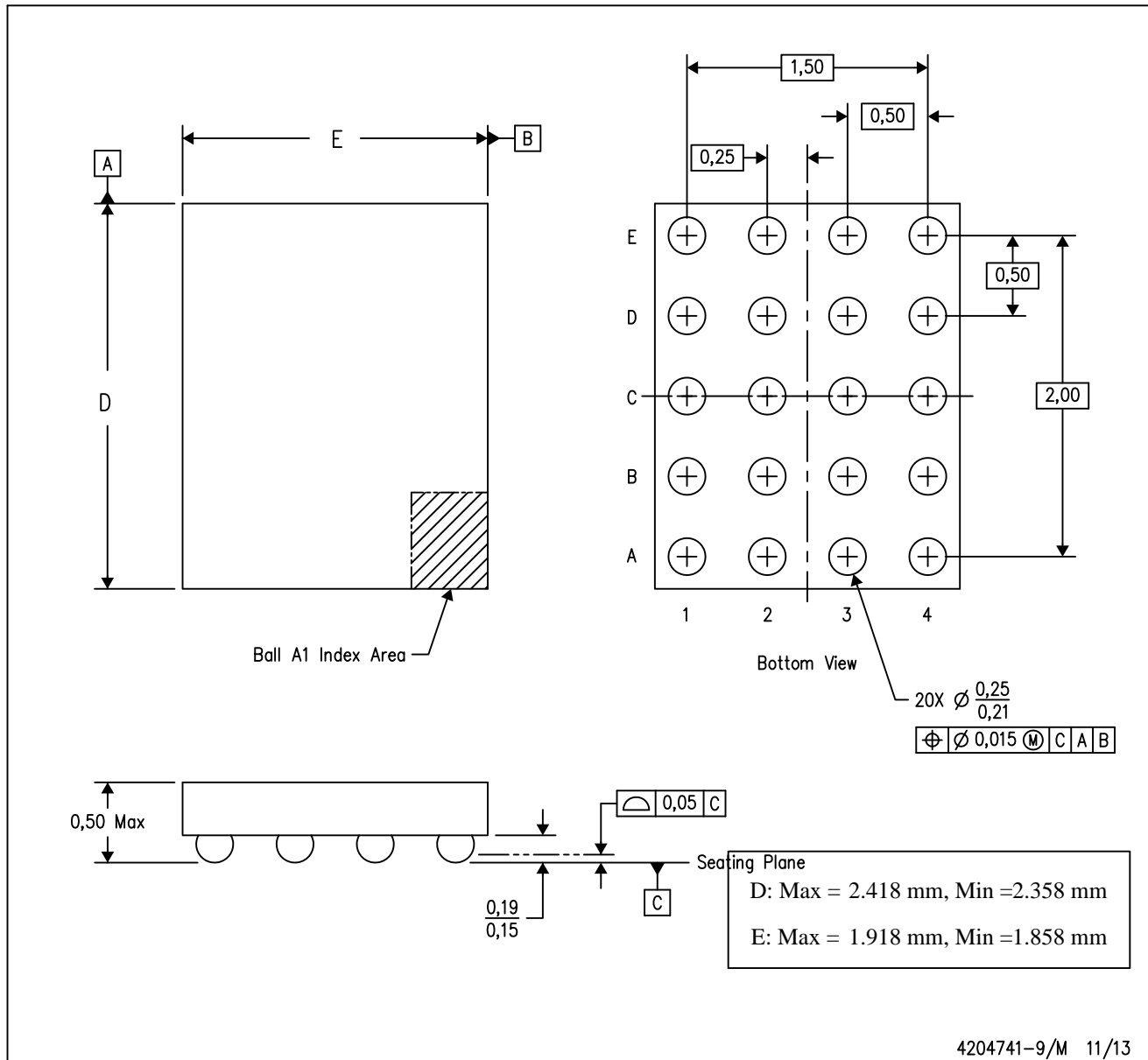

- NOTES:
- A. All linear dimensions are in millimeters. Dimensioning and tolerancing per ASME Y14.5M-1994.
 - B. This drawing is subject to change without notice.
 - C. NanoFree™ package configuration.

NanoFree is a trademark of Texas Instruments.

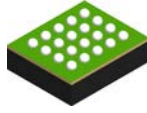

NME0020A

PACKAGE OUTLINE

NFBGA - 1 mm max height

PLASTIC BALL GRID ARRAY

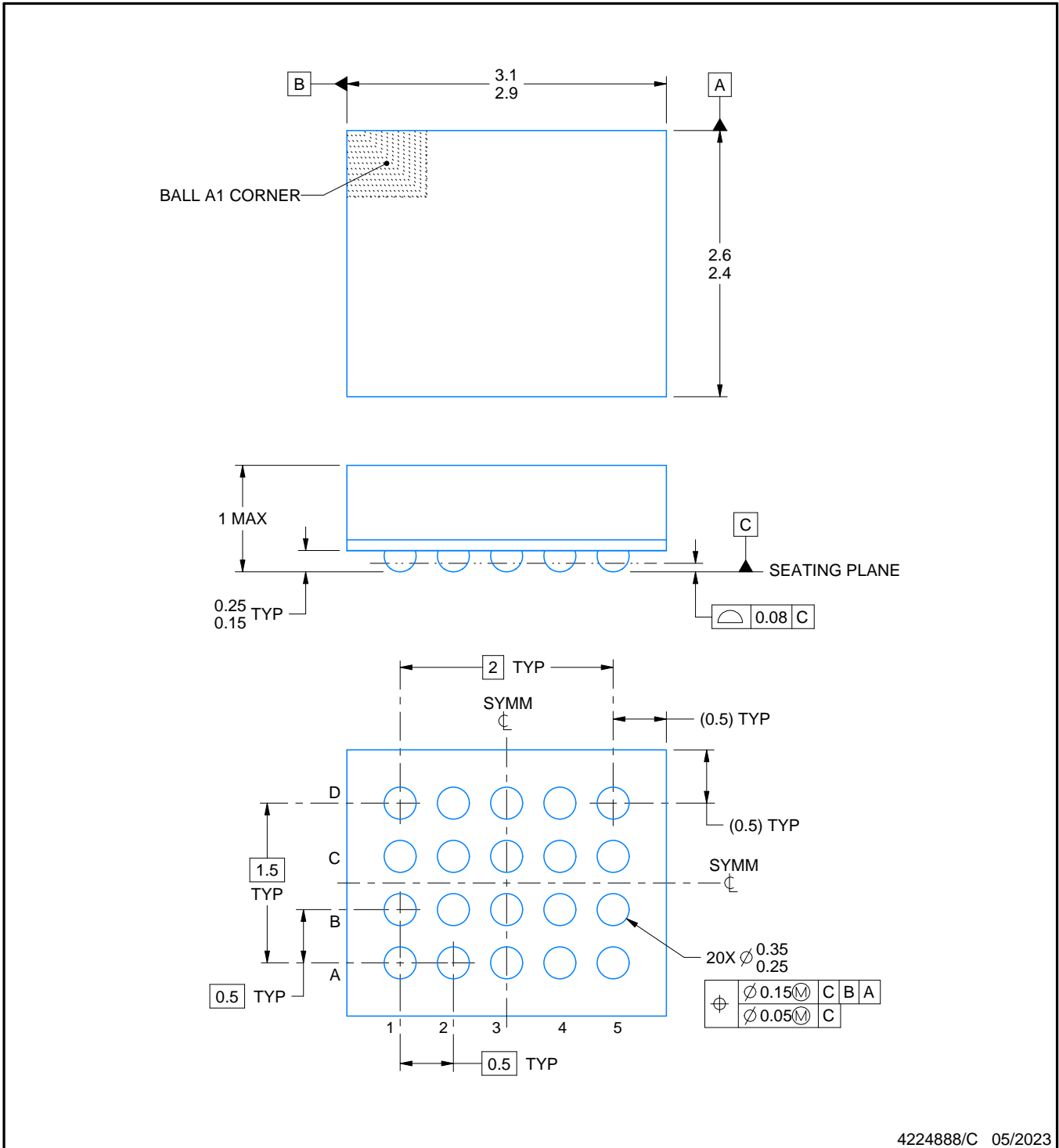

4224888/C 05/2023

NOTES:

1. All linear dimensions are in millimeters. Any dimensions in parenthesis are for reference only. Dimensioning and tolerancing per ASME Y14.5M.
2. This drawing is subject to change without notice.

EXAMPLE BOARD LAYOUT

NME0020A

NFBGA - 1 mm max height

PLASTIC BALL GRID ARRAY

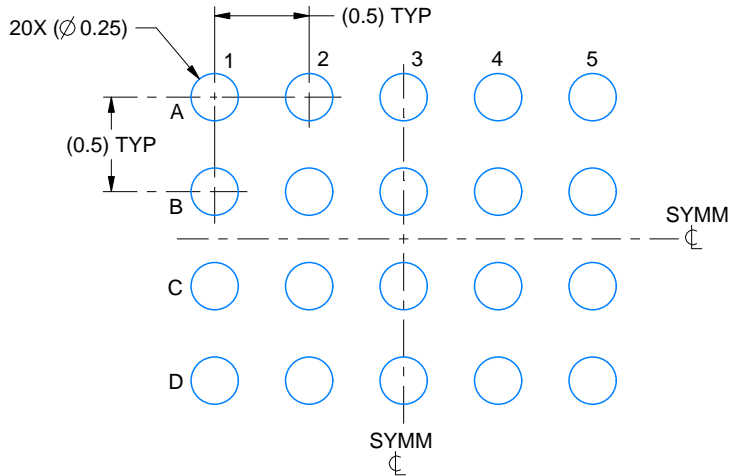

LAND PATTERN EXAMPLE
EXPOSED METAL SHOWN
SCALE:25X

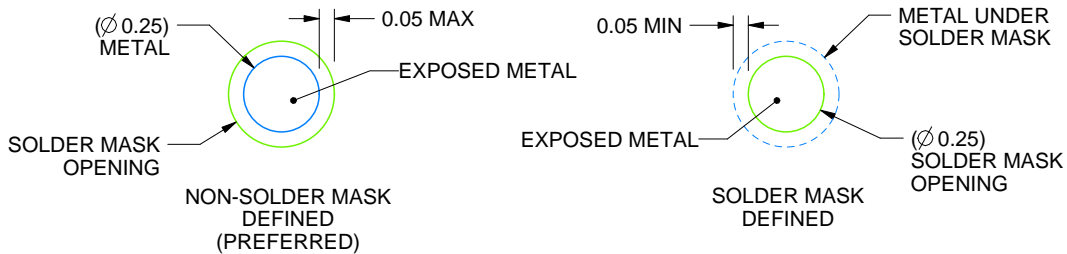

SOLDER MASK DETAILS
NOT TO SCALE

4224888/C 05/2023

NOTES: (continued)

- Final dimensions may vary due to manufacturing tolerance considerations and also routing constraints. For information, see Texas Instruments literature number SPRAA99 (www.ti.com/lit/spraa99).

EXAMPLE STENCIL DESIGN

NME0020A

NFBGA - 1 mm max height

PLASTIC BALL GRID ARRAY

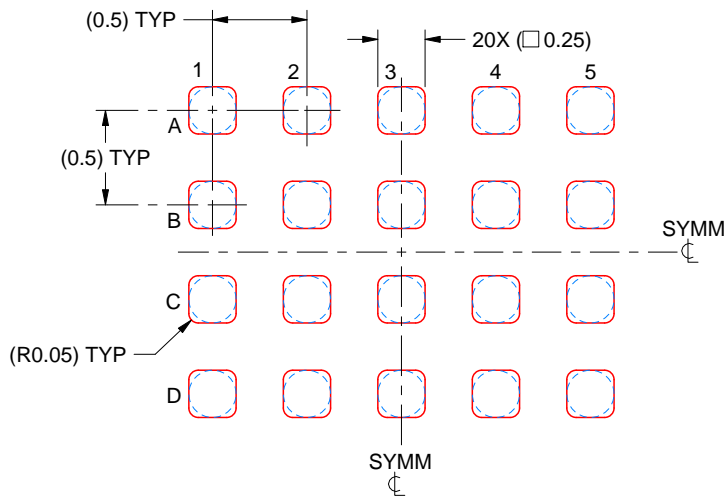

SOLDER PASTE EXAMPLE
BASED ON 0.1 mm THICK STENCIL
SCALE: 25X

4224888/C 05/2023

NOTES: (continued)

4. Laser cutting apertures with trapezoidal walls and rounded corners may offer better paste release.

GENERIC PACKAGE VIEW

RGY 20

VQFN - 1 mm max height

3.5 x 4.5, 0.5 mm pitch

PLASTIC QUAD FGLATPACK - NO LEAD

This image is a representation of the package family, actual package may vary.
Refer to the product data sheet for package details.



4225264/A



4225320/A 09/2019

NOTES:

1. All linear dimensions are in millimeters. Any dimensions in parenthesis are for reference only. Dimensioning and tolerancing per ASME Y14.5M.
2. This drawing is subject to change without notice.
3. The package thermal pad must be soldered to the printed circuit board for thermal and mechanical performance.

EXAMPLE BOARD LAYOUT

RGY0020A

VQFN - 1 mm max height

PLASTIC QUAD FLATPACK - NO LEAD



LAND PATTERN EXAMPLE
EXPOSED METAL SHOWN
SCALE:18X



SOLDER MASK DETAILS

4225320/A 09/2019

NOTES: (continued)

4. This package is designed to be soldered to a thermal pad on the board. For more information, see Texas Instruments literature number SLUA271 (www.ti.com/lit/slua271).
5. Vias are optional depending on application, refer to device data sheet. If any vias are implemented, refer to their locations shown on this view. It is recommended that vias under paste be filled, plugged or tented.

EXAMPLE STENCIL DESIGN

RGY0020A

VQFN - 1 mm max height

PLASTIC QUAD FLATPACK - NO LEAD



SOLDER PASTE EXAMPLE
 BASED ON 0.125 mm THICK STENCIL

EXPOSED PAD 21
 78% PRINTED SOLDER COVERAGE BY AREA UNDER PACKAGE
 SCALE:20X

4225320/A 09/2019

NOTES: (continued)

6. Laser cutting apertures with trapezoidal walls and rounded corners may offer better paste release. IPC-7525 may have alternate design recommendations.

IMPORTANT NOTICE AND DISCLAIMER

TI PROVIDES TECHNICAL AND RELIABILITY DATA (INCLUDING DATA SHEETS), DESIGN RESOURCES (INCLUDING REFERENCE DESIGNS), APPLICATION OR OTHER DESIGN ADVICE, WEB TOOLS, SAFETY INFORMATION, AND OTHER RESOURCES "AS IS" AND WITH ALL FAULTS, AND DISCLAIMS ALL WARRANTIES, EXPRESS AND IMPLIED, INCLUDING WITHOUT LIMITATION ANY IMPLIED WARRANTIES OF MERCHANTABILITY, FITNESS FOR A PARTICULAR PURPOSE OR NON-INFRINGEMENT OF THIRD PARTY INTELLECTUAL PROPERTY RIGHTS.

These resources are intended for skilled developers designing with TI products. You are solely responsible for (1) selecting the appropriate TI products for your application, (2) designing, validating and testing your application, and (3) ensuring your application meets applicable standards, and any other safety, security, regulatory or other requirements.

These resources are subject to change without notice. TI grants you permission to use these resources only for development of an application that uses the TI products described in the resource. Other reproduction and display of these resources is prohibited. No license is granted to any other TI intellectual property right or to any third party intellectual property right. TI disclaims responsibility for, and you will fully indemnify TI and its representatives against, any claims, damages, costs, losses, and liabilities arising out of your use of these resources.

TI's products are provided subject to [TI's Terms of Sale](#) or other applicable terms available either on [ti.com](https://www.ti.com) or provided in conjunction with such TI products. TI's provision of these resources does not expand or otherwise alter TI's applicable warranties or warranty disclaimers for TI products.

TI objects to and rejects any additional or different terms you may have proposed.

Mailing Address: Texas Instruments, Post Office Box 655303, Dallas, Texas 75265
Copyright © 2024, Texas Instruments Incorporated