

## **Multi-Cal-Master Evaluation Module**

This user's guide describes the characteristics, operation, and the use of the Multi-Cal-Master evaluation module (EVM). It covers all pertinent areas involved to properly use this EVM board. The document includes the physical printed circuit board (PCB) layout, schematic diagrams, and circuit descriptions.

### **Contents**

|   |   |    |
|---|---|----|
| 1 | Overview .....  | 2  |
| 2 | Theory of Operation for Multi-Cal-Master EVM Hardware ..... | 4  |
| 3 | Bill of Materials .....                                     | 24 |

### **List of Figures**

|    |   |    |
|----|---|----|
| 1  | Hardware Included with the Multi-Cal-Master EVM Kit .....     | 2  |
| 2  | Multi-Cal-Master System Block Diagram .....                   | 4  |
| 3  | Power Control Logic Circuitry Schematic .....                 | 5  |
| 4  | One-to- $V_{OUT}$ Circuitry Schematic .....                   | 6  |
| 5  | Simplified Gate Connection for and .....                      | 6  |
| 6  | Current Meter Control Circuitry Schematic .....               | 7  |
| 7  | Power Relay Control Circuitry Schematic .....                 | 7  |
| 8  | Control Signal Latch Circuitry Schematic .....                | 9  |
| 9  | SPI Multiplexer Circuitry Schematic.....                      | 10 |
| 10 | One-Wire Signal Multiplexed to Eight Sensor Modules .....     | 11 |
| 11 | Multiplexer for Voltmeter.....                                | 12 |
| 12 | LED Selection Performed by Decoder.....                       | 13 |
| 13 | Ribbon Cable Connection to Multi-Cal-Slave .....              | 14 |
| 14 | Multi-Cal-Master Regulators .....                             | 16 |
| 15 | USB DAQ Platform Connection to Multi-Cal-Master .....         | 17 |
| 16 | Power and DMM Connector Circuitry Schematic .....             | 18 |
| 17 | Power-Supply Overcurrent Protection Circuitry Schematic ..... | 19 |
| 18 | $\pm 15V$ System Connection .....                             | 20 |
| 19 | Sensor Module Connection Circuitry Schematic .....            | 21 |

### **List of Tables**

|   |   |    |
|---|---|----|
| 1 | Power Control Circuitry Operating Modes .....               | 8  |
| 2 | BCT Control Line Functions.....                             | 13 |
| 3 | Slave Ribbon Cable Pins and Functions .....                 | 14 |
| 4 | Signal Definitions for J102 from the USB DAQ Platform ..... | 17 |
| 5 | Signal Definition for J101 from the USB DAQ Platform .....  | 18 |
| 6 | J9 Power and Digital Multimeter Connections .....           | 19 |
| 7 | J0: Signal Connection Summary .....                         | 22 |
| 8 | J1: Signal Connection Summary .....                         | 23 |
| 9 | Multi-Cal-Master EVM Parts List .....                       | 24 |

<sup>1</sup>PC is a trademark of NXP Semiconductors.  
 All other trademarks are the property of their respective owners.

## 1 Overview

The Multi-Cal-Master Evaluation Module is a set of EVMs that is used to calibrate multiple [PGA308 sensor modules](#). The PGA308 is a programmable analog sensor signal conditioner. All components in the Multi-Cal-Master can be expanded to calibrate up to 64 sensors simultaneously. For a more detailed description of the PGA308, refer to the product data sheet ([SBOS440](#)) available from the Texas Instruments web site at <http://www.ti.com>. Additional support documents are listed in the section of this guide entitled [Related Documentation from Texas Instruments](#).

The Multi-Cal-Master Evaluation Module consists of a single PCB. The complete Multi-Cal-System contains a series of PCAs, and can be expanded to meet your specific system requirements.

Throughout this document, the abbreviation *EVM* and the term *evaluation module* are synonymous with the Multi-Cal-Master Evaluation Module.

### 1.1 Multi-Cal-Master Hardware Options

[Figure 1](#) shows the hardware included with the Multi-Cal-Master EVM.

The Multi-Cal-Master EVM generates and multiplexes all the signals required to calibrate the sensor modules. To use this EVM, you will need cables and an interface PCB (sold separately). The Multi-Cal-System User's Guide lists and describes all the elements required to set up the starter system (that is, a basic eight-channel system).

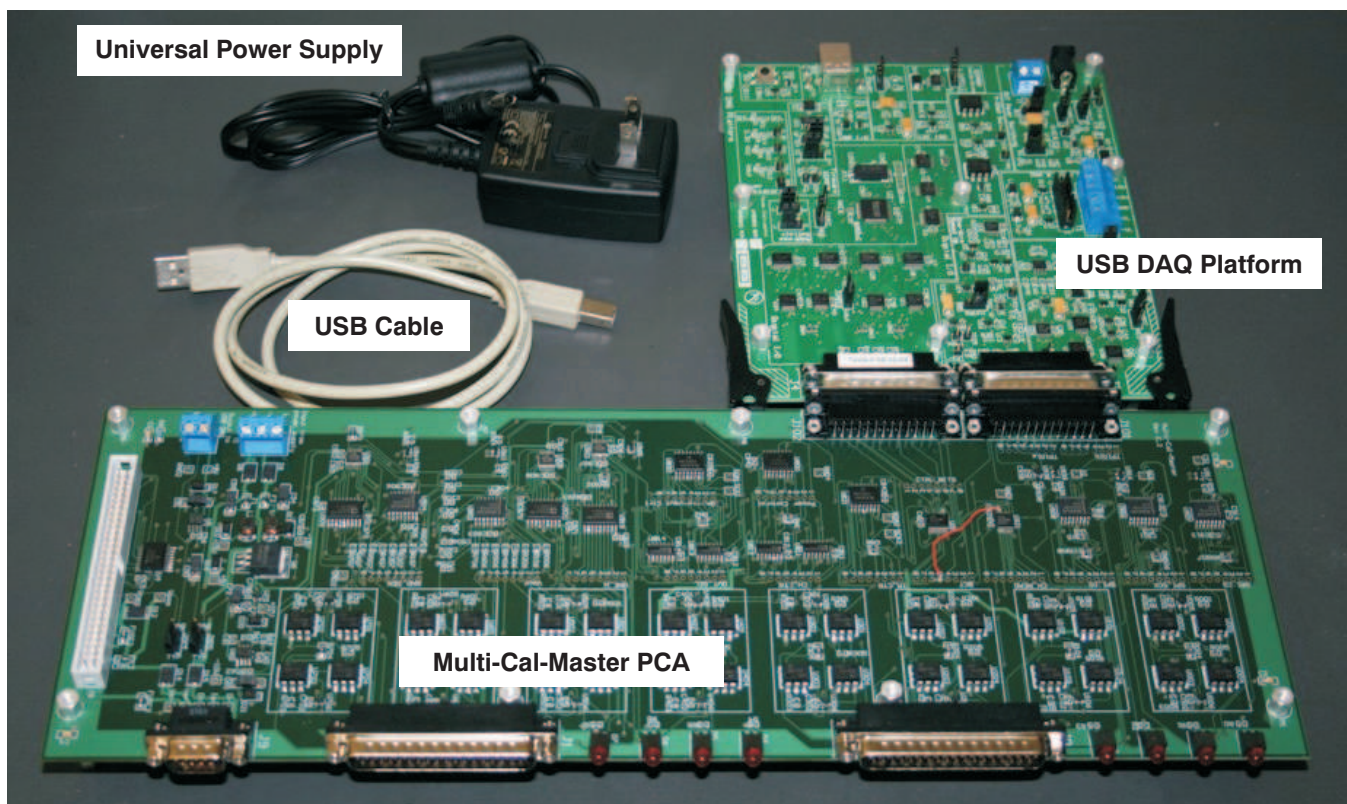

**Figure 1. Hardware Included with the Multi-Cal-Master EVM Kit**

The Multi-Cal-Master EVM kit includes the following items:

- **USB DAQ Platform:** This board connects to the USB port on your computer. It generates all the control signals and communication signals for the Multi-Cal-System.
- **Universal 9V power supply:** 9V<sub>DC</sub>, 220V/120V universal power source. (Adaptors are also provided for most major countries.)
- **USB cable:** Connects your computer to the USB DAQ Platform PCB; it is an A-Male to B-Male USB cable.
- **Multi-Cal-Master:** This board multiplexes all the communication signals, sensor module output signals, and power.

Contact the factory if any component is missing.

## 1.2 Related Documentation from Texas Instruments

The following documents provide information regarding Texas Instruments integrated circuits used in the assembly of the Multi-Cal-Master EVM. This user's guide is available from the TI website under literature number [SBOU089](#). Any letter appended to the literature number corresponds to the document revision that is current at the time of the writing of this document. Newer revisions may be available from the TI web site at <http://www.ti.com/>, or call the Texas Instruments Literature Response Center at (800) 477-8924 or the Product Information Center at (972) 644-5580. When ordering, identify the document by both title and literature number.

| Document                          | Literature Number       |
|-----------------------------------|-------------------------|
| Multi-Cal-Test EVM User's Guide   | <a href="#">SBOU088</a> |
| Multi-Cal-Slave EVM User's Guide  | <a href="#">SBOU094</a> |
| USB DAQ Platform User's Guide     | <a href="#">SBOU056</a> |
| Multi-Cal-System EVM User's Guide | <a href="#">SBOU087</a> |
| Multi-Cal-Cable User's Guide      | <a href="#">SBOU092</a> |
| Multi-Cal-Interface User's Guide  | <a href="#">SBOU093</a> |

## 1.3 Information About Cautions and Warnings

This document contains caution statements.

### CAUTION

This is an example of a caution statement. A caution statement describes a situation that could potentially damage your software or equipment.

The information in a caution or a warning is provided for your protection. Please read each caution carefully.

## 1.4 Applications Questions

If you have questions about this or other Texas Instruments evaluation modules, post a question in the *Amplifiers* forum at <http://e2e.ti.com>. Include in the subject heading the product in which you are interested.

## 2 Theory of Operation for Multi-Cal-Master EVM Hardware

This section discusses the operation of the Multi-Cal-Master EVM hardware.

### 2.1 Electrostatic Discharge Warning

Many of the components on the Multi-Cal-Master are susceptible to damage by electrostatic discharge (ESD). Customers are advised to observe proper ESD handling precautions when unpacking and handling the EVM, including the use of a grounded wrist strap at an approved ESD workstation.

**CAUTION**

Failure to observe ESD handling procedures may result in damage to EVM components.

### 2.2 Multi-Cal-Master

Figure 2 shows the block diagram of the Multi-Cal-Master. The Multi-Cal-Master multiplexes the digital communication signals from the USB DAQ Platform to eight sensor modules. The power supply and output voltage or current signals are also multiplexed.

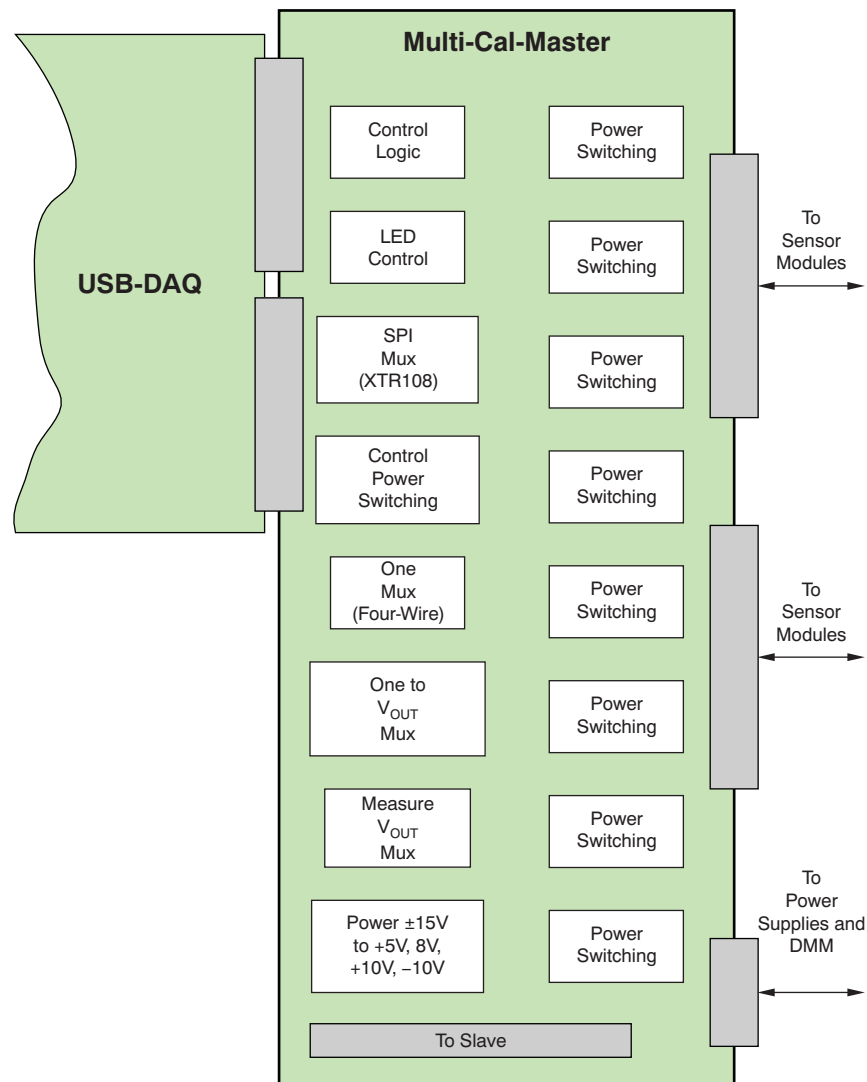

**Figure 2. Multi-Cal-Master System Block Diagram**

### 2.3 Control Schematics

The power supply and reference connections for the Multi-Cal-Master are illustrated in Figure 3. The output of this circuit is CH0\_CTR to CH7\_CTR. These control signals turn the photo MOS relays on and off. U800 is an I<sup>2</sup>C™ port expander (PCF9534) that generates the power control signals.

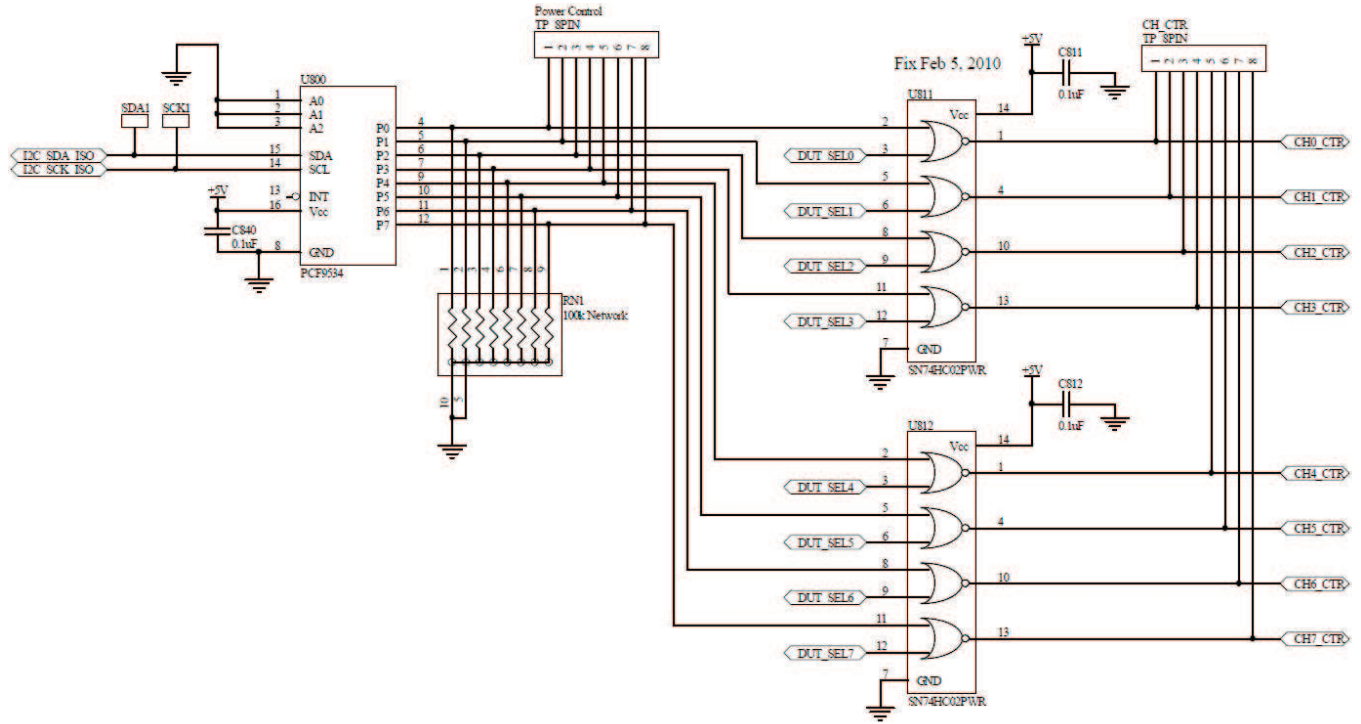

Figure 3. Power Control Logic Circuitry Schematic

Figure 4 shows the *One-to- $V_{OUT}$*  control section. This section is used for three-wire modules only. In three-wire modules, the power supply must be cycled immediately before communication can occur. In a three-wire module, U820 outputs a logic high on the channel that is being tested. The  $V_{DUT}$  signal from the USB DAQ Platform is gated through to control the power on the channel being tested.

The three-wire configuration is the only configuration that requires cycling power before communications. For other circuits, U820 outputs a logic low for all channels, and *DUT\_SEL* is low for all channels (disabled).

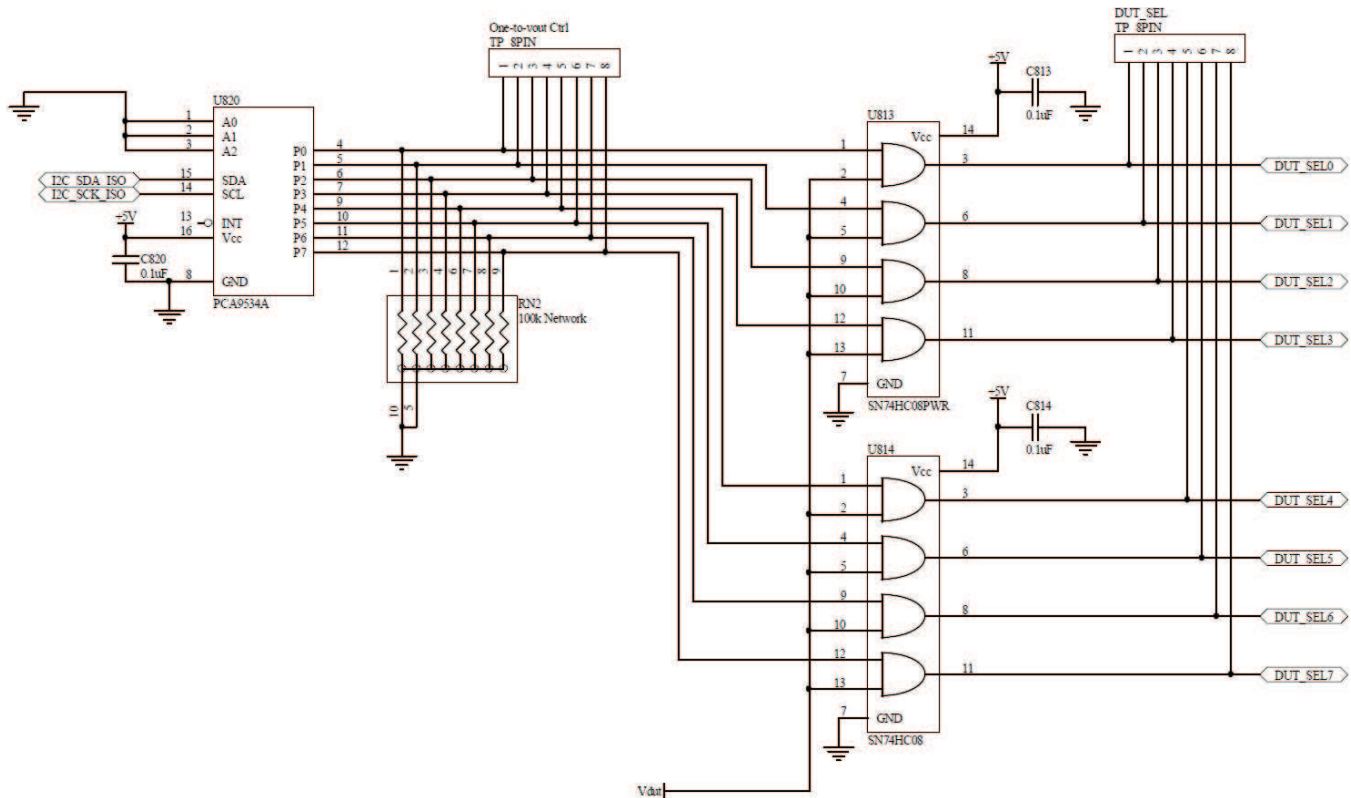

Figure 4. One-to- $V_{OUT}$  Circuitry Schematic

Figure 5 illustrates a simplified version (that is, a single channel) of the circuits shown in Figure 3 and Figure 4. The output (*CH\_CTR*) connects power to the sensor modules when it is low. Thus, if the power control is high, *CH\_CTR* is low and power is connected.

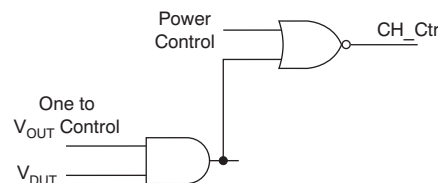

Figure 5. Simplified Gate Connection for Figure 3 and Figure 4

The AND gate is used for three-wire mode power control. In this case,  $V_{DUT}$  is used to turn the power on and off. When *Power Control* is set low and *One-to- $V_{OUT}$*  is set high, the  $V_{DUT}$  signal is gated to *CH\_CTR*.

The current meter control circuitry is shown in Figure 6. A logic low for IM\_CTR connects the current meter. The current meter is only connected to one channel at a time, so one of the eight channels will be driven low.

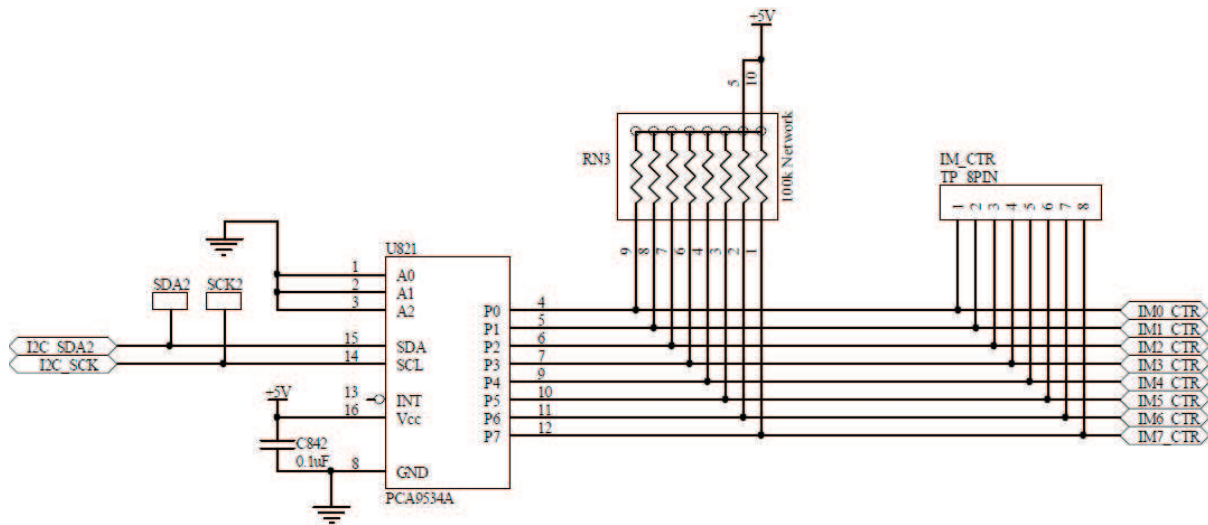

Figure 6. Current Meter Control Circuitry Schematic

Note that the current meter is only used for current output modules. Therefore, for other configurations, all of the outputs of U821 (IM\_CTR) are set high.

Figure 7 shows one of the eight power relay circuits. This circuit connects and disconnects power to the sensor modules. The circuit uses photo MOS relays because of the voltage and current ratings ( $V_{MAX} = 60V$ ,  $I_{MAX} = 600mA$ ). Photo MOS relays are intentionally selected rather than mechanical relays because they are not affected by mechanical issues.

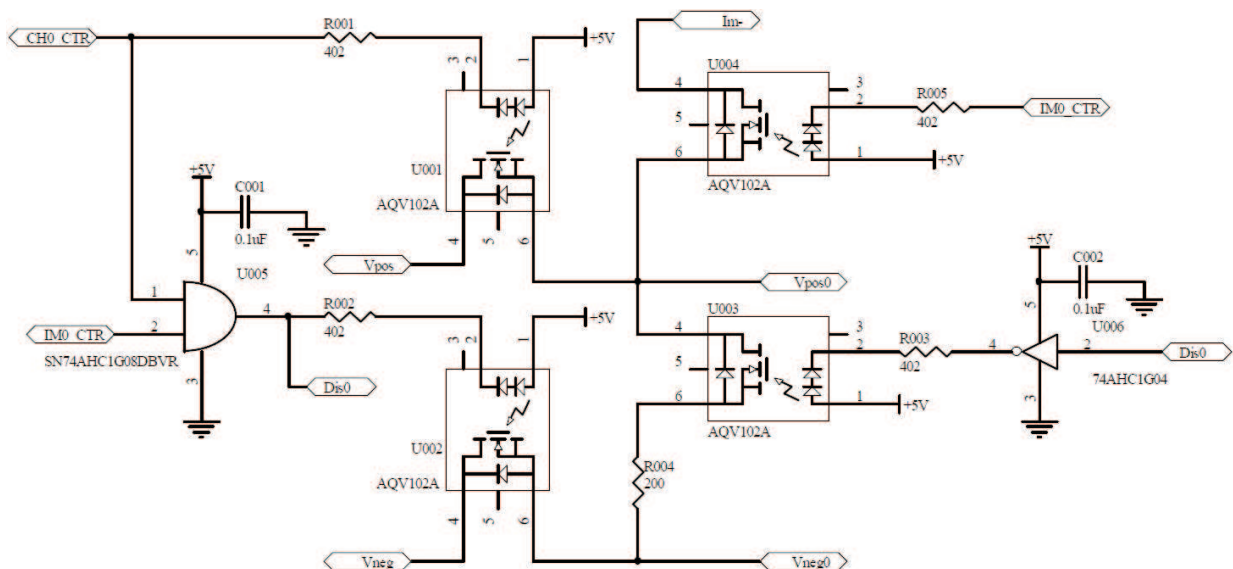

Figure 7. Power Relay Control Circuitry Schematic

As shown here, U001 and U002 are the main path for the positive and negative supply. When U001 and U002 are closed, power is delivered to the sensor module. When U001 and U002 are disconnected, U003 is used to discharge any capacitance on the power lines. U004 connects the ammeter to the path for current measurements. When the current measurement is being performed, U004 is on and U001 is off.

Table 1 summarizes the three modes of operation for the power control circuitry (as discussed in Figure 3 to Figure 7). Note that the current mode has three different states: current power on, current transition to measurement, and current measurement. In the current power on state all the good devices are powered. In the transition state the current meter is in parallel with the normal power supply path. In the current measurement state the normal power supply path is disconnected and the ammeter is connected for the channel that is being measured.

**Table 1. Power Control Circuitry Operating Modes**

| Mode                       | Power Control<br>(and $I_M$ Control)                            | One-to- $V_{DUT}$ Control                            | DUT Sel   | CH_CTR<br>(and $I_M$ Control)  |
|----------------------------|---|--|---|--|
| Three-wire                 | DUT = L<br>Good Units = H<br>Bad Units = L<br>$I_M$ Control = H | DUT=H<br>All Others = L                              | Will be controlled by the $V_{DUT}$ signal for the DUT. For all other devices, this is low. | Good units = L<br>Bad Units = H<br>DUT = NOT $V_{DUT}$   |
| Four-wire                  | Good Units = H<br>Bad Units = L<br>$I_M$ Control = H            | All Units = L<br>$V_{DUT}$ is ignored for this mode. | All units = L.<br>DUT Sel is not used in this mode.   | Good Units = L<br>Bad Units = H<br>Note the relay is turned on by a low. Good units that are turned on continuously. $V_{DUT}$ is ignored for this test.   |
| Current Power On           | Good Units = H<br>Bad Units = L<br>$I_M$ Control = H            | All Units = L<br>$V_{DUT}$ is ignored for this mode. | All units = L.<br>DUT Sel is not used in this mode.   | Good Units = L<br>Bad Units = H<br>Note the relay is turned on by a low. Good units that are turned on continuously. $V_{DUT}$ is ignored for this test. No current flows through $I_M$ at this step.  |
| Current Transition to Meas | Good Units = H<br>Bad Units = L<br>DUT = H<br>$I_M$ Control = L | All Units = L<br>$V_{DUT}$ is ignored for this mode. | All units = L.<br>DUT Sel is not used in this mode.   | Good Units = L<br>Bad Units = H<br>Note the relay is turned on by a low. Good units that are turned on continuously. $V_{DUT}$ is ignored for this test. At this step current flows through both $I_M$ and the normal power path (that is, U001 and U004). |
| Current Meas               | Good Units = H<br>Bad Units = L<br>DUT = L<br>$I_M$ Control = L | All Units = L<br>$V_{DUT}$ is ignored for this mode. | All units = L.<br>DUT Sel is not used in this mode.   | Good Units = L<br>Bad Units = H<br>Note the relay is turned on by a low. Good units that are turned on continuously. $V_{DUT}$ is ignored for this test. At this step current flows through both $I_M$ only (that is, U004).                               |



The circuit shown in Figure 8 latches the control signals from the USB DAQ Platform for use on the Multi-Cal-Master. The BCT signals enable or disable different devices on the board as well as select the specific channel. Note that the same control signals are present on any slave boards used. The signal on the clock pin (EN\_MAST) differentiates the master from the different slaves.

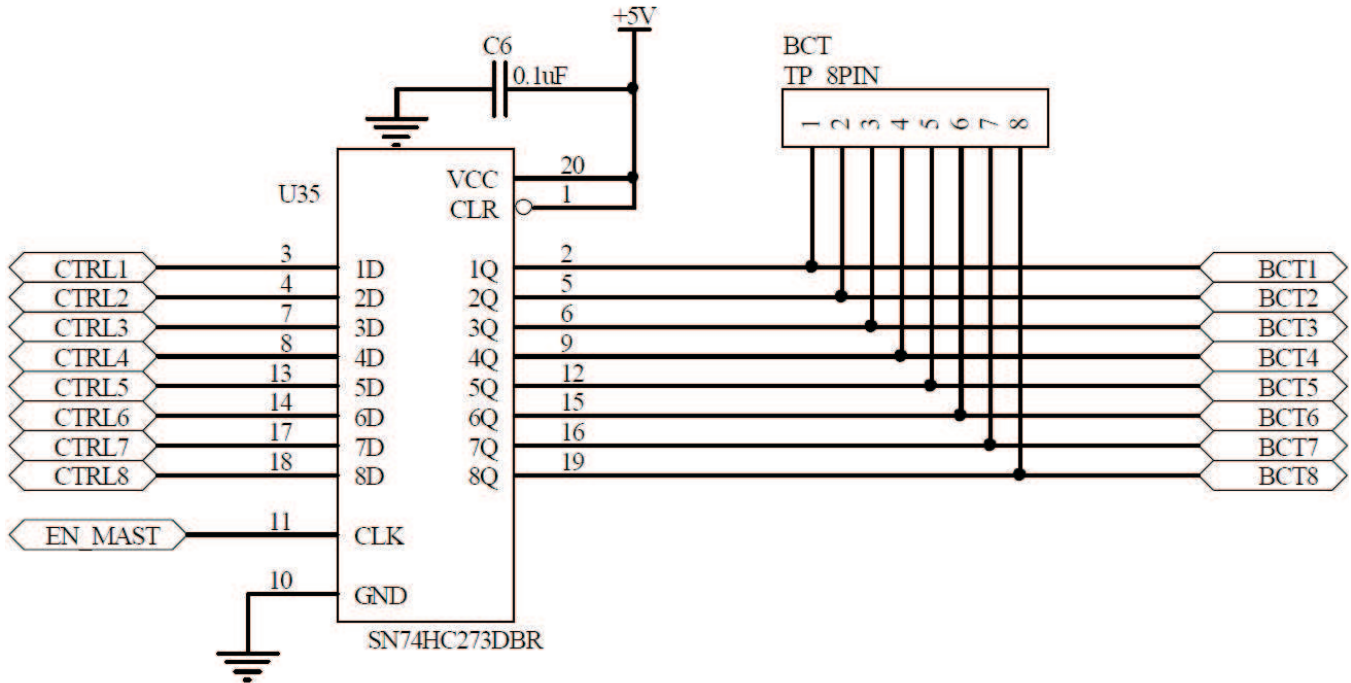

Figure 8. Control Signal Latch Circuitry Schematic

Figure 9 shows the SPI multiplexers. These components were developed for communications with the XTR108. They are not used on the PGA309 or PGA308. Note that these devices are selected with BCT5. BCT1 to BCT3 are used to select the channel.

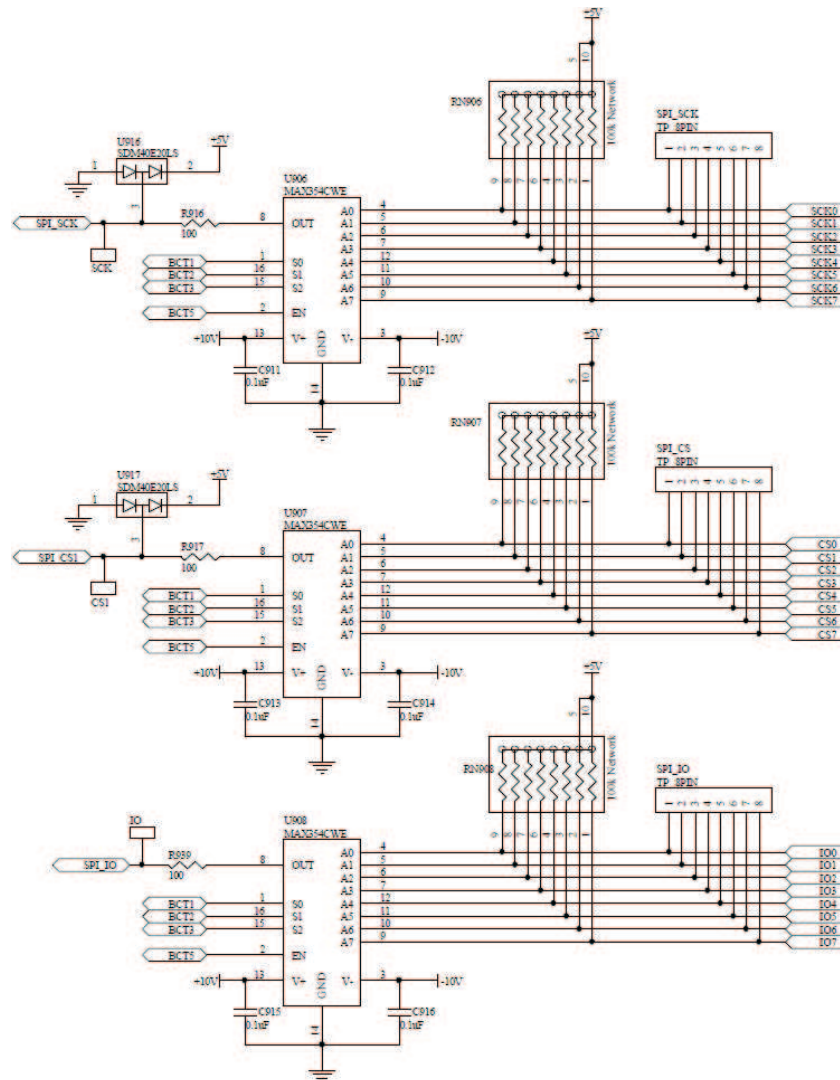

Figure 9. SPI Multiplexer Circuitry Schematic

Figure 10 illustrates the ONE\_WIRE signal that is multiplexed to the eight sensor modules. Note that these devices are selected with BCT7. BCT1 to BCT3 are used to select the channel.

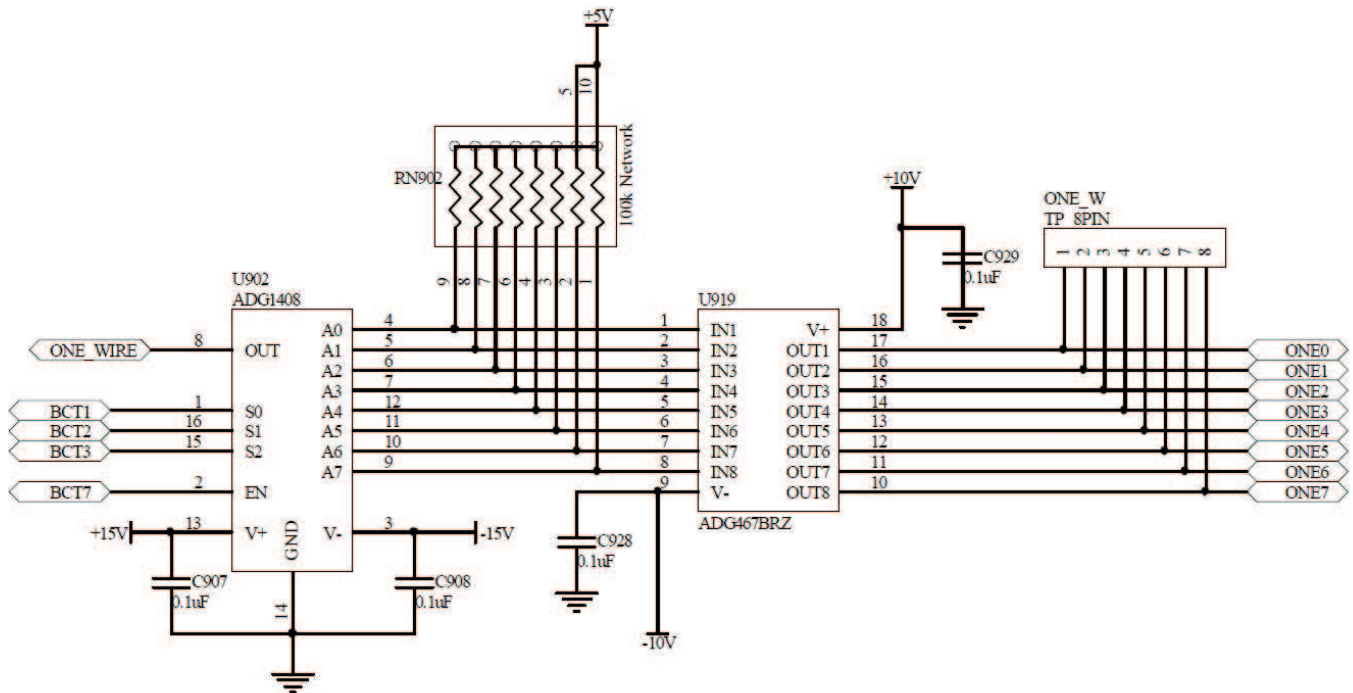

Figure 10. One-Wire Signal Multiplexed to Eight Sensor Modules

U919 is a channel protector device. This unit protects the Multi-Cal-Master from damage caused by wiring errors. For example, if the One-Wire pin on the sensor module is erroneously shorted to the power supply, the channel protector prevents damage on the Multi-Cal-Master.

Figure 11 shows the multiplexer for the voltmeter. U903 connects the sensor modules  $V_{OUT}$  signal to the voltmeter positive terminal. U904 connects a ground sense to the sensor module to the voltmeter negative terminal. U903 and U904 are only used on voltage out modules.

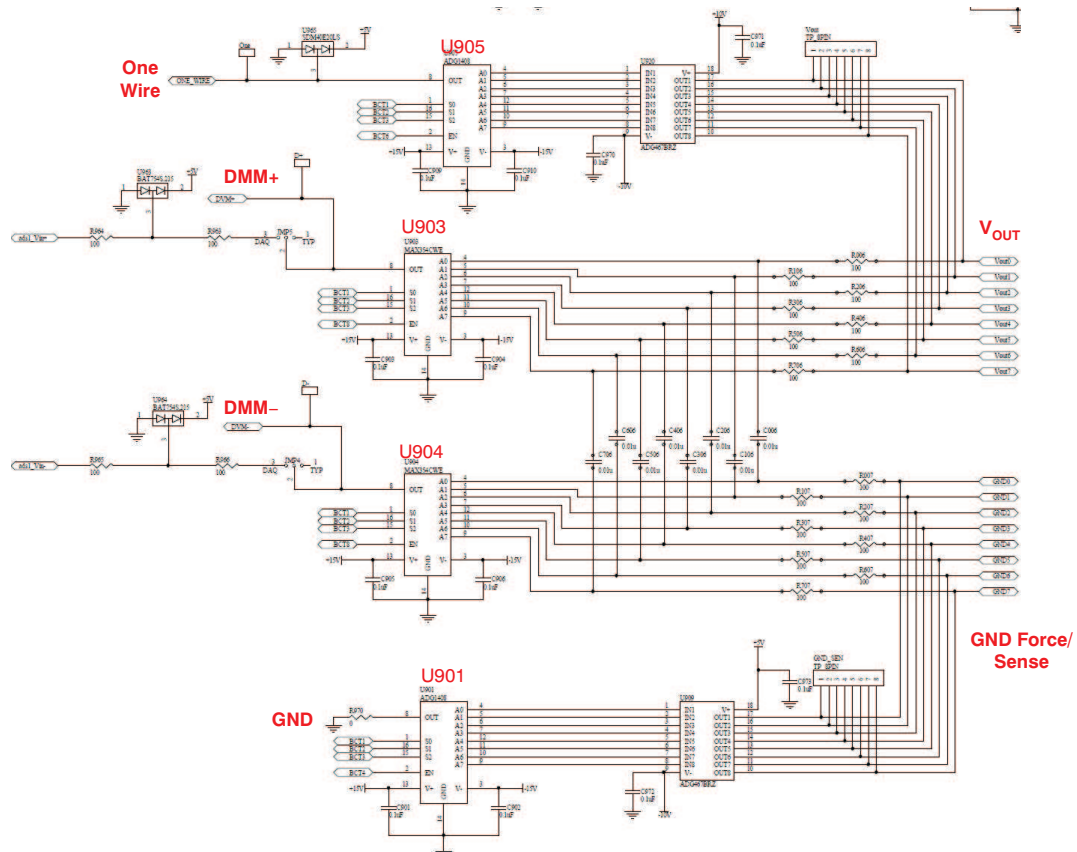

Figure 11. Multiplexer for Voltmeter

LEDs are used to indicate which channel is actively being calibrated. Figure 12 shows how the LED selection is performed by a 3-to-8 decoder. Note that the decoder is selected with BCT5. BCT1 to BCT3 are used to select the channel. Table 2 lists the functions of all the BCT control lines.

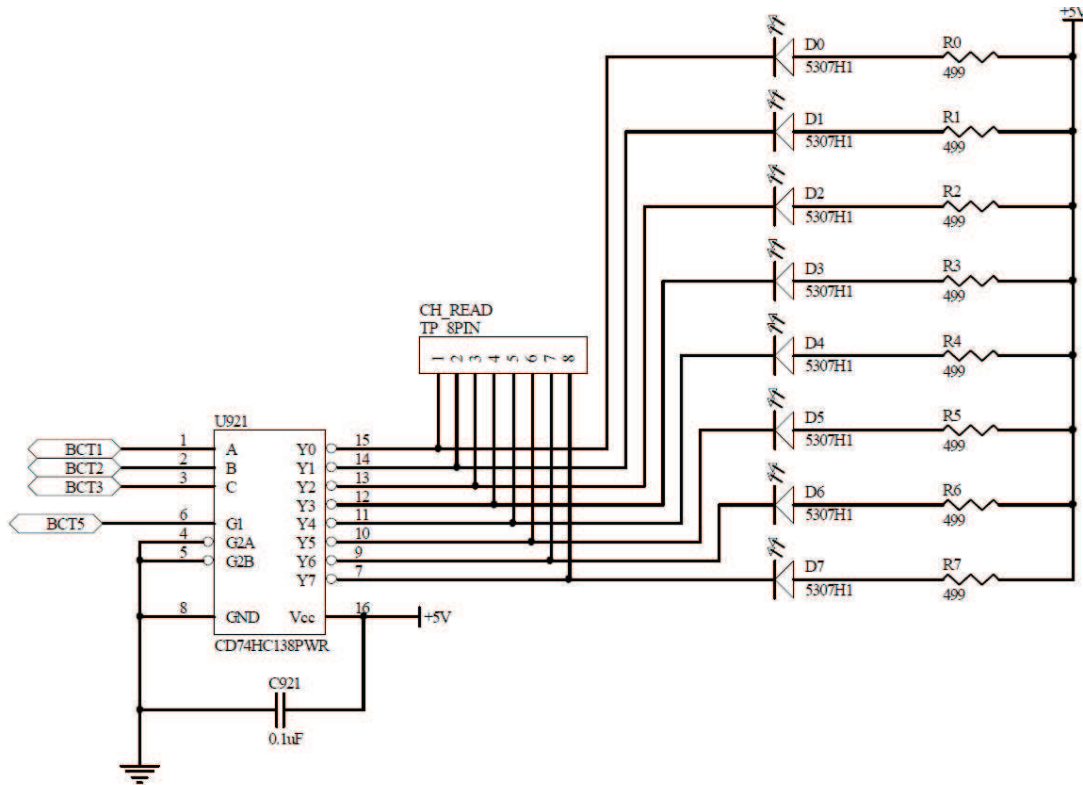
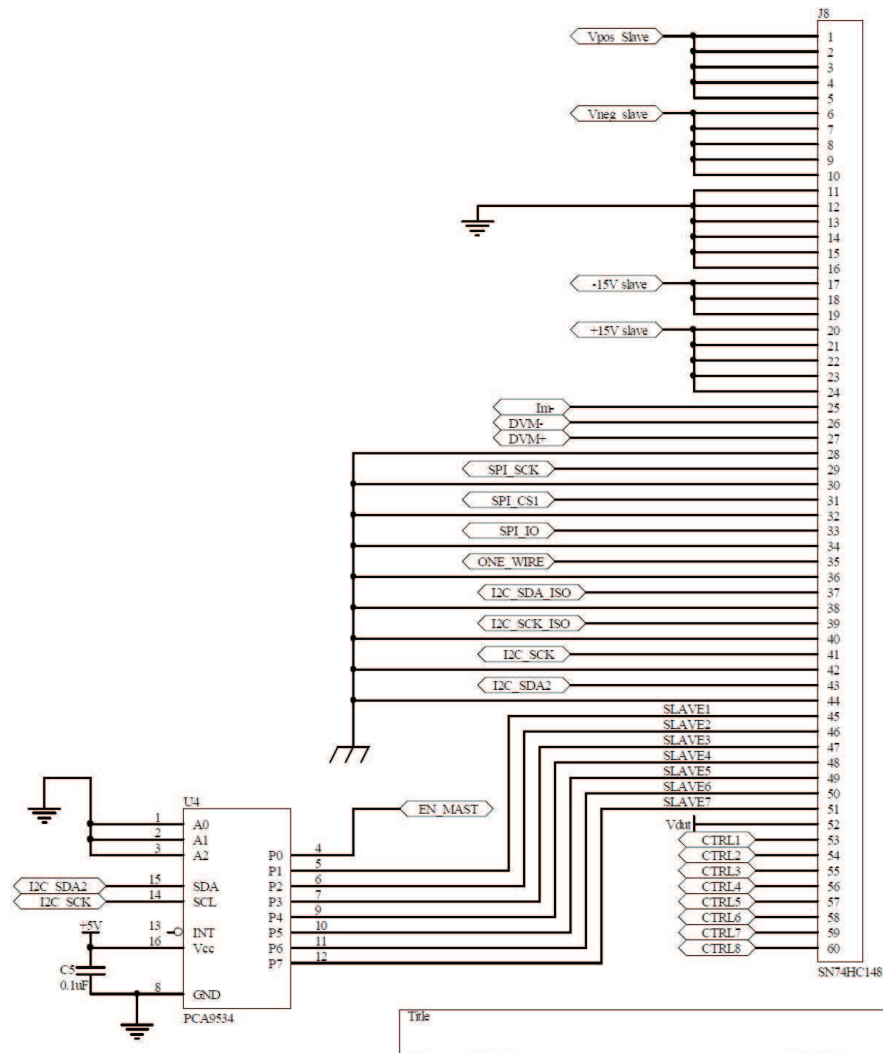

Figure 12. LED Selection Performed by Decoder

Table 2. BCT Control Line Functions

| BCT Line         | Devices   | Function  |
|------------------|---|---|
| BCT1, BCT2, BCT3 | U901, U902, U903, U904, U905, U906, U907, U908, | Selects the channel (one of eight).                                       |
| BCT4             | U901  | Ground force on current loop communication.                               |
| BCT5             | U906, U907, U908, U921                          | SPI communication for XTR108 calibration. Also enable for LED indicators. |
| BCT6             | U905  | One wire to $V_{OUT}$ for three wire modules.                             |
| BCT7             | U902  | One wire for four-wire modules and current out modules.                   |
| BCT8             | U903, U904                                      | Voltage multiplexer for voltage output modules.                           |

The ribbon cable connection to the slave is shown in Figure 13. U4 is used to select the slave or master to configure. U4 generates a clock signal on a latch on the slave and each master (see U35 on figure 13). The latch output are the control signals that configure the multiplexers on the board. Table 3 lists the pins and functions of the slave ribbon cable (J8).



**Figure 13. Ribbon Cable Connection to Multi-Cal-Slave**

**Table 3. Slave Ribbon Cable Pins and Functions**

| Pin                    | Signal           | Function   |
|------------------------|------------------|--|
| 1, 2, 3, 4, 5          | $V_{POS\_SLAVE}$ | This is a direct connection to the external supply for the sensor modules. The supply voltage is connected to each slave for distribution. Each slave has its own separate over current limit (poly fuse). |
| 6, 7, 8, 9, 10         | $V_{NEG\_SLAVE}$ | This is a direct connection to the external supply for the sensor modules. The supply voltage is connected to each slave for distribution. Each slave has its own separate over current limit (poly fuse). |
| 11, 12, 14, 14, 15, 16 | GND              | Multiple ground paths to support large currents.   |
| 17, 18, 19             | -15V slave       | Multiple -15V paths to support large current.  |

**Table 3. Slave Ribbon Cable Pins and Functions (continued)**

| Pin                            | Signal  | Function   |
|--------------------------------|---|--|
| 20, 21, 22, 23, 24             | +15V slave  | Multiple +15V paths to support large current. Note that +15V draws significantly more current than -15V  |
| 25                             | $I_M^-$   | Current meter connects directly to this pin.   |
| 26                             | DMM-  | Positive volt meter connects directly to this pin.   |
| 27                             | DMM+  | Negative volt meter connects directly to this pin.   |
| 28                             | Chassis GND   | Chassis ground is placed between communications lines to minimize capacitive coupling.   |
| 29                             | SPI_SCK   | Communication for XTR108: SPI clock  |
| 30                             | Chassis GND   |  |
| 31                             | SPI_CS1   | Communication for XTR108: SPI chip select  |
| 32                             | Chassis GND   |  |
| 33                             | SPI_IO  | Communication for XTR108: SPI input / output   |
| 34                             | Chassis GND   |  |
| 35                             | One Wire  | UART communication used on PGA309 and PGA308   |
| 36                             | Chassis GND   |  |
| 37                             | I2C_ISO_SDA   | I2C SDA (channel 1): sets up port expanders on the slave   |
| 38                             | Chassis GND   |  |
| 39                             | I2C_ISO_SCK   | I2C SCL (channel 1): sets up port expanders on the slave   |
| 40                             | Chassis GND   |  |
| 41                             | I2C_SCK   | I2C SCL (channel 2): sets up port expanders on the slave   |
| 42                             | Chassis GND   |  |
| 43                             | I2C_SDA2  | I2C SDA (channel 2): sets up port expanders on the slave   |
| 44                             | Chassis GND   |  |
| 45, 46, 47, 48, 49, 50, 51     | SLAVE1 to   |  |
| SLAVE7                         | SLAVE1 to SLAVE7 are used to clock data into the latch on the selected slave. |  |
| 52                             | $V_{DUT}$   | This signal from the USB DAQ is used in power supply control for three-wire voltage modules.   |
| 53, 54, 55, 56, 57, 58, 59, 60 | CTRL1 to CTRL8  | CTRL1 to CTRL8 are connected to a latch in each slave. The control signals are stored in the latch. The latch output controls the multiplexers on the board. |

Figure 14 shows all the regulators on the Multi-Cal-Master. The +10V and -10V supplies are used for the supply on the channel protector devices. The channel protectors are more effective at protection with lower supplies. The 8V supply can be used to power the USB DAQ Platform rather than the universal power source. The 5V supply provides power for all the logic and photo MOS relays. The photo MOS relays draw a significant amount of power; consequently, the 5V regulator package was selected to accommodate this power requirement.

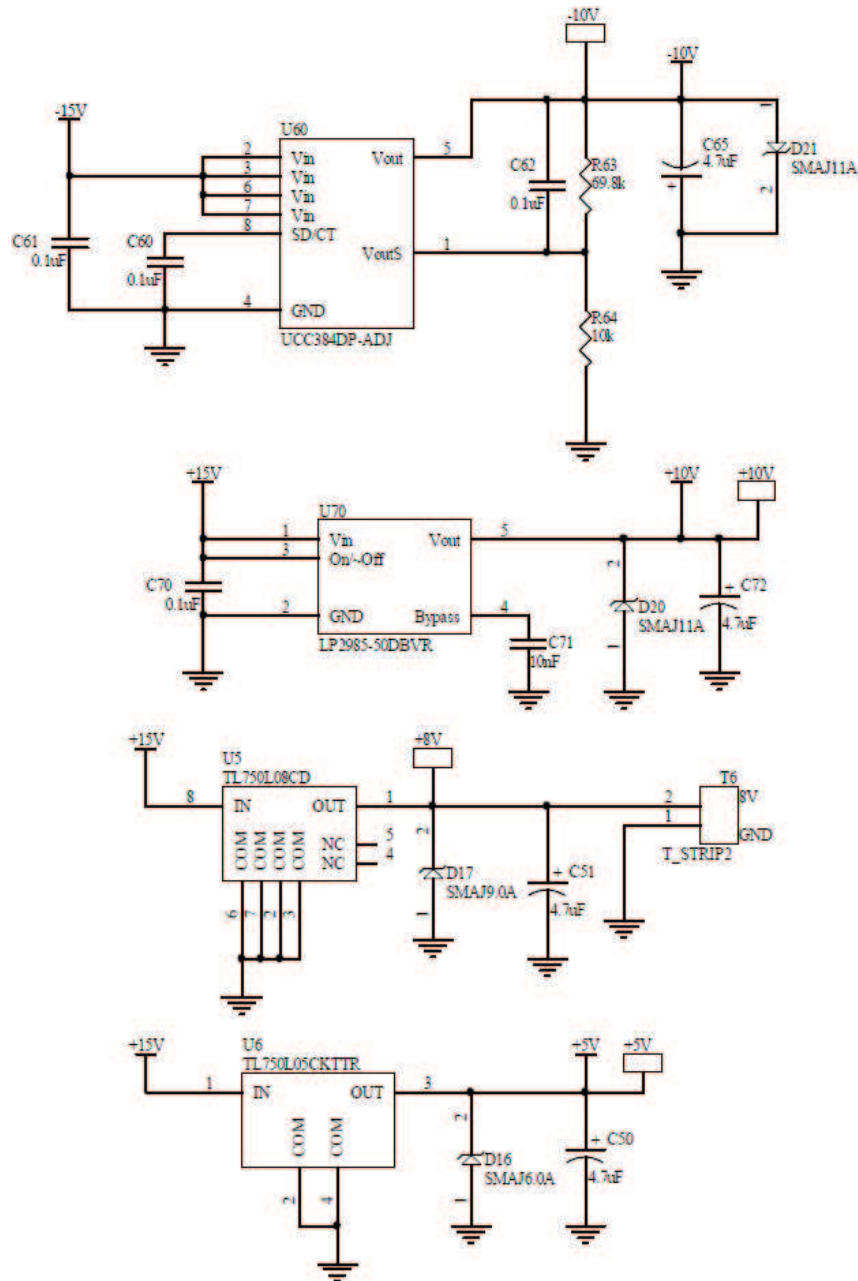

Figure 14. Multi-Cal-Master Regulators



The connection to the USB DAQ Platform is shown in Figure 15. Note that some of the signals are not used.

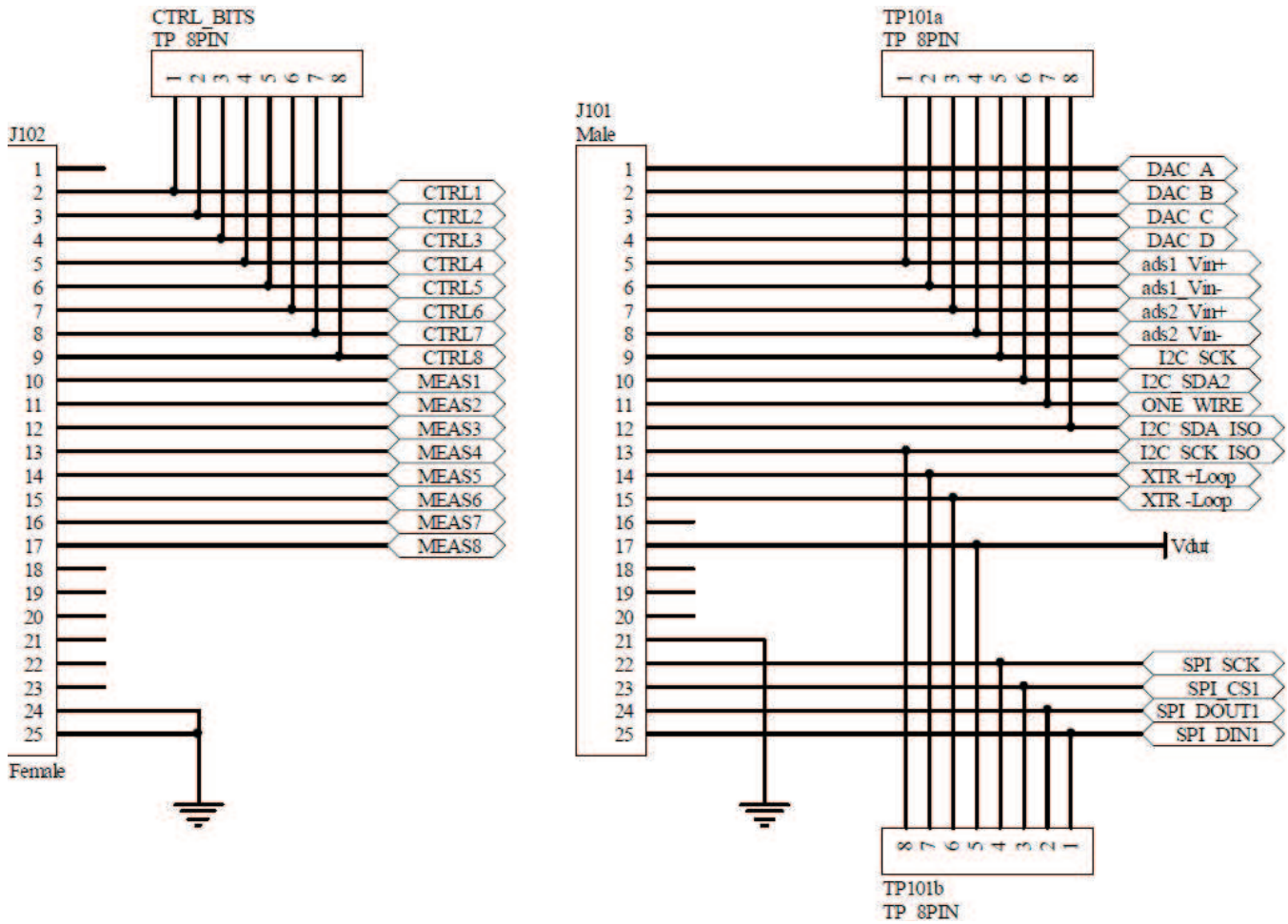

Figure 15. USB DAQ Platform Connection to Multi-Cal-Master

Table 4 and Table 5 summarize the signals that are used in J102 and J101, respectively.

Table 4. Signal Definitions for J102 from the USB DAQ Platform

| Pin      | Signal         | Function  |
|----------|----------------|---|
| 2 to 9   | CTRL1 to CTRL8 | Controls the multiplexers on the master and all slaves. |
| 10 to 17 | MEAS1 to MEAS8 | Not used  |
| 24, 25   | GND            | System GND  |

**Table 5. Signal Definition for J101 from the USB DAQ Platform**

| Pin    | Signal                     | Function  |
|--------|----------------------------|---|
| 1 to 4 | DAC_A, DAC_B, DAC_C, DAC_D | Not used  |
| 5, 6   | ads1_Vin+, ads1_Vin-       | Not used  |
| 7, 8   | Ads2_Vin+, ads2_Vin-       | Not used  |
| 9, 10  | I2C_SCK, I2C_SDA2          | Used for I <sup>2</sup> C bus expanders                 |
| 11     | ONE_WIRE                   | Used for communication to PGA309/PGA308                 |
| 12, 13 | I2C_SCK, I2C_SDA2          | Used for I <sup>2</sup> C bus expanders                 |
| 14, 15 | XTR+Loop, XTR-Loop         | Not used  |
| 17     | Vdut                       | Used to control power sequencing for three-wire modules |
| 21     | GND                        | System GND  |
| 22     | SPI_SCK                    |   |
| 23     | SPI_SCK                    |   |
| 24     | SPI_SCK                    |   |
| 25     | SPI_SCK                    |   |

Figure 16 shows the power and DMM connector for the Multi-Cal-Master. The signals connected to J9 are passed to the slave board via the ribbon cable J8.

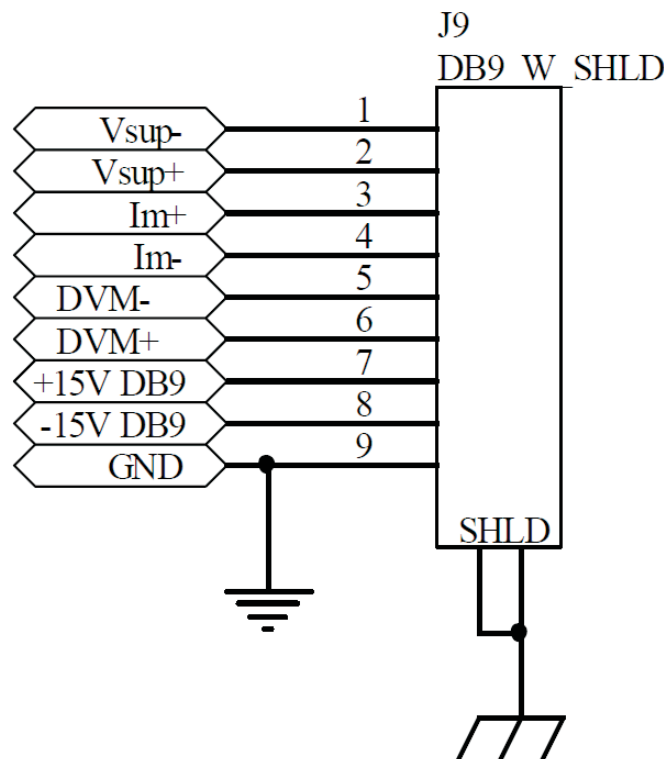
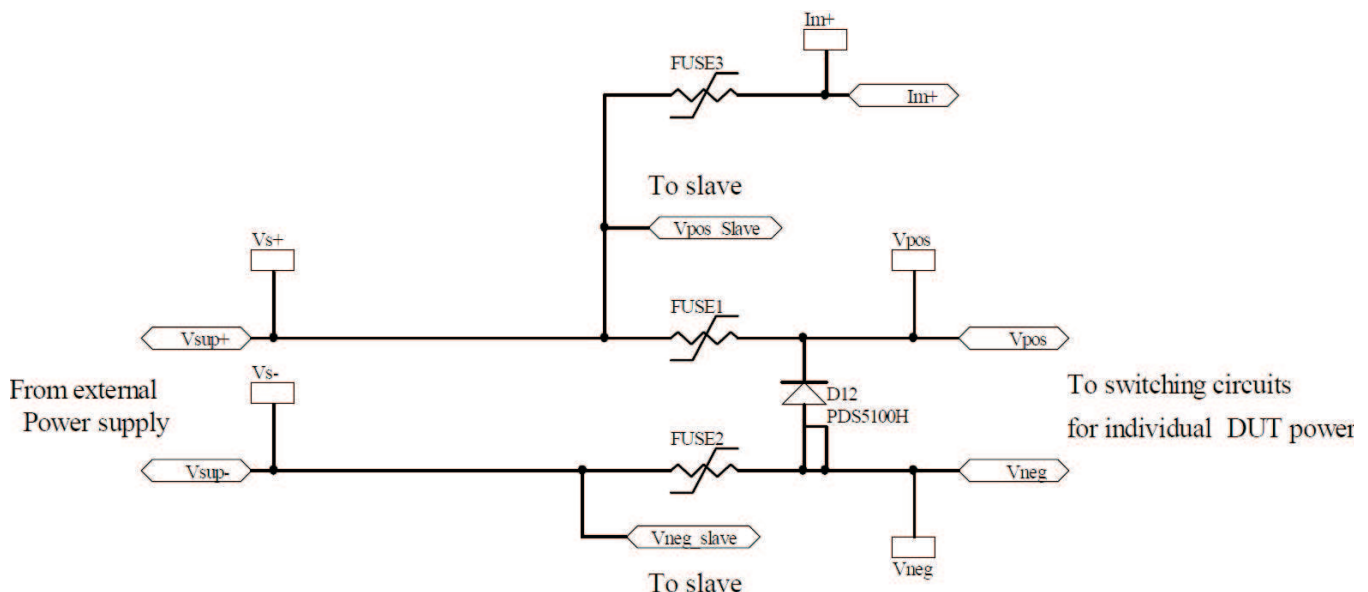

**Figure 16. Power and DMM Connector Circuitry Schematic**

Table 6 summarizes the connections to the power and DMM connector, J9.

**Table 6. J9 Power and Digital Multimeter Connections**

| Pin | Signal     | Function  |
|-----|------------|---|
| 1   | $V_{SUP-}$ | The negative device power supply. For voltage output modules this will be tied to ground. For current output modules this will float. |
| 2   | $V_{SUP+}$ | The positive device power supply. Max supply is 60V. This voltage is switched internally via AQV102A.                                 |
| 3   | $I_{M+}$   | This is connected to the positive ammeter connection for current loop calibration. This is not used for voltage calibration.          |
| 4   | $I_{M-}$   | This is connected to the negative ammeter connection for current loop calibration. This is not used for voltage calibration.          |
| 5   | DMM-       | This is connected to the negative volt meter connection for current loop calibration. This is not used for current loop calibration.  |
| 6   | DMM+       | This is connected to the positive volt meter connection for current loop calibration. This is not used for current loop calibration.  |
| 7   | +15V DB9   | This supply provides power for all the components on the Multi-Cal-Master and Multi-Cal-Slave boards.                                 |
| 8   | -15V DB9   | This supply provides power for all the components on the Multi-Cal-Master and Multi-Cal-Slave boards.                                 |
| 9   | GND        | Ground for the $\pm 15V$ supplies. System ground.   |

Figure 17 illustrates the device power-supply overcurrent protection for the Multi-Cal-Master. Fuse1 and Fuse2 are polyswitch 0.35A resetting fuses. These fuses protect the system if a sensor module is shorted. The total current requirement for the system can be significant (for example, 20mA x 64 sensors = 1.28A). The total current for each board is less than the system current (that is, 20mA x 8 sensors = 0.16A). The fuse circuit is repeated on each board so that we can set the overcurrent trip point to be relatively low (the board current is 0.16A and the trip point is 0.35A).



**Figure 17. Power-Supply Overcurrent Protection Circuitry Schematic**

Figure 18 illustrates the  $\pm 15\text{V}$  connection to the system. The  $\pm 15\text{V}$  supply can be connected at two different locations (T1 or J9). The  $\pm 15\text{V}$  supply should not be connected to both T1 and J9 simultaneously; however, the diodes protect the system from damage if both connections are made. The diodes also prevent reverse polarity connection damage.

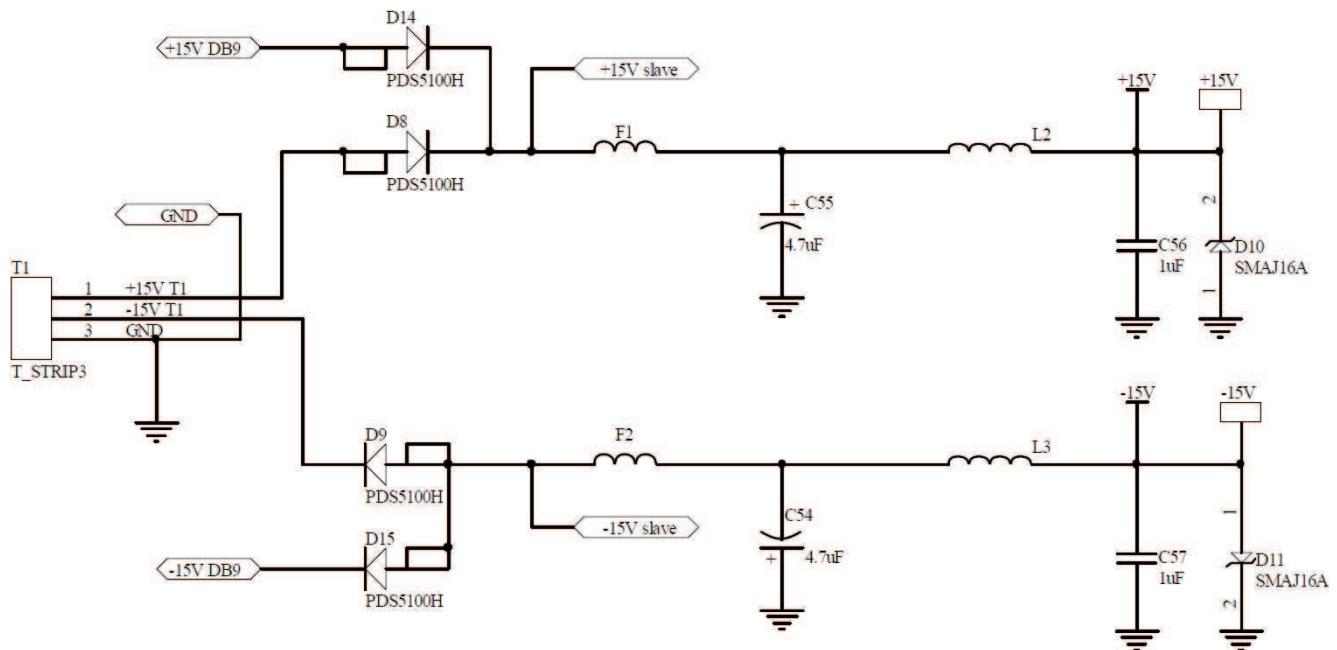

**Figure 18.  $\pm 15\text{V}$  System Connection**

The capacitors, inductors, and ferrite beads are used for power-supply noise rejection. Note that these circuits are repeated on each Multi-Cal-Slave board included in the system, so that the full system current does not flow through the coils and ferrite beads. The maximum system current for the  $+15\text{V}$  supply could be 1.6A, but the maximum current in a single master or slave is 0.2A. The current limit on the ferrite beads and coils is set according to the board requirements, not the system requirements.

Figure 19 shows the connectors that connect to the sensor modules. Each connector connects to four modules. Some of the signals on this connector are used for the XTR108 calibration and some are used for the PGA309/PGA308.

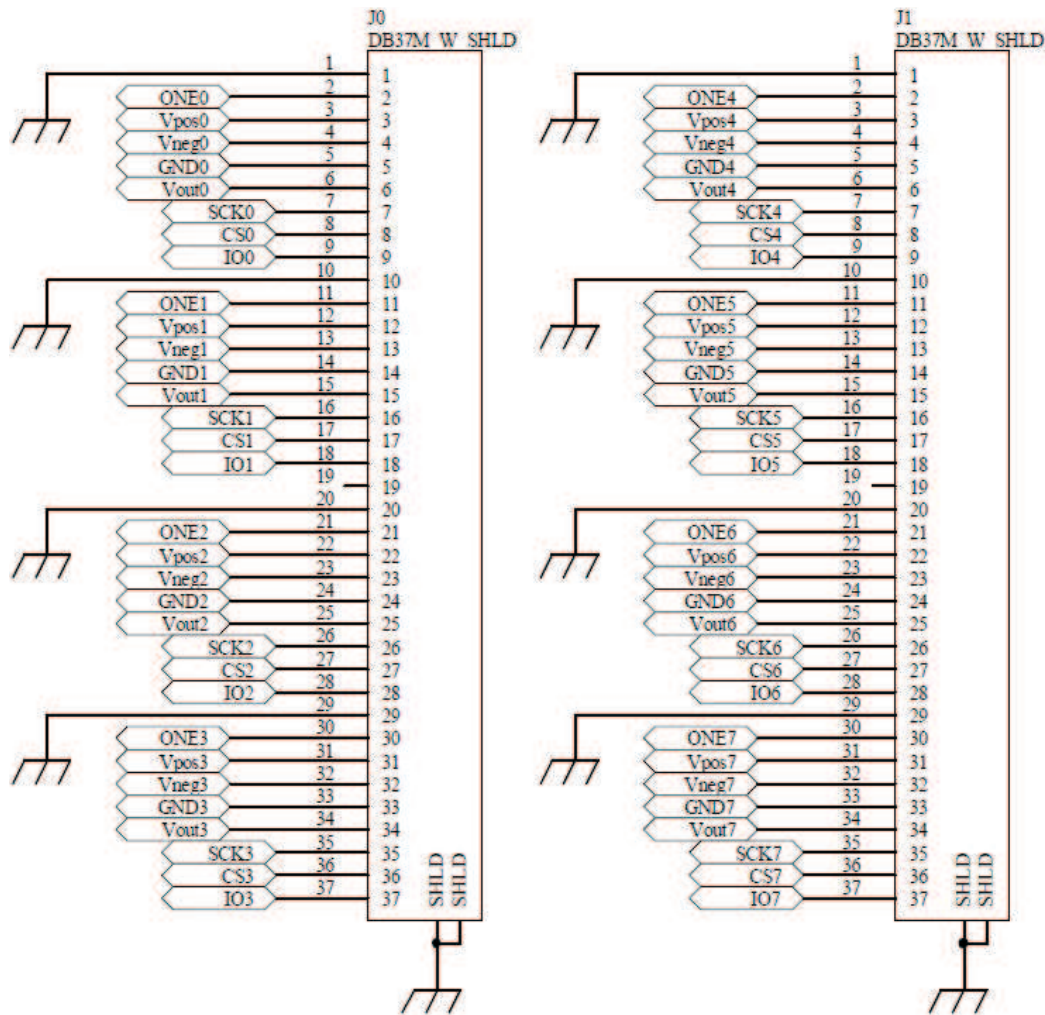

Figure 19. Sensor Module Connection Circuitry Schematic

Table 7 and Table 8 summarize the signals on J0 and J1, respectively.

**Table 7. J0: Signal Connection Summary**

| Pin J0 | Signal             | Function on J0  |
|--------|--------------------|---|
| 1      | Chassis ground     | Chassis ground  |
| 2      | One0               | One wire digital communication line.                                |
| 3      | Pos0               | Positive device supply.   |
| 4      | Neg0               | Negative device supply.   |
| 5      | GND0               | Ground force for current modules. Ground sense for voltage modules. |
| 6      | V <sub>OUT</sub> 0 | Output voltage measurement.   |
| 7      | SCK0               | SPI SCK for XTR108.   |
| 8      | CS0                | SPI CS0 for XTR108  |
| 9      | IO0                | SPI Input / Output for XTR108                                       |
| 10     | Chassis ground     | Pins 10 to 18 repeat the function of pins 1 to 9 for channel 2      |
| 11     | One1               |   |
| 12     | Pos1               |   |
| 13     | Neg1               |   |
| 14     | GND1               |   |
| 15     | V <sub>OUT</sub> 1 |   |
| 16     | SCK1               |   |
| 17     | CS1                |   |
| 18     | IO1                |   |
| 19     | —                  | No connection   |
| 20     | Chassis ground     | Pins 20 to 28 repeat the function of pins 1 to 9 for channel 3      |
| 21     | One2               |   |
| 22     | Pos2               |   |
| 23     | Neg2               |   |
| 24     | GND2               |   |
| 25     | V <sub>OUT</sub> 2 |   |
| 26     | SCK2               |   |
| 27     | CS2                |   |
| 28     | IO2                |   |
| 29     | Chassis ground     | Pins 29 to 37 repeat the function of pins 1 to 9 for channel 4      |
| 30     | One3               |   |
| 31     | Pos3               |   |
| 32     | Neg3               |   |
| 33     | GND3               |   |
| 34     | V <sub>OUT</sub> 3 |   |
| 35     | SCK3               |   |
| 36     | CS3                |   |
| 37     | IO3                |   |

**Table 8. J1: Signal Connection Summary**

| Pin J1 | Signal             | Function on J1  |
|--------|--------------------|---|
| 1      | Chassis ground     | Chassis ground  |
| 2      | One4               | One wire digital communication line.                                |
| 3      | Pos4               | Positive device supply.   |
| 4      | Neg4               | Negative device supply.   |
| 5      | GND4               | Ground force for current modules. Ground sense for voltage modules. |
| 6      | V <sub>OUT</sub> 4 | Output voltage measurement.   |
| 7      | SCK4               | SPI SCK for XTR108.   |
| 8      | CS4                | SPI CS0 for XTR108  |
| 9      | IO4                | SPI Input / Output for XTR108                                       |
| 10     | Chassis ground     | Pins 10 to 18 repeat the function of pins 1 to 9 for channel 2      |
| 11     | One5               |   |
| 12     | Pos5               |   |
| 13     | Neg5               |   |
| 14     | GND5               |   |
| 15     | V <sub>OUT</sub> 5 |   |
| 16     | SCK5               |   |
| 17     | CS5                |   |
| 18     | IO5                |   |
| 19     | —                  | No connection   |
| 20     | Chassis ground     | Pins 20 to 28 repeat the function of pins 1 to 9 for channel 3      |
| 21     | One6               |   |
| 22     | Pos6               |   |
| 23     | Neg6               |   |
| 24     | GND6               |   |
| 25     | V <sub>OUT</sub> 6 |   |
| 26     | SCK6               |   |
| 27     | CS6                |   |
| 28     | IO6                |   |
| 29     | Chassis ground     | Pins 29 to 37 repeat the function of pins 1 to 9 for channel 4      |
| 30     | One7               |   |
| 31     | Pos7               |   |
| 32     | Neg7               |   |
| 33     | GND7               |   |
| 34     | V <sub>OUT</sub> 7 |   |
| 35     | SCK7               |   |
| 36     | CS7                |   |
| 37     | IO7                |   |

### 3 Bill of Materials

Table 9 shows the parts list for the Multi-Cal-Master EVM.

**Table 9. Multi-Cal-Master EVM Parts List**

| Qty | Ref Des   | Description                                 | Vendor                           | Part Number          |
|-----|---|---|----------------------------------|----------------------|
| 9   | C006, C106,<br>C206, C306,<br>C406, C506,<br>C606, C706,<br>C71   | Capacitor, 10000pF 50V ceramic X7R 0603     | Kemet                            | C0603C103K5RACTU     |
| 53  | C6, C5, C60,<br>C61, C62, C840,<br>C842, C907,<br>C908, C909,<br>C910, C901,<br>C902, C903,<br>C904, C905,<br>C906, C911,<br>C912, C913,<br>C914, C915,<br>C916, C921,<br>C928, C929,<br>C938, C970,<br>C971, C972,<br>C973, C001,<br>C002, C101,<br>C102, C201,<br>C202, C301,<br>C302, C401,<br>C402, C501,<br>C502, C601,<br>C602, C701,<br>C702, C811,<br>C812, C813,<br>C814, C820,<br>C70 | Capacitor, .10μF 25V ceramic Y5V 0603       | Kemet                            | C0603C104M3VACTU     |
| 2   | C56, C57  | Capacitor, ceramic 1μF 25V X5R 0603         | Murata Electronics North America | GRM188R61E105KA12D   |
| 6   | C54, C55, C50,<br>C51, C65, C72   | Capacitor, tantalum 4.7μF 35V 20% SMD       | Nichicon                         | F931V475MCC          |
| 4   | C1, C2, C3, C4  | Capacitor, ceramic .01μF 10% 1000V X7R 1206 | Vishay/Vitramon                  | VJ1206Y103KXGAT5Z    |
| 1   | R938  | Resistor, 49.9 kΩ 1/10W 1% 0603 SMD         | Panasonic - ECG                  | ERJ-3EKF4992V        |
| 1   | R8  | Resistor, 1MΩ 1% 1206 TF high voltage       | Stackpole Electronics Inc        | HVCB 1206 T2 1M 1% I |
| 8   | R0, R1, R2, R3,<br>R4, R5, R6, R7   | Resistor, 499Ω 1/10W 1% 603 SMD             | Panasonic - ECG                  | ERJ-3EKF4990V        |
| 23  | R006, R106,<br>R206, R306,<br>R406, R506,<br>R606, R706,<br>R007, R107,<br>R207, R307,<br>R407, R507,<br>R607,<br>R707, R939,<br>R917, R916,<br>R963, R964,<br>R965, R966   | Resistor, 100Ω 1/10W 5% 0603 SMD            | Stackpole Electronics Inc        | RMCF 1/16 100 5% R   |
| 8   | R004, R104,<br>R204, R304,<br>R404, R504,<br>R604, R704,  | Resistor, 200Ω 1/4W 5% 1206 SMD             | Stackpole Electronics Inc        | RMCF 1/8 200 5% R    |



**Table 9. Multi-Cal-Master EVM Parts List (continued)**

| Qty | Ref Des   | Description                                  | Vendor                    | Part Number        |
|-----|---|--|---------------------------|--------------------|
| 32  | R001, R002, R003, R005, R101, R102, R103, R105, R201, R202, R203, R205, R301, R302, R303, R305, R401, R402, R403, R405, R501, R502, R503, R505, R601, R602, R603, R605, R701, R702, R703, R705  | Resistor, 402Ω 1/10W 1% 0603 SMD             | Panasonic - ECG           | ERJ-3EKF4020V      |
| 1   | R64   | Resistor, 10kΩ 1/10W 1% 0603 SMD             | Stackpole Electronics Inc | RMCF 1/16 10K 1% R |
| 1   | R63   | Resistor, 69.8kΩ 1/10W 1% 0603 SMD           | Yageo                     | RC0603FR-0769K8L   |
| 7   | RN1, RN2, RN3, RN902, RN906, RN907, RN908   | Resistor, array 100kΩ 10 TRM BSS SMD         | CTS Resistor Products     | 746X101104JP       |
| 1   | R970  | Resistor, 0.0Ω 1/4W 5% 1206 SMD              | Vishay/Dale               | CRCW12060000Z0EA   |
| 3   | U901, U902, U905  | IC, SW mux analog 1/8CH 16-TSSOP             | Analog Devices Inc        | ADG1408YRUZ        |
| 5   | U903, U904, U906, U907, U908  | IC, Multiplexer 8x1 16-SOIC                  | Maxim                     | MAX354CWE          |
| 3   | U919, U920, U909  | IC, Channel protector OCTAL 18-SOIC          | Analog Devices Inc        | ADG467BRZ          |
| 32  | U001, U002, U003, U004, U101, U102, U103, U104, U201, U202, U203, U204, U301, U302, U303, U304, U401, U402, U403, U404, U501, U502, U503, U504, U601, U602, U603, U604, U701, U702, U703, U704, | Relay opto dc 60V 600MA 6-SMD                | Panasonic Electric Works  | AQV102A            |
| 6   | U963, U964, U965, U916, U917, U939  | Diode, schottky 30V 200mA SOT23-3            | NXP Semiconductors        | BAT754S,215        |
| 2   | U800, U4  | IC, I/O Expander I <sup>2</sup> C 8B 16-SOIC | Texas Instruments         | PCA9534DWR         |
| 2   | U820, U821  | IC, I/O Expander I <sup>2</sup> C 8B 16-SOIC | Texas Instruments         | PCA9534ADWR        |
| 1   | U938  | IC, Buff/DVR non-invert SOT23-5              | Texas Instruments         | SN74LVC1G07DBVR    |
| 1   | U70   | IC, LDO Reg 10V 150mA SOT23-5                | Texas Instruments         | LP2985A-10DBVR     |
| 1   | U921  | IC, 3-to-8 decoder/demux 16-SSOP             | Texas Instruments         | SN74HC138DBR       |
| 1   | U60   | IC, .5A Neg adj lin LDO Reg 8-SOIC           | Texas Instruments         | UCC384DP-ADJ       |
| 1   | U6  | IC, LDO Reg 150mA 5V D2PAK-3 TO-263          | Texas Instruments         | TL750L05CKTTR      |
| 1   | U5  | IC, 8V 150mA LDO Reg 8-SOIC                  | Texas Instruments         | TL750L08CD         |
| 8   | U005, U105, U205, U305, U405, U505, U605, U705  | IC, Single 2in pos-AND gate SOT23-5          | Texas Instruments         | SN74AHC1G08DBVR    |

**Table 9. Multi-Cal-Master EVM Parts List (continued)**

| Qty | Ref Des  | Description  | Vendor                           | Part Number      |
|-----|--|--|----------------------------------|------------------|
| 8   | U006, U106,<br>U206, U306,<br>U406, U506,<br>U606, U706                                      | IC, Single inverter gate SOT23-5   | Texas Instruments                | SN74AHC1G04DBVR  |
| 2   | U811, U812   | IC, Quad 2-Input NOR gate 14-SOIC  | Texas Instruments                | SN74HC02D        |
| 2   | U813, U814   | IC, Quad 2-Input AND I 14-SOIC   | Texas Instruments                | SN74HC08D        |
| 1   | U35  | IC, Oct D-type f-f w/Clr 20-SSOP   | Texas Instruments                | SN74HC273DBR     |
| 8   | U005, U105,<br>U205, U305,<br>U405, U505,<br>U605, U705                                      | IC, Single 2-in pos-AND gate SOT23-5   | Texas Instruments                | SN74AHC1G08DBVR  |
| 8   | U006, U106,<br>U206, U306,<br>U406, U506,<br>U606, U706                                      | IC, Single inverter gate SOT23-5   | Texas Instruments                | SN74AHC1G04DBVR  |
| 2   | U811, U812   | IC, Quad 2-Input NOR gate 14-SOIC  | Texas Instruments                | SN74HC02D        |
| 2   | U813, U814   | IC, Quad 2-Input AND gate 14-SOIC  | Texas Instruments                | SN74HC08D        |
| 1   | U35  | IC, Oct D-type F-F W/CLR 20-SSOP   | Texas Instruments                | SN74HC273DBR     |
| 8   | D0, D1, D2, D3,<br>D4, D5, D6, D7  | LED, red T1-3/4 right angle PCB  | CML Innovative Technologies      | 5307H1           |
| 2   | D10, D11   | Diode TVS 16V 400W unidirectional 5% SMA                                       | Littelfuse Inc                   | SMAJ16A          |
| 2   | D20, D21   | TVS 400W 11V unidirectional SMA  | Littelfuse Inc                   | SMAJ11A-TP       |
| 1   | D17  | Diode TVS 9.0V 400W unidirectional 5% SMA                                      | Littelfuse Inc                   | SMAJ9.0A         |
| 1   | D16  | Diode TVS 6.0V 400W unidirectional 5% SMA                                      | Littelfuse Inc                   | SMAJ6.0A         |
| 5   | D12, D8, D9,<br>D14, D15   | Diode Schottky 100V 5A powerDI5  | Diodes Inc                       | PDS5100H-13      |
| 3   | Fuse1, Fuse2,<br>Fuse3   | Polyswitch .35A reset fuse SMD   | Tyco Electronics                 | NANOSMDC035F-2   |
| 2   | L2, L3   | Inductor, unshielded 100µH .52A SMD  | JW Miller A Bourns Company       | PM54-101K-RC     |
| 2   | F1, F2   | Ferrite chip 120Ω 3000mA 1206  | Murata Electronics North America | BLM31PG121SN1    |
| 2   | J0, J1   | Connector, DB37 male .318" R/A nickel  | Norcomp Inc.                     | 182-037-113R531  |
| 1   | J9   | Connector, DSUB plug R/A 9pos gold/FL  | AMP/Tyco Electronics             | 1734352-1        |
| 1   | J102   | Connector, DSUB rcpt R/A 25pos 30 gold (with threaded inserts and board locks) | AMP/Tyco Electronics             | 5747846-4        |
| 1   | J101   | Connector, DSUB plug R/A 25pos 30 gold (with threaded inserts and board locks) | AMP/Tyco Electronics             | 5747842-4        |
| 1   | J8   | Connector, Header low-Pro 60-POS gold  | Assmann Electronics Inc          | AWHW60G-0202-T-R |
| 8   | CH_ON,<br>CH_OFF, MBIT,<br>SPI_SCK,<br>SPI_CS,<br>SPI_IO, ONE,<br>V <sub>OUT</sub> , GND_SEN | Connector  | Omit                             | Omit             |
| 4   | JMP1, JMP2,<br>JMP4, JMP4  | Header, 3-position 0.100" SGL Gold   | Samtec                           | TSW-103-07-G-S   |
| 4   | JMP1, JMP2,<br>JMP4, JMP5  | Shunt LP w/handle 2 POS 30AU   | Tyco Electronics                 | 881545-2         |
| 1   | T1   | Terminal block 5MM 3POS  | ON SHORE TECHNOLOGY              | ED300/3          |
| 1   | T6   | Terminal block 5MM 2POS  | ON SHORE TECHNOLOGY              | ED300/2          |

**Table 9. Multi-Cal-Master EVM Parts List (continued)**

| <b>Qty</b> | <b>Ref Des</b>                             | <b>Description</b>               | <b>Vendor</b>        | <b>Part Number</b> |
|------------|--|----------------------------------|----------------------|--------------------|
| 16         | M1-M8 and USB<br>DAQ Standoffs<br>(bottom) | Standoff hex M/F 4-40 1.125"ALUM | Keystone Electronics | 8406               |
| 16         | M1-M8 and USB<br>DAQ Standoffs<br>(top)    | Standoff hex 4-40THR ALUM .250"  | Keystone Electronics | 2201               |
| 6          | Use on J0, J1,<br>J9                       | Female screwlock 4-40 .312"      | Norcomp Inc.         | SFSO4401NR         |

## Evaluation Board/Kit Important Notice

Texas Instruments (TI) provides the enclosed product(s) under the following conditions:

This evaluation board/kit is intended for use for **ENGINEERING DEVELOPMENT, DEMONSTRATION, OR EVALUATION PURPOSES ONLY** and is not considered by TI to be a finished end-product fit for general consumer use. Persons handling the product(s) must have electronics training and observe good engineering practice standards. As such, the goods being provided are not intended to be complete in terms of required design-, marketing-, and/or manufacturing-related protective considerations, including product safety and environmental measures typically found in end products that incorporate such semiconductor components or circuit boards. This evaluation board/kit does not fall within the scope of the European Union directives regarding electromagnetic compatibility, restricted substances (RoHS), recycling (WEEE), FCC, CE or UL, and therefore may not meet the technical requirements of these directives or other related directives.

Should this evaluation board/kit not meet the specifications indicated in the User's Guide, the board/kit may be returned within 30 days from the date of delivery for a full refund. **THE FOREGOING WARRANTY IS THE EXCLUSIVE WARRANTY MADE BY SELLER TO BUYER AND IS IN LIEU OF ALL OTHER WARRANTIES, EXPRESSED, IMPLIED, OR STATUTORY, INCLUDING ANY WARRANTY OF MERCHANTABILITY OR FITNESS FOR ANY PARTICULAR PURPOSE.**

The user assumes all responsibility and liability for proper and safe handling of the goods. Further, the user indemnifies TI from all claims arising from the handling or use of the goods. Due to the open construction of the product, it is the user's responsibility to take any and all appropriate precautions with regard to electrostatic discharge.

**EXCEPT TO THE EXTENT OF THE INDEMNITY SET FORTH ABOVE, NEITHER PARTY SHALL BE LIABLE TO THE OTHER FOR ANY INDIRECT, SPECIAL, INCIDENTAL, OR CONSEQUENTIAL DAMAGES.**

TI currently deals with a variety of customers for products, and therefore our arrangement with the user **is not exclusive.**

TI assumes **no liability for applications assistance, customer product design, software performance, or infringement of patents or services described herein.**

Please read the User's Guide and, specifically, the Warnings and Restrictions notice in the User's Guide prior to handling the product. This notice contains important safety information about temperatures and voltages. For additional information on TI's environmental and/or safety programs, please contact the TI application engineer or visit [www.ti.com/esh](http://www.ti.com/esh).

No license is granted under any patent right or other intellectual property right of TI covering or relating to any machine, process, or combination in which such TI products or services might be or are used.

## FCC Warning

This evaluation board/kit is intended for use for **ENGINEERING DEVELOPMENT, DEMONSTRATION, OR EVALUATION PURPOSES ONLY** and is not considered by TI to be a finished end-product fit for general consumer use. It generates, uses, and can radiate radio frequency energy and has not been tested for compliance with the limits of computing devices pursuant to part 15 of FCC rules, which are designed to provide reasonable protection against radio frequency interference. Operation of this equipment in other environments may cause interference with radio communications, in which case the user at his own expense will be required to take whatever measures may be required to correct this interference.

## EVM Warnings and Restrictions

It is important to operate this EVM within the input voltage range of 5.7V to 9V and the output voltage range of 0V to 5V.

Exceeding the specified input range may cause unexpected operation and/or irreversible damage to the EVM. If there are questions concerning the input range, please contact a TI field representative prior to connecting the input power.

Applying loads outside of the specified output range may result in unintended operation and/or possible permanent damage to the EVM. Please consult the EVM User's Guide prior to connecting any load to the EVM output. If there is uncertainty as to the load specification, please contact a TI field representative.

During normal operation, some circuit components may have case temperatures greater than +25°C. The EVM is designed to operate properly with certain components above +25°C as long as the input and output ranges are maintained. These components include but are not limited to linear regulators, switching transistors, pass transistors, and current sense resistors. These types of devices can be identified using the EVM schematic located in the EVM User's Guide. When placing measurement probes near these devices during operation, please be aware that these devices may be very warm to the touch.

Mailing Address: Texas Instruments, Post Office Box 655303, Dallas, Texas 75265  
Copyright © 2010, Texas Instruments Incorporated

## IMPORTANT NOTICE

Texas Instruments Incorporated and its subsidiaries (TI) reserve the right to make corrections, modifications, enhancements, improvements, and other changes to its products and services at any time and to discontinue any product or service without notice. Customers should obtain the latest relevant information before placing orders and should verify that such information is current and complete. All products are sold subject to TI's terms and conditions of sale supplied at the time of order acknowledgment.

TI warrants performance of its hardware products to the specifications applicable at the time of sale in accordance with TI's standard warranty. Testing and other quality control techniques are used to the extent TI deems necessary to support this warranty. Except where mandated by government requirements, testing of all parameters of each product is not necessarily performed.

TI assumes no liability for applications assistance or customer product design. Customers are responsible for their products and applications using TI components. To minimize the risks associated with customer products and applications, customers should provide adequate design and operating safeguards.

TI does not warrant or represent that any license, either express or implied, is granted under any TI patent right, copyright, mask work right, or other TI intellectual property right relating to any combination, machine, or process in which TI products or services are used. Information published by TI regarding third-party products or services does not constitute a license from TI to use such products or services or a warranty or endorsement thereof. Use of such information may require a license from a third party under the patents or other intellectual property of the third party, or a license from TI under the patents or other intellectual property of TI.

Reproduction of TI information in TI data books or data sheets is permissible only if reproduction is without alteration and is accompanied by all associated warranties, conditions, limitations, and notices. Reproduction of this information with alteration is an unfair and deceptive business practice. TI is not responsible or liable for such altered documentation. Information of third parties may be subject to additional restrictions.

Resale of TI products or services with statements different from or beyond the parameters stated by TI for that product or service voids all express and any implied warranties for the associated TI product or service and is an unfair and deceptive business practice. TI is not responsible or liable for any such statements.

TI products are not authorized for use in safety-critical applications (such as life support) where a failure of the TI product would reasonably be expected to cause severe personal injury or death, unless officers of the parties have executed an agreement specifically governing such use. Buyers represent that they have all necessary expertise in the safety and regulatory ramifications of their applications, and acknowledge and agree that they are solely responsible for all legal, regulatory and safety-related requirements concerning their products and any use of TI products in such safety-critical applications, notwithstanding any applications-related information or support that may be provided by TI. Further, Buyers must fully indemnify TI and its representatives against any damages arising out of the use of TI products in such safety-critical applications.

TI products are neither designed nor intended for use in military/aerospace applications or environments unless the TI products are specifically designated by TI as military-grade or "enhanced plastic." Only products designated by TI as military-grade meet military specifications. Buyers acknowledge and agree that any such use of TI products which TI has not designated as military-grade is solely at the Buyer's risk, and that they are solely responsible for compliance with all legal and regulatory requirements in connection with such use.

TI products are neither designed nor intended for use in automotive applications or environments unless the specific TI products are designated by TI as compliant with ISO/TS 16949 requirements. Buyers acknowledge and agree that, if they use any non-designated products in automotive applications, TI will not be responsible for any failure to meet such requirements.

Following are URLs where you can obtain information on other Texas Instruments products and application solutions:

| <b>Products</b>             |  | <b>Applications</b>        |  |
|-----------------------------|--|----------------------------|--|
| Amplifiers                  | <a href="http://amplifier.ti.com">amplifier.ti.com</a>             | Audio                      | <a href="http://www.ti.com/audio">www.ti.com/audio</a>                                   |
| Data Converters             | <a href="http://dataconverter.ti.com">dataconverter.ti.com</a>     | Automotive                 | <a href="http://www.ti.com/automotive">www.ti.com/automotive</a>                         |
| DLP® Products               | <a href="http://www.dlp.com">www.dlp.com</a>                       | Communications and Telecom | <a href="http://www.ti.com/communications">www.ti.com/communications</a>                 |
| DSP                         | <a href="http://dsp.ti.com">dsp.ti.com</a>                         | Computers and Peripherals  | <a href="http://www.ti.com/computers">www.ti.com/computers</a>                           |
| Clocks and Timers           | <a href="http://www.ti.com/clocks">www.ti.com/clocks</a>           | Consumer Electronics       | <a href="http://www.ti.com/consumer-apps">www.ti.com/consumer-apps</a>                   |
| Interface                   | <a href="http://interface.ti.com">interface.ti.com</a>             | Energy                     | <a href="http://www.ti.com/energy">www.ti.com/energy</a>                                 |
| Logic                       | <a href="http://logic.ti.com">logic.ti.com</a>                     | Industrial                 | <a href="http://www.ti.com/industrial">www.ti.com/industrial</a>                         |
| Power Mgmt                  | <a href="http://power.ti.com">power.ti.com</a>                     | Medical                    | <a href="http://www.ti.com/medical">www.ti.com/medical</a>                               |
| Microcontrollers            | <a href="http://microcontroller.ti.com">microcontroller.ti.com</a> | Security                   | <a href="http://www.ti.com/security">www.ti.com/security</a>                             |
| RFID                        | <a href="http://www.ti-rfid.com">www.ti-rfid.com</a>               | Space, Avionics & Defense  | <a href="http://www.ti.com/space-avionics-defense">www.ti.com/space-avionics-defense</a> |
| RF/IF and ZigBee® Solutions | <a href="http://www.ti.com/lprf">www.ti.com/lprf</a>               | Video and Imaging          | <a href="http://www.ti.com/video">www.ti.com/video</a>                                   |
|                             |  | Wireless                   | <a href="http://www.ti.com/wireless-apps">www.ti.com/wireless-apps</a>                   |

Mailing Address: Texas Instruments, Post Office Box 655303, Dallas, Texas 75265  
Copyright © 2010, Texas Instruments Incorporated