

TPS65310A-Q1 Efficiency

Michael Wendt

ABSTRACT

The TPS65310A-Q1 device is a power management unit that meets the requirements of DSP-controlled automotive systems (Advanced Driver Assistance Systems). The device integrates commonly-used features, which reduces board space and system costs.

The device includes one high-voltage buck controller for pre-regulation, and two buck controllers and one boost converter for post-regulation. A further integrated low-dropout regulator (LDO) rounds up the power-supply concept and offers a flexible system design with five independent voltage rails. The device offers a low-power-state LPM0 with all rails turned off to reduce current consumption in case the system is constantly connected to the battery line. All outputs are protected against overload and over temperature. An external PMOS allows the device to sustain voltage transients up to 80 V as a protection feature. This external PMOS protects the system in safety-critical applications if a rail shows a malfunction (undervoltage, overvoltage, undercurrent, or overcurrent). Internal soft start ensures controlled startup for all supplies. Each power supply output has an adjustable output voltage based on the external resistor network settings. For more information, see the TPS65310A-Q1 data sheet, [SLVSC15](#).

The efficiency of the buck and boost regulators is important for the efficiency and thermal design of the system. This application report shows efficiency measurement results.

Contents

| | | |
|---|--|---|
| 1 | Efficiency Test of TPS65310A-Q1 | 2 |
| 2 | Efficiency Test Setup | 2 |
| | 2.1 Efficiency Test Setup of Buck1 | 2 |
| | 2.2 Efficiency Test Setup of Buck2 and Buck3 | 3 |
| | 2.3 Efficiency Test Setup of BOOST | 4 |
| 3 | Application Data | 4 |
| 4 | Test Results | 5 |
| | 4.1 Buck1 Efficiency | 5 |
| | 4.2 Buck2 Efficiency | 5 |
| | 4.3 Buck3 Efficiency | 6 |
| | 4.4 BOOST Efficiency | 6 |
| 5 | Efficiency Test Summary | 6 |

1 Efficiency Test of TPS65310A-Q1

The efficiency of a DC-DC converter is the output power divided by the input power and is typically represented as a percentage. The TPS65310A-Q1 device has a pre-buck regulator, Buck1. This external power supply (car battery) supplies the buck regulator. The output of the Buck1 regulator is the supply of the regulators Buck2, Buck3, BOOST, and LDO.

The standard method is used to measure the efficiency of the Buck1 regulator. This method calculates the efficiency by the standard way of measuring the input power and the output power. Because the Buck2, Buck3, BOOST, and LDO are supplied from Buck1, more effort is required to measure input power. Buck2, Buck3, BOOST, and LDO cannot be separated because the TPS65310A device is a safety device and monitors to correct the function of all regulators. If one regulator shows a failure, the device will try to start-up seven times, but because of failure, the device ends in LPM0 state. For more details, please see the [TPS65310A-Q1 data sheet](#).

2 Efficiency Test Setup

To perform the test, the device is placed on the TPS65310AEVM (see the EVM user's guide, [SLVU912](#)).

2.1 Efficiency Test Setup of Buck1

An external lab supply, V_{PROG} , supplies the board and device under test (DUT). The input current is measured with an ammeter I_{IN} . An additional voltmeter measures V_{IN} to ensure the correct input voltage measurement.

A source meter creates the load current I_{OUT} . Another voltmeter measures the output voltage V_{OUT} .

The efficiency of the input and output power was calculated using V_{IN} , I_{IN} , V_{OUT} , and I_{OUT} .

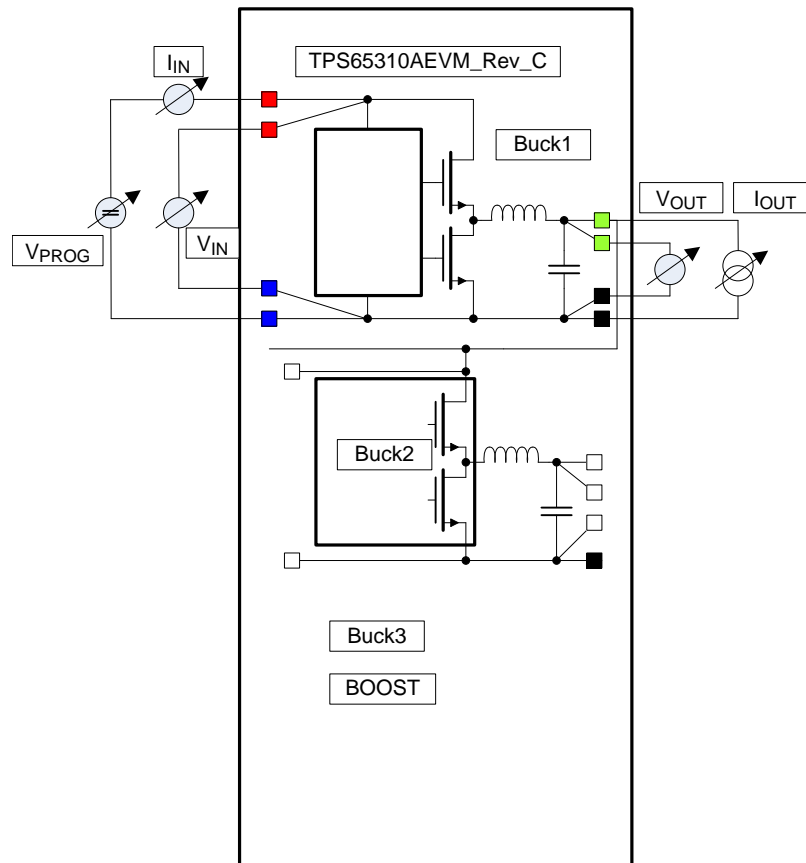

Figure 1. Efficiency Test Setup of Buck1

2.2 Efficiency Test Setup of Buck2 and Buck3

An external lab supply, V_{PROG} , supplies the board and DUT. The input currents of Buck2 and Buck3 were measured with a voltmeter across a shunt resistor and I_{IN} was calculated. An additional voltmeter measures V_{IN} to ensure the correct input voltage measurement (see Figure 2 and Figure 3).

A source meter created the load current I_{OUT} . Another voltmeter measured the output voltage V_{OUT} .

The efficiency of the input and output power was calculated using the V_{IN} , I_{IN} , V_{OUT} , and I_{OUT} .

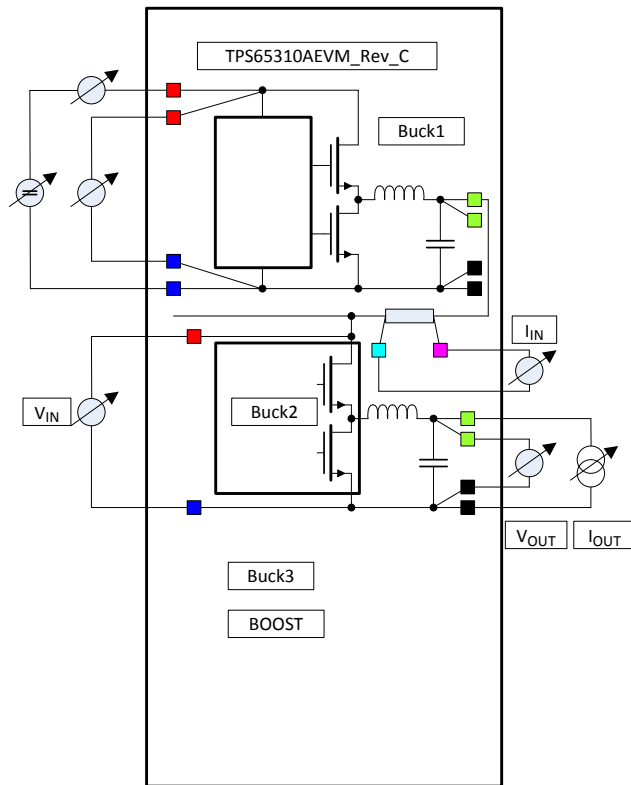

Figure 2. Efficiency Test Setup of Buck2

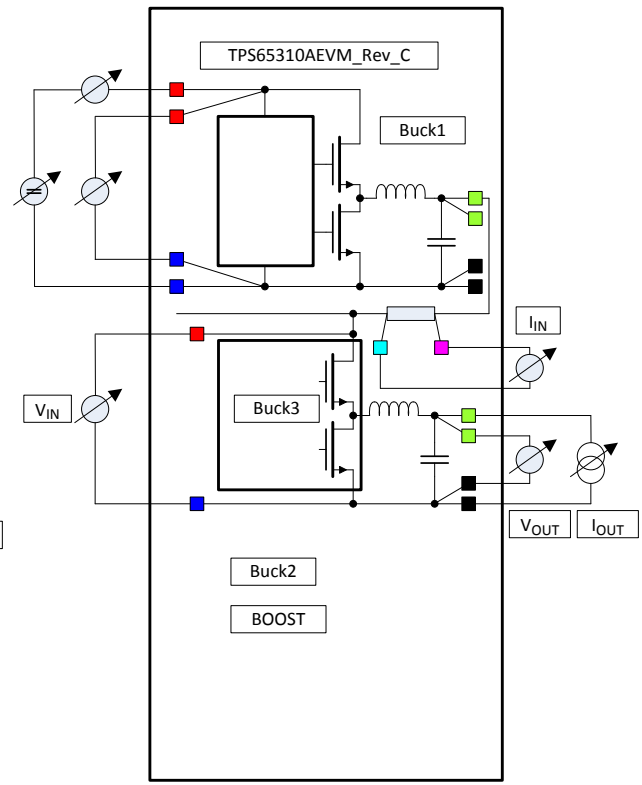

Figure 3. Efficiency Test Setup of Buck3

2.3 Efficiency Test Setup of BOOST

An external lab supply, V_{PROG} , supplies the board and DUT. The input current of BOOST was measured with a voltmeter across a shunt resistor and I_{IN} was calculated. An additional voltmeter measured V_{IN} to ensure the correct input voltage measurement (see Figure 4).

A source meter created the load current I_{OUT} . Another voltmeter measured the output voltage V_{OUT} .

The efficiency of the input and output power was calculated using the V_{IN} , I_{IN} , V_{OUT} , and I_{OUT} .

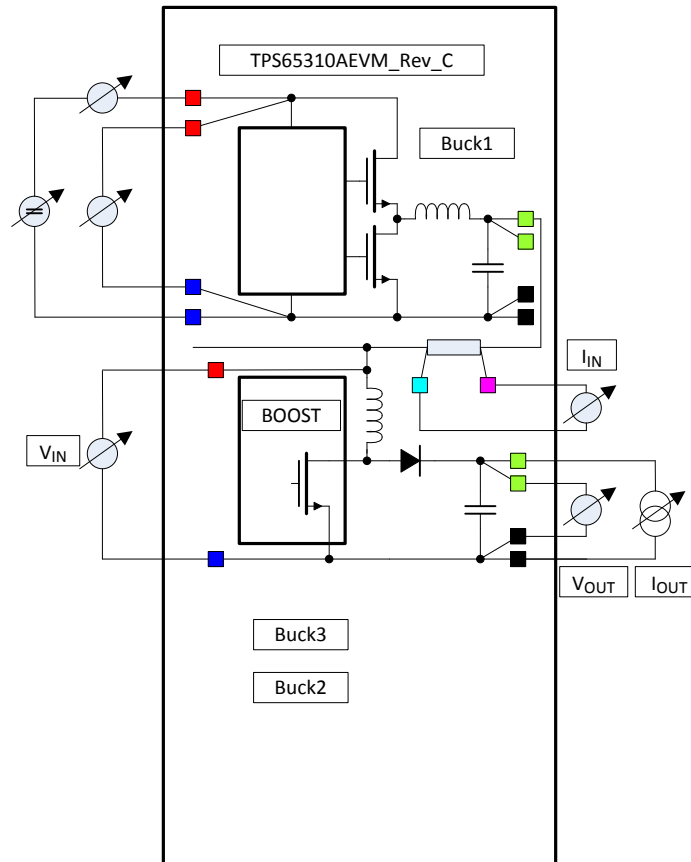

Figure 4. Efficiency Test Setup of BOOST

3 Application Data

| Board | | Used board: TPS65310AEVM_Rev_C |
|--------|------------|--|
| Buck 1 | VBAT | 5 V, 8.1 V, 10 V, 14 V, 18 V, 22 V, 26 V, 30 V, 34 V, 36 V, 37 V |
| | V_{OUT} | 3.8 V |
| | I_{Load} | 0 to 2.5 A |
| Buck 2 | VBAT | 13.8 V |
| | V_{OUT} | 3.3 V |
| | I_{Load} | 0 to 2.4 A |
| Buck 3 | VBAT | 13.8 V |
| | V_{OUT} | 1.2 V |
| | I_{Load} | 0 to 2.4 A |
| BOOST | VBAT | 13.8 V |
| | V_{OUT} | 5 V |
| | I_{Load} | 0 to 0.3 A |

4 Test Results

4.1 Buck1 Efficiency

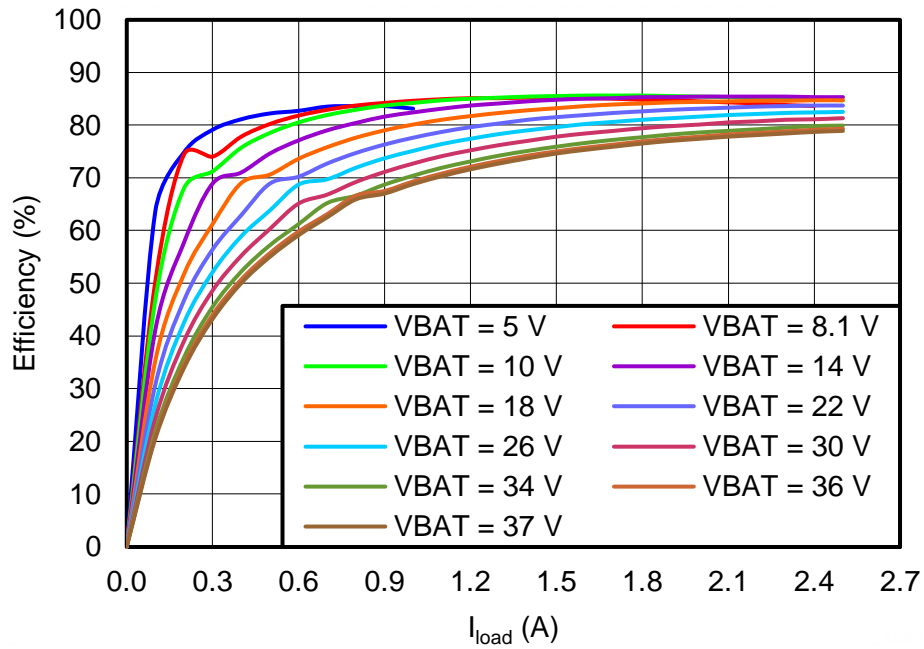

Figure 5. Efficiency Results of Buck1

4.2 Buck2 Efficiency

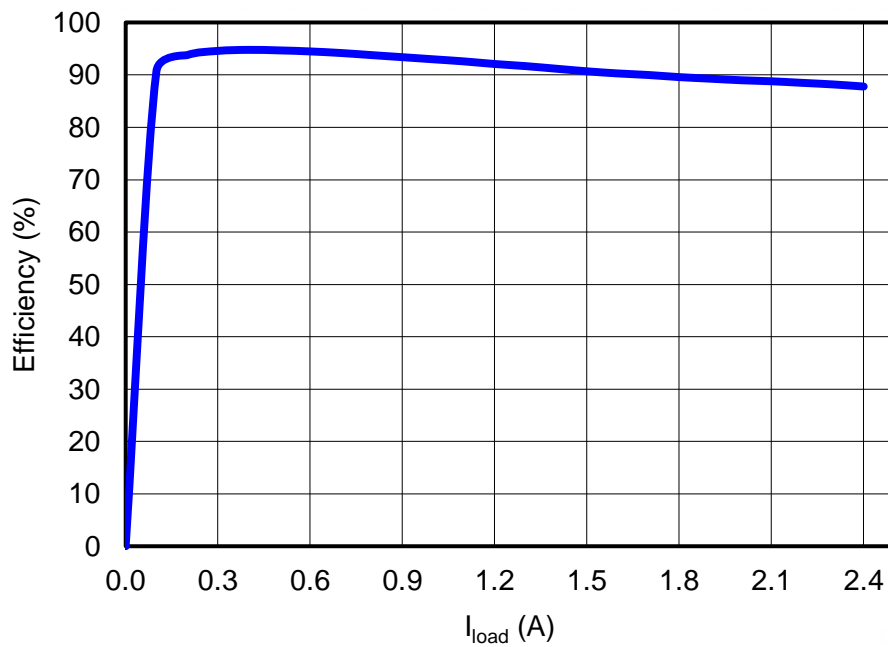

Figure 6. Efficiency Results of Buck2

4.3 Buck3 Efficiency

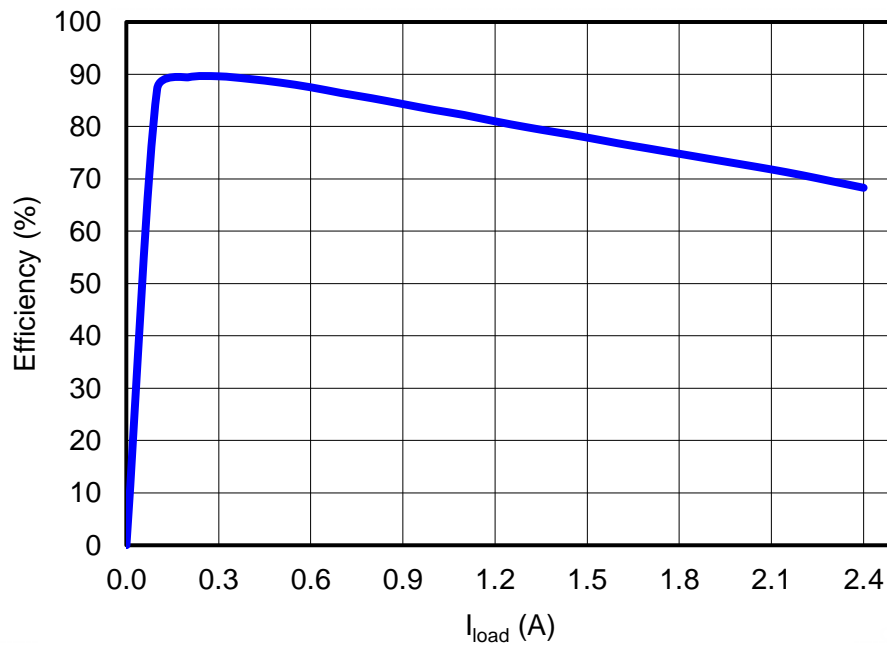

Figure 7. Efficiency Results of Buck3

4.4 BOOST Efficiency

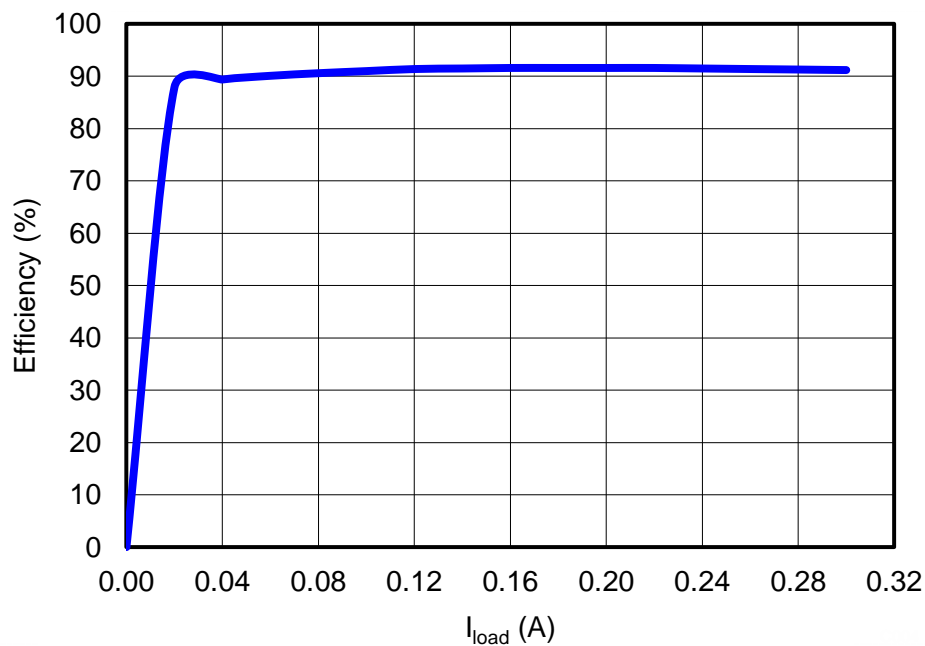

Figure 8. Efficiency Results of BOOST

5 Efficiency Test Summary

The efficiency of the TPS65310A-Q1 device was measured with the device placed on the TPS65310EVM. The device operated within the specified supply-voltage range and specified load range. Results for every convertor are shown in the preceding diagrams.

Revision History

| Changes from Original (October 2013) to A Revision | Page |
|---|-------------|
| • Deleted <i>Advanced Information</i> banner from document | 1 |
| • Changed reference to the TPS65381-Q1 and corresponding data sheet to the TPS65310A-Q1 and corresponding datasheet | 1 |
| • Changed hyperlink to TPS65381-Q1 data sheet to TPS65310A-Q1 datasheet | 2 |
| • Changed reference to the TPS65381EVM and corresponding User's Guide to the TPS65310EVM and corresponding User's Guide | 2 |
| • Changed board name in the head row of the <i>Application Data</i> table from TPS65310_EMC_Rev_C to TPS65310AEVM_Rev_C | 4 |
| • Added -Q1 to TPS65310A device name where missing | 6 |

NOTE: Page numbers for previous revisions may differ from page numbers in the current version.

IMPORTANT NOTICE

Texas Instruments Incorporated and its subsidiaries (TI) reserve the right to make corrections, enhancements, improvements and other changes to its semiconductor products and services per JESD46, latest issue, and to discontinue any product or service per JESD48, latest issue. Buyers should obtain the latest relevant information before placing orders and should verify that such information is current and complete. All semiconductor products (also referred to herein as "components") are sold subject to TI's terms and conditions of sale supplied at the time of order acknowledgment.

TI warrants performance of its components to the specifications applicable at the time of sale, in accordance with the warranty in TI's terms and conditions of sale of semiconductor products. Testing and other quality control techniques are used to the extent TI deems necessary to support this warranty. Except where mandated by applicable law, testing of all parameters of each component is not necessarily performed.

TI assumes no liability for applications assistance or the design of Buyers' products. Buyers are responsible for their products and applications using TI components. To minimize the risks associated with Buyers' products and applications, Buyers should provide adequate design and operating safeguards.

TI does not warrant or represent that any license, either express or implied, is granted under any patent right, copyright, mask work right, or other intellectual property right relating to any combination, machine, or process in which TI components or services are used. Information published by TI regarding third-party products or services does not constitute a license to use such products or services or a warranty or endorsement thereof. Use of such information may require a license from a third party under the patents or other intellectual property of the third party, or a license from TI under the patents or other intellectual property of TI.

Reproduction of significant portions of TI information in TI data books or data sheets is permissible only if reproduction is without alteration and is accompanied by all associated warranties, conditions, limitations, and notices. TI is not responsible or liable for such altered documentation. Information of third parties may be subject to additional restrictions.

Resale of TI components or services with statements different from or beyond the parameters stated by TI for that component or service voids all express and any implied warranties for the associated TI component or service and is an unfair and deceptive business practice. TI is not responsible or liable for any such statements.

Buyer acknowledges and agrees that it is solely responsible for compliance with all legal, regulatory and safety-related requirements concerning its products, and any use of TI components in its applications, notwithstanding any applications-related information or support that may be provided by TI. Buyer represents and agrees that it has all the necessary expertise to create and implement safeguards which anticipate dangerous consequences of failures, monitor failures and their consequences, lessen the likelihood of failures that might cause harm and take appropriate remedial actions. Buyer will fully indemnify TI and its representatives against any damages arising out of the use of any TI components in safety-critical applications.

In some cases, TI components may be promoted specifically to facilitate safety-related applications. With such components, TI's goal is to help enable customers to design and create their own end-product solutions that meet applicable functional safety standards and requirements. Nonetheless, such components are subject to these terms.

No TI components are authorized for use in FDA Class III (or similar life-critical medical equipment) unless authorized officers of the parties have executed a special agreement specifically governing such use.

Only those TI components which TI has specifically designated as military grade or "enhanced plastic" are designed and intended for use in military/aerospace applications or environments. Buyer acknowledges and agrees that any military or aerospace use of TI components which have **not** been so designated is solely at the Buyer's risk, and that Buyer is solely responsible for compliance with all legal and regulatory requirements in connection with such use.

TI has specifically designated certain components as meeting ISO/TS16949 requirements, mainly for automotive use. In any case of use of non-designated products, TI will not be responsible for any failure to meet ISO/TS16949.

Products

| | |
|------------------------------|--|
| Audio | www.ti.com/audio |
| Amplifiers | amplifier.ti.com |
| Data Converters | dataconverter.ti.com |
| DLP® Products | www.dlp.com |
| DSP | dsp.ti.com |
| Clocks and Timers | www.ti.com/clocks |
| Interface | interface.ti.com |
| Logic | logic.ti.com |
| Power Mgmt | power.ti.com |
| Microcontrollers | microcontroller.ti.com |
| RFID | www.ti-rfid.com |
| OMAP Applications Processors | www.ti.com/omap |
| Wireless Connectivity | www.ti.com/wirelessconnectivity |

Applications

| | |
|-------------------------------|--|
| Automotive and Transportation | www.ti.com/automotive |
| Communications and Telecom | www.ti.com/communications |
| Computers and Peripherals | www.ti.com/computers |
| Consumer Electronics | www.ti.com/consumer-apps |
| Energy and Lighting | www.ti.com/energy |
| Industrial | www.ti.com/industrial |
| Medical | www.ti.com/medical |
| Security | www.ti.com/security |
| Space, Avionics and Defense | www.ti.com/space-avionics-defense |
| Video and Imaging | www.ti.com/video |

TI E2E Community

e2e.ti.com