

# ADS8382EVM

This user's guide describes the characteristics, operation, and use of the ADS8382 18-bit, 600 kHz, high speed, serial interface Analog-to-Digital converter Evaluation Board (EVM). A complete circuit description, schematic diagram, and bill of materials are included.

The following related documents are available on the TI web site at [www.ti.com](http://www.ti.com).

<b>Data Sheets:</b>	<b>Literature Numbers:</b>
ADS8382	<a href="#">SLAS416</a>
REF1004C-2.5	<a href="#">SBVS002</a>
SN74AHC1G125	<a href="#">SCLS377</a>
THS4131	<a href="#">SLOS318</a>
OPA627AU	<a href="#">SBOS165</a>

## Contents

1	EVM Overview .....	2
2	Analog Interface.....	2
3	Digital Interface .....	4
4	Power Supplies .....	5
5	Using the EVM .....	6
6	ADS8382EVM Bill Of Materials .....	7
8	Board Layers .....	9
9	Schematics .....	11

## List of Figures

1	Input Buffer Circuit.....	3
2	Top Layer .....	9
3	Power Plane .....	9
4	Ground Plane .....	10
5	Bottom Layer.....	10

## List of Tables

1	Analog Input Connector .....	2
2	Jumper Setting .....	4
3	Pinout for Serial Control Connector P2 .....	5
4	Power Supply Test Points .....	5
5	Power Connector (J3) Pin Out .....	5
7	ADS8382EVM Bill of Materials.....	7

## 1 EVM Overview

### 1.1 Features

- Full-featured evaluation board for the ADS8382 18-bit, 600 kHz, single channel, high-speed serial-interface analog-to-digital converter (ADC)
- On board signal conditioning
- On board reference
- Input and output digital buffer

## 2 Analog Interface

The ADS8382EVM ships with buffer U13 configured in a unity-gain, single-ended to differential out configuration. The common-mode voltage pin of the THS4131 is factory set to 2.0 V on the evaluation module, and can be adjusted using potentiometer RP1. The potentiometer connects between the output of reference buffer U3 and ground. The single-ended input signal can be applied at pin-connector P1 pin 2 or via SMA connectors J2 (non-inverting input). The buffer circuit can be reconfigured for a fully differential input by installing resistors R4 and R31 and removing R16. The inverting leg of the differential signal can be connected to connector P1 pin 1 or SMA connector J1 (inverting input). See [Table 1](#) for the pinout of the analog connector, P1. See [Section 9](#) for the EVM schematic diagrams.

The analog-to-digital converter accepts a pseudo-bipolar differential input. A pseudo-bipolar differential signal is a differential signal that has a common-mode voltage such that each leg is always equal to or above zero volts. The common mode voltage should be half the reference voltage. The peak-to-peak amplitude on each input leg can be as large as the reference voltage.

**Table 1. Analog Input Connector**

Description	Signal Name	Connector pin#		Signal Name	Description
Inverting Input	-IN	P1.1	P1.2	+IN	Non-inverting Input
Reserved	N/A	P1.3	P1.4	N/A	Reserved
Reserved	N/A	P1.5	P1.6	N/A	Reserved
Reserved	N/A	P1.7	P1.8	N/A	Reserved
Pin tied to Ground	AGND	P1.9	P1.10	N/A	Reserved
Pin tied to Ground	AGND	P1.11	P1.12	N/A	Reserved
Reserved	N/A	P1.13	P1.14	N/A	Reserved
Pin tied to Ground	AGND	P1.15	P1.16	N/A	Reserved
Pin tied to Ground	AGND	P1.17	P1.18	N/A	Reserved
Reserved	N/A	P1.19	P1.20	REF+	External Reference Input

## 2.1 Signal Conditioning

It is a recommended practice to buffer the analog input to any SAR-type converter with a high-speed, low-noise amplifier with fast settling time. The amplifier circuit shown in Figure 1 is the buffer circuit used on the ADS8382EVM. This circuit consists of the THS4131, a high-speed, low-noise, fully differential amplifier configured as a single-ended in to differential out, unity gain buffer. This circuit was optimized to achieve the AC specifications (i.e., SNR, THD, SFDR, etc.) listed in the ADS8382 data sheet.

The type of input capacitors used in the signal path can make a few decibels of difference in AC performance. Polypropylene or C0G-type capacitors are recommended for the input signal path. Polypropylene capacitors cause the least distortion of the input signal and have excellent long-term stability, but are expensive and bulky. C0G ceramic capacitors cost less, come in smaller packages and perform as well as polypropylene capacitors in many applications, but are not as stable over time and temperature. The 68 pF and 6800 pF capacitors installed on the EVM are low-cost C0G type, manufactured by TDK Corporation.

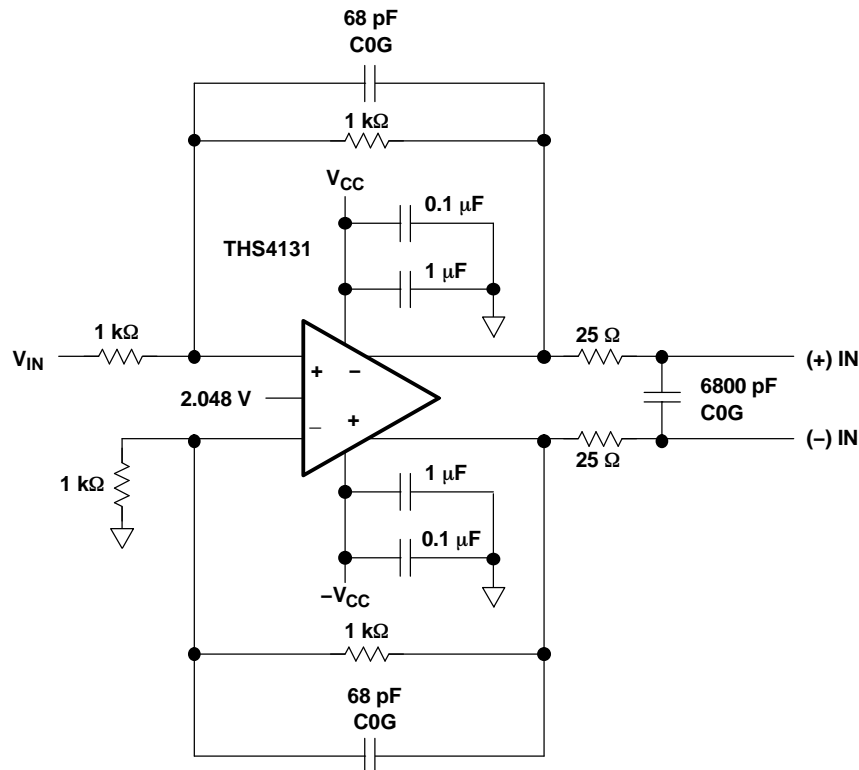

Figure 1. Input Buffer Circuit

## 2.2 Reference Voltage

The EVM allows the designer to select internal, on-board, or user-supplied reference-voltage sources. The internal reference is a 4.096 V reference voltage generated by the ADS8382 on pin 9. The on-board reference can be either a REF3040 (U1) or REF1004-2.5 (U14). The EVM ships with the REF1004-2.5 installed. The reference amplifier, U3, is set for a gain of 1.6, enabling it to take a 2.5 V input and output 4.1 V for use with the converter, or as part of the common-mode voltage circuit for the input buffer (U13). The user-supplied reference voltage is applied to connector P1 pin 20, and can be routed through the reference buffer and filtered, if desired. The EVM allows a number of configurations. Refer to [Table 1](#) for jumper settings, or the full schematic in [Section 9](#) for more information. The common footprint for U14 allows users to evaluate this converter with various reference ICs.

The EVM ships with the internal reference tied directly to the reference pin of the converter.

**Table 2. Jumper Setting**

Reference Designator	Description	Pins/Pads	
		1-2	2-3
SJP1	Buffer onboard reference (REF1004-2.5)	Shorted <sup>(1)</sup>	Open
	Buffer user supplied reference voltage applied at P1 pin 20.	Open	Shorted
SJP2	Connect external reference directly to SJP4	Shorted <sup>(1)</sup>	Open
	Connect buffered external reference to SJP4	Open	Shorted
SJP3	Connect U3 negative supply to ground	Shorted	Open
	Connect U3 negative supply to -VCC	Open	Shorted <sup>(1)</sup>
SJP4	Connect internal reference to REFIN	Shorted <sup>(1)</sup>	Open
	Connect external reference to REFIN	Open	Shorted
SJP5	Connect common-mode voltage to VOVM pin of THS4131	Shorted <sup>(1)</sup>	N/A
W1	Connect +5VD to BVDD	Shorted <sup>(1)</sup>	Open
	Connect +3.3VD to BVDD	Open	Shorted
W3	Set power down signal (PD) high	Shorted	N/A
W4	Set frame sync signal (FS) high	Shorted	N/A
W5	Set chip select signal (CS) low	Shorted <sup>(1)</sup>	N/A

<sup>(1)</sup> Factory Installed

## 3 Digital Interface

The ADS8382EVM is designed for easy interfacing to multiple platforms. Samtec plug and socket connectors provide a convenient dual row header/socket combination at P1 and P2 to plug into prototype boards or ribbon cable over to user system boards.

The digital input and output signals for the converter is available at connector P2 on the ADS8382EVM, see [Table 3](#) for the connector pinout.

**Table 3. Pinout for Serial Control Connector P2**

Description	Signal Name	Connector Pin		Signal Name	Description
Chip Select	$\overline{CS}$	P2.1	P2.2	N/A	Reserved
Serial Clock	SCLK	P2.3	P2.4	DGND	Ground
Reserved	N/A	P2.5	P2.6	N/A	Reserved
Frame Sync	FS	P2.7	P2.8	N/A	Reserved
Reserved	N/A	P2.9	P2.10	N/A	Reserved
Reserved	N/A	P2.11	P2.12	N/A	Reserved
Serial Data Out	SDO	P2.13	P2.14	N/A	Reserved
BUSY	BUSY	P2.15	P2.16	N/A	Reserved
Convert Start	$\overline{CONVST}$	P2.17	P2.18	DGND	Ground
Power down	PD	P2.19	P2.20	N/A	Reserved

#### 4 Power Supplies

The EVM accepts four power supplies

- A differential ( $\pm$ ) dc supply for the dual-supply op amps. The maximum recommended voltage is  $\pm 15$  Vdc
- A single +5.0 V dc supply for the analog section of the board (A/D + Reference).
- A single +5.0 V or +3.3 V dc supply for digital section of the board (A/D + buffers).

There are two ways to provide these voltages. The first is to connect the voltages to the test points listed in [Table 4](#).

**Table 4. Power Supply Test Points**

Test Point	Signal	Description
TP1	+VA	Connect +15.0 V dc supply for amplifier
TP2	-VA	Connect -15.0 V dc supply for amplifier
TP3	+BVDD	Apply +3.3 V dc or +5.0 V dc. See ADC data sheet for full range.
TP4	+AVCC	Apply +5.0 V dc

The second is to use the power connector J3, and derive the voltages elsewhere. [Table 5](#) gives the pinout for J3. If using this connector, set W1 jumper to connect +3.3VD or +5VD from J3 to +BVDD. Shunt pins 1-2 to select +5VD, or pins 2-3 to select +3.3VD as the source for the digital-buffer-voltage supply (+BVDD).

**Table 5. Power Connector (J3) Pin Out**

Signal	J1 Pin		Signal
+VA(+15V)	1	2	-VA(-15 V)
+5VA	3	4	N/C
DGND	5	6	AGND
N/C	7	8	N/C
+3.3VD	9	10	+5VD

## 5 Using the EVM

The ADS8382EVM serves three functions:

1. As a reference design
2. As a prototype board
3. As a software test platform

### 5.1 Reference Design

As a reference design, the ADS8382EVM contains the essential circuitry to showcase the analog-to-digital converter. This essential circuitry includes the input amplifier, reference circuit, and buffers. The EVM analog-input circuit is optimized for a 100-kHz input signal; therefore, users may need to adjust the resistor and capacitor values to accommodate higher frequencies. In ac-type applications where signal distortion is concern, polypropylene or COG type capacitors are recommended for use in the signal path.

Typical fully-differential amplifiers configured for single-ended in to differential out can distort the signal in an attempt to equalize the input pins. This distortion is specially evident when step inputs are applied. Therefore, users who will be applying a step input to the converter should use discrete amplifiers for the single-ended-to-differential conversion of the signal. The *Differential Input, Differential Output Configuration* circuit shown in the *Theory of Operation* section of the ADS8382 datasheet (literature number SLAS416) can be used. In applications where the input is continuous, the single amplifier solution using the THS4131, can effectively drive the converter inputs.

### 5.2 Prototype Board

As a prototype board, the buffer circuit has resistor pads for configuring the input as either single-ended or fully differential input. The input circuit can be modified to accommodate user prototype needs, whether it be evaluating another differential amplifier or limiting noise for best performance. The analog, power, and digital connectors can be made to plug into a standard 0.1" breadboard or ribbon cables to interface directly to FPGAs or processors.

### 5.3 Software Test Platform

As a software test platform, connectors P1 and P2 plug into the serial interface connectors of the 5-6K interface card. The 5-6K interface card plugs into the C5000 and C6000 Digital Signal Processor starter kits (DSK). Refer to the *5-6K Interface Card User's Guide* ([SLAU104](#)) for more information.

**6 ADS8382EVM Bill Of Materials**

The following table contains a complete bill of materials for the ADS8382EVM. The schematic diagram is also provided for reference. Contact the Product Information Center or email [dataconvapps@list.ti.com](mailto:dataconvapps@list.ti.com) for questions regarding this EVM.

**Table 7. ADS8382EVM Bill of Materials**

QTY	Value	Reference Designators	Footprint	Manufacturer	Manufacturer's Part Number	Description
1	49.9	R1	603	Panasonic - ECG or Alternate	ERJ-3EKF49R9V	RES 49.9 $\Omega$ 1/16 W 1% 0603 SMD
1	1.2 k $\Omega$	R2	603	Yageo America or Alternate	9C06031A1201FKHFT	RES 1.20 k $\Omega$ 1/10 W 1% 0603 SMD
4	NI	R3 R4 R5 R31	805	NOT INSTALLED	NOT INSTALLED	
8	100 $\Omega$	R6 R21 R22 R23 R24 R25 R26 R27	603	Panasonic - ECG or Alternate	ERJ-3EKF1000V	RES 100 $\Omega$ 1/16 W 1% 0603 SMD
1	100 $\Omega$	R7	805	Panasonic - ECG or Alternate	ERJ-6ENF1000V	RES 100 $\Omega$ 1/10 W 1% 0805 SMD
7	10 k $\Omega$	R8 R10 R11 R12 R13 R32 R39	603	Panasonic - ECG or Alternate	ERJ-3EKF1002V	RES 10.0K $\Omega$ 1/16 W 1% 0603 SMD
1	910 $\Omega$	R14	805	Panasonic - ECG or Alternate	ERJ-6GEYJ911V	RES 910 $\Omega$ 1/8 W 5% 0805 SMD
3	1 k $\Omega$	R15 R16 R17	805	Panasonic - ECG or Alternate	ERJ-6ENF1001V	RES 1.00 k $\Omega$ 1/10 W 1% 0805 SMD
1	768 $\Omega$	R18	603	Panasonic - ECG or Alternate	ERJ-3EKF7680V	RES 768 $\Omega$ 1/16 W 1% 0603 SMD
2	0 $\Omega$	R19 R36	603	Panasonic - ECG or Alternate	ERJ-3GEY0R00V	RES ZERO $\Omega$ 1/16 W 5% 0603 SMD
2	1 k $\Omega$	R28 R29	603	Panasonic - ECG or Alternate	ERJ-3EKF1001V	RES 1.00 k $\Omega$ 1/16 W 1% 0603 SMD
1	NI	R30	603	NOT INSTALLED	NOT INSTALLED	
2	24.9 $\Omega$	R33 R34	805	Panasonic - ECG or Alternate	ERJ-6ENF24R9V	RES 24.9 $\Omega$ 1/10 W 1% 0805 SMD
1	49.9 k $\Omega$	R35	805	Panasonic - ECG or Alternate	ERJ-6ENF4992V	RES 49.9 k $\Omega$ 1/10 W 1% 0805 SMD
2	0	R37 R38	1206	Panasonic - ECG or Alternate	ERJ-8GEY0R00V	RES 0 $\Omega$ 1/4 W 5% 1206 SMD
1	47 $\mu$ F	C1	1206	TDK Corporation or Alternate	C3216X5R0J476M	CAP CER 47 $\mu$ F 6.3 V X5R 20% 1206
5	1 $\mu$ F	C2 C3 C4 C5 C45	805	TDK Corporation or Alternate	C2012X7R1E105K	CAP CER 1.0 $\mu$ F 25 V X7R 0805 T/R
3	1 $\mu$ F	C6 C7 C44	603	TDK Corporation or Alternate	C1608X5R1A105KT	CAP CER 1.0 $\mu$ F 10 V X5R 10% 0603
15	0.1 $\mu$ F	C8 C9 C10 C11 C12 C13 C17 C18 C19 C20 C21 C22 C23 C26 C28	603	TDK Corporation or Alternate	C1608X7R1E104K	CAP CER 0.10 $\mu$ F 25 V X7R 10% 060
5	2.2 $\mu$ F	C14 C15 C24 C25 C27	603	TDK Corporation or Alternate	C1608X5R1A225MT	CAP CER 2.2 $\mu$ F 6.3 V X5R 20% 0603
5	NI	C29 C42	603	NOT INSTALLED	NOT INSTALLED	
9	0.01 $\mu$ F	C35 C36 C37 C38 C39 C40 C41 C55 C58	603	TDK Corporation or Alternate	C1608X7R1H103KT	CAP CER 10000 pF 50 V X7R 10% 0603
1	10 $\mu$ F	C34	3528	Kemet or Alternate	T491B106K016AS	CAPACITOR TANT 10 $\mu$ F 16 V 10% SMD
1	6800 $\mu$ F	C46 C43 C63	805	TDK Corporation or Alternate	C2012C0G1H682J	CAP CER 6800 pF 50 V C0G 5% 0805
4	10 $\mu$ F	C47 C48 C49 C50	1206	TDK Corporation or Alternate	C3216X5R1C106KT	CAP CER 10 $\mu$ F 16 V X5R 20% 1206
4	10 $\mu$ F	C51 C52 C53 C54	6032	Panasonic - ECG or Alternate	ECS-T1EC106R	CAP 10 $\mu$ F 25 V Tantalum TE SMD
2	68 pF	C32 C33	603	TDK Corporation or Alternate	C1608C0G1H680J	CAP CER 68 pF 50 V C0G 5% 0603
2	0.01 $\mu$ F	C56 C57	1206	TDK Corporation or Alternate	C3216X7R1H103KT	CAP 10000 pF 50 V CERAMIC X7R 1206
4	1000 pF	C59 C60 C61 C62 C64	603	TDK Corporation or Alternate	C1608C0G1H102KT	CAP CER 1000 pF 50 V C0G 0603 T/R
2	NI	C30 C31	805	NOT INSTALLED	NOT INSTALLED	1/10 W 0805 Chip resistor

**Table 7. ADS8382EVM Bill of Materials (continued)**

QTY	Value	Reference Designators	Footprint	Manufacturer	Manufacturer's Part Number	Description
1	10 kΩ	RP1	BOURNS_3296Y	Bourns Inc.	3296Y-1-103	POT 10 kΩ 3/8" SQ CERM SL MT
4		L1 L2 L3 L4	805	TDK Corporation	MMZ2012R601A	FERRITE CHIP 600 Ω 500 mA 0805
2	NI	U1 U2	3-SOT-23	NOT INSTALLED	NOT INSTALLED	REF3040 50 ppm/°C, 50 μA in SOT23-3 CMOS voltage reference
1		U3	8-SOP(D)	Texas Instruments	OPA627AU	DiFet amplifier
7		U5 U6 U7 U8 U9 U10 U11	5-SOT(DBV)	Texas Instruments	SN74AHC1G125DBVR	Single bus buffer gate/line driver with 3-state output
1	ADS8382	U12	28-PQFP(QFN)	Texas Instruments	ADS8382IBRHPT	ADS8382 18-bit serial 600 ksps
1	THS4131	U13	8-SOP(D)	Texas Instruments	THS4131ID	High-speed low noise, fully differential I/O amplifiers
1	REF1004-2.5	U14	8-SOP(D)	Texas Instruments	REF1004C-2.5	2.5 V Micropower voltage reference
1	3POS_JUMPER	W1	3pos_jump	Samtec	TSW-103-07-L-S	3 Position jumper _ 0.1" spacing
3	2POS_JUMPER	W3 W4 W5	2pos_jump	Samtec	TSW-102-07-L-S	2 Position jumper _ 0.1" spacing
1	SJP2	SJP5	SJP2	NOT INSTALLED	NOT INSTALLED	Pad 2 position jumper
4	SJP3	SPJ1 SPJ2 SPJ3 SPJ4	SJP3	NOT INSTALLED	NOT INSTALLED	Pad 3 position jumper
2	SMA_PCB_MT	J1 J2	SMA_JACK	Johnson Components Inc.	142-0701-301	Right angle SMA connector
1	Power supply	J3	5x2x0.1_ SMT_SOCKET	Samtec	SSW-105-22-S-D-VS	0.025" SMT socket - bottom side of PWB
1				Samtec	TSM-105-01-T-D-V-P	0.025" SMT plug - top side of PWB
2	10x2x0.1	P1 P2	10x2x0.1_ SMT_LPUG_ &_SOCKET	Samtec	SSW-110-22-S-D-VS	0.025" SMT socket - bottom side of PWB
2				Samtec	TSM-110-01-T-D-V-P	0.025" SMT plug - top side of PWB
10	TP_0.025	TP1 TP2 TP3 TP4 TP5 TP6 TP7 TP8 TP11 TP12	test_point2	Keystone Electronics	5000K-ND	Test point PC MINI 0.040"D black
4	TP_0.25	TP10 TP13 TP9 TP14	test_point2	Keystone Electronics	5001K-ND	Test point PC MINI 0.040"D black



8 Board Layers

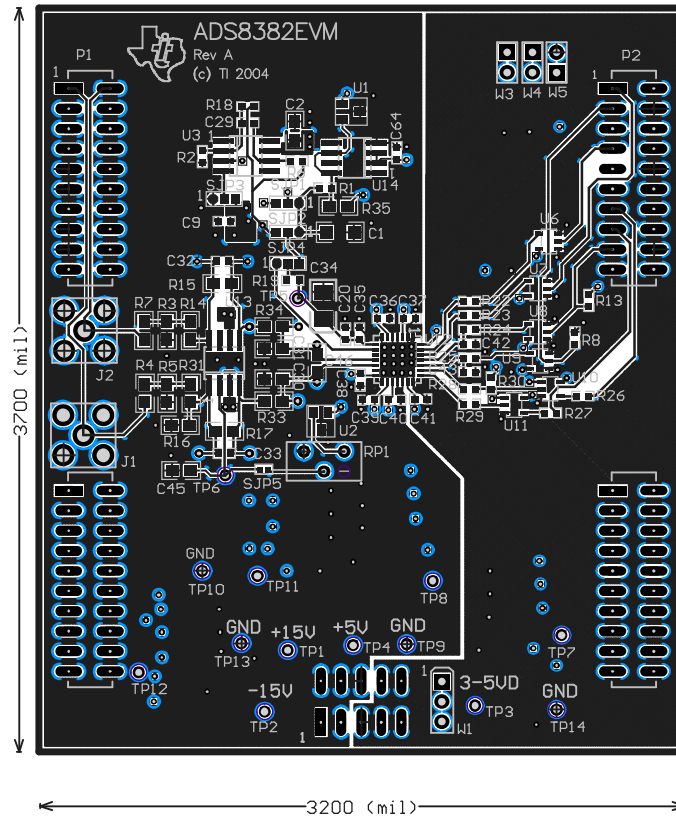

Figure 2. Top Layer

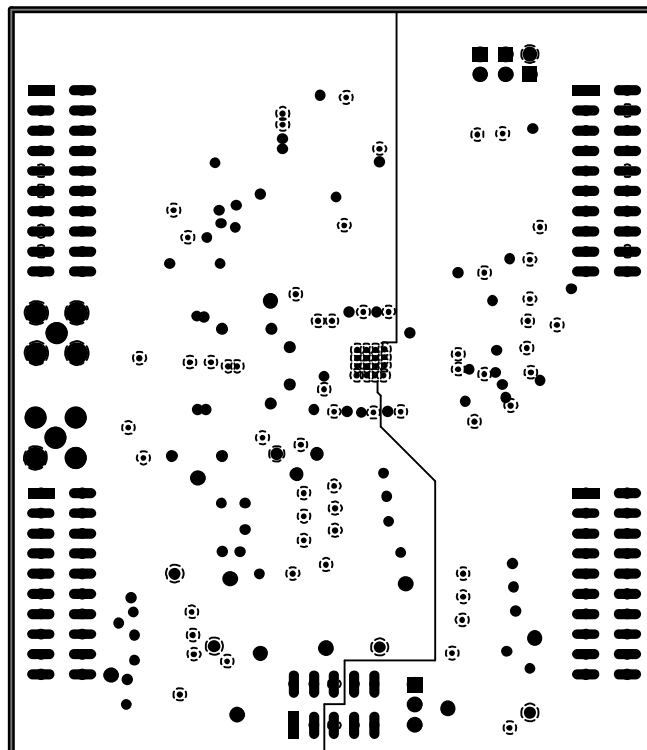

Figure 3. Power Plane

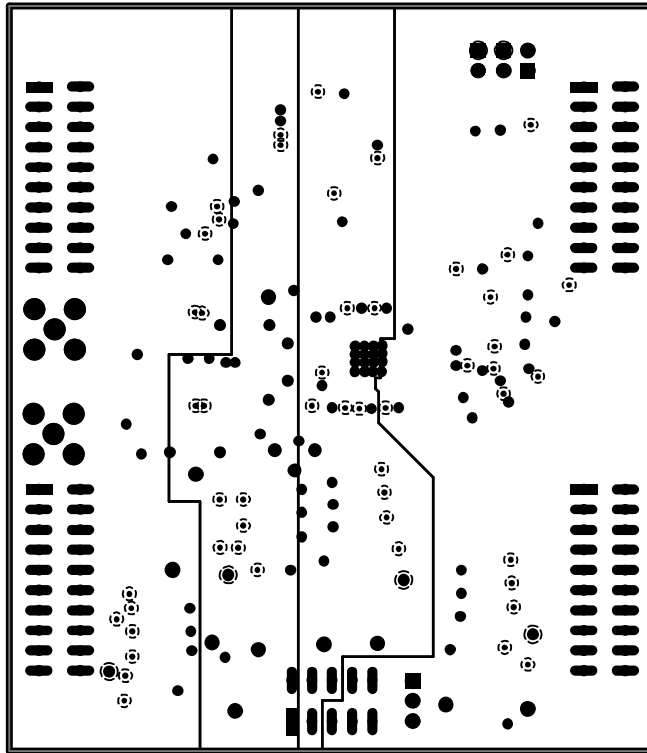

Figure 4. Ground Plane

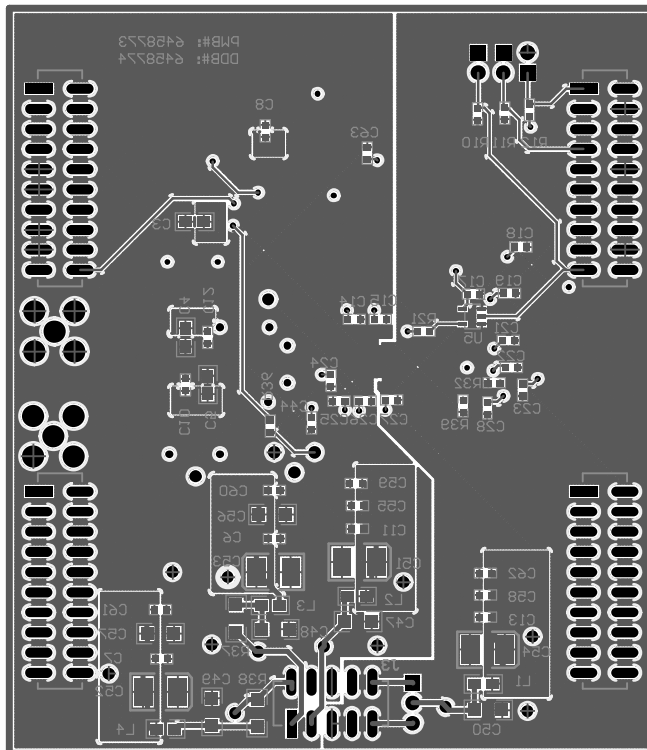
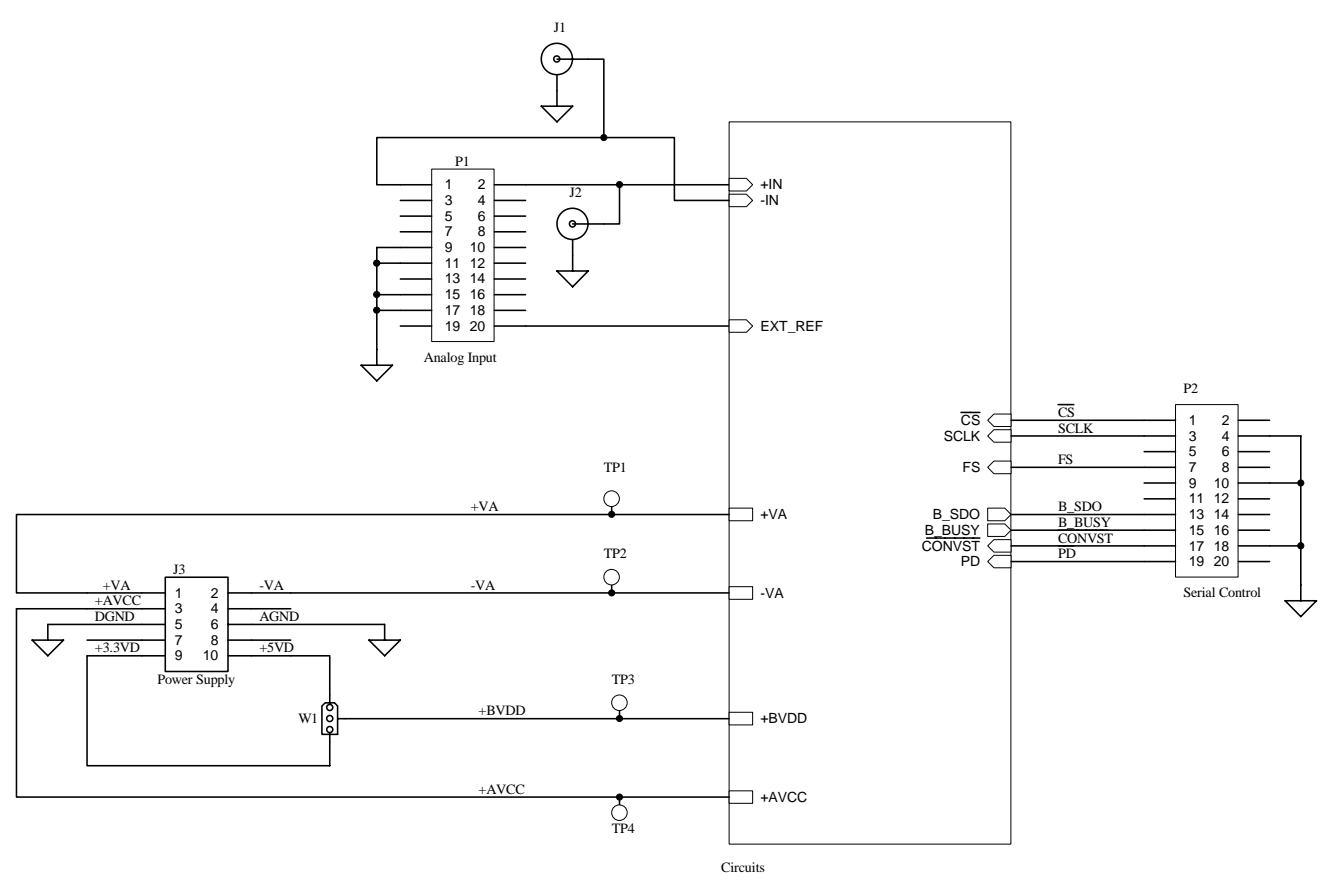

Figure 5. Bottom Layer

## **9 Schematics**

Schematic diagrams are appended following this page.

Revision History		
REV	ECN Number	Approved



**TEXAS INSTRUMENTS**  
 12500 TI Boulevard, Dallas, Texas 75243

TITLE: ADS8372EVM/ADS8382EVM

Engineer: Lijoy Philipose	DOCUMENT CONTROL #: 6458774	REV: A
Drawn By: Lijoy Philipose	DATE: 30-Jun-2005	SIZE: SHEET: 1 OF: 2

Engineer: Lijoy Philipose	DOCUMENT CONTROL #: 6458774	REV: A
Drawn By: Lijoy Philipose	DATE: 30-Jun-2005	SIZE: SHEET: 1 OF: 2

Revision History		
REV	ECN Number	Approved

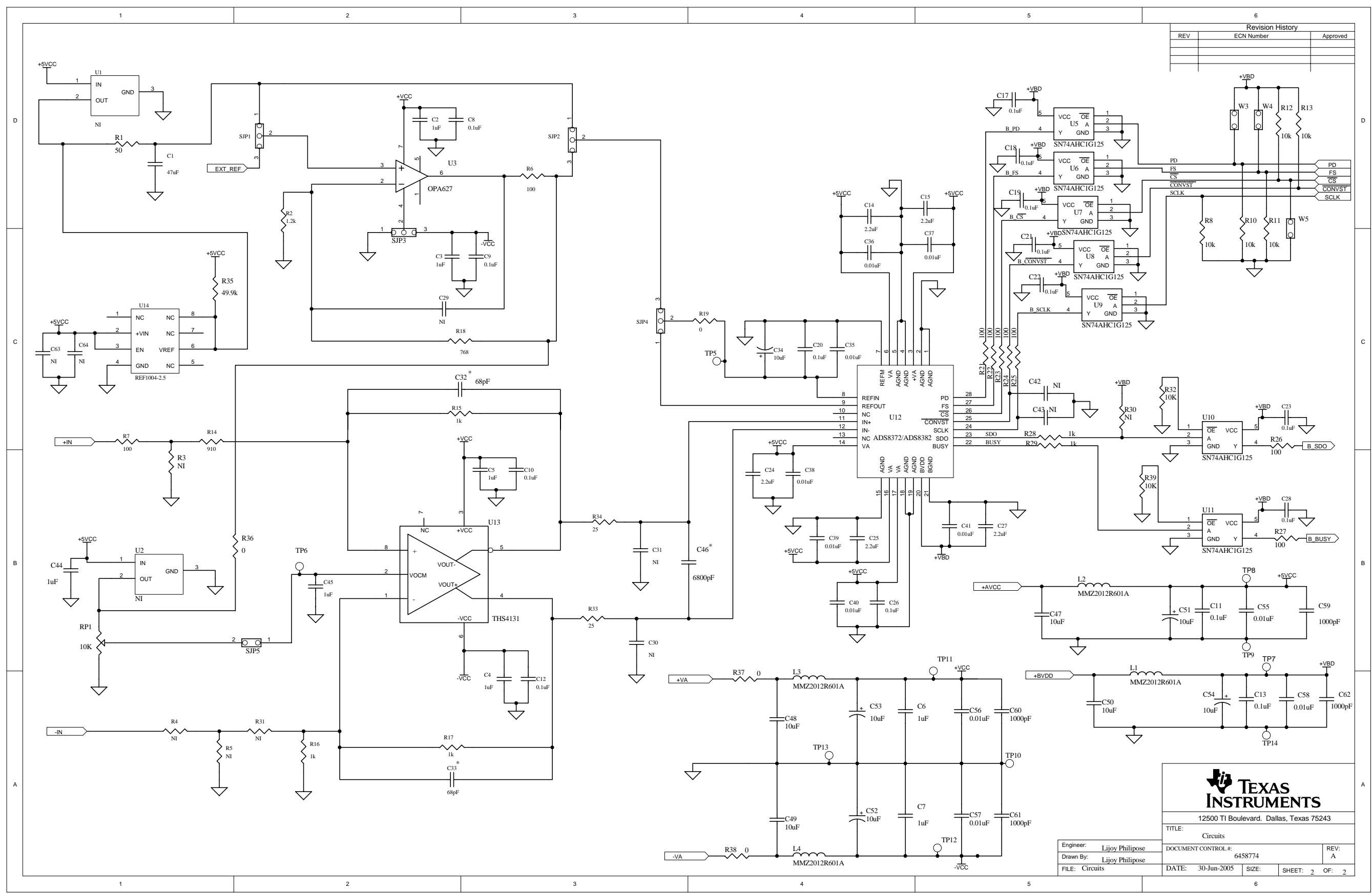

12500 TI Boulevard, Dallas, Texas 75243

TITLE:	Circuits	
DOCUMENT CONTROL #:	6458774	
DATE:	30-Jun-2005	SIZE:
SHEET:	2	OF:
REV:	A	

Engineer: Lijoy Philipose  
 Drawn By: Lijoy Philipose  
 FILE: Circuits

## IMPORTANT NOTICE

Texas Instruments Incorporated and its subsidiaries (TI) reserve the right to make corrections, modifications, enhancements, improvements, and other changes to its products and services at any time and to discontinue any product or service without notice. Customers should obtain the latest relevant information before placing orders and should verify that such information is current and complete. All products are sold subject to TI's terms and conditions of sale supplied at the time of order acknowledgment.

TI warrants performance of its hardware products to the specifications applicable at the time of sale in accordance with TI's standard warranty. Testing and other quality control techniques are used to the extent TI deems necessary to support this warranty. Except where mandated by government requirements, testing of all parameters of each product is not necessarily performed.

TI assumes no liability for applications assistance or customer product design. Customers are responsible for their products and applications using TI components. To minimize the risks associated with customer products and applications, customers should provide adequate design and operating safeguards.

TI does not warrant or represent that any license, either express or implied, is granted under any TI patent right, copyright, mask work right, or other TI intellectual property right relating to any combination, machine, or process in which TI products or services are used. Information published by TI regarding third-party products or services does not constitute a license from TI to use such products or services or a warranty or endorsement thereof. Use of such information may require a license from a third party under the patents or other intellectual property of the third party, or a license from TI under the patents or other intellectual property of TI.

Reproduction of information in TI data books or data sheets is permissible only if reproduction is without alteration and is accompanied by all associated warranties, conditions, limitations, and notices. Reproduction of this information with alteration is an unfair and deceptive business practice. TI is not responsible or liable for such altered documentation.

Resale of TI products or services with statements different from or beyond the parameters stated by TI for that product or service voids all express and any implied warranties for the associated TI product or service and is an unfair and deceptive business practice. TI is not responsible or liable for any such statements.

Following are URLs where you can obtain information on other Texas Instruments products and application solutions:

<b>Products</b>		<b>Applications</b>	
Amplifiers	<a href="http://amplifier.ti.com">amplifier.ti.com</a>	Audio	<a href="http://www.ti.com/audio">www.ti.com/audio</a>
Data Converters	<a href="http://dataconverter.ti.com">dataconverter.ti.com</a>	Automotive	<a href="http://www.ti.com/automotive">www.ti.com/automotive</a>
DSP	<a href="http://dsp.ti.com">dsp.ti.com</a>	Broadband	<a href="http://www.ti.com/broadband">www.ti.com/broadband</a>
Interface	<a href="http://interface.ti.com">interface.ti.com</a>	Digital Control	<a href="http://www.ti.com/digitalcontrol">www.ti.com/digitalcontrol</a>
Logic	<a href="http://logic.ti.com">logic.ti.com</a>	Military	<a href="http://www.ti.com/military">www.ti.com/military</a>
Power Mgmt	<a href="http://power.ti.com">power.ti.com</a>	Optical Networking	<a href="http://www.ti.com/opticalnetwork">www.ti.com/opticalnetwork</a>
Microcontrollers	<a href="http://microcontroller.ti.com">microcontroller.ti.com</a>	Security	<a href="http://www.ti.com/security">www.ti.com/security</a>
		Telephony	<a href="http://www.ti.com/telephony">www.ti.com/telephony</a>
		Video & Imaging	<a href="http://www.ti.com/video">www.ti.com/video</a>
		Wireless	<a href="http://www.ti.com/wireless">www.ti.com/wireless</a>

Mailing Address: Texas Instruments  
Post Office Box 655303 Dallas, Texas 75265