

# ***TLV320AIC23 EVM2***

***Evaluation Platform for the TLV320AIC23 Stereo  
Audio CODEC and TLV320DAC23 Stereo DAC***

## *User's Guide*

## IMPORTANT NOTICE

Texas Instruments Incorporated and its subsidiaries (TI) reserve the right to make corrections, modifications, enhancements, improvements, and other changes to its products and services at any time and to discontinue any product or service without notice. Customers should obtain the latest relevant information before placing orders and should verify that such information is current and complete. All products are sold subject to TI's terms and conditions of sale supplied at the time of order acknowledgment.

TI warrants performance of its hardware products to the specifications applicable at the time of sale in accordance with TI's standard warranty. Testing and other quality control techniques are used to the extent TI deems necessary to support this warranty. Except where mandated by government requirements, testing of all parameters of each product is not necessarily performed.

TI assumes no liability for applications assistance or customer product design. Customers are responsible for their products and applications using TI components. To minimize the risks associated with customer products and applications, customers should provide adequate design and operating safeguards.

TI does not warrant or represent that any license, either express or implied, is granted under any TI patent right, copyright, mask work right, or other TI intellectual property right relating to any combination, machine, or process in which TI products or services are used. Information published by TI regarding third-party products or services does not constitute a license from TI to use such products or services or a warranty or endorsement thereof. Use of such information may require a license from a third party under the patents or other intellectual property of the third party, or a license from TI under the patents or other intellectual property of TI.

Reproduction of information in TI data books or data sheets is permissible only if reproduction is without alteration and is accompanied by all associated warranties, conditions, limitations, and notices. Reproduction of this information with alteration is an unfair and deceptive business practice. TI is not responsible or liable for such altered documentation.

Resale of TI products or services with statements different from or beyond the parameters stated by TI for that product or service voids all express and any implied warranties for the associated TI product or service and is an unfair and deceptive business practice. TI is not responsible or liable for any such statements.

Mailing Address:

Texas Instruments  
Post Office Box 655303  
Dallas, Texas 75265

## EVM IMPORTANT NOTICE

Texas Instruments (TI) provides the enclosed product(s) under the following conditions:

This evaluation kit being sold by TI is intended for use for **ENGINEERING DEVELOPMENT OR EVALUATION PURPOSES ONLY** and is not considered by TI to be fit for commercial use. As such, the goods being provided may not be complete in terms of required design-, marketing-, and/or manufacturing-related protective considerations, including product safety measures typically found in the end product incorporating the goods. As a prototype, this product does not fall within the scope of the European Union directive on electromagnetic compatibility and therefore may not meet the technical requirements of the directive.

Should this evaluation kit not meet the specifications indicated in the EVM User's Guide, the kit may be returned within 30 days from the date of delivery for a full refund. **THE FOREGOING WARRANTY IS THE EXCLUSIVE WARRANTY MADE BY SELLER TO BUYER AND IS IN LIEU OF ALL OTHER WARRANTIES, EXPRESSED, IMPLIED, OR STATUTORY, INCLUDING ANY WARRANTY OF MERCHANTABILITY OR FITNESS FOR ANY PARTICULAR PURPOSE.**

The user assumes all responsibility and liability for proper and safe handling of the goods. Further, the user indemnifies TI from all claims arising from the handling or use of the goods. Please be aware that the products received may not be regulatory compliant or agency certified (FCC, UL, CE, etc.). Due to the open construction of the product, it is the user's responsibility to take any and all appropriate precautions with regard to electrostatic discharge.

**EXCEPT TO THE EXTENT OF THE INDEMNITY SET FORTH ABOVE, NEITHER PARTY SHALL BE LIABLE TO THE OTHER FOR ANY INDIRECT, SPECIAL, INCIDENTAL, OR CONSEQUENTIAL DAMAGES.**

TI currently deals with a variety of customers for products, and therefore our arrangement with the user **is not exclusive**.

TI assumes **no liability for applications assistance, customer product design, software performance, or infringement of patents or services described herein**.

Please read the EVM User's Guide and, specifically, the EVM Warnings and Restrictions notice in the EVM User's Guide prior to handling the product. This notice contains important safety information about temperatures and voltages. For further safety concerns, please contact the TI application engineer.

Persons handling the product must have electronics training and observe good laboratory practice standards.

No license is granted under any patent right or other intellectual property right of TI covering or relating to any machine, process, or combination in which such TI products or services might be or are used.

Mailing Address:

Texas Instruments  
Post Office Box 655303  
Dallas, Texas 75265

## **EVM WARNINGS AND RESTRICTIONS**

It is important to operate this EVM within the input voltage range of 0–1.5 V and the output voltage range of 0 V and 3.6 V.

Exceeding the specified input range may cause unexpected operation and/or irreversible damage to the EVM. If there are questions concerning the input range, please contact a TI field representative prior to connecting the input power.

Applying loads outside of the specified output range may result in unintended operation and/or possible permanent damage to the EVM. Please consult the EVM User's Guide prior to connecting any load to the EVM output. If there is uncertainty as to the load specification, please contact a TI field representative.

During normal operation, some circuit components may have case temperatures greater than 50°C. The EVM is designed to operate properly with certain components above 50°C as long as the input and output ranges are maintained. These components include but are not limited to linear regulators, switching transistors, pass transistors, and current sense resistors. These types of devices can be identified using the EVM schematic located in the EVM User's Guide. When placing measurement probes near these devices during operation, please be aware that these devices may be very warm to the touch.

### **Mailing Address:**

Texas Instruments  
Post Office Box 655303  
Dallas, Texas 75265

# Read This First

---

---

---

---

### ***About This Manual***

This user's guide describes the setup and operation of the TLV320AIC23 EVM2 evaluation platform, and installation and operation of the DASCCT\_AIC23 software that drives the EVM.

### ***How to Use This Manual***

This document contains the following chapters:

Chapter 1 – *Introduction*

Chapter 2 – *Quick Start-Up*

Chapter 3 – *Theory of Operation*

Chapter 4 – *Software*

Chapter 5 – *I<sup>2</sup>C Error Messages*

Chapter 6 – *Kit Contents*

Appendix A – *Circuit Card and Schematic*

### ***Related Documentation From Texas Instruments***

*TLV320DAC23 Stereo Audio D/A Converter, 8- to 96-kHz With Integrated Headphone Amplifier* Data Manual – Literature No. SLES001

*TLV320AIC23 Stereo Audio CODEC, 8- to 96-kHz, With Integrated Headphone Amplifier* Data Manual – Literature No. SLWS106

### ***FCC Warning***

This equipment is intended for use in a laboratory test environment only. It generates, uses, and can radiate radio frequency energy and has not been tested for compliance with the limits of computing devices pursuant to subpart

## *Trademarks*

---

J of part 15 of FCC rules, which are designed to provide reasonable protection against radio frequency interference. Operation of this equipment in other environments may cause interference with radio communications, in which case the user at his own expense will be required to take whatever measures may be required to correct this interference.

## ***Trademarks***

Windows is a trademark of Microsoft Corporation.  
All other trademarks are the property of their respective owners.

# Contents

---

---

---

<b>1</b>	<b>Introduction</b>	<b>1-1</b>
<b>2</b>	<b>Quick Start-Up</b>	<b>2-1</b>
<b>3</b>	<b>Theory of Operation</b>	<b>3-1</b>
3.1	Photographs of EVM	3-3
3.2	Jumper Settings	3-6
3.3	TLV320AIC23 EVM2 Power	3-6
3.4	Analog Connections	3-6
3.4.1	Microphone	3-6
3.4.2	LINE IN Connections	3-6
3.4.3	Headphones	3-6
3.4.4	LINE OUT Connectors	3-6
3.5	Digital I/O	3-7
3.6	TLV320AIC23 EVM2 Features	3-7
3.6.1	Master Clock	3-7
3.6.2	Digital Loopback	3-7
3.6.3	Software Interface Connection	3-7
<b>4</b>	<b>Software</b>	<b>4-1</b>
4.1	DASCCT_AIC23 Installation	4-2
4.2	DASCCT_AIC23 Start-Up	4-4
4.3	DASCCT_AIC23 Overview	4-4
4.4	Main Panel	4-4
4.4.1	<i>About</i> Button	4-4
4.4.2	<i>AIC 23</i> and <i>DAC 23</i> Radio Buttons	4-4
4.4.3	<i>Master</i> and <i>Slave</i> Radio Buttons	4-4
4.4.4	Message Area	4-5
4.4.5	Line Input Volume	4-5
4.4.6	HeadPhone Volume	4-5
4.4.7	<i>RESET</i> Button	4-5
4.4.8	<i>EXIT</i> Button	4-5
4.4.9	<i>I2C Adjust</i> Button	4-6
4.4.10	<i>I2C Bypass</i> Check Box	4-6
4.4.11	<i>DataLog On</i> Check Box	4-6
4.4.12	<i>View Registers</i> Button	4-6
4.4.13	<i>Dig Loopback</i> Check Box	4-6
4.4.14	<i>Digital Control</i> Button	4-6
4.4.15	<i>Analog Control</i> Button	4-6

4.4.16	<i>Format Control</i> Button	4-6
4.4.17	<i>Normal Mode</i> and <i>USB Mode</i> Radio Buttons	4-6
4.4.18	<i>Clock Select</i> Button	4-7
4.4.19	Frequency Display Areas	4-7
4.5	I <sup>2</sup> C Adjust	4-7
4.6	View Registers	4-8
4.6.1	Preset Modes	4-8
4.6.2	L Vol (Line Input) Register	4-10
4.6.3	R Vol (Line Input) Register	4-10
4.6.4	L Vol (HeadPhone) Register	4-10
4.6.5	R Vol (HeadPhone) Register	4-10
4.6.6	<i>OK</i> , <i>Apply</i> , and <i>Cancel</i> Buttons	4-10
4.6.7	Audio (Analog) Register	4-10
4.6.8	Audio (Digital) Register	4-11
4.6.9	Power Down Register	4-12
4.6.10	Audio (Format) Register	4-12
4.6.11	Sampling Rate Register	4-13
4.6.12	Interface Activate Register	4-14
<b>5</b>	<b>I<sup>2</sup>C Error Messages</b>	<b>5-1</b>
<b>6</b>	<b>Kit Contents</b>	<b>6-1</b>
6.1	TLV320AIC23 EVM2 Kit Contents	6-2
6.2	Bill of Materials	6-3
<b>A</b>	<b>Circuit Card and Schematic</b>	<b>A-1</b>

## Figures

3-1	TLV320AIC23 EVM2 Parts Location Diagram	3-2
3-2	TLV320AIC23 EVM2 Top View	3-3
3-3	TLV320AIC23 EVM2 Bottom View	3-4
3-4	Parallel Port Interface Board Top View	3-5
3-5	Parallel Port Interface Board Bottom View	3-5
4-1	AIC23/DAC23 EVM2 Connection Diagram	4-3
4-2	Main Panel	4-4
4-3	I <sup>2</sup> C Adjust	4-7
4-4	Register GUI	4-8
4-5	Mode Files	4-9
4-6	Analog Control	4-11
4-7	Digital Control	4-12
4-8	Format Control	4-13
4-9	Clock Setup	4-14



# Introduction

---

---

---

---

The TLV320AIC23 EVM2 is designed to demonstrate the TLV320AIC23 codec or TLV320DAC23 DAC. With the use of the DAREF106R2 parallel port interface board, the user can control the EVM with a PC. The supplied software allows the user to change items such as volume, sample rate, power-down modes, and audio format on the fly. The user can also change the path of the audio using the GUI. The user can view all the registers and their values and change the values using the GUI. To accommodate the various sample rates, the EVM has a crystal socket allowing the user to change the MASTER CLOCK frequency. For inputs, a MIC jack and a LINEIN jack (stereo and LEFT/RIGHT) are available on the EVM. For outputs, HEADPHONE and LINEOUT (stereo and LEFT/RIGHT) are available on the EVM. Using the GUI interface, the user can change between USB and NORMAL modes, allowing various oversampling rates.

The user can choose from several configurations to evaluate the AIC23 product. Using the digital loopback option, the user can input an analog signal (i.e., CD), perform ADC conversions, and then route the digital result into the DAC and send the resulting analog signal to LINEOUT or HEADPHONE, completing the loopback operation. Also available are configurations to perform RECORD (ADC) and PLAYBACK (DAC) operations.

The AIC23 and DAC23 can be configured for bypass mode and sidetone mode.



# Quick Start-Up

---

---

---

---

This section explains to the user how to set up the TLV320AIC23 EVM2 quickly and hear audio using digital loopback.

- 1) Set the jumpers for the appropriate conditions as explained in Section 3.2
- 2) Power up the AIC23 (PJ1) per Section 3.3
- 3) Connect audio source (e.g., CD player) LINEIN (J1).
- 4) Connect speaker or headphone to J4.
- 5) Connect the parallel port interface board to the PC parallel port and, via the supplied cable, the miniDIN 8-pin jack, J5.
- 6) Run DASCCT\_AIC23 from your PC.
- 7) When the GUI appears, select the AIC23 radio button (upper left-hand corner), and check the Dig Loopback check box (bottom, left of center).
- 8) Audio will be heard from the speakers or headphones.
- 9) Adjust the volume, using either the HeadPhone Volume or Line Input Volume controls.



# Theory of Operation

---

---

---

---

This section provides a comprehensive description and explanation of the various features of the TLV320AIC23 EVM2.

<b>Topic</b>	<b>Page</b>
<b>3.1 Photographs of EVM</b> .....	<b>3-3</b>
<b>3.2 Jumper Settings</b> .....	<b>3-6</b>
<b>3.3 TLV320AIC23 EVM2 Power</b> .....	<b>3-6</b>
<b>3.4 Analog Connections</b> .....	<b>3-6</b>
<b>3.5 Digital I/O</b> .....	<b>3-7</b>
<b>3.6 TLV320AIC23 EVM2 Features</b> .....	<b>3-7</b>

Figure 3–1. TLV320AIC23 EVM2 Parts Location Diagram

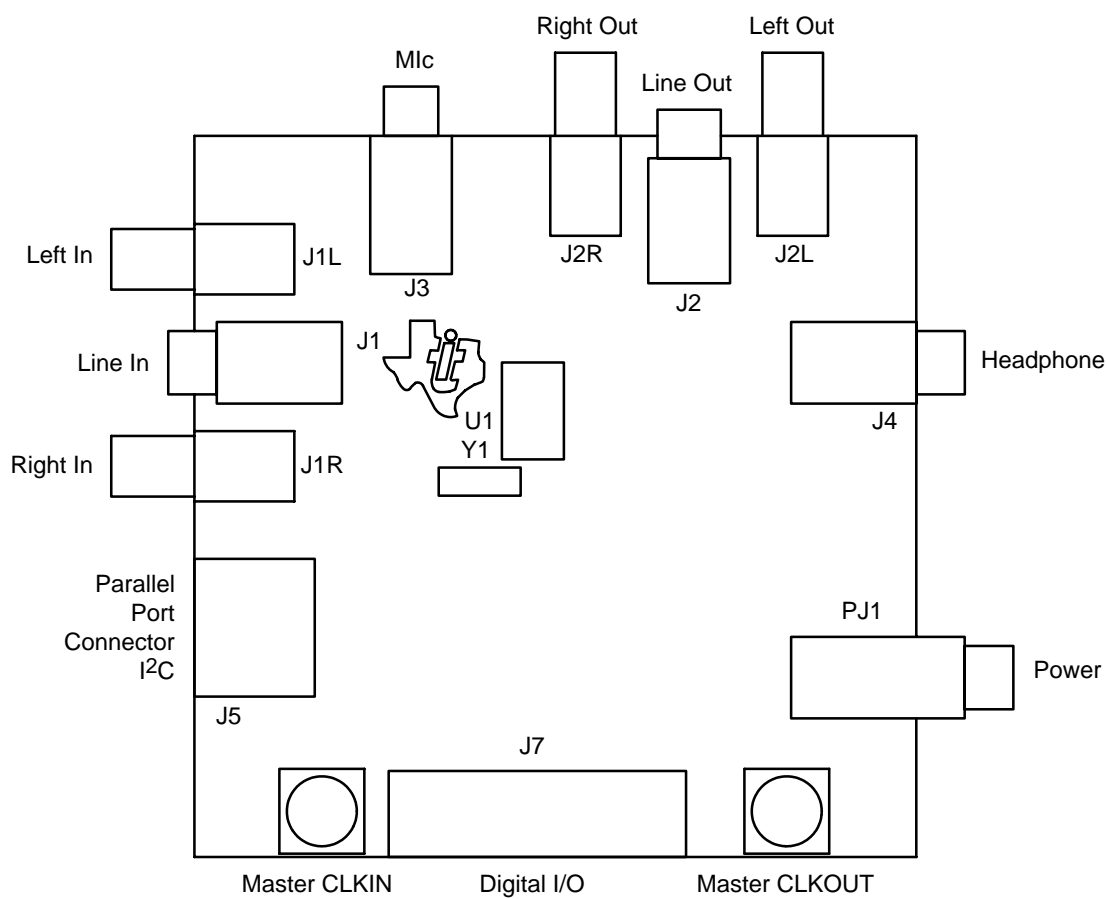

### 3.1 Photographs of EVM

Figure 3–2. TLV320AIC23 EVM2 Top View

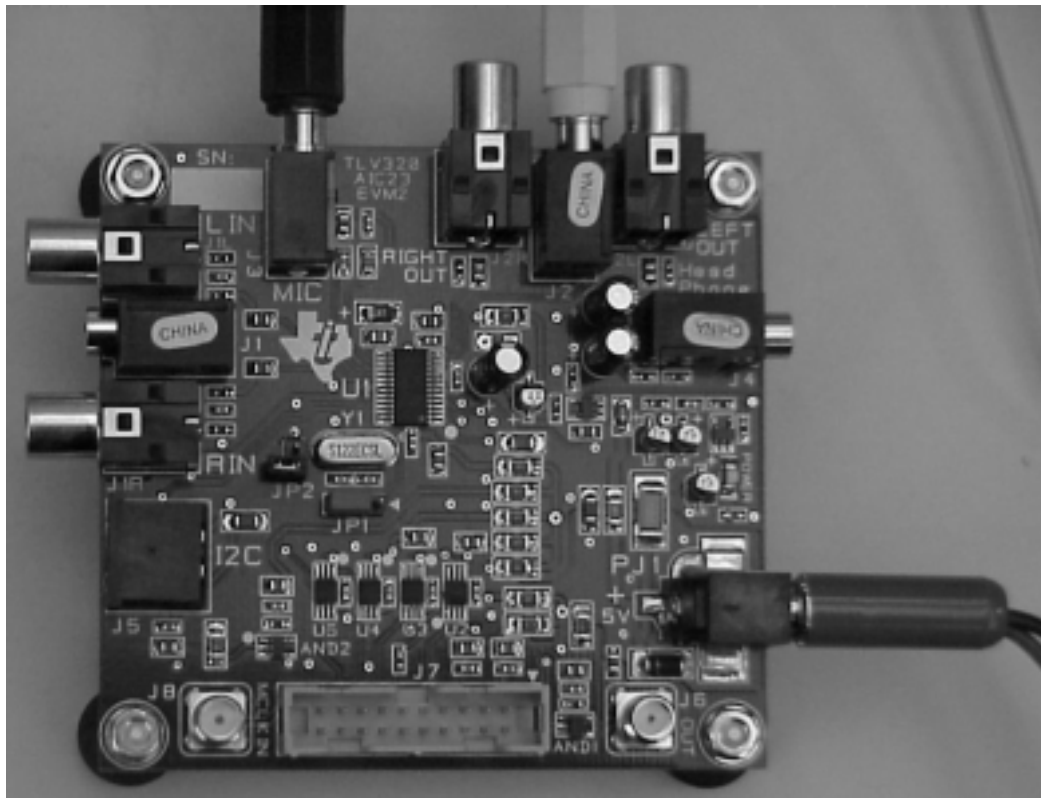

Figure 3–3. TLV320AIC23 EVM2 Bottom View

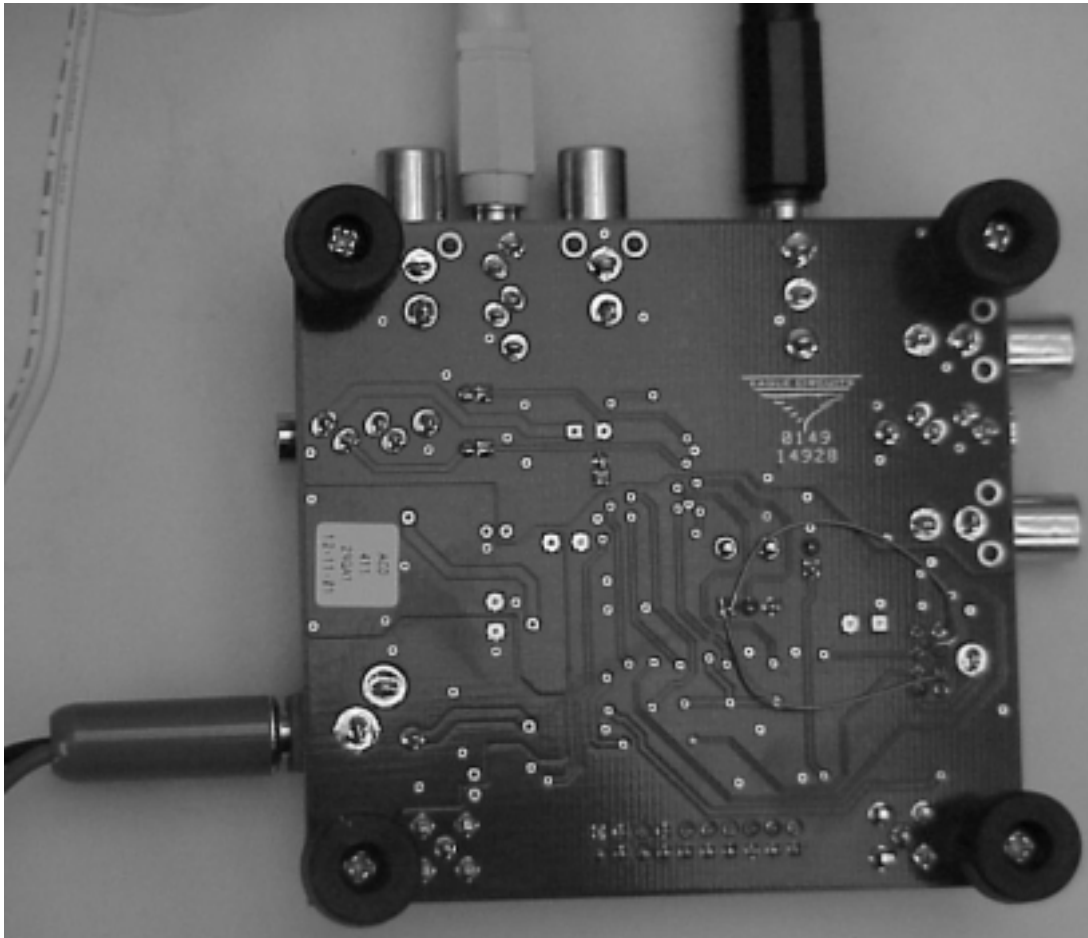



Figure 3–4. Parallel Port Interface Board Top View

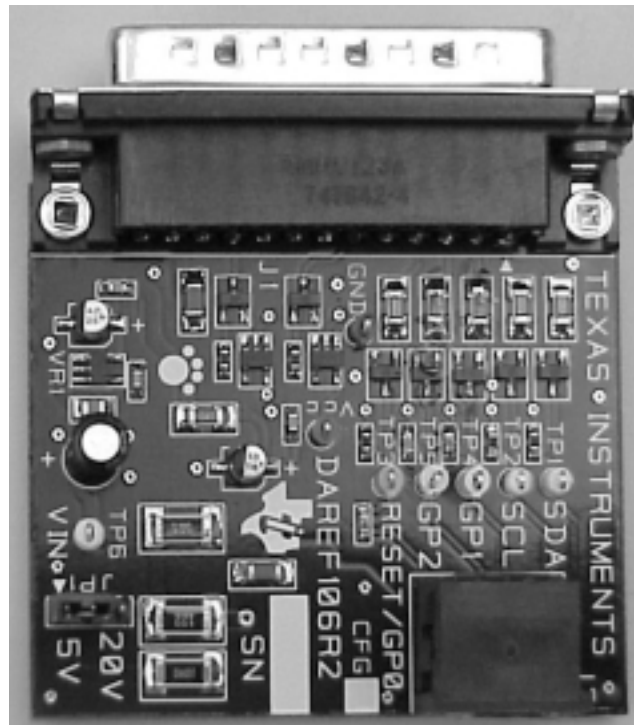
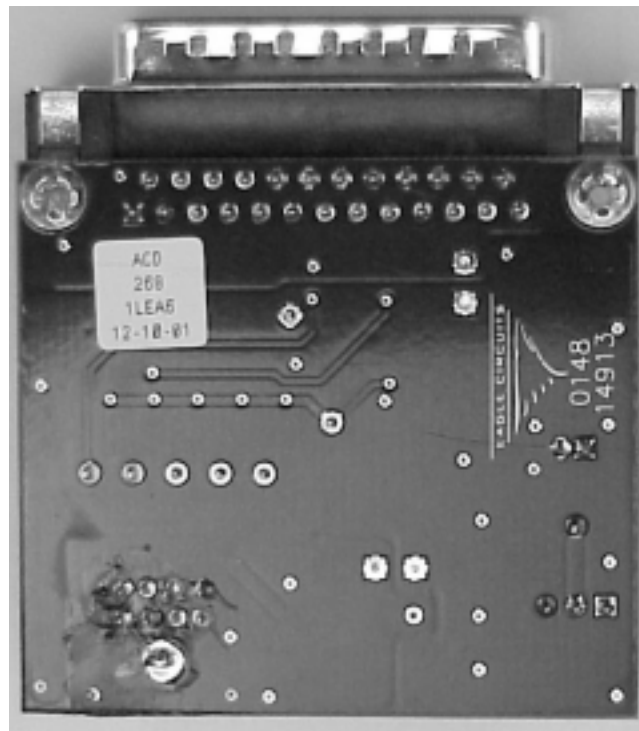

Figure 3–5. Parallel Port Interface Board Bottom View



## 3.2 Jumper Settings

There are two jumpers on the EVM.

- JP1 is used to select the communication mode of the EVM. Position 1–2 sets the mode for SPI. Position 2–3 sets the mode for I<sup>2</sup>C. The GUI software was developed for I<sup>2</sup>C communication. For SPI the end-user needs to create the necessary code. Signals needed for SPI are available on the EVM.
- JP2 is used to select or deselect the onboard crystal for MASTER CLOCK.

Choose one of the following jumper configurations before applying power to the EVM:

MASTER CLOCK SOURCE	JP2	Y1
Master clock from onboard crystal	OUT	IN
Master clock supplied externally	IN	OUT

## 3.3 TLV320AIC23 EVM2 Power

The TLV320AIC23 EVM2 is powered by an external 5-Vdc power supply (not included) to a 2,5-mm mini power jack, PJ1. LED1 indicates when power is applied to the board.

## 3.4 Analog Connections

### 3.4.1 Microphone

A 3,5-mm mono jack is available for the microphone input, J3.

### 3.4.2 LINE IN Connections

A 1.0-V rms (max) input is available at the LINE IN jacks. Two connection types are available.

- Independent left/right RCA jacks, J1L and J1R.
- 3,5-mm stereo mini jack, J1.

### 3.4.3 Headphones

A headphone connection is available at J4 for 16- or 32-Ω loads. J4 is a 3,5-mm stereo mini jack.

### 3.4.4 LINE OUT Connectors

A 1.0-V rms (max) output is available at the LINE OUT jacks. Two connection types are available.

- Independent left/right RCA jacks, J2L and J2R.
- 3,5-mm stereo mini jack, J2.

### 3.5 Digital I/O

A protected header, J7, is available for interfacing with external digital I/O. Two power sources, 5 V and 3.3 V, are available on J7 for powering external boards. The 5-V power is tapped directly off PJ1. The 3.3-V power can supply up to 100 mA.

Signal	J7
5v_DIO (5.0 VDC)	1, 2
VCC_DIO (3.0 VDC)	5, 6
DIN	9
DOUT	11
BCLK	13
LRCIN	15
LRCOUT	17
MCLK	19
DIGITAL GROUND	3, 4, 7, 8, 10, 12, 14, 16, 18, 20

### 3.6 TLV320AIC23 EVM2 Features

#### 3.6.1 Master Clock

The master clock can be either external or internal. For internal mode, a crystal socket is available. For external mode, the master clock is applied to SMA jack J8. The master clock input is 5-V tolerant. The master clock output is available at SMA jack J6. The master clock is derived from the CLKOUT pin (U1 pin 2). This signal has a 5-V swing.

#### 3.6.2 Digital Loopback

Digital loopback can be enabled using the GUI. This loops DOUT to DIN via a MUX.

#### 3.6.3 Software Interface Connection

A PC provides control of the TLV320AIC23 EVM2 via a software GUI called Rhino. A parallel port interface board, DAREF106, connects to the PC parallel port. A cable with miniDIN 8-pin connectors, included in the TLV320AIC23 EVM2 kit, connects the parallel port interface board to the EVM.



# Software

---

---

---

---

This section describes the use of the DASCCT\_AIC23 software GUI interface to control the TLV320AIC23 EVM2 board. Pictures of the various interface panels are shown, and explanations of the control and display elements on each are provided.

<b>Topic</b>	<b>Page</b>
4.1 DASCCT_AIC23 Installation .....	4-2
4.2 DASCCT_AIC23 Start-Up .....	4-4
4.3 DASCCT_AIC23 Overview .....	4-4
4.4 Main Panel .....	4-4
4.5 I <sup>2</sup> C Adjust .....	4-7
4.6 View Registers .....	4-8

## 4.1 DASCCT\_AIC23 Installation

Before running the DASCCT\_AIC23 software, the parallel port must be configured for enhanced parallel port (EPP). The parallel port configuration can be changed in the system setup during system boot up. Some computers have a bidirectional mode, which also works. (Some have PS2, which may also work.) The connection diagram for the equipment is Figure 4–1.

- 1) Insert the software CD labeled DASCCT\_AIC23 1.0 into the CD-ROM drive of the PC.
- 2) Open the Start menu and then click Run.
- 3) Type `D:\SETUP` and press <ENTER>. If the CD-ROM drive is not `D:`, substitute the appropriate drive letter. Follow the instructions presented by the setup wizard.
- 4) Connect the analog input from a CD, DVD player, or any alternative analog source to the TLV320AIC23/DAC23 EVM2.
- 5) Connect the TLV320AIC23/DAC23 EVM2 to the speakers or headphones that will be used for listening.
- 6) Connect the parallel port interface card to the parallel port connector of the PC.
- 7) Connect the cable provided in the kit between I<sup>2</sup>C connector J5 on the TLV320AIC23/DAC23 EVM2 and connector J2 on the parallel port interface card.

Figure 4-1. AIC23/DAC23 EVM2 Connection Diagram

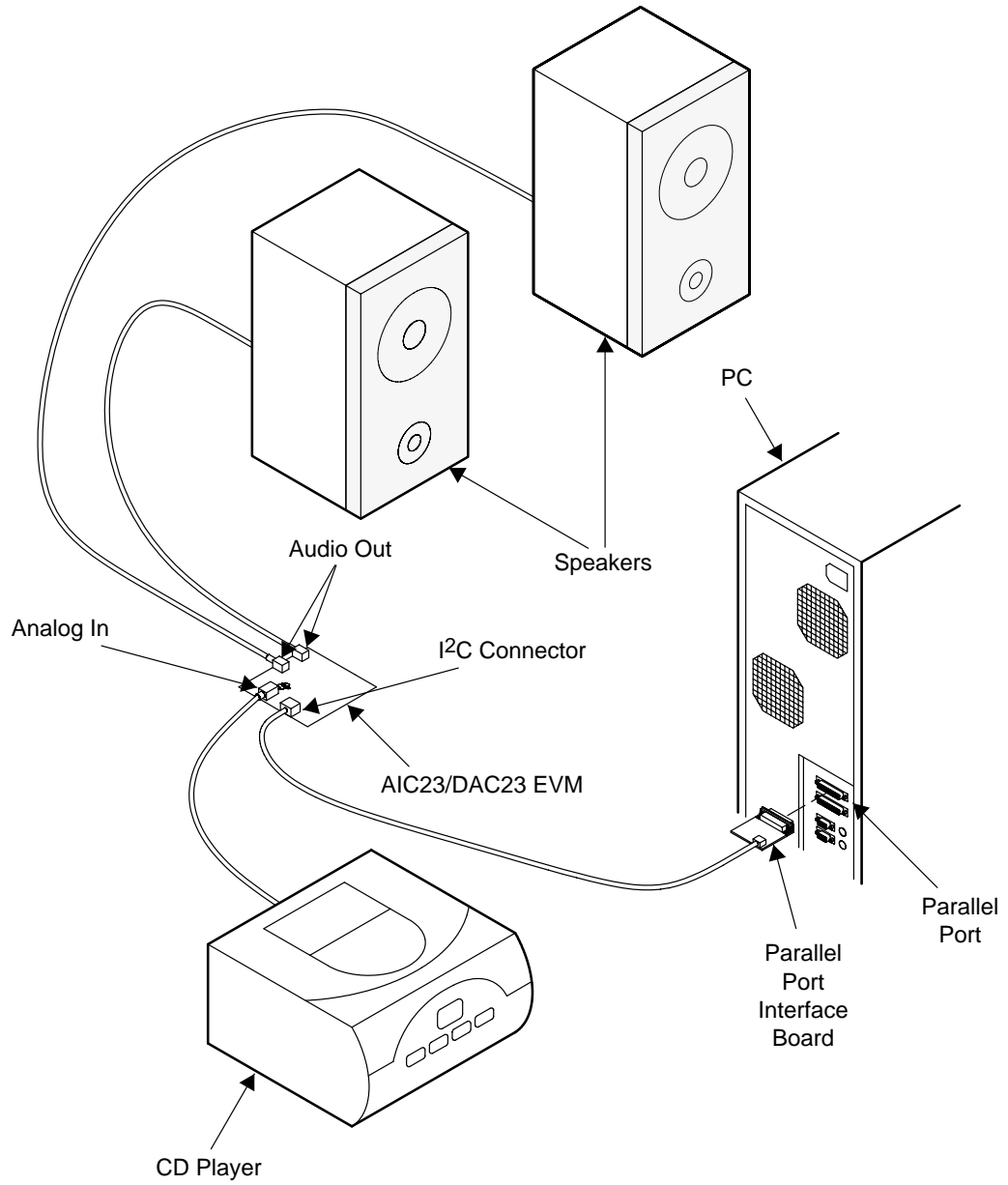

## 4.2 DASCCT\_AIC23 Start-Up

- 1) Execute the software file named DASCCT\_AIC23.exe from the directory where the software was loaded.
- 2) Click the *Master* or *Slave* radio button to select the operating mode.
- 3) Click the *AIC 23* or *DAC 23* radio button to select the device.

## 4.3 DASCCT\_AIC23 Overview

The EQ GUI was designed with a screen resolution of 1152 by 864. Therefore, the windows optimally fit on the screen using this resolution. For a screen resolution of 800 by 600, the main window initializes higher up, toward the center of the screen. All other resolutions initialize at the same coordinates as designed in the 1152 by 864 screen resolution.

## 4.4 Main Panel

The GUI main panel is shown in Figure 4–2. The following paragraphs describe the features seen on the main panel.

Figure 4–2. Main Panel

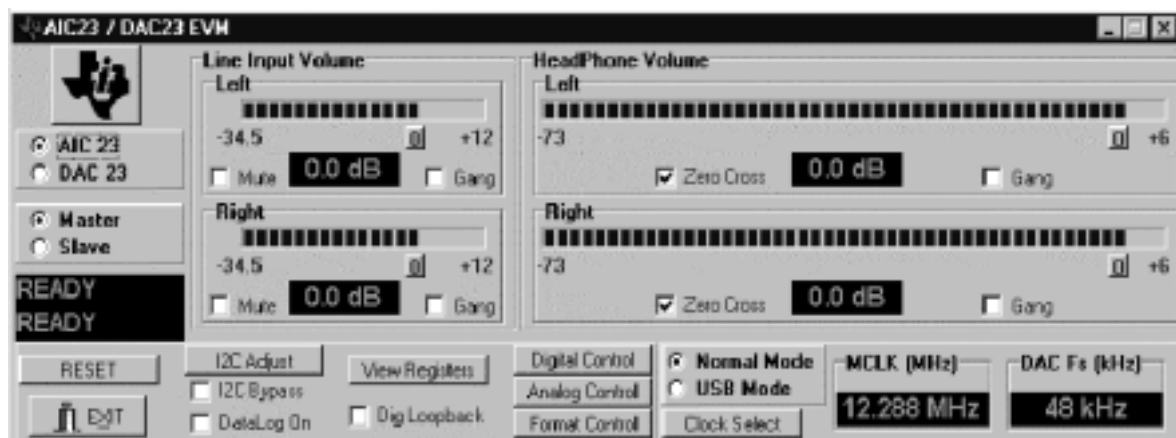

### 4.4.1 About Button

The *About* button is hidden under the TI logo in the upper left corner of the main panel. Pressing this button causes a standard *About* box to appear with release information about DASCCT\_AIC23.

### 4.4.2 AIC 23 and DAC 23 Radio Buttons

These radio button allow selection of the device to be emulated by the TLV320AIC23 EVM2, the codec or the DAC.

### 4.4.3 Master and Slave Radio Buttons

These radio buttons select the operating mode of the device.



#### 4.4.4 Message Area

Directly below the *Master* and *Slave* radio buttons on the left side of the main panel is a message area. Short text instructions to the operator, status indications, or error messages can appear in this box. A listing of possible error messages appears in Chapter 5, along with an explanation of the errors.

#### 4.4.5 Line Input Volume

The line input volume section of the main panel consists of two identical boxes, one each for the left and right input channels. Each box contains the following:

- A level bar that indicates the volume level. To set the volume, click at the desired location; the length of the bar adjusts to that point, changing the volume level accordingly.
- A *Mute* check box to silence the channel
- A *Gang* check box to tie the volume controls of both channels together. The channel that has its *Gang* box checked automatically locks the opposite channel into a volume setting the same as its own.
- A display area with a numeric readout of the actual gain level setting in dB

Left and right line input volume settings can also be changed in the L Vol (Line Input) and R Vol (Line Input) registers on the register panel (see Section 4.6.2 and Section 4.6.3, respectively).

#### 4.4.6 HeadPhone Volume

The headphone volume section of the main panel consists of two identical boxes, one each for the left and right audio channels. Each box contains the following:

- A level bar that indicates the volume level. To set the volume, click at the desired location; the length of the bar adjusts to that point, changing the volume level accordingly.
- A *Zero Cross* check box. When the zero-cross detect circuit for the headphone is enabled, the volume control values are only updated when the input signal to the gain stage is close to the analog ground level.
- A *Gang* check box to tie the volume controls of both channels together. The channel that has its *Gang* box checked automatically locks the opposite channel into a volume setting the same as its own.
- A display area with a numeric readout of the actual gain level setting in dB

Left and right headphone volume settings can also be changed in the L Vol (HeadPhone) and R Vol (HeadPhone) registers on the register panel (see Section 4.6.4 and Section 4.6.5, respectively).

#### 4.4.7 RESET Button

The *RESET* button sends an I<sup>2</sup>C reset command to the AIC23/DAC23.

#### 4.4.8 EXIT Button

*EXIT* closes all files. The *EXIT* button can be clicked at any time.

#### 4.4.9 I2C Adjust Button

Pressing this button opens a panel that allows adjustment of the timing period used for I<sup>2</sup>C communications between the PC and the EVM. See Section 4.5.

#### 4.4.10 I2C Bypass Check Box

This check box allows the user to run the software without a device connected to the parallel port.

#### 4.4.11 DataLog On Check Box

This check box allows the user to record the information sent over I<sup>2</sup>C. The data is always stored in a file called DataLog.txt. The { within the file represents a valid I<sup>2</sup>C start command. The } within the file represents a valid I<sup>2</sup>C stop command.

#### 4.4.12 View Registers Button

When the *View Registers* button is clicked, the GUI opens a second panel. This panel shows all the TLV320AIC23/DAC23 EVM2 registers. A function name is displayed for each bit in each register, and the values of the bits can be viewed or changed. A complete description including all the registers and other functionality of the second panel is in Section 4.6.

#### 4.4.13 Dig Loopback Check Box

Checking this box connects DOUT to DIN via a multiplexer.

#### 4.4.14 Digital Control Button

Clicking the *Digital Control* button opens a panel that allows setting of the digital audio controls (see Section 4.6.8). The digital audio controls can also be set by putting values directly into the *Audio (Digital)* register on the *Registers* panel (see Section 4.6).

#### 4.4.15 Analog Control Button

Clicking the *Analog Control* button opens a panel that allows setting of the analog audio controls (see Section 4.6.7). The analog audio controls can also be set by putting values directly into the *Audio (Analog)* register on the *Registers* panel (see Section 4.6).

#### 4.4.16 Format Control Button

Clicking the *Format Control* button opens a panel that allows setting of the audio format controls (see Section 4.6.10). The audio format controls can also be set by putting values directly into the *Audio (Format)* register on the *Registers* panel (see Section 4.6).

#### 4.4.17 Normal Mode and USB Mode Radio Buttons

For information on the proper setting of normal or USB mode, see the TLV320AIC23 data manual.

#### 4.4.18 Clock Select Button

Clicking the *Clock Select* button opens a panel that allows selection of master clock speed and ADC and DAC sampling rates (see Section 4.6.11). (Do clock selections correspond to sampling rate register bits?)

#### 4.4.19 Frequency Display Areas

In the lower right corner of the main panel are two frequency displays. The one on the left shows the master clock frequency MCLK in megaHertz; the one on the right shows the DAC sampling frequency in kiloHertz.

### 4.5 I<sup>2</sup>C Adjust

The I<sup>2</sup>C commands are generated on the parallel port using a method referred to as bit-banging. Because Windows™ does not have readily accessible timers down into the microseconds, the I<sup>2</sup>C clocks are done using C++ for-loops to create the delay. The number of executions of the for-loop is calibrated initially when the program is started. This initial calibration sets SCL to 100 kHz. The looping variable in the for-loop can be changed using the SCL period ◀ and ▶ buttons, which only become active after clicking the *Fine Adjust* button. To see the result of changing this variable, requires capturing the SCL output on a storage oscilloscope. The program recalibrates SCL to 100 kHz if the *RECALIBRATE* button is pressed.

Figure 4–3. I<sup>2</sup>C Adjust

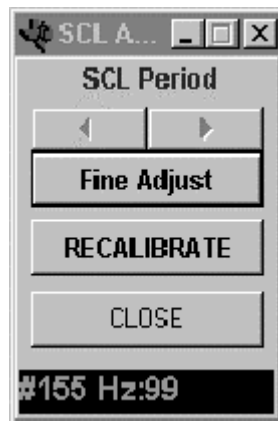

## 4.6 View Registers

The registers panel, shown in Figure 4–4, displays the bits for 10 registers, where the user can either view or change the bit values. There is a *Preset Modes* section of the panel, which allows the user to call up any of three sets of default register settings. A section with *OK*, *Apply*, and *Cancel* buttons completes the registers panel. The various functions are discussed individually in the following sections.

Figure 4–4. Register GUI

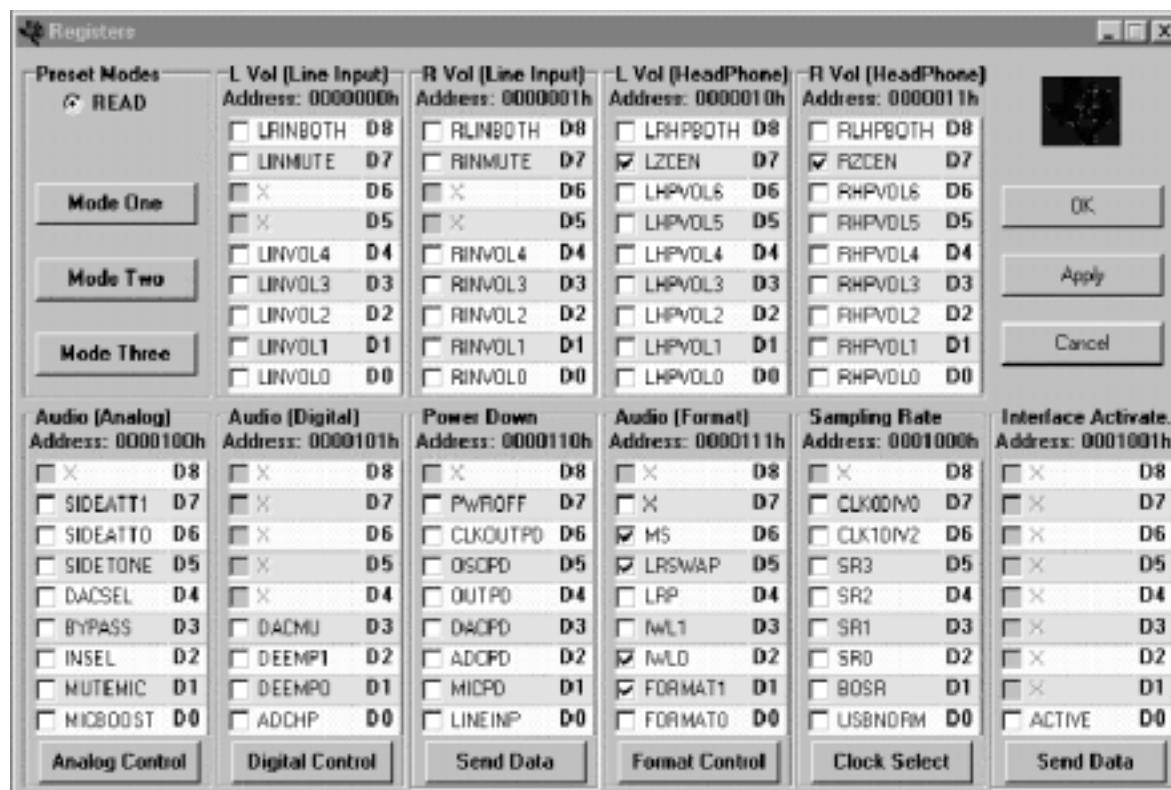

### 4.6.1 Preset Modes

The *Preset Modes* section of the panel contains a *READ* radio button that is currently inactive. Functionality will be assigned to the button in a future software release. There are also three buttons labelled *Mode One*, *Mode Two*, and *Mode Three*. Each button corresponds with an ASCII text file containing preset register values. When a button is clicked, the values in the corresponding file are loaded into the DASCCT\_AIC23 registers.

The three standard files that come with the software are shown in Figure 4–5. The files can be edited, but must be kept in the same directory where the DASCCT\_AIC23.exe file is stored. The first column in the file is the decimal value of the register number and the second column is the register value, followed by an explanatory comment.

Figure 4–5. Mode Files

```

ModeOne.txt - Notepad
File Edit Search Help
0 0 // Left Vol Line Trackbar in dB
1 0 // Right Vol Line Trackbar in dB
2 0 // Left Vol HP Trackbar in dB
3 0 // Right Vol HP Trackbar in dB
4 16 // Analog Register setting in decimal
5 00 // Digital Register setting in decimal
6 00 // Power Down Register setting in decimal
7 64 // Format Register setting in decimal
8 00 // Sampling Rate Register setting in decimal
9 01 // Interface Activate Register setting in decimal

```

```

ModeTwo.txt - Notepad
File Edit Search Help
0 -20 // Left Vol Line Trackbar in dB
1 -20 // Right Vol Line Trackbar in dB
2 -20 // Left Vol HP Trackbar in dB
3 -20 // Right Vol HP Trackbar in dB
4 00 // Analog Register setting in decimal
5 00 // Digital Register setting in decimal
6 00 // Power Down Register setting in decimal
7 64 // Format Register setting in decimal
8 00 // Sampling Rate Register setting in decimal
9 01 // Interface Activate Register setting in decimal

```

```

ModeThree.txt - Notepad
File Edit Search Help
0 -20 // Left Vol Line Trackbar in dB
1 -20 // Right Vol Line Trackbar in dB
2 -20 // Left Vol HP Trackbar in dB
3 -20 // Right Vol HP Trackbar in dB
4 18 // Analog Register setting in decimal
5 00 // Digital Register setting in decimal
6 00 // Power Down Register setting in decimal
7 64 // Format Register setting in decimal
8 00 // Sampling Rate Register setting in decimal
9 01 // Interface Activate Register setting in decimal

```

#### 4.6.2 L Vol (Line Input) Register

Address: 0000000

D4–D0 set the left line input volume. D8 sets simultaneous right/left volume/mute.

D7 sets the left input mute.

Setting the bit values in this register is functionally equivalent to operating the Line Input Volume Left controls on the main panel (see Section 4.4.5).

#### 4.6.3 R Vol (Line Input) Register

Address: 0000001

D4–D0 set the right line input volume. D8 sets simultaneous right/left volume/mute.

D7 sets the right input mute.

Setting the bit values in this register is functionally equivalent to operating the Line Input Volume Right controls on the main panel (see Section 4.4.5).

#### 4.6.4 L Vol (HeadPhone) Register

Address: 0000010

D6–D0 set the volume control for the left headphone. D7 enables the zero-cross detect. D8 sets simultaneous right/left volume/mute.

Setting the bit values in this register is functionally equivalent to operating the HeadPhone Volume Left controls on the main panel (see Section 4.4.6).

#### 4.6.5 R Vol (HeadPhone) Register

Address: 0000011

D6–D0 set the volume control for the right headphone. D7 enables the zero-cross detect. D8 sets simultaneous right/left volume/mute.

Setting the bit values in this register is functionally equivalent to operating the HeadPhone Volume Right controls on the main panel (see Section 4.4.6).

#### 4.6.6 OK, Apply, and Cancel Buttons

The *Cancel* button undoes any changes that have been made in register bit values, so the register panel matches the current state of the EVM registers. The *Apply* button sends the current bit values shown on the register panel to the EVM and stores them in the EVM registers. The *OK* button performs the same function as the *Apply* button and simultaneously closes the register panel.

#### 4.6.7 Audio (Analog) Register

Address: 0000100

D7–D6 set the sidetone attenuation (00 = –6 dB, 01 = –9 dB, 10 = –12 dB, 11 = –15 dB). D5 sets sidetone enable (0 = disabled, 1 = enabled). D4 sets the DAC select (0 = DAC off, 1 = DAC selected). D3 sets the bypass (0 = disabled, 1 = enabled). D2 sets the input for the ADC (0 = line, 1 = microphone). D1 sets the microphone mute (0 = normal, 1 = muted). D0 sets the microphone boost (0 = 0 db, 1 = 20 dB).

Clicking the *Analog Control* button opens an *Analog Control* panel (see Figure 4–6) that allows setting all the analog audio parameters without reference to their bit values. The *Analog Control* button in the analog audio register box is functionally identical to the *Analog Control* button on the main panel (see Section 4.4.15).

The *Cancel* button undoes any changes that have been made in register bit values, so the register panel matches the current state of the EVM registers. The *Apply* button sends the current bit values shown on the *Analog Control* panel to the *Audio (Analog)* register section of the register panel. The *OK* button performs the same function as the *Apply* button and simultaneously closes the register panel.

Figure 4–6. *Analog Control*

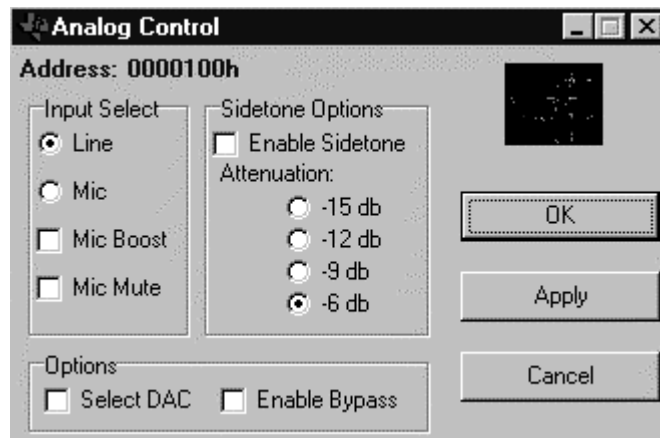

#### 4.6.8 Audio (Digital) Register

Address: 0000101

D3 sets the DAC soft mute (0 = disabled, 1 = enabled). D2–D1 set the de-emphasis control (00 = disabled, 01 = 32 kHz, 10 = 44.1 kHz, 11 = 48 kHz). D0 sets the ADC high-pass filter (0 = disabled, 1 = enabled).

Clicking the *Digital Control* button opens a *Digital Control* panel (see Figure 4–7) that allows setting all the digital audio parameters without reference to their bit values. The *Digital Control* button in the digital audio register box is functionally identical to the *Digital Control* button on the main panel (see Section 4.4.14).

The *Cancel* button undoes any changes that have been made in register bit values, so the register panel matches the current state of the EVM registers.

The *Apply* button sends the current bit values shown on the *Analog Control* panel to the *Audio (Digital)* register section of the register panel. The *OK* button performs the same function as the *Apply* button and simultaneously closes the register panel.

Figure 4–7. Digital Control

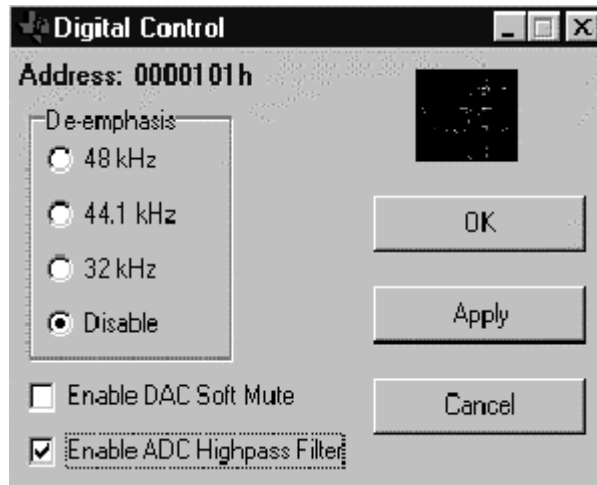

#### 4.6.9 Power Down Register

Address: 0000110

D7 sets the device power. D6 sets CLK. D5 sets the oscillator. D4 sets the outputs. D3 sets the DAC. D2 sets the ADC. D1 sets the microphone input. D0 sets the line input.

Clicking the *Send Data* button sends only the power down data without clicking the *Apply* button.

#### 4.6.10 Audio (Format) Register

Address: 0000111

D6 sets master/slave (0 = slave, 1 = master). D5 sets the DAC left/right swap (0 = disabled, 1 = enabled). D4 sets the DAC left/right phase (0 = right channel on, LRCIN high, 1 = LRCIN low). In DSP mode (0 = MSB is available on the first BCLK rising edge after an LRCIN rising edge, 1 = MSB is available on the second BCLK rising edge after an LRCIN rising edge). D3–D2 set the input word length (00 = 16b, 01 = 20b, 10 = 24b, 11 = 32b). D1–D0 set the data format (11 = DSP; 10 = I<sup>2</sup>S; 01 = MSB first, left aligned; 00 = MSB first, right aligned).

Clicking the *Format Control* button opens a *Format Control* panel (see Figure 4–8) that allows setting all the audio format parameters without reference to their bit values. The *Format Control* button in the audio format register box is functionally identical to the *Format Control* button on the main panel (see Section 4.4.16).

The *Cancel* button undoes any changes that have been made in register bit values, so the register panel matches the current state of the EVM registers.



The *Apply* button sends the current bit values shown on the *Analog Control* panel to the *Audio (Format)* register section of the register panel. The *OK* button performs the same function as the *Apply* button and simultaneously closes the register panel.

Figure 4–8. Format Control

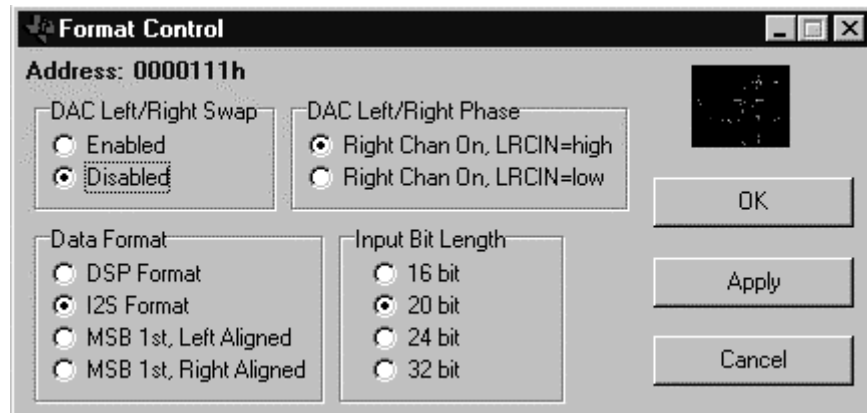

#### 4.6.11 Sampling Rate Register

Address: 0001000

D7 sets the clock output divider (0 = MCLK, 1 = MCLK/2), D6 sets clock input divider (0 = MCLK, 1 = MCLK/2). D5–D2 set the SR3–SR0 bits. D1 sets the base oversampling rate (In USB mode, 0 =  $250 f_S$  and 1 =  $272 f_S$ ; in normal mode, 0 =  $256 f_S$  and 1 =  $384 f_S$ ). D0 sets the USB/normal mode (0 = normal, 1 = USB).

Clicking the *Clock Select* button opens a *Normal Clock Setup* panel (see Figure 4–9) that allows the selection of master clock speed and ADC and DAC sampling rates. There are also two check boxes for setting the clock input divider and clock output divider on or off. Because the correspondence between clock settings and register bit values is not intuitively obvious, it may be easier to input the desired clock frequency and sampling rates in the *Normal Clock Setup* panel and observe the bit settings that appear in the registers panel. The *Clock Select* button in the sampling rate register box is functionally identical to the *Clock Select* button on the main panel (see Section 4.4.18).

The *Cancel* button undoes any changes that have been made in register bit values, so the register panel matches the current state of the EVM registers. The *Apply* button sends the current bit values shown on the *Analog Control* panel to the *Sampling Rate* register section of the register panel. The *OK* button performs the same function as the *Apply* button and simultaneously closes the register panel.

Figure 4–9. Clock Setup

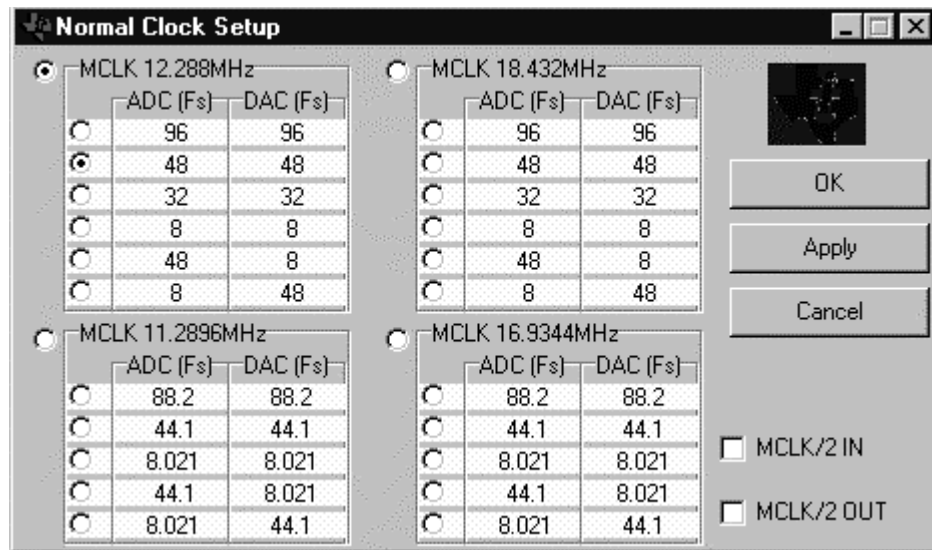

#### 4.6.12 Interface Activate Register

Address: 0001001

D0 activates the digital interface (0 = inactive, 1 = active).

Clicking the *Send Data* button sends only the interface activation data without clicking the *Apply* button.

# I<sup>2</sup>C Error Messages

The error messages are only visible during error conditions. The error messages are located just above the RESET button in the main panel. The first message to appear will be above the second message. For example, if an ACK error occurs first then it is displayed first and it is only displayed once. The software continues to send data to the device even with ACK and WAIT errors. But it no longer looks for ACK or WAIT errors, therefore the response from the device can be undetermined.

No.	Error Message	Cause
1	ACK error	The AIC23/DAC23 is not sending an acknowledge command back to the host processor. This is referred to as an ACK in I <sup>2</sup> C terminology. The software does not terminate the transactions.
		Pin 1 (SDA) or pin 14 (SCL) on the parallel cable is not allowing the I <sup>2</sup> C commands to reach the EVM.
		Pin 15 on the parallel cable is not allowing the ACK command to return back to the host.
		The LPT port is not connected and configured for EPP or bidirectional mode (PS-2 in some cases).
		The actual LPT port connected does not match the LPT port selected in the *.dat file.
		LPT1 is the default for the LPT port, if it is not explicitly defined in the file. The hexadecimal addresses for the ports defined in the software are LPT1 = 0x378, LPT2 = 0x278, and LPT3 = 0x3BC.
2	WAIT error	The AIC23/DAC23 is holding the SCL line low and not releasing it for the host processor. This is referred to as waiting the bus in I <sup>2</sup> C terminology. The AIC23/DAC23 software does not terminate the transactions.
		Pin 1 (SDA) or pin 14 (SCL) on the parallel cable is not allowing the I <sup>2</sup> C commands to reach the EVM.
		Pin 10 on the parallel cable is not allowing the host to read a high SCL. Therefore a WAIT is assumed.



# Kit Contents

---

---

---

---

This chapter contains a list of the contents of the TLV320AIC23 EVM2 kit and a bill of materials for the TLV320AIC23 EVM2 board.

<b>Topic</b>	<b>Page</b>
<b>6.1 TLV320AIC23 EVM2 Kit Contents .....</b>	<b>6-2</b>
<b>6.2 Bill of Materials .....</b>	<b>6-3</b>

## 6.1 TLV320AIC23 EVM2 Kit Contents

TLV320AIC23 EVM2 is shipped with the following:

- 1) TLV320AIC23 EVM2 evaluation module
- 2) DAREF106R2 parallel port interface board
- 3) TLV320AIC23 EVM2 CD. The CD contains the following:
  - a) TLV320AIC23 data manual
  - b) TLV320AIC23 EVM2 user's guide
  - c) Schematic
  - d) Bill of materials
  - e) PCB
  - f) Gerbers
  - g) GUI software
- 4) Parallel port cable, 8-pin

## 6.2 Bill of Materials

Description	Qty.	Part Number	Mfr.	Ref. Des.
AND Gate, Single 2-Input Positive	1	SN74AHC1G08DBVR	Texas Instruments	AND2
AND Gate, Single 2-Input Positive	1	SN74AHCT1G08DBVR	Texas Instruments	AND1
Buffer/Driver, Dual w/3-State Outputs	3	SN74LVC2G241DCTR	Texas Instruments	U3, U4, U5
CAP 27PFD 50V CERM 0603 NPO	2	ECU-V1H270JCV	Panasonic	C13, C14
CAP 47PFD 50V CERM 0603 NPO	3	ECJ-1VC1H470J	Panasonic	C3, C5, C8
CAP .01UFD 16V CERM 0603 X7R	2	ECJ-1VB1C104K	Panasonic	C15, C25
CAP .01UFD 25V CERM 0603 X7R	11	ECJ-1VB1E103K	Panasonic	C21, C23, C29, C31, C33, C35, C36, C38, C40, C42, C43
CAP 0.1UFD 50V CERM 0805 X7R	1	ECJ-2YB1H104K	Panasonic	C12
CAP 1.0UFD 16V CERM 0805 X7R	14	ECJ-2VF1C105Z	Panasonic	C1, C2, C4, C6, C7, C20, C22, C28, C30, C32, C34, C37, C39, C41
CAP 10UFD 6.3V TANT ELEC SMD TEA	1	ECS-T0JY106R	Panasonic	C11
CAP 10UFD 16V ALUM ELEC SM-VSA	4	ECE-V1CS100SR	Panasonic	C16, C17, C18, C19
CAP 100UFD 10V RAD ALUM ELEC HFQ	3	ECA-1AFQ101	Panasonic	C9, C10, C24
Codec, 16-Bit Stereo Audio	1	TLV320AIC23PW	Texas Instruments	U1
Connector, 20 Pin Box Header	1	2520-6002UB	3M	J7
Ferrite Bead, 11 Ohms 1.5A SM0805	2	MI0805K110R-00	Steward	FB5, FB7
Ferrite Bead, 31 Ohms 1.5A SM1206	3	MI1206K310R-00	Steward	FB1, FB3, FB4
Header, 2 Pin Male, Straight, Gold	1	PZC02SAAN	Sullins	JP2
Header, 3 Pin Male, Straight, Gold	1	PZC03SAAN	Sullins	JP1
Jack, MINI-Mono, PCB-RA, 3,5 mm	1	MJ-3502N	CUI Stack	J3
Jack, MINI-Stereo, PCB-RA, 3,5 mm	3	SJ-3535N	CUI Stack	J4, J1, J2
Jack, PWR-MINI, 2.5mm SMD+TH	1	RASH712	Switchcraft	PJ1
Jack, RCA, PCB-Right Angle, Black	4	16PJ097	DGS Pro Audio	J1L, J1R, J2L, J2R
Jack, SMA PCB Gold	2	901-144-8-RFX	Amphenol	J8, J6
Jack, PS2-Female, 8 Position, PCB-Right Angle	1	MD-80S	CUI Stack	J5
LED, Red SM1206	1	CMD15-21VRD/TR8	Chicago Miniature	LED1
MUX, Single 2to1 W/Common Strobe	1	SN74LVC2G157DCTR	Texas Instruments	U2
Rectifier, Silicon 1A 400V	1	DL400413	Diodes, Inc.	CR2
Rectifier, SW 0.15A 75V SMT MiniMELF	1	DL4148	Micro Commercial Co.	CR1
RES 0.0 OHM 1/10W 5% SMD 0805	1	ERJ-GEY0R00V	Panasonic	R7

Bill of Materials

Description	Qty.	Part Number	Mfr.	Ref. Des.
RES 3.3 OHM 1/8W 5% SMD 1206	9	ERJ-8RQJ3R3V	Panasonic	R11, R12, R13, R14, R15, R16, R19, R27, R29
RES 10.0 OHM 1/8W 1% SMD 1206	1	ERJ-8ENF10R0V	Panasonic	R17
RES 10 OHM 1W 5% SMD 2512	1	ERJ-1WY100U	Panasonic	R18
RES 49.9 OHM 1/16W 1% SMD 0603	1	ERJ-3EKF49R9V	Panasonic	R31
RES 49.9 OHM 1/8W 1% SMD 1206	1	ERJ-8ENF49R9V	Panasonic	R33
RES 499 OHM 1/16W 1% SMD 0603	1	ERJ-3EKF4990V	Panasonic	R26
RES 2.2K OHM 1/10W 5% SMD 0805	1	ERJ-6GEYJ222V	Panasonic	R8
RES 4.99K OHM 1/16W 1% SMD 0603	6	ERJ-3EKF4991V	Panasonic	R1, R2, R4, R5, R30, R32
RES 100K OHM 1/16W 1% SMD 0603	5	ERJ-3EKF1003V	Panasonic	R3, R6, R9, R10, R22
RES 169K OHM 1/16W 1% SMD 0603	2	ERJ-3EKF1693V	Panasonic	R24, R25
RES 301K OHM 1/16W 1% SMD 0603	2	ERJ-3EKF3013V	Panasonic	R21, R23
Voltage regulator, LDO-Adj., 150mA	2	TPS76301DBVR	Texas Instruments	VR1, VR2



# Circuit Card and Schematic

---

---

---

---

This appendix contains the following items for the TLV320AIC23 EVM2, in the order listed:

- 1) Top silkscreen
- 2) Copper layer 1
- 3) Copper layer 2
- 4) Schematic diagram

TEXAS INSTRUMENTS, INC. 2001  
DAV-AUDIO GROUP  
TLV320AIC23EVM2 Evaluation Module  
HIDDEN TEXT FOR TOP SILKSCREEN: TLV320AIC23EVM2.SS1

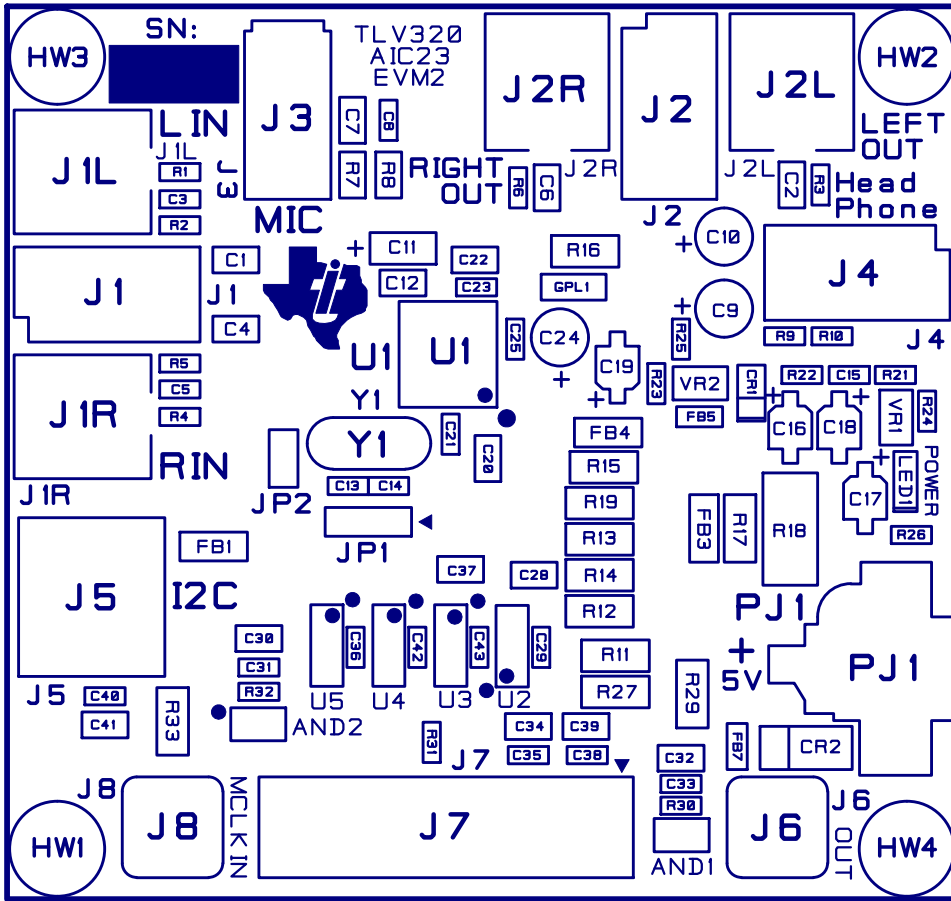

TEXAS INSTRUMENTS, INC. 2001  
DAV-AUDIO GROUP  
TLV320AIC23EVM2 Evaluation Module  
TOP SILKSCREEN: TLV320AIC23EVM2.SS1

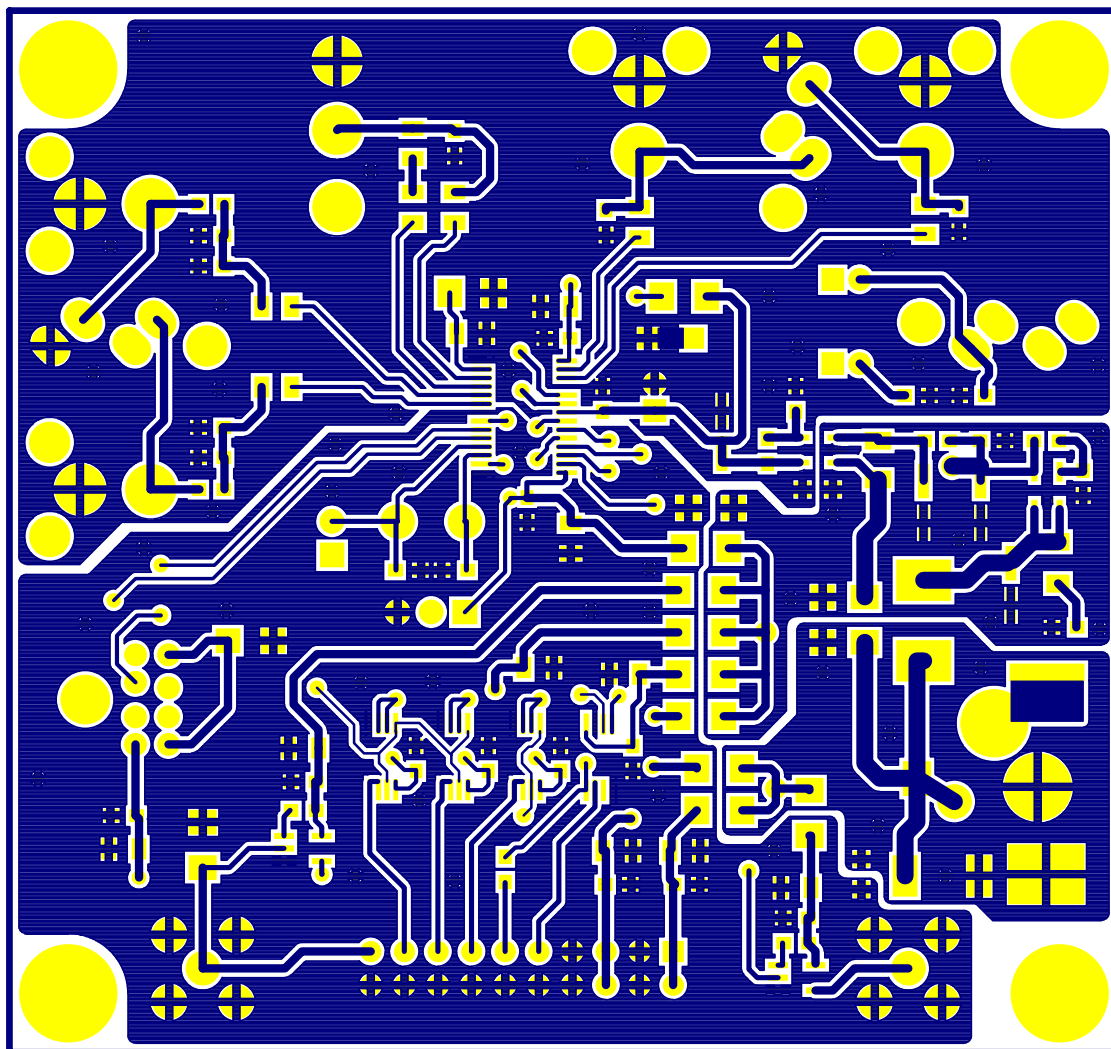

TEXAS INSTRUMENTS, INC. 2001  
DAV-AUDIO GROUP  
TLV320AIC23EVM2 Evaluation Module  
COPPER LAYER 1: TLV320AIC23EVM2.CL1

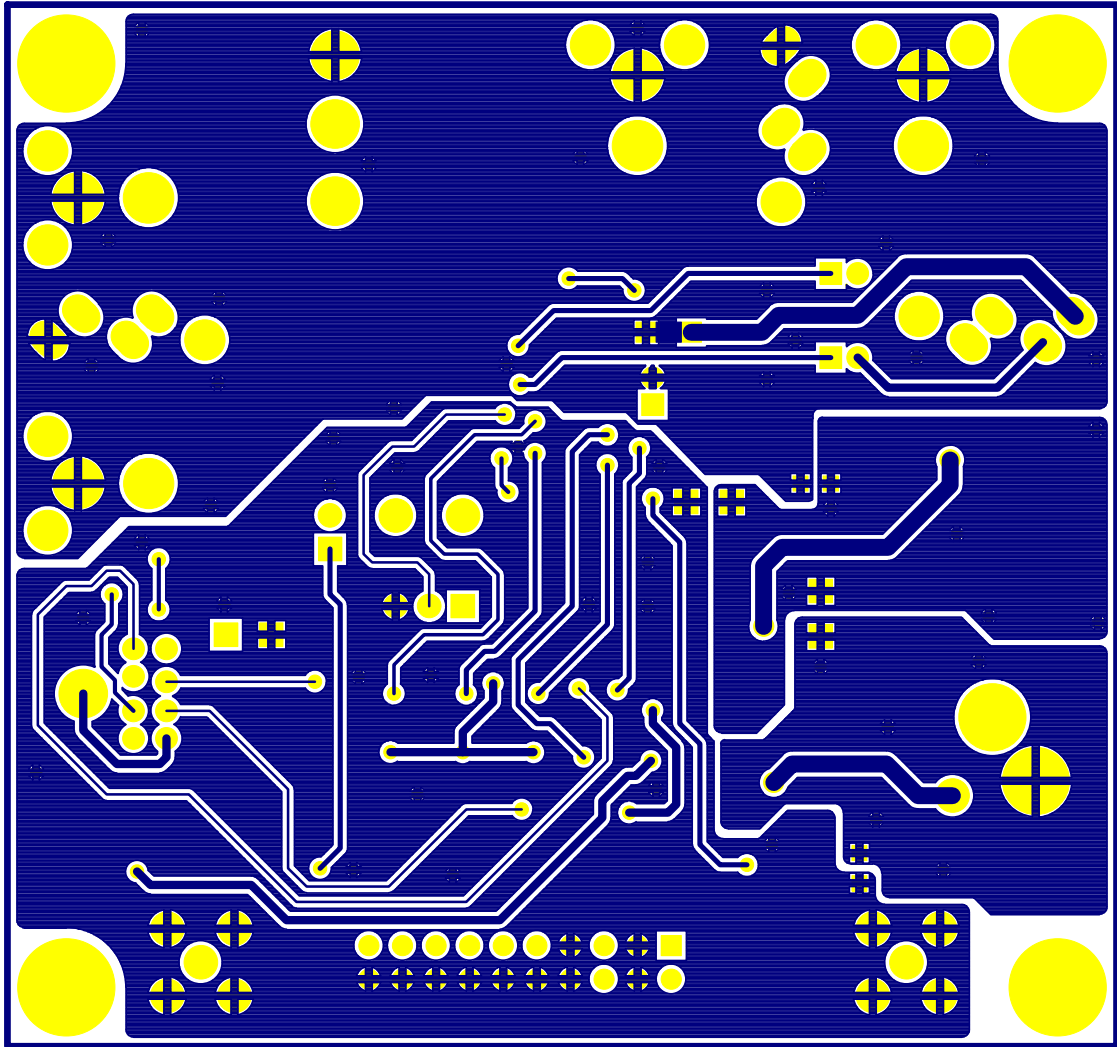

TEXAS INSTRUMENTS, INC. 2001  
DAV-AUDIO GROUP  
TLV320AIC23EVM2 Evaluation Module  
COPPER LAYER 2: TLV320AIC23EVM2.CL2

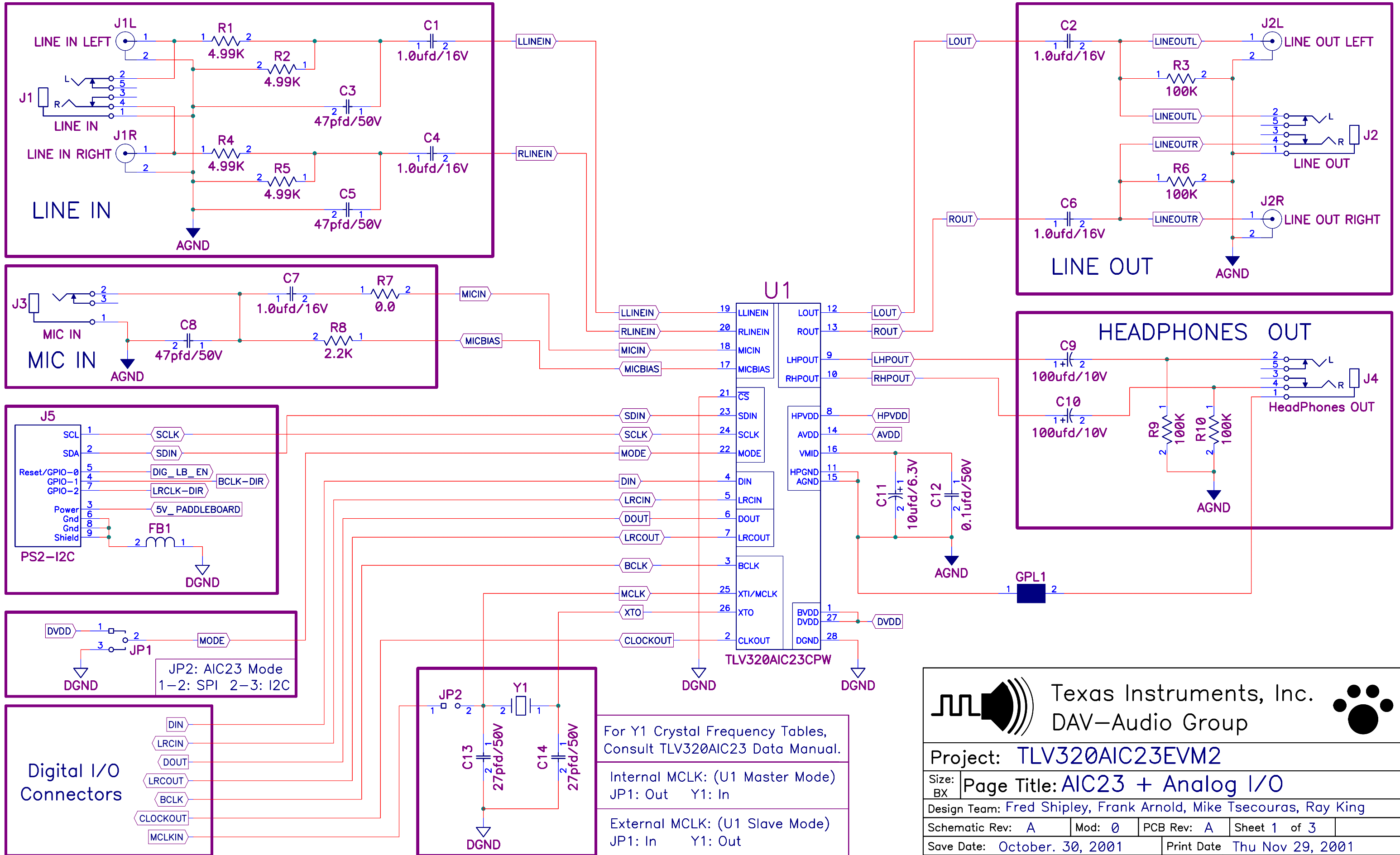

For Y1 Crystal Frequency Tables, Consult TLV320AIC23 Data Manual.

Internal MCLK: (U1 Master Mode)  
JP1: Out Y1: In

External MCLK: (U1 Slave Mode)  
JP1: In Y1: Out

Texas Instruments, Inc.  
DAV-Audio Group

Project: TLV320AIC23EVM2

Size: BX Page Title: AIC23 + Analog I/O

Design Team: Fred Shipley, Frank Arnold, Mike Tsecouras, Ray King

Schematic Rev: A Mod: 0 PCB Rev: A Sheet 1 of 3

Save Date: October. 30, 2001 Print Date: Thu Nov 29, 2001

Filename: TLV320AIC23EVM2.SCH Drawn By: LDN

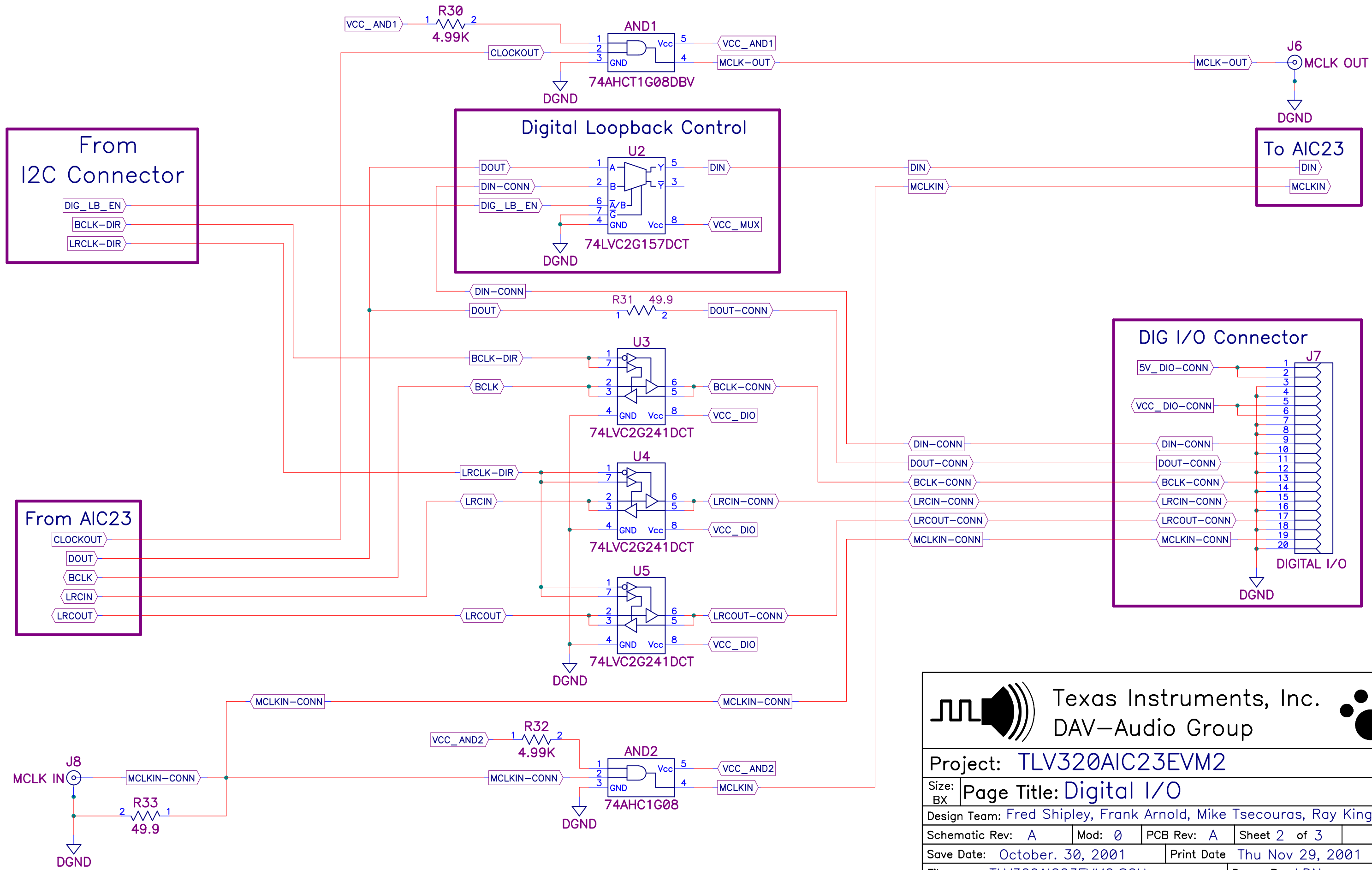

Project: TLV320AIC23EVM2				
Size: BX	Page Title: Digital I/O			
Design Team: Fred Shipley, Frank Arnold, Mike Tsecouras, Ray King				
Schematic Rev: A	Mod: 0	PCB Rev: A	Sheet 2 of 3	
Save Date: October. 30, 2001		Print Date: Thu Nov 29, 2001		
Filename: TLV320AIC23EVM2.SCH			Drawn By: LDN	

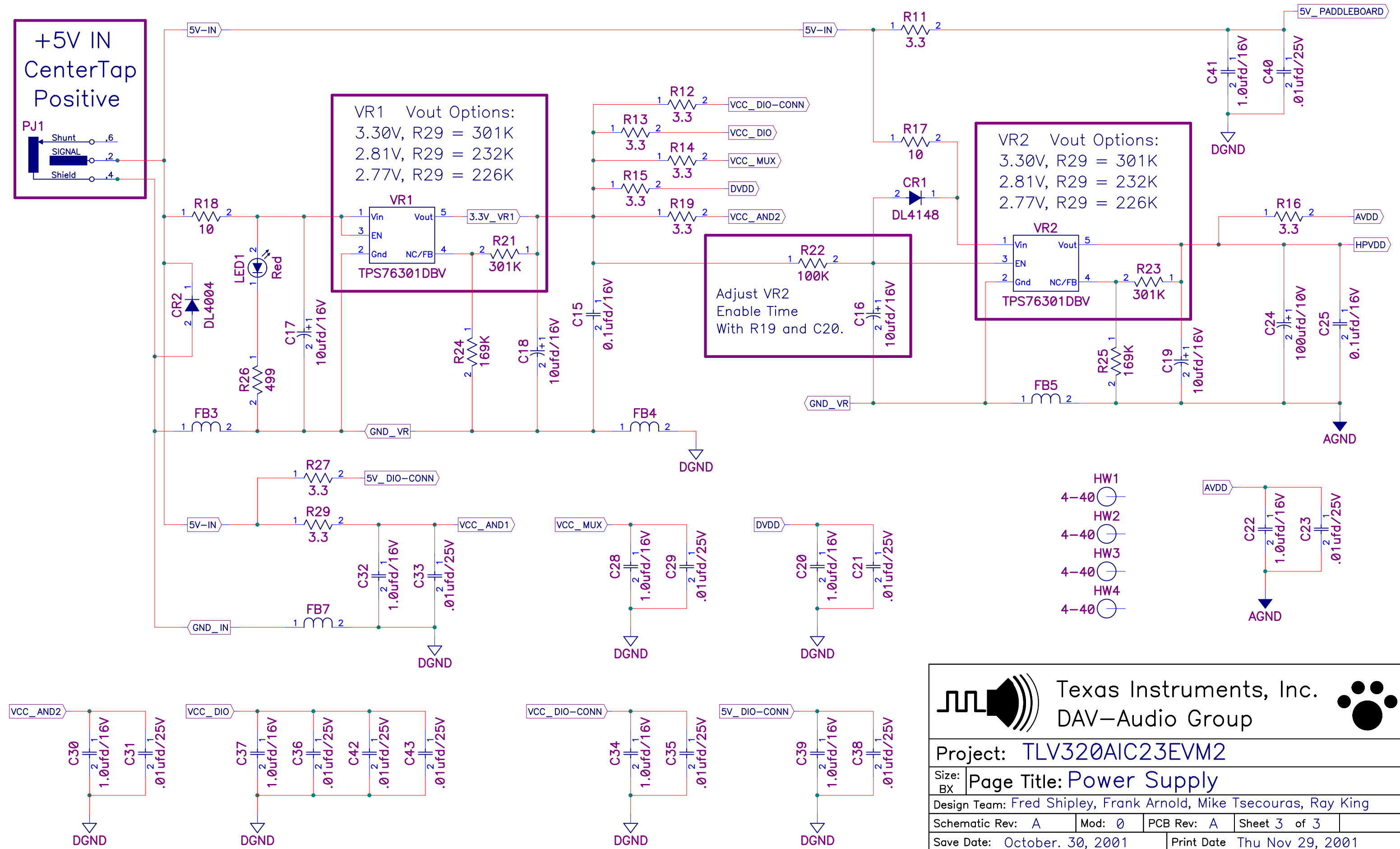
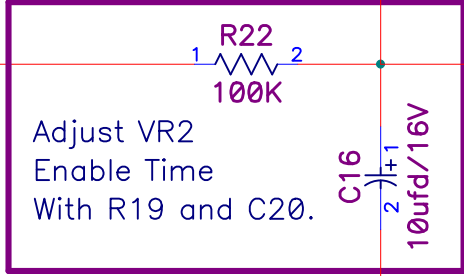
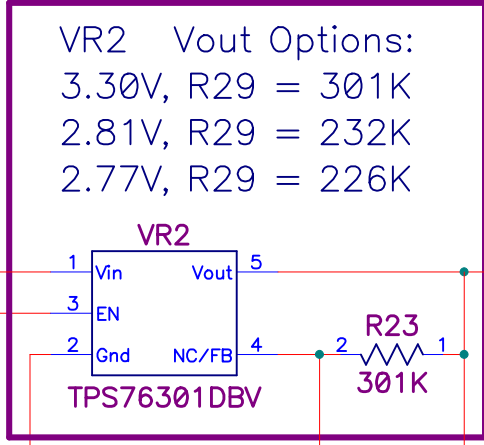
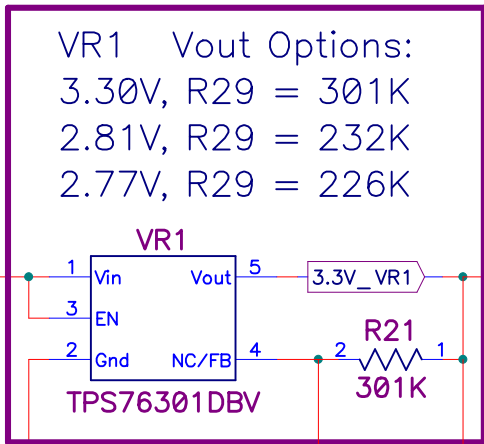
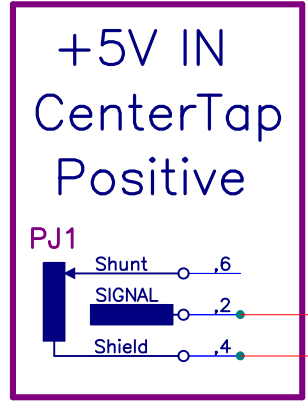

- HW1 4-40
- HW2 4-40
- HW3 4-40
- HW4 4-40

Texas Instruments, Inc.  
 DAV-Audio Group

Project: TLV320AIC23EVM2

Size: BX	Page Title: Power Supply		
Design Team: Fred Shipley, Frank Arnold, Mike Tsecouras, Ray King			
Schematic Rev: A	Mod: 0	PCB Rev: A	Sheet 3 of 3
Save Date: October. 30, 2001		Print Date: Thu Nov 29, 2001	
Filename: TLV320AIC23EVM2.SCH			Drawn By: LDN