

# Using the TPS23851EVM-001

## User's Guide



Literature Number: SLUU492  
February 2011

## ***Using the TPS23851EVM-001***

---

---

---

This user guide describes setup and use of the TPS23851EVM-001.

### **1 Introduction**

It includes connection and wiring descriptions, PC installation of the user interface, schematics and layout information and a detailed section describing how to use the GUI.

### **2 Equipment Supplied**

- HPA677 Backplane Board
- HPA676 PSE Controller Board

### **3 Equipment Required**

- Computer
- Laptop Computer Power Supply or 20-V<sub>DC</sub> to 60-V<sub>DC</sub> Power Supply
- USB to Mini-USB Cable
- Valid POE Load
- National Instruments Website Download
- Texas Instrument's GUI for the TPS23851 ([TPS23851 GUI Software](#))

## 4 Hardware Connections

### 4.1 PCB Assemblies

The HPA677 is a backplane board. The HPA677 has two power supplies, the power-over-Ethernet ports and the USB to I<sup>2</sup>C interface to support the HPA676. The HPA676 connects to the backplane board. The HPA676 has the TPS23851 PSE controller and a power supply for the TPS23851. It controls port connection to a valid PD.

Plug the HPA676 PCB assembly into the HPA677 backplane by aligning the three 10-pin connectors on each board. See Board alignment photo, [Figure 1](#).



**Figure 1. Board Alignment**

### 4.2 Power Supplies

Use either a laptop computer power supply or if not available, a lab power supply. No adjustment is necessary with the laptop supply. Just plug the supply into J17.

With the lab power supply, if used, you must disconnect the output, turn on the power supply and adjust the output voltage to 24 V +/-2 V. Adjust the supply current limit to 3 A. Connect the power supply output to J9-1 and the supply GND to J9-2.

Connector J16 can be used to by-pass the 24-V to 54-V converter. This may be done if there is need to vary 54 V when injecting a voltage into J16, remove any other input power at either J17 or at J9 when using J16.

### 4.3 USB Cable

Turn on the power supply first and then plug the USB connector. Green LED, D1 should turn on. [Figure 2](#) shows the interconnect boards with power supply, USB, and POE load attachment.

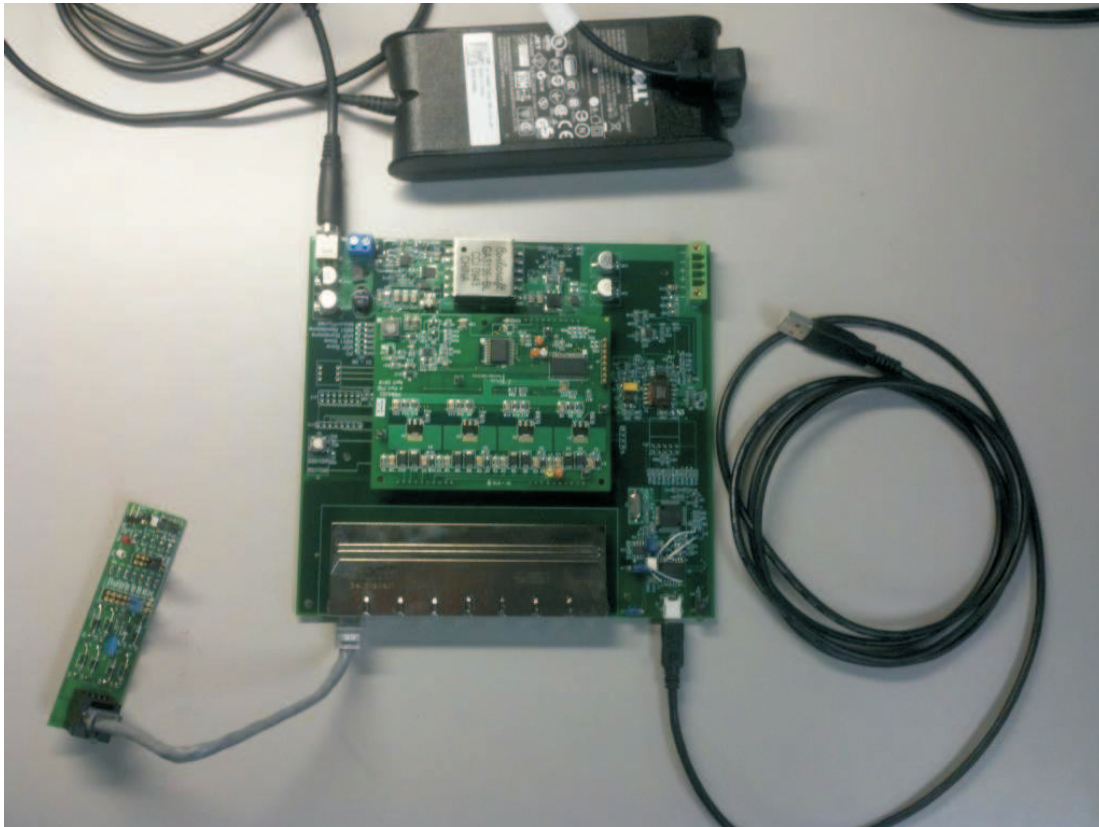

**Figure 2. Components and Interconnects**

## 5 GUI Setup

1. Create a folder for the GUI and the National Instrument's download.
2. Go to National Instruments website and download and install the **LabView Runtime Engine** to the new folder. Follow directions on screen. The download is free but you may be asked for a registration. Use this link to get the runtime engine: <http://joule.ni.com/nidu/cds/view/p/id/1101/lang/en>. Download **LVRTE86std.exe** and install.
3. Copy the attached file, [TPS23851 GUI Software](#), to the new folder on the PC and unzip. Go to folder TPS23851GUI and Double-click TPS23851.exe.
4. The GUI should start. Power the EVM and plug in a USB cable from computer to EVM. The green LED at D1 will turn on.

## 6 GUI Getting Started

The I<sup>2</sup>C device address is set in the hardware for address 20h. The GUI also defaults to this address. If a different address is needed, go to the GUI's right half of the screen's **Setup Tab** and enter the new I<sup>2</sup>C address. See [Figure 3](#).

Also in the **Setup Tab** screen, the 400-kHz I<sup>2</sup>C (default) is selected.

Leave the termination set to the default setting, open.

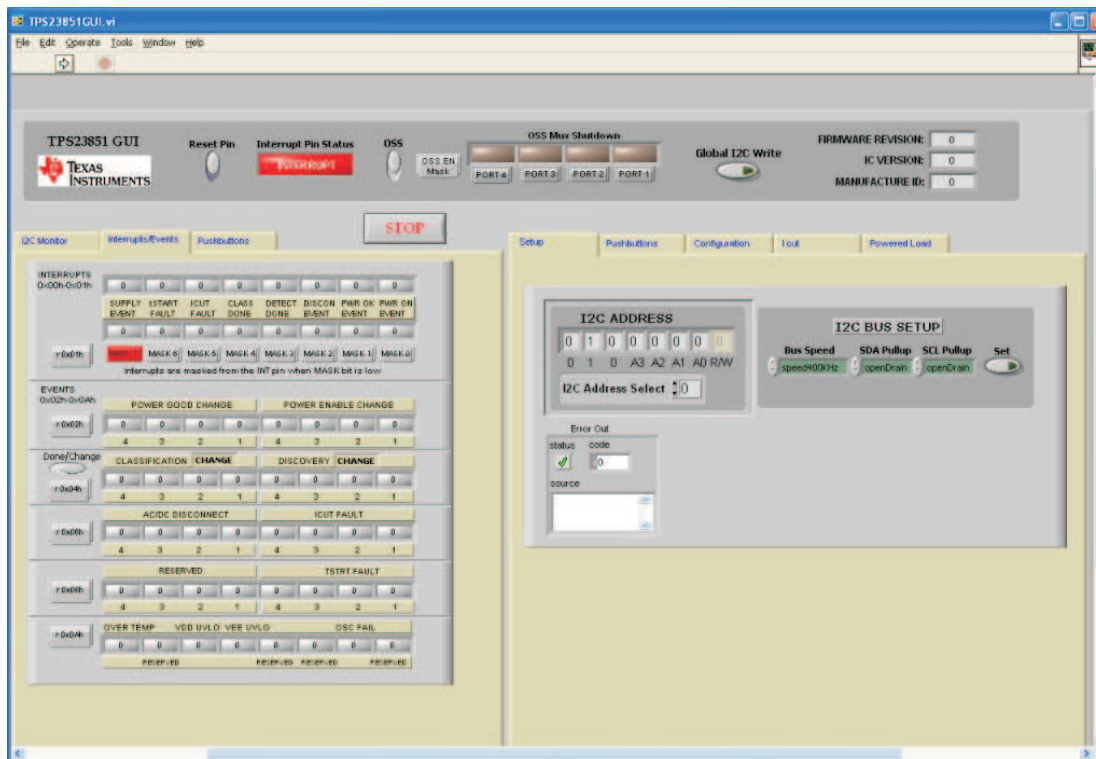

Figure 3. Interrupt/Events and Setup Tabs

Select the **Configuration Tab** (reference [Figure 4](#)). At the far right in the **Configuration Screen**, the selections are global which means they apply to all 4 ports. At the pull down that says **Manual**, select **AUTO**, and select the **r0x12h Button** just to the left of **AUTO**. The four columns to the left get set to **AUTO**.

To the left of **GLOBAL** on this same screen the window allows individual set up for each output port. Those selections are then applied using the **r0x12h Button** to the left of the four-port mode entries.

Detection and classification are initiated within the parameters of the mode already selected by either global or single port selection in the same way the mode was set. Then click the **r0x14h Button** to activate. Classification and detection can be set or cleared before initiation with the green **CLEN** and **DEN Rectangular Buttons**. The green LEDs turn on for good status indication.

Plug in a valid PD load to any of the four left-side ports and the load will be powered. The connectors are ordered Port 4 thru Port 1 where Port 4 is the leftmost connector. The right-side 4 connectors are not operational but are included for expansion. Left or right is determined by facing the port connectors plug input side.

After an operator action in the GUI, the resultant event may be checked in other GUI windows tabs such as **Events or Interrupts**. **Interrupt/Event Tabs** are shown in the left half of Figure 3. Follow the tabs to get to the proper window to check results.

**RUN and STOP** are in the upper left corner of the GUI screen. The GUI is running when the arrow is black filled.

Reset is not active from the GUI Button. Reset can be done through the on-board push button switch. Auto is grounded so all ports reset or power-up OFF.



Figure 4. GUI Buttons

## 7 HPA676 Test Points

**Table 1. HPA676 Test Points**

TEST POINT	SIGNAL NAME
TP1	PORT1_N
TP2	PORT1_P
TP3	GND
TP4	PSE_SDAI
TP5	GND
TP6	N48V_POE
TP7	PSE_SCL
TP8	PSE_SDAO
TP9	SDA
TP10	GND1
TP11	GND
TP12	GND
TP13	V3_3
TP14	N48V_POE
TP15	GND
TP16	OUT_P1
TP17	GATE_1
TP18	SEN_P1

## 8 HPA676 Test Point Connector

**Table 2. HPA676 Test Point Connector**

J4	SIGNAL NAME
1	GND
2	TSTA
3	Shutdown4
4	Shutdown2
5	Shutdown3
6	Shutdown1
7	INT
8	V3_3

## 9 Switches

- HPA676 - None
- HPA677 – S2 is a momentary **RESET** push button switch. This causes a reset to the TPS23851.

## 10 LEDs

- HPA677 - Green LED D1 indicates USB attach

## 11 Jumpers

- HPA676 - None
- HPA677 – See [Table 3](#)

**Table 3. Jumper Function**

JUMPER	FUNCTION	USER NOTES
J2	Hi / Lo speed USB input	J2 1-2, HI and J2 2-3, Lo
J4	Hi / Lo speed USB output	J4 2-3, HI and J21-2, Lo
J5	Manufacturing use	J5 must be ON
J10	Enable USB interface	J10 must be ON
J14	Manufacturing use	J14 must be OFF
J18	Manufacturing use	Must be position J18 1-2

## 12 HPA677 Test Points

**Table 4. HPA677 Test Points**

TEST POINT	SIGNAL NAME
TP1	54-V, output-side feedback
TP2	18-V to 60-V input (positive)
TP3	18-V to 60-V input (negative)
TP4	54-V, input-side feedback
TP5	54-V output
TP6	54-V negative / GND
TP7	<b>RESET</b>
TP8	Computer GND
TP9	GND
TP10	SCL
TP11	3.3-V out
TP12	3.3-V, input-side feedback
TP13	SDA



13 HPA676 Schematics

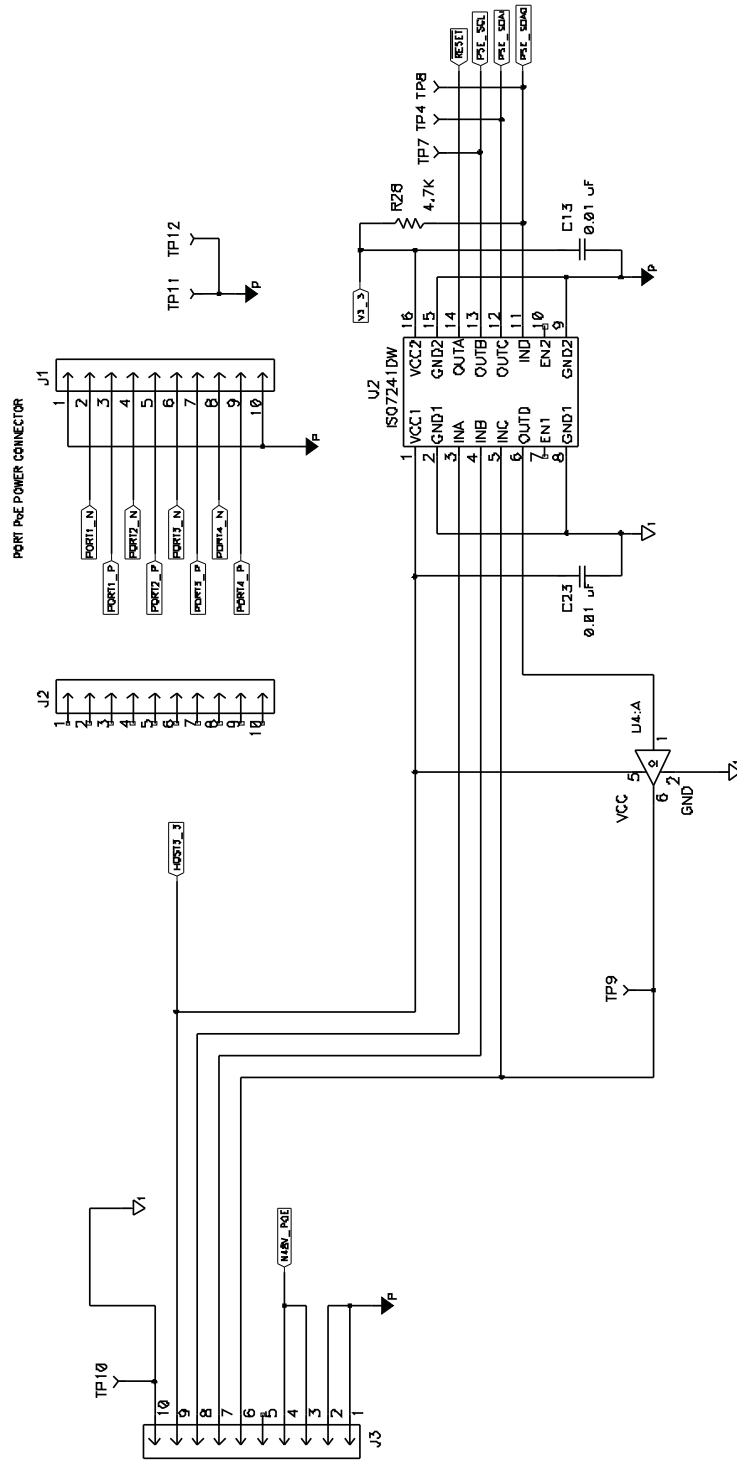

Figure 5. HPA676 Schematic 1

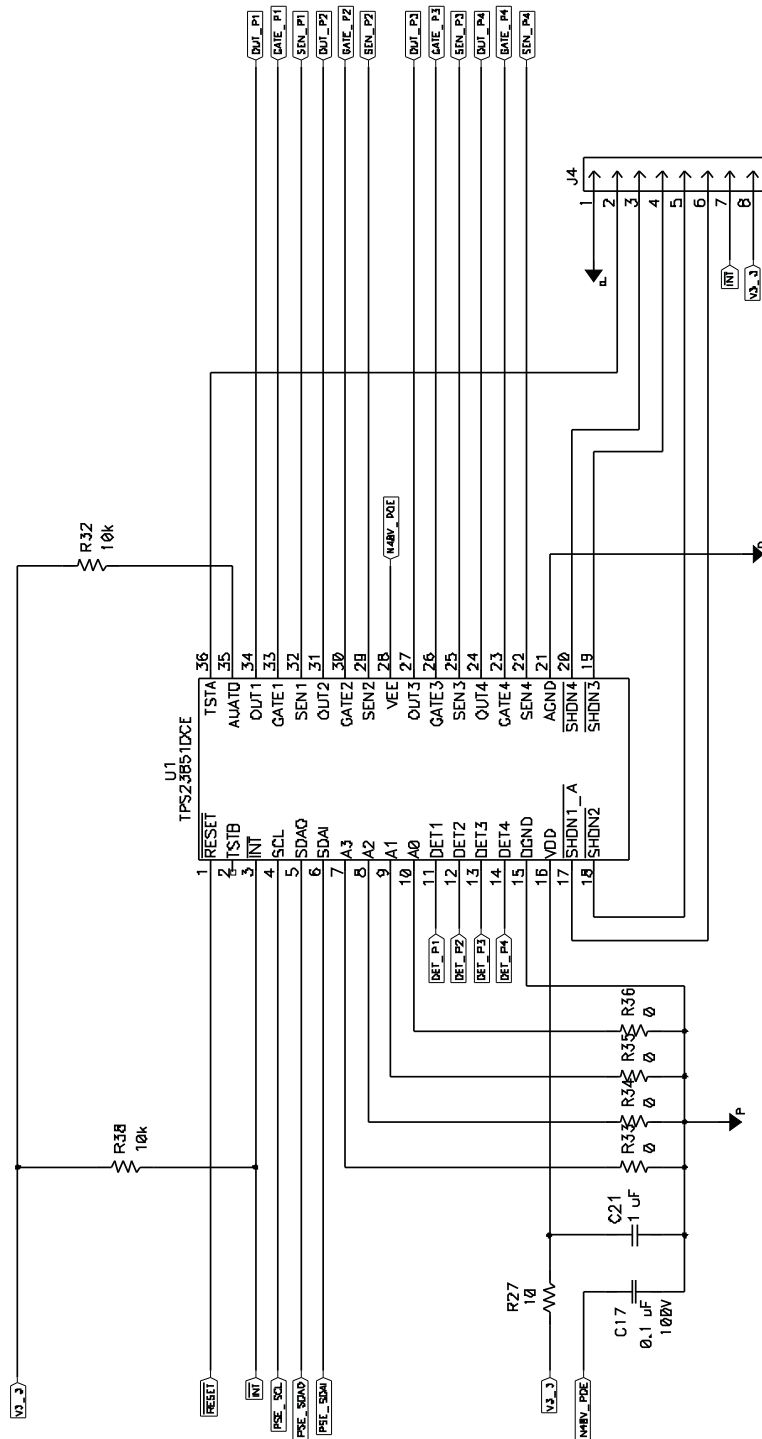

Figure 6. HPA676 Schematic 2

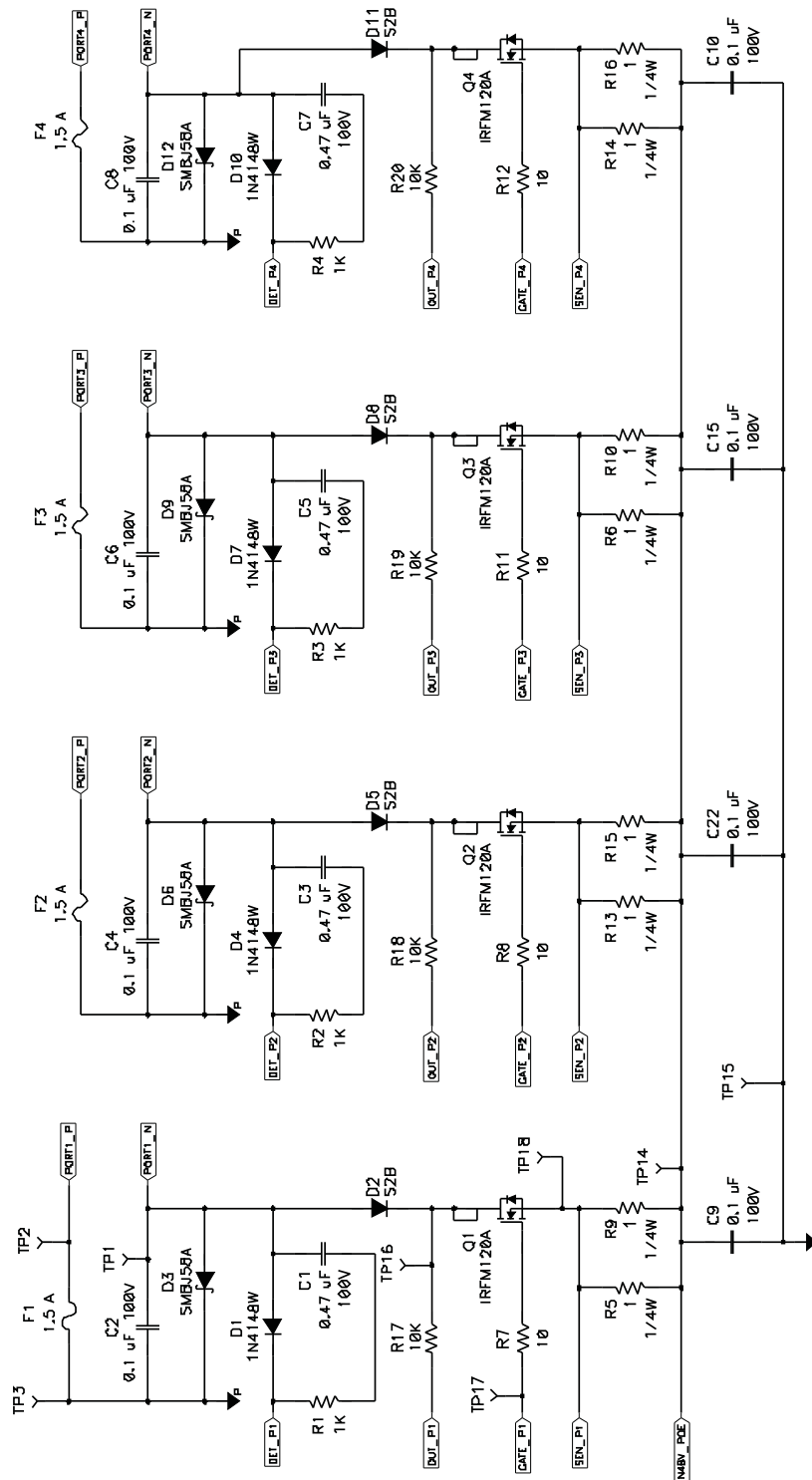

Figure 7. HPA676 Schematic 3

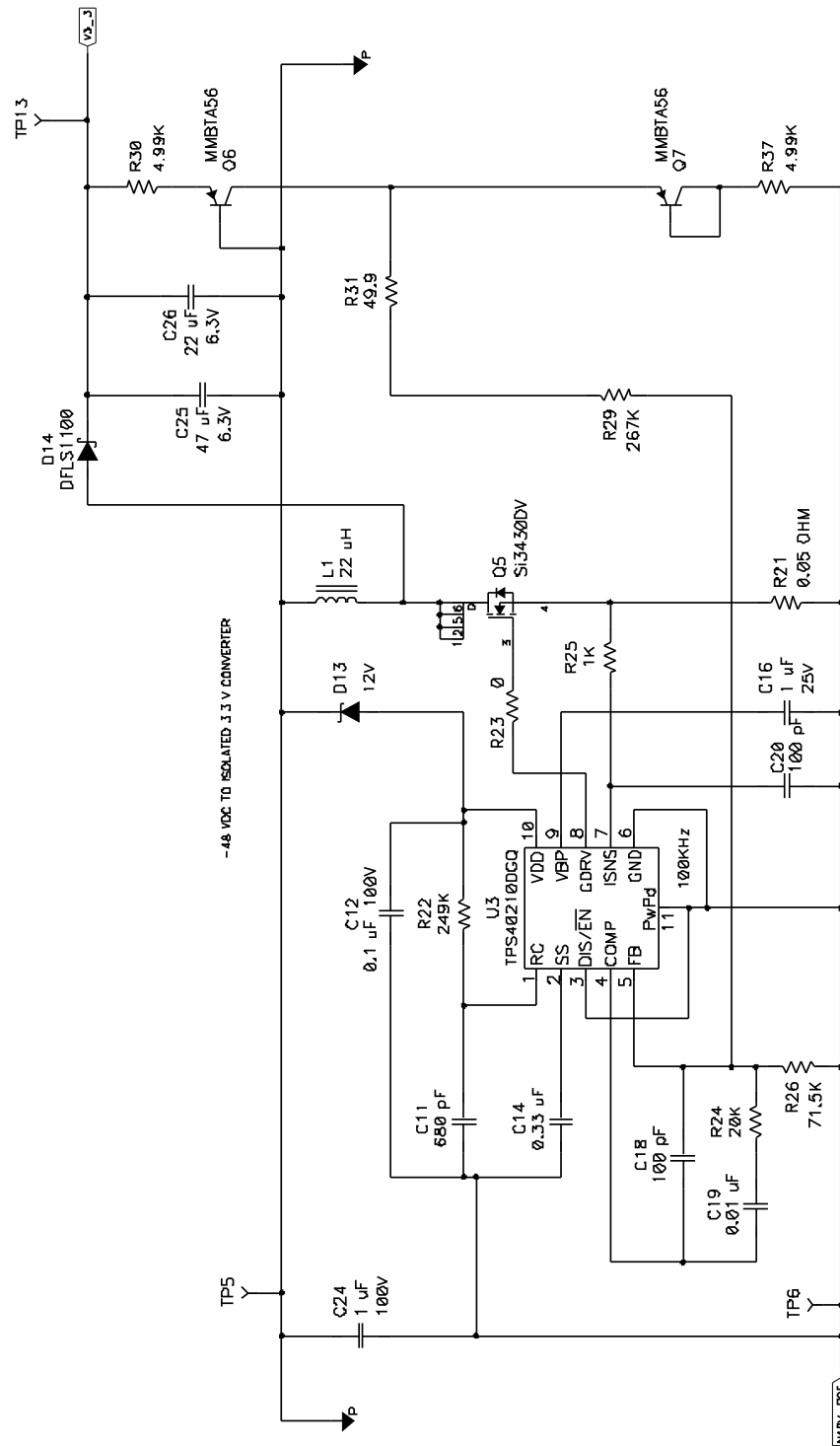

Figure 8. HPA676 Schematic 4

14 Layout HPA676

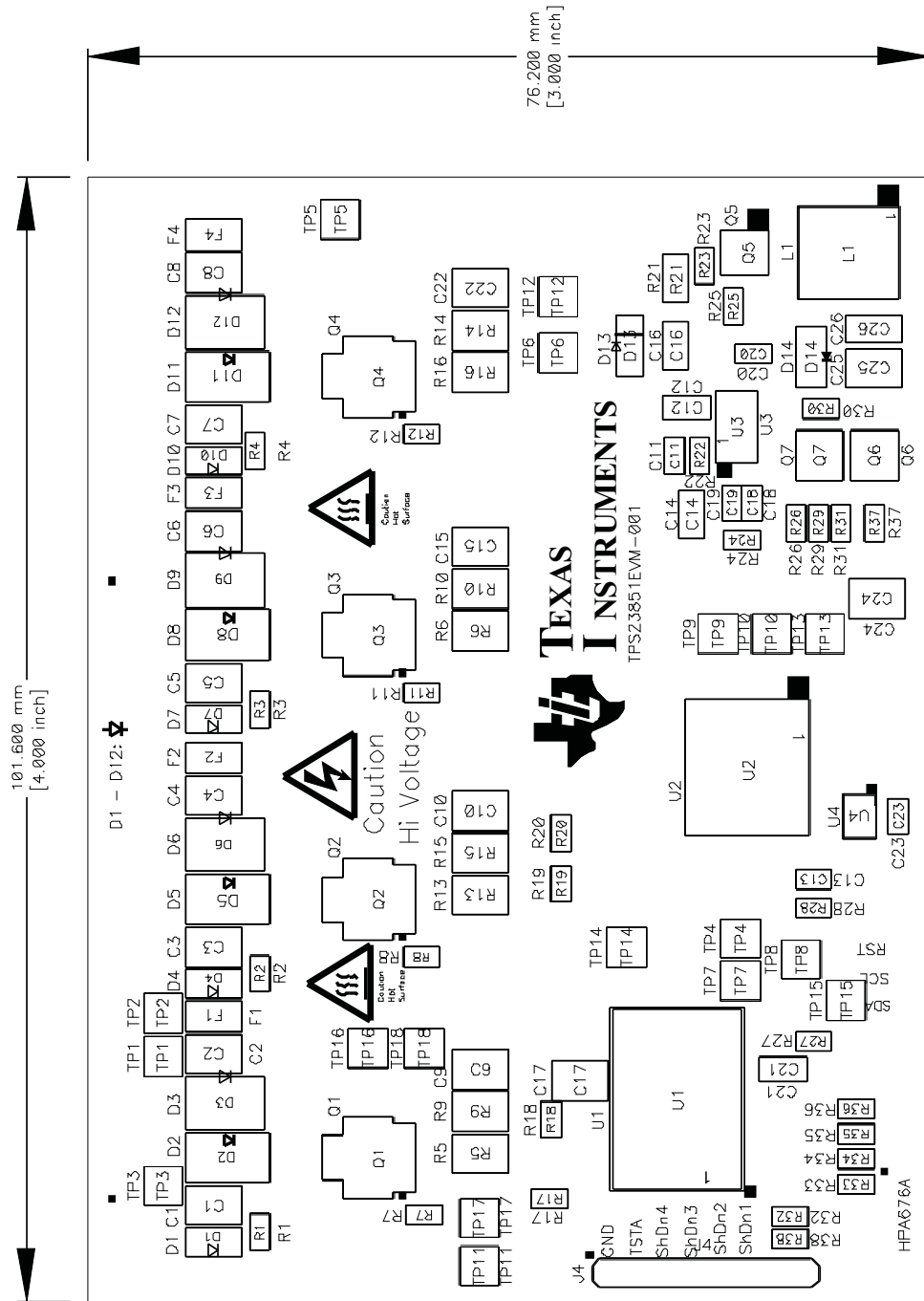

Figure 9. Board Layout (top view)

**15 HPA676 List of Materials**
**Table 5. HPA676 List of Materials**

COUNT	REF DES	DESCRIPTION	PART NUMBER	MFG
4	C1, C3, C5, C7	Capacitor, ceramic, 100 V, X7R, 10%, 0.47 $\mu$ F, 1210	STD	STD
1	C11	Capacitor, ceramic, 50 V, C0G, 5%, 680 pF, 0603	STD	STD
1	C12	Capacitor, ceramic, 100 V, X7R, 10%, 0.1 $\mu$ F, 0805	STD	STD
2	C13, C23, C19	Capacitor, ceramic, 16 V, X7R, 10%, 0.01 $\mu$ F, 0603	STD	STD
1	C14	Capacitor, Ceramic, 25 V, X7R, 10%, 0.33 $\mu$ F, 0805	STD	STD
1	C16, C21	Capacitor, ceramic, 25 V, X7R, 10%, 1 $\mu$ F, 0805	STD	STD
2	C18, C20	Capacitor, ceramic, 50 V, C0G, 5%, 100 pF, 0603	STD	STD
9	C2, C4, C6, C8, C9, C10, C15, C17, C22	Capacitor, ceramic, 100 V, X7R, 10%, 0.1 $\mu$ F, 1210	STD	STD
1	C24	Capacitor, ceramic, 100 V, X7R, 10%, 1 $\mu$ F, 1210	STD	STD
1	C25	Capacitor, ceramic, 6.3 V, X7R, 20%, 47 $\mu$ F, 1210	STD	STD
1	C26	Capacitor, ceramic, 6.3 V, X7R, 20%, 22 $\mu$ F, 1206	STD	STD
4	D1, D4, D7, D10	Diode, switch, 100 V, 400 mW, SOD-123	1N4148W-7-F	Diodes Inc
1	D13	Diode, ZENER, 12 V, 500 mW, SOD-123	MMSZ5242BT1G	On Semi
1	D14	Diode, Schottky, 100 V, 1 A, PowerDI 123	DFLS1100-7	Diodes, Inc.
4	D2, D5, D8, D11	Diode, LDO, 1.5 A, 100 V, overload, SMB	S2B-13-F	Diodes, Inc.
4	D3, D6, D9, D12	TVS unidirect, 600 W, 58 V, D0-214AA	SMBJ58A-13-F	Diodes, Inc.
4	F1, F2, F3, F4	Fuse, slim, SLO-BLO, 1.5 A, 63 V, 1.5 A, 1206	046801.5NR	Littelfuse
3	J1, J2, J3	Header, male, 10 pin, 100-mil spacing, 0.100 inch x 10 inch	PEC10SAAN	Sullins
1	J4	Header, male, 8 pin, 100-mil spacing, 0.100 inch x 8 inch	PEC08SAAN	Sullins
1	L1	Inductor shield PWR, 22 $\mu$ H, 0.300 in. sq.	DR74-220-R	Coiltronics
4	Q1, Q2, Q3, Q4	MOSFET, N-channel, 100 V 2.3 A, SOT-223	IRFM120ATF	Fairchild
1	Q5	MOSFET, N-channel, 100 V, 1.8 A, TSOP-6	SI3430DV-T1-E3	Vishay
2	Q6, Q7	Transistor, PNP, 80 V, MMBTA56, SOT23	MMBTA56-7-F	Diodes Inc.
5	R1, R2, R3, R4, R25	Resistor, 1/10 W, 1%, 1 k $\Omega$ , 0603	STD	STD
5	R17, R18, R19, R20, R32	Resistor, 1/10 W, 1%, 10 k $\Omega$ , 0603	STD	STD
0	R38	Resistor, 1/10 W, 1%, 10 k $\Omega$ , 0603	STD	STD
1	R21	Resistor, 1/8 W, 1%, 0.05 $\Omega$ , 0805	STD	STD
1	R22	Resistor, 1/10 W, 1%, 249 k $\Omega$ , 0603	STD	STD
1	R23, R33, R34, R35, R36	Resistor, 1/10 W, 0 $\Omega$ , 0603	STD	STD
1	R24	Resistor, 1/10 W, 1%, 20 k $\Omega$ , 0603	STD	STD
1	R26	Resistor, 1/10 W, 1%, 71.5 k $\Omega$ , 0603	STD	STD
1	R28	Resistor, 1/10 W, 1%, 4.7 k $\Omega$ , 0603	STD	STD
1	R29	Resistor, 1/10 W, 1%, 267 k $\Omega$ , 0603	STD	STD

**Table 5. HPA676 List of Materials (continued)**

COUNT	REF DES	DESCRIPTION	PART NUMBER	MFG
2	R30, R37	Resistor, 1/10 W, 1%, 4.99 k $\Omega$ , 0603	STD	STD
1	R31	Resistor, 1/10 W, 1%, 49.9 $\Omega$ , 0603	STD	STD
8	R5, R6, R9, R10, R13, R14, R15, R16	Resistor, 1/3 W, 1%, 1 $\Omega$ , 1210	STD	STD
5	R7, R8, R11, R12, R27	Resistor, 1/10 W, 1%, 10 $\Omega$ , 0603	STD	STD
18	TP1, TP2, TP3, TP4, TP5, TP6, TP7, TP8, TP9, TP10, TP11, TP12, TP13, TP14, TP15, TP16, TP17, TP18	Test point, white, thru hole, 5012, 0.125 inch x 0.125 inch	5012	Keystone
1	U1	quad IEEE 802.3 PoE PSE controller, SSOP	TPS23851DCE	TI
1	U2	1-Mbps digital isolators, SO-16	ISO7241ADW	TI
1	U3	4.5V-52V VIN Current Mode Boost Controller, MSOP-10PP	TPS40210DGQ	TI
1	U4	BUFF/DVR DL non-inv SC706, SOP-6	SN74LVC2G07DCKR	TI
1	--	PCB, 4 inch x 3 inch x 0.032 inch	Any	Any
1	Sub Assembly	PCB, 7.1 inch x 6.6 inch x 0.062 inch	HPA677	TI

16 HPA677 Schematics

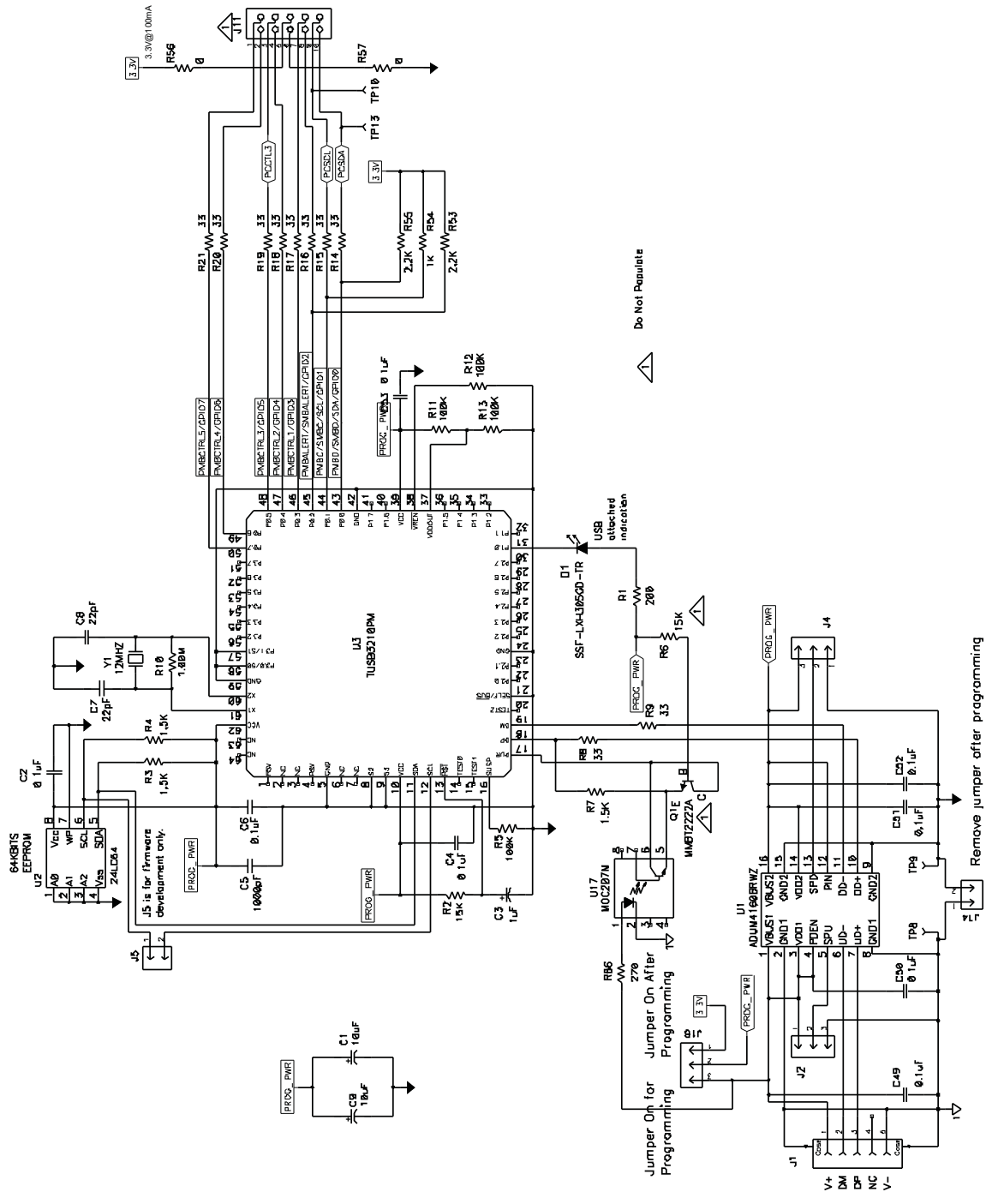

Figure 10. HPA677 Schematic 1



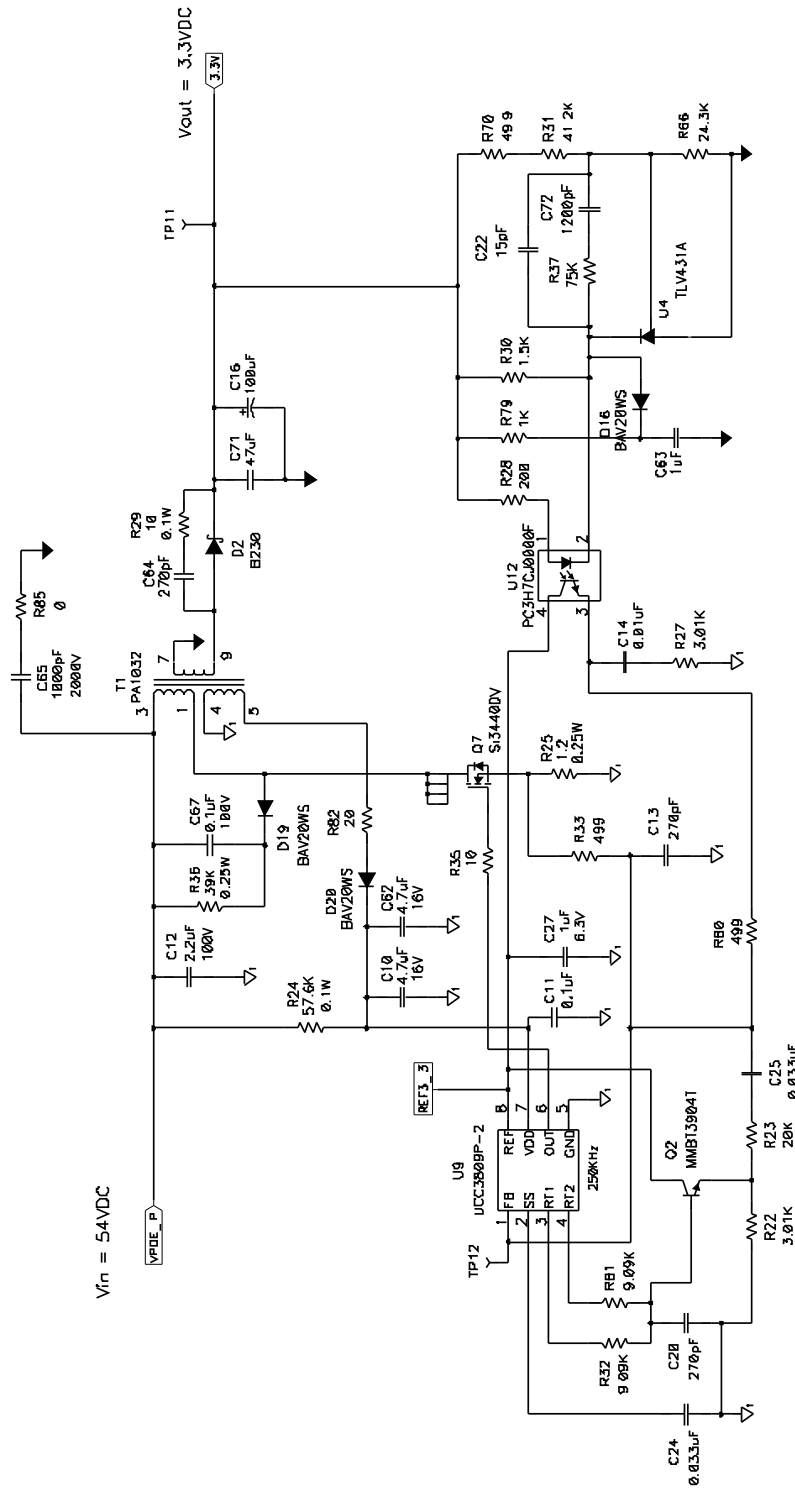

Figure 11. HPA677 Schematic 2



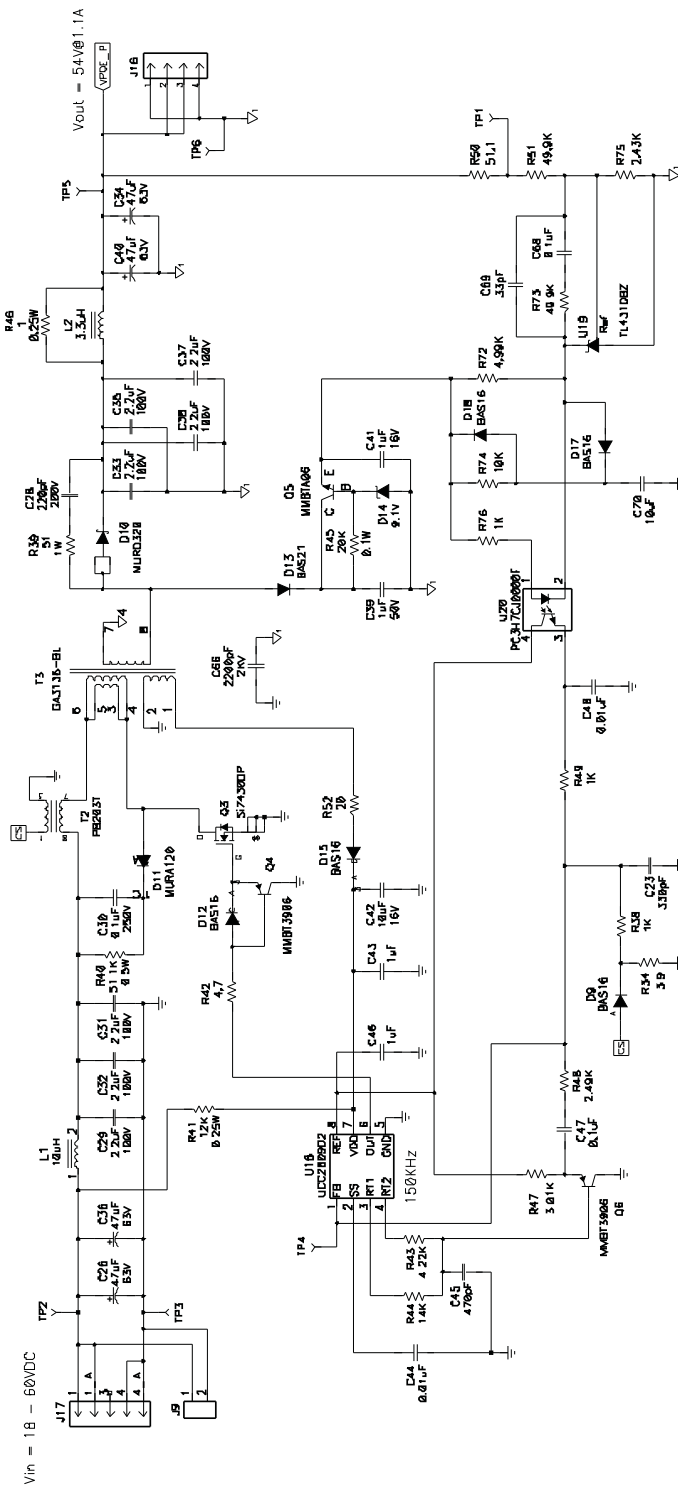

Figure 13. HPA677 Schematic 4

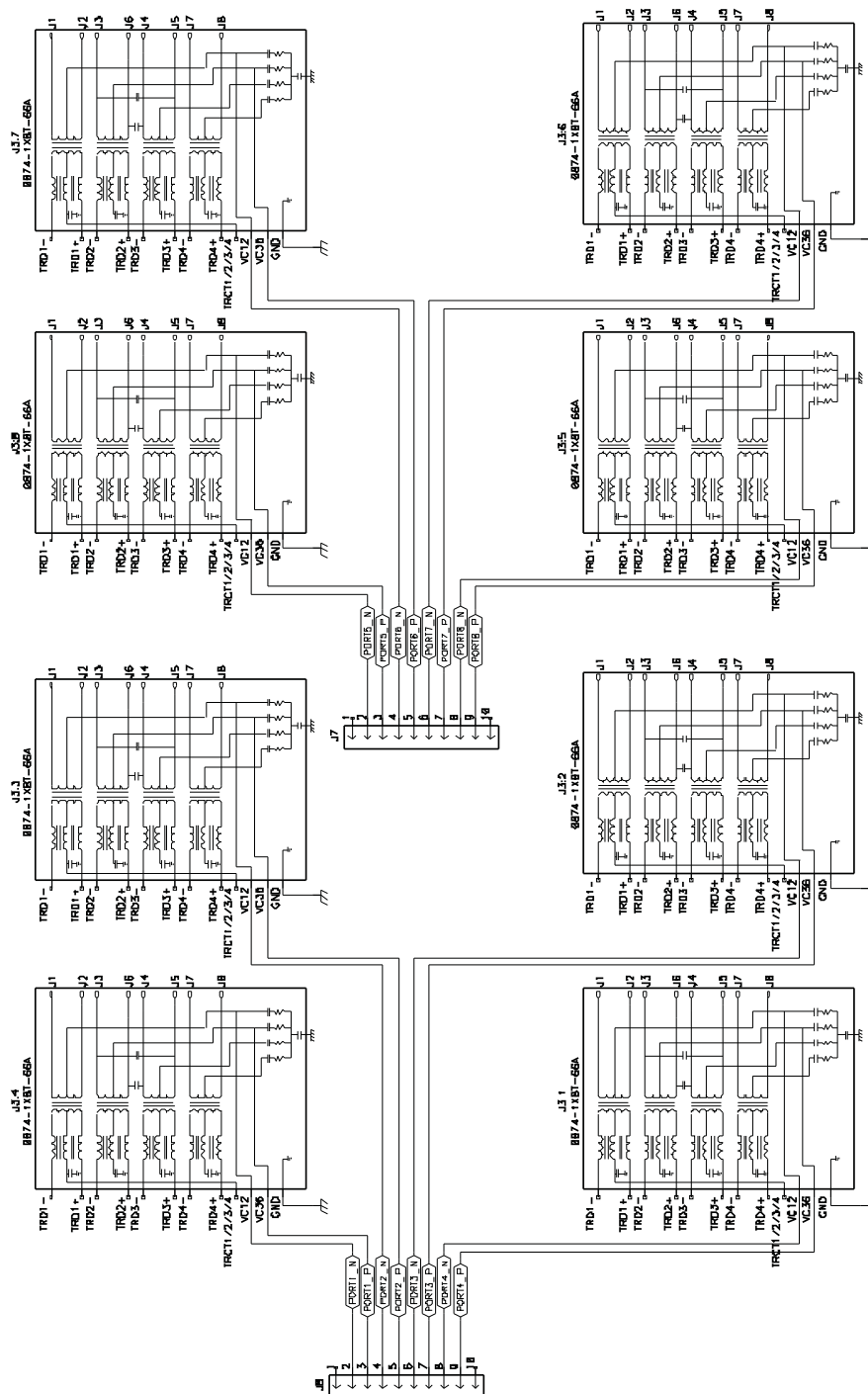

Figure 14. HPA677 Schematic 5

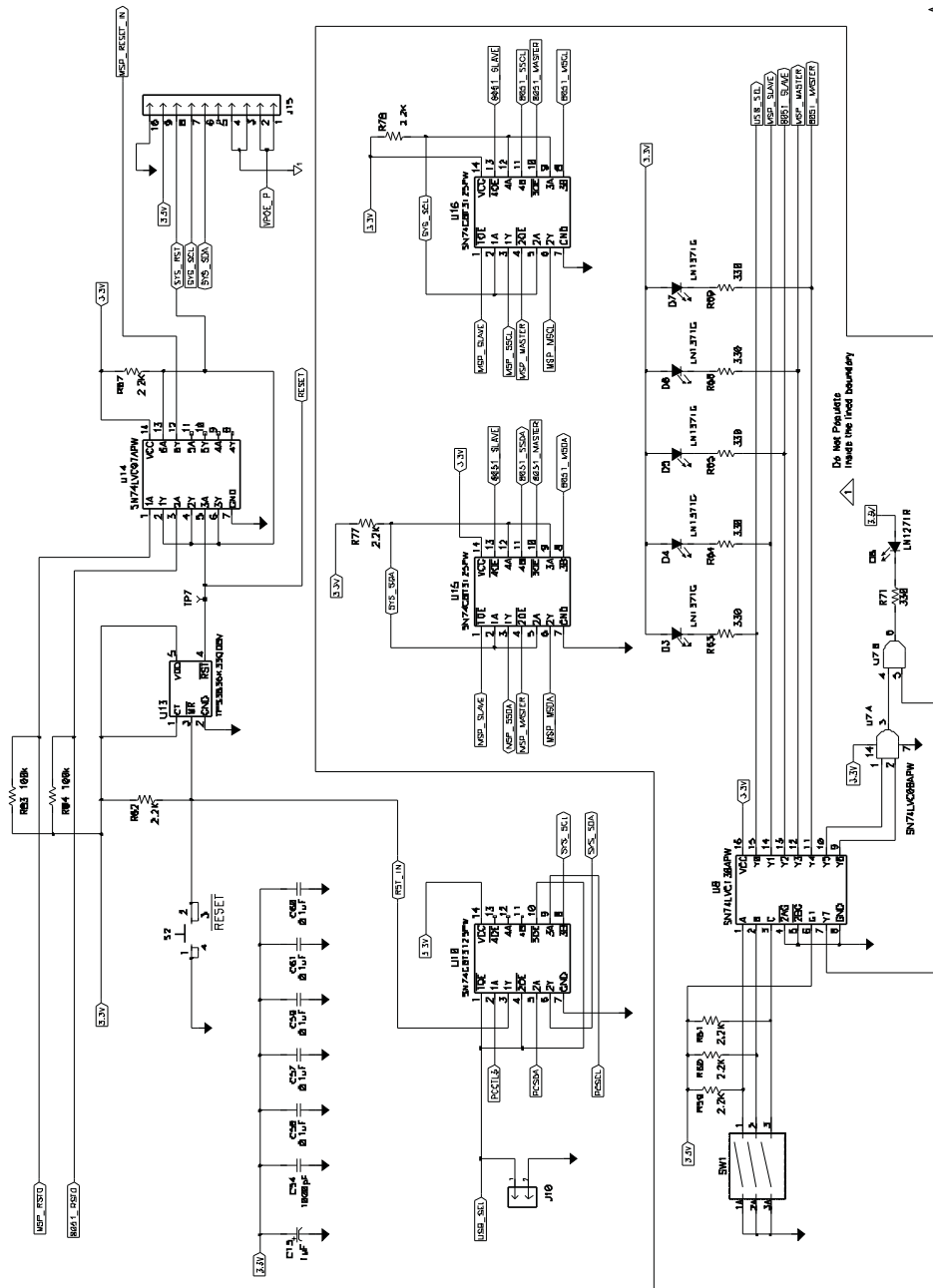

Figure 15. HPA677 Schematic 6

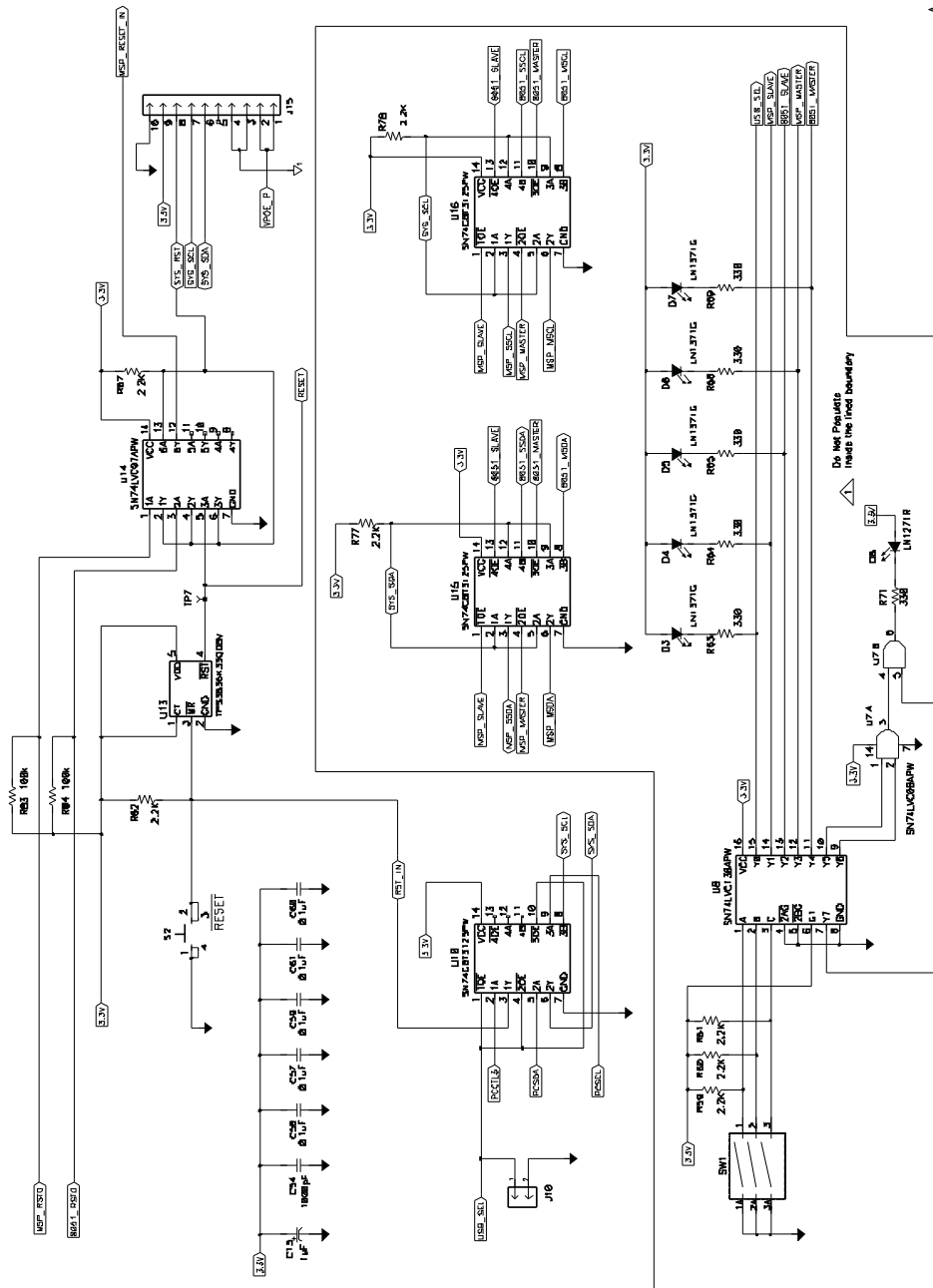

Figure 16. HPA677 Schematic 7

## 17 HPA677 List of Materials

**Table 6. HPA677 List of Materials**

COUNT	REF DES	DESCRIPTION	PART NUMBER	MFG
2	C1, C9	Capacitor, tant, 10 V, 20%, 10 $\mu$ F, 3216	293D106X0010A2TE3	Vishay
2	C10, C62	Capacitor, ceramic, 16 V, X7R, 10%, 4.7 $\mu$ F, 0805	STD	STD
8	C12, C29, C31, C32, C33, C35, C37, C38	Capacitor, ceramic, X7R, 100 V, 10%, 2.2 $\mu$ F, 1210	STD	STD
1	C13	Capacitor, ceramic, 270 pF, 50 V, C0G, 5%, 270 pF, 0402	STD	STD
1	C14	Capacitor, ceramic, 25 V, X7R, 10%, 0.01 $\mu$ F, 0402	STD	STD
1	C16	Capacitor, POSCAP, 6.3 V, 45 m $\Omega$ , 20%, 100 $\mu$ F, 6032 (C)	6TPB100MC	Sanyo
0	C19	Capacitor, ceramic, X7R, 50 V, 10%, 2.2 nf, 0603	STD	STD
13	C2, C4, C6, C11, C49, C50, C51, C52, C53, C57, C58, C59, C60, C61	Capacitor, ceramic, 25 V, X7R, 10%, 0.1 $\mu$ F, 0603	STD	STD
0	C17	Capacitor, ceramic, 25 V, X7R, 10%, 0.1 $\mu$ F, 0603	STD	STD
1	C20	Capacitor, ceramic, 50 V, C0G, 5%, 270 pF, 0402	STD	STD
1	C22	Capacitor, ceramic, 50 V, 5%, C0G, 15 pF, 0402	STD	STD
1	C23	Capacitor, ceramic, 50 V, NP0, 10%, 330 pF, 0603	STD	STD
2	C24, C25	Capacitor, Ceramic, 25 V, X7R, 10%, 0.033 $\mu$ F, 0402	STD	STD
4	C26, C34, C36, C40	Capacitor, ELECT, 63 V, FK, 47 $\mu$ F, 8 mm x 10.2 mm	EEV-FK1J470P	Panasonic
1	C27	Capacitor, ceramic, 6.3 V, X5R, 10%, 1 $\mu$ F, 0603	STD	STD
1	C28	Capacitor, ceramic, 5%, 200 V, NP0, 220 pF, 1206	STD	STD
2	C3, C15	Capacitor, TANT, 16 V, 20%, 1 $\mu$ F, 3216	293D105X0016A2TE3	Vishay
0	C21	Capacitor, TANT, 16 V, 20%, 1 $\mu$ F, 3216	293D105X0016A2TE3	Vishay
1	C30	Capacitor, ceramic, X7R, 250 V, 10%, 0.1 $\mu$ F, 1206	STD	STD
1	C39	Capacitor, ceramic, 50 V, X7R, 10%, 1 $\mu$ F, 1206	STD	STD
1	C41	Capacitor, ceramic, 16 V, X7R, 10%, 1 $\mu$ F, 0603	STD	STD
1	C42	Capacitor, ceramic, 16 V, X7R, 10%, 10 $\mu$ F, 1210	STD	STD
2	C43, C46, C63	Capacitor, ceramic, 25 V, X7R, 10%, 1 $\mu$ F, 0805	STD	STD
2	C44, C48	Capacitor, ceramic, 50 V, 10%, X7R, 0.01 $\mu$ F, 0603	STD	STD
1	C45	Capacitor, ceramic, 50 V, X7R, 10%, 470 pF, 0603	STD	STD
2	C47, C68	Capacitor, ceramic, 25 V, X7R, 10%, 0.1 $\mu$ F, 0603	STD	STD
2	C5, C54	Capacitor, ceramic, 100 V, C0G, 5%, 1000 pF, 0805	STD	STD
0	C18	Capacitor, ceramic, 100 V, C0G, 5%, 1000 pF, 0805	STD	STD
1	C64	Capacitor, ceramic, 50 V, C0G, 5%, 270 pF, 0603	STD	STD
1	C65	Capacitor, ceramic, 2000 V, X7R, 10%, 1000 pF, 1206	STD	STD
1	C66	Capacitor, ceramic, 2000 V, X7R, 10%, 2200 pF, 1812	STD	STD
1	C67	Capacitor, ceramic, 100 V, X7R, 10%, 0.1 $\mu$ F, 0805	STD	STD
1	C69	Capacitor, ceramic, 50 V, C0G, 5%, 33 pF, 0603	STD	STD
2	C7, C8	Capacitor, ceramic, 50 V, C0G, 5%, 22 pF, 0603	STD	STD
0	C55, C56	Capacitor, ceramic, 50 V, C0G, 5%, 22 pF, 0603	STD	STD
1	C70	Capacitor, ceramic, 16 V, X7R, 10%, 10 $\mu$ F, 0805	STD	STD
1	C71	Capacitor, ceramic, 6.3 V, X5R, 20%, 47 $\mu$ F, 1206	STD	STD

**Table 6. HPA677 List of Materials (continued)**

COUNT	REF DES	DESCRIPTION	PART NUMBER	MFG
1	C72	Capacitor, ceramic, 50 V, 10%, X7R, 1200 pF, 0402	STD	STD
1	D1	LED, ALINGAP, RA, green, DIF, 565 NM, 0.250 inch x 0.250 inch	SSF-LXH305SGD-TR	Lumex
1	D10	Diode, ultra fast, 3 A, 200 V, TO-252AA	MURD320	On Semi
1	D11	Diode, ultra fast, 1 A, 200 V, SMA	MURA120T3G	On Semi
1	D13	Diode, GP, 250 V, SOT23	BAS21	Fairchild
1	D14	Diode, ZENER, 9.1 V, 225 mW, 9.1 V, SOT-23	BZX84C9V1LT1G	On Semi
3	D16, D19, D20	Diode, GP, 200 V, 200 mA, SOD-323	BAV20WS-TP	Micro Commercial
1	D2	Diode, SCHOTTKY, 2 A, 30 V, SMB	MBRS230LT3G	On Semi
0	D3, D4, D5, D6, D7	LED, GRN, S-TYPE, GULL WING, 0.068 inch x 0.049 inch	LNJ306G5TR02	Panasonic
0	D8	LED, red, S-GW type, SMD, 0.068 inch x 0.049 inch	LN1271RALTRP	Panasonic
5	D9, D12, D15, D17, D18	Diode, switch, 75 V, 200 mA, SOT-23	BAS16LT3G	On Semi
1	J1	Connector, recpt, USB-B, mini, 5 pins, SMT, 0.354 inch x 0.303 inch	UX60-MB-5ST	Hiroise Electrical Co
2	J10, J14	Header, male, 2 pin, 100-mil spacing, 0.100 inch x 2 inch	PEC02SAAN	Sullins
0	J11	Connector, male, right angle, 2 x 5 pin, 100-mil spacing, 4 wall, 0.607 inch x 0.484 inch	9-146257-0-05	Tyco
0	J12	Header, male, 8 pin, 100-mil spacing, 0.100 inch x 8	PEC08SAAN	Sullins
0	J13	Header, male, 2 x 7 pin, 100-mil spacing, 0.100 inch x 2 inch x 7 inch	PEC07DAAN	Sullins
1	J16	Term, blk, hdr, PCB, 4POS, 3.81 mm, green, 0.280 inch x 1.000 inch	1793810000	Weidmuller
1	J17	Connector, DC power jack, ra, 3 position, 0.394 inch x 0.433 inch	JPD1135-509-7F	Foxconn
1	J3	Connector, PoE, 1 x 8 gigabit Magjack, 1.550 inch x 4.550 inch	0874-1X8T-66A	Bell
2	J4, J18	Header, male, 3 pin, 100-mil spacing, 0.100 inch x 3 inch	PEC03SAAN	Sullins
0	J6	Header, male, 4 pin, 100-mil spacing, 0.100 inch x 4 inch	PEC04SAAN	Sullins
3	J7, J8, J15	Header, female 10 pin, 100-mil spacing, 0.100 inch x 10 inch	PPTC101LFBN-RC	Sullins
1	J9	Terminal block, 5.08 mm, vertical, 2 position, 0.40 inch x 0.35 inch	ED120/2DS	On Shore Technology
1	L1	Inductor, SMT, 3.8 A, 38 mΩ, 10 μH, 9.4 mm x 12.95 mm	DO3316P-103ML	Coilcraft
1	L2	Inductor, SMT, 2 A, 80 mΩ, 3.3 μH, 0.26 inch x 0.09 inch	DO1608C-332ML	Coilcraft
0	Q1	Transistor, NPN, GP, 40 V, SOT-23	MMBT2222A-TP	Micro Commercial
1	Q2	Transistor, GP, SS, NPN, 40 V, SC-75	MMBT3904TT1G	On Semi
1	Q3	MOSFETs, 150 V, 26 A, 64 W, 45 mΩ at 10 V, PWRPAK S0-8	Si7430DP-T1-E3	Vishay
2	Q4, Q6	Transistor, SS, PNP, 40 V, 300 mW, SOT23	MMBT3906-TP	Micro Commercial
1	Q5	Transistor, NPN, 80 V, SOT23	MMBTA06-7-F	Diodes Inc
1	Q7	MOSFET, N-channel, 150 V, 1.2 A, TSOP-6	SI3440DV-T1-E3	Vishay
1	R1	Resistor, 1/10 W, 1%, 200, 603	STD	STD
1	R10	Resistor, 1/10 W, 1%, 1.00M, 603	STD	STD
4	R11, R5, R12, R13	Resistor, 1/10 W, 1%, 100K, 603	STD	STD
1	R2	Resistor, 1/10 W, 1%, 15K, 603	STD	STD
0	R6	Resistor, 1/10 W, 1%, 15K, 603	STD	STD



**Table 6. HPA677 List of Materials (continued)**

COUNT	REF DES	DESCRIPTION	PART NUMBER	MFG
2	R22, R27	Resistor, 1/16 W, 1%, 3.01K, 402	STD	STD
1	R23	Resistor, 1/16 W, 1%, 20K, 402	STD	STD
1	R24	Resistor, 1/8 W, 1%, 57.6K, 805	STD	STD
1	R25	Resistor, 1/4 W, 1%, 1.2, 1206	STD	STD
6	R53, R55, R62, R67, R77, R78	Resistor, 1/10 W, 1%, 2.2K, 603	STD	STD
0	R26, R58, R59, R60, R61	Resistor, 1/10 W, 1%, 2.2K, 603	STD	STD
1	R28	Resistor, 1/16 W, 1%, 200, 402	STD	STD
1	R29	Resistor, 1/8 W, 1%, 10, 805	STD	STD
3	R3, R4, R7	Resistor, 1/10 W, 1%, 1.5K, 603	STD	STD
1	R30	Resistor, 1/16 W, 1%, 1.5K, 402	STD	STD
1	R31	Resistor, 1/16 W, 1%, 41.2K, 402	STD	STD
2	R32, R81	Resistor, 1/16 W, 1%, 9.09K, 402	STD	STD
2	R33, R80	Resistor, 1/16 W, 1%, 499, 402	STD	STD
1	R34	Resistor, 1/8 W, 1%, 3.9, 805	STD	STD
1	R35	Resistor, 1/10 W, 1%, 10, 603	STD	STD
1	R36	Resistor, 1/4 W, 1%, 39K, 1206	STD	STD
1	R37	Resistor, 1/16 W, 1%, 75K, 402	STD	STD
4	R38, R49, R76, R54	Resistor, 1/10 W, 1%, 1K, 603	STD	STD
1	R39	Resistor, 1 W, 1%, 51, 2512	STD	STD
1	R40	Resistor, 1/2 W, 1%, 51.1K, 2010	STD	STD
1	R41	Resistor, 1/4 W, 1%, 12K, 1206	STD	STD
1	R42	Resistor, 1/10 W, 1%, 4.7, 603	STD	STD
1	R43	Resistor, 1/10 W, 1%, 4.22K, 603	STD	STD
1	R44	Resistor, 1/10 W, 1%, 14K, 603	STD	STD
1	R45	Resistor, 1/8 W, 1%, 20K, 805	STD	STD
1	R46	Resistor, 1/4 W, 1%, 1, 1206	STD	STD
1	R47	Resistor, 1/10 W, 1%, 3.01K, 603	STD	STD
1	R48	Resistor, 1/10 W, 1%, 2.49K, 603	STD	STD
1	R50	Resistor, 1/10 W, 1%, 51.1, 603	STD	STD
2	R51, R73	Resistor, 1/10 W, 1%, 49.9K, 603	STD	STD
2	R52, R82	Resistor, 1/10 W, 1%, 20, 603	STD	STD
2	R56, R57	Resistor, 1/10 W, 0, 603	STD	STD
0	R63, R64, R65, R68, R69, R71	Resistor, 1/8 W, 1%, 330, 805	STD	STD
1	R66	Resistor, 1/16 W, 1%, 24.3K, 402	STD	STD
1	R70	Resistor, 1/16 W, 1%, 49.9, 402	STD	STD
1	R72	Resistor, 1/10 W, 1%, 4.99K, 603	STD	STD
1	R74	Resistor, 1/10 W, 1%, 10K, 603	STD	STD
1	R75	Resistor, 1/10 W, 1%, 2.43K, 603	STD	STD
1	R79	Resistor, 1/16 W, 1%, 1K, 402	STD	STD

**Table 6. HPA677 List of Materials (continued)**

COUNT	REF DES	DESCRIPTION	PART NUMBER	MFG
10	R8, R9, R14, R15, R16, R17, R18, R19, R20, R21	Resistor, 1/10 W, 1%, 33, 603	STD	STD
2	R83, R84	Resistor, 1/10 W, 1%, 100k, 603	STD	STD
1	R85	Resistor, metal film, 1/4 watt, $\pm$ 5%, 0, 1206	STD	STD
1	R86	Resistor, 1/10W, 1%, 270, 603	STD	STD
0	S1	SWITCH, TACT, 2.36MM, SILV J-LEAD, 0.245 inch x 0.251 inch	KT11P2JM34LFS	STD
1	S2	SWITCH, TACT, 2.36MM, SILV J-LEAD, Reset, 0.245 inch x 0.251 inch	KT11P2JM34LFS	STD
0	SW1	SWITCH, SPST, GOLD, 3 SEC, Mode Select, 0.380 inch x 0.385 inch	206-3	STD
1	T1	Transformer, Flyback, 0.490 inch X 0.450 inch	PA1032	PULSE
1	T2	Transformer, Current Sense, 6A, 100Khz, 30:1, 0.330 inch x 0.360 inch	P8203T	Pulse
1	T3	Transformer, 1.053 inch x 1.285 inch	GA3136-BL	Coilcraft
13	TP1, TP2, TP3, TP4, TP5, TP6, TP7, TP8, TP9, TP10, TP11, TP12, TP13	Test Point, White, Thru Hole, 5012, 0.125 inch x 0.125 inch	5012	Keystone
1	U1	USB, ISOLATOR, FULL/LOW, SO-16	ADUM4160BRWZ	AD
0	U11, U15, U16	QUAD, FET, BUS, SW, TSSOP-14	SN74CBT3125PW	TI
2	U12, U20	PHOTOCOUPLER, TRAN OUT, MF4	PC3H7CJ0000F	STD
1	U13	Nanopower, Supervisory Circuits, SOT23-5	TPS3833QDBV	TI
1	U14	Hex Buffers/Drivers With Open-Drain Outputs, TSSOP-14	SN74LVC07APW	TI
1	U17	Optocoupler Trans Output, 60mA, 70V, SO	MOC207M	Fairchild
1	U18	Economy Primary-Side Controller, SO8	UCC2809D-2	TI
1	U19	PREC SHUNT, REG ADJ, SOT23-3	TL431IDBZR	TI
1	U2	SRL EEPROM, 8KX8, 2.5V, SO8	24LC64F-I/SN	TI
1	U3	USB CNTRLR STORAGE, TUSB3210PM, 0.480 inch x 0.480 inch	24LC64F-I/SN	TI
1	U4	Shunt Regulator, 1.24V, Ref, 6V, 10mA, 1%, SOT23-5	TLV431ACDBVR	TI
0	U5	MCU FLASH 32K, PLCC, 8051	AT89C51IC2-SLSUL	TI
0	U6	MCU 16BIT, 2K, FLASH, TSSOP-14	MSP430F2012IPWR	TI
1	U7	QUAD, 2-IN AND GATE, TSSOP-14	SN74LVC08APWR	TI
0	U8	3-8 DECODER/DEMUX, TSSOP-16	SN74LVC138APWR	TI
1	U9	PRIMARY-SIDE CTRLR, MSOP-8	UCC3809P-2	TI
1	Y1	Crystal, 20pF, +/- 50PPM at 25°C, 12MHZ, 0.185 inch x 0.532 inch	CY12BPSMD	Cypress
0	Y2	Crystal, 20pF, +/- 50PPM at 25°C, 12MHZ, 0.185 inch x 0.532 inch	CY12BPSMD	Cypress
1	--	PCB, 7 inch x 6.5 inch x 0.032 inch		
4	--	Shunt, 100 mil, black, 0.100		
5	-REF-	Bumper, rubber	2566	SPC Tech

## Evaluation Board/Kit Important Notice

Texas Instruments (TI) provides the enclosed product(s) under the following conditions:

This evaluation board/kit is intended for use for **ENGINEERING DEVELOPMENT, DEMONSTRATION, OR EVALUATION PURPOSES ONLY** and is not considered by TI to be a finished end-product fit for general consumer use. Persons handling the product(s) must have electronics training and observe good engineering practice standards. As such, the goods being provided are not intended to be complete in terms of required design-, marketing-, and/or manufacturing-related protective considerations, including product safety and environmental measures typically found in end products that incorporate such semiconductor components or circuit boards. This evaluation board/kit does not fall within the scope of the European Union directives regarding electromagnetic compatibility, restricted substances (RoHS), recycling (WEEE), FCC, CE or UL, and therefore may not meet the technical requirements of these directives or other related directives.

Should this evaluation board/kit not meet the specifications indicated in the User's Guide, the board/kit may be returned within 30 days from the date of delivery for a full refund. **THE FOREGOING WARRANTY IS THE EXCLUSIVE WARRANTY MADE BY SELLER TO BUYER AND IS IN LIEU OF ALL OTHER WARRANTIES, EXPRESSED, IMPLIED, OR STATUTORY, INCLUDING ANY WARRANTY OF MERCHANTABILITY OR FITNESS FOR ANY PARTICULAR PURPOSE.**

The user assumes all responsibility and liability for proper and safe handling of the goods. Further, the user indemnifies TI from all claims arising from the handling or use of the goods. Due to the open construction of the product, it is the user's responsibility to take any and all appropriate precautions with regard to electrostatic discharge.

**EXCEPT TO THE EXTENT OF THE INDEMNITY SET FORTH ABOVE, NEITHER PARTY SHALL BE LIABLE TO THE OTHER FOR ANY INDIRECT, SPECIAL, INCIDENTAL, OR CONSEQUENTIAL DAMAGES.**

TI currently deals with a variety of customers for products, and therefore our arrangement with the user **is not exclusive.**

TI assumes **no liability for applications assistance, customer product design, software performance, or infringement of patents or services described herein.**

Please read the User's Guide and, specifically, the Warnings and Restrictions notice in the User's Guide prior to handling the product. This notice contains important safety information about temperatures and voltages. For additional information on TI's environmental and/or safety programs, please contact the TI application engineer or visit [www.ti.com/esh](http://www.ti.com/esh).

No license is granted under any patent right or other intellectual property right of TI covering or relating to any machine, process, or combination in which such TI products or services might be or are used.

## FCC Warning

This evaluation board/kit is intended for use for **ENGINEERING DEVELOPMENT, DEMONSTRATION, OR EVALUATION PURPOSES ONLY** and is not considered by TI to be a finished end-product fit for general consumer use. It generates, uses, and can radiate radio frequency energy and has not been tested for compliance with the limits of computing devices pursuant to part 15 of FCC rules, which are designed to provide reasonable protection against radio frequency interference. Operation of this equipment in other environments may cause interference with radio communications, in which case the user at his own expense will be required to take whatever measures may be required to correct this interference.

## EVM Warnings and Restrictions

It is important to operate this EVM within the input voltage range of 40 V to 60 V and the output voltage range of 40 V to 60 V .

Exceeding the specified input range may cause unexpected operation and/or irreversible damage to the EVM. If there are questions concerning the input range, please contact a TI field representative prior to connecting the input power.

Applying loads outside of the specified output range may result in unintended operation and/or possible permanent damage to the EVM. Please consult the EVM User's Guide prior to connecting any load to the EVM output. If there is uncertainty as to the load specification, please contact a TI field representative.

During normal operation, some circuit components may have case temperatures greater than 80° C. The EVM is designed to operate properly with certain components above 80° C as long as the input and output ranges are maintained. These components include but are not limited to linear regulators, switching transistors, pass transistors, and current sense resistors. These types of devices can be identified using the EVM schematic located in the EVM User's Guide. When placing measurement probes near these devices during operation, please be aware that these devices may be very warm to the touch.

Mailing Address: Texas Instruments, Post Office Box 655303, Dallas, Texas 75265  
Copyright © 2011, Texas Instruments Incorporated

## IMPORTANT NOTICE

Texas Instruments Incorporated and its subsidiaries (TI) reserve the right to make corrections, modifications, enhancements, improvements, and other changes to its products and services at any time and to discontinue any product or service without notice. Customers should obtain the latest relevant information before placing orders and should verify that such information is current and complete. All products are sold subject to TI's terms and conditions of sale supplied at the time of order acknowledgment.

TI warrants performance of its hardware products to the specifications applicable at the time of sale in accordance with TI's standard warranty. Testing and other quality control techniques are used to the extent TI deems necessary to support this warranty. Except where mandated by government requirements, testing of all parameters of each product is not necessarily performed.

TI assumes no liability for applications assistance or customer product design. Customers are responsible for their products and applications using TI components. To minimize the risks associated with customer products and applications, customers should provide adequate design and operating safeguards.

TI does not warrant or represent that any license, either express or implied, is granted under any TI patent right, copyright, mask work right, or other TI intellectual property right relating to any combination, machine, or process in which TI products or services are used. Information published by TI regarding third-party products or services does not constitute a license from TI to use such products or services or a warranty or endorsement thereof. Use of such information may require a license from a third party under the patents or other intellectual property of the third party, or a license from TI under the patents or other intellectual property of TI.

Reproduction of TI information in TI data books or data sheets is permissible only if reproduction is without alteration and is accompanied by all associated warranties, conditions, limitations, and notices. Reproduction of this information with alteration is an unfair and deceptive business practice. TI is not responsible or liable for such altered documentation. Information of third parties may be subject to additional restrictions.

Resale of TI products or services with statements different from or beyond the parameters stated by TI for that product or service voids all express and any implied warranties for the associated TI product or service and is an unfair and deceptive business practice. TI is not responsible or liable for any such statements.

TI products are not authorized for use in safety-critical applications (such as life support) where a failure of the TI product would reasonably be expected to cause severe personal injury or death, unless officers of the parties have executed an agreement specifically governing such use. Buyers represent that they have all necessary expertise in the safety and regulatory ramifications of their applications, and acknowledge and agree that they are solely responsible for all legal, regulatory and safety-related requirements concerning their products and any use of TI products in such safety-critical applications, notwithstanding any applications-related information or support that may be provided by TI. Further, Buyers must fully indemnify TI and its representatives against any damages arising out of the use of TI products in such safety-critical applications.

TI products are neither designed nor intended for use in military/aerospace applications or environments unless the TI products are specifically designated by TI as military-grade or "enhanced plastic." Only products designated by TI as military-grade meet military specifications. Buyers acknowledge and agree that any such use of TI products which TI has not designated as military-grade is solely at the Buyer's risk, and that they are solely responsible for compliance with all legal and regulatory requirements in connection with such use.

TI products are neither designed nor intended for use in automotive applications or environments unless the specific TI products are designated by TI as compliant with ISO/TS 16949 requirements. Buyers acknowledge and agree that, if they use any non-designated products in automotive applications, TI will not be responsible for any failure to meet such requirements.

Following are URLs where you can obtain information on other Texas Instruments products and application solutions:

### Products

Audio	<a href="http://www.ti.com/audio">www.ti.com/audio</a>
Amplifiers	<a href="http://amplifier.ti.com">amplifier.ti.com</a>
Data Converters	<a href="http://dataconverter.ti.com">dataconverter.ti.com</a>
DLP® Products	<a href="http://www.dlp.com">www.dlp.com</a>
DSP	<a href="http://dsp.ti.com">dsp.ti.com</a>
Clocks and Timers	<a href="http://www.ti.com/clocks">www.ti.com/clocks</a>
Interface	<a href="http://interface.ti.com">interface.ti.com</a>
Logic	<a href="http://logic.ti.com">logic.ti.com</a>
Power Mgmt	<a href="http://power.ti.com">power.ti.com</a>
Microcontrollers	<a href="http://microcontroller.ti.com">microcontroller.ti.com</a>
RFID	<a href="http://www.ti-rfid.com">www.ti-rfid.com</a>
RF/IF and ZigBee® Solutions	<a href="http://www.ti.com/lprf">www.ti.com/lprf</a>

### Applications

Communications and Telecom	<a href="http://www.ti.com/communications">www.ti.com/communications</a>
Computers and Peripherals	<a href="http://www.ti.com/computers">www.ti.com/computers</a>
Consumer Electronics	<a href="http://www.ti.com/consumer-apps">www.ti.com/consumer-apps</a>
Energy and Lighting	<a href="http://www.ti.com/energy">www.ti.com/energy</a>
Industrial	<a href="http://www.ti.com/industrial">www.ti.com/industrial</a>
Medical	<a href="http://www.ti.com/medical">www.ti.com/medical</a>
Security	<a href="http://www.ti.com/security">www.ti.com/security</a>
Space, Avionics and Defense	<a href="http://www.ti.com/space-avionics-defense">www.ti.com/space-avionics-defense</a>
Transportation and Automotive	<a href="http://www.ti.com/automotive">www.ti.com/automotive</a>
Video and Imaging	<a href="http://www.ti.com/video">www.ti.com/video</a>
Wireless	<a href="http://www.ti.com/wireless-apps">www.ti.com/wireless-apps</a>

TI E2E Community Home Page

[e2e.ti.com](http://e2e.ti.com)

Mailing Address: Texas Instruments, Post Office Box 655303, Dallas, Texas 75265  
Copyright © 2011, Texas Instruments Incorporated