

TPS53128 Buck Controller Evaluation Module User's Guide



ABSTRACT

The TPS53128EVM-620 evaluation module presents an easy-to-use reference design for a common dual-output power supply using the TPS53128 controller in cost-sensitive applications.

Table of Contents

1 Introduction	3
1.1 Description	3
1.2 Application	3
1.3 Features	3
2 Electrical Performance Specifications	4
3 Schematics	5
4 Connector and Test Point Descriptions	6
4.1 Enable Switches (SW1 and SW2)	6
4.2 Switching Frequency Select Switch (SW3)	6
4.3 Test Point Descriptions	6
5 Test Setup	8
5.1 Equipment	8
5.2 Recommended Setup	8
6 Test Procedure	10
6.1 Start-Up Procedure	10
6.2 Line/Load Regulation and Efficiency Measurement Procedure	10
6.3 Output Ripple Voltage Measurement Procedure	10
6.4 Shutdown Procedure	10
7 Performance Data and Typical Characteristic Curves	11
7.1 Efficiency	11
7.2 Line and Load Regulation	11
7.3 Output Voltage Ripple	12
7.4 Switch Node Waveforms	12
8 EVM Assembly Drawings and Layout	13
9 Bill of Materials	17
10 Revision History	18

List of Figures

Figure 3-1. TPS53128EVM-620 Schematic	5
Figure 4-1. Tip and Barrel Measurement for Output Voltage Ripple	7
Figure 5-1. TPS53128EVM-620 Recommended Test Setup	9
Figure 7-1. Efficiency vs Load	11
Figure 7-2. Efficiency vs Load	11
Figure 7-3. Output Voltage vs Load	11
Figure 7-4. Output Voltage vs Load	11
Figure 7-5. Output Voltage Ripple	12
Figure 7-6. Output Voltage Ripple	12
Figure 7-7. Switching Waveform	12
Figure 7-8. Switching Waveform	12
Figure 8-1. Top Assembly	13
Figure 8-2. Bottom Assembly	14
Figure 8-3. Top Layer	14
Figure 8-4. Bottom Layer	15

Figure 8-5. Internal Layer 1.....	15
Figure 8-6. Internal Layer 2.....	16

List of Tables

Table 2-1. TPS53128EVM-620 Electrical and Performance Specifications.....	4
Table 4-1. TPS53128EVM-620 Test Points Description.....	6
Table 9-1. TPS53128EVM-620 Bill of Materials.....	17

Trademarks

D-CAP2™ is a trademark of Texas Instruments.

All trademarks are the property of their respective owners.

1 Introduction

1.1 Description

The TPS53128EVM-620 evaluation board provides the user with a convenient way to evaluate the TPS53128 dual D-CAP2™ mode control step-down controller in a realistic cost-sensitive application. Providing both a low core-type 1.05-V and I/O type 1.8-V output at up to 4 A from a loosely regulated 12-V (8-V to 22-V) source, the TPS53128EVM-620 includes switches and test points to assist a user in evaluating the performance of the TPS53128 controller in their application.

1.2 Application

- Digital television
- Set-top box
- DSL and cable modems
- Cost-sensitive digital consumer products

1.3 Features

- 8-V to 22-V input
- 1.05-V and 1.8-V output
- Up to 4 A per channel output
- 350-kHz psudeo-fixed frequency D-CAP2 mode control
- Independent enable switches for power-on/power-off testing

2 Electrical Performance Specifications

Table 2-1. TPS53128EVM-620 Electrical and Performance Specifications

Parameter		Notes and Conditions	MIN	TYP	MAX	UNIT
INPUT CHARACTERISTICS						
V_{IN}	Input voltage		8	12	22	V
I_{IN}	Input current	$V_{IN} = 12\text{ V}$, $I_{OUT1} = 4\text{ A}$, $I_{OUT2} = 4\text{ A}$	—	1.2	1.5	A
	No load input current	$V_{IN} = 12\text{ V}$, $I_{OUT} = 0\text{ A}$	—	20	—	mA
V_{IN_UVLO}	Input UVLO	$I_{OUT} = 4\text{ A}$	4.0	4.2	4.5	V
OUTPUT CHARACTERISTICS						
V_{OUT1}	Output voltage 1	$V_{IN} = 12\text{ V}$, $I_{OUT1} = 2\text{ A}$	—	1.05	—	V
	Line regulation	$V_{IN} = 8\text{ V to }22\text{ V}$	—	—	1%	
	Load regulation	$I_{OUT1} = 0\text{ A to }4\text{ A}$	—	—	1%	
V_{OUT1_rip}	Output voltage ripple	$V_{IN} = 12\text{ V}$, $I_{OUT2} = 4\text{ A}$	—	-	30	mVpp
I_{OUT1}	Output current 1	$V_{IN} = 8\text{ V to }22\text{ V}$	0		4	A
V_{OUT2}	Output voltage 2	$V_{IN} = 12\text{ V}$, $I_{OUT2} = 2\text{ A}$	—	1.80	—	V
	Line regulation	$V_{IN} = 8\text{ V to }22\text{ V}$	—	—	1%	
	Load regulation	$I_{OUT2} = 0\text{ A to }4\text{ A}$	—	—	1%	
V_{OUT2_rip}	Output voltage ripple	$V_{IN} = 12\text{ V}$, $I_{OUT2} = 4\text{ A}$	—	—	30	mVpp
I_{OUT2}	Output current 2	$V_{IN} = 8\text{ V to }22\text{ V}$	0		4	A
SYSTEMS CHARACTERISTICS						
F_{SW}	Switching frequency		200	350	400	kHz
η_{pk1}	Peak efficiency of output 1	$V_{IN} = 12\text{ V}$	—	87%	—	
η_1	Full load efficiency of output 1	$V_{IN} = 12\text{ V}$, $I_{OUT1} = 4\text{ A}$	—	85%	—	
η_{pk2}	Peak efficiency of output 2	$V_{IN} = 12\text{ V}$	—	91%	—	
η_2	Full load efficiency of output 2	$V_{IN} = 12\text{ V}$, $I_{OUT2} = 4\text{ A}$	—	90%	—	

3 Schematics

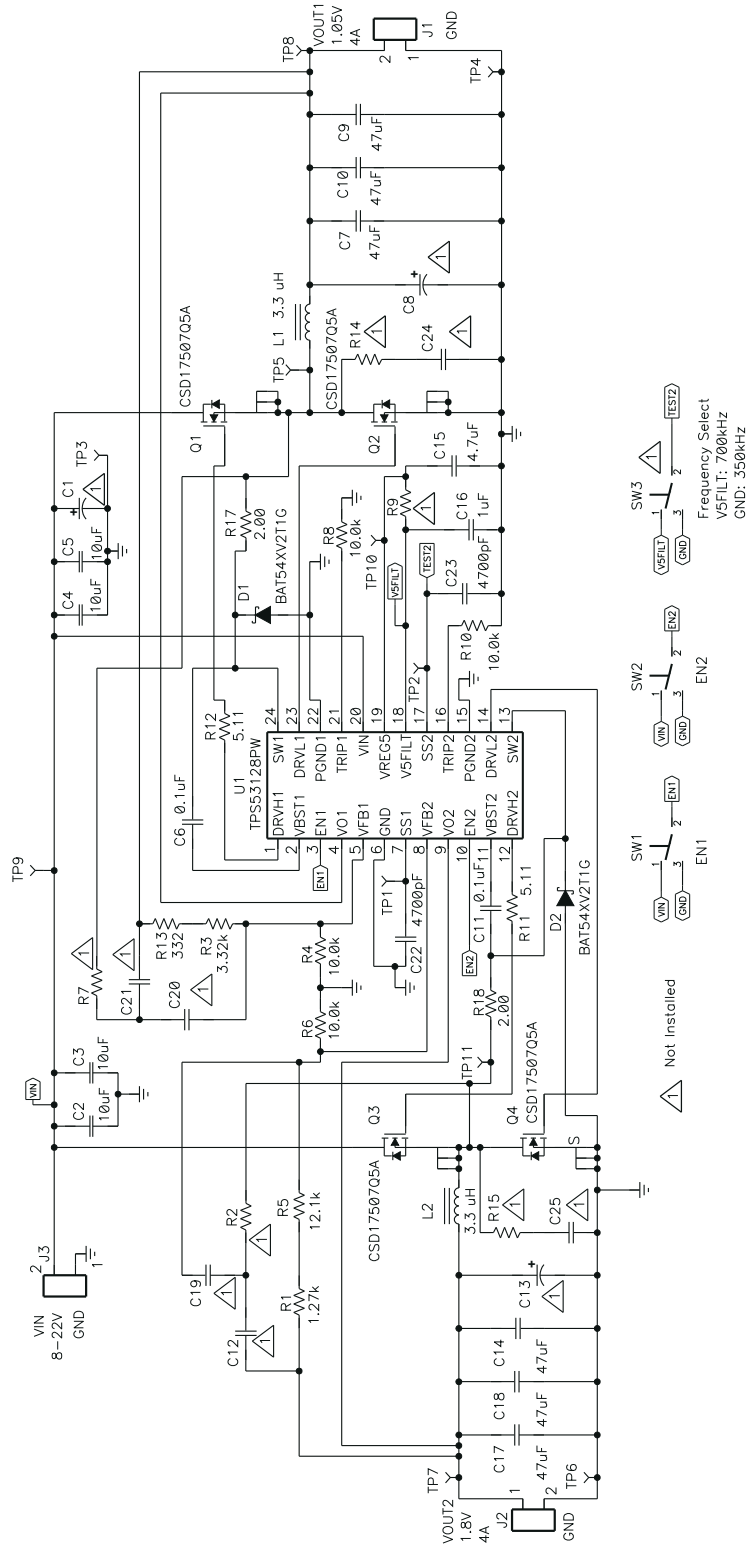

For reference only. See [Table 9-1](#) for specific values.

Figure 3-1. TPS53128EVM-620 Schematic

4 Connector and Test Point Descriptions

4.1 Enable Switches (SW1 and SW2)

The TPS53128EVM-620 includes independent enable switches for each of the two outputs. When the switch is in the DIS position, the channel is disabled and discharged per the internal discharge characteristics of the TPS53128.

To enable V_{OUT1} , place SW1 in the EN position. To enable V_{OUT2} , place SW2 in the EN position.

4.2 Switching Frequency Select Switch (SW3)

The TPS53128EVM-620 does not populate SW3. When using TPS53128EVM-620 to evaluate the TPS53126 controller in the TSSOP package, SW3 can be populated to allow selection of the TPS53126 switching frequency between 350 kHz and 700 kHz.

4.3 Test Point Descriptions

Table 4-1 lists the test points, their labels, uses, and where additional information is located.

Table 4-1. TPS53128EVM-620 Test Points Description

Test Point	Label	Use	Section
TP1	SS1	Monitor Channel 1 Soft-Start Voltage	Section 4.3.4
TP2	SS2	Monitor Channel 2 Soft-Start Voltage	Section 4.3.4
TP3	GND	Ground for Input Voltage	Section 4.3.1
TP4	GND	Ground for Channel 1 Output Voltage	Section 4.3.2
TP5	SW1	Monitor Switching Node for Channel 1	Section 4.3.5
TP6	GND	Ground for Channel 2 Output Voltage	Section 4.3.3
TP7	VOUT2	Monitor Output Voltage for Channel 2	Section 4.3.3
TP8	VOUT1	Monitor Output Voltage for Channel 1	Section 4.3.2
TP9	VIN	Monitor Input Voltage	Section 4.3.1
TP10	VREG5	Monitor Output of VREG5 Regulator	Section 4.3.6
TP11	SW2	Monitor Switching Node for Channel 2	Section 4.3.5

4.3.1 Input Voltage Monitoring (TP3 and TP9)

The TPS53128EVM-620 provides two test points for measuring the voltage applied to the module. This allows the user to measure the actual module voltage without losses from input cables and connectors. Measure all input voltage between TP9 and TP3. To use TP9 and TP3, connect a voltmeter positive terminal to TP9 and negative terminal to TP3.

4.3.2 Channel 1 Output Voltage Monitoring (TP4 and TP8)

The TPS53128EVM-620 provides two test points for measuring the voltage generated at the VOUT1 output by the module. This allows the user to measure the actual output voltage without losses from output cables and connectors. Measure all DC output voltage measurements between TP8 and TP4. To use TP8 and TP4, connect a voltmeter positive terminal to TP8 and negative terminal to TP4.

For output ripple measurements, TP8 and TP4 allow a user to limit the ground loop area by using the tip and barrel measurement technique shown in [Figure 4-1](#).

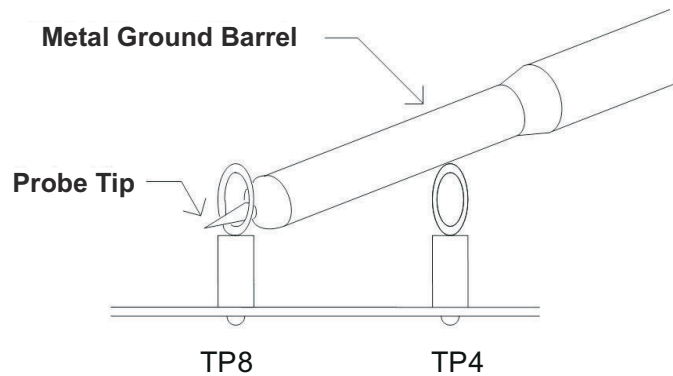

Figure 4-1. Tip and Barrel Measurement for Output Voltage Ripple

4.3.3 Channel 2 Output Voltage Monitoring (TP6 and TP7)

The TPS53128EVM-620 provides two test points for measuring the voltage generated at the V_{OUT2} output by the module. This allows the user to measure the actual output voltage without losses from output cables and connectors. Measure all DC output voltage between TP7 and TP6. To use TP7 and TP6, connect a voltmeter positive terminal to TP7 and negative terminal to TP6.

For output ripple measurements, TP7 and TP6 allow a user to limit the ground loop area by using the tip and barrel measurement technique shown in [Figure 4-1](#).

4.3.4 Soft-Start Voltage Monitoring (TP1, TP2, and TP3)

The TPS53128EVM-620 provides two test points for measuring the soft-start ramp voltages. TP1 monitors the soft-start ramp of Channel 1. TP2 monitors the soft-start ramp of Channel 2. To use TP1 or TP2, connect an oscilloscope probe between TP1 or TP2 and TP3.

4.3.5 Switching Node Monitoring (TP3, TP5, and TP11)

The TPS53128EVM-620 provides two test points for measuring the switching node waveform voltages. TP5 monitors the switching node of Channel 1. TP2 monitors the switching node of Channel 2. To use TP5 or TP11, connect an oscilloscope probe between TP5 or TP11 and TP3.

4.3.6 5-V Regulator Output Monitoring (TP3 and TP10)

The TPS53128EVM-620 provides a test point for measuring the output of the internal 5-V regulator. TP10 monitors the output voltage of the internal 5-V regulator. To use TP10, connect a voltmeter positive terminal to TP10 and negative terminal to TP3.

5 Test Setup

5.1 Equipment

5.1.1 Voltage Source

The input voltage source (V_{IN}) is a 0-V to 25-V variable DC source capable of supplying 3.0 A_{DC} minimum.

5.1.2 Meters

A1: 0 A_{DC} to 5 A_{DC} , ammeter

V1: V_{IN} , 0-V to 25-V voltmeter

V2: V_{OUT1} , 0-V to 2-V voltmeter

V3: V_{OUT2} , 0-V to 2-V voltmeter

5.1.3 Loads

LOAD1 – One output load is an electronic load set for constant current mode capable of 0 A_{DC} to 4 A_{DC} at 1.05 V_{DC} .

LOAD2 – The other output load is an electronic load set for constant current mode capable of 0 A_{DC} to 4 A_{DC} at 1.8 V_{DC} .

5.1.4 Oscilloscope and Probe

The oscilloscope, analog or digital, must be set for AC-coupled measurement with 20-MHz bandwidth limiting. Use 20-mV/division vertical resolution and 1.0- μ s/division horizontal resolution for the output ripple voltage test.

Oscilloscope probes with exposed conductive ground barrels are recommended.

5.1.5 Recommended Wire Gauge

V_{IN} to J3 – The connection between the source voltage V_{IN} and J1 of TPS53128EVM-620 can carry as much as 2 A_{DC} . The minimum recommended wire size is AWG #16 with the total length of wire less than two feet (1-foot input, 1-foot return).

J1 to LOAD1 and J2 to LOAD2 – The connection between J1 and LOAD1 and J2 and LOAD2 of TPS53128EVM-620 can carry as much as 4 A_{DC} each. The minimum recommended wire size is AWG #14 with the total length of wire less than two feet (1-foot input, 1-foot return).

5.1.6 Other Test Equipment

FAN – The TPS53128EVM-620 evaluation module includes components that can get hot to touch. Because this EVM is not enclosed to allow probing of circuit nodes, a small fan capable of 200lfm–400 lfm is recommended to reduce component temperatures when operating.

5.2 Recommended Setup

[Figure 5-1](#) shows the recommended test setup to evaluate the TPS53128EVM-620. Working at an ESD workstation, make sure that any wrist straps, bootstraps, or mats are connected referencing the user to earth ground before power is applied to the EVM. Electrostatic smock and safety glasses also are recommended.

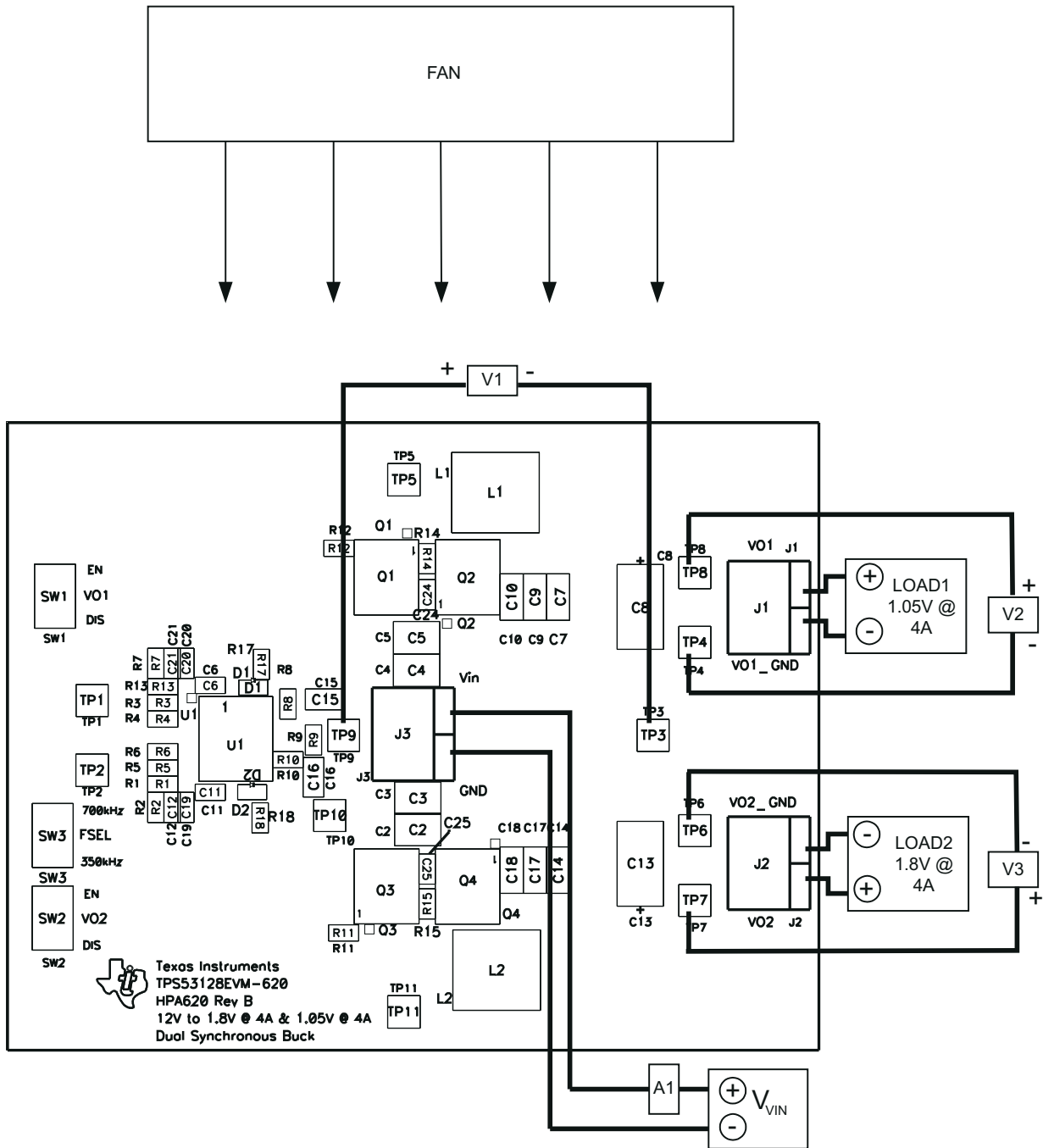

Figure 5-1. TPS53128EVM-620 Recommended Test Setup

6 Test Procedure

6.1 Start-Up Procedure

1. Prior to connecting the DC input source V_{IN} , it is advisable to limit the source current from V_{IN} to 3.0 A_{DC} maximum. Make sure V_{IN} is initially set to 0 V.
2. Ensure LOAD1 and LOAD2 are set to constant current mode to sink 0 A before V_{IN} is applied.
3. Verify SW1 and SW2 are in the desired position.
4. Place a fan as shown in [Figure 5-1](#) and turn it on, making sure air is flowing across the EVM.
5. Increase V_{IN} from 0 V to 12 V_{DC}.

6.2 Line/Load Regulation and Efficiency Measurement Procedure

1. Set up the TPS53128EVM-620 per [Section 5.2](#).
2. Start up the TPS53128EVM-620 per [Section 6.1](#).
3. Adjust V_{IN} to desired value between 8 V_{DC} and 22 V_{DC}.
4. Adjust LOAD1/LOAD2 to desired load between 0 A and 4 A_{DC}.
5. Read input voltage, output voltage, and input current from V1, V2/V3, and A1, respectively.
6. Shut down TPS53128EVM-620 per [Section 6.4](#).

6.3 Output Ripple Voltage Measurement Procedure

1. Set up the TPS53128EVM-620 per [Section 5.2](#).
2. Start up the TPS53128EVM-620 per [Section 6.1](#).
3. Adjust V_{IN} to desired value between 8 V_{DC} and 22 V_{DC}.
4. Adjust LOAD1/LOAD2 to desired load between 0 A and 4 A_{DC}.
5. Connect the oscilloscope probe to TP8 and TP4 for V_{OUT1} , or TP7 and TP6 for V_{OUT2} as shown in [Figure 4-1](#).
6. Measure output ripple.
7. Shut down the TPS53128EVM-620 per [Section 6.4](#).

6.4 Shutdown Procedure

1. Set SW1 to DIS.
2. Set SW2 to DIS.
3. Decrease LOAD1 to 0 A and shut down LOAD1.
4. Decrease LOAD2 to 0 A and shut down LOAD2.
5. Decrease V_{IN} to 0 V and shut down V_{IN} .
6. Shut down the fan.

7 Performance Data and Typical Characteristic Curves

Figure 7-1 through Figure 7-8 present typical performance curves for the TPS53128EVM-620. Because actual performance data can be affected by measurement techniques and environmental variables, these curves are presented for reference and may differ from actual field measurements.

7.1 Efficiency

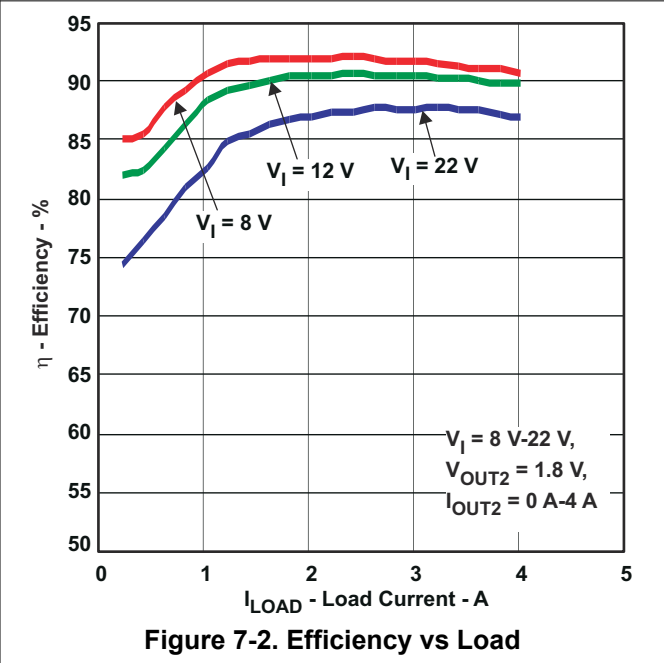
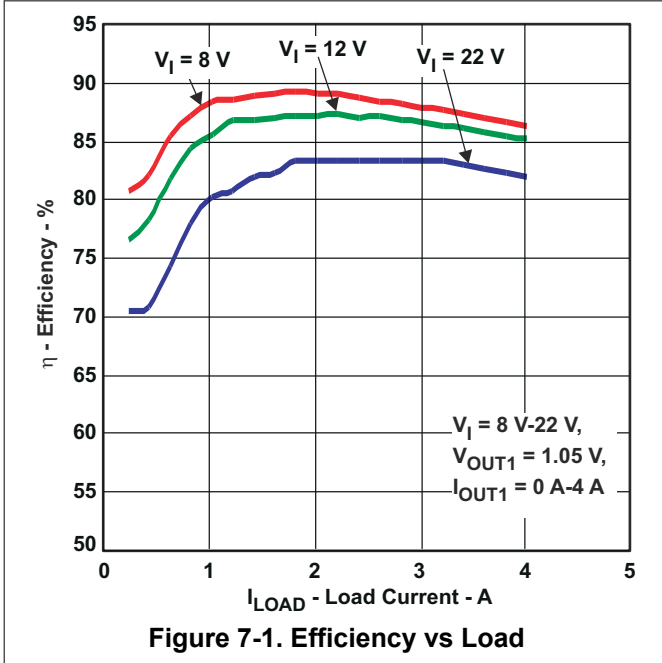

7.2 Line and Load Regulation

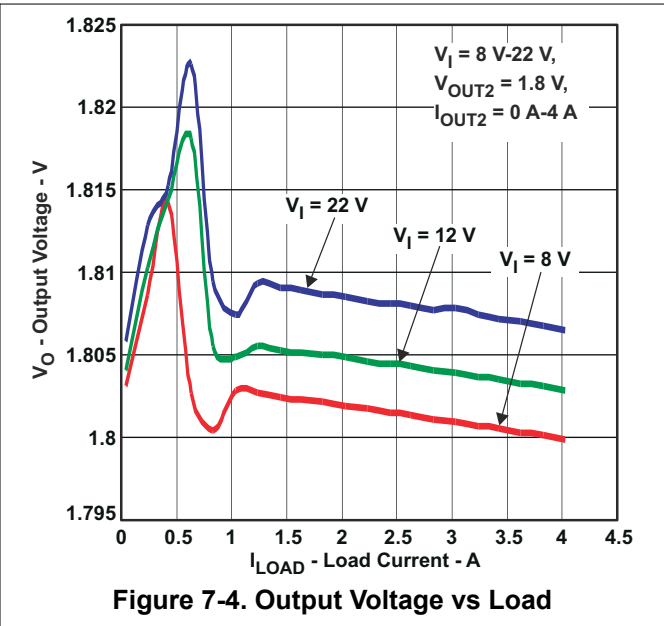
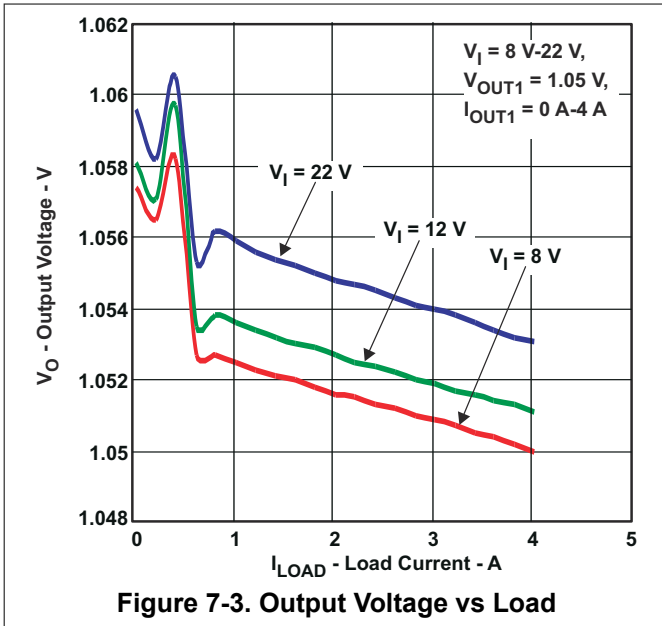

7.3 Output Voltage Ripple

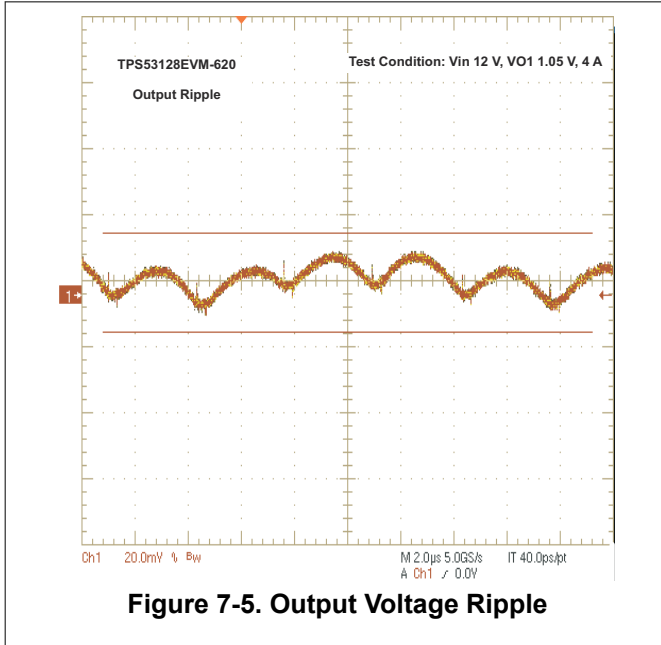

Figure 7-5. Output Voltage Ripple

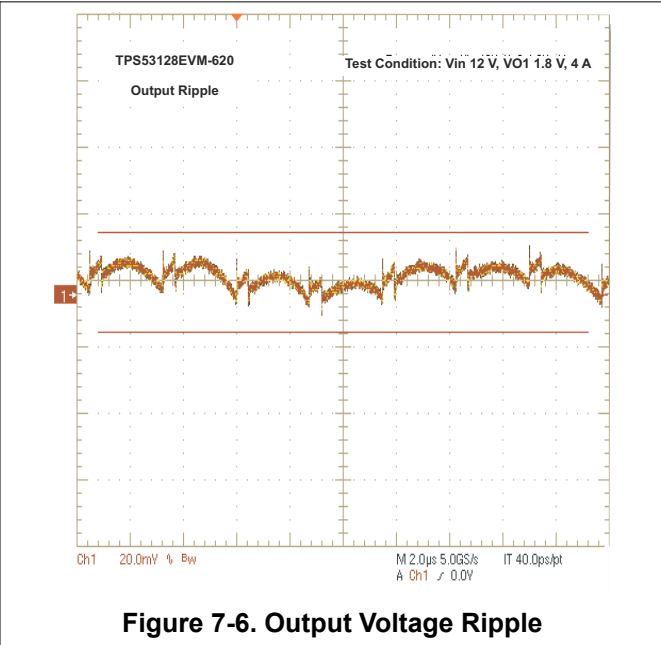

Figure 7-6. Output Voltage Ripple

7.4 Switch Node Waveforms

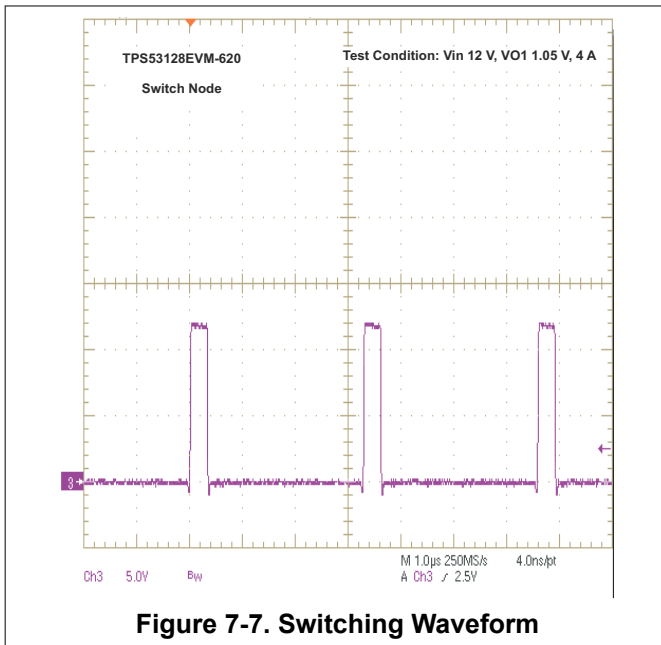

Figure 7-7. Switching Waveform

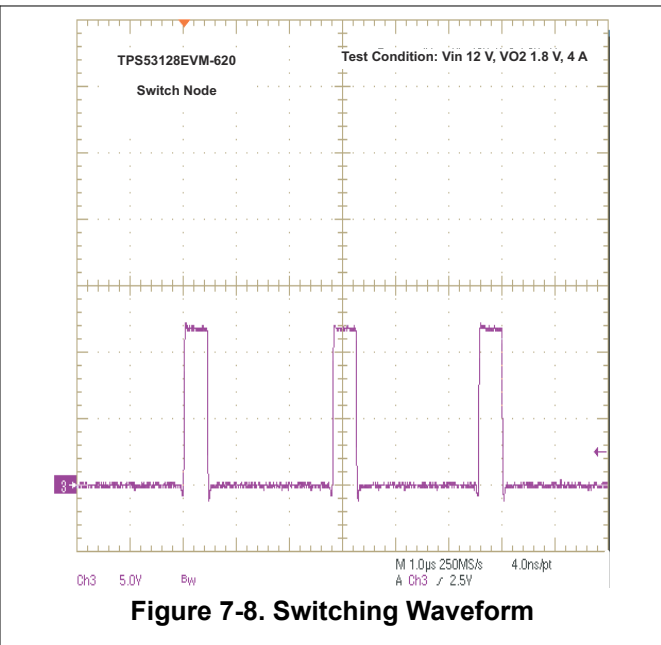

Figure 7-8. Switching Waveform

8 EVM Assembly Drawings and Layout

Figure 8-1 through Figure 8-6 show the design of the TPS53128EVM-620 printed circuit board. The EVM has been designed using a 4-layer, 2-oz copper-clad circuit board of 3.5 inch by 2.7 inch to allow the user to easily view, probe, and evaluate the TPS53128 control IC in a practical application. Moving components to both sides of the PCB or using additional internal layers can offer additional size reduction for space constrained systems.

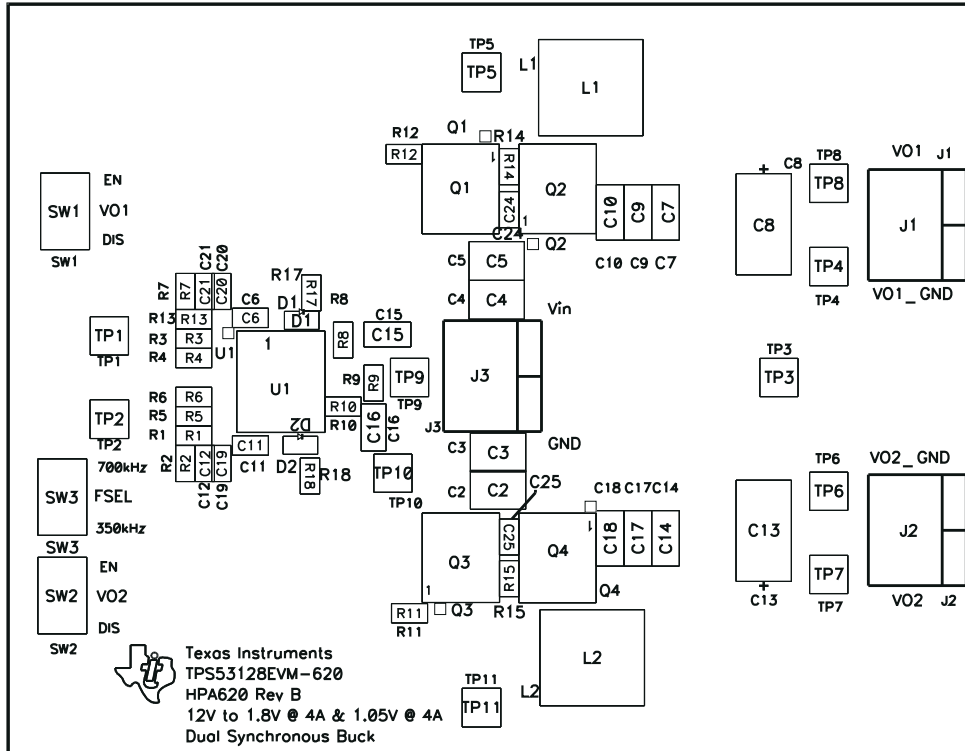

Figure 8-1. Top Assembly

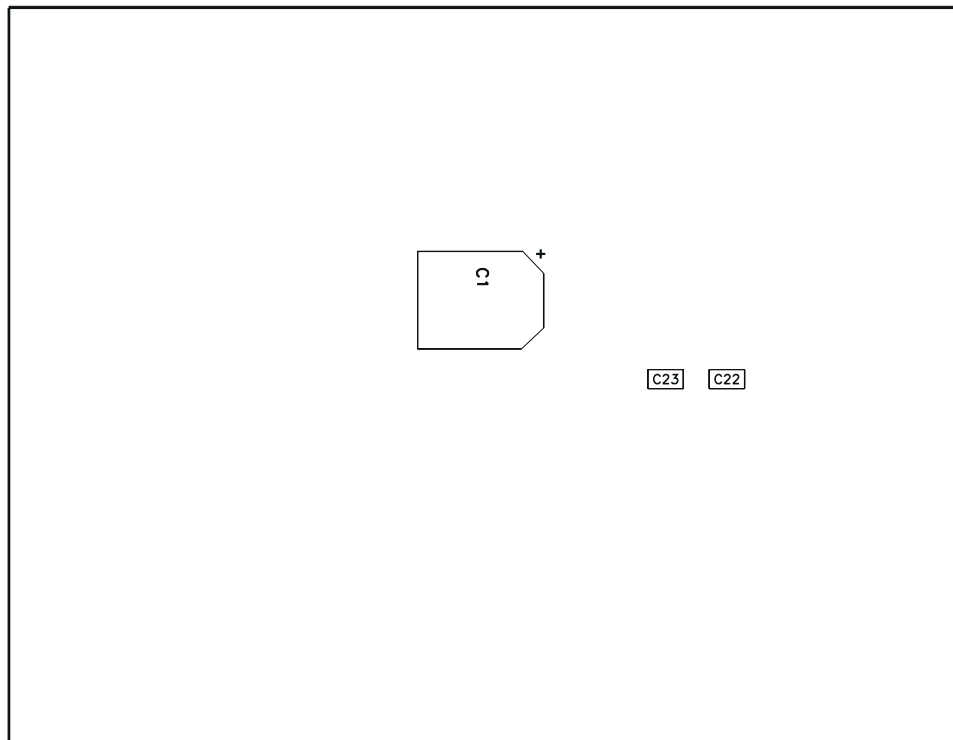

Figure 8-2. Bottom Assembly

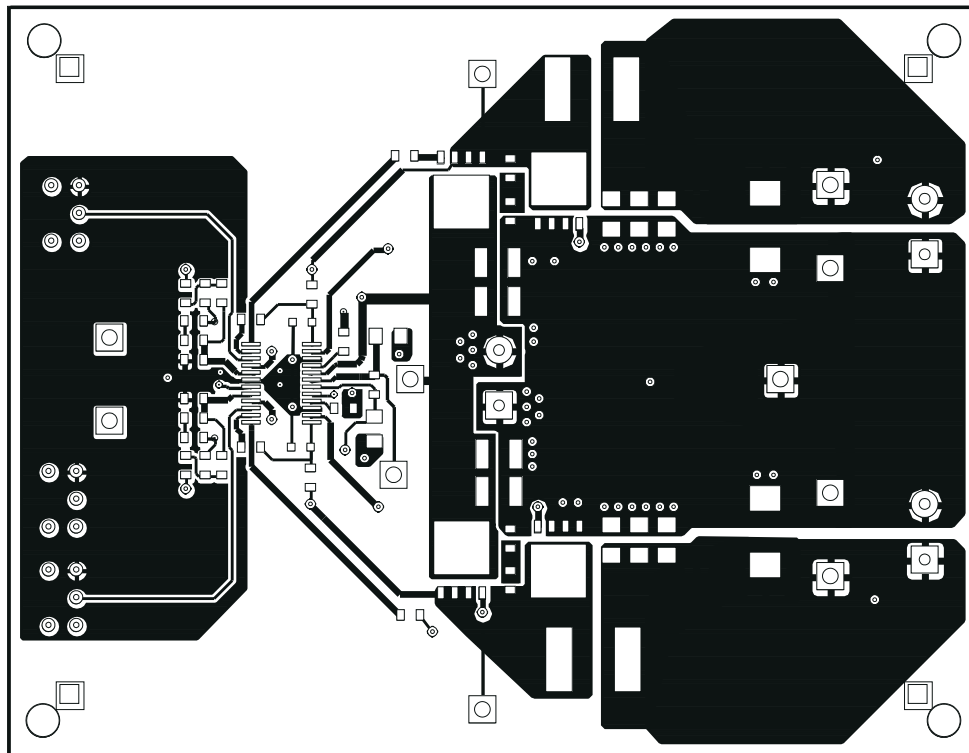

Figure 8-3. Top Layer

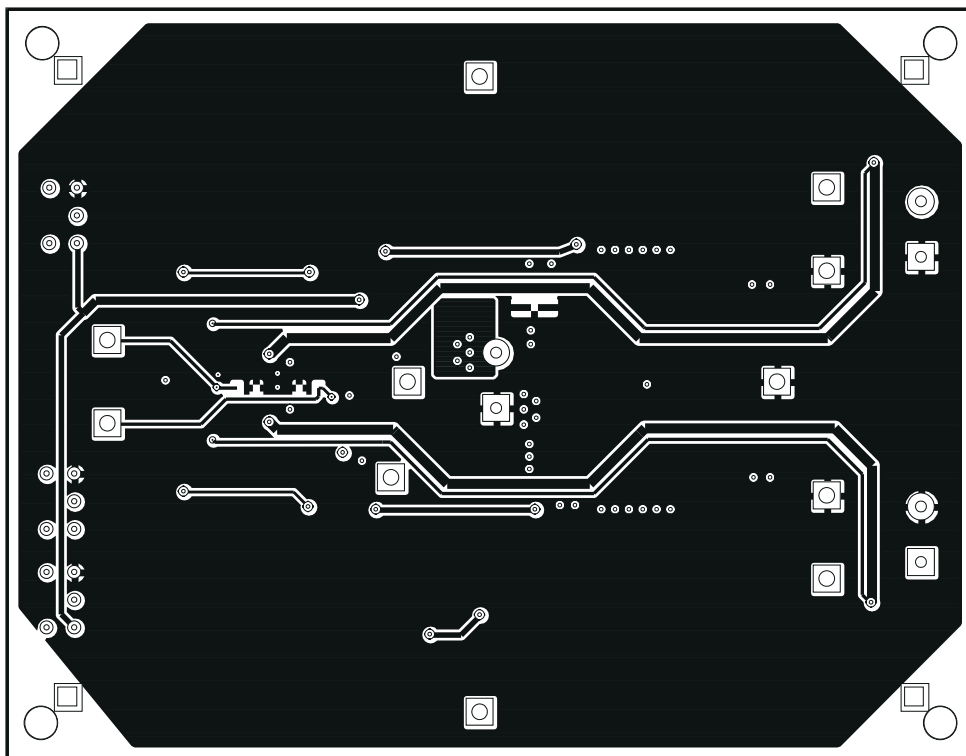

Figure 8-4. Bottom Layer

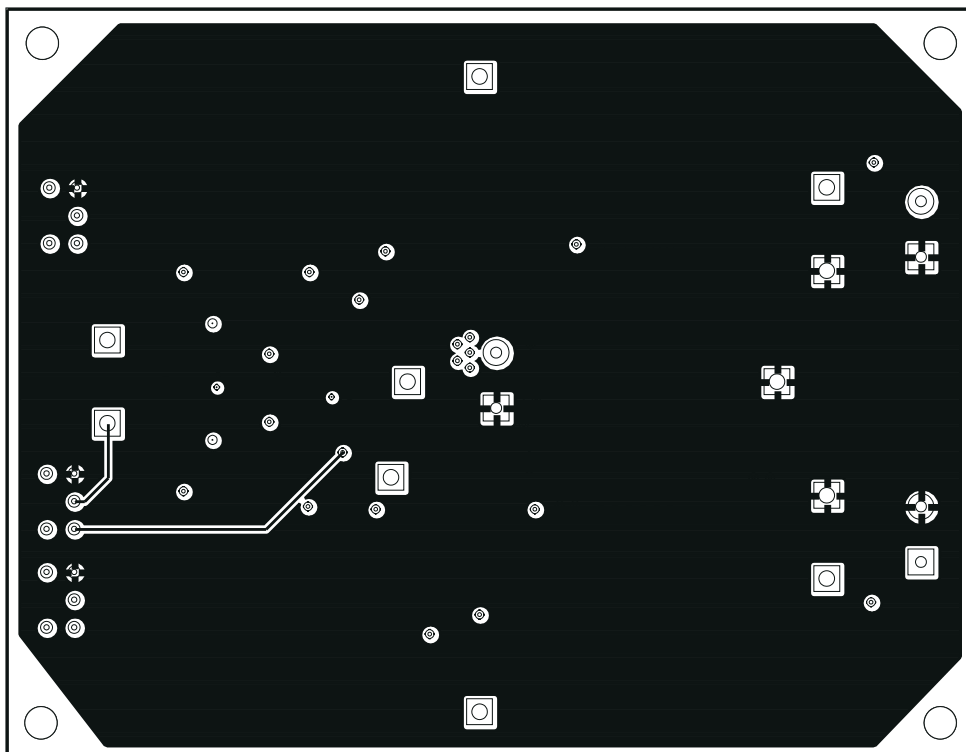

Figure 8-5. Internal Layer 1

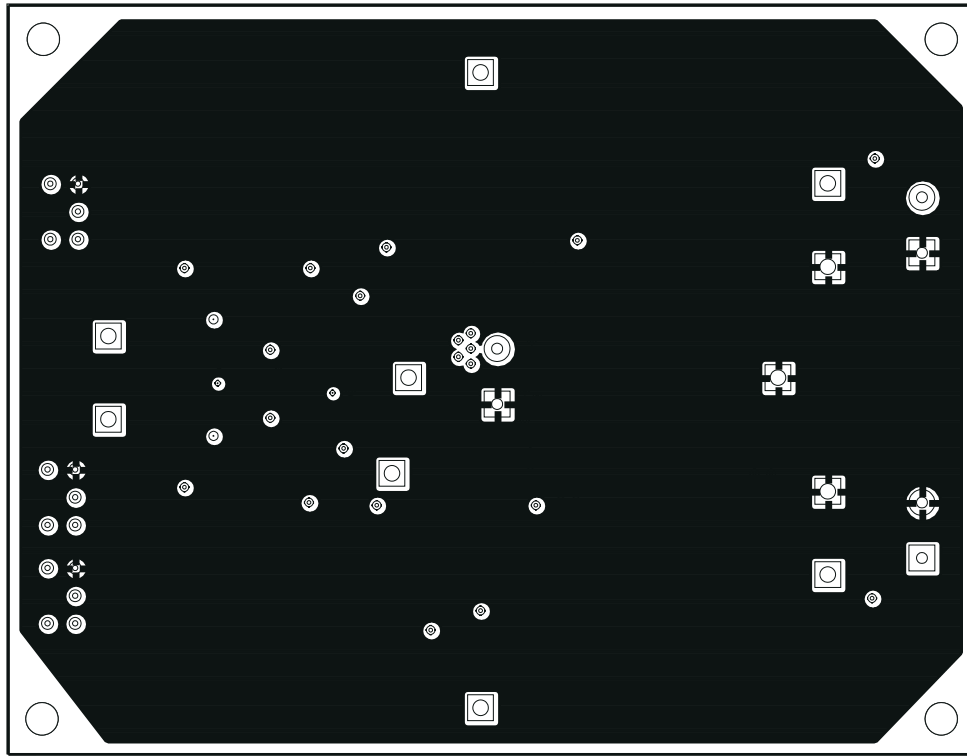

Figure 8-6. Internal Layer 2

9 Bill of Materials

Table 9-1 contains the bill of materials for TPS53128EVM-620. The reference designators reference the schematic in Figure 3-1 and assembly locations in Figure 8-1 and Figure 8-2. Components with a quantity of 0 listed are not populated on the PCB but are provided for reference.

Table 9-1. TPS53128EVM-620 Bill of Materials

Qty	RefDes	Value	Description	Size	Part Number	MFR
0	C1		Capacitor, Aluminum, 25 V, 20%	0.328 × 0.390 inch	Std	Std
0	C12, C19, C20, C21		Capacitor, Ceramic	0603	Std	Std
1	C15	4.7 μF	Capacitor, Ceramic, 10 V, X5R, 20%	0805	Std	Std
1	C16	1 μF	Capacitor, Ceramic, 16 V, X5R, 20%	0805	Std	Std
4	C2, C3, C4, C5	10 μF	Capacitor, Ceramic, 25 V, X5R, 20%	1210	Std	Std
2	C22, C23	4700 pF	Capacitor, Ceramic, Low Inductance, 16 V, X7R, 20%	0603	Std	Std
0	C24, C25		Capacitor, Ceramic, 25 V, X7R, 20%	0603	Std	Std
2	C6, C11	0.1 μF	Capacitor, Ceramic, 50 V, X5R, 10%	0603	Std	Std
6	C7, C9, C10, C14, C17, C18	47 μF	Capacitor, Ceramic, 6.3 V, X5R, 20%	1206	Std	Std
0	C8, C13	330 μF	Capacitor, PXE, 4.0 V, 15 mΩ, 20%	7343 (D)	APXE4R0ARA331MF61G	NIPPON CHEMI-CON
2	D1, D2	BAT54XV2T1G	Diode, Schottky, 200 mA, 30 V	SOD523	BAT54XV2T1G	On Semi
3	J1, J2, J3	ED120/2DS	Terminal Block, 2-pin, 15-A, 5.1 mm	0.40 × 0.35 inch	ED120/2DS	OST
2	L1, L2	3.3 μH	Inductor, SMT Chip Coil, ±30%	8 × 8 mm	LQH88PN3R3N38	Murata
4	Q1, Q2, Q3, Q4	CSD17507Q5A	MOSFET, N-Chan, 30 V, 65 A, 11.8 mΩ	QFN-8 POWER	CSD17507Q5A	TI
1	R1	1.27 k	Resistor, Chip, 1/16W, 1%	0603	Std	Std
4	R10, R4, R6, R8	10.0 k	Resistor, Chip, 1/16W, 1%	0603	Std	Std
2	R11, R12	5.11	Resistor, Chip, 1/16W, 1%	0603	Std	Std
1	R13	332	Resistor, Chip, 1/16W, 1%	0603	Std	Std
0	R14, R15		Resistor, Chip, 1/8W, 5%	0603	Std	Std
2	R17, R18	2.00	Resistor, Chip, 1/16W, 1%	0603	Std	Std
0	R2, R7, R9		Resistor, Chip, 1/16W, 1%	0603	Std	Std
1	R3	3.32 k	Resistor, Chip, 1/16W, 1%	0603	Std	Std
1	R5	12.1 k	Resistor, Chip, 1/16W, 1%	0603	Std	Std
2	SW1, SW2	G12AP-RO	Switch, ON-ON Mini Toggle	0.28 × 0.18 inch	G12AP-RO	Nikkai
0	SW3	G12AP-RO	Switch, ON-ON Mini Toggle	0.28 × 0.18 inch	G12AP-RO	Nikkai
4	TP1, TP2, TP5, TP11	5012	Test Point, White, Thru Hole	0.125 × 0.125 inch	5012	Keystone
1	TP10	5013	Test Point, Orange, Thru Hole	0.125 × 0.125 inch	5013	Keystone
3	TP3, TP4, TP6	5011	Test Point, Black, Thru Hole	0.125 × 0.125 inch	5011	Keystone
2	TP7, TP8	5014	Test Point, Yellow, Thru Hole	0.125 × 0.125 inch	5014	Keystone
1	TP9	5010	Test Point, Red, Thru Hole	0.125 × 0.125 inch	5010	Keystone
1	U1	TPS53128PW	IC, Dual Synchronous Step-Down Controller For Low-Voltage Power Rails	TSSOP	TPS53128PW	TI
1	—		PCB, 2.70 inch × 3.50 inch × 0.063 inch FR-4	2.7 inch × 3.5 inch	HPA620	Any

10 Revision History

NOTE: Page numbers for previous revisions may differ from page numbers in the current version.

Changes from Revision * (February 2011) to Revision A (January 2022)	Page
• Updated the numbering format for tables, figures, and cross-references throughout the document.	3
• Updated the user's guide title.....	3

IMPORTANT NOTICE AND DISCLAIMER

TI PROVIDES TECHNICAL AND RELIABILITY DATA (INCLUDING DATA SHEETS), DESIGN RESOURCES (INCLUDING REFERENCE DESIGNS), APPLICATION OR OTHER DESIGN ADVICE, WEB TOOLS, SAFETY INFORMATION, AND OTHER RESOURCES "AS IS" AND WITH ALL FAULTS, AND DISCLAIMS ALL WARRANTIES, EXPRESS AND IMPLIED, INCLUDING WITHOUT LIMITATION ANY IMPLIED WARRANTIES OF MERCHANTABILITY, FITNESS FOR A PARTICULAR PURPOSE OR NON-INFRINGEMENT OF THIRD PARTY INTELLECTUAL PROPERTY RIGHTS.

These resources are intended for skilled developers designing with TI products. You are solely responsible for (1) selecting the appropriate TI products for your application, (2) designing, validating and testing your application, and (3) ensuring your application meets applicable standards, and any other safety, security, regulatory or other requirements.

These resources are subject to change without notice. TI grants you permission to use these resources only for development of an application that uses the TI products described in the resource. Other reproduction and display of these resources is prohibited. No license is granted to any other TI intellectual property right or to any third party intellectual property right. TI disclaims responsibility for, and you will fully indemnify TI and its representatives against, any claims, damages, costs, losses, and liabilities arising out of your use of these resources.

TI's products are provided subject to [TI's Terms of Sale](#) or other applicable terms available either on ti.com or provided in conjunction with such TI products. TI's provision of these resources does not expand or otherwise alter TI's applicable warranties or warranty disclaimers for TI products.

TI objects to and rejects any additional or different terms you may have proposed.

Mailing Address: Texas Instruments, Post Office Box 655303, Dallas, Texas 75265
Copyright © 2022, Texas Instruments Incorporated