

AN-1948 LMV1090 Noise Suppression Microphone Amplifier Evaluation Kit

1 Overview

The LMV1090TL evaluation kit contains the following:

- LMV1090TL Demonstration Board, 551600317–001
- Mini USB Board, 551600192–002
- Control Software
- Microphone board
- Microphone cable
- I²C cable

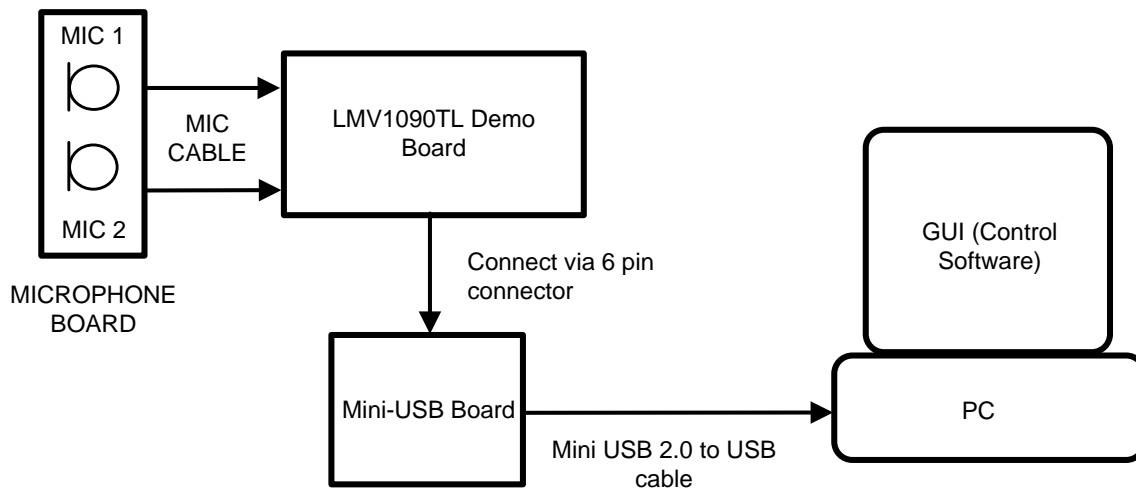

Figure 1. Basic Evaluation System

2 Introduction

The LMV1090 demo board ([Figure 2](#)) offers the means for easy evaluation of the LMV1090 Dual input, Far Field Noise Suppression (FFNS) Microphone Amplifier with Differential Outputs. This board has the LMV1090TL mounted on the PCB together with surrounding components ready for evaluation. This board offers interfaces for connecting two microphones and an I²C interface for controlling the settings of the LMV1090.

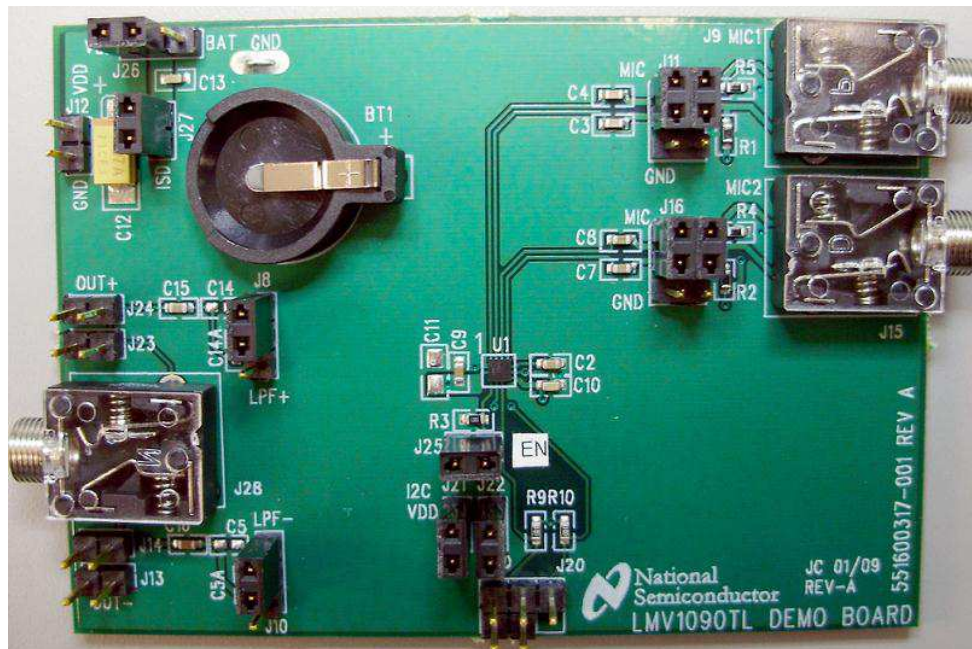

Figure 2. LMV1090TL Demo Board

3 General Description

The LMV1090 is a fully analog dual input, differential output, microphone array amplifier designed to reduce background acoustic noise, while delivering superb speech clarity in voice communications applications. The LMV1090 has two differential input microphone amplifier channels plus far-field noise suppression (FFNS) circuitry. The LMV1090 preserves near-field wire signals within 4cm of the microphones. While rejecting far-field acoustic noise greater than 50cm from the microphones. Up to 20dB of far-field rejection is possible in a properly configured and using ± 0.5 dB matched microphones.

4 Operating Conditions

- Temperature Range $-40^{\circ}\text{C} \leq T_A \leq 85^{\circ}\text{C}$
- Power Supply Voltage $2.7\text{V} \leq V_{\text{DD}} \leq 5.5\text{V}$
- I²C supply voltage $1.7\text{V} \leq I^2\text{CV}_{\text{DD}} \leq 5.5\text{V}$

5 LMV1090 Demo Board

The LMV1090TL Demonstration Board takes analog inputs from two microphones and performs the Far Field noise cancellation process. It outputs an analog differential signal. This output can be connected to a recording device, such as a personal computer sound card through its LINE IN/MIC IN input or mobile phone through its MIC IN input, for evaluation purposes.

The LMV1090TL contains programmable pre and post gain amplifiers, which can be adjusted through I²C commands and the software GUI. See [Section 8](#).

The LMV1090TL has four operating modes:

- Noise cancellation
- Mic1 enabled
- Mic2 enabled
- Mic1 + Mic2

The operating modes can all be controlled through I²C commands and the software GUI. See [Section 8](#).

6 Power Supply of the LMV1090 Demo Board

The LMV1090 demo board provides three possible sources for the power supply:

- Using the external supply via header J12 for V_{DD} and GND. I^2CV_{DD} pin can get its supply from the V_{DD} pin by placing a jumper across J21 and J22. See [Figure 3](#).
- Using a small battery placed in battery holder mounted on the PCB. See [Figure 4](#). For a limited time, the demo board can be operated from the board battery (CR1220 placed in the battery holder BT1). To operate the board using a battery, the following jumpers: J26, J21, and J22 must be configured as shown in [Figure 4](#).
- Via the I²C interface header J20. See [Figure 5](#). This is the default configuration of the LMV1090TL demonstration board when received by customer. Using this configuration and a mini USB board eliminates the need for a separate power supply for evaluation. Supplying the demo board is possible by generating jumpers on headers J21 and J22.

6.1 Enable Pin

The enable pin must be logic high for operating the on board LMV1090. This is done by placing a jumper on header J25 (see [Figure 5](#)).

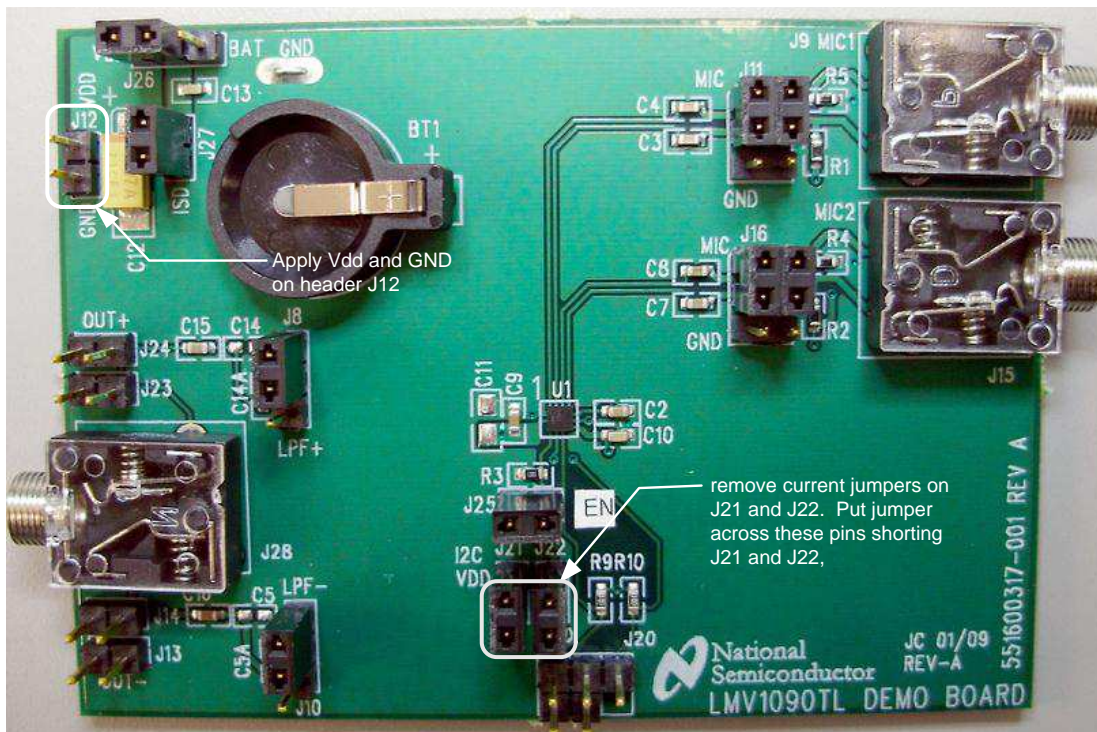

Figure 3. Power Supply Connectors and Headers

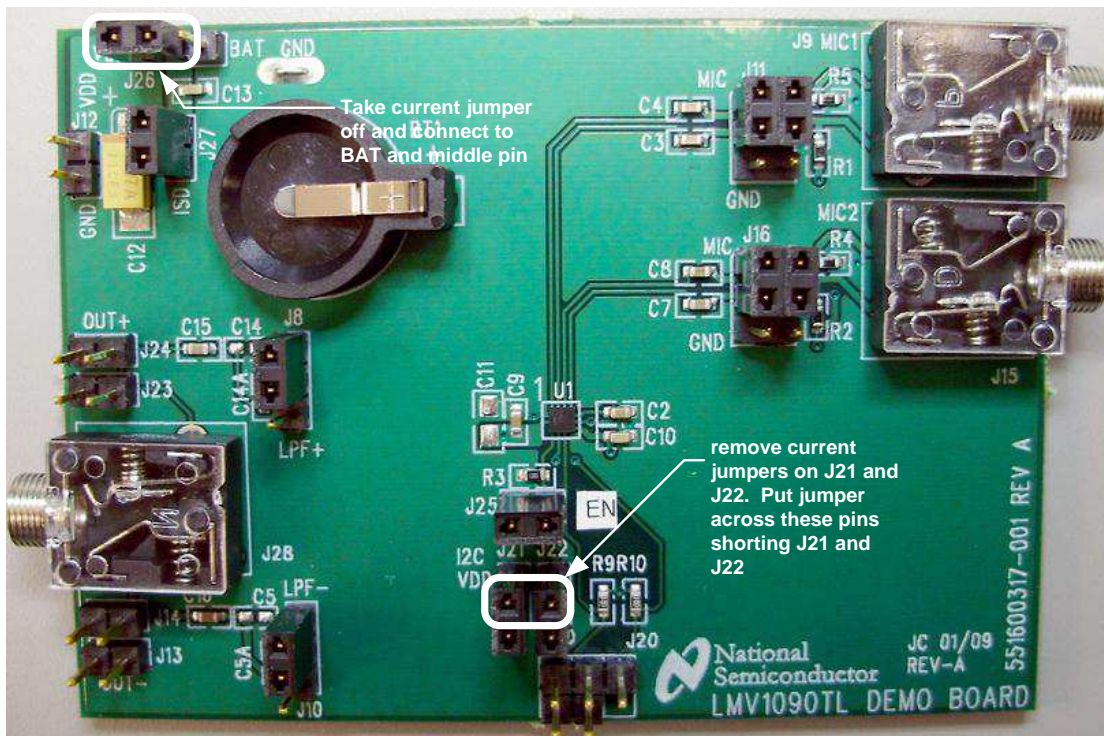

Figure 4. Battery Power Supply

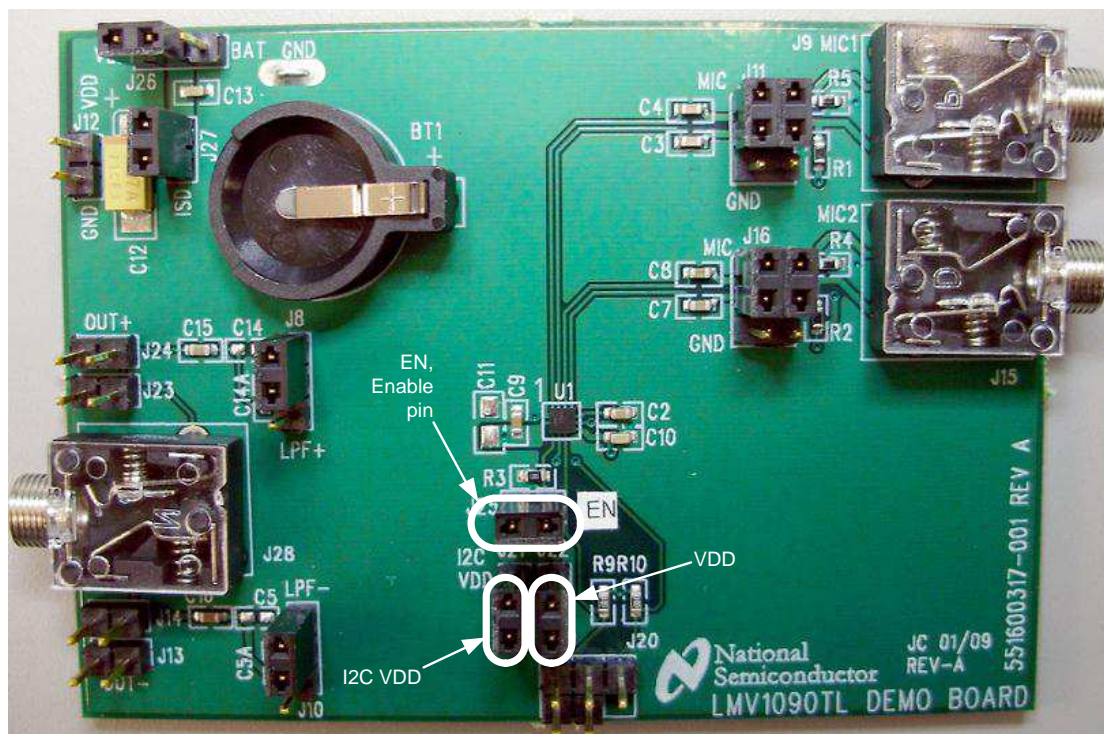

Figure 5. I²C Power Supply

7 The On Board I²C Compatible Interface

The I²C Compatible Interface that is available on the LMV1090 demo board is located at the header J20 (see [Figure 6](#)). The signals on this header are described in [Table 1](#).

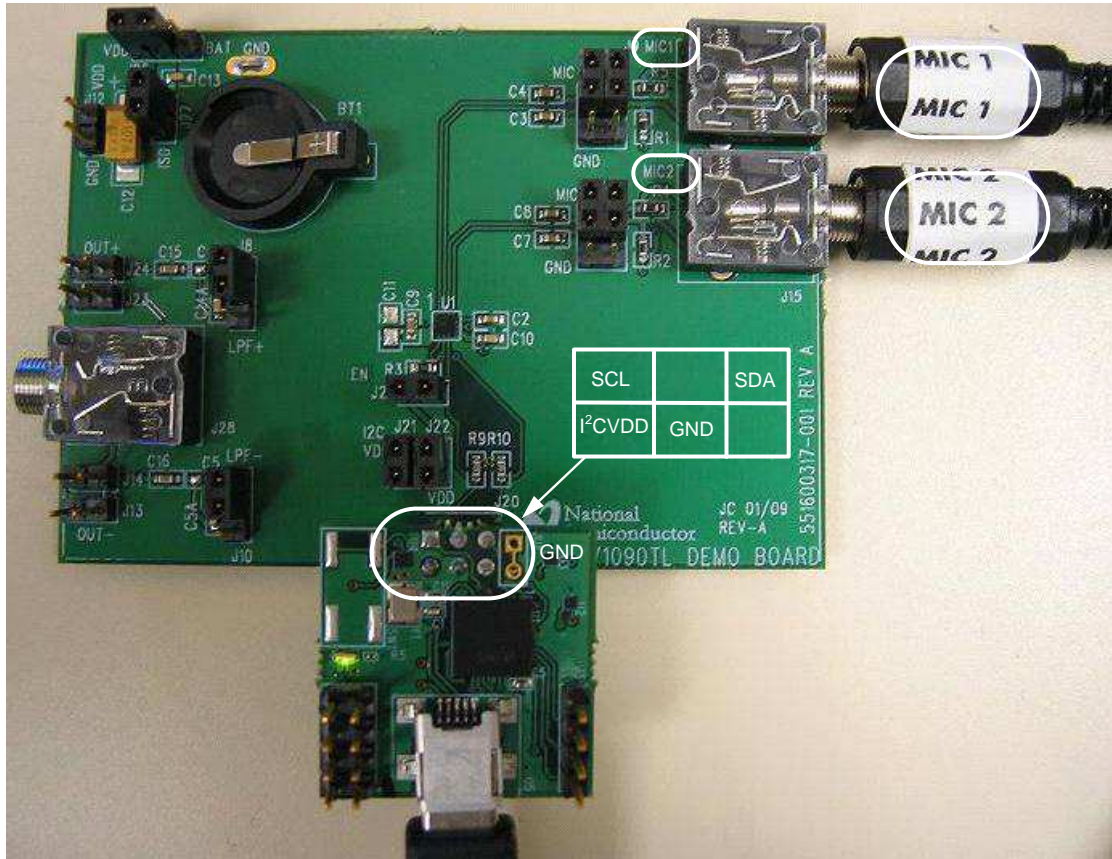

Figure 6. Demo Board I²C Mic Inputs

Table 1. I²C Connector

PIN	Function
1	SCL
2	I ² CVDD
3	NC
4	GND
5	SDA
6	NC

The SCL pin and the SDA pin both have a 10kΩ pull-up resistor to I²CV_{DD} mounted on the PCB.

[Figure 6](#) shows how the mini USB board should be connected to the LMV1090TL demo board. Note the USB cable should be connected away from the board. The supply voltage for the I²C interface of the LMV1090 can be selected with the jumper J22. To avoid possible damages to the LMV1090 part, the I²CV_{DD} voltage should not exceed the V_{DD} voltage.

8 LMV1090 Control Demo Software

Together with the LMV1090 demo board, there is a software package available that can assist in evaluation, programming, and testing of the LMV1090 chip via the I²C Interface. This software is operated via the graphical user interface as shown in [Figure 7](#). This software provides two groups of functions.

There are four buttons in the top of the screen that allows the following:

- Enable and Disable the microphone amplifiers
- Muting the microphone input amplifier
- Default button for resetting part on the left side of the screen is the mode

The 4 buttons on the side select the 4 modes: Noise Cancellation Mode, Only MIC 1 On, Only MIC 2 On, and MIC 1 + MIC 2.

On the right side of the screen are 2 slide bars that control the preamplifier and postamplifier gains.

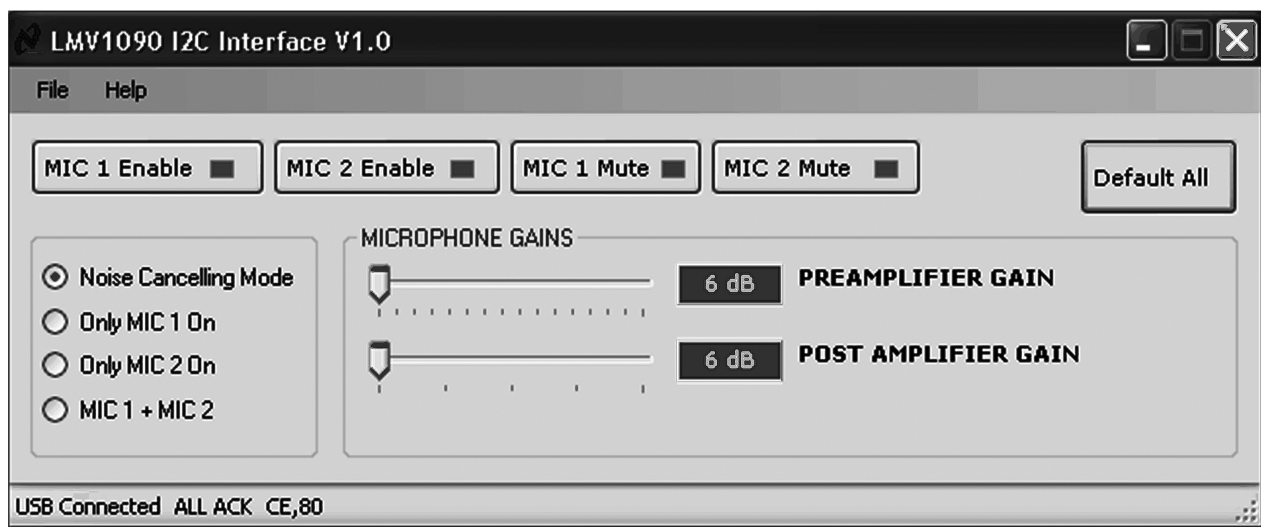

Figure 7. Control Demo Software GUI

9 Connecting Microphones to the LMV1090 Demo Board

The demo board can be used to connect a set of two microphones to the LMV1090 to evaluate the performance of the LMV1090 in a customer application. To enable these microphone input connectors, the jumpers on header J11 and J16 (see [Figure 9](#)) must be placed between pin 3–5 and pin 4–6 of both headers. Microphones can also be connected to 3.5mm connectors J9 and J15 (see [Figure 6](#)).

For an optimal performance of the Far Field Noise Reduction system it is important to find the correct placement of the microphones. In many applications the microphones are placed next to each other with a distance of 1.5cm to 2.5cm between the microphones. The best noise cancelling performance will occur in systems where the far field signals comes from a source orthogonal to the plane of the microphones and where the desired signal is close to the microphones and is located in line with the microphones as shown in [Figure 8](#).

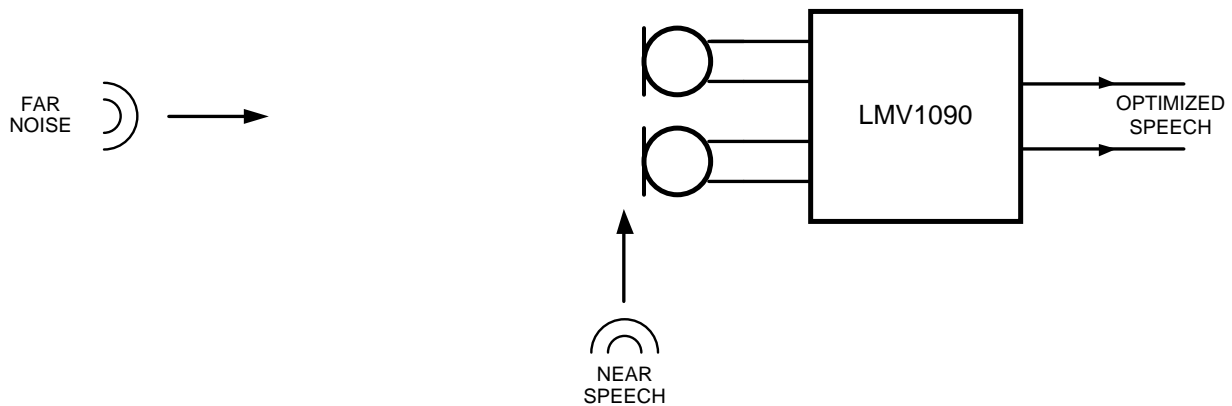

Figure 8. Orientation of Microphones and Sound Sources

10 Microphone Placement in the Application

Because the LMV1090 is a microphone array Far Field Noise Reduction solution, proper microphone placement is critical for optimum performance. Two things need to be considered: The spacing between the two microphones and the position of the two microphones relative to near field source.

If the spacing between the two microphones is too small, near field speech will be canceled along with the far field noise. Conversely, if the spacing between the two microphones is large, the far field noise reduction performance will be degraded. The optimum spacing between Mic 1 and Mic 2 is 1.5-2.5cm. This range provides a balance of minimal near field speech loss and maximum far field noise reduction. The microphones should be in line with the desired sound source 'near speech' and configured in an endfire array orientation from the sound source (see Figure 9). If the 'near speech' (desired sound source) is equidistant to the source like a broadside array (see Figure 10) the result will be a great deal of near field speech loss.

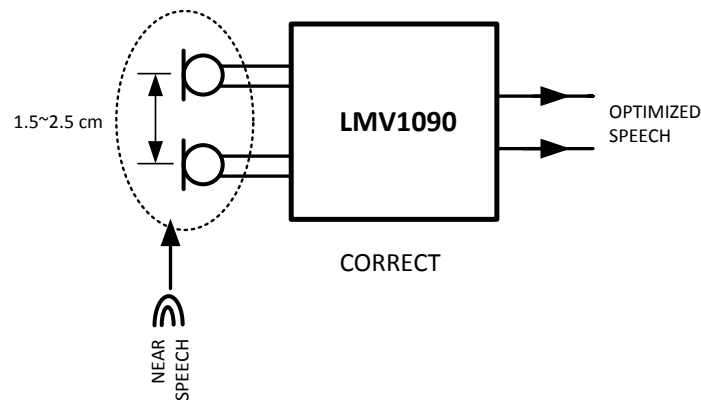

Figure 9. Endfire Array (Correct)

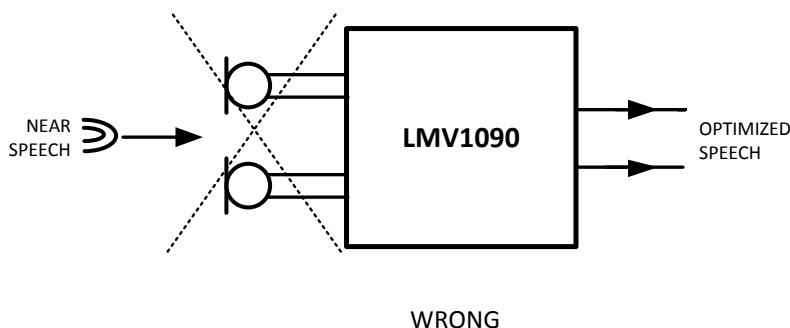

Figure 10. Broadside Array (Incorrect)

11 PCB Layout Guidelines

This section provides general practical guidelines for PCB layouts that use various power and ground traces. Designers should note that these are only "rule-of-thumb" recommendations and the actual results are predicated on the final layout.

11.1 Differential Signals

Keep both signals coupled by routing them closely together and keeping them of equal length. Keep all impedances in both traces of the signal equal.

11.2 Power and Ground

Connect all ground pins together under the part forming a star point. Keep the current for the de-coupling capacitor of the REF pin B4 and the accompanying ground pin B1 separated from the other currents. Keep the location of the supply de-coupling capacitor close to V_{DD} pin C1 and ground.

12 Description of Headers and Connectors of the LMV1090 Demo Board

The LMV1090 demo board provides many headers and connectors for connecting test equipment and controlling the settings of the part, see [Table 2](#). The function that is controlled by the jumpers on the LMV1090 demo board is also indicated on the PCB in silk screen as shown in [Figure 11](#) (The name in parenthesis is as shown in the silk screen).

Table 2. Connector and Header Functions

Designator	Function or Use	Comment
J12	Power supply connector for external supply	
J26	Supply select pin external (V_{DD}) or battery (BAT)	
J11, J16	Connection for input of electrical test signals at pin 4+5	Pin 3+4 differential input with ground at Pin 5+6
J8, J10	Low pass filter selection (LPF+, LPF-)	Pin 1+2 to connect to an external LPF capacitor. Pin 2+3 select the on board LPF capacitor C5, C14 (a minimum of 1nF is always mounted on the board)
J25	Enable pin	
J21	I ² C V_{DD} connect to I ² C interface	
J22	V_{DD} connect to I ² C interface	
J25	Enable pin	
J26	Supply select pin external (V_{DD}) or battery (BAT)	
J27	Connects Supply to V_{DD} pin	

13 Schematic

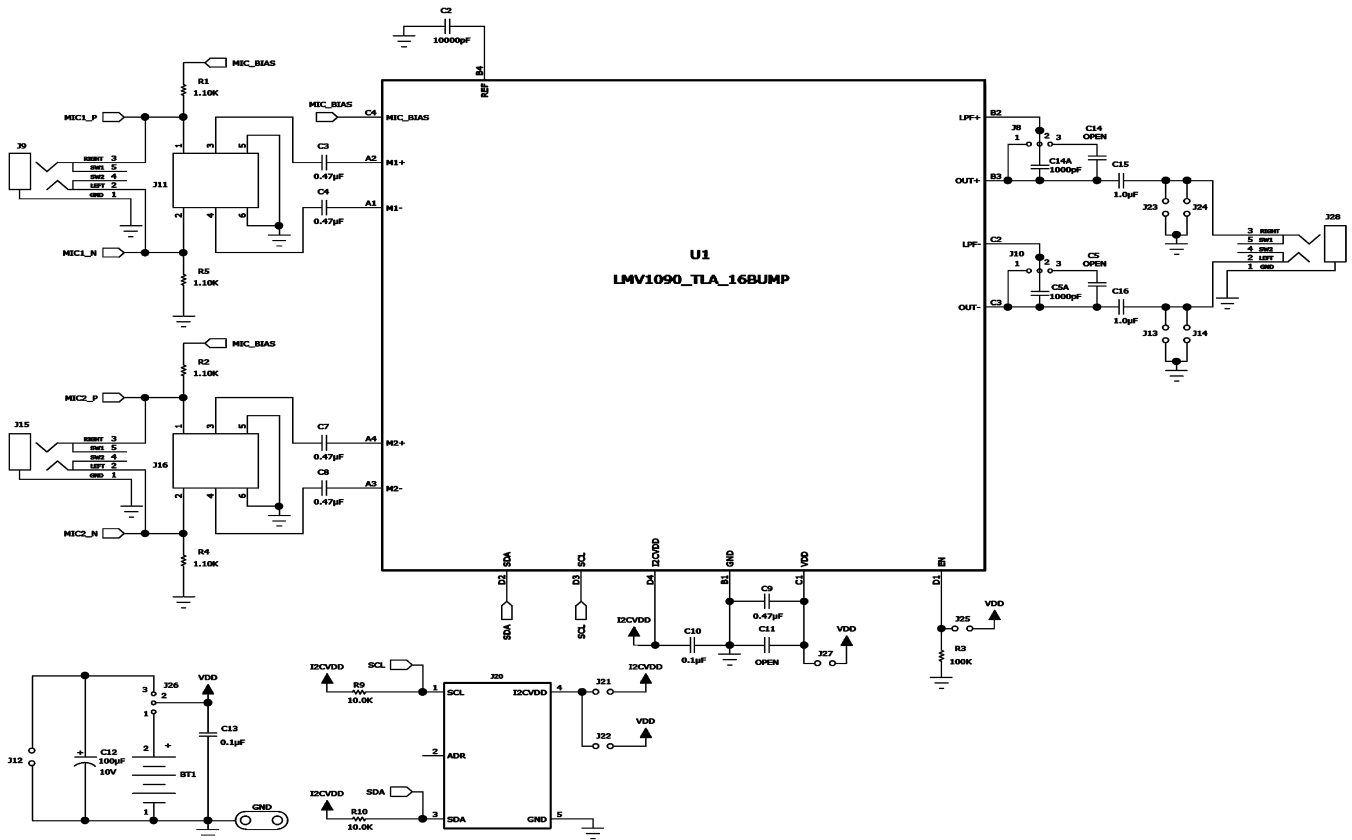

14 Layout

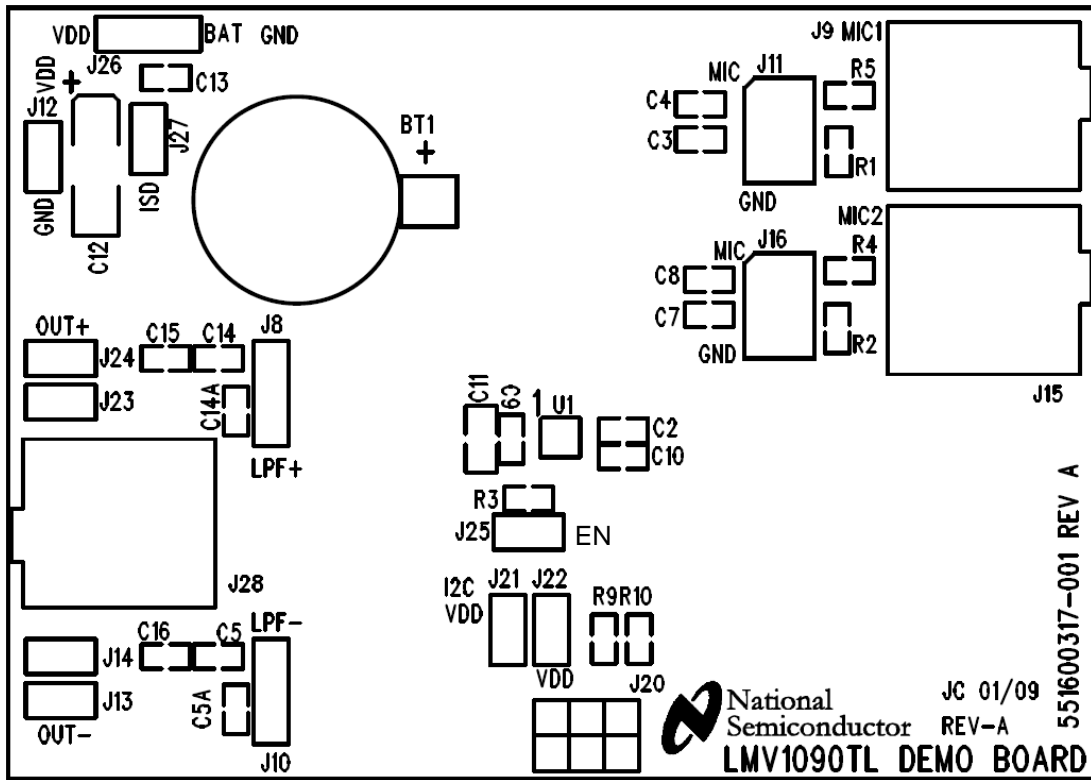

Figure 11. Layout, Silk Screen

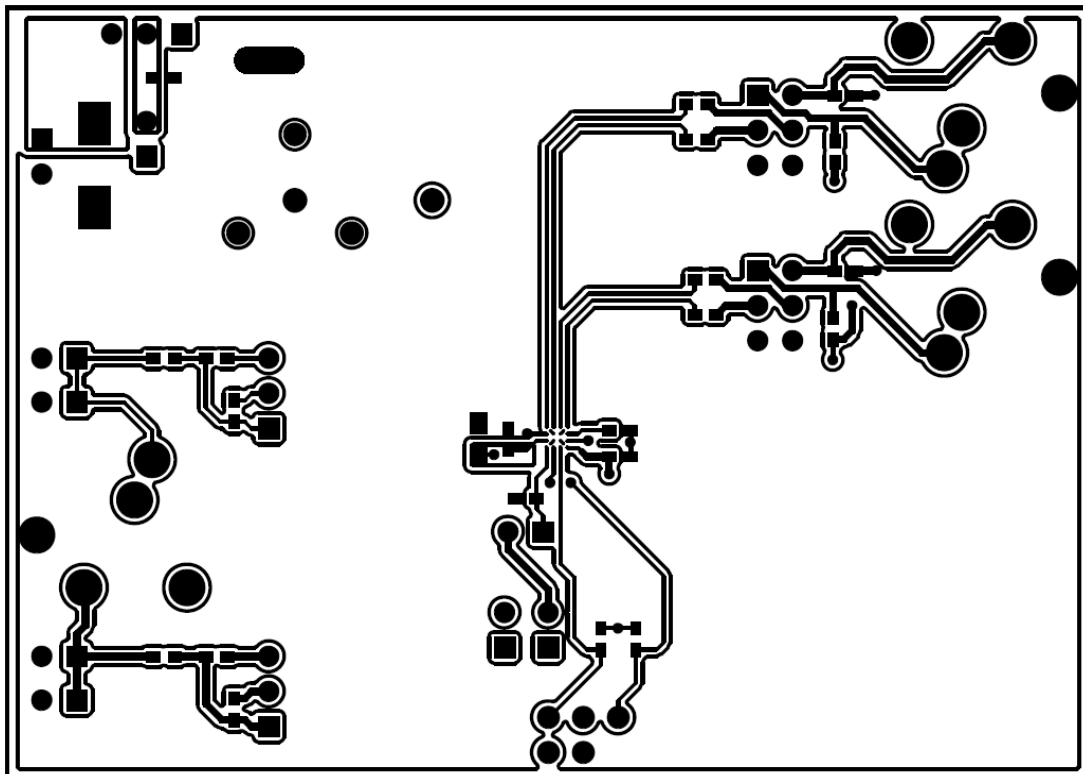

Figure 12. Layout, Top Layer

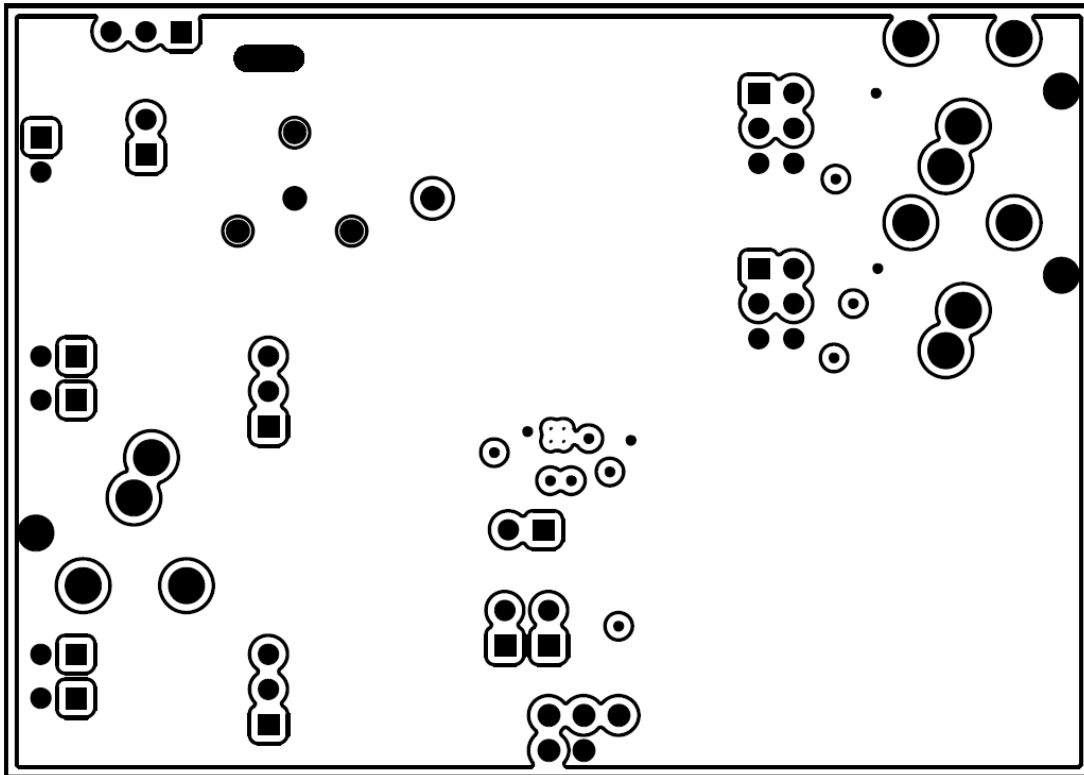

Figure 13. Layout, Top Inner Layer

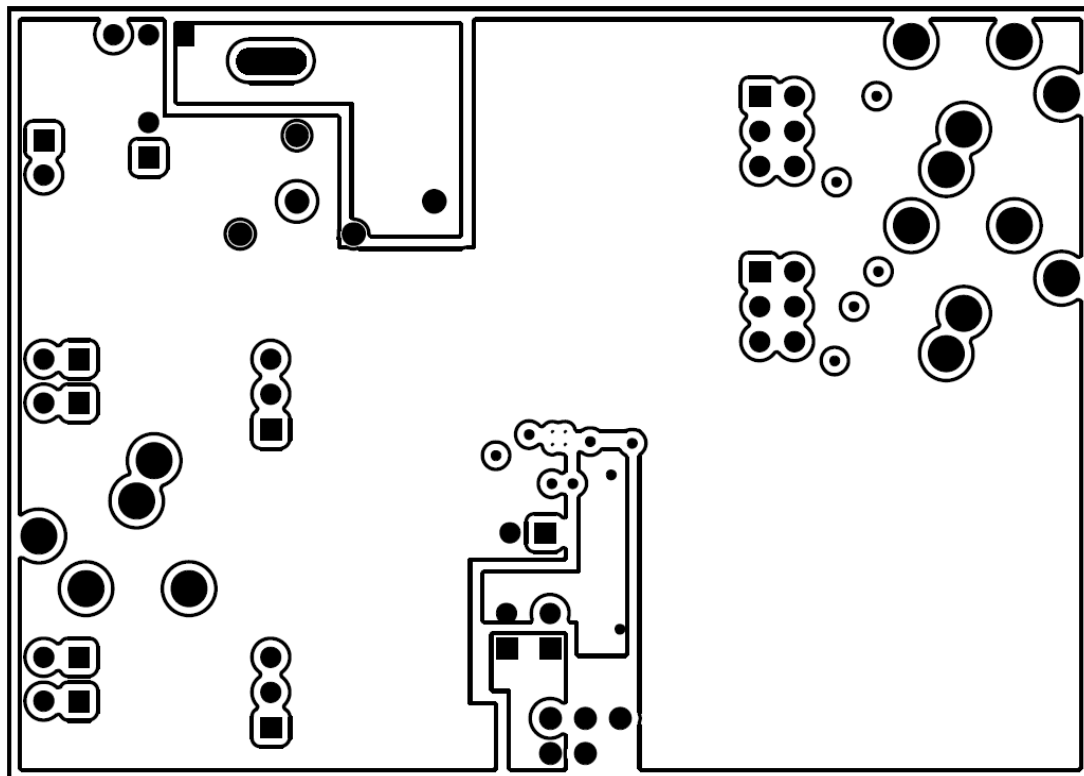

Figure 14. Layout, Bottom Inner Layer

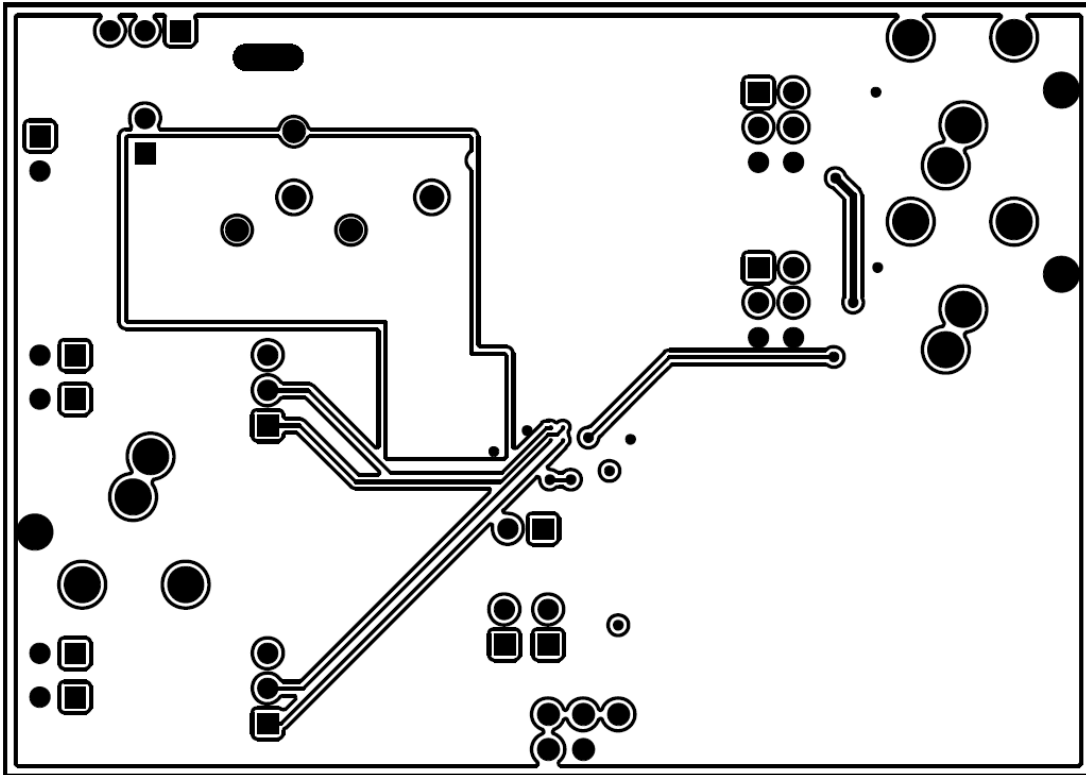

Figure 15. Layout, Bottom Layer

15 Bill of Materials

Designator	Component	Value	Tolerance	Rating	Package Type
U1	LMV1090				
C15, C16	Capacitor Ceramic	1.0 μ F	10%	16V	0603
C2	Capacitor Ceramic	10000pF	10%	50V	0603
C3, C4, C7, C8, C9	Capacitor Ceramic	0.47pF	10%	16V	0603
C5, C14	No Load	No Load			
C5A, C14A	Capacitor Ceramic	1nF	10%	100V	0603
C10, C13	Capacitor Ceramic	1 μ F	10%	16V	0603
C11	No Load	No Load			
C12	Capacitor Tantalum	100 μ F	10%	10V	Case C
R1, R2, R4, R5	Resistor	1.1k	1%	1/10W	0603
R3	Resistor	100k	1%	1/10W	0603
R9, R10	Resistor	10k	1%	1/10W	0603
J12, J13, J14, J20, J21, J22, J23, J24, J25, J27	Connector Header Brkway .100 02POS STR				
J8, J10, J20, J26	Connector Header Brkway .100 06POS STR				
J11, J16	Connector Header Brkway .100 06POS VERT				
J9, J15, J28	5 Pole Headphone conn jack stereo 3.5mm horizontal				
GND	Ground hook jumper 5mm high mount				
BT1	Battery holder CR1220, 1 cell 12mm				
J8_SH, J10_SH, J11_SH1, J11_SH2, J16_SH2, J21_SH, J22_SH, J25_SH, J26_SH, J27_SH	Jumper Shunt 0.100" 30 μ in AU (no handle)				

16 Revision History

Rev	Date	Description
1.0	05/21/09	Initial release.
1.01	06/30/09	Corrected graphic 30092061.

IMPORTANT NOTICE

Texas Instruments Incorporated and its subsidiaries (TI) reserve the right to make corrections, enhancements, improvements and other changes to its semiconductor products and services per JESD46, latest issue, and to discontinue any product or service per JESD48, latest issue. Buyers should obtain the latest relevant information before placing orders and should verify that such information is current and complete. All semiconductor products (also referred to herein as "components") are sold subject to TI's terms and conditions of sale supplied at the time of order acknowledgment.

TI warrants performance of its components to the specifications applicable at the time of sale, in accordance with the warranty in TI's terms and conditions of sale of semiconductor products. Testing and other quality control techniques are used to the extent TI deems necessary to support this warranty. Except where mandated by applicable law, testing of all parameters of each component is not necessarily performed.

TI assumes no liability for applications assistance or the design of Buyers' products. Buyers are responsible for their products and applications using TI components. To minimize the risks associated with Buyers' products and applications, Buyers should provide adequate design and operating safeguards.

TI does not warrant or represent that any license, either express or implied, is granted under any patent right, copyright, mask work right, or other intellectual property right relating to any combination, machine, or process in which TI components or services are used. Information published by TI regarding third-party products or services does not constitute a license to use such products or services or a warranty or endorsement thereof. Use of such information may require a license from a third party under the patents or other intellectual property of the third party, or a license from TI under the patents or other intellectual property of TI.

Reproduction of significant portions of TI information in TI data books or data sheets is permissible only if reproduction is without alteration and is accompanied by all associated warranties, conditions, limitations, and notices. TI is not responsible or liable for such altered documentation. Information of third parties may be subject to additional restrictions.

Resale of TI components or services with statements different from or beyond the parameters stated by TI for that component or service voids all express and any implied warranties for the associated TI component or service and is an unfair and deceptive business practice. TI is not responsible or liable for any such statements.

Buyer acknowledges and agrees that it is solely responsible for compliance with all legal, regulatory and safety-related requirements concerning its products, and any use of TI components in its applications, notwithstanding any applications-related information or support that may be provided by TI. Buyer represents and agrees that it has all the necessary expertise to create and implement safeguards which anticipate dangerous consequences of failures, monitor failures and their consequences, lessen the likelihood of failures that might cause harm and take appropriate remedial actions. Buyer will fully indemnify TI and its representatives against any damages arising out of the use of any TI components in safety-critical applications.

In some cases, TI components may be promoted specifically to facilitate safety-related applications. With such components, TI's goal is to help enable customers to design and create their own end-product solutions that meet applicable functional safety standards and requirements. Nonetheless, such components are subject to these terms.

No TI components are authorized for use in FDA Class III (or similar life-critical medical equipment) unless authorized officers of the parties have executed a special agreement specifically governing such use.

Only those TI components which TI has specifically designated as military grade or "enhanced plastic" are designed and intended for use in military/aerospace applications or environments. Buyer acknowledges and agrees that any military or aerospace use of TI components which have **not** been so designated is solely at the Buyer's risk, and that Buyer is solely responsible for compliance with all legal and regulatory requirements in connection with such use.

TI has specifically designated certain components as meeting ISO/TS16949 requirements, mainly for automotive use. In any case of use of non-designated products, TI will not be responsible for any failure to meet ISO/TS16949.

Products

Audio	www.ti.com/audio
Amplifiers	amplifier.ti.com
Data Converters	dataconverter.ti.com
DLP® Products	www.dlp.com
DSP	dsp.ti.com
Clocks and Timers	www.ti.com/clocks
Interface	interface.ti.com
Logic	logic.ti.com
Power Mgmt	power.ti.com
Microcontrollers	microcontroller.ti.com
RFID	www.ti-rfid.com
OMAP Applications Processors	www.ti.com/omap
Wireless Connectivity	www.ti.com/wirelessconnectivity

Applications

Automotive and Transportation	www.ti.com/automotive
Communications and Telecom	www.ti.com/communications
Computers and Peripherals	www.ti.com/computers
Consumer Electronics	www.ti.com/consumer-apps
Energy and Lighting	www.ti.com/energy
Industrial	www.ti.com/industrial
Medical	www.ti.com/medical
Security	www.ti.com/security
Space, Avionics and Defense	www.ti.com/space-avionics-defense
Video and Imaging	www.ti.com/video

TI E2E Community

e2e.ti.com