

LMH5485-SEP 耐 Tolerant 型负轨输入、轨到轨输出高精度 850MHz 全差分放大器

1 特性

- 抗辐射
 - 每个晶圆批次的保障 TID 高达 30krad (Si)
 - 单粒子闩锁 (SEL) 对于 LET 的抗扰度 = 43MeV-cm²/mg
 - 支持军用级温度范围: -55°C 至 125°C
- 增益带宽积 (GBWP): 850MHz
- 压摆率: 1300V/μs
- HD2、HD3: -118dBc、-147dBc (100kHz、2V_{PP})
- 输入电压噪声: 2.4 nV/√Hz
- 低温漂: ±0.5μV/°C (典型值)
- 负轨输入 (NRI)、轨到轨输出 (RRO)
- 电源:
 - 电源电压范围: 2.7V 至 5.4V
 - 静态电流: 10.1 mA
 - 断电能力: 2μA (典型值)

2 应用

- 低功耗高性能 ADC 驱动器:
 - SAR、ΔΣ 和流水线
- 差分 DAC 输出驱动器
- 命令和数据处理
- 运载火箭系统
- 空间成像系统:
 - 光学成像有效载荷
 - 雷达成像有效载荷
 - 热成像摄像机

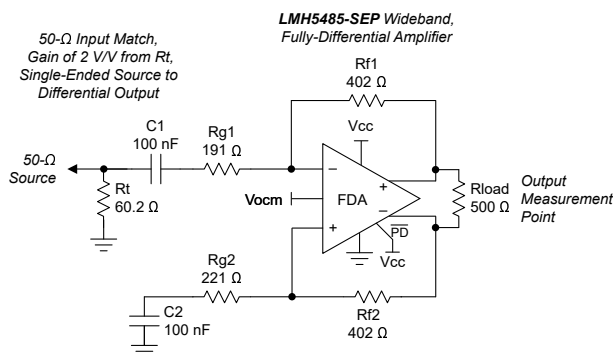

简化版原理图

3 说明

LMH5485-SEP 是一款抗辐射、低功耗、电压反馈、全差分放大器 (FDA)。该器件能够实现 850MHz 的高增益带宽积 (GBWP)，从而能够在下图所示的宽频率范围内保持出色的失真性能。此外，还可在 10.1mA 的相对较低功耗和 2.4nV/√Hz 的宽带电压噪声下实现此宽带宽范围。由于具有这样的功耗、带宽和噪声组合，LMH5485-SEP 非常适合频率大于 10MHz 且同时要求出色信噪比 (SNR) 和无杂散动态范围 (SFDR) 的功耗敏感型数据采集系统。

LMH5485-SEP 具有所需的负电源轨输入，可用于连接直流耦合、以接地为中心的源信号。此负电源轨输入搭配轨到轨输出，只需使用一个 2.7V 至 5.4V 的电源，即可轻松将单端接地基准双极信号源与各种逐次逼近寄存器 (SAR)、Δ-Σ 或流水线 ADC 相连接。该器件还具有 ±0.5 μV/°C 的低失调电压漂移，能够在 -55°C 至 +125°C 的宽温度范围内保持出色的直流性能。

封装信息⁽¹⁾⁽²⁾

器件型号	封装	封装尺寸 (标称值)
LMH5485-SEP	DGK (VSSOP, 8)	3.00mm × 3.00mm

- 如需了解所有可用封装，请参阅数据表末尾的封装选项附录。
- 请参阅 [器件信息表](#)

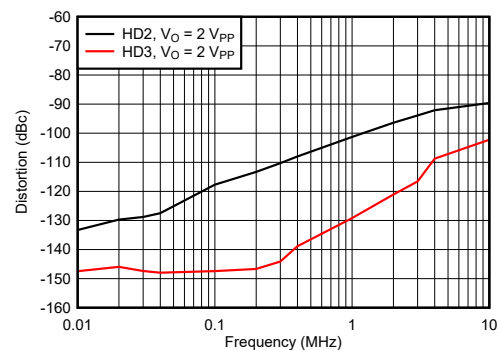

谐波失真与频率间的关系



Table of Contents

1 特性	1	9.1 Overview.....	16
2 应用	1	9.2 Functional Block Diagram.....	16
3 说明	1	9.3 Feature Description.....	17
4 Revision History	2	9.4 Device Functional Modes.....	18
5 Device Comparison Table	3	10 Application and Implementation	22
6 Pin Configuration and Functions	3	10.1 Application Information.....	22
7 Specifications	4	10.2 Typical Applications.....	22
7.1 Absolute Maximum Ratings.....	4	11 Power Supply Recommendations	26
7.2 ESD Ratings.....	4	12 Layout	26
7.3 Recommended Operating Conditions.....	4	12.1 Layout Guidelines.....	26
7.4 Thermal Information.....	5	13 Device and Documentation Support	27
7.5 Electrical Characteristics: $V_{S+} - V_{S-} = 5\text{ V}$	6	13.1 Documentation Support.....	27
7.6 Electrical Characteristics: $V_{S+} - V_{S-} = 3\text{ V}$	8	13.2 Receiving Notification of Documentation Updates..	27
7.7 Typical Characteristics: 5 V Single Supply.....	10	13.3 支持资源.....	27
7.8 Typical Characteristics: 3 V Single Supply.....	11	13.4 Trademarks.....	27
7.9 Typical Characteristics: 3 V to 5 V Supply Range.....	12	13.5 Electrostatic Discharge Caution.....	27
8 Parameter Measurement Information	15	13.6 术语表.....	27
8.1 Example Characterization Circuits.....	15	14 Mechanical, Packaging, and Orderable Information	27
9 Detailed Description	16		

4 Revision History

注：以前版本的页码可能与当前版本的页码不同

Changes from Revision * (December 2021) to Revision A (September 2022)

Page

• 将数据表的状态从 <i>预告信息</i> 更改为 <i>量产数据</i>	1
--	---

5 Device Comparison Table

DEVICE	RAD TOLERANCE	GBWP (MHz)	I _Q (mA)	HD2 / HD3 (dBc) 2 V _{PP} at 10 MHz	INPUT NOISE (nV/√Hz)	RAIL-TO-RAIL
LMH5485-SP	100 kRad TID	850	10.1	- 79 / - 97	2.4	NRI/Out
LMH5485-SEP	30 kRad TID	850	10.1	- 90 / - 102	2.4	NRI/Out
THS4513-SP	150 kRad TID	3000	37.7	- 106 / - 108	2.2	No
LMH5401-SP	100 kRad TID	6500	60	- 99 / - 100	1.25	No

6 Pin Configuration and Functions



图 6-1. DGK Package, 8-Pin VSSOP (Top View)

表 6-1. Pin Functions

PIN		TYPE ⁽¹⁾	DESCRIPTION
NAME	NO.		
IN+	8	I	Noninverting (positive) amplifier input
IN -	1	I	Inverting (negative) amplifier input
OUT+	4	O	Noninverted (positive) amplifier output
OUT -	5	O	Inverted (negative) amplifier output
PD	7	I	Power down. \overline{PD} = logic low = power-down mode; PD = logic high = normal operation.
V _{OCM}	2	I	Common-mode voltage input
V _{S+}	3	P	Positive power-supply input
V _{S-}	6	P	Negative power-supply input

(1) I = input, O = output, P = power

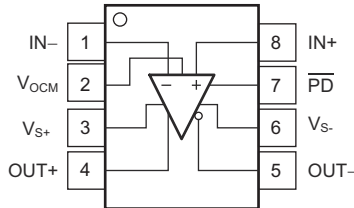
7 Specifications

7.1 Absolute Maximum Ratings

over operating free-air temperature range (unless otherwise noted)⁽¹⁾

		MIN	MAX	UNIT
Voltage ⁽²⁾	Supply voltage (normal operation), (Vs+) - (Vs-), \overline{PD} = logic high		5.5	V
	Supply voltage (power-down), (Vs+) - (Vs-), \overline{PD} = logic low		5.25	
	Input-output voltage range	(Vs-) - 0.5	(Vs+) + 0.5	
	Differential input voltage		±1	
Current	Continuous input current		±20	mA
	Continuous output current		±80	
	Continuous power dissipation	See <i>Thermal Information</i> table and <i>Thermal Analysis</i> section		
Temperature	Maximum junction temperature		150	°C
	Operating free-air temperature range	- 55	125	
	Storage temperature, T _{stg}	- 65	150	

- Operation outside the Absolute Maximum Ratings may cause permanent device damage. Absolute maximum ratings do not imply functional operation of the device at these or any other conditions beyond those listed under Recommended Operating Conditions. If briefly operating outside the Recommended Operating Conditions but within the Absolute Maximum Ratings, the device may not sustain damage, but it may not be fully functional. Operating the device in this manner may affect device reliability, functionality, performance, and shorten the device lifetime.
- If the device is under continuous operation with \overline{PD} permanently tied to VS+, absolute maximum supply voltage is 5.5V. If \overline{PD} functionality is toggled during operation, abs max supply voltage should be limited to 5.25V.

7.2 ESD Ratings

			VALUE	UNIT
V _(ESD)	Electrostatic discharge	Human-body model (HBM), per ANSI/ESDA/JEDEC JS-001 ⁽¹⁾	±2500	V
		Charged-device model (CDM), per ANSI/ESDA/JEDEC JS-002 ⁽²⁾	±1000	

- JEDEC document JEP155 states that 500-V HBM allows safe manufacturing with a standard ESD control process.
- JEDEC document JEP157 states that 250-V CDM allows safe manufacturing with a standard ESD control process.

7.3 Recommended Operating Conditions

over operating free-air temperature range (unless otherwise noted)

		MIN	NOM	MAX	UNIT
Vs+	Single-supply voltage (normal operation), \overline{PD} = logic high	2.7	5	5.4	V
	Single-supply voltage (power-down), \overline{PD} = logic low	2.7	5	5.1	
T _A	Ambient temperature	- 55	25	125	°C

7.4 Thermal Information

THERMAL METRIC ⁽¹⁾		LMH5485-SEP	UNIT
		DGK (VSSOP)	
		8 PINS	
$R_{\theta JA}$	Junction-to-ambient thermal resistance	171.8	°C/W
$R_{\theta JC(top)}$	Junction-to-case (top) thermal resistance	63.4	
$R_{\theta JB}$	Junction-to-board thermal resistance	93.4	
ψ_{JT}	Junction-to-top characterization parameter	9.2	
ψ_{JB}	Junction-to-board characterization parameter	91.9	
$R_{\theta JC(bot)}$	Junction-to-case (bottom) thermal resistance	N/A	

- (1) For more information about traditional and new thermal metrics, see the *Semiconductor and IC Package Thermal Metrics* application report, SPRA953.

7.5 Electrical Characteristics: $V_{S+} - V_{S-} = 5\text{ V}$

at $T_A = -55^\circ\text{C}$ to 125°C , $V_{OCM} = \text{open}$ (defaults midsupply), $V_{out} = 2 V_{PP}$, $R_f = 402\ \Omega$, $R_{load} = 499\ \Omega$, $50\text{-}\Omega$ input match, $G = 2\text{ V/V}$, single-ended input, differential output, and $\overline{PD} = V_{S+}$, unless otherwise noted. See [Figure 8-1](#) for an AC-coupled gain of a 2-V/V test circuit, and [Figure 8-2](#) for a DC-coupled gain of a 2-V/V test circuit.

PARAMETER		TEST CONDITIONS		MIN	TYP	MAX	UNIT
AC PERFORMANCE							
SSBW	Small-signal bandwidth	Vout = 100 mV _{PP} , G = 1		590		MHz	
		Vout = 100 mV _{PP} , G = 2		495			
		Vout = 100 mV _{PP} , G = 5		185			
		Vout = 100 mV _{PP} , G = 10		110			
GBWP	Gain-bandwidth product	Vout = 100 mV _{PP} , G = 20		850			
LSBW	Large-signal bandwidth	Vout = 2 V _{PP}		295			
	Bandwidth for 0.1-dB flatness	Vout = 2 V _{PP}		125			
	Slew rate ⁽¹⁾	Vout = 2-V _{PP} , FPBW		1300		V/ μs	
	Rise/fall time	Vout = 2-V step, input $\leq 0.5\text{ ns } t_r$		1.3		ns	
	Settling time	Vout = 2-V step, $t_r = 2\text{ ns}$	To 1%	4			
			To 0.1%	8			
	Overshoot and undershoot	Vout = 2-V step, input $\leq 0.3\text{ ns } t_r$		10%			
HD	100-kHz harmonic distortion	Vout = 2 V _{PP}	HD2	- 118		dBc	
			HD3	- 147			
	10-MHz harmonic distortion	Vout = 2 V _{PP}	HD2	- 90			
			HD3	- 102			
	2nd-order intermodulation distortion	f = 10 MHz, 100-kHz tone spacing, Vout envelope = 2 V _{PP} (1 V _{PP} per tone)		- 90			
	3rd-order intermodulation distortion			- 85			
e_n	Input voltage noise	f > 100 kHz		2.4		nV/ $\sqrt{\text{Hz}}$	
i_n	Input current noise	f > 1 MHz		1.9		pA/ $\sqrt{\text{Hz}}$	
	Overdrive recovery time	2x output overdrive, either polarity		20		ns	
Z_{OUT}	Closed-loop output impedance	f = 10 MHz (differential)		0.1		Ω	
DC PERFORMANCE							
A_{OL}	Open-loop voltage gain			97	119	dB	
V_{OS}	Input-referred offset voltage			- 900	± 100	900	μV
	Input offset voltage drift ⁽²⁾			- 2.5	± 0.5	2.5	$\mu\text{V}/^\circ\text{C}$
I_{B+}, I_{B-}	Input bias current	Positive out of node		1.7	10	15	μA
	Input bias current drift ⁽²⁾			6		15	nA/ $^\circ\text{C}$
I_{OS}	Input offset current			- 650	± 150	650	nA
	Input offset current drift ⁽²⁾			- 1.5	± 0.3	1.5	nA/ $^\circ\text{C}$
INPUT							
V_{ICML}	Common-mode input low	< 3-dB degradation in CMRR from midsupply		$(V_{S-}) - 0.2$		V_{S-}	V
V_{ICMH}	Common-mode input high			$(V_{S+}) - 1.3$	$(V_{S+}) - 1.2$		
CMRR	Common-mode rejection ratio	Input pins at midsupply		82	100	dB	
	Input impedance differential mode	Input pins at midsupply		110 0.9		k Ω pF	

7.5 Electrical Characteristics: Vs+ - Vs- = 5 V (continued)

at T_A = -55°C to 125°C, V_{OCM} = open (defaults midsupply), V_{out} = 2 V_{PP}, R_f = 402 Ω, R_{load} = 499 Ω, 50-Ω input match, G = 2 V/V, single-ended input, differential output, and PD = Vs+, unless otherwise noted. See [Figure 8-1](#) for an AC-coupled gain of a 2-V/V test circuit, and [Figure 8-2](#) for a DC-coupled gain of a 2-V/V test circuit.

PARAMETER	TEST CONDITIONS	MIN	TYP	MAX	UNIT		
OUTPUT							
Output voltage low			(Vs-) + 0.2	(Vs-) + 0.25	V		
Output voltage high		(Vs+) - 0.25	(Vs+) - 0.2				
Output current drive		±75	±100		mA		
POWER SUPPLY							
I _Q	Quiescent operating current	9.2	10.1	11	mA		
PSRR	Power-supply rejection ratio	Either supply pin to differential V _{out}		82	100	dB	
POWER DOWN							
V _{EN}	Enable voltage threshold	(Vs-) + 1.7			V		
V _{DIS}	Disable voltage threshold	(Vs-) + 0.7					
	Disable pin bias current	PD = Vs- → Vs+		20	50	nA	
	Power-down quiescent current	PD = (Vs-) + 0.7 V		6	30	μA	
		PD = Vs-		2	8		
	Turnon-time delay	Time from PD = low to V _{out} = 90% of final value		100	ns		
	Turnoff time delay	Time from PD = low to V _{out} = 10% of final value		60			
OUTPUT COMMON-MODE VOLTAGE CONTROL⁽³⁾							
	Small-signal bandwidth	V _{OCM} = 100 mV _{PP}		150	MHz		
	Slew rate ⁽¹⁾	V _{OCM} = 2-V step		400	V/μs		
	Gain	0.975	0.982	0.995	V/V		
	Input bias current	Considered positive out of node		- 0.8	0.1	0.8	μA
	Input impedance	V _{OCM} input driven to midsupply		47 1.2		kΩ pF	
	Default voltage offset from midsupply	V _{OCM} pin open		- 45	±8	45	mV
	Common-mode offset voltage	V _{OCM} input driven to midsupply		- 8	±2	8	
	CM V _{OS} drift ⁽²⁾	V _{OCM} input driven to midsupply		- 20	±4	+20	μV/°C
	Common-mode loop supply headroom to negative supply	< ±15-mV shift from midsupply CM V _{OS}		0.94		V	
	Common-mode loop supply headroom to positive supply	< ±15-mV shift from midsupply CM V _{OS}		1.2			

- (1) This slew rate is the average of the rising and falling time estimated from the large-signal bandwidth as: $(V_P / \sqrt{2}) \times 2 \pi \times f_{-3dB}$.
- (2) Input offset voltage drift, input bias current drift, input offset current drift, and V_{OCM} drift are average values calculated by taking data at the at the maximum-range ambient-temperature end-points, computing the difference, and dividing by the temperature range.
- (3) Specifications are from the input V_{OCM} pin to the differential output average voltage.

7.6 Electrical Characteristics: $V_{S+} - V_{S-} = 3\text{ V}$

at $T_A = -55^\circ\text{C}$ to 125°C , $V_{OCM} = \text{open}$ (defaults midsupply), $V_{out} = 2 V_{PP}$, $R_f = 402\ \Omega$, $R_{load} = 499\ \Omega$, $50\text{-}\Omega$ input match, $G = 2\text{ V/V}$, single-ended input, differential output, and $\overline{PD} = V_{S+}$, unless otherwise noted. See [Figure 8-1](#) for an AC-coupled gain of a 2-V/V test circuit, and [Figure 8-2](#) for a DC-coupled gain of a 2-V/V test circuit.

PARAMETER		TEST CONDITIONS	MIN	TYP	MAX	UNIT
AC PERFORMANCE						
	Small-signal bandwidth	$V_{out} = 100\text{ mV}_{PP}$, $G = 1$		585		MHz
		$V_{out} = 100\text{ mV}_{PP}$, $G = 2$		490		MHz
		$V_{out} = 100\text{ mV}_{PP}$, $G = 5$		180		MHz
GBWP	Gain-bandwidth product	$V_{out} = 100\text{ mV}_{PP}$, $G = 20$		850		MHz
	Large-signal bandwidth	$V_{out} = 2 V_{PP}$		275		MHz
	Bandwidth for 0.1-dB flatness	$V_{out} = 2 V_{PP}$		120		MHz
	Slew rate ⁽¹⁾	$V_{out} = 2\text{-V step}$, FPBW		1200		V/ μs
	Rise/fall time	$V_{out} = 2\text{-V step}$, input $\leq 0.5\text{ ns } t_r$		1.6		ns
	Settling time	$V_{out} = 2\text{-V step}$, $t_r = 2\text{ ns}$	To 1%	5		ns
			To 0.1%	8		ns
	Overshoot and undershoot	$V_{out} = 2\text{-V step}$, input $\leq 0.3\text{ ns } t_r$		11%		
	100-kHz harmonic distortion	$V_{out} = 2 V_{PP}$	HD2	-118		dBc
			HD3	-148		dBc
	10-MHz harmonic distortion	$V_{out} = 2 V_{PP}$	HD2	-90		dBc
			HD3	-100		dBc
	2nd-order intermodulation distortion	$f = 10\text{ MHz}$, 100-kHz tone spacing, V_{out} envelope = $2 V_{PP}$ (1 V_{PP} per tone)		-89		dBc
	3rd-order intermodulation distortion			-87		dBc
e_n	Input voltage noise	$f > 100\text{ kHz}$		2.4		nV/ $\sqrt{\text{Hz}}$
i_n	Input current noise	$f > 1\text{ MHz}$		1.9		pA/ $\sqrt{\text{Hz}}$
	Overdrive recovery time	2X output overdrive, either polarity		20		ns
	Closed-loop output impedance	$f = 10\text{ MHz}$ (differential)		0.1		Ω
DC PERFORMANCE						
A_{OL}	Open-loop voltage gain		97	119		dB
	Input-referred offset voltage		-900	± 100	900	μV
	Input offset voltage drift ⁽²⁾		-2.5	± 0.5	2.5	$\mu\text{V}/^\circ\text{C}$
	Input bias current	Positive out of node	1.7	9	15	μA
	Input bias current drift ⁽²⁾			5	15	nA/ $^\circ\text{C}$
	Input offset current		-650	± 150	650	nA
	Input offset current drift ⁽²⁾		-1.5	± 0.3	1.5	nA/ $^\circ\text{C}$
INPUT						
	Common-mode input low	< 3-dB degradation in CMRR from midsupply		$(V_{S-}) - 0.2$	V_{S-}	V
	Common-mode input high	< 3-dB degradation in CMRR from midsupply	$(V_{S+}) - 1.3$	$(V_{S+}) - 1.2$		V
	Common-mode rejection ratio	Input pins at midsupply	82	100		dB
	Input impedance differential mode	Input pins at midsupply		$110 \parallel 0.9$		k Ω pF

7.6 Electrical Characteristics: Vs+ - Vs- = 3 V (continued)

at $T_A = -55^\circ\text{C}$ to 125°C , $V_{OCM} = \text{open}$ (defaults midsupply), $V_{out} = 2 V_{PP}$, $R_f = 402 \Omega$, $R_{load} = 499 \Omega$, $50\text{-}\Omega$ input match, $G = 2 \text{ V/V}$, single-ended input, differential output, and $\overline{PD} = V_{s+}$, unless otherwise noted. See [Figure 8-1](#) for an AC-coupled gain of a 2-V/V test circuit, and [Figure 8-2](#) for a DC-coupled gain of a 2-V/V test circuit.

PARAMETER	TEST CONDITIONS	MIN	TYP	MAX	UNIT	
OUTPUT						
Output voltage low			$(V_{s-}) + 0.2$	$(V_{s-}) + 0.25$	V	
Output voltage high		$(V_{s+}) - 0.25$	$(V_{s+}) - 0.2$		V	
Output current drive		± 55	± 60		mA	
POWER SUPPLY						
Specified operating voltage		2.7	3	5.1	V	
Quiescent operating current		9	9.7	10.6	mA	
\pm PSRR	Power-supply rejection ratio	Either supply pin to differential V_{out}	82	100	dB	
POWER DOWN						
Enable voltage threshold		$(V_{s-}) + 1.7$			V	
Disable voltage threshold			$(V_{s-}) + 0.7$		V	
Disable pin bias current	$\overline{PD} = V_{s-} \rightarrow V_{s+}$		20	50	nA	
Power-down quiescent current	$\overline{PD} = (V_{s-}) + 0.7 \text{ V}$		2	30	μA	
	$\overline{PD} = V_{s-}$		1	8	μA	
Turnon-time delay	Time from $\overline{PD} = \text{low}$ to $V_{out} = 90\%$ of final value		100		ns	
Turnoff time delay	Time from $\overline{PD} = \text{low}$ to $V_{out} = 10\%$ of final value		60		ns	
OUTPUT COMMON-MODE VOLTAGE CONTROL⁽³⁾						
Small-signal bandwidth	$V_{OCM} = 100 \text{ mV}_{PP}$		140		MHz	
Slew rate ⁽¹⁾	$V_{OCM} = 1\text{-V}$ step		350		V/ μs	
Gain		0.975	0.987	0.990	V/V	
Input bias current	Considered positive out of node	-0.7	0.1	0.7	μA	
Input impedance	V_{OCM} input driven to midsupply		$47 \parallel 1.2$		$\text{k}\Omega \parallel \text{pF}$	
Default voltage offset from midsupply	V_{OCM} pin open	-45	± 10	45	mV	
CM V_{OS}	Common-mode offset voltage	V_{OCM} input driven to midsupply	-8	± 2	8	mV
	CM V_{OS} drift ⁽²⁾	V_{OCM} input driven to midsupply	-20	± 4	20	$\mu\text{V}/^\circ\text{C}$
	Common-mode loop supply headroom to negative supply	$< \pm 15\text{-mV}$ shift from midsupply CM V_{OS}	0.94		V	
	Common-mode loop supply headroom to positive supply	$< \pm 15\text{-mV}$ shift from midsupply CM V_{OS}	1.2		V	

- (1) This slew rate is the average of the rising and falling time estimated from the large-signal bandwidth as: $(V_P / \sqrt{2}) \times 2\pi \times f_{-3dB}$.
- (2) Input offset voltage drift, input bias current drift, input offset current drift, and V_{OCM} drift are average values calculated by taking data at the at the maximum-range ambient-temperature end-points, computing the difference, and dividing by the temperature range. Maximum drift set by distribution of a large sampling of devices. Drift is not specified by test or QA sample test.
- (3) Specifications are from input V_{OCM} pin to differential output average voltage.

7.7 Typical Characteristics: 5 V Single Supply

at $V_{s+} = 5\text{ V}$, $V_{s-} = \text{GND}$, $R_F = 402\ \Omega$, V_{OCM} is open, $50\ \Omega$ single-ended input to differential output, gain = 2 V/V, $R_{load} = 500\ \Omega$, and $T_A \approx 25^\circ\text{C}$ (unless otherwise noted)



图 7-1. Small-Signal Frequency Response vs Gain



图 7-2. Large-Signal Frequency Response

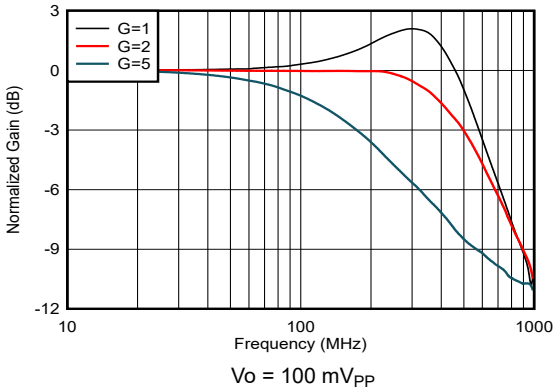

50 MHz input, 0.5-ns input edge rate, single-ended to differential output, split supply, DC-coupled, see 图 8-2

图 7-3. Large-Signal Step Response

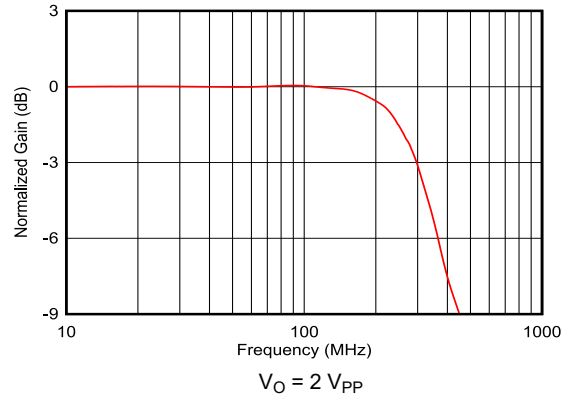
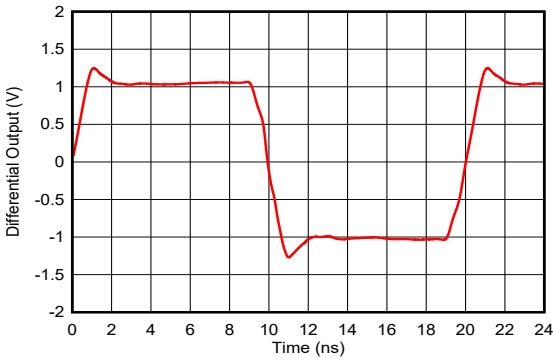

图 7-4. Harmonic Distortion Over Frequency

7.8 Typical Characteristics: 3 V Single Supply

at $V_{S+} = 3\text{ V}$, $V_{S-} = \text{GND}$, V_{OCM} is open, $50\ \Omega$ single-ended input to differential output, gain = 2 V/V, $R_{\text{load}} = 500\ \Omega$, and $T_A \cong 25^\circ\text{C}$ (unless otherwise noted)

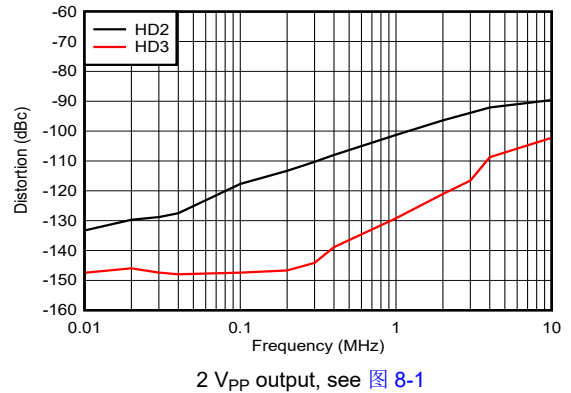
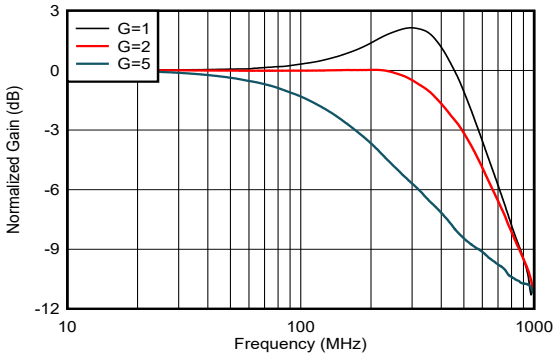

$R_f = 402\ \Omega$, $V_{\text{out}} = 100\ \text{mV}_{\text{PP}}$

图 7-5. Small-Signal Frequency Response vs Gain

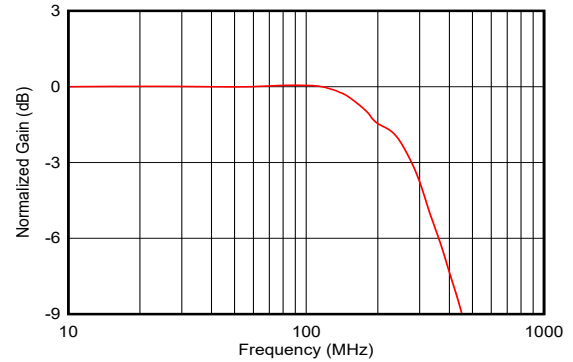

$R_f = 402\ \Omega$, $V_{\text{out}} = 2\ \text{V}_{\text{PP}}$

图 7-6. Large-Signal Frequency Response

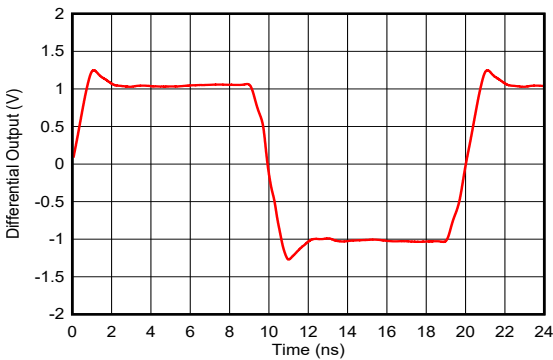

50 MHz input, 0.5-ns input edge rate, single-ended input to differential output, split supply, DC coupled, see 图 8-2

图 7-7. Large-Signal Step Response

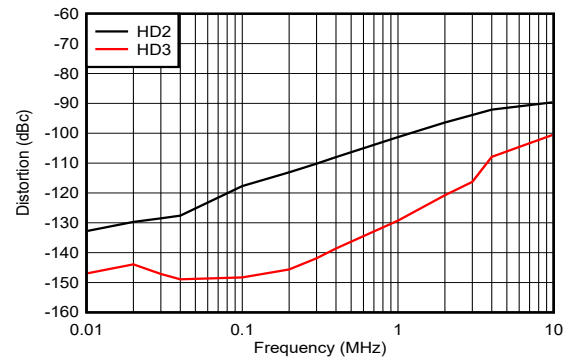

2 V_{PP} output, see 图 8-1 with $V_{S+} = 3\text{ V}$, $V_{\text{OCM}} = 1.5\text{ V}$

图 7-8. Harmonic Distortion Over Frequency

7.9 Typical Characteristics: 3 V to 5 V Supply Range

at $V_{s+} = 3\text{ V}$ and 5 V , $V_{s-} = \text{GND}$, V_{OCM} is open, $50\ \Omega$ single-ended input to differential output, gain = 2 V/V, $R_{\text{load}} = 500\ \Omega$, and $T_A \approx 25^\circ\text{C}$ (unless otherwise noted)



图 7-9. Main Amplifier Differential Open-Loop Gain and Phase vs Frequency



Single-ended input to differential output, simulated differential output impedance, see 图 8-1

图 7-10. Closed-Loop Output Impedance

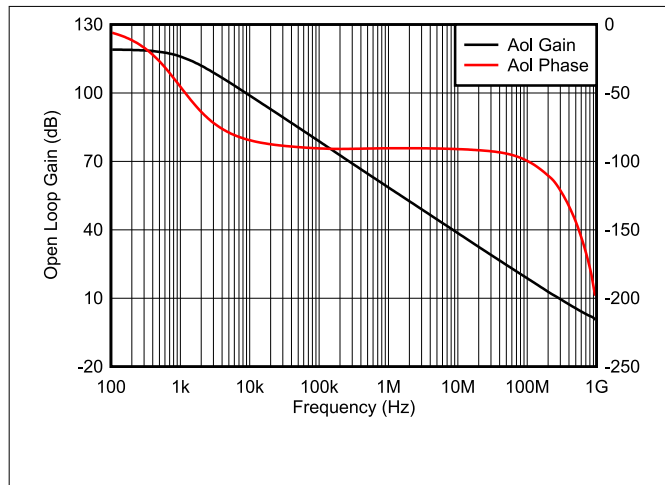
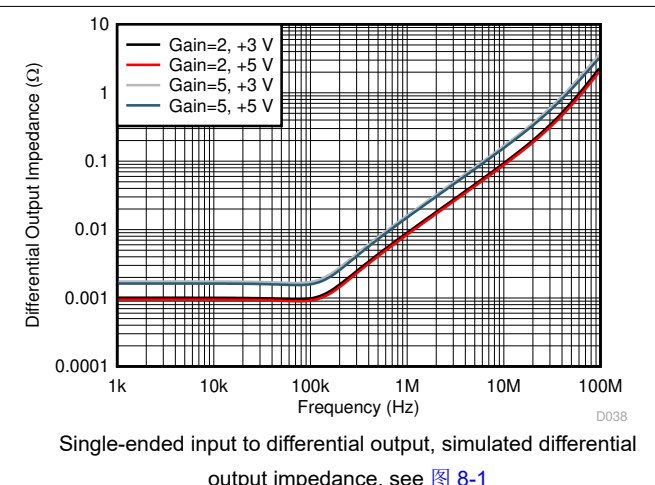

图 7-11. Input Spot Noise Over Frequency



Single-ended input to differential output, gain of 2 (see 图 8-1), simulated with 1% resistor, worst-case mismatch

图 7-12. Output Balance Error Over Frequency

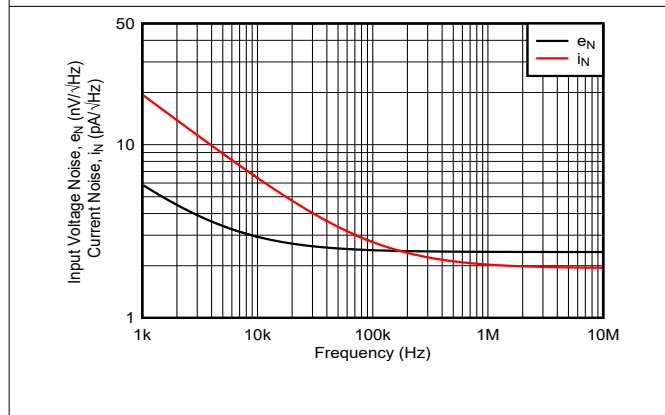
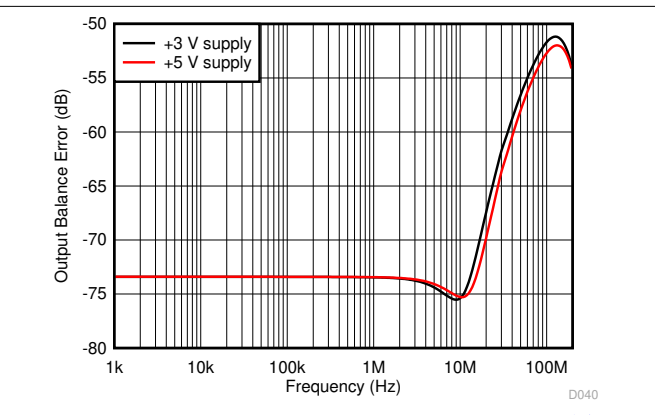
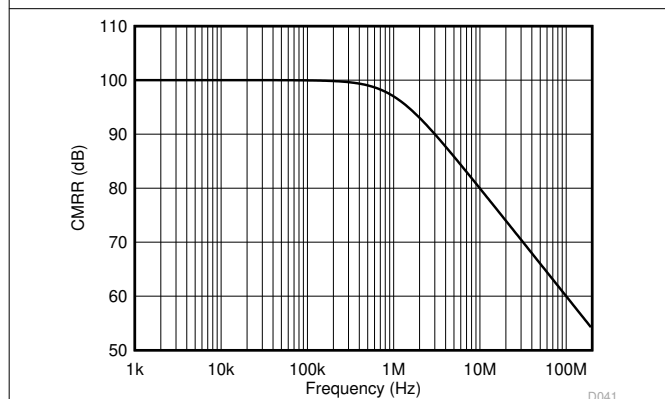

Common-mode in to differential out, gain of 2 simulation

图 7-13. CMRR Over Frequency

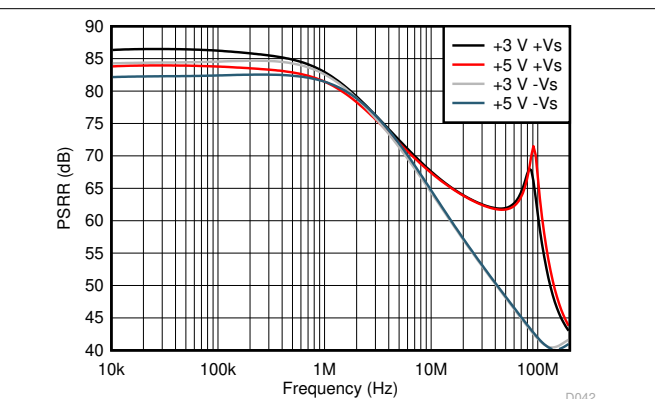

Single-ended to differential, gain of 2 (see 图 8-1) PSRR simulated to differential output

图 7-14. PSRR Over Frequency

7.9 Typical Characteristics: 3 V to 5 V Supply Range (continued)

at $V_{s+} = 3\text{ V}$ and 5 V , $V_{s-} = \text{GND}$, V_{OCM} is open, $50\ \Omega$ single-ended input to differential output, gain = 2 V/V , $R_{\text{load}} = 500\ \Omega$, and $T_A \approx 25^\circ\text{C}$ (unless otherwise noted)

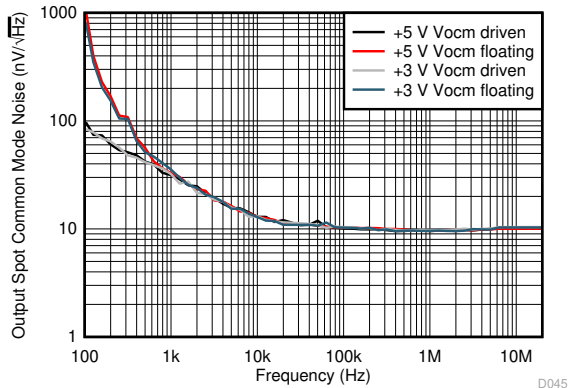

V_{OCM} input either driven to mid-supply by low impedance source, or allowed to float and default to mid-supply

图 7-15. Output Common-Mode Noise

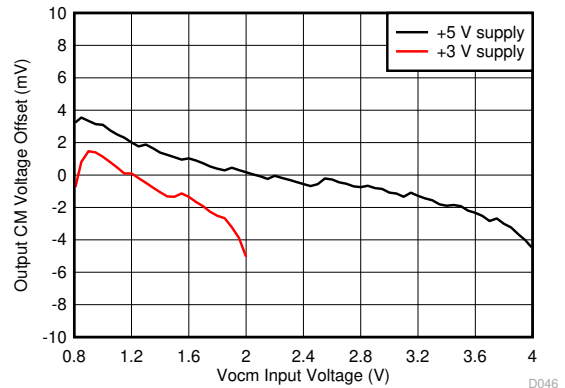

Average V_{OCM} output offset of 37 units, Standard deviation $< 2.5\text{ mV}$, see 图 8-2

图 7-16. V_{OCM} Offset vs V_{OCM} Setting

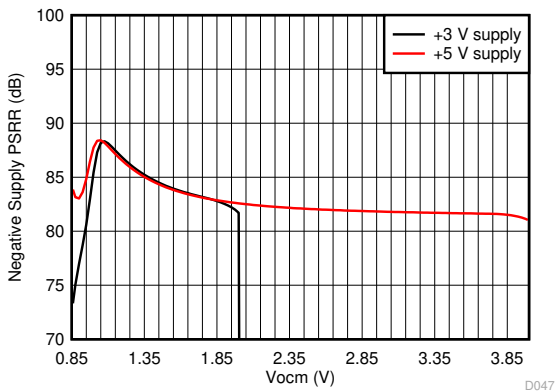

Single-ended to differential gain of 2 (see 图 8-1), PSRR for negative supply to differential output (1-kHz simulation)

图 7-17. -PSRR vs V_{OCM} Approaching V_{s-}

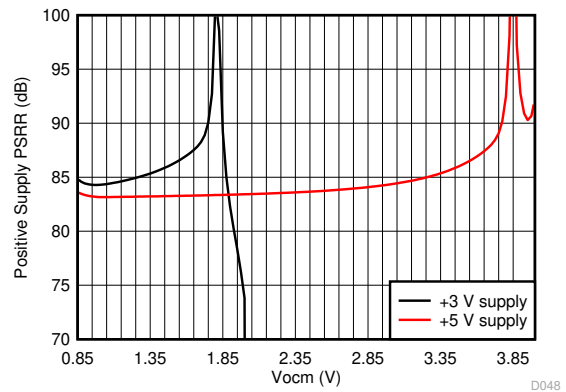

Single-ended to differential gain of 2 (see 图 8-1), PSRR for positive supply to differential output (1-kHz simulation)

图 7-18. +PSRR vs V_{OCM} Approaching V_{s+}

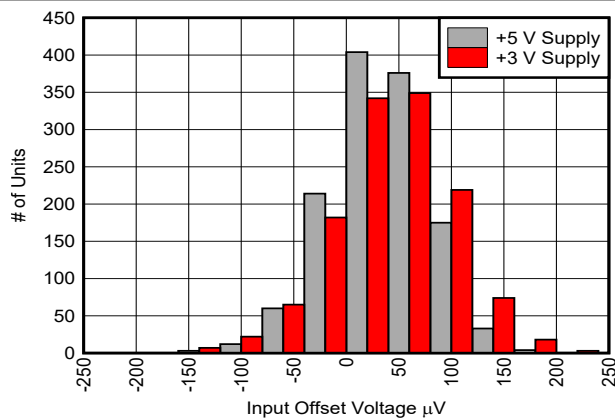

Total of 1281 units for each supply. For $V_{s+} = 5\text{ V}$: $\mu = 34.1\ \mu\text{V}$, $\sigma = 47.1\ \mu\text{V}$

图 7-19. Input Offset Voltage

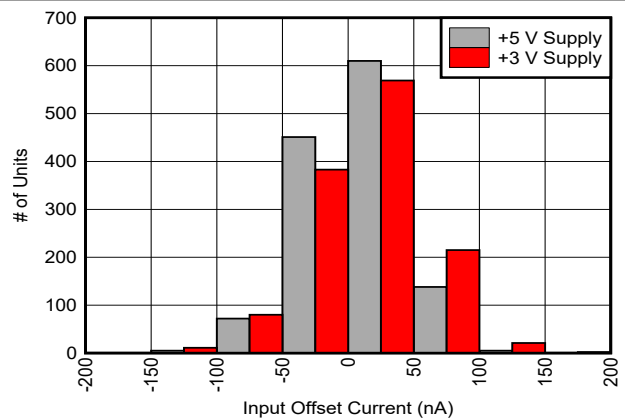

Total of 1281 units for each supply. For $V_{s+} = 5\text{ V}$: $\mu = 7.0\text{ nA}$, $\sigma = 35.9\text{ nA}$

图 7-20. Input Offset Current

7.9 Typical Characteristics: 3 V to 5 V Supply Range (continued)

at $V_{s+} = 3\text{ V}$ and 5 V , $V_{s-} = \text{GND}$, V_{OCM} is open, $50\ \Omega$ single-ended input to differential output, gain = 2 V/V , $R_{\text{load}} = 500\ \Omega$, and $T_A \approx 25^\circ\text{C}$ (unless otherwise noted)



图 7-21. Differential Output Voltage vs Rload



图 7-22. Supply Current vs PD Voltage

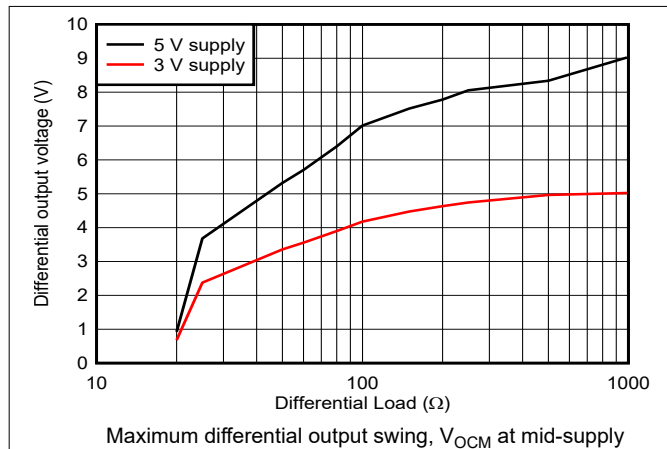

图 7-23. Common-Mode Output Offset from $V_{s+} / 2$ Default Value

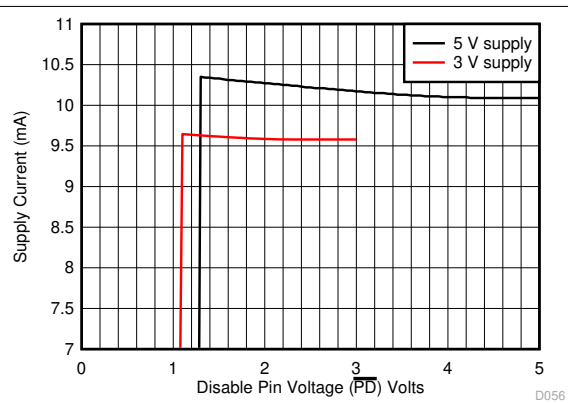

图 7-24. Common-Mode Output Offset from Driven V_{OCM}

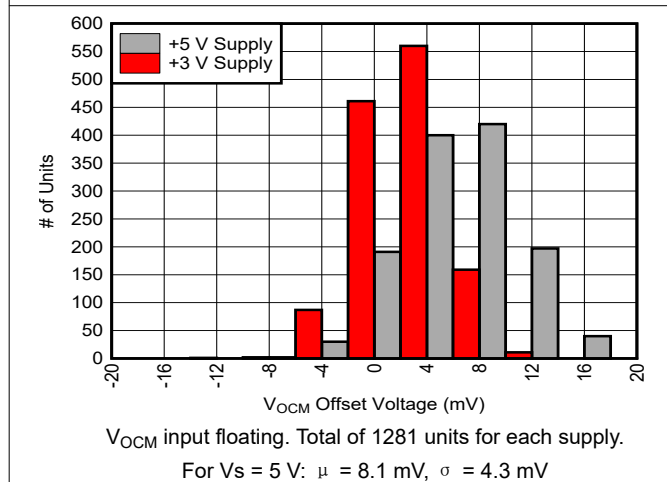

10 MHz, 1 V_{PP} input single to differential gain of 2,
see 图 8-2

图 7-25. PD Turn On Waveform

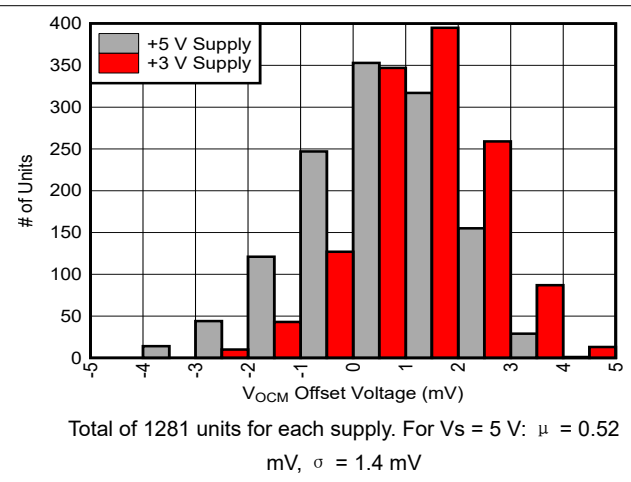
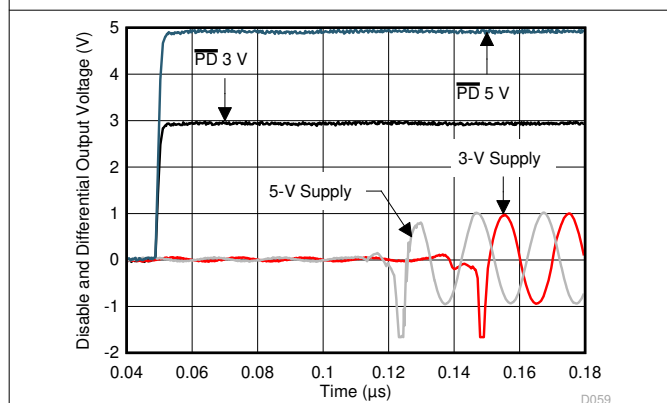
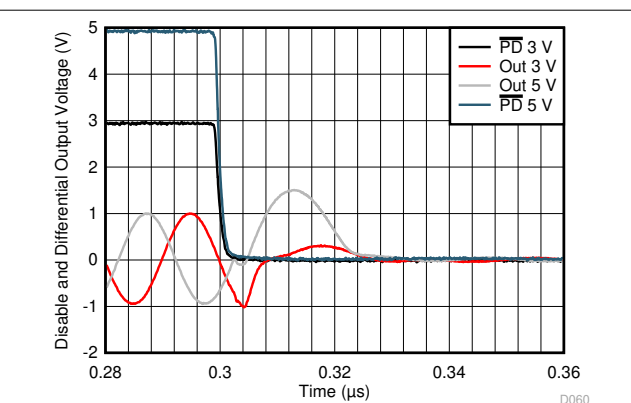

10 MHz, 1 V_{PP} input single to differential gain of 2,
see 图 8-2

图 7-26. PD Turn Off Waveform

8 Parameter Measurement Information

8.1 Example Characterization Circuits

The LMH5485-SEP offers the advantages of a fully differential amplifier (FDA) design, with the trimmed input offset voltage of a precision op amp. The FDA is an extremely flexible device that provides a purely differential output signal centered on a settable output common-mode level. The primary options revolve around the choices of single-ended or differential inputs, AC-coupled or DC-coupled signal paths, gain targets, and resistor Value selections. Differential sources can certainly be supported and are often simpler to both implement and analyze. Examples of both AC and DC coupled single-ended to differential circuits is shown in [图 8-1](#) and [图 8-2](#).

Because most lab equipment is single-ended, the characterization circuits typically operate with a single-ended, matched, 50 Ω input termination to a differential output at the FDA output pins. That output is then translated back to single-ended through a variety of baluns (or transformers) depending on the test and frequency range. DC-coupled, step-response testing uses two 50 Ω scope inputs with trace math.



图 8-1. AC-Coupled, Single-Ended Source to a Differential Gain of a 2 V/V Test Circuit



图 8-2. DC-Coupled, Single-Ended-to-Differential, Basic Test Circuit Set for a Gain of 5 V/V

[图 8-1](#) shows how most characterization plots fix the R_f value at 402 Ω . This value is completely flexible in application, but the 402 Ω provides a good compromise for the issues linked to this value, specifically:

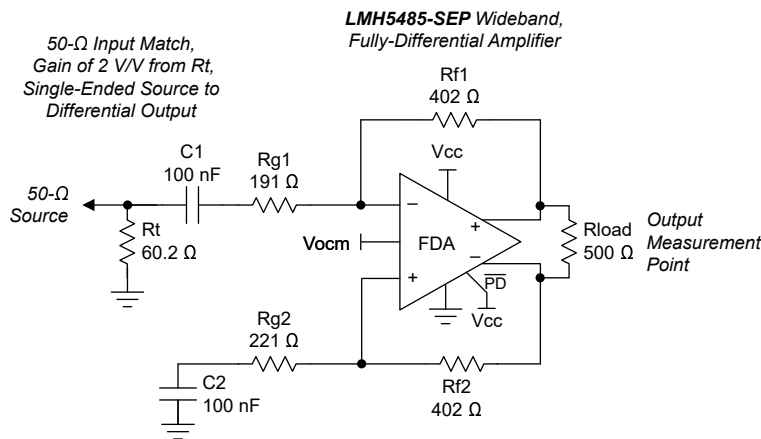
- Added output loading. The FDA appears like an inverting op amp design with both feedback resistors as an added load across the outputs (approximate total differential load in [图 8-1](#) is 500 Ω || 804 Ω = 308 Ω).
- Noise contributions because of the resistor values. The resistors contribute both a $4kTR$ term and provide gain for the input current noise.

- Parasitic feedback pole at the input summing nodes. This pole created by the feedback R value and the differential input capacitance (as well as any board layout parasitic) introduces a zero in the noise gain, decreasing the phase margin in most situations. This effect must be managed for best frequency response flatness or step response overshoot. The 402 Ω value selected does degrade the phase margin slightly over a lower value, but does not decrease the loading significantly from the nominal 500 Ω value across the output pins.

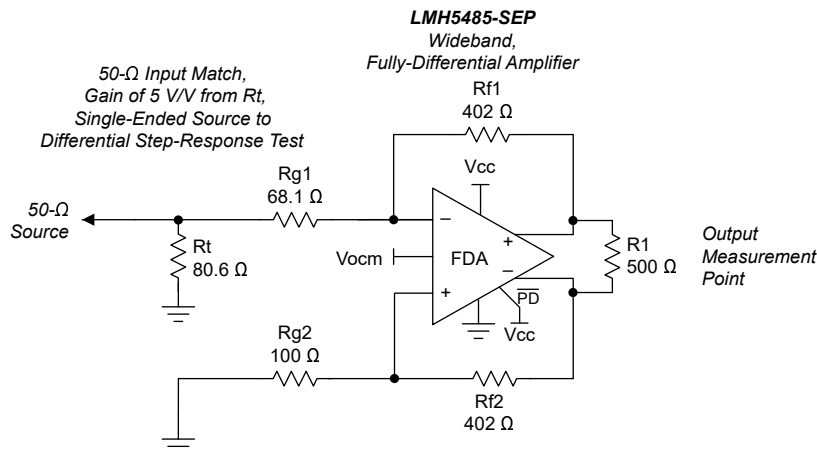
9 Detailed Description

9.1 Overview

The LMH5485-SEP is a voltage-feedback (VFA) based, fully-differential amplifier (FDA) with a trimmed supply current and input offset voltage. The core differential amplifier is a slightly decompensated voltage-feedback design with a high slew-rate, precision input stage. This design gives a MHz gain of 2 V/V small-signal bandwidth shown in the characterization curves, with a V/ μ s slew rate, yielding approximately a MHz, 2 V_{PP}, large-signal bandwidth in the same circuit configuration.

The outputs offer near rail-to-rail output swing (0.2 V headroom to either supply), while the device inputs are negative rail inputs with approximately 1.2 V of headroom required to the positive supply. [Figure 8-2](#) shows how this negative rail input directly supports a bipolar input around ground in a DC-coupled, single-supply design. Similar to all FDA devices, the output average voltage (common-mode) is controlled by a separate common-mode loop. The target for this output average is set by the V_{OCM} input pin that can be either floated to default near mid-supply or driven to a desired output common-mode voltage. The V_{OCM} range extends from a very low 0.91 V above the negative supply to 1.1 V below the positive supply, supporting a wide range of modern analog-to-digital converter (ADC) input common-mode requirements using a single 2.7 V to 5.4 V supply range for the LMH5485-SEP.

A power-down pin ($\overline{\text{PD}}$) is included. Pull the $\overline{\text{PD}}$ pin voltage to the negative supply to turn the device off, putting the LMH5485-SEP into a very-low quiescent current state. To be able to use the full supply range of the device, the device must be kept in normal operation by keeping the $\overline{\text{PD}}$ pin asserted high. When the device is disabled, remember that the signal path is still present through the passive external resistors. Input signals applied to a disabled LMH5485-SEP still appear at the outputs at some level through this passive resistor path as they would for any disabled FDA device.

9.2 Functional Block Diagram

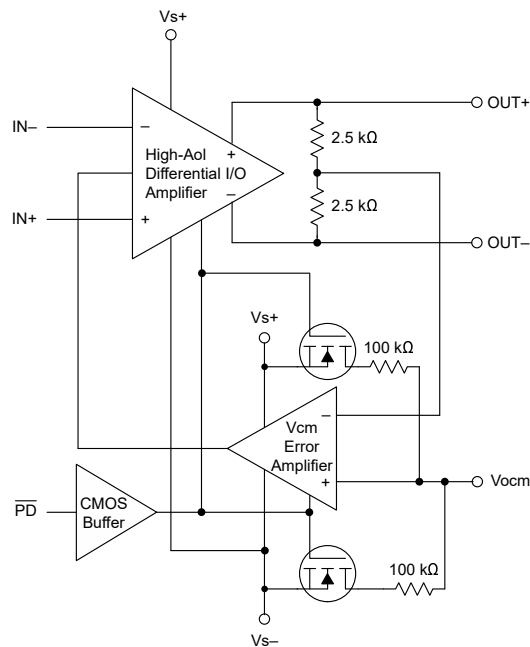

9.3 Feature Description

9.3.1 Differential I/O

The LMH5485-SEP combines a core differential I/O, high-gain block with an output common-mode sense that is compared to a reference voltage and then fed back into the main amplifier block to control the average output to that reference. The differential I/O block is a classic, high open-loop gain stage with a dominant pole at approximately 900 Hz. This voltage feedback structure projects a single-pole, unity-gain Aol at 850 MHz (gain bandwidth product). The high-speed differential outputs include an internal averaging resistor network to sense the output common-mode voltage. This voltage is compared by a separate Vcm error amplifier to the voltage on the V_{OCM} pin. If floated, this reference is at half the total supply voltage across the device using two 100-k Ω resistors. This Vcm error amplifier transmits a correction signal into the main amplifier to force the output average voltage to meet the target voltage on the V_{OCM} pin. The bandwidth of this error amplifier is approximately the same bandwidth as the main differential I/O amplifier.

The differential outputs are collector outputs to obtain the rail-to-rail output swing. These outputs are relatively high-impedance, open-loop sources; however, closing the loop provides a very low output impedance for load driving. No output current limit or thermal shutdown features are provided in this lower-power device. The differential inputs are PNP inputs to provide a negative-rail input range.

To operate the LMH5485-SEP connect the OUT⁻ pin to the IN⁺ pin through an R_f, and the OUT⁺ pin to the IN⁻ pin through the same value of R_f. Bring in the inputs through additional resistors to the IN⁺ and IN⁻ pins. The differential I/O op amp operates similarly to an inverting op amp structure where the source must drive the input resistor and the gain is the ratio of the feedback to the input resistor.

9.3.2 Power-Down Control Pin ($\overline{\text{PD}}$)

The LMH5485-SEP includes a power-down control pin, $\overline{\text{PD}}$. This pin must be asserted high for correct amplifier operation. The $\overline{\text{PD}}$ pin cannot be floated because there is no internal pullup or pulldown resistor on this pin to reduce disabled power consumption. Asserting this pin low (within 0.7 V of the negative supply) puts the LMH5485-SEP into a very low quiescent state (approximately 2 μA). Switches in the default V_{OCM} resistor string open to eliminate the fixed bias current (25 μA) across the supply in this 200-k Ω voltage divider to mid-supply.

9.3.2.1 Operating the Power Shutdown Feature

When the $\overline{\text{PD}}$ pin is asserted high, close to the positive supply, the device will be in normal active mode of operation. To disable the device for reduced power consumption, $\overline{\text{PD}}$ pin must be asserted low, close to the negative supply.  7-22 shows the $\overline{\text{PD}}$ pin voltage and the corresponding quiescent current drawn. For applications that require the device to only be powered on when the supplies are present, tie the $\overline{\text{PD}}$ pin to the positive supply voltage.

The disable operation is referenced from the negative supply (normally, ground). For split-supply operation, with the negative supply below ground, a disable control voltage below ground is required to turn the LMH5485-SEP off when the negative supply exceeds - 0.7 V.

For single-supply operation, a minimum of 1.7 V above the negative supply (ground, in this case) is required to assure operation. This minimum logic-high level allows for direct operation from 1.8 V supply logic.

9.3.3 Input Overdrive Operation

The LMH5485-SEP input stage architecture is intrinsically robust to input overdrives with the series input resistor required by all applications. High input overdrives cause the outputs to limit into their maximum swings with the remaining input current through the R_g resistors absorbed by internal, back-to-back protection diodes across the two inputs. These diodes are normally off in application, and only turn on to absorb the currents that a large input overdrive might produce through the source impedance and or the series R_g elements required by all designs.

The internal input diodes can safely absorb up to ± 15 mA in an overdrive condition. For designs that require more current to be absorbed, consider adding an external protection diode such as BAV99.

9.4 Device Functional Modes

This wideband FDA requires external resistors for correct signal-path operation. When configured for the desired input impedance and gain setting with these external resistors, the amplifier can be either *on* with the $\overline{\text{PD}}$ pin asserted to a voltage greater than $(V_s -) + 1.7 \text{ V}$ or turned *off* by asserting $\overline{\text{PD}}$ low. Disabling the amplifier shuts off the quiescent current and stops the correct amplifier operation. The signal path is still present for the source signal through the external resistors.

The V_{OCM} control pin sets the output average voltage. Left open, V_{OCM} defaults to an internal mid-supply value. Driving this high-impedance input with a voltage reference within its valid range sets a target for the internal V_{cm} error amplifier.

9.4.1 Operation from Single-Ended Sources to Differential Outputs

One of the most useful features supported by the FDA device is an easy conversion from a single-ended input to a differential output centered on a user-controlled, common-mode level. While the output side is relatively straightforward, the device input pins move in a common-mode sense with the input signal. This common-mode voltage at the input pins moving with the input signal acts to increase the apparent input impedance to be greater than the R_g value. This input active impedance issue applies to both AC- and DC-coupled designs, and requires somewhat more complex solutions for the resistors to account for this active impedance, as shown in the following subsections.

9.4.1.1 AC-Coupled Signal Path Considerations for Single-Ended Input to Differential Output Conversion

When the signal path can be AC-coupled, the DC biasing for the LMH5485-SEP becomes a relatively simple task. In all designs, start by defining the output common-mode voltage. The AC-coupling issue can be separated for the input and output sides of an FDA design. In any case, the design starts by setting the desired V_{OCM} . When an AC-coupled path follows the output pins, the best linearity is achieved by operating V_{OCM} at mid-supply. The V_{OCM} voltage must be within the linear range for the common-mode loop, as specified in the headroom specifications (approximately 0.91 V greater than the negative supply and 1.1 V less than the positive supply). If the output path is also AC coupled, simply letting the V_{OCM} control pin float is usually preferred in order to get a mid-supply default V_{OCM} bias with minimal elements. To limit noise, place a 0.1 μF decoupling capacitor on the V_{OCM} pin to ground.

After V_{OCM} is defined, check the target output voltage swing to ensure that the V_{OCM} plus the positive or negative output swing on each side does not clip into the supplies. Check that $V_{\text{OCM}} \pm V_p$ does not exceed the absolute supply rails for this rail-to-rail output (RRO) device.

Going to the device input pins side, because both the source and balancing resistor on the nonsignal input side are DC blocked (see [Figure 8-1](#)), no common-mode current flows from the output common-mode voltage, thus setting the input common-mode equal to the output common-mode voltage.

This input headroom also sets a limit for higher V_{OCM} voltages. Because the input V_{cm} is the output V_{OCM} for AC-coupled sources, the 1.2 V minimum headroom for the input pins to the positive supply overrides the 1.1 V headroom limit for the output V_{OCM} . The input signal also moves this input V_{cm} around the DC bias point.

9.4.1.2 DC-Coupled Input Signal Path Considerations for Single-Ended to Differential Conversion

The output considerations remain the same as for the AC-coupled design. Again, the input can be DC-coupled while the output is AC-coupled. A DC-coupled input with an AC-coupled output might have some advantages to move the input V_{icm} down if the source is ground referenced. 图 8-2 shows how when the source is DC-coupled into the LMH5485-SEP, both sides of the input circuit must be DC coupled to retain differential balance. Normally, the nonsignal input side has an R_g element biased to whatever the source midrange is expected to be. Providing this midscale reference gives a balanced differential swing around V_{OCM} at the outputs.

One significant consideration for a DC-coupled input is that V_{OCM} sets up a common-mode bias current from the output back through R_f and R_g to the source on both sides of the feedback. Without input balancing networks, the source must sink or source this DC current. After the input signal range and biasing on the other R_g element is set, check that the voltage divider from V_{OCM} to V_{in} through R_f and R_g (and possibly R_s) establishes an input V_{icm} at the device input pins that is in range. If the average source is at ground, the negative rail input stage for the LMH5485-SEP is in range for applications using a single positive supply and a positive output V_{OCM} setting because this DC current lifts the average FDA input summing junctions up off of ground to a positive voltage (the average of the V_+ and V_- input pin voltages on the FDA).

9.4.2 Differential-Input to Differential-Output Operation

In many ways, this method is a much simpler way to operate the FDA from a design equations perspective. Assuming the two sides of the circuit are balanced with equal R_f and R_g elements, the differential input impedance is the sum of the two R_g elements to a differential inverting summing junction. In these designs, the input common-mode voltage at the summing junctions does not move with the signal, but must be DC biased in the allowable range for the input pins with consideration given to the voltage headroom required from each supply. Slightly different considerations apply to AC- or DC-coupled, differential-in to differential-out designs, as described in the following sections.

9.4.2.1 AC-Coupled, Differential-Input to Differential-Output Design Issues

There are two typical ways to use the LMH5485-SEP with an AC-coupled differential source. In the first method, the source is differential and can be coupled in through two blocking capacitors. The second method uses either a single-ended or a differential source and couples in through a transformer (or balun). 图 9-1 shows a typical blocking capacitor approach to a differential input. An optional input differential termination resistor (R_m) is included in this design. This R_m element allows the input R_g resistors to be scaled up while still delivering lower differential input impedance to the source. In this example, the R_g elements sum to show a $200\ \Omega$ differential impedance, while the R_m element combines in parallel to give a net $100\ \Omega$, AC-coupled, differential impedance to the source. Again, the design proceeds ideally by selecting the R_f element values, then the R_g to set the differential gain, then an R_m element (if needed) to achieve a target input impedance. Alternatively, the R_m element can be eliminated, the R_g elements set to the desired input impedance, and R_f set to the get the differential gain ($= R_f / R_g$).



图 9-1. Down-Converter Mixer Delivering an AC-Coupled Differential Signal to the LMH5485-SEP

The DC biasing here is very simple. The output V_{OCM} is set by the input control voltage. Because there is no DC current path for the output common-mode voltage, that DC bias also sets the input pins common-mode operating points.

Transformer input coupling allows either a single-ended or differential source to be coupled into the LMH5485-SEP, which also improves the input-referred noise figure. These designs assume a source impedance that must be matched in the balun interface. [Figure 9-2](#) shows the simplest approach where an example 1:2 turns ratio step-up transformer is used from a $50\ \Omega$ source.

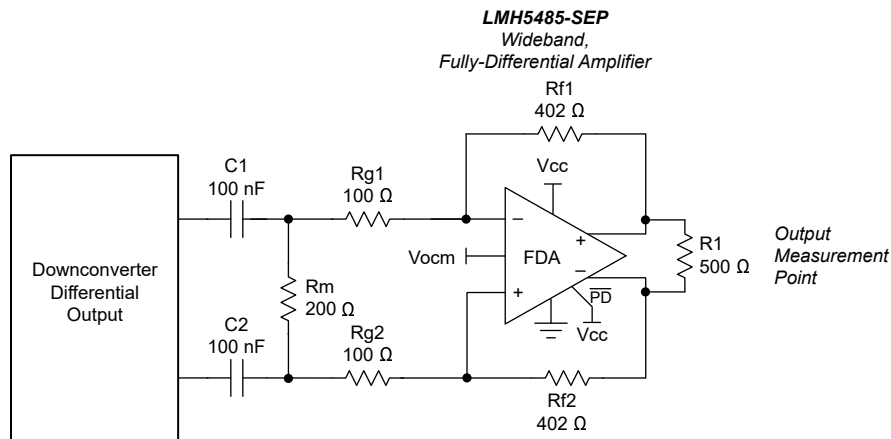
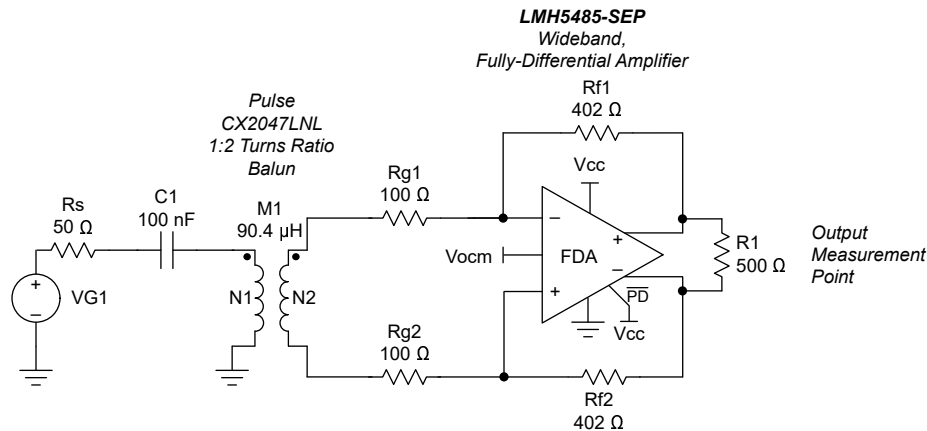

Figure 9-2. Input Balun Interface Delivers a Differential Input to the LMH5485-SEP

In this example, this 1:2 turns ratio step-up transformer provides a source and load match from the $50\ \Omega$ source if the secondary is terminated in $200\ \Omega$ (turns-ratio squared is the impedance ratio across a balun). The two R_g elements provide that termination as they sum to the differential virtual ground at the FDA summing junctions. The input blocking cap (C_1) is optional and included only to eliminate DC shorts to ground from the source. This solution often improves the total noise figure compared to using just the FDA, as it allows for the noise gain of the amplifier to be reduced.

9.4.2.2 DC-Coupled, Differential-Input to Differential-Output Design Issues

Operating the LMH5485-SEP with a DC-coupled differential input source is very simple and only requires that the input pins stay in range of the DC common-mode operating voltage. One example is a DC-to-50 MHz quadrature down-converter output. These outputs typically sit on a DC level with some internal source impedance to the external loads. The example of [Figure 9-3](#) shows a design using the LMH5485-SEP with a simple, passive RLC filter to the inputs (the R_g elements act as the differential termination for the filter design). From the original source behind the internal $250\ \Omega$ outputs, this circuit is a gain of 1 to the LMH5485-SEP output pins. The DC common-mode operating voltage level shifts from the $1.2\ \text{V}$ internal, to the mixer, to an output at the ADC V_{cm} voltage of $0.95\ \text{V}$. In this case, a simple average of the two DC voltages in the gain of 1 stage gives a $1.08\ \text{V}$ input pin common-mode result that is well within range.



图 9-3. Example DC-Coupled, Differential I/O Design from a Quadrature Mixer to an ADC

10 Application and Implementation

备注

以下应用部分中的信息不属于 TI 器件规格的范围，TI 不担保其准确性和完整性。TI 的客户应负责确定器件是否适用于其应用。客户应验证并测试其设计，以确保系统功能。

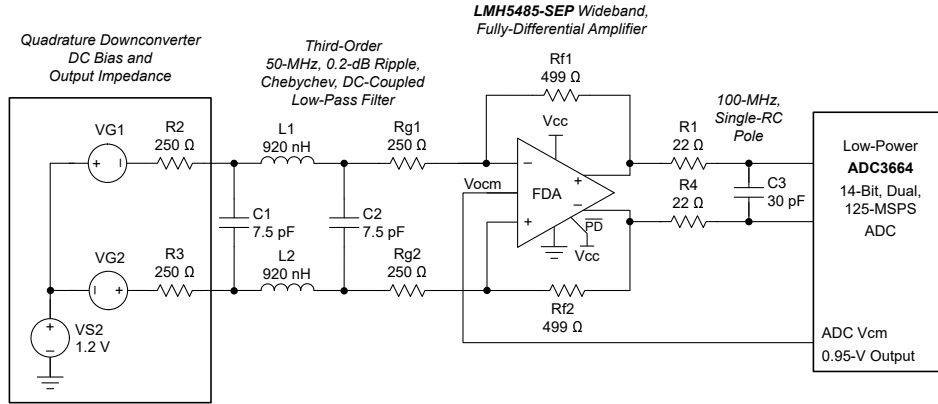
10.1 Application Information

The LMH5485-SEP offers an effective solution over a broad range of applications. Two examples are developed here. First, an attenuator stage that directly receives a higher input signal voltage and translates it to a lower differential swing on a fixed common-mode is shown. This design requires some attention to frequency-response flatness issues, and one approach to managing these issues is shown. The second example is a gain of 2 V/V, matched input of 50 Ω to an output set to 0.95 V common-mode followed by a third-order Bessel filter with approximately 20 MHz of bandwidth, designed for interfacing with a high-speed ADC.

10.2 Typical Applications

10.2.1 Designing Attenuators



图 10-1. Divide-by-10 Attenuator Application for the LMH5485-SEP

10.2.1.1 Design Requirements

In this design, the aim is to do the following:

1. Present a 4 k Ω input impedance to a ± 40 V input signal (maximum ± 10 mA from the prior stage).
2. Attenuate that swing by a factor 1/10 (- 20 dB) to a differential output swing.
3. Place that swing on a 2.5 V common-mode voltage at the LMH5485-SEP outputs.
4. Operate on a single + 5 V supply and ground.
5. Tune the frequency response to a flat Butterworth response with external capacitors.

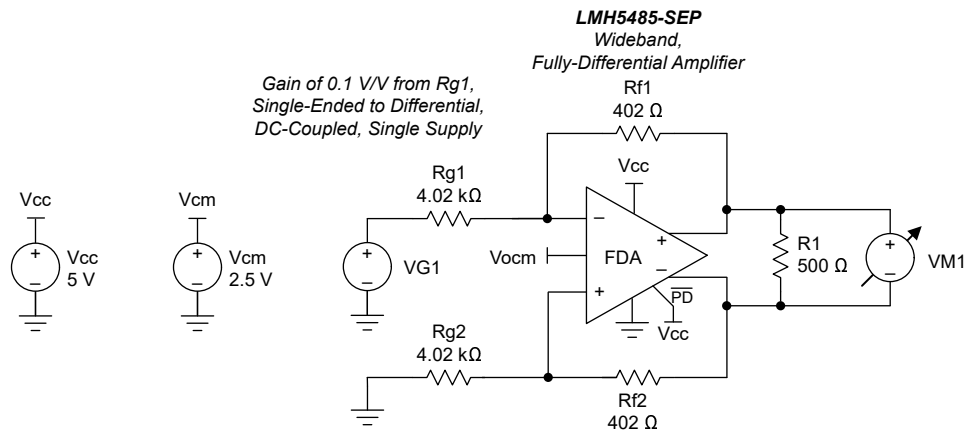
10.2.1.2 Detailed Design Procedure

Operating the LMH5485-SEP at a low DC noise gain, or with higher feedback resistors, can cause a lower phase margin to exist, giving the response peaking shown in [图 10-3](#) for the gain of 0.1 (a 1/10 attenuator) condition. Although it is often useful operating the LMH5485-SEP as an attenuator (taking a large input range to a purely differential signal around a controlled-output, common-mode voltage), the response peaking illustrated in [图 10-3](#) is usually undesirable. Several methods can be used to reduce or eliminate this peaking; usually, at the cost of higher output noise. Using DC techniques always increases the output noise broadband, while using an ac noise-gain-shaping technique peaks the noise, but only at higher frequencies that can then be filtered off with the typical passive filters often used after this stage. [图 10-1](#) shows a simplified schematic for the gain of 0.1 V/V test from [图 8-1](#).

This configuration simulates to a nominal 18° phase margin; therefore, a very highly-peaked response is shown in [图 10-3](#). This peaking can be eliminated by placing two feedback capacitors across the Rf elements and a differential input capacitor. Adding these capacitors provides a transition from a resistively set noise gain to a capacitive divider at high-frequency flattening out to a higher noise gain (NG2 here). The key for this approach is to target a Zo, where the noise gain begins to peak up. Using only the following terms, and targeting a closed-loop flat (Butterworth) response, gives this solution sequence for Zo and then the capacitor values.

1. Gain bandwidth product in Hz (850 MHz for the LMH5485-SEP)
2. Low frequency noise gain, NG1 (= 1.1 in the attenuator gain of 0.1 V/V design)
3. Target high-frequency noise gain selected to be higher than NG1 (NG2 = 3.1 V/V is selected for this design)
4. Feedback resistor value, Rf (assumed balanced for this differential design = 402 Ω for this design example)

From these elements, for any decompensated voltage-feedback op amp or FDA, solve for Zo (in Hz) using [方程式 1](#):

$$Z_o = \frac{GBP}{NG1^2} \left(1 - \frac{NG1}{NG2} - \sqrt{1 - 2 \frac{NG1}{NG2}} \right) \quad (1)$$

From this target zero frequency in the noise gain, solve for the feedback capacitors using [方程式 2](#):

$$C_f = \frac{1}{2\pi \cdot R_f \cdot Z_o \cdot NG2} \quad (2)$$

The next step is to resolve the input capacitance on the summing junction. [方程式 3](#) is for a single-ended op amp where that capacitor goes to ground. To use [方程式 3](#) for a voltage-feedback FDA, cut the target value in half, and place the result across the two inputs (reducing the external value by the specified internal differential capacitance).

$$C_s = (NG2 - 1)C_f \quad (3)$$

Setting the external compensation elements using [方程式 1](#) to [方程式 3](#) allows an estimate of the resulting flat bandwidth f_{-3dB} frequency, as shown in [方程式 4](#):

$$f_{-3dB} \approx \sqrt{GBP \cdot Z_o} \quad (4)$$

Running through these steps for the LMH5485-SEP in the attenuator circuit of [图 10-1](#) gives the proposed compensation of [图 10-2](#) where [方程式 4](#) estimates a bandwidth of 252 MHz (Zo target is 74.7 MHz).



图 10-2. Compensated Attenuator Circuit Using the LMH5485-SEP

The 1 pF across the inputs is really a total 1.9 pF, including the internal differential capacitance. These two designs (with and without the capacitors) were both bench tested and simulated using the LMH5485-SEP TINA model giving the results of [图 10-3](#).

This method does a good job of flattening the response for what starts out as a low phase-margin attenuator application. The simulation model does a very good job of predicting the peaking and showing the same improvement with the external capacitors; both giving a flat, approximately 250 MHz, closed-loop bandwidth for this gain of a 0.1 V/V design. In this example, the output noise begins to peak up (as a result of the noise-gain shaping of the capacitors) above 70 MHz. Use postfiltering to minimize any increase in the integrated noise using this technique. Using this solution to deliver an 8 V_{PP} differential output to a successive approximation register (SAR) ADC (using the 2.5 V V_{OCM} shown), the circuit accepts up to ±40 V inputs, where the 4 kΩ input Rg1 draws ±10 mA from the source.

10.2.1.3 Application Curve

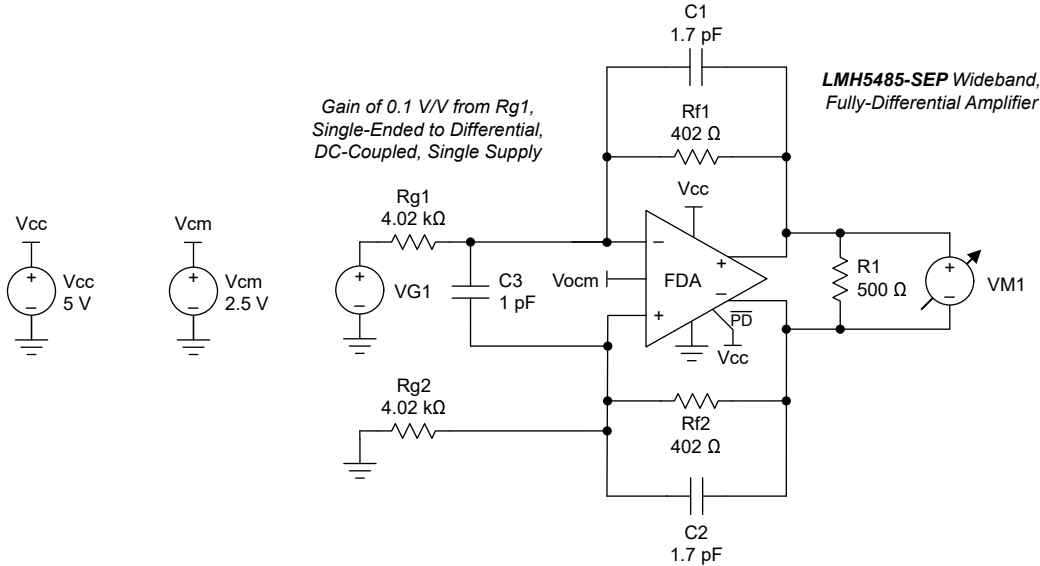

图 10-3. Attenuator Response Shapes with and without External Compensation

10.2.2 Interfacing to High-Performance ADCs

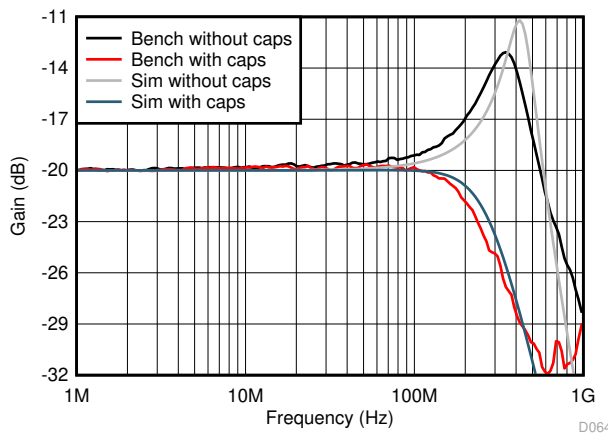

图 10-4. DC-Coupled, Bipolar Input Gain of 2 V/V Single-Ended to Differential Interface to ADC

10.2.2.1 Design Requirements

In this example design, an impedance matched input assuming a 50 Ω source is implemented with a DC-coupled gain of 2 V/V to the ADC. This configuration effectively reduces the required full-scale input to ± 0.5 V for a 2 V_{PP} full-scale input ADC. Add a low insertion-loss interstage filter to the ADC to control the broadband noise where the goal is to show minimal SNR reduction in the FFT, as well as minimal degradation in SFDR performance.

10.2.2.2 Detailed Design Procedure

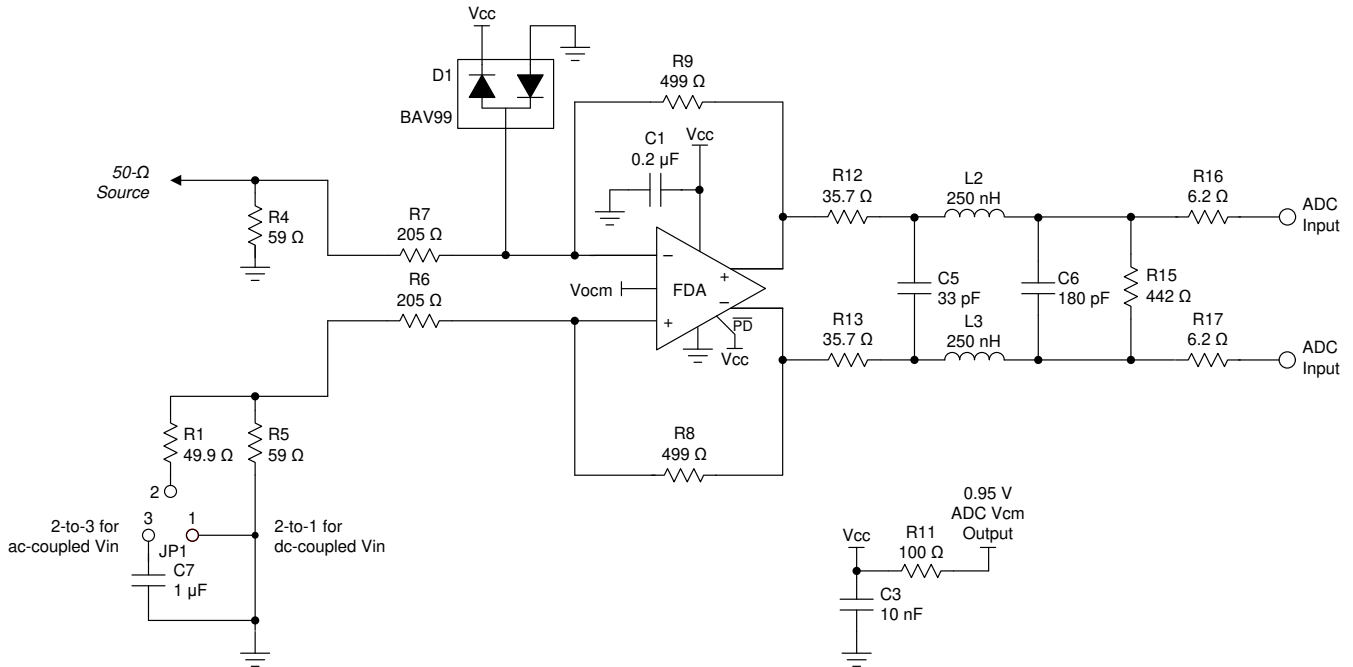
The LMH5485-SEP provides a simple interface to a wide variety of precision SAR, $\Delta \Sigma$, or higher-speed pipeline ADCs. To deliver the exceptional distortion at the output pins, considerably wider bandwidth than typically required in the signal path to the ADC inputs is provided by the LMH5485-SEP. For instance, the gain of 2 single-ended to differential design example provides approximately a 500 MHz, small-signal bandwidth. Even if the source signal is Nyquist bandlimited, this broad bandwidth can possibly integrate enough LMH5485-SEP noise to degrade the SNR through the ADC if the broadband noise is not bandlimited between the amplifier and ADC. 图 10-4 shows an example DC-coupled, gain of 2 interface with a controlled, interstage-bandwidth filter.

Designed for a DC-coupled 50 Ω input match, this design starts with a 499 Ω feedback resistor, and provides a gain of 2.35 V/V to the LMH5485-SEP output pins. The third-order interstage, low-pass filter provides a 20 MHz Bessel response with a 0.85 V/V insertion loss to the ADC, providing a net gain of 2 V/V from board edge to the ADC inputs. Although the LMH5485-SEP can absorb overdrives, an external protection element is added using the BAV99 low-capacitance device, shown in 图 10-4. For DC-coupled testing, pins 1 and 2 of JP1 are jumpered together. When the source is an AC-coupled, 50 Ω source, pins 2 and 3 of JP1 are jumpered to maintain differential balance.

11 Power Supply Recommendations

The LMH5485-SEP is principally intended to operate with a nominal single-supply voltage of +3 V to +5 V. Supply decoupling is required, as described in the [Layout Guidelines](#). The amplifier signal path is flexible for single or split-supply operation. Most applications are intended to be single supply, but any split-supply design can be used, as long as the total supply across the LMH5485-SEP is less than 5.25 V and the required input, output, and common-mode pin headrooms to each supply are observed. Left open, the V_{OCM} pin defaults to near mid-supply for any combination of split or single supplies used. The disable pin is negative-rail referenced. Using a negative supply requires the disable pin to be pulled down to within 0.7 V of the negative supply to disable the amplifier.

12 Layout

12.1 Layout Guidelines

Similar to all high-speed devices, best system performance is achieved with a close attention to board layout. The LMH5485-SEP evaluation module (EVM) shows a good example of high frequency layout techniques as a reference. This EVM includes numerous extra elements and features for characterization purposes that may not apply to some applications. General high-speed, signal-path layout suggestions include the following:

- Continuous ground planes are preferred for signal routing with matched impedance traces for longer runs; however, ground and power planes around the capacitive sensitive input and output device pins should be open. After the signal is sent into a resistor, the parasitic capacitance becomes more of a band limiting issue and less of a stability issue.
- Use good, high-frequency decoupling capacitors (0.1 μF) on the ground plane at the device power pins. Higher value capacitors (2.2 μF) are required, but may be placed further from the device power pins and shared among devices. A supply decoupling capacitor across the two power supplies (for bipolar operation) should also be added. For best high-frequency decoupling, consider X2Y supply-decoupling capacitors that offer a much higher self-resonance frequency over standard capacitors.
- For each LMH5485-SEP, attach a separate 0.1 μF capacitor to a nearby ground plane. With cascaded or multiple parallel channels, including ferrite beads from the larger capacitor is often useful to the local high-frequency decoupling capacitor.
- When using differential signal routing over any appreciable distance, use microstrip layout techniques with matched impedance traces.
- The input summing junctions are very sensitive to parasitic capacitance. Connect any R_g elements into the summing junction with minimal trace length to the device pin side of the resistor. The other side of the R_g elements can have more trace length if needed to the source or to ground.

13 Device and Documentation Support

13.1 Documentation Support

13.1.1 Related Documentation

For related documentation see the following:

- Texas Instruments, [Design for a Wideband, Differential Transimpedance DAC Output application report](#)
- Texas Instruments, [Extending Rail-to-Rail Output Range for Fully Differential Amplifiers to Include True Zero Volts reference guide](#)
- Texas Instruments, [LMH6554 2.8-GHz Ultra Linear Fully Differential Amplifier data sheet](#)
- Texas Instruments, [Maximizing the dynamic range of analog front ends having a transimpedance amplifier technical brief](#)
- Texas Instruments, [Fully Differential Amplifiers application note](#)
- Texas Instruments, [Maximizing Signal Chain Distortion Performance Using High Speed Amplifiers application note](#)
- Texas Instruments, [TI Precision Labs - Fully Differential Amplifiers video series](#)

13.2 Receiving Notification of Documentation Updates

To receive notification of documentation updates, navigate to the device product folder on ti.com. In the upper right corner, click on *Alert me* to register and receive a weekly digest of any product information that has changed. For change details, review the revision history included in any revised document.

13.3 支持资源

TI E2E™ 支持论坛是工程师的重要参考资料，可直接从专家获得快速、经过验证的解答和设计帮助。搜索现有解答或提出自己的问题可获得所需的快速设计帮助。

链接的内容由各个贡献者“按原样”提供。这些内容并不构成 TI 技术规范，并且不一定反映 TI 的观点；请参阅 TI 的《使用条款》。

13.4 Trademarks

TI E2E™ is a trademark of Texas Instruments.
所有商标均为其各自所有者的财产。

13.5 Electrostatic Discharge Caution



This integrated circuit can be damaged by ESD. Texas Instruments recommends that all integrated circuits be handled with appropriate precautions. Failure to observe proper handling and installation procedures can cause damage.

ESD damage can range from subtle performance degradation to complete device failure. Precision integrated circuits may be more susceptible to damage because very small parametric changes could cause the device not to meet its published specifications.

13.6 术语表

TI 术语表 本术语表列出并解释了术语、首字母缩略词和定义。

14 Mechanical, Packaging, and Orderable Information

The following pages include mechanical, packaging, and orderable information. This information is the most current data available for the designated devices. This data is subject to change without notice and revision of this document. For browser-based versions of this data sheet, refer to the left-hand navigation.

PACKAGING INFORMATION

Orderable Device	Status (1)	Package Type	Package Drawing	Pins	Package Qty	Eco Plan (2)	Lead finish/ Ball material (6)	MSL Peak Temp (3)	Op Temp (°C)	Device Marking (4/5)	Samples
LMH5485DGKSEP	ACTIVE	VSSOP	DGK	8	80	RoHS & Green	NIPDAU	Level-2-260C-1 YEAR	-55 to 125	5485	Samples
PLMH5485DGKSEP	ACTIVE	VSSOP	DGK	8	80	TBD	Call TI	Call TI	-55 to 125		Samples

(1) The marketing status values are defined as follows:

ACTIVE: Product device recommended for new designs.

LIFEBUY: TI has announced that the device will be discontinued, and a lifetime-buy period is in effect.

NRND: Not recommended for new designs. Device is in production to support existing customers, but TI does not recommend using this part in a new design.

PREVIEW: Device has been announced but is not in production. Samples may or may not be available.

OBSOLETE: TI has discontinued the production of the device.

(2) **RoHS:** TI defines "RoHS" to mean semiconductor products that are compliant with the current EU RoHS requirements for all 10 RoHS substances, including the requirement that RoHS substance do not exceed 0.1% by weight in homogeneous materials. Where designed to be soldered at high temperatures, "RoHS" products are suitable for use in specified lead-free processes. TI may reference these types of products as "Pb-Free".

RoHS Exempt: TI defines "RoHS Exempt" to mean products that contain lead but are compliant with EU RoHS pursuant to a specific EU RoHS exemption.

Green: TI defines "Green" to mean the content of Chlorine (Cl) and Bromine (Br) based flame retardants meet JS709B low halogen requirements of <=1000ppm threshold. Antimony trioxide based flame retardants must also meet the <=1000ppm threshold requirement.

(3) MSL, Peak Temp. - The Moisture Sensitivity Level rating according to the JEDEC industry standard classifications, and peak solder temperature.

(4) There may be additional marking, which relates to the logo, the lot trace code information, or the environmental category on the device.

(5) Multiple Device Markings will be inside parentheses. Only one Device Marking contained in parentheses and separated by a "~" will appear on a device. If a line is indented then it is a continuation of the previous line and the two combined represent the entire Device Marking for that device.

(6) Lead finish/Ball material - Orderable Devices may have multiple material finish options. Finish options are separated by a vertical ruled line. Lead finish/Ball material values may wrap to two lines if the finish value exceeds the maximum column width.

Important Information and Disclaimer:The information provided on this page represents TI's knowledge and belief as of the date that it is provided. TI bases its knowledge and belief on information provided by third parties, and makes no representation or warranty as to the accuracy of such information. Efforts are underway to better integrate information from third parties. TI has taken and continues to take reasonable steps to provide representative and accurate information but may not have conducted destructive testing or chemical analysis on incoming materials and chemicals. TI and TI suppliers consider certain information to be proprietary, and thus CAS numbers and other limited information may not be available for release.

In no event shall TI's liability arising out of such information exceed the total purchase price of the TI part(s) at issue in this document sold by TI to Customer on an annual basis.

OTHER QUALIFIED VERSIONS OF LMH5485-SEP :

- Space : [LMH5485-SP](#)

NOTE: Qualified Version Definitions:

- Space - Radiation tolerant, ceramic packaging and qualified for use in Space-based application

重要声明和免责声明

TI“按原样”提供技术和可靠性数据（包括数据表）、设计资源（包括参考设计）、应用或其他设计建议、网络工具、安全信息和其他资源，不保证没有瑕疵且不做任何明示或暗示的担保，包括但不限于对适销性、某特定用途方面的适用性或不侵犯任何第三方知识产权的暗示担保。

这些资源可供使用 TI 产品进行设计的熟练开发人员使用。您将自行承担以下全部责任：(1) 针对您的应用选择合适的 TI 产品，(2) 设计、验证并测试您的应用，(3) 确保您的应用满足相应标准以及任何其他功能安全、信息安全、监管或其他要求。

这些资源如有变更，恕不另行通知。TI 授权您仅可将这些资源用于研发本资源所述的 TI 产品的应用。严禁对这些资源进行其他复制或展示。您无权使用任何其他 TI 知识产权或任何第三方知识产权。您应全额赔偿因在这些资源的使用中对 TI 及其代表造成的任何索赔、损害、成本、损失和债务，TI 对此概不负责。

TI 提供的产品受 [TI 的销售条款](#) 或 [ti.com](#) 上其他适用条款/TI 产品随附的其他适用条款的约束。TI 提供这些资源并不会扩展或以其他方式更改 TI 针对 TI 产品发布的适用的担保或担保免责声明。

TI 反对并拒绝您可能提出的任何其他或不同的条款。

邮寄地址：Texas Instruments, Post Office Box 655303, Dallas, Texas 75265

Copyright © 2023，德州仪器 (TI) 公司