

OPA1637 高保真、低噪声、全差分、Burr-Brown™ 音频运算放大器



1 特性

- 低输入电压噪声：1kHz 时为 $3.7\text{nV}/\sqrt{\text{Hz}}$
- 低 THD + N：1 kHz 时为 -120dB
- 低电源电流： $\pm 18\text{V}$ 下为 $950\mu\text{A}$
- 输入失调电压： $\pm 200\mu\text{V}$ (最大值)
- 输入偏置电流： 2nA (最大值)
- 低偏置电流噪声：10Hz 时为 $400\text{fA}/\sqrt{\text{Hz}}$
- 带宽增益积：9.2MHz
- 差分输出电压摆率： $15\text{V}/\mu\text{s}$
- 宽输入和输出共模范围
- 宽单电源工作电压范围：3V 至 36V
- 低电源电流断电特性： $< 20\mu\text{A}$
- 过载功率限制
- 电流限制
- 封装：8 引脚 VSSOP
- 温度范围： -40°C 至 $+125^\circ\text{C}$

2 应用

- 专业音频混合器或控制平面
- 专业麦克风和无线系统
- 专业扬声器系统
- 专业音频放大器
- 条形音箱
- 转盘
- 专业摄像机
- 吉他和乐器放大器
- 数据采集 (DAQ)

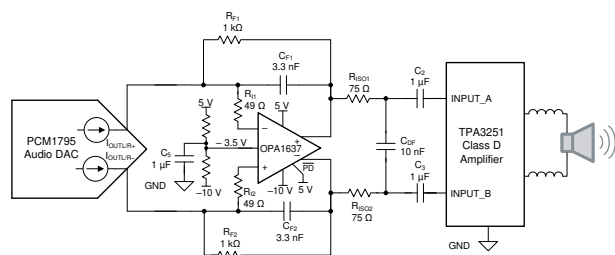

低噪声、低功耗、全差分放大器增益模块和接口

3 说明

OPA1637 是一款具有低噪声、低总谐波失真 (THD) 的全差分 Burr-Brown™ 音频运算放大器，可轻松过滤和驱动全差分信号链。

OPA1637 还可将单端信号源转换为高保真模数转换器 (ADC) 所需的差分输出。双极性超级 β 输入专为实现出色的低噪声和 THD 而设计，在非常低的静态电流和输入偏置电流下就可产生非常低的噪声系数。该器件设计用于要求低功耗、高信噪比 (SNR) 和无杂散动态范围 (SFDR) 的音频电路。

OPA1637 具有高压电源功能，支持高达 $\pm 18\text{V}$ 的电源电压。高压差分信号链可通过该功能提高裕量和动态范围，而无需为差分信号的每个极性添加单独的放大器。极低的电压和电流噪声使得 OPA1637 可以用于高增益配置，而对音频信号噪声的影响最小。

OPA1637 可在 -40°C 至 $+125^\circ\text{C}$ 的宽温度范围内工作，并采用 8 引脚 VSSOP 封装。

器件信息(1)

器件型号	封装	封装尺寸 (标称值)
OPA1637	VSSOP (8)	3.00mm × 3.00mm

(1) 如需了解所有可用封装，请参阅数据表末尾的封装选项附录。

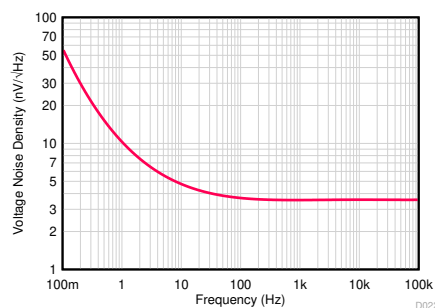

低输入电压噪声



Table of Contents

1 特性	1	8.4 Device Functional Modes.....	18
2 应用	1	9 Application and Implementation	19
3 说明	1	9.1 Application Information.....	19
4 Revision History	2	9.2 Typical Applications.....	23
5 Pin Configuration and Functions	3	10 Power Supply Recommendations	28
6 Specifications	4	11 Layout	28
6.1 Absolute Maximum Ratings.....	4	11.1 Layout Guidelines.....	28
6.2 ESD Ratings.....	4	11.2 Layout Example.....	28
6.3 Recommended Operating Conditions.....	4	12 Device and Documentation Support	29
6.4 Thermal Information.....	4	12.1 Device Support.....	29
6.5 Electrical Characteristics.....	5	12.2 Documentation Support.....	29
6.6 Typical Characteristics.....	9	12.3 接收文档更新通知.....	29
7 Parameter Measurement Information	16	12.4 支持资源.....	29
7.1 Characterization Configuration.....	16	12.5 Trademarks.....	29
8 Detailed Description	17	12.6 静电放电警告.....	29
8.1 Overview.....	17	12.7 术语表.....	29
8.2 Functional Block Diagram.....	17	13 Mechanical, Packaging, and Orderable Information	29
8.3 Feature Description.....	18		

4 Revision History

注：以前版本的页码可能与当前版本的页码不同

Changes from Revision A (May 2020) to Revision B (August 2020)	Page
• 更新了整个文档中的表格、图和交叉参考的编号格式.....	1
• 更改了首页应用图，为 R _{F1} 显示正确的标签和值.....	1
• Changed Figure 7-1 to show correct labels.....	16
• Changed Figure 9-5 to show correct label and value for R _{F1}	23
• Changed Figure 9-8 negative rail from 0 V to - 5 V.....	25

Changes from Revision * (December 2019) to Revision A (May 2020)	Page
• 将器件状态从“预告信息 (预发布)”更改为“生产数据 (正在供货)”	1

5 Pin Configuration and Functions



图 5-1. DGK Package, 8-Pin VSSOP, Top View

Pin Functions

PIN		I/O	DESCRIPTION
NAME	NO.		
IN -	1	I	Inverting (negative) amplifier input
IN+	8	I	Noninverting (positive) amplifier input
OUT -	5	O	Inverting (negative) amplifier output
OUT+	4	O	Noninverting (positive) amplifier output
PD	7	I	Power down. $\overline{\text{PD}}$ = logic low = power off mode. $\overline{\text{PD}}$ = logic high = normal operation. The logic threshold is referenced to VS+. If power down is not needed, leave $\overline{\text{PD}}$ floating.
VOCM	2	I	Output common-mode voltage control input
VS -	6	I	Negative power-supply input
VS+	3	I	Positive power-supply input

6 Specifications

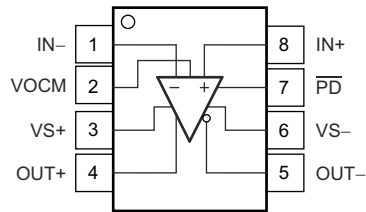
6.1 Absolute Maximum Ratings

over operating free-air temperature range (unless otherwise noted)⁽¹⁾

			MIN	MAX	UNIT
V _S	Supply voltage	Single supply		40	V
		Dual supply		±20	V
	IN+, IN-, Differential voltage ⁽²⁾			±0.5	V
	IN+, IN-, VO _{CM} , \overline{PD} , OUT+, OUT- voltage ⁽³⁾		V _{VS-} - 0.5	V _{VS+} + 0.5	V
	IN+, IN- current		- 10	10	mA
	OUT+, OUT- current		- 50	50	mA
	Output short-circuit ⁽⁴⁾			Continuous	
T _A	Operating Temperature		- 40	150	°C
T _J	Junction Temperature		- 40	175	°C
T _{stg}	Storage Temperature		- 65	150	°C

- (1) Stresses beyond those listed under *Absolute Maximum Ratings* may cause permanent damage to the device. These are stress ratings only, which do not imply functional operation of the device at these or any other conditions beyond those indicated under *Recommended Operating Conditions*. Exposure to absolute-maximum-rated conditions for extended periods may affect device reliability.
- (2) Input pins IN+ and IN- are connected with anti-parallel diodes in between the two terminals. Differential input signals that are greater than 0.5 V or less than - 0.5 V must be current-limited to 10 mA or less.
- (3) Input terminals are diode-clamped to the supply rails (V_{S+}, V_{S-}). Input signals that swing more than 0.5 V greater or less the supply rails must be current-limited to 10 mA or less.
- (4) Short-circuit to V_S / 2.

6.2 ESD Ratings

			VALUE	UNIT
V _(ESD)	Electrostatic discharge	Human body model (HBM), per ANSI/ESDA/JEDEC JS-001 ⁽¹⁾	±1000	V
		Charged device model (CDM), per JEDEC specification JESD22-C101 ⁽²⁾	±500	

- (1) JEDEC document JEP155 states that 500-V HBM allows safe manufacturing with a standard ESD control process.
- (2) JEDEC document JEP157 states that 250-V CDM allows safe manufacturing with a standard ESD control process.

6.3 Recommended Operating Conditions

over operating free-air temperature range (unless otherwise noted)

			MIN	NOM	MAX	UNIT
V _S	Supply voltage	Single-supply	3		36	V
		Dual-supply	±1.5		±18	
T _A	Specified temperature		- 40		125	°C

6.4 Thermal Information

THERMAL METRIC ⁽¹⁾		OPA1637	UNIT
		DGK (VSSOP)	
		8 PINS	
R _{θJA}	Junction-to-ambient thermal resistance	181.1	°C/W
R _{θJC(top)}	Junction-to-case (top) thermal resistance	68.3	°C/W
R _{θJB}	Junction-to-board thermal resistance	102.8	°C/W
ψ _{JT}	Junction-to-top characterization parameter	10.6	°C/W
ψ _{JB}	Junction-to-board characterization parameter	101.1	°C/W
R _{θJC(bot)}	Junction-to-case (bottom) thermal resistance	N/A	°C/W

- (1) For information about traditional and new thermal metrics, see the [Semiconductor and IC Package Thermal Metrics](#) application report.

6.5 Electrical Characteristics

at $T_A = 25^\circ\text{C}$, V_S (dual supply) = $\pm 1.5\text{ V}$ to $\pm 18\text{ V}$, $V_{\text{VOCM}} = 0\text{ V}$, input common mode voltage (V_{ICM}) = 0 V , $R_F = 2\text{ k}\Omega$, $V_{\text{PD}} = V_{\text{VS+}}$, $R_L = 10\text{ k}\Omega$ ⁽¹⁾ (unless otherwise noted)

PARAMETER		TEST CONDITIONS	MIN	TYP	MAX	UNIT
FREQUENCY RESPONSE						
SSBW	Small-signal bandwidth	V_O ⁽²⁾ = $100\text{ mV}_{\text{PP}}$, $G = -1\text{ V/V}$		7		MHz
GBP	Gain-bandwidth product	$V_O = 100\text{ mV}_{\text{PP}}$, $G = -10\text{ V/V}$		9.2		MHz
FBP	Full-power bandwidth	$V_O = -1\text{ V}_{\text{PP}}$, $G = -1\text{ V/V}$		2.5		MHz
SR	Slew rate	$G = -1$, 10-V step		15		V/ μs
	Settling time	0.1% of final value, $G = -1\text{ V/V}$, $V_O = 10\text{-V step}$		1		μs
		0.01% of final value, $G = -1\text{ V/V}$, $V_O = 10\text{-V step}$		2		
THD+N	Total harmonic distortion and noise	Differential input, $f = 1\text{ kHz}$, $V_O = 10\text{ V}_{\text{PP}}$		-120		dB
				0.0001		%
		Single-ended input, $f = 1\text{ kHz}$, $V_O = 10\text{ V}_{\text{PP}}$		-115		dB
				0.00018		%
		Differential input, $f = 10\text{ kHz}$, $V_O = 10\text{ V}_{\text{PP}}$		-112		dB
				0.00025		%
Single-ended input, $f = 10\text{ kHz}$, $V_O = 10\text{ V}_{\text{PP}}$		-107		dB		
		0.00045		%		
HD2	Second-order harmonic distortion	Differential input, $f = 1\text{ kHz}$, $V_O = 10\text{ V}_{\text{PP}}$		-126		dB
		Single-ended input, $f = 1\text{ kHz}$, $V_O = 10\text{ V}_{\text{PP}}$		-120		
HD3	Third-order harmonic distortion	Differential input, $f = 1\text{ kHz}$, $V_O = 10\text{ V}_{\text{PP}}$		-131		dB
		Single-ended input, $f = 1\text{ kHz}$, $V_O = 10\text{ V}_{\text{PP}}$		-119		
	Overdrive recovery time	$G = 5\text{ V/V}$, 2x output overdrive, dc-coupled		3.3		μs
NOISE						
e_n	Input differential voltage noise	$f = 1\text{ kHz}$		3.7		nV/ $\sqrt{\text{Hz}}$
		$f = 10\text{ Hz}$		4		
		$f = 0.1\text{ Hz to }10\text{ Hz}$		0.1		
e_i	Input current noise, each input	$f = 1\text{ kHz}$		300		fA/ $\sqrt{\text{Hz}}$
		$f = 10\text{ Hz}$		400		
		$f = 0.1\text{ Hz to }10\text{ Hz}$		13.4		
OFFSET VOLTAGE						
V_{IO}	Input-referred offset voltage			20	± 200	μV
		$T_A = -40^\circ\text{C to }+125^\circ\text{C}$			± 250	
	Input offset voltage drift	$T_A = -40^\circ\text{C to }+125^\circ\text{C}$		0.1	± 1	$\mu\text{V}/^\circ\text{C}$
PSRR	Power-supply rejection ratio			0.025	± 0.5	$\mu\text{V/V}$
		$T_A = -40^\circ\text{C to }+125^\circ\text{C}$				
INPUT BIAS CURRENT						
I_B	Input bias current			0.2	± 2	nA
		$T_A = -40^\circ\text{C to }+125^\circ\text{C}$				
	Input bias current drift	$T_A = -40^\circ\text{C to }+125^\circ\text{C}$		2	± 15	pA/ $^\circ\text{C}$
I_{OS}	Input offset current			0.2	± 1	nA
		$T_A = -40^\circ\text{C to }+125^\circ\text{C}$				
	Input offset current drift	$T_A = -40^\circ\text{C to }+125^\circ\text{C}$		1	± 10	pA/ $^\circ\text{C}$

6.5 Electrical Characteristics (continued)

at $T_A = 25^\circ\text{C}$, V_S (dual supply) = $\pm 1.5\text{ V}$ to $\pm 18\text{ V}$, $V_{\text{VOCM}} = 0\text{ V}$, input common mode voltage ($V_{\text{ICM}} = 0\text{ V}$, $R_F = 2\text{ k}\Omega$, $V_{\text{PD}} = V_{\text{VS}+}$, $R_L = 10\text{ k}\Omega$ ⁽¹⁾ (unless otherwise noted)

PARAMETER		TEST CONDITIONS	MIN	TYP	MAX	UNIT
INPUT VOLTAGE						
	Common-mode voltage	$T_A = -40^\circ\text{C}$ to $+125^\circ\text{C}$	$V_{\text{VS}-} + 1$		$V_{\text{VS}+} - 1$	V
CMRR	Common-mode rejection ratio	$V_{\text{VS}-} + 1\text{ V} \leq V_{\text{ICM}} \leq V_{\text{VS}+} - 1\text{ V}$		140		dB
		$V_{\text{VS}-} + 1\text{ V} \leq V_{\text{ICM}} \leq V_{\text{VS}+} - 1\text{ V}$, $V_S = \pm 18\text{ V}$	126	140		
		$V_{\text{VS}-} + 1\text{ V} \leq V_{\text{ICM}} \leq V_{\text{VS}+} - 1\text{ V}$, $V_S = \pm 18\text{ V}$ $T_A = -40^\circ\text{C}$ to $+125^\circ\text{C}$	120			
INPUT IMPEDANCE						
	Input impedance differential mode	$V_{\text{ICM}} = 0\text{ V}$		$1 \parallel 1$		$\text{G}\Omega \parallel \text{pF}$
OPEN-LOOP GAIN						
A_{OL}	Open-loop voltage gain	$V_S = \pm 2.5\text{ V}$, $V_{\text{VS}-} + 0.2\text{ V} < V_O < V_{\text{VS}+} - 0.2\text{ V}$	115	120		dB
		$V_S = \pm 2.5\text{ V}$, $V_{\text{VS}-} + 0.3\text{ V} < V_O < V_{\text{VS}+} - 0.3\text{ V}$, $T_A = -40^\circ\text{C}$ to $+125^\circ\text{C}$	110	120		
		$V_S = \pm 15\text{ V}$, $V_{\text{VS}-} + 0.6\text{ V} < V_O < V_{\text{VS}+} - 0.6\text{ V}$	115	120		
		$V_S = \pm 15\text{ V}$, $V_{\text{VS}-} + 0.6\text{ V} < V_O < V_{\text{VS}+} - 0.6\text{ V}$, $T_A = -40^\circ\text{C}$ to $+125^\circ\text{C}$	110	120		
OUTPUT						
	Output voltage difference from supply voltage	$V_S = \pm 2.5\text{ V}$		± 100		mV
		$V_S = \pm 2.5\text{ V}$, $T_A = -40^\circ\text{C}$ to $+125^\circ\text{C}$		± 100		
		$V_S = \pm 18\text{ V}$		± 230		
		$V_S = \pm 18\text{ V}$, $T_A = -40^\circ\text{C}$ to $+125^\circ\text{C}$		± 270		
I_{SC}	Short-circuit current			± 31		mA
C_{LOAD}	Capacitive load drive	Differential capacitive load, no output isolation resistors, phase margin = 30°		50		pF
Z_O	Open-loop output impedance	$f = 100\text{ kHz}$ (differential)		14		Ω
OUTPUT COMMON-MODE VOLTAGE (V_{OCM}) CONTROL						
	Input Voltage Range	$V_S = \pm 2.5\text{ V}$	$V_{\text{VS}-} + 1$		$V_{\text{VS}+} - 1$	
		$V_S = \pm 18\text{ V}$	$V_{\text{VS}-} + 2$		$V_{\text{VS}+} - 2$	
	Small-signal bandwidth from V _{OCM} pin	$V_{\text{VOCM}} = 100\text{ mV}_{\text{PP}}$		2		MHz
	Large-signal bandwidth from V _{OCM} pin	$V_{\text{VOCM}} = 0.6\text{ V}_{\text{PP}}$		5.7		
	Slew rate from V _{OCM} pin	$V_{\text{VOCM}} = 0.5\text{-V}$ step, rising		3.5		V/ μs
		$V_{\text{VOCM}} = 0.5\text{-V}$ step, falling		5.5		
	DC output balance	V_{VOCM} fixed midsupply ($V_O = \pm 1\text{ V}$)		78		dB
	V _{OCM} input impedance			$2.5 \parallel 1$		$\text{M}\Omega \parallel \text{pF}$
	V _{OCM} offset from mid-supply	V _{OCM} pin floating		2		mV
	V _{OCM} common-mode offset voltage	$V_{\text{VOCM}} = V_{\text{ICM}}$, $V_O = 0\text{ V}$		± 1	± 6	mV
		$V_{\text{VOCM}} = V_{\text{ICM}}$, $V_O = 0\text{ V}$, $T_A = -40^\circ\text{C}$ to $+125^\circ\text{C}$			± 10	
	V _{OCM} common-mode offset voltage drift	$V_{\text{VOCM}} = V_{\text{ICM}}$, $V_O = 0\text{ V}$, $T_A = -40^\circ\text{C}$ to $+125^\circ\text{C}$		± 20	± 60	$\mu\text{V}/^\circ\text{C}$
POWER SUPPLY						

6.5 Electrical Characteristics (continued)

at $T_A = 25^\circ\text{C}$, V_S (dual supply) = $\pm 1.5\text{ V}$ to $\pm 18\text{ V}$, $V_{VOCM} = 0\text{ V}$, input common mode voltage (V_{ICM}) = 0 V , $R_F = 2\text{ k}\Omega$, $V_{PD} = V_{VS+}$, $R_L = 10\text{ k}\Omega$ ⁽¹⁾ (unless otherwise noted)

PARAMETER		TEST CONDITIONS	MIN	TYP	MAX	UNIT
I_Q	Quiescent operating current			0.95	1.2	mA
		$T_A = -40^\circ\text{C}$ to $+125^\circ\text{C}$			1.6	

6.5 Electrical Characteristics (continued)

at $T_A = 25^\circ\text{C}$, V_S (dual supply) = $\pm 1.5\text{ V}$ to $\pm 18\text{ V}$, $V_{\text{VOCM}} = 0\text{ V}$, input common mode voltage ($V_{\text{ICM}} = 0\text{ V}$, $R_F = 2\text{ k}\Omega$, $V_{\text{PD}} = V_{\text{VS}+}$, $R_L = 10\text{ k}\Omega$ ⁽¹⁾ (unless otherwise noted)

PARAMETER		TEST CONDITIONS	MIN	TYP	MAX	UNIT
POWER DOWN						
$V_{\text{PD(HI)}}$	Power-down enable voltage	$T_A = -40^\circ\text{C}$ to $+125^\circ\text{C}$	$V_{\text{VS}+} - 0.5$			V
$V_{\text{PD(LOW)}}$	Power-down disable voltage	$T_A = -40^\circ\text{C}$ to $+125^\circ\text{C}$		$V_{\text{VS}+} - 2.0$		V
	PD bias current	$V_{\text{PD}} = V_{\text{VS}+} - 2\text{ V}$		1	2	μA
	Powerdown quiescent current			10	20	μA
	Turn-on time delay	$V_{\text{IN}} = 100\text{ mV}$, time to $V_O = 90\%$ of final value		10		μs
	Turn-off time delay	$V_{\text{IN}} = 100\text{ mV}$, time to $V_O = 10\%$ of original value		15		μs

- (1) R_L is connected differentially, from $\text{OUT}+$ to $\text{OUT}-$.
(2) V_O refers to the differential output voltage, $V_{\text{OUT}+} - V_{\text{OUT}-}$.

6.6 Typical Characteristics

at $V_S = \pm 18\text{ V}$, $T_A = 25^\circ\text{C}$, $V_{VOCM} = V_{VICM} = 0\text{ V}$, $R_F = 2\text{ k}\Omega$, $R_L = 10\text{ k}\Omega$, $V_{OUT} = 2\text{ V}_{PP}$, $G = 1\text{ V/V}$, and $V_{PD} = V_{S+}$ (unless otherwise noted)



图 6-1. Input-Referred Voltage Noise vs Frequency



图 6-2. Current Noise vs Frequency

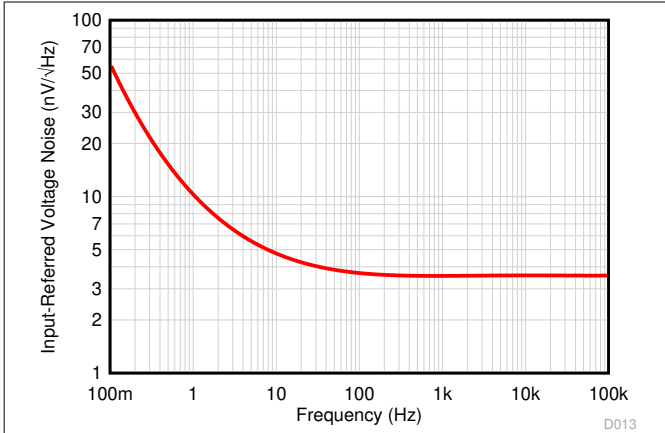

图 6-3. Total Harmonic Distortion + Noise vs Frequency

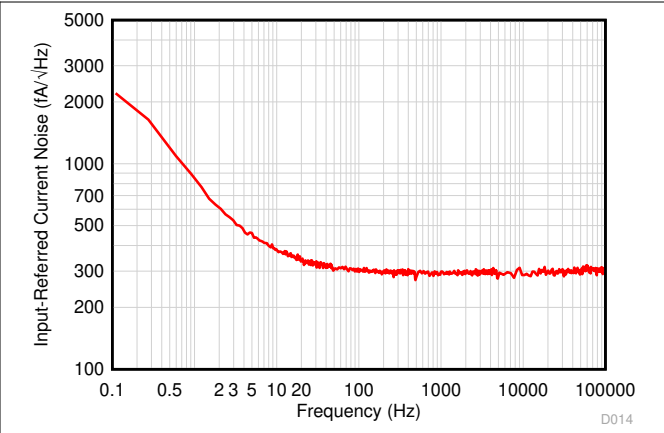

图 6-4. Total Harmonic Noise + Distortion vs Amplitude

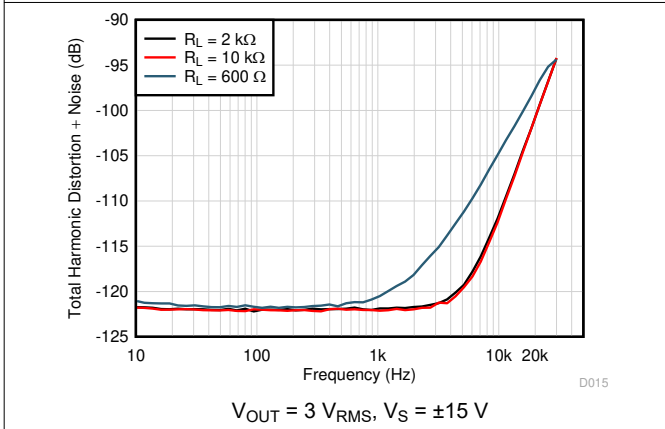

图 6-5. Open Loop Gain vs Frequency

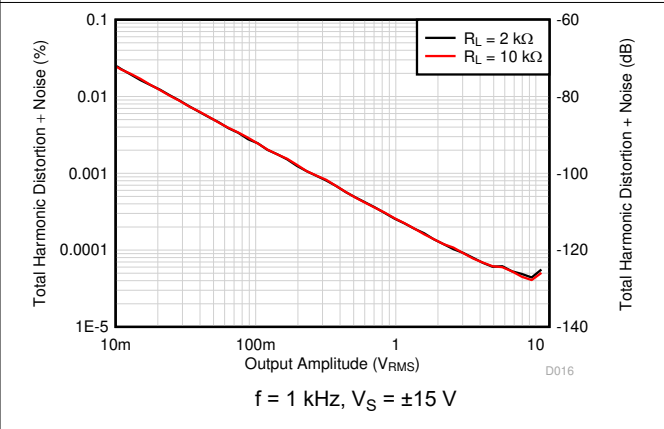

图 6-6. Closed-Loop Gain vs Frequency

6.6 Typical Characteristics (continued)

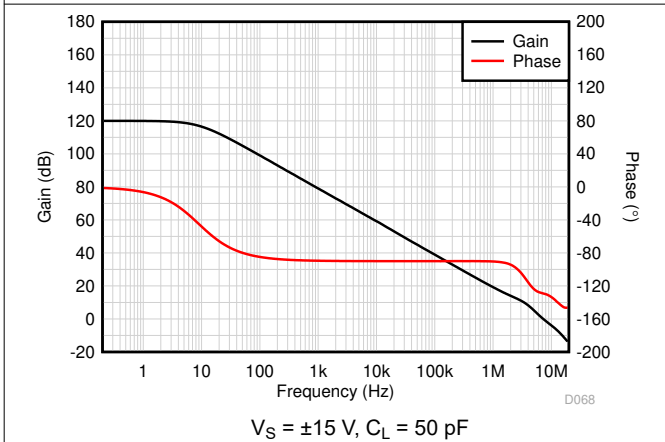
at $V_S = \pm 18\text{ V}$, $T_A = 25^\circ\text{C}$, $V_{VOCM} = V_{VICM} = 0\text{ V}$, $R_F = 2\text{ k}\Omega$, $R_L = 10\text{ k}\Omega$, $V_{OUT} = 2\text{ V}_{PP}$, $G = 1\text{ V/V}$, and $V_{PD} = V_{S+}$ (unless otherwise noted)

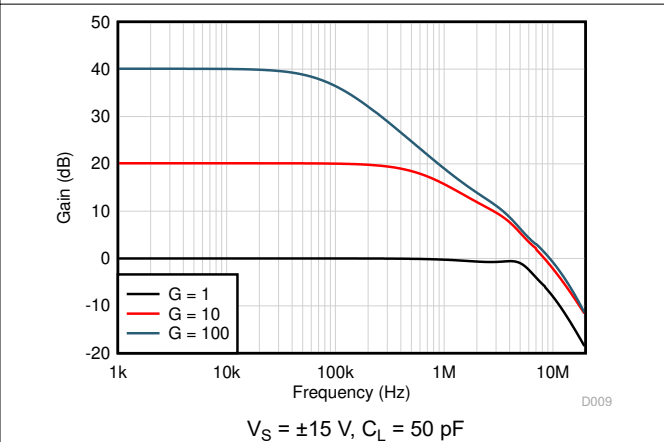

图 6-7. Common Mode Rejection Ratio vs Frequency



图 6-8. Common Mode Rejection Ratio vs Temperature

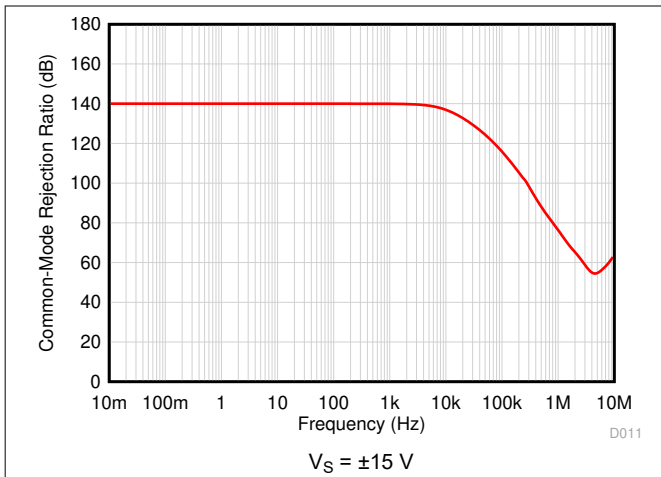

图 6-9. Power Supply Rejection Ratio vs Frequency

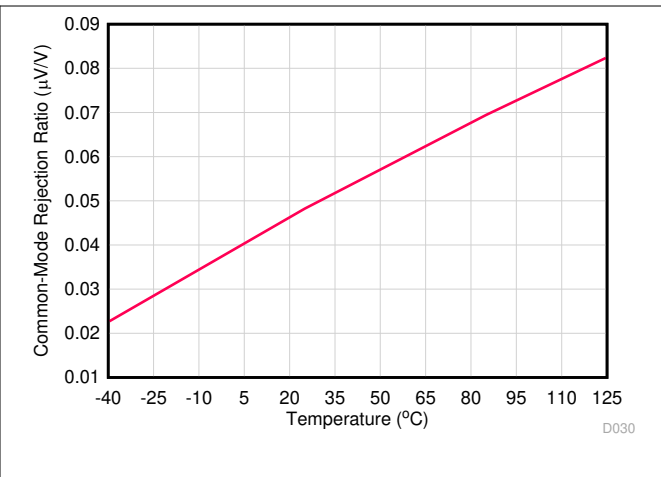

图 6-10. Power Supply Rejection Ratio vs Temperature

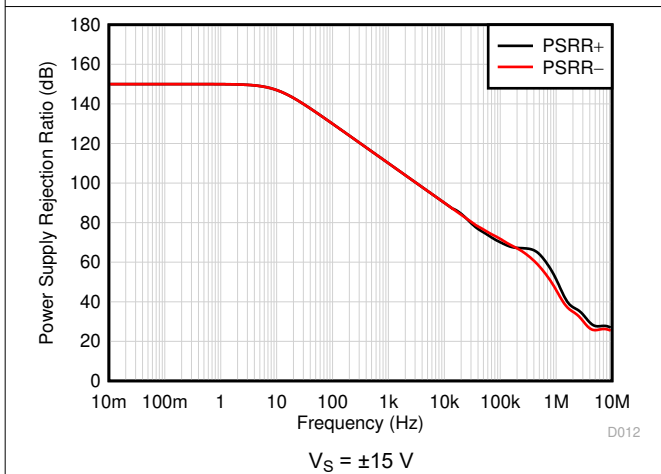

图 6-11. Maximum Output Voltage vs Frequency

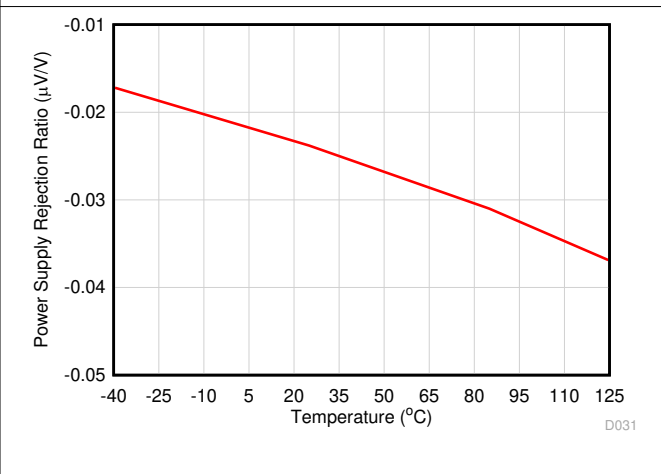

图 6-12. Output Impedance vs Frequency

6.6 Typical Characteristics (continued)

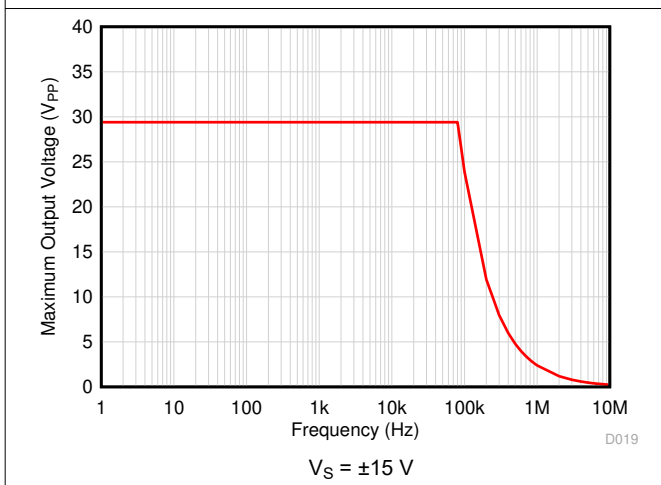
at $V_S = \pm 18\text{ V}$, $T_A = 25^\circ\text{C}$, $V_{VOCM} = V_{VICM} = 0\text{ V}$, $R_F = 2\text{ k}\Omega$, $R_L = 10\text{ k}\Omega$, $V_{OUT} = 2\text{ V}_{PP}$, $G = 1\text{ V/V}$, and $V_{PD} = V_{S+}$ (unless otherwise noted)

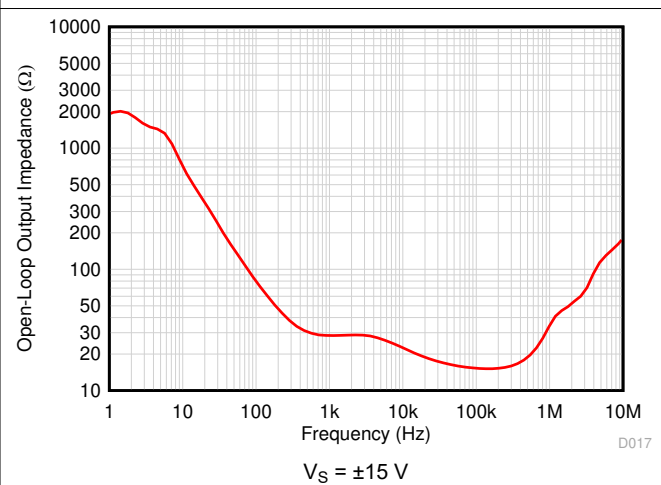

图 6-13. Input Offset Voltage Histogram



图 6-14. Input Offset Voltage Histogram

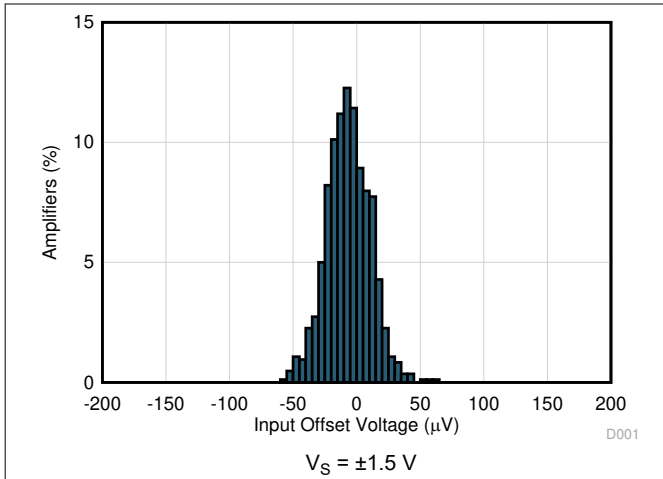

图 6-15. Input Offset Voltage Drift Histogram

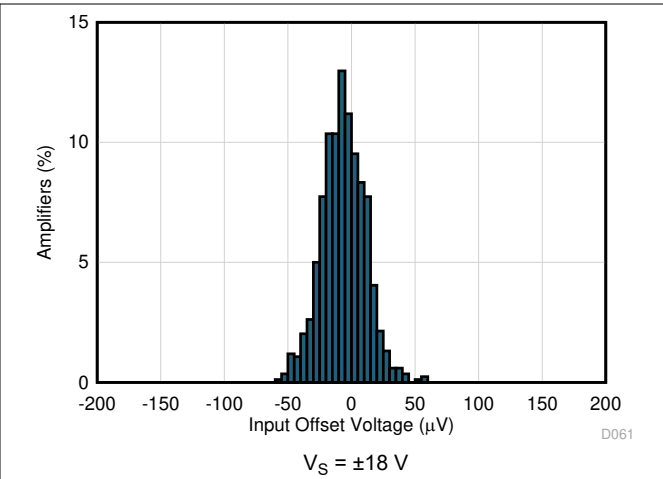

图 6-16. Output Common Mode Voltage Offset

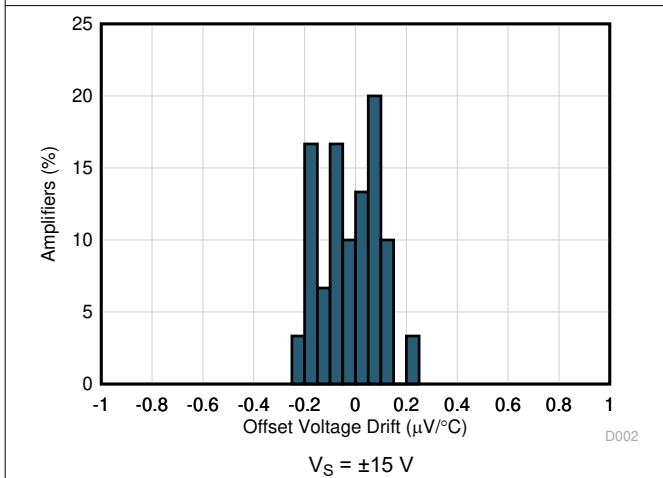

图 6-17. Output Common Mode Voltage Offset

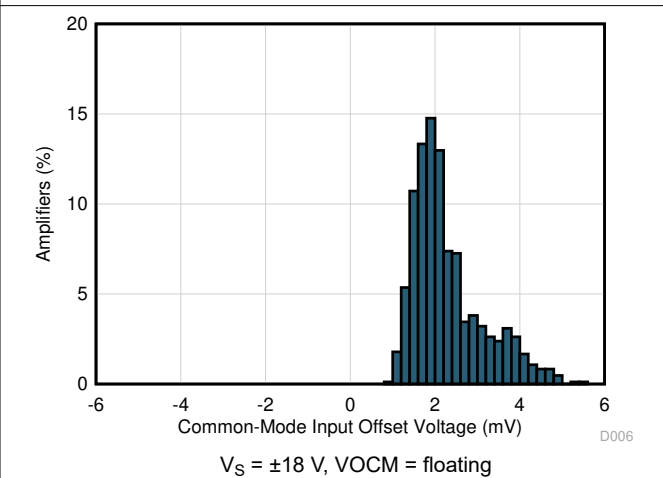

图 6-18. Quiescent Current vs Supply Voltage

6.6 Typical Characteristics (continued)

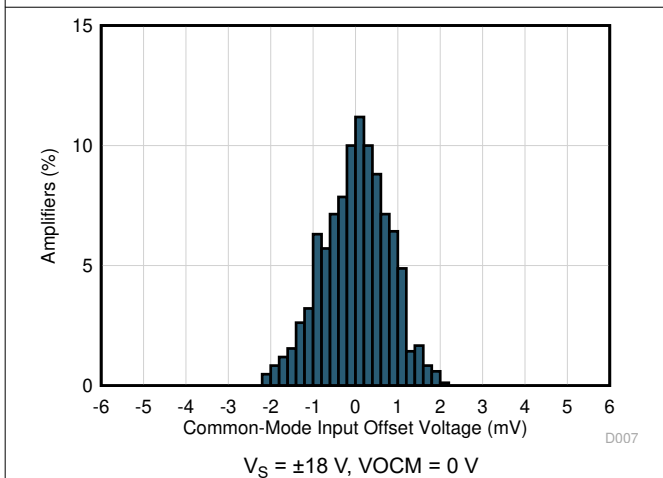
at $V_S = \pm 18\text{ V}$, $T_A = 25^\circ\text{C}$, $V_{VOCM} = V_{VICM} = 0\text{ V}$, $R_F = 2\text{ k}\Omega$, $R_L = 10\text{ k}\Omega$, $V_{OUT} = 2\text{ V}_{PP}$, $G = 1\text{ V/V}$, and $V_{PD} = V_{S+}$ (unless otherwise noted)

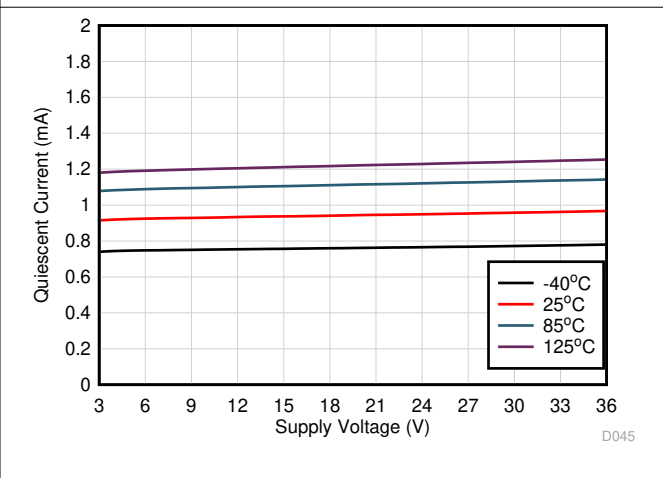

图 6-19. Quiescent Current vs Temperature



图 6-20. Quiescent Current vs Power-Down Delta from Supply Voltage

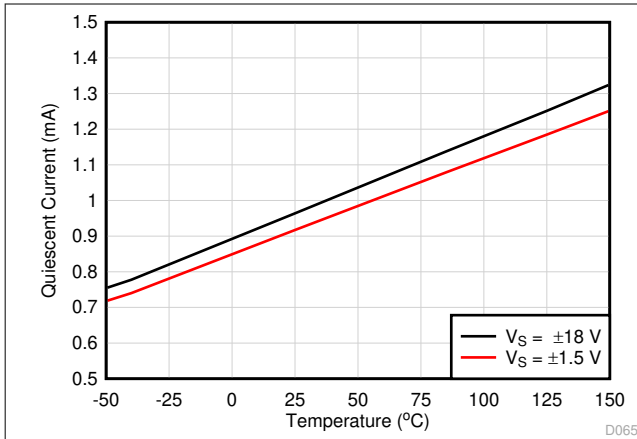

图 6-21. Input Offset Voltage vs Input Common-Mode Voltage

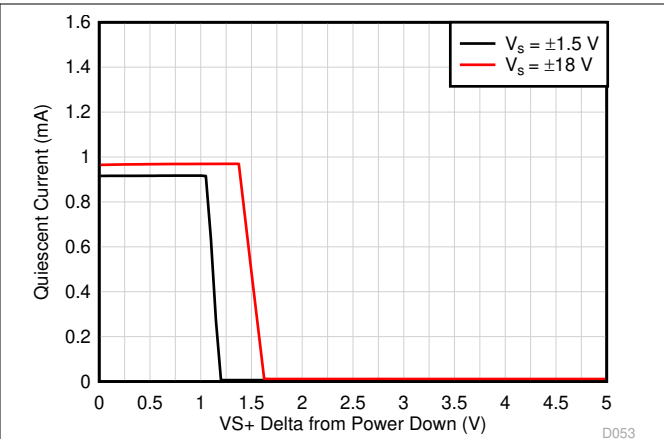

图 6-22. Input Bias Current vs Input Common-Mode Voltage

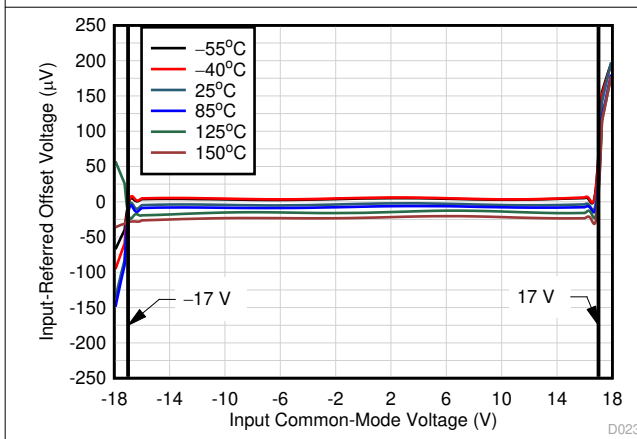

图 6-23. Input Bias Current vs Supply Voltage

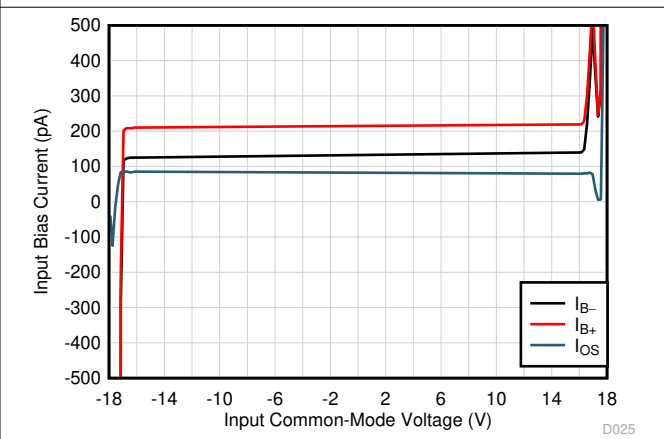

图 6-24. Output Voltage vs Output Current

6.6 Typical Characteristics (continued)

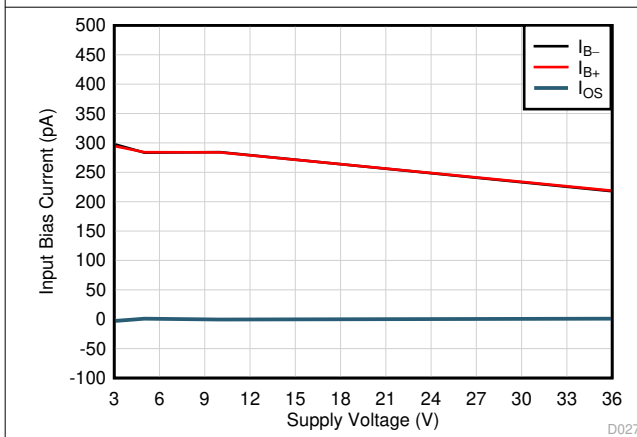
at $V_S = \pm 18\text{ V}$, $T_A = 25^\circ\text{C}$, $V_{VOCM} = V_{VICM} = 0\text{ V}$, $R_F = 2\text{ k}\Omega$, $R_L = 10\text{ k}\Omega$, $V_{OUT} = 2\text{ V}_{PP}$, $G = 1\text{ V/V}$, and $V_{PD} = V_{S+}$ (unless otherwise noted)

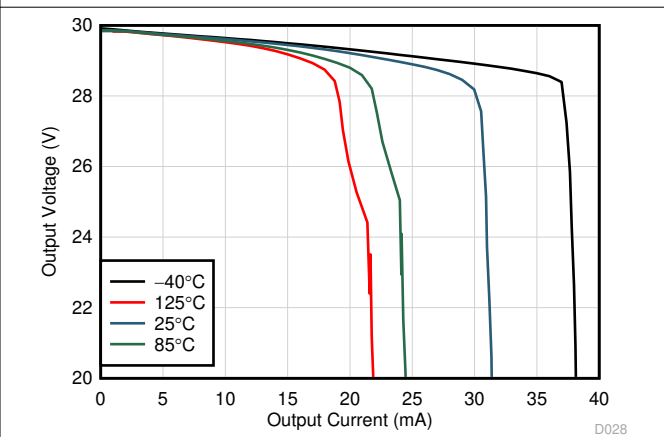

图 6-25. Output Voltage vs Output Current



图 6-26. Open-Loop Gain vs Output Delta From Supply

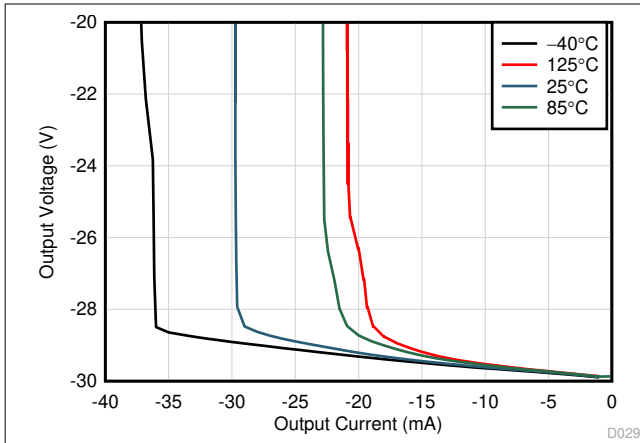

图 6-27. Small-Signal Overshoot vs Capacitive Load

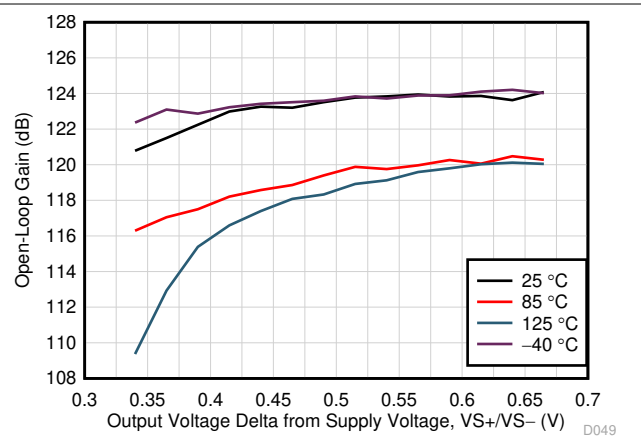

图 6-28. Small-Signal Overshoot vs Capacitive Load

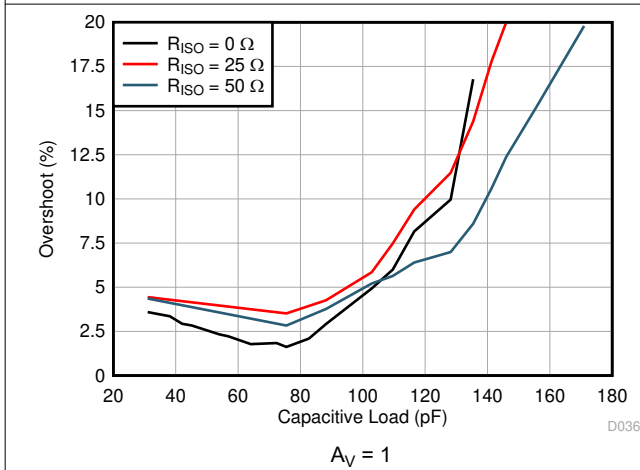

图 6-29. Output Slew Rate vs Supply Voltage

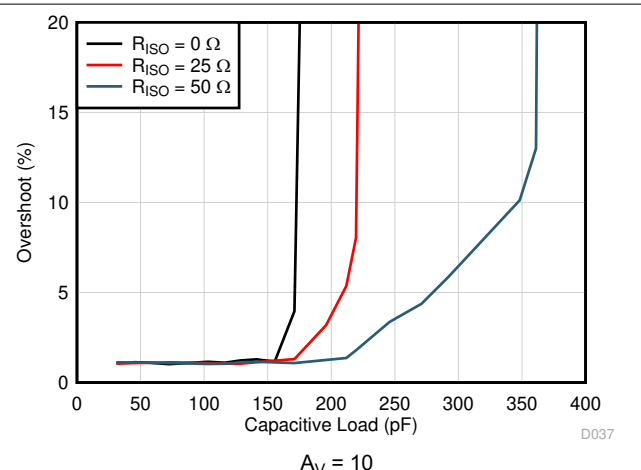

图 6-30. Short-Circuit Current vs Temperature

6.6 Typical Characteristics (continued)

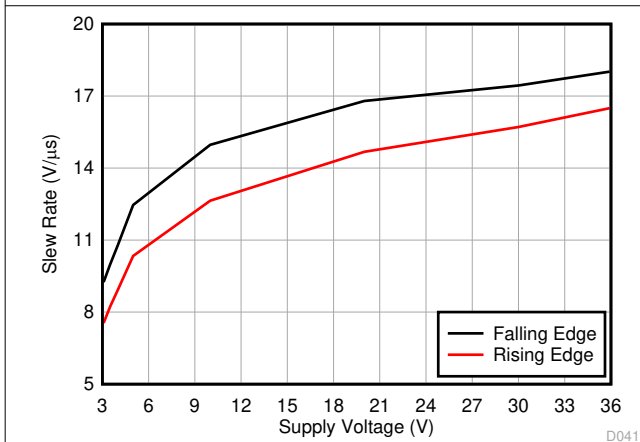
at $V_S = \pm 18\text{ V}$, $T_A = 25^\circ\text{C}$, $V_{VOCM} = V_{VICM} = 0\text{ V}$, $R_F = 2\text{ k}\Omega$, $R_L = 10\text{ k}\Omega$, $V_{OUT} = 2\text{ V}_{PP}$, $G = 1\text{ V/V}$, and $V_{PD} = V_{S+}$ (unless otherwise noted)

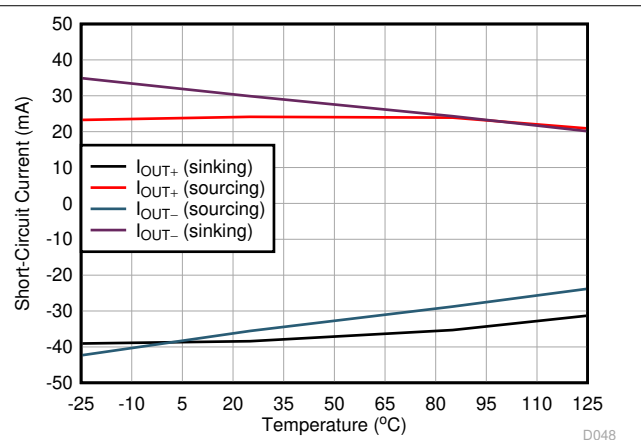

图 6-31. Large-Signal Step Response



图 6-32. Output Common-Mode Step Response, Rising

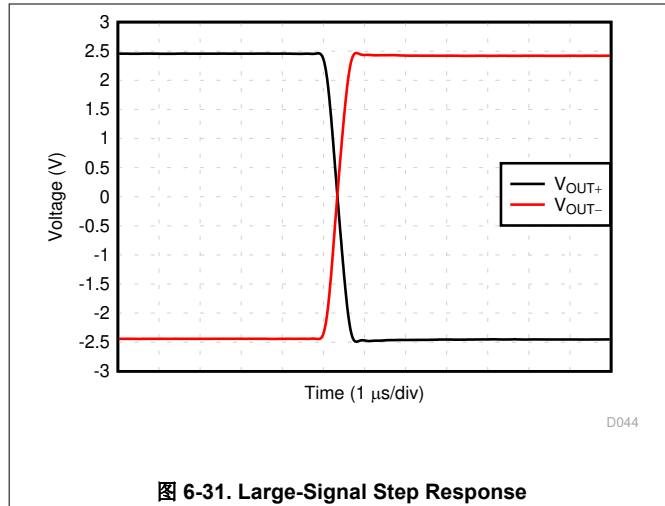

图 6-33. Output Common-Mode Step Response, Falling

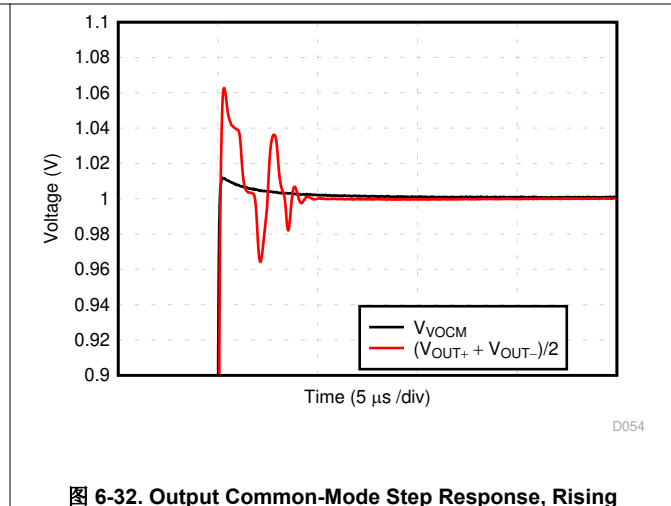

图 6-34. Small-Signal Step Response, Falling

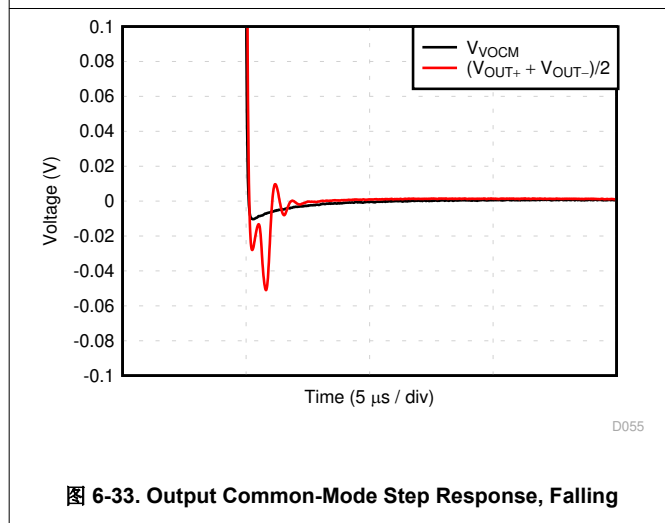

图 6-35. Small-Signal Step Response, Rising

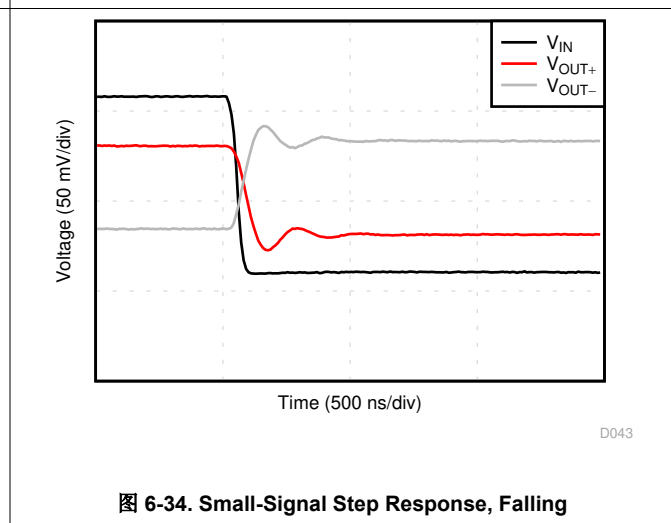

图 6-36. Output Settling Time to $\pm 0.01\%$

6.6 Typical Characteristics (continued)

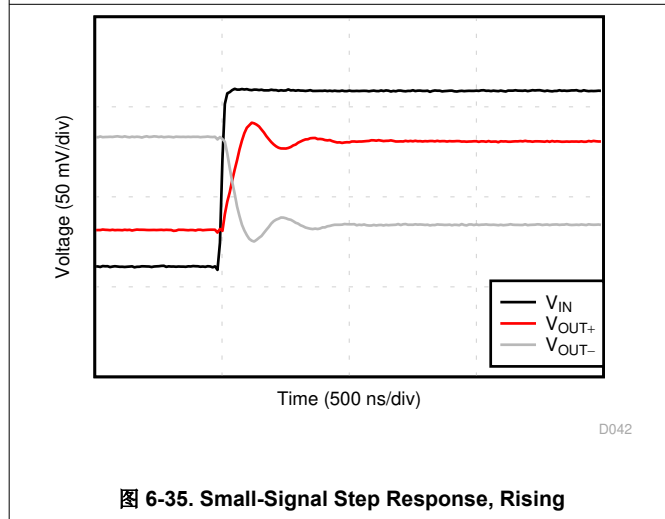
at $V_S = \pm 18\text{ V}$, $T_A = 25^\circ\text{C}$, $V_{VOCM} = V_{VICM} = 0\text{ V}$, $R_F = 2\text{ k}\Omega$, $R_L = 10\text{ k}\Omega$, $V_{OUT} = 2\text{ V}_{PP}$, $G = 1\text{ V/V}$, and $\overline{V_{PD}} = V_{S+}$ (unless otherwise noted)

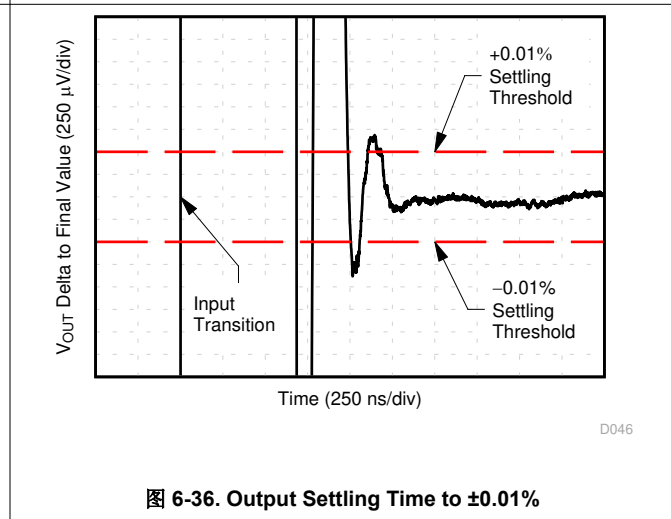

图 6-37. Power-Down Time (PD Low to High)



图 6-38. Power-Down Time (PD High to Low)

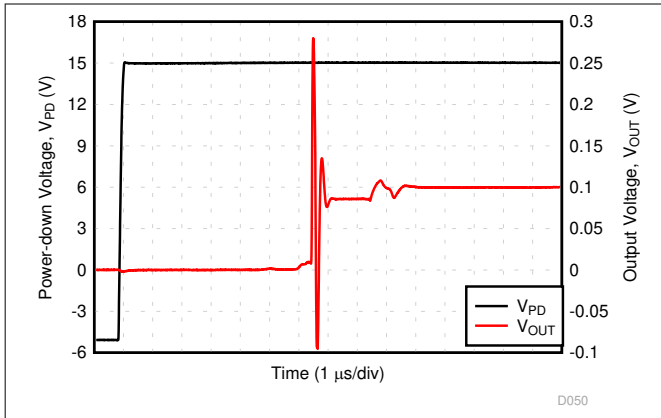

图 6-39. Output Negative Overload Recovery

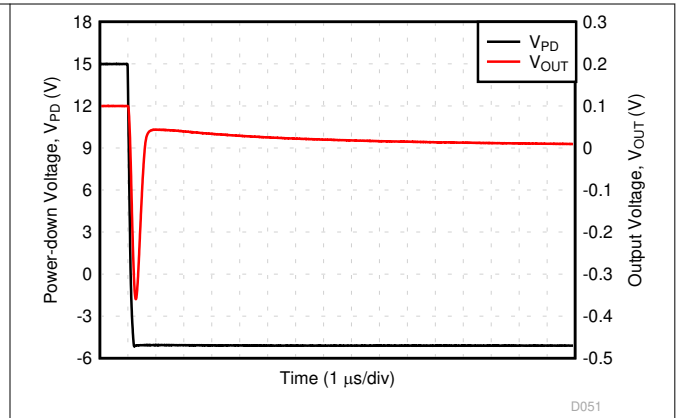

图 6-40. Output Positive Overload Recovery

7 Parameter Measurement Information

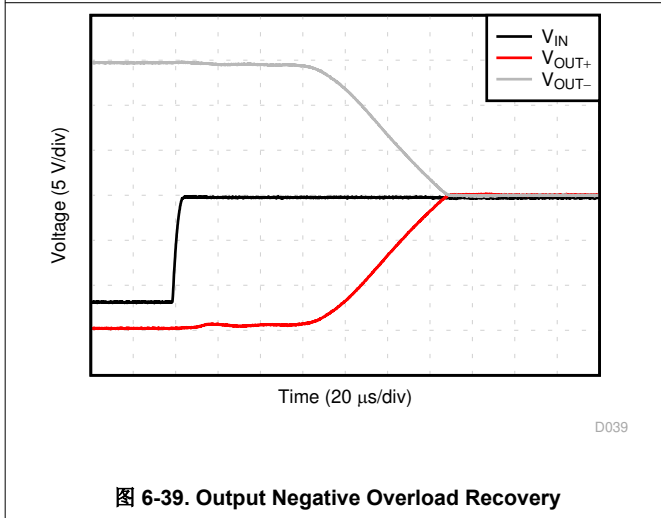
7.1 Characterization Configuration

The OPA1637 provides the advantages of a fully differential amplifier (FDA) configuration that offers very low noise and harmonic distortion in a single, low-power amplifier. The FDA is a flexible device, where the main aim is to provide a purely differential output signal centered on a user-configurable, common-mode voltage that is usually matched to the input common-mode voltage required by an analog-to-digital converter (ADC) or class-D amplifier. The circuit used for characterization of the differential-to-differential performance is seen in [Figure 7-1](#).

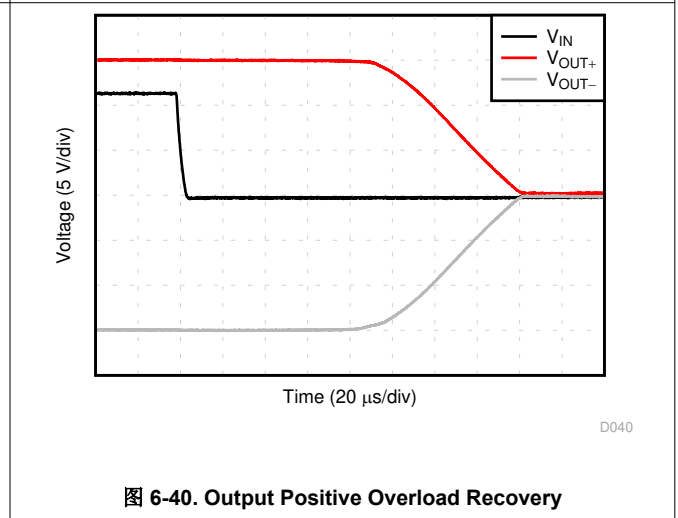
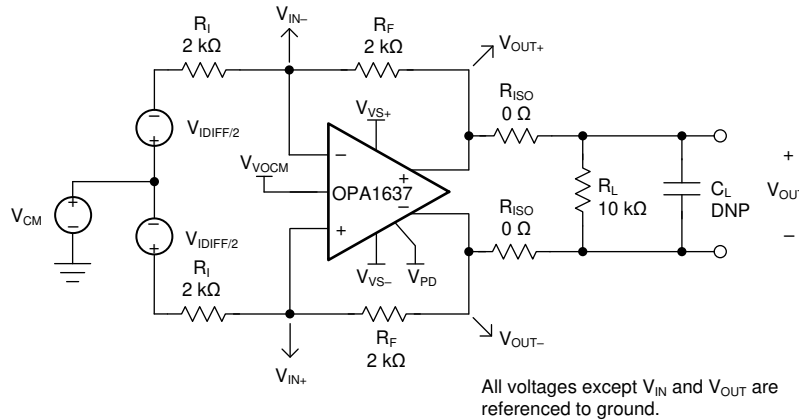

Figure 7-1. Differential Source to a Differential Gain of a 1-V/V Test Circuit

A similar circuit is used for single-ended to differential measurements, as shown in [Figure 7-2](#).

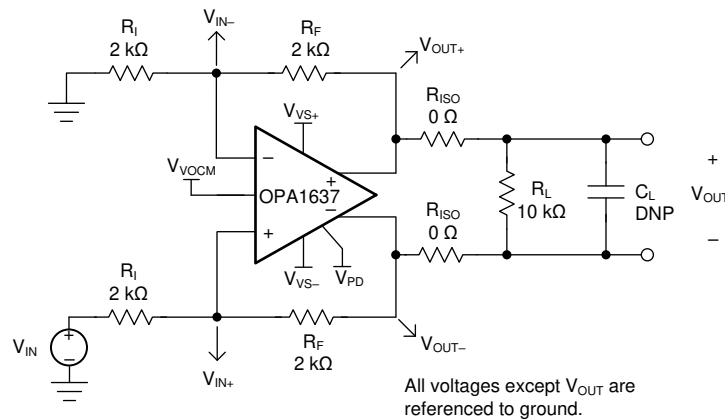

Figure 7-2. Single-Ended to Differential Gain of a 1-V/V Test Circuit

The FDA requires feedback resistor for both output pins to the input pins. These feedback resistors load the output differentially only if the input common-mode voltage is equal to the output common-mode voltage set by VO_{CM}. When VO_{CM} differs from the input common-mode range, the feedback resistors create single-ended loading. The characterization plots fix the R_F (R_{F1} = R_{F2}) value at 2 kΩ, unless otherwise noted. This value can be adjusted to match the system design parameters with the following considerations in mind:

- The current needed to drive R_F from the peak output voltage to the input common-mode voltage adds to the overall output load current. If the total load current (current through R_F + current through R_L) exceeds the current limit conditions, the device enters a current limit state, causing the output voltage to collapse.
- High feedback resistor values (R_F > 100 kΩ) interact with the amplifier input capacitance to create a zero in the feedback network. Compensation must be added to account for this potential source of instability; see the [TI Precision Labs FDA Stability Training](#) for guidance on designing an appropriate compensation network.

8 Detailed Description

8.1 Overview

The OPA1637 is a low-noise, low-distortion fully-differential amplifier (FDA) that features Texas Instrument's super-beta bipolar input devices. Super-beta input devices feature very low input bias current as compared to standard bipolar technology. The low input bias current and current noise makes the OPA1637 an excellent choice for audio applications that require low-noise differential signal processing without significant current consumption. This device is also designed for analog-to-digital audio input circuits that require low noise in a single fully-differential amplifier. This device achieves lower current consumption at lower noise levels than what is achievable with two low-noise amplifiers. The OPA1637 also features high-voltage capability, which allows the device to be used in $\pm 15\text{-V}$ supply circuits without any additional voltage clamping or regulators. This feature enables a direct, single amplifier for a 24-dBm differential output drive (commonly found on mixers and digital audio interfaces) without any additional amplification.

8.2 Functional Block Diagram

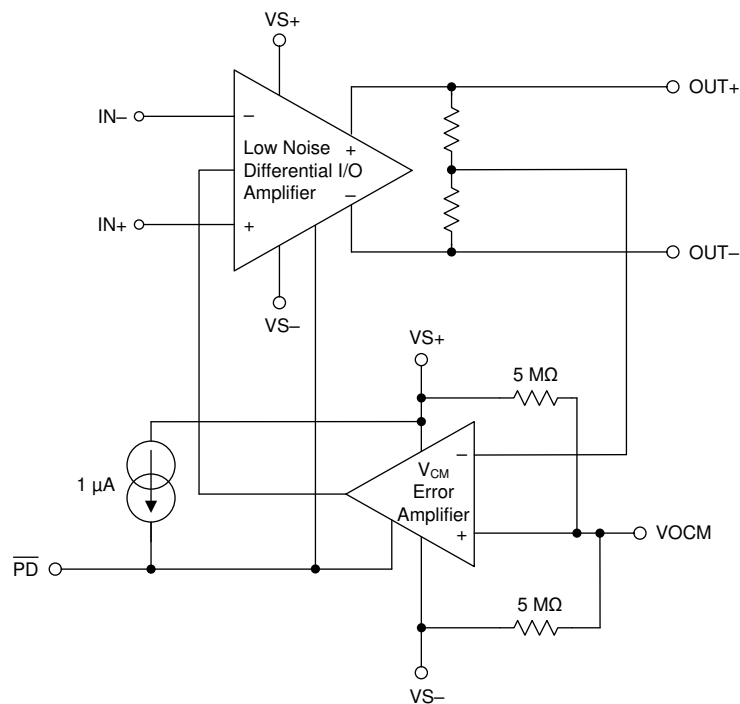

8.3 Feature Description

8.3.1 Super-Beta Input Bipolar Transistors

The OPA1637 is designed on a modern bipolar process that features TI's super-beta input transistors. Traditional bipolar transistors feature excellent voltage noise and offset drift, but suffer a tradeoff in high input bias current (I_B) and high input bias current noise. Super-beta transistors offer the benefits of low voltage noise and low offset drift with an order of magnitude reduction in input bias current and reduction in input bias current noise. For audio circuits, input bias current noise can dominate in circuits where higher resistance input resistors are used. The OPA1637 enables a fully-differential, low-noise amplifier design without restrictions of low input resistance at a power level unmatched by traditional single-ended amplifiers.

8.3.2 Power Down

The OPA1637 features a power-down circuit to disable the amplifier when a low-power mode is required by the system. In the power-down state, the amplifier outputs are in a high-impedance state, and the amplifier total quiescent current is reduced to less than 20 μ A.

8.3.3 Flexible Gain Setting

The OPA1637 offers considerable flexibility in the configuration and selection of resistor values. Low input bias current and bias current noise allows for larger gain resistor values with minimal impact to noise or offset. The design starts with the selection of the feedback resistor value. The 2-k Ω feedback resistor value used for the characterization curves is a good compromise among power, noise, and phase margin considerations. With the feedback resistor values selected (and set equal on each side), the input resistors are set to obtain the desired gain, with the input impedance also set with these input resistors. Differential I/O designs provide an input impedance that is the sum of the two input resistors. Single-ended input to differential output designs present a more complicated input impedance. Most characteristic curves implement the single-ended to differential design as the more challenging requirement over differential-to-differential I/O.

8.3.4 Amplifier Overload Power Limit

In many bipolar-based amplifiers, the output stage of the amplifier can draw significant (several milliamperes) of quiescent current if the output voltage becomes clipped (meaning the output voltage becomes limited by the negative or positive supply voltage). This condition can cause the system to enter a high-power consumption state, and potentially cause oscillations between the power supply and signal chain. The OPA1637 has an advanced output stage design that eliminates this problem. When the output voltage reaches the V_{VS+} or V_{VS-} voltage, there is virtually no additional current consumption from the nominal quiescent current. This feature helps eliminate any potential system problems when the signal chain is disrupted by a large external transient voltage.

8.4 Device Functional Modes

The OPA1637 has two functional modes: normal operation and power-down. The power-down state is enabled when the voltage on the power-down pin is lowered to less than the power-down threshold. In the power-down state, the quiescent current is significantly reduced, and the output voltage is high-impedance. This high impedance can lead to the input voltages (+IN and -IN) separating, and forward-biasing the ESD protection diodes. See [# 9](#) for guidance on power-down operation.

9 Application and Implementation

Note

以下应用部分的信息不属于 TI 组件规范，TI 不担保其准确性和完整性。客户应负责确定 TI 组件是否适用于其应用。客户应验证并测试其设计，以确保系统功能。

9.1 Application Information

Most applications for the OPA1637 strive to deliver the best dynamic range in a design that delivers the desired signal processing along with adequate phase margin for the amplifier. The following sections detail some of the design issues with analysis and guidelines for improved performance.

9.1.1 Driving Capacitive Loads

The capacitive load of an ADC, or some other next-stage device, is commonly required to be driven. Directly connecting a capacitive load to the output pins of a closed-loop amplifier such as the OPA1637 can lead to an unstable response. One typical remedy to this instability is to add two small series resistors (R_{ISO}) at the outputs of the OPA1637 before the capacitive load. Good practice is to leave a place for the R_{ISO} elements in a board layout (a 0- Ω value initially) for later adjustment, in case the response appears unacceptable.

For applications where the OPA1637 is used as an output device to drive an unknown capacitive load, such as a cable, R_{ISO} is required. 图 9-1 shows the required R_{ISO} value for a 40-degree phase-margin response. The peak required R_{ISO} value occurs when C_L is between 500 pF and 1 nF. As C_L increases beyond 1 nF, the bandwidth response of the device reduces, resulting in a slower response but no major degradation in phase margin. For a typical cable type, such as Belden 8451, capacitive loading can vary from 340 pF (10-foot cable) to 1.7 nF (50-foot cable). Selecting R_{ISO} to be 100 Ω provides sufficient phase margin regardless of the cable length. R_{ISO} can also be used within the loop feedback of the amplifier; however, simulation must be used to verify the stability of the system.



图 9-1. Required Isolation Resistance vs Capacitive Load for a 40° Phase Margin

9.1.2 Operating the Power-Down Feature

The power-down feature on the OPA1637 allows the device to be put into a low power-consumption state, in which quiescent current is minimized. To force the device into the low-power state, drive the $\overline{\text{PD}}$ pin lower than the power-down threshold voltage ($V_{\text{VS}+} - 2 \text{ V}$). Driving the PD pin lower than the power-down threshold voltage forces the internal logic to disable both the differential and common-mode amplifiers. The $\overline{\text{PD}}$ pin has an internal pullup current that allows the pin to be used in an open-drain MOSFET configuration without an additional pullup resistor, as seen in [Figure 9-2](#). In this configuration, the logic level can be referenced to the MOSFET, and the voltage at the $\overline{\text{PD}}$ pin is level-shifted to account for use with high supply voltages. Be sure to select an N-type MOSFET with a maximum B_{VDS} greater than the total supply voltage. For applications that do not use the power-down feature, tie the PD pin to the positive supply voltage.

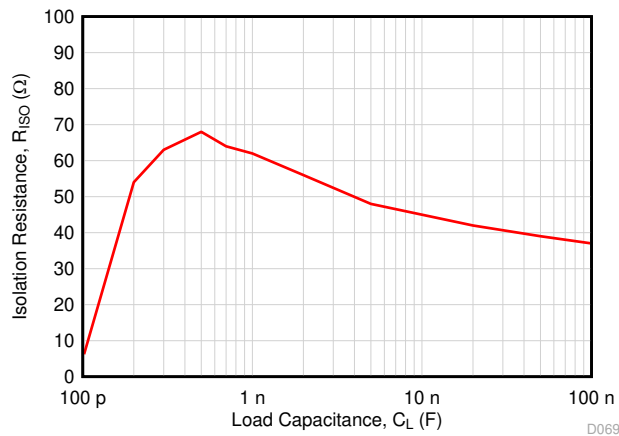

图 9-2. Power-Down ($\overline{\text{PD}}$) Pin Interface With Low-Voltage Logic Level Signals

When \overline{PD} is low (device is in power down) the output pins will be in a high-impedance state. When the device is in the power-down state, the outputs are high impedance, and the output voltage is no longer controlled by the amplifier, but dependant on the input and load configuration. In this case, the input voltage between IN^- and IN^+ can drift to a voltage that may forward-bias the input protection diodes. Take care to avoid high currents flowing through the input diodes by using an input resistor to limit the current to less than 10 mA. In [图 9-3](#), the OPA1637 is configured in a differential gain of 5 with 100- Ω input resistors. When the device enters power down, the voltage between IN^- and IN^+ increases until the internal protection diode is forward-biased. In this case, exceeding a voltage on V_{IN} with $R_{IN} = 0 \Omega$ of 2.5 V (diode forward voltage estimated at 0.5 V) results in a current greater than 10 mA. To avoid this high current, select R_{IN} so that the maximum current flow is less than 10 mA when V_{IN} is at maximum voltage.

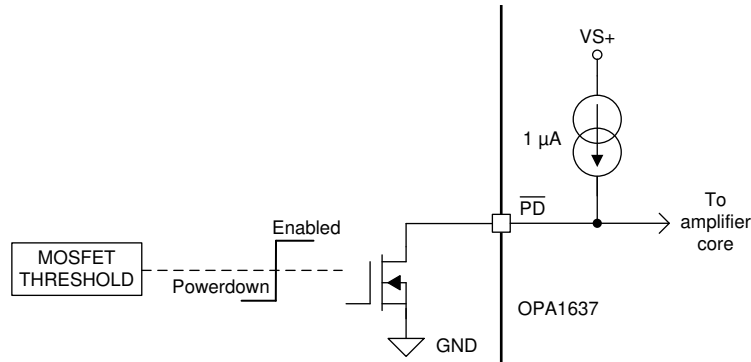

图 9-3. Path of Input Current Flow When $\overline{PD} = \text{Low}$

9.1.3 I/O Headroom Considerations

The starting point for most designs is to assign an output common-mode voltage for the OPA1637. For ac-coupled signal paths, this voltage is often the default midsupply voltage to retain the most available output swing around the voltage centered at the V_{OCM} voltage. For dc-coupled designs, set this voltage with consideration to the required minimum headroom to the supplies, as described in the specifications for the V_{OCM} control. For precision ADC drivers, this V_{OCM} output becomes the V_{CM} input to the ADC. Often, V_{CM} is set to $V_{REF} / 2$ to center the differential input on the available input when precision ADCs are being driven.

From target output V_{OCM} , the next step is to verify that the desired output differential peak-to-peak voltage, V_{OUTPP} , stays within the supplies. For any desired differential V_{OUTPP} , make sure that the absolute maximum voltage at the output pins swings with [方程式 1](#) and [方程式 2](#), and confirm that these expressions are within the supply rails minus the output headroom required for the RRO device.

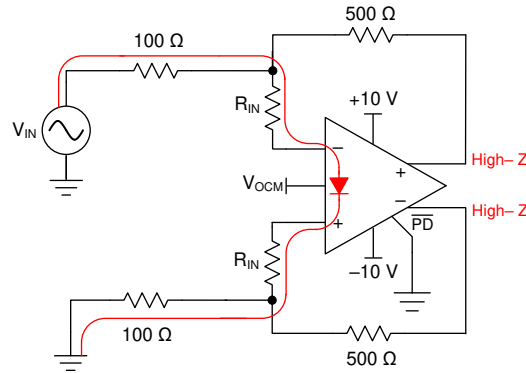
$$V_{OUTMIN} = V_{OCM} - \frac{V_{OUTPP}}{4} \tag{1}$$

$$V_{OUTMAX} = V_{OCM} + \frac{V_{OUTPP}}{4} \tag{2}$$

With the output headroom confirmed, the input junctions must also stay within the operating range. The input range limitations require a maximum 1.0-V headroom from the supply voltages (V_{S+} and V_{S-}) over the full temperature range.

9.1.4 Noise Performance

The first step in the output noise analysis is to reduce the application circuit to the simplest form with equal feedback and gain setting elements to ground. 图 9-4 shows the simplest analysis circuit with the FDA and resistor noise terms to be considered.



图 9-4. FDA Noise Analysis Circuit

The noise powers are shown in 图 9-4 for each term. When the R_F and R_G (or R_I) terms are matched on each side, the total differential output noise is the root sum squared (RSS) of these separate terms. Using $NG \equiv 1 + R_F / R_G$, the total output noise is given by 方程式 3. Each resistor noise term is a $4kT \times R$ power ($4kT = 1.6E-20$ J at 290 K).

$$e_o = \sqrt{(e_{ni}NG)^2 + 2(i_{n+}R_F)^2 + 2(4kTR_FNG)} \tag{3}$$

The first term is simply the differential input spot noise times the noise gain. The second term is the input current noise terms times the feedback resistor (and because there are two uncorrelated current noise terms, the power is two times one of them). The last term is the output noise resulting from both the R_F and R_G resistors, at again, twice the value for the output noise power of each side added together. Running a wide sweep of gains when holding R_F to $2\text{ k}\Omega$ gives the standard values and resulting noise listed in 表 9-1. When the gain increases, the input-referred noise approaches only the gain of the FDA input voltage noise term at $3.7\text{ nV}/\sqrt{\text{Hz}}$.

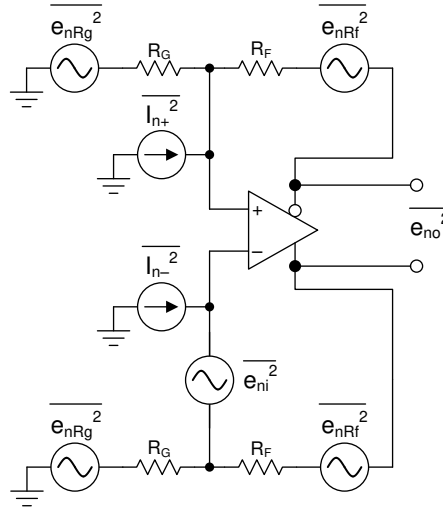
表 9-1. Swept Gain of the Output- and Input-Referred Spot Noise Calculations

GAIN (V/V)	R_F (Ω)	R_{G1} (Ω)	A_V	E_O (nV/ $\sqrt{\text{Hz}}$)	E_I (nV/ $\sqrt{\text{Hz}}$)
0.1	2000	20000	0.1	9.4	93.9
1	2000	2000	1	13.6	13.6
2	2000	1000	2	17.8	8.9
5	2000	402	4.98	29.5	5.9
10	2000	200	10	48.6	4.9

9.2 Typical Applications

9.2.1 Current-Output Audio DAC Buffer to Class-D Amplifier



图 9-5. Differential Current-to-Voltage Converter

9.2.1.1 Design Requirements

The requirements for this application are:

- Differential current-to-voltage conversion and filtering
- 1-kmho transimpedance gain
- 40-kHz Butterworth response filter
- 0-V dc common-mode voltage at DAC output

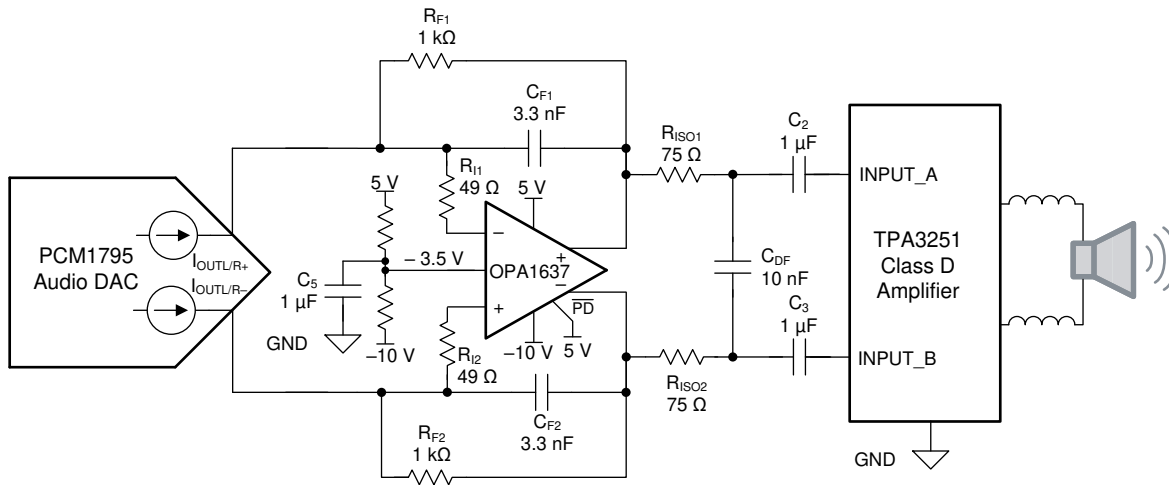
9.2.1.2 Detailed Design Procedure

This design provides current-to-voltage conversion from a current-output audio DAC into a voltage-input, class-D amplifier. The order of design priorities are as follows:

- Select feedback-resistor values based on the gain required from the current-output stage to the voltage-input stage. For this design, the full-scale, peak-to-peak output current of the PCM1795 ($I_{OUTL/R+} - I_{OUTL/R-}$) is ± 4 mA. A gain of 1k gives a wide voltage swing of ± 4 V, allowing for high SNR without exceeding the input voltage limit of the TPA3251.
- After the gain is fixed, select the output common-mode voltage. The output common-mode voltage determines the input common-mode voltage in this configuration. To set the nominal output voltage of the PCM1795 to 0 V (which corresponds to the input common mode voltage of the OPA1637), shift the output negatively from the desired common-mode input voltage by the gain multiplied by the dc center current value of the PCM1795 (3.5 mA). In this case, -3.5 V satisfies the design goal.
- A bypass capacitor from the VOVM pin to ground must be selected to filter noise from the voltage divider. The capacitor selection is determined by balancing the startup time of the system with the output common-mode noise. A higher capacitance gives a lower frequency filter cutoff on the VOVM pin, thus giving lower noise performance, but also slows down the initial startup time of the circuit as a result of the RC delay from the resistor divider in combination with the filter capacitor.
- Select C_F so that the desired bandwidth of the active filter is achieved. The 3-dB frequency is determined by the reciprocal of the product of R_F and C_F .
- Use a passive filter on the output to increase noise filtering beyond the desired bandwidth. The passive filter formed by $R_{D1,2}$ and C_{DF} adds an additional real pole to the filter response. If the pole is designed at the same frequency as the active filter pole, the overall 3-dB frequency shifts to a lower frequency value, and the step response is overdamped. A trade-off must be made to give optimal transient response versus increased filter attenuation at higher frequencies. For this design, the second pole is set to 106 kHz.

9.2.1.3 Application Curves

The simulated response of the current-to-voltage audio DAC buffer can be seen in [图 9-6](#) and [图 9-7](#).

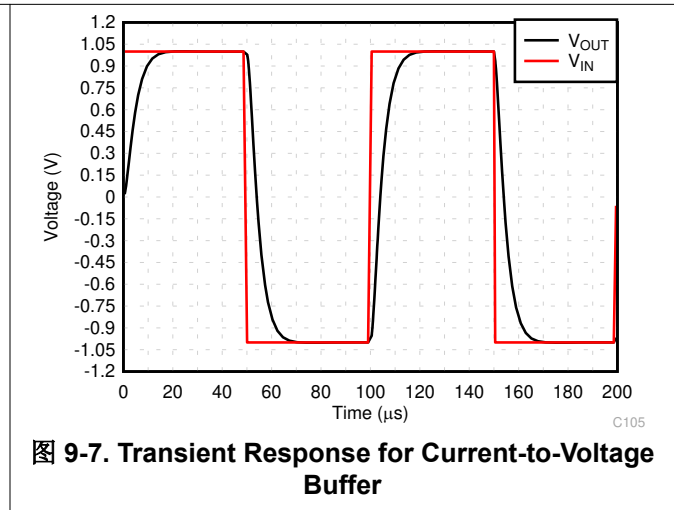
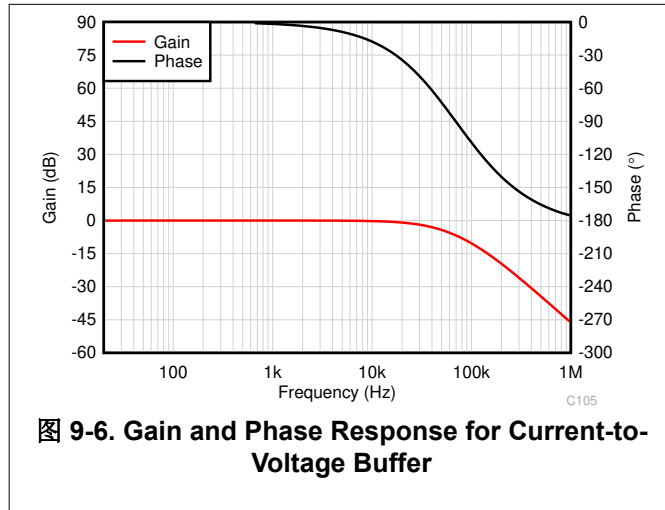

9.2.2 An MFB Filter Driving an ADC Application

A common application use case for fully-differential amplifiers is to easily convert a single-ended signal into a differential signal to drive a differential input source, such as an ADC or class-D amplifier. Figure 9-8 shows an example of the OPA1637 used to convert a single-ended, low-voltage signal audio source, such as a small electret microphone, and deliver a low-noise differential signal that is common-mode shifted to the center of the ADC input range. A multiple-feedback (MFB) configuration is used to provide a Butterworth filter response, giving a 40-dB/decade rolloff with a -3-dB frequency of 30 kHz.



图 9-8. Example 30-kHz Butterworth Filter

9.2.2.1 Design Requirements

The requirements for this application are:

- Single-ended to differential conversion
- 5-V/V gain
- Active filter set to a Butterworth, 30-kHz response shape
- Output RC elements set by SAR input requirements (not part of the filter design)
- Filter element resistors and capacitors are set to limit added noise over the OPA1637 and noise peaking

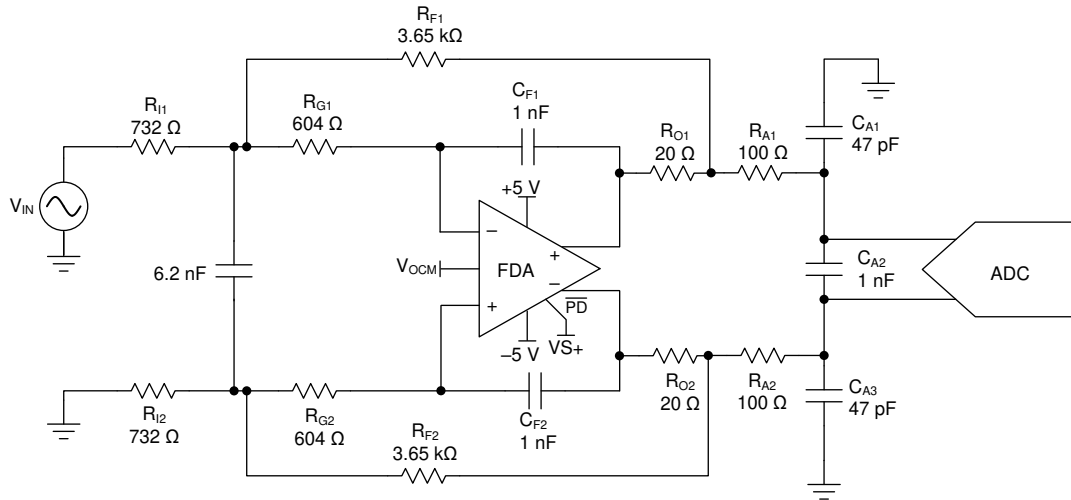
9.2.2.2 Detailed Design Procedure

The design proceeds using the techniques and tools suggested in the [Design Methodology for MFB Filters in ADC Interface Applications application note](#). The process includes:

- Scale the resistor values to not meaningfully contribute to the output noise produced by the OPA1637.
- Select the RC ratios to hit the filter targets when reducing the noise gain peaking within the filter design.
- Set the output resistor to 100 Ω into a 1-nF differential capacitor.
- Add 47-pF common-mode capacitors to the load capacitor to improve common noise filtering.
- Inside the loop, add 20-Ω output resistors after the filter feedback capacitor to increase the isolation to the load capacitor.

9.2.2.3 Application Curves

The gain and phase plots are shown in [Figure 9-9](#). The MFB filter features a Butterworth responses feature very flat passband gain, with a 2-pole roll-off at 30 kHz to eliminate any higher-frequency noise from contaminating the signal chain, and potentially alias back into the audio band.

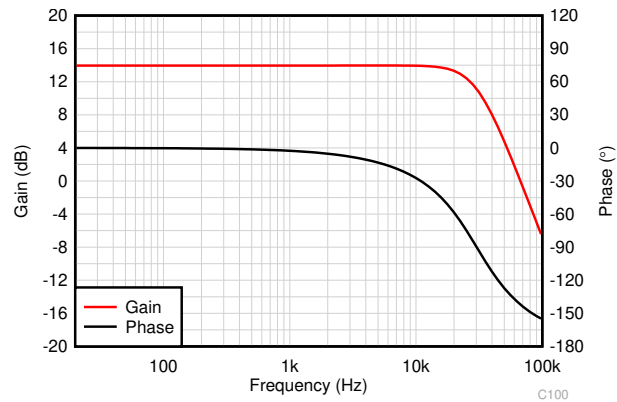

Figure 9-9. Gain and Phase Plot for a 30-kHz Butterworth Filter

9.2.3 Differential Microphone Input to Line Level

Professional dynamic microphones typically feature low output impedance to minimize noise coupling on the microphone cable. Interfacing the microphone with high-impedance circuitry typically requires the use of an impedance conversion stage, often done with a transformer or discrete amplifiers. The flexibility of the OPA1637 allows the device to be configured with a low differential input impedance and 20 dB of gain, simplifying the impedance conversion and gain stage into a single device. 图 9-10 shows an example of a differential, low input impedance, microphone level voltage (10 mV to 100 mV) amplifier to a line-level amplitude signal that also has adjustable dc common-mode shift capability. This design example shows how the OPA1637 makes a great choice for driving an ADC class-D amplifier.



图 9-10. Fully Differential, Low-Noise, 20-dB Microphone Gain Block With DC Shift

9.2.3.1 Application Curves

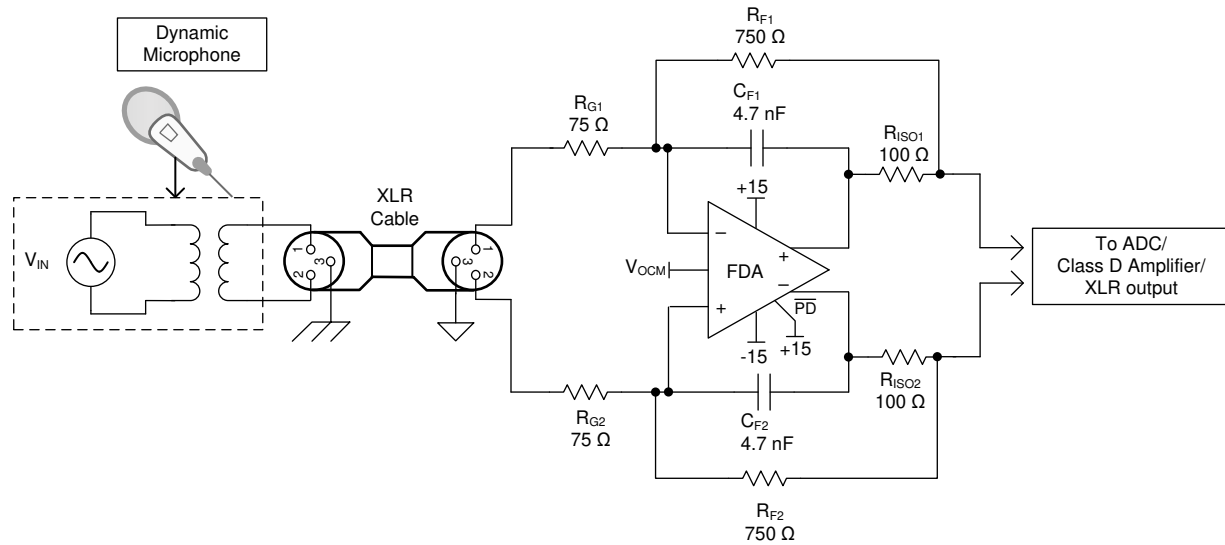

图 9-11. Output Waveform of the Microphone Amplifier

10 Power Supply Recommendations

The OPA1637 operates from supply voltages of 3.0 V to 36 V (± 1.5 V to ± 18 V, dual supply). Connect ceramic bypass capacitors from both VS+ and VS- to GND.

11 Layout

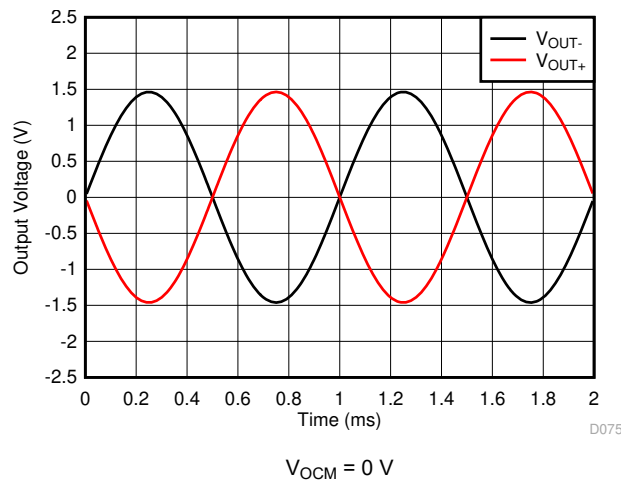
11.1 Layout Guidelines

11.1.1 Board Layout Recommendations

- Keep differential signals routed together to minimize parasitic impedance mismatch.
- Connect a 0.1- μ F capacitor to the supply nodes through a via.
- Connect a 0.1- μ F capacitor to the VO_{CM} pin if no external voltage is used.
- Keep any high-frequency nodes that can couple through parasitic paths away from the VO_{CM} node.
- Clean the PCB board after assembly to minimize any leakage paths from excess flux into the VO_{CM} node.

11.2 Layout Example



图 11-1. Example Layout

12 Device and Documentation Support

12.1 Device Support

12.1.1 Development Support

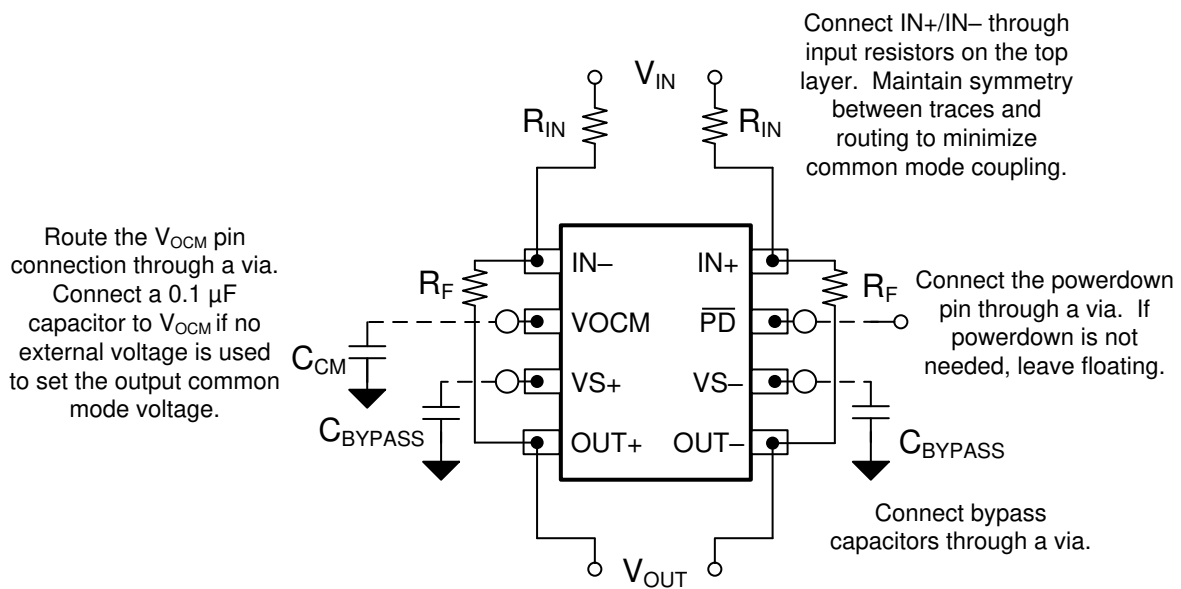
- [OPA1637 TINA-TI™ model](#)
- [TINA-TI Gain of 0.2 100kHz Butterworth MFB Filter](#)
- [TINA-TI 100kHz MFB filter LG test](#)
- [TINA-TI Differential Transimpedance LG Sim](#)

12.2 Documentation Support

12.2.1 Related Documentation

For related documentation see the following:

- Texas Instruments, [OPAx192 36-V, Precision, Rail-to-Rail Input/Output, Low Offset Voltage, Low Input Bias Current Op Amp with e-trim™ data sheet](#)
- Texas Instruments, [OPA161x SoundPlus™ High-Performance, Bipolar-Input Audio Operational Amplifiers data sheet](#)
- Texas Instruments, [Design Methodology for MFB Filters in ADC Interface Applications application report](#)
- Texas Instruments, [Design for Wideband Differential Transimpedance DAC Output application report](#)
- Texas Instruments, [PCM1795 32-Bit, 192-kHz Sampling, Advanced Segment, Stereo Audio Digital-to-Analog Converter data sheet](#)
- Texas Instruments, [TPA3251 175-W Stereo, 350-W Mono PurePath™ Ultra-HD Analog Input Class-D Amplifier data sheet](#)

12.3 接收文档更新通知

要接收文档更新通知，请导航至 ti.com 上的器件产品文件夹。点击 [订阅更新](#) 进行注册，即可每周接收产品信息更改摘要。有关更改的详细信息，请查看任何已修订文档中包含的修订历史记录。

12.4 支持资源

[TI E2E™ 中文支持论坛](#) 是工程师的重要参考资料，可直接从专家处获得快速、经过验证的解答和设计帮助。搜索现有解答或提出自己的问题，获得所需的快速设计帮助。

链接的内容由各个贡献者“按原样”提供。这些内容并不构成 TI 技术规范，并且不一定反映 TI 的观点；请参阅 TI 的 [使用条款](#)。

12.5 Trademarks

Burr-Brown™ and TI E2E™ are trademarks of Texas Instruments.

所有商标均为其各自所有者的财产。

12.6 静电放电警告



静电放电 (ESD) 会损坏这个集成电路。德州仪器 (TI) 建议通过适当的预防措施处理所有集成电路。如果不遵守正确的处理和安装程序，可能会损坏集成电路。

ESD 的损坏小至导致微小的性能降级，大至整个器件故障。精密的集成电路可能更容易受到损坏，这是因为非常细微的参数更改都可能会导致器件与其发布的规格不相符。

12.7 术语表

[TI 术语表](#) 本术语表列出并解释了术语、首字母缩略词和定义。

13 Mechanical, Packaging, and Orderable Information

The following pages include mechanical, packaging, and orderable information. This information is the most current data available for the designated devices. This data is subject to change without notice and revision of this document. For browser-based versions of this data sheet, refer to the left-hand navigation.

PACKAGING INFORMATION

Orderable Device	Status (1)	Package Type	Package Drawing	Pins	Package Qty	Eco Plan (2)	Lead finish/ Ball material (6)	MSL Peak Temp (3)	Op Temp (°C)	Device Marking (4/5)	Samples
OPA1637DGKR	ACTIVE	VSSOP	DGK	8	2500	RoHS & Green	NIPDAU SN NIPDAUAG	Level-2-260C-1 YEAR	-40 to 125	1637	Samples
OPA1637DGKT	ACTIVE	VSSOP	DGK	8	250	RoHS & Green	NIPDAU SN NIPDAUAG	Level-2-260C-1 YEAR	-40 to 125	1637	Samples

(1) The marketing status values are defined as follows:

ACTIVE: Product device recommended for new designs.

LIFEBUY: TI has announced that the device will be discontinued, and a lifetime-buy period is in effect.

NRND: Not recommended for new designs. Device is in production to support existing customers, but TI does not recommend using this part in a new design.

PREVIEW: Device has been announced but is not in production. Samples may or may not be available.

OBsolete: TI has discontinued the production of the device.

(2) **RoHS:** TI defines "RoHS" to mean semiconductor products that are compliant with the current EU RoHS requirements for all 10 RoHS substances, including the requirement that RoHS substance do not exceed 0.1% by weight in homogeneous materials. Where designed to be soldered at high temperatures, "RoHS" products are suitable for use in specified lead-free processes. TI may reference these types of products as "Pb-Free".

RoHS Exempt: TI defines "RoHS Exempt" to mean products that contain lead but are compliant with EU RoHS pursuant to a specific EU RoHS exemption.

Green: TI defines "Green" to mean the content of Chlorine (Cl) and Bromine (Br) based flame retardants meet JS709B low halogen requirements of <=1000ppm threshold. Antimony trioxide based flame retardants must also meet the <=1000ppm threshold requirement.

(3) MSL, Peak Temp. - The Moisture Sensitivity Level rating according to the JEDEC industry standard classifications, and peak solder temperature.

(4) There may be additional marking, which relates to the logo, the lot trace code information, or the environmental category on the device.

(5) Multiple Device Markings will be inside parentheses. Only one Device Marking contained in parentheses and separated by a "~" will appear on a device. If a line is indented then it is a continuation of the previous line and the two combined represent the entire Device Marking for that device.

(6) Lead finish/Ball material - Orderable Devices may have multiple material finish options. Finish options are separated by a vertical ruled line. Lead finish/Ball material values may wrap to two lines if the finish value exceeds the maximum column width.

Important Information and Disclaimer:The information provided on this page represents TI's knowledge and belief as of the date that it is provided. TI bases its knowledge and belief on information provided by third parties, and makes no representation or warranty as to the accuracy of such information. Efforts are underway to better integrate information from third parties. TI has taken and continues to take reasonable steps to provide representative and accurate information but may not have conducted destructive testing or chemical analysis on incoming materials and chemicals. TI and TI suppliers consider certain information to be proprietary, and thus CAS numbers and other limited information may not be available for release.

In no event shall TI's liability arising out of such information exceed the total purchase price of the TI part(s) at issue in this document sold by TI to Customer on an annual basis.

TAPE AND REEL INFORMATION

QUADRANT ASSIGNMENTS FOR PIN 1 ORIENTATION IN TAPE

*All dimensions are nominal

Device	Package Type	Package Drawing	Pins	SPQ	Reel Diameter (mm)	Reel Width W1 (mm)	A0 (mm)	B0 (mm)	K0 (mm)	P1 (mm)	W (mm)	Pin1 Quadrant
OPA1637DGKR	VSSOP	DGK	8	2500	330.0	12.4	5.3	3.4	1.4	8.0	12.0	Q1
OPA1637DGKT	VSSOP	DGK	8	250	330.0	12.4	5.3	3.4	1.4	8.0	12.0	Q1
OPA1637DGKT	VSSOP	DGK	8	250	330.0	12.4	5.3	3.4	1.4	8.0	12.0	Q1
OPA1637DGKT	VSSOP	DGK	8	250	330.0	12.4	5.25	3.35	1.25	8.0	12.0	Q1

TAPE AND REEL BOX DIMENSIONS

*All dimensions are nominal

Device	Package Type	Package Drawing	Pins	SPQ	Length (mm)	Width (mm)	Height (mm)
OPA1637DGKR	VSSOP	DGK	8	2500	356.0	356.0	35.0
OPA1637DGKT	VSSOP	DGK	8	250	356.0	356.0	35.0
OPA1637DGKT	VSSOP	DGK	8	250	366.0	364.0	50.0
OPA1637DGKT	VSSOP	DGK	8	250	366.0	364.0	50.0

DGK0008A



PACKAGE OUTLINE

VSSOP - 1.1 mm max height

SMALL OUTLINE PACKAGE



NOTES:

PowerPAD is a trademark of Texas Instruments.

1. All linear dimensions are in millimeters. Any dimensions in parenthesis are for reference only. Dimensioning and tolerancing per ASME Y14.5M.
2. This drawing is subject to change without notice.
3. This dimension does not include mold flash, protrusions, or gate burrs. Mold flash, protrusions, or gate burrs shall not exceed 0.15 mm per side.
4. This dimension does not include interlead flash. Interlead flash shall not exceed 0.25 mm per side.
5. Reference JEDEC registration MO-187.

EXAMPLE BOARD LAYOUT

DGK0008A

™ VSSOP - 1.1 mm max height

SMALL OUTLINE PACKAGE



LAND PATTERN EXAMPLE
EXPOSED METAL SHOWN
SCALE: 15X



SOLDER MASK DETAILS

4214862/A 04/2023

NOTES: (continued)

6. Publication IPC-7351 may have alternate designs.
7. Solder mask tolerances between and around signal pads can vary based on board fabrication site.
8. Vias are optional depending on application, refer to device data sheet. If any vias are implemented, refer to their locations shown on this view. It is recommended that vias under paste be filled, plugged or tented.
9. Size of metal pad may vary due to creepage requirement.

EXAMPLE STENCIL DESIGN

DGK0008A

™ VSSOP - 1.1 mm max height

SMALL OUTLINE PACKAGE



SOLDER PASTE EXAMPLE
SCALE: 15X

4214862/A 04/2023

NOTES: (continued)

11. Laser cutting apertures with trapezoidal walls and rounded corners may offer better paste release. IPC-7525 may have alternate design recommendations.
12. Board assembly site may have different recommendations for stencil design.

重要声明和免责声明

TI“按原样”提供技术和可靠性数据（包括数据表）、设计资源（包括参考设计）、应用或其他设计建议、网络工具、安全信息和其他资源，不保证没有瑕疵且不做任何明示或暗示的担保，包括但不限于对适销性、某特定用途方面的适用性或不侵犯任何第三方知识产权的暗示担保。

这些资源可供使用 TI 产品进行设计的熟练开发人员使用。您将自行承担以下全部责任：(1) 针对您的应用选择合适的 TI 产品，(2) 设计、验证并测试您的应用，(3) 确保您的应用满足相应标准以及任何其他功能安全、信息安全、监管或其他要求。

这些资源如有变更，恕不另行通知。TI 授权您仅可将这些资源用于研发本资源所述的 TI 产品的应用。严禁对这些资源进行其他复制或展示。您无权使用任何其他 TI 知识产权或任何第三方知识产权。您应全额赔偿因在这些资源的使用中对 TI 及其代表造成的任何索赔、损害、成本、损失和债务，TI 对此概不负责。

TI 提供的产品受 [TI 的销售条款](#) 或 [ti.com](#) 上其他适用条款/TI 产品随附的其他适用条款的约束。TI 提供这些资源并不会扩展或以其他方式更改 TI 针对 TI 产品发布的适用的担保或担保免责声明。

TI 反对并拒绝您可能提出的任何其他或不同的条款。

邮寄地址：Texas Instruments, Post Office Box 655303, Dallas, Texas 75265

Copyright © 2024，德州仪器 (TI) 公司