

SNx4ACT00 四路双输入正与非门

1 特性

- 4.5V 至 5.5V V_{CC} 运行
- 输入电压高达 5.5V
- t_{pd} 最大值为 8ns (5V 时)
- 输入兼容 TTL 电压

2 说明

‘ACT00 器件包含四个独立双输入与非门。每个逻辑门以正逻辑执行布尔函数 $Y = \overline{A \cdot B}$ 或 $Y = \overline{A + B}$ 。

器件信息

器件型号	封装 ⁽¹⁾	封装尺寸 ⁽²⁾	本体尺寸 ⁽³⁾
SNx4ACT00	D (SOIC , 14)	8.65mm × 6mm	8.65mm × 3.9mm
	DB (SSOP , 14)	6.20mm × 7.8mm	6.20mm × 5.30mm
	N (PDIP , 14)	19.30mm × 9.4mm	19.30mm × 6.35mm
	NS (SOP , 14)	10.2mm × 7.8mm	10.30mm × 5.30mm
	PW (TSSOP , 14)	5mm × 6.4mm	mm × 4.4mm

- (1) 如需了解更多信息，请参阅[机械、封装和可订购信息](#)。
- (2) 封装尺寸 (长 × 宽) 为标称值，并包括引脚 (如适用)。
- (3) 本体尺寸 (长 × 宽) 为标称值，不包括引脚。



逻辑图，每个逻辑门 (正逻辑)



Table of Contents

1 特性	1	7 Application and Implementation	7
2 说明	1	7.1 Power Supply Recommendations.....	7
3 Pin Configuration and Functions	3	7.2 Layout.....	7
4 Specifications	4	8 Device and Documentation Support	8
4.1 Absolute Maximum Ratings.....	4	8.1 Documentation Support (Analog).....	8
4.2 Recommended Operating Conditions.....	4	8.2 接收文档更新通知.....	8
4.3 Thermal Information.....	4	8.3 支持资源.....	8
4.4 Electrical Characteristics.....	5	8.4 Trademarks.....	8
4.5 Switching Characteristics.....	5	8.5 静电放电警告.....	8
4.6 Operating Characteristics.....	5	8.6 术语表.....	8
5 Parameter Measurement Information	6	9 Revision History	8
6 Detailed Description	6	10 Mechanical, Packaging, and Orderable Information	9
6.1 Functional Block Diagram.....	6		
6.2 Device Functional Modes.....	6		

3 Pin Configuration and Functions



图 3-1. SN54ACT00 J or W Package; SN74ACT00 D, DB, N, NS, or PW Package (Top View)



NC - No internal connection

图 3-2. SN54ACT00 FK Package (Top View)

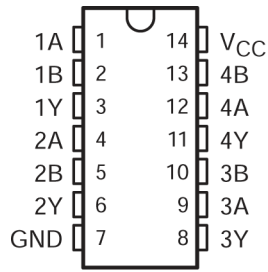
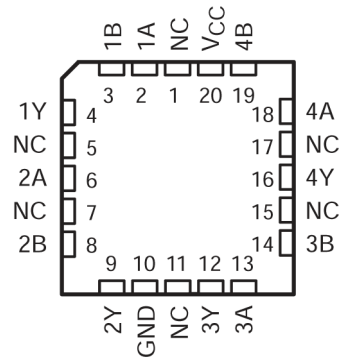
表 3-1. Pin Functions

PIN		TYPE ⁽¹⁾	DESCRIPTION
NAME	NO.		
1A	1	I	Channel 1, Input A
1B	2	I	Channel 1, Input B
1Y	3	O	Channel 1, Output Y
2A	4	I	Channel 2, Input A
2B	5	I	Channel 2, Input B
2Y	6	O	Channel 2, Output Y
3A	9	O	Channel 3, Output Y
3B	10	I	Channel 3, Input A
3Y	8	I	Channel 3, Input B
4A	12	O	Channel 4, Output Y
4B	13	I	Channel 4, Input A
4Y	11	I	Channel 4, Input B
GND	7	G	Ground
V _{CC}	14	P	Positive Supply

(1) Signal Types: I = Input, O = Output, I/O = Input or Output, P = Power Supply, G = Ground.

4 Specifications

4.1 Absolute Maximum Ratings

over operating free-air temperature range (unless otherwise noted)⁽¹⁾

		MIN	MAX	UNIT
V _{CC}	Supply voltage range	- 0.5	7	V
V _I ⁽²⁾	Input voltage range	- 0.5	V _{CC} + 0.5	V
V _O ⁽²⁾	Output voltage range	- 0.5	V _{CC} + 0.5	V
I _{IK}	Input clamp current	(V _I < 0 or V _I > V _{CC})		±20 mA
I _{OK}	Output clamp current	(V _O < 0 or V _O > V _{CC})		±20 mA
I _O	Continuous output current	(V _O = 0 to V _{CC})		±50 mA
Continuous current through V _{CC} or GND				±200 mA
T _{stg}	Storage temperature range	- 65	150	°C

- (1) Stresses beyond those listed under “absolute maximum ratings” may cause permanent damage to the device. These are stress ratings only, and functional operation of the device at these or any other conditions beyond those indicated under “recommended operating conditions” is not implied. Exposure to absolute-maximum-rated conditions for extended periods may affect device reliability.
- (2) The input and output voltage ratings may be exceeded if the input and output current ratings are observed.

4.2 Recommended Operating Conditions

over operating free-air temperature range (unless otherwise noted)⁽¹⁾

		SN54ACT00		SN74ACT00		UNIT
		MIN	MAX	MIN	MAX	
V _{CC}	Supply voltage	4.5	5.5	4.5	5.5	V
V _{IH}	High-level input voltage	2		2		V
V _{IL}	Low-level input voltage		0.8		0.8	V
V _I	Input voltage	0	V _{CC}	0	V _{CC}	V
V _O	Output voltage	0	V _{CC}	0	V _{CC}	V
I _{OH}	High-level output current		- 24		- 24	mA
I _{OL}	Low-level output current		24		24	mA
Δt/Δv	Input transition rise or fall rate		8		8	ns/V
T _A	Operating free-air temperature	- 55	125	- 40	85	°C

- (1) All unused inputs of the device must be held at V_{CC} or GND to ensure proper device operation. Refer to the TI application report, *Implications of Slow or Floating CMOS Inputs*, literature number SCBA004.

4.3 Thermal Information

THERMAL METRIC ⁽¹⁾		SNx4ACT00					UNIT
		D (SOIC)	DB (SSOP)	N (PDIP)	NS (SOP)	PW (TSSOP)	
		14 PINS	14 PINS	14 PINS	14 PINS	14 PINS	
R _{θJA}	Junction-to-ambient thermal resistance	119.9	96	80	76	145.7	°C/W

- (1) For more information about traditional and new thermal metrics, see the [Semiconductor and IC package thermal metrics](#) application report.

4.4 Electrical Characteristics

over recommended operating free-air temperature range (unless otherwise noted)

PARAMETER	TEST CONDITIONS	V _{CC}	T _A = 25°C			SN54ACT00		SN74ACT00		UNIT
			MIN	TYP	MAX	MIN	MAX	MIN	MAX	
V _{OH}	I _{OH} = - 50 μA	4.5 V	4.4	4.49		4.4		4.4	V	
		5.5 V	5.4	5.49		5.4		5.4		
	I _{OH} = - 24 mA	4.5 V	3.86			3.7		3.76		
		5.5 V	4.86			4.7		4.76		
	I _{OH} = - 50 mA ⁽¹⁾	5.5 V				3.85				
I _{OH} = - 75 mA ⁽¹⁾	5.5 V						3.85			
V _{OL}	I _{OL} = 50 μA	4.5 V	0.001	0.1		0.1		0.1	V	
		5.5 V	0.001	0.1		0.1		0.1		
	I _{OH} = 24 mA	4.5 V				0.36		0.44		
		5.5 V				0.36		0.44		
	I _{OH} = 50 mA ⁽¹⁾	5.5 V					1.65			
I _{OH} = 75 mA ⁽¹⁾	5.5 V						1.65			
I _I	V _I = V _{CC} or GND	5.5 V				±0.1		±1	μA	
I _{CC}	V _I = V _{CC} or GND I _O = 0	5.5 V				2		40	20	μA
Δ I _{CC} ⁽²⁾	One input at 3.4 V, Other inputs at GND or V _{CC}	5.5 V				0.6		1.6	1.5	mA
C _i	V _I = V _{CC} or GND	5 V				2.6				pF

(1) Not more than one output should be tested at a time, and the duration of the test should not exceed 2 ms.

(2) This is the increase in supply current for each input that is at one of the specified TTL voltage levels, rather than 0 V or V_{CC}.

4.5 Switching Characteristics

over recommended operating free-air temperature range, V_{CC} = 5 V ± 0.5 V (unless otherwise noted) (see [Load Circuit and Voltage Waveforms](#))

PARAMETER	FROM (INPUT)	TO (OUTPUT)	T _A = 25°C			SNx4ACT00		SNx4ACT00		UNIT
			MIN	TYP	MAX	MIN	MAX	MIN	MAX	
t _{PLH}	A or B	Y	1.5	5.5	9	1	9.5	1	9.5	ns
t _{PHL}			1.5	4	7	1	7	1	8	

4.6 Operating Characteristics

V_{CC} = 5 V, T_A = 25°C

PARAMETER	TEST CONDITIONS	TYP	UNIT
C _{pd} Power dissipation capacitance	C _L = 50 pF f = 1 MHz	40	pF

5 Parameter Measurement Information

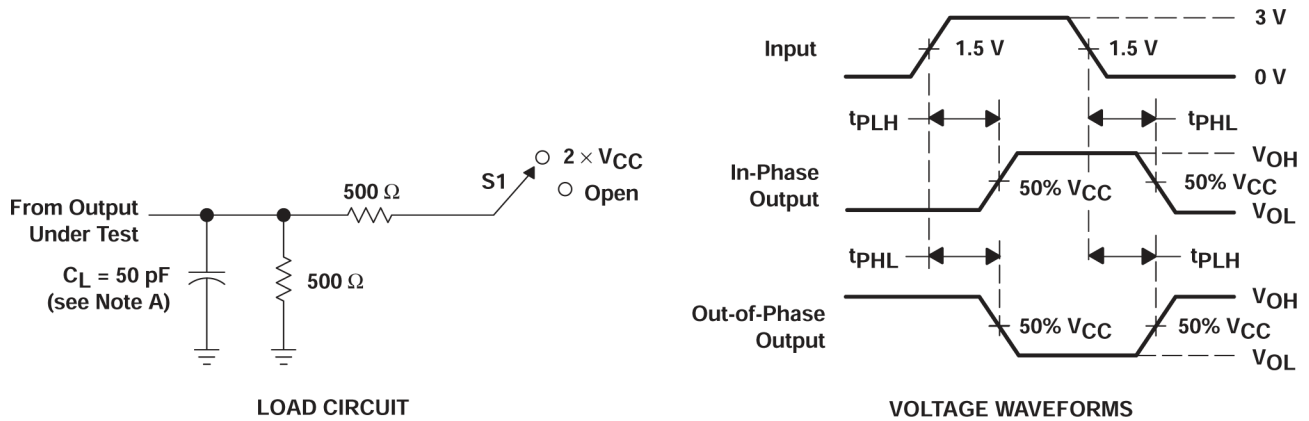

- A. C_L includes probe and jig capacitance.
- B. All input pulses are supplied by generators having the following characteristics: PRR ≤ 1 MHz, Z_O = 50 Ω, t_r ≤ 2.5 ns, t_f ≤ 2.5 ns.
- C. The outputs are measured one at a time with one input transition per measurement.

图 5-1. Load Circuit and Voltage Waveforms

TEST	S1
t _{PLH} /t _{PHL}	Open

6 Detailed Description

6.1 Functional Block Diagram



图 6-1. Logic Diagram, Each Gate (Positive Logic)

6.2 Device Functional Modes

表 6-1. Function Table (Each Gate)

INPUTS		OUTPUT
A	B	Y
H	H	L
L	X	H
X	L	H

7 Application and Implementation

备注

以下应用部分中的信息不属于 TI 器件规格的范围，TI 不担保其准确性和完整性。TI 的客户应负责确定器件是否适用于其应用。客户应验证并测试其设计，以确保系统功能。

7.1 Power Supply Recommendations

The power supply can be any voltage between the minimum and maximum supply voltage rating located in the *Recommended Operating Conditions*. Each V_{CC} terminal should have a good bypass capacitor to prevent power disturbance. A 0.1- μ F capacitor is recommended for this device. It is acceptable to parallel multiple bypass capacitors to reject different frequencies of noise. The 0.1- μ F and 1- μ F capacitors are commonly used in parallel. The bypass capacitor should be installed as close to the power terminal as possible for best results, as shown in the following layout example.

7.2 Layout

7.2.1 Layout Guidelines

When using multiple-input and multiple-channel logic devices inputs must never be left floating. In many cases, functions or parts of functions of digital logic devices are unused; for example, when only two inputs of a triple-input AND gate are used or only 3 of the 4 buffer gates are used. Such unused input pins must not be left unconnected because the undefined voltages at the outside connections result in undefined operational states. All unused inputs of digital logic devices must be connected to a logic high or logic low voltage, as defined by the input voltage specifications, to prevent them from floating. The logic level that must be applied to any particular unused input depends on the function of the device. Generally, the inputs are tied to GND or V_{CC} , whichever makes more sense for the logic function or is more convenient.

7.2.2 Layout Example



图 7-1. Example Layout for the SNx4ACT00

8 Device and Documentation Support

TI offers an extensive line of development tools. Tools and software to evaluate the performance of the device, generate code, and develop solutions are listed below.

8.1 Documentation Support (Analog)

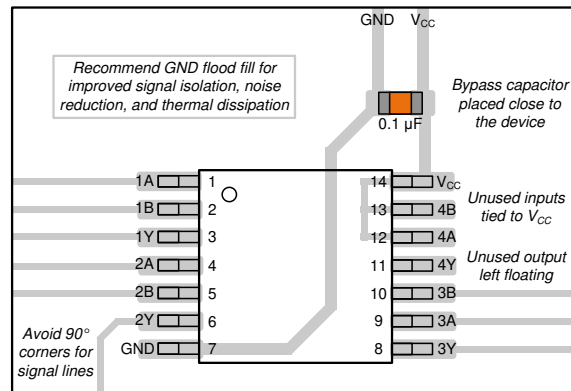
8.1.1 Related Documentation

The table below lists quick access links. Categories include technical documents, support and community resources, tools and software, and quick access to sample or buy.

表 8-1. Related Links

PARTS	PRODUCT FOLDER	SAMPLE & BUY	TECHNICAL DOCUMENTS	TOOLS & SOFTWARE	SUPPORT & COMMUNITY
SN54ACT00	Click here	Click here	Click here	Click here	Click here
SN74ACT00	Click here	Click here	Click here	Click here	Click here

8.2 接收文档更新通知

要接收文档更新通知，请导航至 ti.com 上的器件产品文件夹。点击 [通知](#) 进行注册，即可每周接收产品信息更改摘要。有关更改的详细信息，请查看任何已修订文档中包含的修订历史记录。

8.3 支持资源

[TI E2E™ 中文支持论坛](#) 是工程师的重要参考资料，可直接从专家处获得快速、经过验证的解答和设计帮助。搜索现有解答或提出自己的问题，获得所需的快速设计帮助。

链接的内容由各个贡献者“按原样”提供。这些内容并不构成 TI 技术规范，并且不一定反映 TI 的观点；请参阅 TI 的 [使用条款](#)。

8.4 Trademarks

TI E2E™ is a trademark of Texas Instruments.

所有商标均为其各自所有者的财产。

8.5 静电放电警告



静电放电 (ESD) 会损坏这个集成电路。德州仪器 (TI) 建议通过适当的预防措施处理所有集成电路。如果不遵守正确的处理和安装程序，可能会损坏集成电路。

ESD 的损坏小至导致微小的性能降级，大至整个器件故障。精密的集成电路可能更容易受到损坏，这是因为非常细微的参数更改都可能会导致器件与其发布的规格不相符。

8.6 术语表

[TI 术语表](#) 本术语表列出并解释了术语、首字母缩略词和定义。

9 Revision History

注：以前版本的页码可能与当前版本的页码不同

Changes from Revision D (October 2003) to Revision E (July 2024)	Page
• 添加了应用部分、器件信息表、引脚功能表、ESD 等级表、热性能信息表、器件功能模式、应用和实施部分、器件和文档支持部分以及机械、封装和可订购信息部分.....	1
• Updated R ^θ JA values: D = 86 to 119.9, PW = 113 to 145.7, all values in °C/W.....	4

10 Mechanical, Packaging, and Orderable Information

The following pages include mechanical, packaging, and orderable information. This information is the most current data available for the designated devices. This data is subject to change without notice and revision of this document. For browser-based versions of this data sheet, refer to the left-hand navigation.

PACKAGING INFORMATION

Orderable Device	Status (1)	Package Type	Package Drawing	Pins	Package Qty	Eco Plan (2)	Lead finish/ Ball material (6)	MSL Peak Temp (3)	Op Temp (°C)	Device Marking (4/5)	Samples
5962-8769901M2A	ACTIVE	LCCC	FK	20	55	Non-RoHS & Green	SNPB	N / A for Pkg Type	-55 to 125	5962-8769901M2A SNJ54 ACT00FK	Samples
5962-8769901MCA	ACTIVE	CDIP	J	14	25	Non-RoHS & Green	SNPB	N / A for Pkg Type	-55 to 125	5962-8769901MC A SNJ54ACT00J	Samples
5962-8769901MDA	ACTIVE	CFP	W	14	25	Non-RoHS & Green	SNPB	N / A for Pkg Type	-55 to 125	5962-8769901MD A SNJ54ACT00W	Samples
SN74ACT00D	OBSOLETE	SOIC	D	14		TBD	Call TI	Call TI	-40 to 85	ACT00	
SN74ACT00DBR	ACTIVE	SSOP	DB	14	2000	RoHS & Green	NIPDAU	Level-1-260C-UNLIM	-40 to 85	AD00	Samples
SN74ACT00DR	ACTIVE	SOIC	D	14	2500	RoHS & Green	NIPDAU	Level-1-260C-UNLIM	-40 to 85	ACT00	Samples
SN74ACT00N	ACTIVE	PDIP	N	14	25	RoHS & Green	NIPDAU	N / A for Pkg Type	-40 to 85	SN74ACT00N	Samples
SN74ACT00NE4	ACTIVE	PDIP	N	14	25	RoHS & Green	NIPDAU	N / A for Pkg Type	-40 to 85	SN74ACT00N	Samples
SN74ACT00NSR	ACTIVE	SO	NS	14	2000	RoHS & Green	NIPDAU	Level-1-260C-UNLIM	-40 to 85	ACT00	Samples
SN74ACT00PW	OBSOLETE	TSSOP	PW	14		TBD	Call TI	Call TI	-40 to 85	AD00	
SN74ACT00PWR	ACTIVE	TSSOP	PW	14	2000	RoHS & Green	NIPDAU	Level-1-260C-UNLIM	-40 to 85	AD00	Samples
SNJ54ACT00FK	ACTIVE	LCCC	FK	20	55	Non-RoHS & Green	SNPB	N / A for Pkg Type	-55 to 125	5962-8769901M2A SNJ54 ACT00FK	Samples
SNJ54ACT00J	ACTIVE	CDIP	J	14	25	Non-RoHS & Green	SNPB	N / A for Pkg Type	-55 to 125	5962-8769901MC A SNJ54ACT00J	Samples
SNJ54ACT00W	ACTIVE	CFP	W	14	25	Non-RoHS & Green	SNPB	N / A for Pkg Type	-55 to 125	5962-8769901MD A SNJ54ACT00W	Samples

(1) The marketing status values are defined as follows:
ACTIVE: Product device recommended for new designs.

LIFEBUY: TI has announced that the device will be discontinued, and a lifetime-buy period is in effect.

NRND: Not recommended for new designs. Device is in production to support existing customers, but TI does not recommend using this part in a new design.

PREVIEW: Device has been announced but is not in production. Samples may or may not be available.

OBSOLETE: TI has discontinued the production of the device.

⁽²⁾ **RoHS:** TI defines "RoHS" to mean semiconductor products that are compliant with the current EU RoHS requirements for all 10 RoHS substances, including the requirement that RoHS substance do not exceed 0.1% by weight in homogeneous materials. Where designed to be soldered at high temperatures, "RoHS" products are suitable for use in specified lead-free processes. TI may reference these types of products as "Pb-Free".

RoHS Exempt: TI defines "RoHS Exempt" to mean products that contain lead but are compliant with EU RoHS pursuant to a specific EU RoHS exemption.

Green: TI defines "Green" to mean the content of Chlorine (Cl) and Bromine (Br) based flame retardants meet JS709B low halogen requirements of <=1000ppm threshold. Antimony trioxide based flame retardants must also meet the <=1000ppm threshold requirement.

⁽³⁾ MSL, Peak Temp. - The Moisture Sensitivity Level rating according to the JEDEC industry standard classifications, and peak solder temperature.

⁽⁴⁾ There may be additional marking, which relates to the logo, the lot trace code information, or the environmental category on the device.

⁽⁵⁾ Multiple Device Markings will be inside parentheses. Only one Device Marking contained in parentheses and separated by a "~" will appear on a device. If a line is indented then it is a continuation of the previous line and the two combined represent the entire Device Marking for that device.

⁽⁶⁾ Lead finish/Ball material - Orderable Devices may have multiple material finish options. Finish options are separated by a vertical ruled line. Lead finish/Ball material values may wrap to two lines if the finish value exceeds the maximum column width.

Important Information and Disclaimer:The information provided on this page represents TI's knowledge and belief as of the date that it is provided. TI bases its knowledge and belief on information provided by third parties, and makes no representation or warranty as to the accuracy of such information. Efforts are underway to better integrate information from third parties. TI has taken and continues to take reasonable steps to provide representative and accurate information but may not have conducted destructive testing or chemical analysis on incoming materials and chemicals. TI and TI suppliers consider certain information to be proprietary, and thus CAS numbers and other limited information may not be available for release.

In no event shall TI's liability arising out of such information exceed the total purchase price of the TI part(s) at issue in this document sold by TI to Customer on an annual basis.

OTHER QUALIFIED VERSIONS OF SN54ACT00, SN74ACT00 :

● Catalog : [SN74ACT00](#)

● Automotive : [SN74ACT00-Q1](#), [SN74ACT00-Q1](#)

● Military : [SN54ACT00](#)

NOTE: Qualified Version Definitions:

- Catalog - TI's standard catalog product
- Automotive - Q100 devices qualified for high-reliability automotive applications targeting zero defects
- Military - QML certified for Military and Defense Applications

重要声明和免责声明

TI“按原样”提供技术和可靠性数据（包括数据表）、设计资源（包括参考设计）、应用或其他设计建议、网络工具、安全信息和其他资源，不保证没有瑕疵且不做任何明示或暗示的担保，包括但不限于对适销性、某特定用途方面的适用性或不侵犯任何第三方知识产权的暗示担保。

这些资源可供使用 TI 产品进行设计的熟练开发人员使用。您将自行承担以下全部责任：(1) 针对您的应用选择合适的 TI 产品，(2) 设计、验证并测试您的应用，(3) 确保您的应用满足相应标准以及任何其他功能安全、信息安全、监管或其他要求。

这些资源如有变更，恕不另行通知。TI 授权您仅可将这些资源用于研发本资源所述的 TI 产品的应用。严禁对这些资源进行其他复制或展示。您无权使用任何其他 TI 知识产权或任何第三方知识产权。您应全额赔偿因在这些资源的使用中对 TI 及其代表造成的任何索赔、损害、成本、损失和债务，TI 对此概不负责。

TI 提供的产品受 [TI 的销售条款](#) 或 [ti.com](#) 上其他适用条款/TI 产品随附的其他适用条款的约束。TI 提供这些资源并不会扩展或以其他方式更改 TI 针对 TI 产品发布的适用的担保或担保免责声明。

TI 反对并拒绝您可能提出的任何其他或不同的条款。

邮寄地址：Texas Instruments, Post Office Box 655303, Dallas, Texas 75265

Copyright © 2024，德州仪器 (TI) 公司