

SN74LVC125A 具有三态输出的四路总线缓冲门

1 特性

- 三态输出
- 为所有 4 个缓冲器提供单独的 \overline{OE}
- 工作电压范围为 1.65V 至 3.6V
- 额定工作温度范围为 -40°C 至 85°C 以及 -40°C 至 125°C
- 输入电压高达 5.5V
- 电压为 3.3V 时, t_{pd} 最大值为 4.8ns
- V_{OLP} (输出接地反弹)
典型值小于 0.8V ($V_{CC} = 3.3\text{V}$ 、 $T_A = 25^{\circ}\text{C}$)
- V_{OHV} (输出 V_{OH} 下冲) 典型值
大于 2V ($V_{CC} = 3.3\text{V}$ 、 $T_A = 25^{\circ}\text{C}$ 时)
- 闩锁性能超过 250mA, 符合
JESD 17 规范

2 应用

- 线缆调制解调器终端系统
- IP 电话: 有线和无线
- 光学模块
- 光纤网络:
 - EPON 或光纤视频
- 点对点微波回程
- 电源: 直流/直流通信电源模块:
 - 模拟或数字
- 专用分支交换机 (PBX)
- TETRA 基站
- 电信基带单元
- 电信方舱:
 - 滤波器单元
 - 配电单元 (PDU)
 - 电源监控单元 (PMU)
 - 无线电池监控
 - 远程电动倾斜单元 (RET)
 - 远程射频单元 (RRU)
 - 塔顶放大器 (TMA)
- 矢量信号分析仪和发生器
- 视频会议: 基于 IP 的高清视频
- WiMAX 和无线基础设施设备
- 无线通信测试仪
- xDSL 调制解调器和 DSLAM

3 说明

这款四路总线缓冲门可在 1.65V 至 3.6V V_{CC} 下运行。

SN74LVC125A 器件具有提供三态输出的独立线路驱动器。当每个输出的相关输出使能 (\overline{OE}) 输入为高电平时, 输出被禁用。

为了确保加电或断电期间的高阻抗状态, \overline{OE} 应通过一个上拉电阻器被连接至 V_{CC} ; 该电阻器的最小值由驱动器的电流吸收能力来决定。

输入可以由 3.3V 或 5V 器件驱动。此功能允许在 3.3V/5V 的混合系统环境中将该器件用作转换器。

封装信息

器件型号	封装 ⁽¹⁾	封装尺寸 ⁽²⁾	封装尺寸 ⁽³⁾
SN74LVC125A	BQA (WQFN, 14)	3mm × 2.5mm	3mm × 2.5mm
	D (SOIC, 14)	8.6mm × 6mm	8.65mm × 3.91mm
	DB (SSOP, 14)	6.20mm × 7.8mm	6.20mm × 5.30mm
	NS (SOP, 14)	10.2mm × 7.8mm	10.30mm × 5.30mm
	PW (TSSOP, 14)	5.00mm × 6.4mm	5.00mm × 4.40mm
	RGY (VQFN, 14)	3.50mm × 3.50mm	3.50mm × 3.50mm

(1) 更多相关信息, 请参阅第 11 节。

(2) 封装尺寸 (长 × 宽) 为标称值, 并包括引脚 (如适用)。

(3) 封装尺寸 (长 × 宽) 为标称值, 不包括引脚。

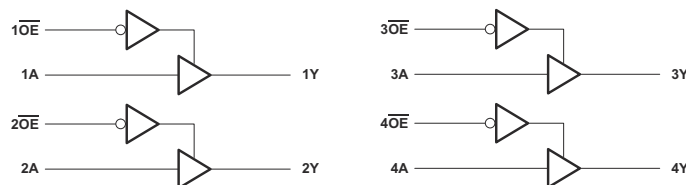

简化版原理图



内容

1 特性	1	6 参数测量信息	10
2 应用	1	7 详细说明	11
3 说明	1	7.1 概述.....	11
4 引脚配置和功能	3	7.2 功能方框图.....	11
5 规格	4	7.3 特性说明.....	11
5.1 绝对最大额定值.....	4	7.4 器件功能模式.....	11
5.2 ESD 等级.....	4	8 应用和实施	12
5.3 建议运行条件.....	5	8.1 典型应用.....	12
5.4 热性能信息.....	5	8.2 电源相关建议.....	13
5.5 电气特性.....	6	8.3 布局.....	13
5.6 开关特性.....	6	9 器件和文档支持	15
5.7 工作特性.....	7	9.1 文档支持.....	15
5.8 绝对最大额定值.....	7	9.2 接收文档更新通知.....	15
5.9 ESD 等级.....	7	9.3 支持资源.....	15
5.10 建议运行条件.....	7	9.4 商标.....	15
5.11 热性能信息.....	8	9.5 静电放电警告.....	15
5.12 电气特性.....	8	9.6 术语表.....	15
5.13 开关特性.....	9	10 修订历史记录	15
5.14 噪声特性.....	9	11 机械、封装和可订购信息	16

4 引脚配置和功能



图 4-1. D、DB、NS 或 PW 封装 (顶视图)



图 4-2. BQA 或 RGY 封装 (顶视图)

表 4-1. 引脚功能

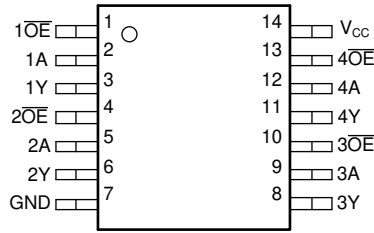
引脚		I/O	说明
名称	编号		
1OE	1	输入	输出使能
1A	2	输入	输入 A
1Y	3	输出	输出 Y
2OE	4	输入	输出使能
2A	5	输入	输入 A
2Y	6	输出	输出 Y
GND	7	—	地
3Y	8	输出	输出 Y
3A	9	输入	输入 A
3OE	10	输入	输出使能
4Y	11	输出	输出 Y
4A	12	输入	输入 A
4OE	13	输入	输出使能
V _{CC}	14	—	正电源

5 规格

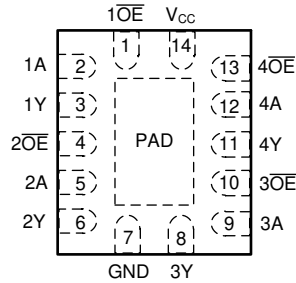
5.1 绝对最大额定值

在自然通风条件下的工作温度范围内测得（除非另有说明）⁽¹⁾

		最小值	最大值	单位
V _{CC}	电源电压范围	-0.5	6.5	V
V _I	输入电压范围 ⁽²⁾	-0.5	6.5	V
V _O	输出电压范围 ^{(2) (3)}	-0.5	V _{CC} + 0.5	V
I _{IK}	输入钳位电流	V _I < 0		-50 mA
I _{OK}	输出钳位电流	V _O < 0		-50 mA
I _O	持续输出电流			±50 mA
	通过 V _{CC} 或 GND 的持续电流			±100 mA
P _{tot}	功率耗散	T _A = -40°C 至 125°C ^{(4) (5)}		500 mW
T _{stg}	贮存温度范围	-65	150	°C

- (1) 应力超出绝对最大额定值下列出的值可能会对器件造成永久损坏。这些仅为应力等级，并不表示器件在这些条件下以及在 5.3 以外的任何其他条件下能够正常运行。长时间处于绝对最大额定条件下可能会影响器件的可靠性。
- (2) 如果遵守输入和输出电流额定值，则可能会超过输入和输出负电压额定值。
- (3) V_{CC} 的值在 5.3 表中提供。
- (4) 对于 D 封装：在 70°C 以上时，P_{tot} 值以 8mW/K 的幅度线性降额。
- (5) 对于 DB、NS 和 PW 封装：在 60°C 以上时，P_{tot} 值以 5.5mW/K 的幅度线性降额。

5.2 ESD 等级

参数	定义	值	单位
V _(ESD) 静电放电	人体放电模型 (HBM)，符合 ANSI/ESDA/JEDEC JS-001 标准，所有引脚 ⁽¹⁾	±2000	V
	充电器件模型 (CDM)，符合 JEDEC 规范 JESD22-C101，所有引脚 ⁽²⁾	±1000	

- (1) JEDEC 文档 JEP155 指出：500V HBM 支持在标准 ESD 控制流程下安全生产。
- (2) JEDEC 文档 JEP157 指出：250V CDM 支持在标准 ESD 控制流程下安全生产。

5.3 建议运行条件

在自然通风条件下的工作温度范围内测得 (除非另有说明) ⁽¹⁾

		T _A = 25°C		-40°C 至 85°C		-40°C 至 125°C		单位
		最小值	最大值	最小值	最大值	最小值	最大值	
V _{CC}	电源电压	运行		1.65	3.6	1.65	3.6	V
		仅数据保留		1.5		1.5		
V _{IH}	高电平 输入电压	V _{CC} = 1.65V 至 1.95V		0.65 × V _{CC}		0.65 × V _{CC}		V
		V _{CC} = 2.3V 至 2.7V		1.7		1.7		
		V _{CC} = 2.7V 至 3.6V		2		2		
V _{IL}	低电平 输入电压	V _{CC} = 1.65V 至 1.95V		0.35 × V _{CC}		0.35 × V _{CC}		V
		V _{CC} = 2.3V 至 2.7V		0.7		0.7		
		V _{CC} = 2.7V 至 3.6V		0.8		0.8		
V _I	输入电压	0	5.5	0	5.5	0	5.5	V
V _O	输出电压	0	V _{CC}	0	V _{CC}	0	V _{CC}	V
I _{OH}	高电平 输出电流	V _{CC} = 1.65V		-4		-4		mA
		V _{CC} = 2.3V		-8		-8		
		V _{CC} = 2.7V		-12		-12		
		V _{CC} = 3V		-24		-24		
I _{OL}	低电平 输出电流	V _{CC} = 1.65V		4		4		mA
		V _{CC} = 2.3V		8		8		
		V _{CC} = 2.7V		12		12		
		V _{CC} = 3V		24		24		
Δt/Δv 输入转换上升或下降速率		8		8		8		ns/V

(1) 器件所有的未使用输入必须保持在 V_{CC} 或 GND 以确保器件正常运行。请参阅 TI 应用报告 *CMOS 输入缓慢或悬空的影响*，文献编号 SCBA004。

5.4 热性能信息

热指标 ⁽¹⁾	SN74LVC125A						单位
	BQA (WQFN)	D (SOIC)	DB (SSOP)	NS (SOP)	PW (TSSOP)	RGY (VQFN)	
	14 引脚	14 引脚	14 引脚	14 引脚	14 引脚	14 引脚	
R _{θJA} 结至环境热阻	102.3	86	140.4	123.8	150.8	92.1	°C/W

(1) 有关新旧热指标的更多信息，请参阅 [半导体和 IC 封装热指标](#) 应用手册。

5.5 电气特性

在自然通风条件下的建议运行温度范围内测得 (除非另有说明)

参数	测试条件	V _{CC}	T _A = 25°C			-40°C 至 85°C		-40°C 至 125°C		单位
			最小值	典型值	最大值	最小值	最大值	最小值	最大值	
V _{OH}	I _{OH} = -100 μA	1.65V 至 3.6V	V _{CC} - 0.2			V _{CC} - 0.2		V _{CC} - 0.3		V
	I _{OH} = -4mA	1.65V	1.29			1.2		1.05		
	I _{OH} = -8mA	2.3V	1.9			1.7		1.55		
	I _{OH} = -12mA	2.7V	2.2			2.2		2.05		
		3V	2.4			2.4		2.25		
I _{OH} = -24mA	3V	2.3			2.2		2			
V _{OL}	I _{OL} = 100 μA	1.65V 至 3.6V	0.1			0.2		0.3		V
	I _{OL} = 4mA	1.65V	0.24			0.45		0.6		
	I _{OL} = 8mA	2.3V	0.3			0.7		0.75		
	I _{OL} = 12mA	2.7V	0.4			0.4		0.6		
	I _{OL} = 24mA	3V	0.55			0.55		0.8		
I _I	V _I = 5.5V 或 GND	3.6V	±1			±5		±20		μA
I _{OZ}	V _O = V _{CC} 或 GND	3.6V	±1			±10		±20		μA
I _{CC}	V _I = V _{CC} 或 GND , I _O = 0	3.6V	1			10		40		μA
ΔI _{CC}	一个输入电压为 V _{CC} - 0.6V , 其他输入电压为 V _{CC} 或 GND	2.7V 至 3.6V	500			500		5000		μA
C _i	V _I = V _{CC} 或 GND	3.3V	5							pF

5.6 开关特性

在自然通风条件下的建议工作温度范围内测得 (除非另有说明) (请参阅负载电路和电压波形)

参数	从 (输入)	至 (输出)	V _{CC}	T _A = 25°C			-40°C 至 85°C		-40°C 至 125°C		单位
				最小值	典型值	最大值	最小值	最大值	最小值	最大值	
t _{pd}	A	Y	1.8V ± 0.15V	1	4.5	11.8	1	12.3	1	13.8	ns
			2.5V ± 0.2V	1	2.7	5.8	1	6.3	1	8.4	
			2.7V	1	3	5.3	1	5.5	1	7	
			3.3V ± 0.3V	1	2.5	4.6	1	4.8	1	6	
t _{en}	OE	Y	1.8V ± 0.15V	1	4.3	13.8	1	14.3	1	15.8	ns
			2.5V ± 0.2V	1	2.7	6.9	1	7.4	1	9.5	
			2.7V	1	3.3	6.4	1	6.6	1	8.5	
			3.3V ± 0.3V	1	2.4	5.2	1	5.4	1	7	
t _{dis}	OE	Y	1.8V ± 0.15V	1	4.3	10.6	1	11.1	1	12.6	ns
			2.5V ± 0.2V	1	2.2	5.1	1	5.6	1	7.7	
			2.7V	1	2.5	4.8	1	5	1	6.5	
			3.3V ± 0.3V	1	2.4	4.4	1	4.6	1	6	
t _{sk(o)}			3.3V ± 0.3V				1		1.5	ns	

5.7 工作特性

$T_A = 25^\circ\text{C}$

参数		测试条件	V_{CC}	典型值	单位
C_{pd}	每个栅极的功率耗散电容	f = 10MHz	1.8V	7.4	pF
			2.5V	11.3	
			3.3V	15	

5.8 绝对最大额定值

在自然通风条件下的工作温度范围内测得 (除非另有说明) (1)

		最小值	最大值	单位
V_{CC}	电源电压范围	-0.5	6.5	V
V_I	输入电压范围(2)	-0.5	6.5	V
V_O	输出电压范围(2)	-0.5	$V_{CC} + 0.5$	V
I_{IK}	输入钳位电流	$V_I < 0\text{V}$	-50	mA
I_{OK}	输出钳位电流	$V_O < 0\text{V}$	-50	mA
I_O	持续输出电流		± 50	mA
I_O	通过 V_{CC} 或 GND 的持续输出电流		± 100	mA
T_J	结温	-65	150	$^\circ\text{C}$
T_{stg}	贮存温度	-65	150	$^\circ\text{C}$

- (1) 超出绝对最大额定值运行可能会对器件造成损坏。绝对最大额定值并不表示器件在这些条件下或在建议运行条件以外的任何其他条件下能够正常运行。如果在建议运行条件之外但在绝对最大额定值范围内短暂运行, 器件可能不会受到损坏, 但可能无法完全正常工作。以这种方式运行器件可能会影响器件的可靠性、功能和性能, 并缩短器件寿命。
- (2) 如果遵守输入和输出电流额定值, 输入和输出电压可超过额定值。

5.9 ESD 等级

		值	单位
$V_{(ESD)}$	静电放电	人体放电模型 (HBM), 符合 ANSI/ESDA/JEDEC JS-001 标准(1)	± 2000
		充电器件模型 (CDM), 符合 ANSI/ESDA/JEDEC JS-002 标准(2)	± 1000

- (1) JEDEC 文档 JEP155 指出: 500V HBM 能够在标准 ESD 控制流程下安全生产。
- (2) JEDEC 文档 JEP157 指出: 250V CDM 能够在标准 ESD 控制流程下安全生产。

5.10 建议运行条件

在自然通风条件下的工作温度范围内测得 (除非另有说明)

规格	说明	条件	最小值	最大值	单位
V_{CC}	电源电压		1.1	3.6	V
V_I	输入电压			5.5	V
V_O	输出电压	(高电平或低电平状态)		V_{CC}	V
I_{OH}	高电平输出电流	$V_{CC} = 1.8\text{V}$		-4	mA
		$V_{CC} = 2.3\text{V}$		-8	
		$V_{CC} = 2.7\text{V}$		-12	
		$V_{CC} = 3\text{V}$		-24	
I_{OL}	低电平输出电流	$V_{CC} = 1.8\text{V}$		4	mA
		$V_{CC} = 2.3\text{V}$		8	
		$V_{CC} = 2.7\text{V}$		12	
		$V_{CC} = 3\text{V}$		24	

在自然通风条件下的工作温度范围内测得（除非另有说明）

规格	说明	条件	最小值	最大值	单位
$\Delta t / \Delta v$	输入转换上升或下降速率			10	ns/V
T_A	自然通风条件下的工作温度范围		-40	125	°C
V_{IH}	高电平输入电压	$V_{CC} = 1.1\text{ V}$	0.75		V
V_{IH}	高电平输入电压	$V_{CC} = 1.2\text{ V}$	0.78		V
V_{IH}	高电平输入电压	$V_{CC} = 1.5\text{ V}$	0.975		V
V_{IH}	高电平输入电压	$V_{CC} = 1.65\text{ V}$	1.075		V
V_{IH}	高电平输入电压	$V_{CC} = 1.95\text{ V}$	1.2675		V
V_{IH}	高电平输入电压	$V_{CC} = 2.3\text{ V}$	1.7		V
V_{IH}	高电平输入电压	$V_{CC} = 2.7\text{ V}$	1.7		V
V_{IH}	高电平输入电压	$V_{CC} = 3.6\text{ V}$	2		V
V_{IL}	低电平输入电压	$V_{CC} = 1.1\text{ V}$		0.40	V
V_{IL}	低电平输入电压	$V_{CC} = 1.2\text{ V}$		0.42	V
V_{IL}	低电平输入电压	$V_{CC} = 1.5\text{ V}$		0.525	V
V_{IL}	低电平输入电压	$V_{CC} = 1.65\text{ V}$		0.5775	V
V_{IL}	低电平输入电压	$V_{CC} = 1.95\text{ V}$		0.6825	V
V_{IL}	低电平输入电压	$V_{CC} = 2.3\text{ V}$		0.7	V
V_{IL}	低电平输入电压	$V_{CC} = 2.7\text{ V}$		0.7	V
V_{IL}	低电平输入电压	$V_{CC} = 3.6\text{ V}$		0.8	V

5.11 热性能信息

热指标 ⁽¹⁾		封装选项			单位
		PW (TSSOP)	D (SOIC)	BQA (WQFN)	
		14 引脚	14 引脚	14 引脚	
$R_{\theta JA}$	结至环境热阻	150.8	127.8	102.3	°C/W
$R_{\theta JC(top)}$	结至外壳（顶部）热阻	78.3	81.9	96.8	°C/W
$R_{\theta JB}$	结至电路板热阻	93.8	84.4	70.9	°C/W
Ψ_{JT}	结至顶部特征参数	24.7	39.6	16.6	°C/W
Y_{JB}	结至电路板特征参数	93.2	83.9	70.9	°C/W
$R_{\theta JC(bot)}$	结至外壳（底部）热阻	-	-	50.1	°C/W

(1) 有关新旧热指标的更多信息，请参阅[半导体和 IC 封装热指标](#)应用报告。

5.12 电气特性

在自然通风条件下的工作温度范围内测得（除非另有说明）

参数	测试条件	V_{CC}	-40°C 至 125°C			单位
			最小值	典型值	最大值	
V_{OH}	$I_{OH} = -100\ \mu\text{A}$	1.1V 至 3.6V	$V_{CC} - 0.2$			V
V_{OH}	$I_{OH} = -4\ \text{mA}$	1.65 V	1.2			V
V_{OH}	$I_{OH} = -8\ \text{mA}$	2.3 V	1.75			V
V_{OH}	$I_{OH} = -12\ \text{mA}$	2.7 V	2.2			V
V_{OH}		3 V	2.4			V
V_{OH}	$I_{OH} = -24\ \text{mA}$	3 V	2.2			V
V_{OL}	$I_{OH} = 100\ \mu\text{A}$	1.1 V 至 3.6V	0.15			V
V_{OL}	$I_{OH} = 4\ \text{mA}$	1.65 V	0.45			V
V_{OL}	$I_{OH} = 8\ \text{mA}$	2.3 V	0.7			V

在自然通风条件下的工作温度范围内测得 (除非另有说明)

参数	测试条件	V _{CC}	-40°C 至 125°C			单位
			最小值	典型值	最大值	
V _{OL}	I _{OH} = 12 mA	2.7 V			0.4	V
V _{OL}	I _{OH} = 24 mA	3 V			0.55	V
I _I	V _I = V _{CC} 或 GND	3.6 V			±5	μA
I _{off}	V _I 或 V _O = V _{CC}	0 V			±10	μA
I _{OZ}	V _O = V _{CC} 或 GND	3.6 V			±15	μA
I _{CC}	V _I = V _{CC} 或 GND , I _O = 0	3.6 V			40	μA
ΔI _{CC}	一个输入电压为 V _{CC} 至 0.6 V , 其他输入电压为 V _{CC} 或 GND	2.7 V 至 3.6V			500	μA
C _I	V _I =V _{CC} 或 GND	3.3V			4.9	pF
C _O	V _O = V _{CC} 或 GND	3.3V			6.3	pF
C _{PD}	f = 10 MHz	1.8 V			31	pF
C _{PD}	f = 10 MHz	2.5 V			31	pF
C _{PD}	f = 10 MHz	3.3V			32	pF
C _{PD}	输出已禁用, f = 10MHz	1.8 V				pF
		2.5 V				
		3.3V				

5.13 开关特性

在自然通风条件下的工作温度范围内；典型值在 T_A = 25°C 时测得 (除非另有说明)。请参阅 [参数测量信息](#)

参数	从 (输入)	到 (输出)	负载电容	V _{CC}	-40°C 至 125°C			单位
					最小值	典型值	最大值	
t _{pd}	A、B 或 C	Y	C _L = 15pF	1.2 V ± 0.1 V	12	23	ns	
			C _L = 15pF	1.5 V ± 0.12 V	9	12		
t _{pd}	A、B 或 C	Y	C _L = 30pF	1.8 V ± 0.15 V		10.2	ns	
			C _L = 30pF	2.5 V ± 0.2 V		6.9		
			C _L = 50pF	2.7V		4.8		
			C _L = 50pF	3.3V ± 0.3V		4.1		
t _{sk(o)}				3.3V ± 0.3V		1.5	ns	

5.14 噪声特性

V_{CC} = 3.3 V , C_L = 50pF , T_A = 25°C

参数	说明	最小值	典型值	最大值	单位
V _{OL(P)}	安静输出, 最大动态 V _{OL}			0.8	V
V _{OL(V)}	安静输出, 最小动态 V _{OL}	-0.8	-0.3		V
V _{OH(V)}	安静输出, 最小动态 V _{OH}	2.2	3.3		V
V _{IH(D)}	高电平动态输入电压	2.0			V
V _{IL(D)}	低电平动态输入电压			0.8	V

6 参数测量信息

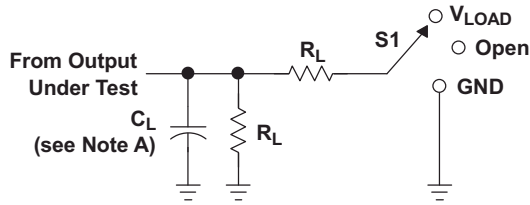

LOAD CIRCUIT

TEST	S1
t_{PLH}/t_{PHL}	Open
t_{PLZ}/t_{PZL}	V_{LOAD}
t_{PHZ}/t_{PZH}	GND

V_{CC}	INPUTS		V_M	V_{LOAD}	C_L	R_L	V_{Δ}
	V_I	t_r/t_f					
$1.8\text{ V} \pm 0.15\text{ V}$	V_{CC}	$\leq 2\text{ ns}$	$V_{CC}/2$	$2 \times V_{CC}$	30 pF	1 k Ω	0.15 V
$2.5\text{ V} \pm 0.2\text{ V}$	V_{CC}	$\leq 2\text{ ns}$	$V_{CC}/2$	$2 \times V_{CC}$	30 pF	500 Ω	0.15 V
2.7 V	2.7 V	$\leq 2.5\text{ ns}$	1.5 V	6 V	50 pF	500 Ω	0.3 V
$3.3\text{ V} \pm 0.3\text{ V}$	2.7 V	$\leq 2.5\text{ ns}$	1.5 V	6 V	50 pF	500 Ω	0.3 V

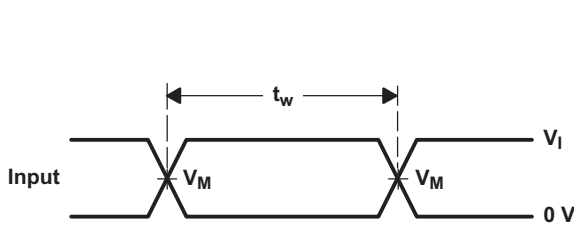

VOLTAGE WAVEFORMS
PULSE DURATION

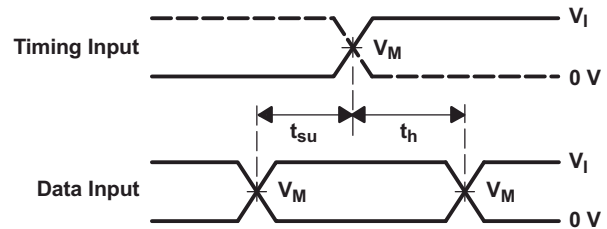

VOLTAGE WAVEFORMS
SETUP AND HOLD TIMES

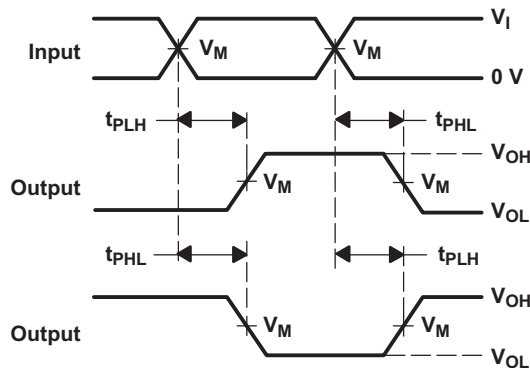

VOLTAGE WAVEFORMS
PROPAGATION DELAY TIMES
INVERTING AND NONINVERTING OUTPUTS

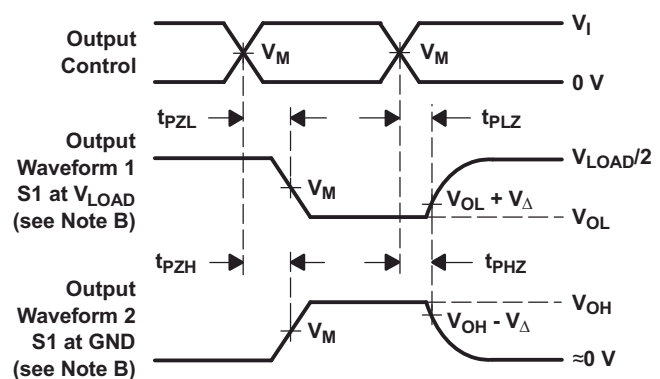

VOLTAGE WAVEFORMS
ENABLE AND DISABLE TIMES
LOW- AND HIGH-LEVEL ENABLING

- NOTES: A. C_L includes probe and jig capacitance.
 B. Waveform 1 is for an output with internal conditions such that the output is low, except when disabled by the output control. Waveform 2 is for an output with internal conditions such that the output is high, except when disabled by the output control.
 C. All input pulses are supplied by generators having the following characteristics: $PRR \leq 10\text{ MHz}$, $Z_O = 50\ \Omega$.
 D. The outputs are measured one at a time, with one transition per measurement.
 E. t_{PLZ} and t_{PHZ} are the same as t_{dis} .
 F. t_{PZL} and t_{PZH} are the same as t_{en} .
 G. t_{PLH} and t_{PHL} are the same as t_{pd} .
 H. All parameters and waveforms are not applicable to all devices.

图 6-1. 负载电路和电压波形

7 详细说明

7.1 概述

SN74LVC125A 器件是一款四通道总线缓冲门，具有独立的线路驱动器和三态输出。当每个输出的相关输出使能 (\overline{OE}) 输入为高电平时，输出被禁用。当 \overline{OE} 为低电平时，相应的逻辑门会将来自 A 输入的数据传递到 Y 输出。为确保在上电或下电期间均处于高阻态，应将 OE 通过一个上拉电阻连接至 V_{CC} ；该电阻的最小阻值取决于驱动器的拉电流能力。

7.2 功能方框图

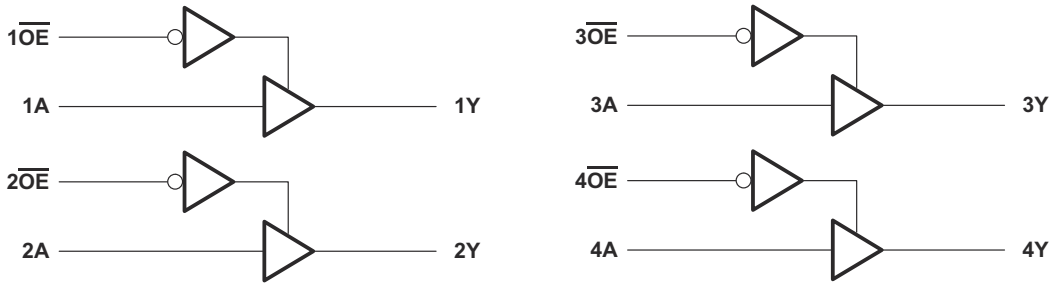

7.3 特性说明

- 宽工作电压范围
 - 可在 1.65V 至 5.5V 范围内工作
- 支持升降压转换
- 输入电压高达 5.5V

7.4 器件功能模式

表 7-1. 功能表

输入		输出 Y
\overline{OE}	A	
L	H	H
L	L	L
H	X	Z

8 应用和实施

备注

以下应用部分中的信息不属于 TI 器件规格的范围，TI 不担保其准确性和完整性。TI 的客户应负责确定器件是否适用于其应用。客户应验证并测试其设计，以确保系统功能。

8.1 典型应用



图 8-1. 典型应用原理图

8.1.1 设计要求

此器件采用 CMOS 技术并具有平衡输出驱动。注意避免总线争用，因为它可以驱动超过最大限制的电流。高驱动也会在轻负载时产生快速边缘，因此应考虑布线和负载条件以防止振铃。

8.1.2 详细设计过程

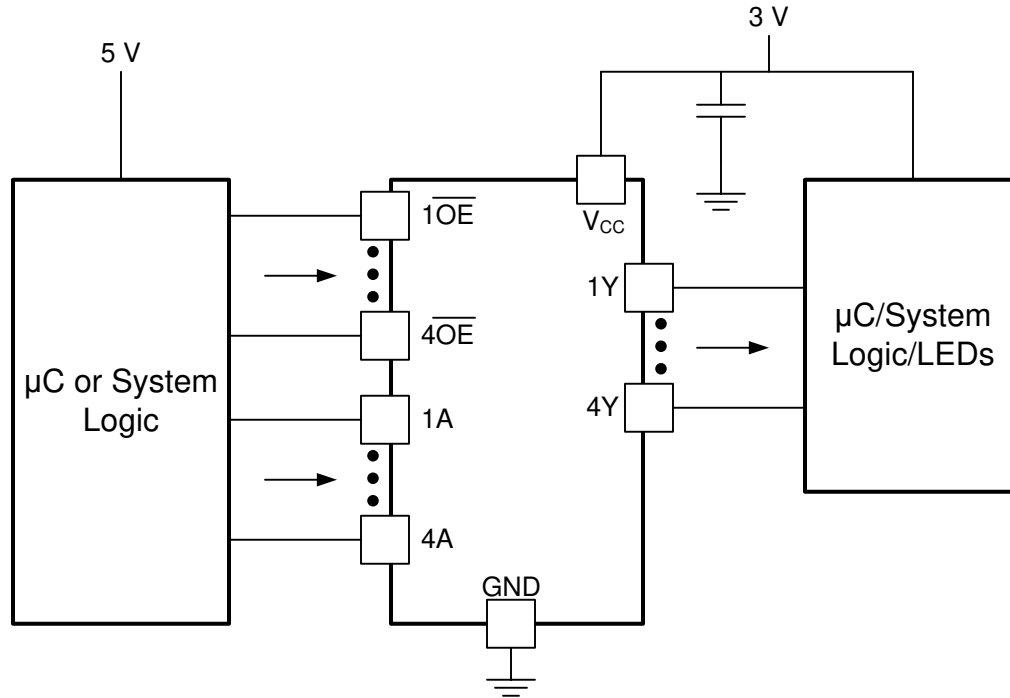
1. 建议的输入条件：

- 有关上升时间和下降时间规格，请参阅 [节 5.3](#) 表中的 ($\Delta t/\Delta V$)。
- 有关指定的高电平和低电平，请参阅 [节 5.3](#) 表中的 (V_{IH} 和 V_{IL})。
- 输入可耐受过压，因此可在任何有效的 V_{CC} 下高达 [节 5.3](#) 表中的 (V_I 最大值)。

2. 建议的输出条件：

- 每路输出的负载电流不应超过 (I_O 最大值)，且不能超过该器件的总电流 (通过 V_{CC} 或 GND 的持续电流)。这些限值位于 [节 5.1](#) 表中。
- 输出不应被拉至高于 V_{CC} 。
- 如果用户希望降低输出边沿信号的速度或限制输出电流，则可以在输出端使用串联电阻器。

8.1.3 应用曲线



图 8-2. 输出驱动电流 (I_{OL})
与低电平输出电压 (V_{OL}) 间的关系



图 8-3. 输出驱动电流 (I_{OH})
与高电平输出电压 (V_{OH}) 间的关系

8.2 电源相关建议

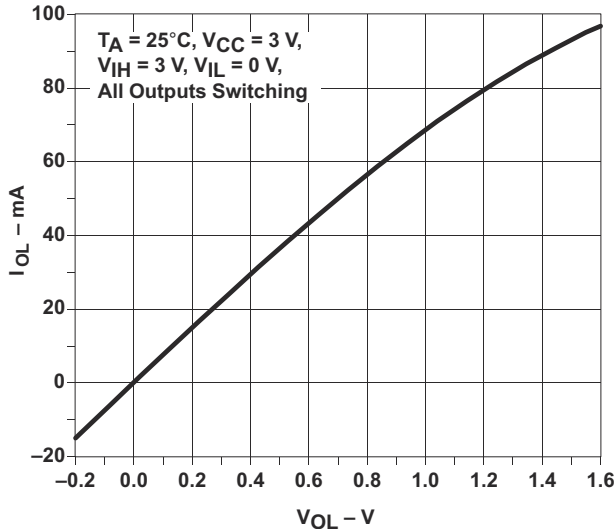
电源可以是 [表 5.3](#) 中最小和最大电源电压额定值之间的任意电压。

每个 V_{CC} 引脚应具有一个良好的旁路电容器，以防止功率干扰。对于单电源器件，建议使用 $0.1 \mu\text{f}$ ；如果有多个 V_{CC} 引脚，则建议每个电源引脚使用 $0.01 \mu\text{f}$ 或 $0.022 \mu\text{f}$ 。可以并联多个旁路电容器以抑制不同的噪声频率。 $0.1 \mu\text{f}$ 和 $1 \mu\text{f}$ 通常并联使用。为了获得更佳效果，旁路电容器应尽可能靠近电源引脚安装。

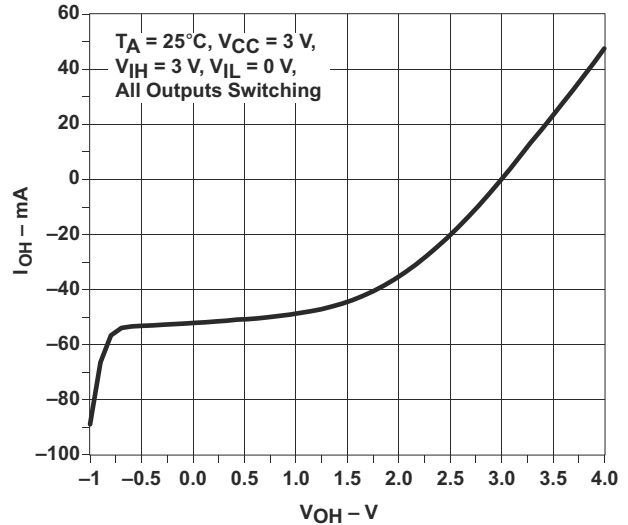
8.3 布局

8.3.1 布局指南

当使用多位逻辑器件时，输入不应悬空。在许多情况下，数字逻辑器件的功能或部分功能未被使用。例如，在仅使用三输入与门的两个输入，或仅使用 4 个缓冲门中的 3 个时。此类输入引脚不应悬空，因为外部连接处的未定义电压会导致未定义的运行状态。

[图 1-1](#) 指定了在所有情况下都必须遵守的规则。数字逻辑器件的所有未使用输入必须连接至一个高或低偏置以防止悬空。应为任何特定未使用输入施加的逻辑电平取决于器件的功能。通常，将这些输入连接到 GND 或 V_{CC} ，具体取决于哪种更合理或更方便。

8.3.2 布局示例



图 8-4. SN74LVC125A 的示例布局

9 器件和文档支持

9.1 文档支持

9.1.1 相关文档

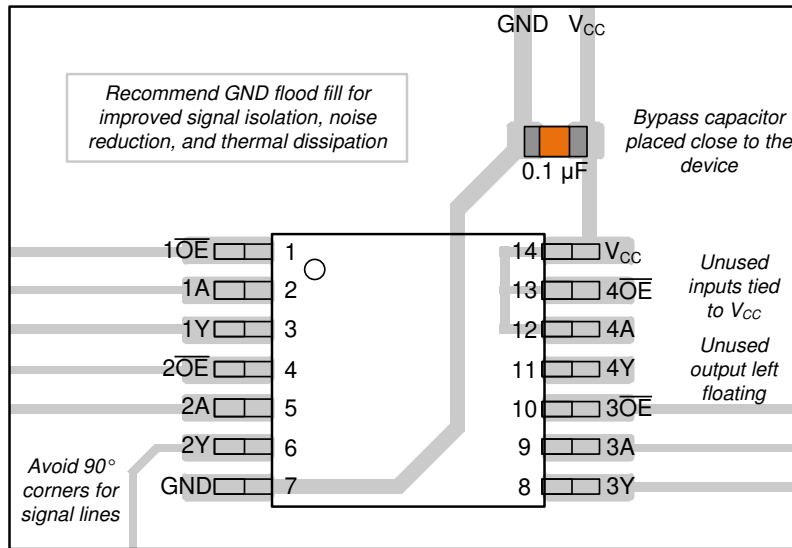
下表列出了快速访问链接。类别包括技术文档、支持和社区资源、工具和软件，以及申请样片或购买产品的快速链接。

表 9-1. 相关链接

器件	产品文件夹	样片与购买	技术文档	工具和软件	支持和社区
SN74LVC125A	点击此处	点击此处	点击此处	点击此处	点击此处

9.2 接收文档更新通知

要接收文档更新通知，请导航至 ti.com 上的器件产品文件夹。点击 [通知](#) 进行注册，即可每周接收产品信息更改摘要。有关更改的详细信息，请查看任何已修订文档中包含的修订历史记录。

9.3 支持资源

[TI E2E™ 中文支持论坛](#) 是工程师的重要参考资料，可直接从专家处获得快速、经过验证的解答和设计帮助。搜索现有解答或提出自己的问题，获得所需的快速设计帮助。

链接的内容由各个贡献者“按原样”提供。这些内容并不构成 TI 技术规范，并且不一定反映 TI 的观点；请参阅 TI 的 [使用条款](#)。

9.4 商标

TI E2E™ is a trademark of Texas Instruments.

所有商标均为其各自所有者的财产。

9.5 静电放电警告



静电放电 (ESD) 会损坏这个集成电路。德州仪器 (TI) 建议通过适当的预防措施处理所有集成电路。如果不遵守正确的处理和安装程序，可能会损坏集成电路。

ESD 的损坏小至导致微小的性能降级，大至整个器件故障。精密的集成电路可能更容易受到损坏，这是因为非常细微的参数更改都可能会导致器件与其发布的规格不相符。

9.6 术语表

[TI 术语表](#) 本术语表列出并解释了术语、首字母缩略词和定义。

10 修订历史记录

Changes from Revision R (February 2024) to Revision S (May 2024)	Page
• 更新了 R θ JA 值：DB = 96 更新至 140.4，NS = 76 更新至 123.8，PW = 113 更新至 150.8，RGY = 47 更新至 92.1；更新了 DB、NS、PW 和 RGY 封装的 R θ JC(top)、R θ JB、 Ψ JT、 Ψ JB 和 R θ JC(bot)，所有值均以 °C/W 为单位.....	5

Changes from Revision Q (January 2015) to Revision R (February 2024)	Page
• 将 器件信息 表更新为 封装信息 、添加了 ESD 等级 表并更新了数据表的结构布局.....	1
• 向 封装信息 表中添加了 BQA 封装和封装尺寸.....	1
• 向 引脚配置和功能 表添加了 BQA 封装.....	3
• 向 热性能信息 表添加了 BQA 封装.....	5

11 机械、封装和可订购信息

以下页面包含机械、封装和可订购信息。这些信息是指定器件的最新可用数据。数据如有变更，恕不另行通知，且不会对此文档进行修订。有关此数据表的浏览器版本，请查阅左侧的导航栏。

PACKAGING INFORMATION

Orderable Device	Status (1)	Package Type	Package Drawing	Pins	Package Qty	Eco Plan (2)	Lead finish/ Ball material (6)	MSL Peak Temp (3)	Op Temp (°C)	Device Marking (4/5)	Samples
SN74LVC125ABQAR	ACTIVE	WQFN	BQA	14	3000	RoHS & Green	NIPDAU	Level-1-260C-UNLIM	-40 to 125	LV125A	Samples
SN74LVC125AD	ACTIVE	SOIC	D	14	50	RoHS & Green	NIPDAU	Level-1-260C-UNLIM	-40 to 125	LVC125A	Samples
SN74LVC125ADBR	ACTIVE	SSOP	DB	14	2000	RoHS & Green	NIPDAU	Level-1-260C-UNLIM	-40 to 125	LC125A	Samples
SN74LVC125ADBRG4	ACTIVE	SSOP	DB	14	2000	RoHS & Green	NIPDAU	Level-1-260C-UNLIM	-40 to 125	LC125A	Samples
SN74LVC125ADE4	ACTIVE	SOIC	D	14	50	RoHS & Green	NIPDAU	Level-1-260C-UNLIM	-40 to 125	LVC125A	Samples
SN74LVC125ADG4	ACTIVE	SOIC	D	14	50	RoHS & Green	NIPDAU	Level-1-260C-UNLIM	-40 to 125	LVC125A	Samples
SN74LVC125ADR	ACTIVE	SOIC	D	14	2500	RoHS & Green	NIPDAU SN	Level-1-260C-UNLIM	-40 to 125	LVC125A	Samples
SN74LVC125ADRE4	ACTIVE	SOIC	D	14	2500	RoHS & Green	NIPDAU	Level-1-260C-UNLIM	-40 to 125	LVC125A	Samples
SN74LVC125ADRG3	ACTIVE	SOIC	D	14	2500	RoHS & Green	SN	Level-1-260C-UNLIM	-40 to 125	LVC125A	Samples
SN74LVC125ADRG4	ACTIVE	SOIC	D	14	2500	RoHS & Green	NIPDAU	Level-1-260C-UNLIM	-40 to 125	LVC125A	Samples
SN74LVC125ADT	ACTIVE	SOIC	D	14	250	RoHS & Green	NIPDAU	Level-1-260C-UNLIM	-40 to 125	LVC125A	Samples
SN74LVC125ADTG4	ACTIVE	SOIC	D	14	250	RoHS & Green	NIPDAU	Level-1-260C-UNLIM	-40 to 125	LVC125A	Samples
SN74LVC125ANSR	ACTIVE	SO	NS	14	2000	RoHS & Green	NIPDAU	Level-1-260C-UNLIM	-40 to 125	LVC125A	Samples
SN74LVC125APW	ACTIVE	TSSOP	PW	14	90	RoHS & Green	NIPDAU	Level-1-260C-UNLIM	-40 to 125	LC125A	Samples
SN74LVC125APWE4	ACTIVE	TSSOP	PW	14	90	RoHS & Green	NIPDAU	Level-1-260C-UNLIM	-40 to 125	LC125A	Samples
SN74LVC125APWG4	ACTIVE	TSSOP	PW	14	90	RoHS & Green	NIPDAU	Level-1-260C-UNLIM	-40 to 125	LC125A	Samples
SN74LVC125APWR	ACTIVE	TSSOP	PW	14	2000	RoHS & Green	NIPDAU SN	Level-1-260C-UNLIM	-40 to 125	LC125A	Samples
SN74LVC125APWRE4	ACTIVE	TSSOP	PW	14	2000	RoHS & Green	NIPDAU	Level-1-260C-UNLIM	-40 to 125	LC125A	Samples
SN74LVC125APWRG3	ACTIVE	TSSOP	PW	14	2000	RoHS & Green	SN	Level-1-260C-UNLIM		LC125A	Samples
SN74LVC125APWRG4	ACTIVE	TSSOP	PW	14	2000	RoHS & Green	NIPDAU	Level-1-260C-UNLIM	-40 to 125	LC125A	Samples

Orderable Device	Status (1)	Package Type	Package Drawing	Pins	Package Qty	Eco Plan (2)	Lead finish/ Ball material (6)	MSL Peak Temp (3)	Op Temp (°C)	Device Marking (4/5)	Samples
SN74LVC125APWT	ACTIVE	TSSOP	PW	14	250	RoHS & Green	NIPDAU	Level-1-260C-UNLIM	-40 to 125	LC125A	Samples
SN74LVC125APWTE4	ACTIVE	TSSOP	PW	14	250	RoHS & Green	NIPDAU	Level-1-260C-UNLIM	-40 to 125	LC125A	Samples
SN74LVC125APWTG4	ACTIVE	TSSOP	PW	14	250	RoHS & Green	NIPDAU	Level-1-260C-UNLIM	-40 to 125	LC125A	Samples
SN74LVC125ARGYR	ACTIVE	VQFN	RGY	14	3000	RoHS & Green	NIPDAU	Level-2-260C-1 YEAR	-40 to 125	LC125A	Samples

(1) The marketing status values are defined as follows:

ACTIVE: Product device recommended for new designs.

LIFEBUY: TI has announced that the device will be discontinued, and a lifetime-buy period is in effect.

NRND: Not recommended for new designs. Device is in production to support existing customers, but TI does not recommend using this part in a new design.

PREVIEW: Device has been announced but is not in production. Samples may or may not be available.

OBSOLETE: TI has discontinued the production of the device.

(2) **RoHS:** TI defines "RoHS" to mean semiconductor products that are compliant with the current EU RoHS requirements for all 10 RoHS substances, including the requirement that RoHS substance do not exceed 0.1% by weight in homogeneous materials. Where designed to be soldered at high temperatures, "RoHS" products are suitable for use in specified lead-free processes. TI may reference these types of products as "Pb-Free".

RoHS Exempt: TI defines "RoHS Exempt" to mean products that contain lead but are compliant with EU RoHS pursuant to a specific EU RoHS exemption.

Green: TI defines "Green" to mean the content of Chlorine (Cl) and Bromine (Br) based flame retardants meet JS709B low halogen requirements of <=1000ppm threshold. Antimony trioxide based flame retardants must also meet the <=1000ppm threshold requirement.

(3) MSL, Peak Temp. - The Moisture Sensitivity Level rating according to the JEDEC industry standard classifications, and peak solder temperature.

(4) There may be additional marking, which relates to the logo, the lot trace code information, or the environmental category on the device.

(5) Multiple Device Markings will be inside parentheses. Only one Device Marking contained in parentheses and separated by a "~" will appear on a device. If a line is indented then it is a continuation of the previous line and the two combined represent the entire Device Marking for that device.

(6) Lead finish/Ball material - Orderable Devices may have multiple material finish options. Finish options are separated by a vertical ruled line. Lead finish/Ball material values may wrap to two lines if the finish value exceeds the maximum column width.

Important Information and Disclaimer: The information provided on this page represents TI's knowledge and belief as of the date that it is provided. TI bases its knowledge and belief on information provided by third parties, and makes no representation or warranty as to the accuracy of such information. Efforts are underway to better integrate information from third parties. TI has taken and continues to take reasonable steps to provide representative and accurate information but may not have conducted destructive testing or chemical analysis on incoming materials and chemicals. TI and TI suppliers consider certain information to be proprietary, and thus CAS numbers and other limited information may not be available for release.

In no event shall TI's liability arising out of such information exceed the total purchase price of the TI part(s) at issue in this document sold by TI to Customer on an annual basis.

OTHER QUALIFIED VERSIONS OF SN74LVC125A :

- Automotive : [SN74LVC125A-Q1](#)
- Enhanced Product : [SN74LVC125A-EP](#)

NOTE: Qualified Version Definitions:

- Automotive - Q100 devices qualified for high-reliability automotive applications targeting zero defects
- Enhanced Product - Supports Defense, Aerospace and Medical Applications

TAPE AND REEL INFORMATION

QUADRANT ASSIGNMENTS FOR PIN 1 ORIENTATION IN TAPE

*All dimensions are nominal

Device	Package Type	Package Drawing	Pins	SPQ	Reel Diameter (mm)	Reel Width W1 (mm)	A0 (mm)	B0 (mm)	K0 (mm)	P1 (mm)	W (mm)	Pin1 Quadrant
SN74LVC125ABQAR	WQFN	BQA	14	3000	180.0	12.4	2.8	3.3	1.1	4.0	12.0	Q1
SN74LVC125ADBR	SSOP	DB	14	2000	330.0	16.4	8.35	6.6	2.4	12.0	16.0	Q1
SN74LVC125ADR	SOIC	D	14	2500	330.0	16.4	6.5	9.0	2.1	8.0	16.0	Q1
SN74LVC125ADRG3	SOIC	D	14	2500	330.0	16.8	6.5	9.5	2.3	8.0	16.0	Q1
SN74LVC125ADRG4	SOIC	D	14	2500	330.0	16.4	6.5	9.0	2.1	8.0	16.0	Q1
SN74LVC125ADRG4	SOIC	D	14	2500	330.0	16.4	6.5	9.0	2.1	8.0	16.0	Q1
SN74LVC125ADT	SOIC	D	14	250	330.0	16.4	6.5	9.0	2.1	8.0	16.0	Q1
SN74LVC125ANSR	SO	NS	14	2000	330.0	16.4	8.2	10.5	2.5	12.0	16.0	Q1
SN74LVC125APWR	TSSOP	PW	14	2000	330.0	12.4	6.9	5.6	1.6	8.0	12.0	Q1
SN74LVC125APWRG3	TSSOP	PW	14	2000	330.0	12.4	6.9	5.6	1.6	8.0	12.0	Q1
SN74LVC125APWRG4	TSSOP	PW	14	2000	330.0	12.4	6.9	5.6	1.6	8.0	12.0	Q1
SN74LVC125APWT	TSSOP	PW	14	250	330.0	12.4	6.9	5.6	1.6	8.0	12.0	Q1
SN74LVC125ARGYR	VQFN	RGY	14	3000	330.0	12.4	3.75	3.75	1.15	8.0	12.0	Q1

TAPE AND REEL BOX DIMENSIONS

*All dimensions are nominal

Device	Package Type	Package Drawing	Pins	SPQ	Length (mm)	Width (mm)	Height (mm)
SN74LVC125ABQAR	WQFN	BQA	14	3000	210.0	185.0	35.0
SN74LVC125ADBR	SSOP	DB	14	2000	356.0	356.0	35.0
SN74LVC125ADR	SOIC	D	14	2500	333.2	345.9	28.6
SN74LVC125ADRG3	SOIC	D	14	2500	364.0	364.0	27.0
SN74LVC125ADRG4	SOIC	D	14	2500	356.0	356.0	35.0
SN74LVC125ADRG4	SOIC	D	14	2500	333.2	345.9	28.6
SN74LVC125ADT	SOIC	D	14	250	210.0	185.0	35.0
SN74LVC125ANSR	SO	NS	14	2000	356.0	356.0	35.0
SN74LVC125APWR	TSSOP	PW	14	2000	356.0	356.0	35.0
SN74LVC125APWRG3	TSSOP	PW	14	2000	364.0	364.0	27.0
SN74LVC125APWRG4	TSSOP	PW	14	2000	356.0	356.0	35.0
SN74LVC125APWT	TSSOP	PW	14	250	356.0	356.0	35.0
SN74LVC125ARGYR	VQFN	RGY	14	3000	356.0	356.0	35.0

TUBE

*All dimensions are nominal

Device	Package Name	Package Type	Pins	SPQ	L (mm)	W (mm)	T (μm)	B (mm)
SN74LVC125AD	D	SOIC	14	50	506.6	8	3940	4.32
SN74LVC125ADE4	D	SOIC	14	50	506.6	8	3940	4.32
SN74LVC125ADG4	D	SOIC	14	50	506.6	8	3940	4.32
SN74LVC125APW	PW	TSSOP	14	90	530	10.2	3600	3.5
SN74LVC125APWE4	PW	TSSOP	14	90	530	10.2	3600	3.5
SN74LVC125APWG4	PW	TSSOP	14	90	530	10.2	3600	3.5

RGY (S-PVQFN-N14)

PLASTIC QUAD FLATPACK NO-LEAD



- NOTES:
- A. All linear dimensions are in millimeters. Dimensioning and tolerancing per ASME Y14.5M-1994.
 - B. This drawing is subject to change without notice.
 - C. QFN (Quad Flatpack No-Lead) package configuration.
 - D. The package thermal pad must be soldered to the board for thermal and mechanical performance.
 - E. See the additional figure in the Product Data Sheet for details regarding the exposed thermal pad features and dimensions.
 -  Pin 1 identifiers are located on both top and bottom of the package and within the zone indicated. The Pin 1 identifiers are either a molded, marked, or metal feature.
 - G. Package complies to JEDEC MO-241 variation BA.

RGY (S-PVQFN-N14)

PLASTIC QUAD FLATPACK NO-LEAD

THERMAL INFORMATION

This package incorporates an exposed thermal pad that is designed to be attached directly to an external heatsink. The thermal pad must be soldered directly to the printed circuit board (PCB). After soldering, the PCB can be used as a heatsink. In addition, through the use of thermal vias, the thermal pad can be attached directly to the appropriate copper plane shown in the electrical schematic for the device, or alternatively, can be attached to a special heatsink structure designed into the PCB. This design optimizes the heat transfer from the integrated circuit (IC).

For information on the Quad Flatpack No-Lead (QFN) package and its advantages, refer to Application Report, QFN/SON PCB Attachment, Texas Instruments Literature No. SLUA271. This document is available at www.ti.com.

The exposed thermal pad dimensions for this package are shown in the following illustration.



Bottom View

Exposed Thermal Pad Dimensions

4206353-2/P 03/14

NOTE: All linear dimensions are in millimeters

RGY (S-PVQFN-N14)

PLASTIC QUAD FLATPACK NO-LEAD



4208122-2/P 03/14

- NOTES:
- All linear dimensions are in millimeters.
 - This drawing is subject to change without notice.
 - Publication IPC-7351 is recommended for alternate designs.
 - This package is designed to be soldered to a thermal pad on the board. Refer to Application Note, Quad Flat-Pack QFN/SON PCB Attachment, Texas Instruments Literature No. SLUA271, and also the Product Data Sheets for specific thermal information, via requirements, and recommended board layout. These documents are available at www.ti.com <<http://www.ti.com>>.
 - Laser cutting apertures with trapezoidal walls and also rounding corners will offer better paste release. Customers should contact their board assembly site for stencil design recommendations. Refer to IPC 7525 for stencil design considerations.
 - Customers should contact their board fabrication site for minimum solder mask web tolerances between signal pads.

GENERIC PACKAGE VIEW

BQA 14

WQFN - 0.8 mm max height

2.5 x 3, 0.5 mm pitch

PLASTIC QUAD FLATPACK - NO LEAD

This image is a representation of the package family, actual package may vary.
Refer to the product data sheet for package details.

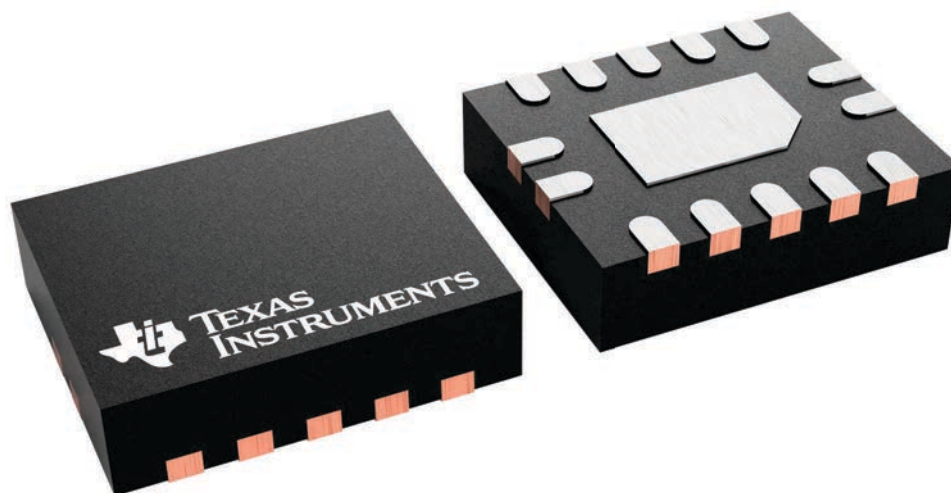

4227145/A

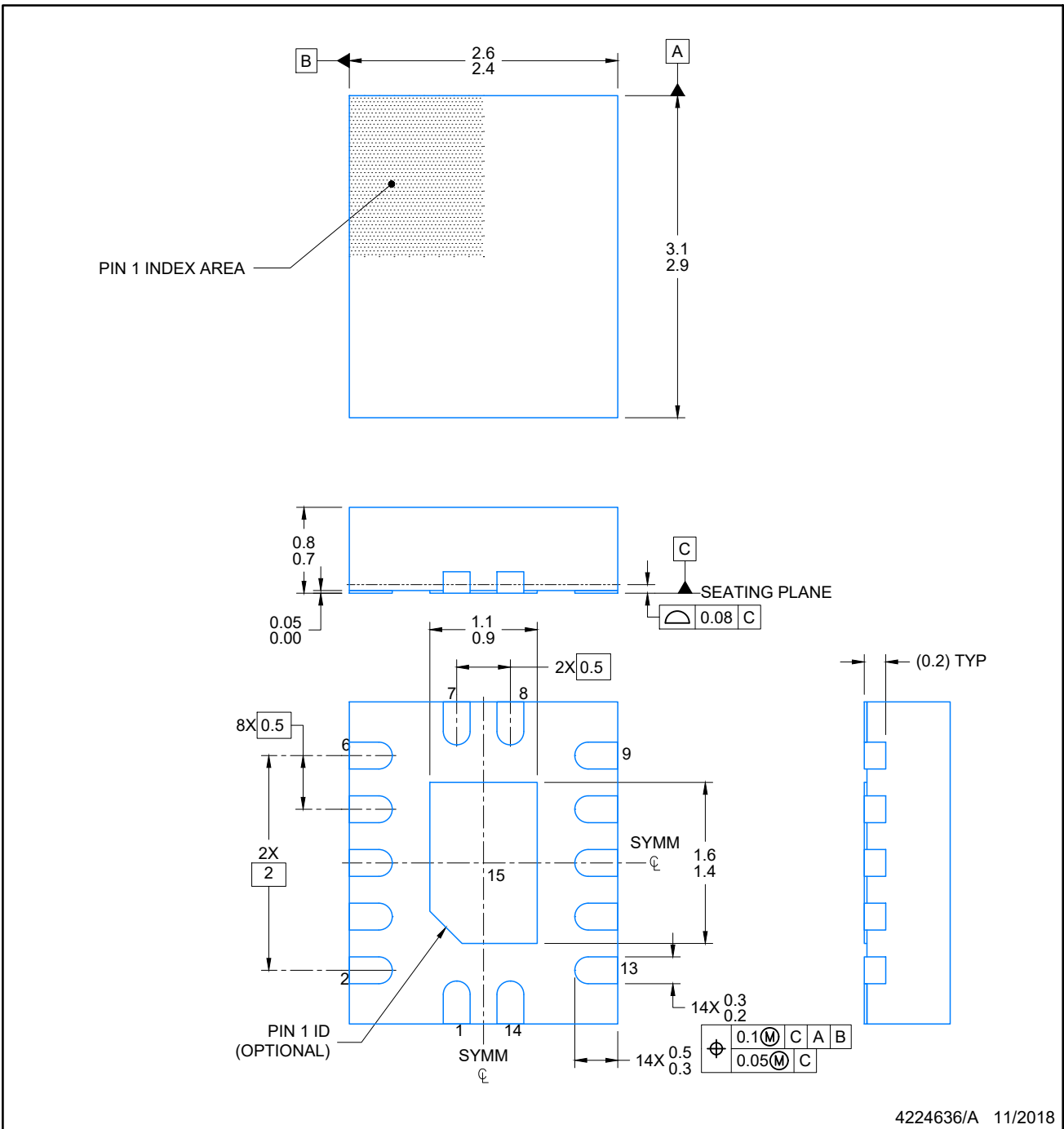

NOTES:

1. All linear dimensions are in millimeters. Any dimensions in parenthesis are for reference only. Dimensioning and tolerancing per ASME Y14.5M.
2. This drawing is subject to change without notice.
3. The package thermal pad must be soldered to the printed circuit board for optimal thermal and mechanical performance.

EXAMPLE BOARD LAYOUT

WQFN - 0.8 mm max height

BQA0014A

PLASTIC QUAD FLAT PACK-NO LEAD



LAND PATTERN EXAMPLE
EXPOSED METAL SHOWN
SCALE: 20X

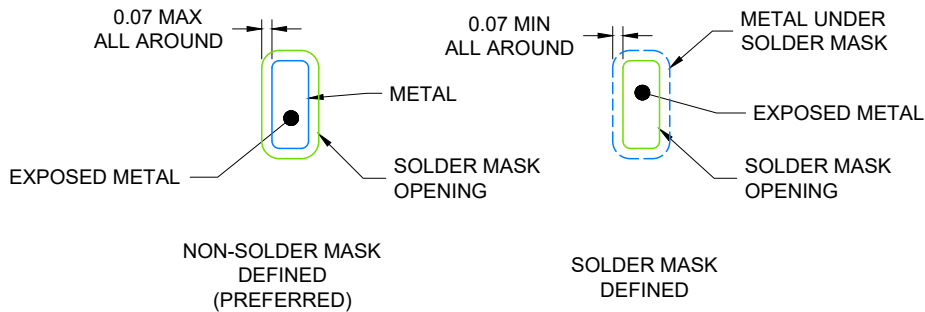

4224636/A 11/2018

NOTES: (continued)

4. This package is designed to be soldered to a thermal pad on the board. For more information, see Texas Instruments literature number SLUA271 (www.ti.com/lit/sluea271).
5. Vias are optional depending on application, refer to device data sheet. If any vias are implemented, refer to their locations shown on this view. It is recommended that vias under paste be filled, plugged or tented.

EXAMPLE STENCIL DESIGN

BQA0014A

WQFN - 0.8 mm max height

PLASTIC QUAD FLAT PACK-NO LEAD



SOLDER PASTE EXAMPLE
 BASED ON 0.125 mm THICK STENCIL

EXPOSED PAD
 88% PRINTED COVERAGE BY AREA
 SCALE: 20X

4224636/A 11/2018

NOTES: (continued)

- 6. Laser cutting apertures with trapezoidal walls and rounded corners may offer better paste release. IPC-7525 may have alternate design recommendations.

MECHANICAL DATA

NS (R-PDSO-G**)

PLASTIC SMALL-OUTLINE PACKAGE

14-PINS SHOWN



- NOTES:
- A. All linear dimensions are in millimeters.
 - B. This drawing is subject to change without notice.
 - C. Body dimensions do not include mold flash or protrusion, not to exceed 0,15.

DB0014A



PACKAGE OUTLINE

SSOP - 2 mm max height

SMALL OUTLINE PACKAGE



4220762/A 05/2024

NOTES:

- All linear dimensions are in millimeters. Any dimensions in parenthesis are for reference only. Dimensioning and tolerancing per ASME Y14.5M.
- This drawing is subject to change without notice.
- This dimension does not include mold flash, protrusions, or gate burrs. Mold flash, protrusions, or gate burrs shall not exceed 0.15 mm per side.
- Reference JEDEC registration MO-150.

EXAMPLE BOARD LAYOUT

DB0014A

SSOP - 2 mm max height

SMALL OUTLINE PACKAGE



LAND PATTERN EXAMPLE
EXPOSED METAL SHOWN
SCALE: 10X



4220762/A 05/2024

NOTES: (continued)

- 5. Publication IPC-7351 may have alternate designs.
- 6. Solder mask tolerances between and around signal pads can vary based on board fabrication site.

EXAMPLE STENCIL DESIGN

DB0014A

SSOP - 2 mm max height

SMALL OUTLINE PACKAGE



SOLDER PASTE EXAMPLE
BASED ON 0.125 mm THICK STENCIL
SCALE: 10X

4220762/A 05/2024

NOTES: (continued)

7. Laser cutting apertures with trapezoidal walls and rounded corners may offer better paste release. IPC-7525 may have alternate design recommendations.
8. Board assembly site may have different recommendations for stencil design.

D (R-PDSO-G14)

PLASTIC SMALL OUTLINE

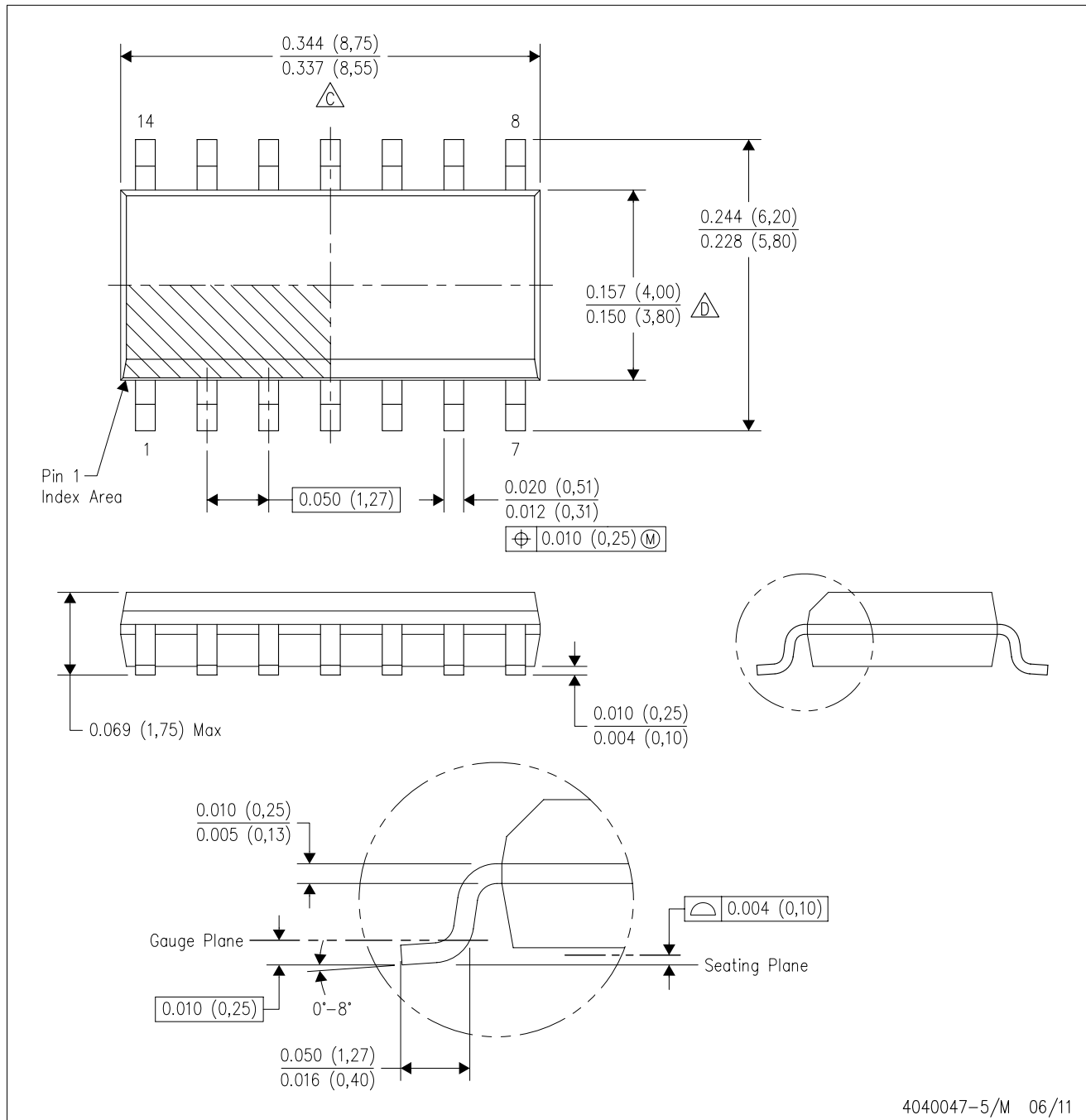

- NOTES:
- A. All linear dimensions are in inches (millimeters).
 - B. This drawing is subject to change without notice.
 -  Body length does not include mold flash, protrusions, or gate burrs. Mold flash, protrusions, or gate burrs shall not exceed 0.006 (0,15) each side.
 -  Body width does not include interlead flash. Interlead flash shall not exceed 0.017 (0,43) each side.
 - E. Reference JEDEC MS-012 variation AB.

D (R-PDSO-G14)

PLASTIC SMALL OUTLINE



4211283-3/E 08/12

- NOTES:
- All linear dimensions are in millimeters.
 - This drawing is subject to change without notice.
 - Publication IPC-7351 is recommended for alternate designs.
 - Laser cutting apertures with trapezoidal walls and also rounding corners will offer better paste release. Customers should contact their board assembly site for stencil design recommendations. Refer to IPC-7525 for other stencil recommendations.
 - Customers should contact their board fabrication site for solder mask tolerances between and around signal pads.

PW (R-PDSO-G14)

PLASTIC SMALL OUTLINE



4040064-3/G 02/11

- NOTES:
- A. All linear dimensions are in millimeters. Dimensioning and tolerancing per ASME Y14.5M-1994.
 - B. This drawing is subject to change without notice.
 - C. Body length does not include mold flash, protrusions, or gate burrs. Mold flash, protrusions, or gate burrs shall not exceed 0,15 each side.
 - D. Body width does not include interlead flash. Interlead flash shall not exceed 0,25 each side.
 - E. Falls within JEDEC MO-153

PW (R-PDSO-G14)

PLASTIC SMALL OUTLINE



- NOTES:
- All linear dimensions are in millimeters.
 - This drawing is subject to change without notice.
 - Publication IPC-7351 is recommended for alternate designs.
 - Laser cutting apertures with trapezoidal walls and also rounding corners will offer better paste release. Customers should contact their board assembly site for stencil design recommendations. Refer to IPC-7525 for other stencil recommendations.
 - Customers should contact their board fabrication site for solder mask tolerances between and around signal pads.

重要声明和免责声明

TI“按原样”提供技术和可靠性数据（包括数据表）、设计资源（包括参考设计）、应用或其他设计建议、网络工具、安全信息和其他资源，不保证没有瑕疵且不做任何明示或暗示的担保，包括但不限于对适销性、某特定用途方面的适用性或不侵犯任何第三方知识产权的暗示担保。

这些资源可供使用 TI 产品进行设计的熟练开发人员使用。您将自行承担以下全部责任：(1) 针对您的应用选择合适的 TI 产品，(2) 设计、验证并测试您的应用，(3) 确保您的应用满足相应标准以及任何其他功能安全、信息安全、监管或其他要求。

这些资源如有变更，恕不另行通知。TI 授权您仅可将这些资源用于研发本资源所述的 TI 产品的应用。严禁对这些资源进行其他复制或展示。您无权使用任何其他 TI 知识产权或任何第三方知识产权。您应全额赔偿因在这些资源的使用中对 TI 及其代表造成的任何索赔、损害、成本、损失和债务，TI 对此概不负责。

TI 提供的产品受 [TI 的销售条款](#) 或 [ti.com](#) 上其他适用条款/TI 产品随附的其他适用条款的约束。TI 提供这些资源并不会扩展或以其他方式更改 TI 针对 TI 产品发布的适用的担保或担保免责声明。

TI 反对并拒绝您可能提出的任何其他或不同的条款。

邮寄地址：Texas Instruments, Post Office Box 655303, Dallas, Texas 75265
Copyright © 2024，德州仪器 (TI) 公司