

具有 I²C 和 SMBus 接口且采用行业标准 LM75 外形尺寸和引脚输出的 TMP1075 温度传感器

1 特性

- 温度精度：
 - 55°C 至 +125°C 范围内为 $\pm 0.25^\circ\text{C}$ (典型值)
 - 40°C 至 +110°C 范围内为 $\pm 1^\circ\text{C}$ (最大值)
 - 55°C 至 +125°C 范围内为 $\pm 2^\circ\text{C}$ (最大值)
- 低功耗：
 - 2.7 μA 平均电流
 - 0.37 μA 关断电流
- 电源电压范围选项：1.62V 至 5.5V
- 温度与电源无关
- 数字接口：SMBus、I²C
- 软件与业界通用 LM75 和 TMP75 兼容
- 可兼容 I³C 混合快速模式总线
- 分辨率：12 位
- 支持高达 32 个 I²C 地址
- 警报引脚功能
- NIST 可追溯性

2 应用

- 电源温度监控
- 计算机外设过热保护
- 笔记本电脑
- 手机
- 电池管理
- 办公机器
- 恒温器控制
- 环境监测和 HVAC
- 机电器件温度

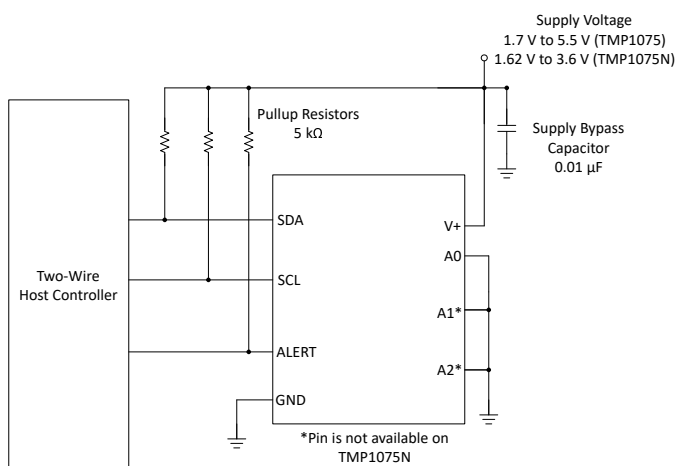

简化版原理图

3 说明

TMP1075 精度最高，功耗最低，是行业标准 LM75 和 TMP75 数字温度传感器的替代产品。TMP1075 采用 SOIC-8、VSSOP-8、WSON-8 和 SOT563-6 封装，可提供引脚对引脚及软件兼容，以便快速升级任何现有 xx75 设计。TMP1075 新增的封装为 2.0 × 2.0mm DFN 和 1.6 × 1.6mm SOT563-6，与 SOIC 封装相比，印刷电路板 (PCB) 封装面积分别减少了 82% 和 89%。

TMP1075 可在较宽的工作温度范围内实现 $\pm 1^\circ\text{C}$ 的精度，它还具有一个可提供 0.0625°C 温度分辨率的片上 12 位模数转换器 (ADC)。

TMP1075 兼容两线制 SMBus 接口和 I²C 接口，支持高达 32 个器件地址并提供 SMBus 复位和警报功能。

器件信息(1)

器件型号	封装	封装尺寸 (标称值)
TMP1075	VSSOP/DGK (8)	3.00mm × 3.00mm
	SOIC/D (8)	4.90mm × 3.91mm
	WSON/DSG (8)	2.00mm × 2.00mm
	SOT563/DRL (6) ⁽²⁾	1.20mm × 1.60mm

- 如需了解所有可用封装，请参阅数据表末尾的可订购产品附录。
- 可作为 TMP1075N 订购。

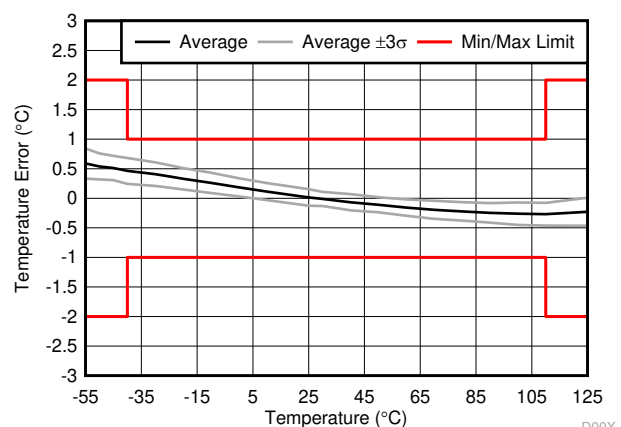

DGK 和 D 封装

温度精度



Table of Contents

1 特性	1	9.2 Functional Block Diagram.....	13
2 应用	1	9.3 Feature Description.....	14
3 说明	1	9.4 Device Functional Modes.....	20
4 Revision History	2	9.5 Register Map.....	22
5 说明 (续)	4	10 Application and Implementation	26
6 Device Comparison	4	10.1 Application Information.....	26
7 Pin Configuration and Functions	5	10.2 Typical Application.....	26
8 Specifications	6	11 Power Supply Recommendations	27
8.1 Absolute Maximum Ratings.....	6	12 Layout	28
8.2 ESD Ratings.....	6	12.1 Layout Guidelines.....	28
8.3 Recommended Operating Conditions.....	6	12.2 Layout Example.....	28
8.4 Thermal Information.....	7	13 Device and Documentation Support	31
8.5 Electrical Characteristics:TMP1075.....	7	13.1 接收文档更新通知.....	31
8.6 Electrical Characteristics: TMP1075N.....	8	13.2 支持资源.....	31
8.7 Timing Requirements:TMP1075.....	9	13.3 Trademarks.....	31
8.8 Timing Requirements: TMP1075N.....	10	13.4 Electrostatic Discharge Caution.....	31
8.9 Switching Characteristics.....	10	13.5 术语表.....	31
8.10 Typical Characteristics.....	11	14 Mechanical, Packaging, and Orderable Information	31
9 Detailed Description	13		
9.1 Overview.....	13		

4 Revision History

注：以前版本的页码可能与当前版本的页码不同

Changes from Revision D (October 2019) to Revision E (August 2021)	Page
• 向列表中添加了 TMP1075N 特性.....	1
• 向特性列表添加了典型精度规格.....	1
• 添加了 SOT563 (TMP1075N 可订购) 封装.....	1
• 在“说明 (续)”部分中添加了 TMP1075N 温度范围.....	4
• Added Device Comparison Section.....	4
• Added figures for different package options.....	5
• Added column for TMP1075N pin numbers.....	5
• Added TMP1075N Specifications.....	6
• Added <i>TMP1075NDRRL Temperature Error vs. Temperature</i> graph.....	11
• Added TMP1075N information in Overview Section.....	13
• Changed the <i>Functional Block Diagram</i> to apply to TMP1075N.....	13
• Added number of I2C addresses available on TMP1075N to Serial Bus Address Section.....	15
• Added table for TMP1075N address options.....	15
• Updated internal register structure figure to apply to TMP1075N.....	15
• Added typical specification for TMP1075N timeout.....	17
• Added clarification on timeout function to include SCL.....	17
• Removed redundant information to accurately describe all packages.....	20
• Added TMP1075N OS bit behavior.....	20
• Added TMP1075N Continuous Conversion Mode information.....	20
• Updated Conversion Rate Diagram to reflect all TMP1075 and TMP1075N.....	20
• Clarified what TM bit behavior for TMP1075 and TMP1075N.....	21
• Added table note to indicate Device ID register is not available on TMP1075N.....	22
• Added TMP1075N configuration register information.....	23
• Updated text to indicate that device ID register does not apply to TMP1075N.....	25
• Added number of I2C addresses available on TMP1075N.....	26
• Changed Typical Connections figure to apply to TMP1075N.....	26

• Removed redundant Application Curve section.....	26
• Updated text to include TMP1075N information.....	26
• Updated Migrating From the xx75 Device Family section to specify TMP1075 compatible packages	26
• Included TMP1075N information to Power Supply Recommendations.....	27
• Added figures to the <i>Layout Example</i> section for each package.....	28

Changes from Revision C (January 2019) to Revision D (October 2019) Page

• 向特性列表中添加了软件兼容性.....	1
• Updated absolute max for Power supply V+ to 6.5V from 6V.....	6
• Updated absolute max for Input voltage on SCL, SDA, A1, A0 to 6.5V from 6V.....	6
• Updated pointer register to be part of the serial interface description.....	15
• Updated the register map table to new format.....	22
• Added access type codes for register bits.....	22
• Updated temperature register format and bit definition table.....	22
• Updated configuration register format and bit definition table	23
• Updated low limit register format and bit definition table	24
• Updated high limit register format and bit definition table	24
• Updated device ID register format and bit definition table	25

Changes from Revision B (December 2018) to Revision C (January 2019) Page

• 将 TMP1075DSG 封装从“预发布”更改为“量产数据”	1
• 将温度精度 (DGK & D) 图表的最小/最大数值由 1.5°C 更改为 1°C.....	1
• Changed min/max limit from 1.5°C to 1°C in the <i>DGK & D Temperature Error vs. Temperature</i> graph.....	11
• Added <i>DSG Temperature Error vs. Temperature</i> graph	11

Changes from Revision A (June 2018) to Revision B (December 2018) Page

• 增加了 TMP1075DSG 封装.....	1
• 更新了数据表的说明部分并添加了 <i>说明 (续)</i> 部分.....	1
• Added TMP1075 configuration register support for single byte read and write.....	23
• Added Software support section for migrating from xx75 to TMP1075	26

Changes from Revision * (March 2018) to Revision A (June 2018) Page

• 将 TMP1075DGK 可订购状态从“预告信息”更改为“量产数据”	1
• 添加了 SOIC 和 DFN 封装.....	1
• Changed the <i>Functional Block Diagram</i>	13
• Changed <i>Digital Temperature Output</i> crossreference from: <i>Temperature Register (0x00)</i> to: <i>Temperature Data Format</i>	14
• Changed the <i>Temperature Data Format</i> table	14
• Changed and renamed the <i>Address Pins and Slave Addresses for the TMP1075</i> table to <i>Address Pins State</i>	15
• Changed the <i>Two-Wire Timing Diagrams</i> section	18
• Added content to the <i>Device Functional Modes</i> section	20

5 说明 (续)

TMP1075 设计用于提供精确且具有成本效益的温度测量，可适用于几乎所有电信、企业、工业和个人电子设备。

TMP1075 D、DGK 和 DSG 封装的额定工作温度范围为 -55°C 至 +125°C，TMP1075N DRL 封装的额定工作温度范围为 -40°C 至 +125°C。

TMP1075 装置在生产调试阶段经过 100% 测试，可通过 NIST 进行追溯，且使用经 ISO/IEC 17025 认证标准校准的设备进行了验证。

6 Device Comparison

表 6-1 lists the key specification and feature differences between the different TMP1075 packages.

表 6-1. Package Feature and Spec Comparison

SPEC/FEATURE	TMP1075			TMP1075N
	D	DGK	DSG	DRL
Supply Voltage	1.7 V to 5.5 V	1.7 V to 5.5 V	1.7 V to 5.5 V	1.62 V to 3.6V
Temperature Range	- 55°C to +125°C	- 55°C to +125°C	- 55°C to +125°C	- 40°C to +125°C
Body Size	4.90 mm × 3.91 mm	3.00 mm × 3.00 mm	2.00 mm × 2.00 mm	1.60 mm × 1.20 mm
Accuracy	±1.0°C: - 40°C to +110°C ±2.0°C: - 55°C to +125°C	±1.0°C: - 40°C to +110°C ±2.0°C: - 55°C to +125°C	±1.0°C : - 40°C to +75°C ±2.0°C: - 55°C to +125°C	±1.0°C: - 10°C to +60°C ±2.0°C: - 40°C to +125°C
I2C Addresses	32	32	32	4
Conversion Rate Settings	Yes	Yes	Yes	No
Device ID	Yes	Yes	Yes	No

7 Pin Configuration and Functions



图 7-1. D Package 8-Pin SOIC Top View



图 7-2. DGK Package 8-Pin VSSOP Top View

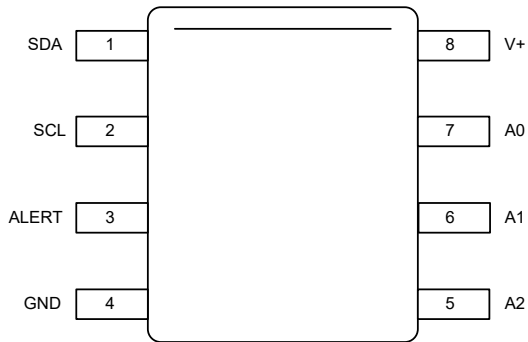

图 7-3. DSG Package 8-Pin WSON Top View

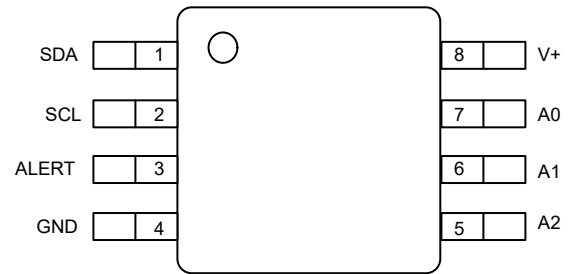

图 7-4. DRL Package 6-Pin SOT563 Top View

1. Pin 1 is determined by orienting the package marking as indicated in the diagram.
2. Referred to as the TMP1075N orderable throughout the document.

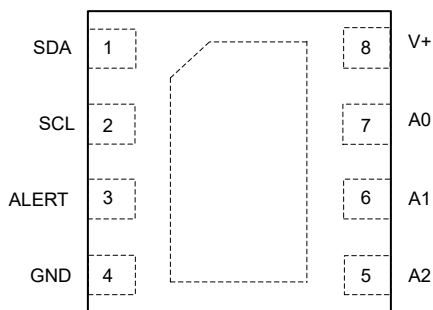
表 7-1. Pin Functions

NAME	PIN		I/O	DESCRIPTION
	SOIC / VSSOP / WSON	SOT563		
A0	7	4	I	Address select A0: Connect to GND, V+, SDA, or SCL
A1	6	—	I	Address select A1: Connect to GND, V+, SDA, or SCL
A2	5	—	I	Address select A2: Connect to GND or V+
ALERT	3	3	O	Overtemperature alert; Open-drain output that requires a pullup resistor
GND	4	2	—	Ground
SCL	2	1	I	Serial clock
SDA	1	6	I/O	Serial data. Open-drain output that requires a pullup resistor
V+	8	5	I	Supply voltage, 1.7 V to 5.5 V (TMP1075); 1.62 V to 3.6 V (TMP1075N)

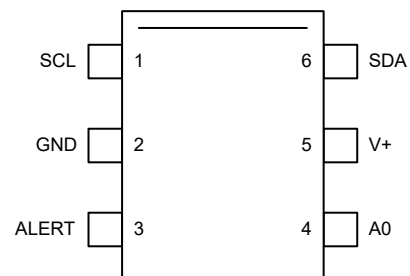
8 Specifications

8.1 Absolute Maximum Ratings

over operating free-air temperature range (unless otherwise noted)⁽¹⁾

		MIN	MAX	UNIT
Power supply, V+	TMP1075		6.5	V
	TMP1075N		4	
Input voltage SCL, SDA, A1, A0	TMP1075	- 0.3	6.5	V
Input voltage SCL, SDA, A0	TMP1075N	- 0.3	4	V
Input voltage ALERT	TMP1075N		(V+)+0.3 and ≤4	V
Input voltage A2 pin	TMP1075	- 0.3	(V+) + 0.3	V
Operating temperature		- 55	150	°C
Junction temperature, T _J			150	°C
Storage temperature, T _{stg}		- 60	130	°C

- (1) Stresses beyond those listed under *Absolute Maximum Ratings* may cause permanent damage to the device. These are stress ratings only, which do not imply functional operation of the device at these or any other conditions beyond those indicated under *Recommended Operating Conditions*. Exposure to absolute-maximum-rated conditions for extended periods may affect device reliability.

8.2 ESD Ratings

			VALUE	UNIT
V _(ESD)	Electrostatic discharge	Human body model (HBM), per ANSI/ESDA/JEDEC JS-001 ⁽¹⁾	2000	V
		Charged device model (CDM), per JEDEC specification JESD22-C101 ⁽²⁾	1000	

- (1) JEDEC document JEP155 states that 500-V HBM allows safe manufacturing with a standard ESD control process.
 (2) JEDEC document JEP157 states that 250-V CDM allows safe manufacturing with a standard ESD control process.

8.3 Recommended Operating Conditions

over operating free-air temperature range (unless otherwise noted)

		MIN	NOM	MAX	UNIT
Supply voltage	TMP1075	1.7		5.5	V
	TMP1075N	1.62	3.3	3.6	V
Operating free-air temperature, T _A	TMP1075	- 55		125	°C
	TMP1075N	-40		125	°C

8.4 Thermal Information

THERMAL METRIC ⁽¹⁾		TMP1075	TMP1075	TMP1075	TMP1075N	UNIT
		DGK (VSSOP)	D (SOIC)	DSG (WSON)	DRL (SOT)	
		8 PINS	8 PINS	8 PINS	6 PINS	
R _{θJA}	Junction-to-ambient thermal resistance	202.5	130.4	87.4	210.3	°C/W
R _{θJC(top)}	Junction-to-case (top) thermal resistance	82	76.9	111.1	105.0	°C/W
R _{θJB}	Junction-to-board thermal resistance	124.4	72.3	54	87.5	°C/W
Ψ _{JT}	Junction-to-top characterization parameter	17.9	32	9.8	6.1	°C/W
Ψ _{JB}	Junction-to-board characterization parameter	122.6	71.9	54.4	87.0	°C/W
R _{θJC(bot)}	Junction-to-case (bottom) thermal resistance	—	—	28.1	—	°C/W
M _T	Thermal mass	16.6	64.2	5.0	—	mJ/°C

(1) For more information about traditional and new thermal metrics, see the [Semiconductor and IC Package Thermal Metrics](#) application report.

8.5 Electrical Characteristics:TMP1075

at T_A = -55°C to +125°C and V₊ = 1.7 V to 5.5 V (unless noted); typical specification are at T_A = 25°C and V₊ = 3.3 V

PARAMETER		TEST CONDITIONS	MIN	TYP	MAX	UNIT
TEMPERATURE INPUT						
	Range		-55		125	°C
Accuracy (temperature error)	DGK, D	-40°C to +110°C		±0.25	±1	°C
		-55°C to +125°C		±0.25	±2	
	DSG	-40°C to +75°C		±0.25	±1	°C
		-55°C to +125°C		±0.25	±2	°C
Accuracy (temperature error) vs. supply	PSRR				±0.03	°C/V
Resolution	1 LSB (12 bit)			0.0625		°C
Repeatability ⁽¹⁾	25°C, V ₊ = 3.3 V ⁽²⁾			0.0625		°C
Long-term drift ⁽³⁾	500 hours at 150°C, 5.5V			0.0625		°C
DIGITAL INPUT/OUTPUT						
	Input capacitance			5		pF
V _{IH}	High-level input logic		0.7(V ₊)			V
V _{IL}	Low-level input logic			0.3(V ₊)		V
I _{IN}	Leakage input current		-0.25	0	0.25	μA
	Input voltage hysteresis	SCL and SDA pins		600		mV
V _{OL}	Low-level output logic	I _{OL} = -3 mA, SDA and ALERT pins	0	0.15	0.4	V
	ADC Conversion time	one-shot mode	4.5	5.5	7	ms
T _C	Conversion Time	R1 = 0, R0 = 0 (default)		27.5		ms
		R1 = 0, R0 = 1		55		
		R1 = 1, R0 = 0		110		
		R1 = 1, R0 = 1		220		
	Reset time	The time between reset till ADC conversion start		0.3		ms
	Conversion Rate Variation		-10	0	10	%
POWER SUPPLY						
	Operating voltage range		1.7	3.3	5.5	V

at $T_A = -55^\circ\text{C}$ to $+125^\circ\text{C}$ and $V+ = 1.7\text{ V}$ to 5.5 V (unless noted); typical specification are at $T_A = 25^\circ\text{C}$ and $V+ = 3.3\text{ V}$

PARAMETER		TEST CONDITIONS	MIN	TYP	MAX	UNIT
I_Q	Quiescent current (serial bus inactive)	R1 = 0, R0 = 0 (default)		10	20	μA
		R1 = 0, R0 = 1		5.5	9	
		R1 = 1, R0 = 0		4	6	μA
		R1 = 1, R0 = 1		2.7	4	
		During 5.5 ms active conversion		52	85	μA
I_{SD}	Shutdown current	Serial bus active, SCL frequency = 400 kHz, A0=A1=A2=GND		13		μA
		Serial bus inactive, A0=A1=A2=SCL=SDA=V+, 25°C		0.37	0.65	μA
		Serial bus inactive, A0=A1=A2=SCL=SDA=V+		0.37	3.5	μA
	Power supply thresholds	Supply rising, Power-on Reset		1.22		V
		Supply failing, Brown-out Detect		1.1		

- Repeatability is the ability to reproduce a reading when the measured temperature is applied consecutively, under the same conditions.
- One-shot mode setup, 1 sample per minute for 24 hours.
- Long-term drift is determined using accelerated operational life testing at a junction temperature of 150°C .

8.6 Electrical Characteristics: TMP1075N

At $T_A = 25^\circ\text{C}$ and $V+ = 1.62$ to 3.6 V (unless otherwise noted)

PARAMETER		TEST CONDITIONS	MIN	TYP	MAX	UNIT
TEMPERATURE SENSOR						
	Temperature Operating Range		-40		125	$^\circ\text{C}$
T_{ERR}	Temperature accuracy	-10°C to 60°C		0.25	± 1	$^\circ\text{C}$
		-40°C to 125°C		0.5	± 2	
PSR	DC power supply rejection			0.2	0.5	$^\circ\text{C}/\text{V}$
T_{RES}	Temperature resolution	Including sign bit		12		Bits
		LSB		62.5		m°C
t_{CONV}	Conversion time			26	35	ms
DIGITAL INPUT/OUTPUT						
C_{IN}	Input capacitance			3		pF
V_{IH}	Input logic high level		$0.7 \times V+$		3.6	V
V_{IL}	Input logic low level				$0.3 \times V+$	V
I_{IN}	Input leakage current	$0\text{ V} < V+ < 3.6\text{ V}$			1	μA
V_{OL}	Output low level	SDA, ALERT ($V+ > 2\text{ V}$, $I_{OL} = 3\text{ mA}$)	0		0.4	V
V_{OL}	Output low level	SDA, ALERT ($V+ < 2\text{ V}$, $I_{OL} = 3\text{ mA}$)	0		$0.2 \times V+$	V
POWER SUPPLY						
$V+$	Operating supply range		1.62		3.6	V
I_{DD_AVG}	Average current consumption	Serial bus inactive		7	10	μA
		Serial bus active, SCL frequency = 400 kHz		15		
		Serial bus active, SCL frequency = 2.85 MHz		85		
I_{DD_SD}	Shutdown current	Serial bus inactive		0.5	1	μA
		Serial bus active, SCL frequency = 400 kHz		10		μA
		Serial bus active, SCL frequency = 2.85 MHz		80		μA

8.7 Timing Requirements:TMP1075

minimum and maximum specifications are over - 55°C to 125°C and V+ = 1.7 V to 5.5 V (unless otherwise noted)⁽¹⁾

		FAST MODE		HIGH-SPEED MODE		UNIT
		MIN	MAX	MIN	MAX	
f _(SCL)	SCL operating frequency	0.001	0.4	0.001	2.56	MHz
t _(BUF)	Bus-free time between STOP and START conditions	1300		160		ns
t _(HDSTA)	Hold time after repeated START condition. After this period, the first clock is generated.	600		160		ns
t _(SUSTA)	Repeated START condition setup time	600		160		ns
t _(SUSTO)	STOP condition setup time	600		160		ns
t _(HDDAT)	Data hold time ⁽²⁾	0		0	130	ns
t _(SUDAT)	Data setup time	100		20		ns
t _(LOW)	SCL clock low period	1300		250		ns
t _(HIGH)	SCL clock high period	600		60		ns
t _(VDAT)	Data valid time (data response time) ⁽³⁾		900		130	ns
t _(FDA)	Data fall time		300		100	ns
t _(R)	Clock rise time		300		40	ns
t _(F)	Clock fall time		300		40	ns
t _(timeout)	Timeout (SCL = SDA = GND)	20	30	20	30	ms
t _(RC)	Clock/ data rise time for SCL = 100 kHz		1000			ns

(1) The host and device have the same V+ value. Values are based on statistical analysis of samples tested during initial release.

(2) The maximum t_(HDDAT) can be 0.9 μs for fast mode, and is less than the maximum t_(VDAT) by a transition time.

(3) t_(VDAT) = time for data signal from SCL LOW to SDA output (HIGH to LOW, depending on which is worse). = time for data signal from SCL LOW to SDA output (HIGH to LOW, depending on which is worse).

8.8 Timing Requirements: TMP1075N

minimum and maximum specifications are over - 40°C to 125°C and V+ = 1.62 V to 3.6 V (unless otherwise noted)⁽¹⁾

		FAST MODE		HIGH-SPEED MODE		UNIT
		MIN	MAX	MIN	MAX	
f _(SCL)	SCL operating frequency	0.001	0.4	0.001	2.85	MHz
t _(BUF)	Bus-free time between STOP and START conditions	600		160		ns
t _(HDSTA)	Hold time after repeated START condition. After this period, the first clock is generated.	600		160		ns
t _(SUSTA)	Repeated START condition setup time	600		160		ns
t _(SUSTO)	STOP condition setup time	600		160		ns
t _(HDDAT)	Data hold time ⁽²⁾	100	900	25	105	ns
t _(SUDAT)	Data setup time	100		25		ns
t _(LOW)	SCL clock low period	1300		210		ns
t _(HIGH)	SCL clock high period	600		60		ns
t _{FD}	Data fall time		300		80	ns
t _{RD}	Data rise time		300			
		SCLK ≤ 100 kHz	1000			
t _{RC}	Clock rise time		300		40	ns
t _{FC}	Clock fall time		300		40	ns
t _{timeout}	Timeout (SCL = SDA = GND)	30	40	30	40	ms

(1) The host and device have the same V+ value. Values are based on statistical analysis of samples tested during initial release.

(2) The maximum t_(HDDAT) can be 0.9 μs for fast mode, and is less than the maximum t_(VDAT) by a transition time.

8.9 Switching Characteristics

over operating free-air temperature range (unless otherwise noted)

			MIN	TYP	MAX	UNIT
t _{LPF}	Spike filter for I ³ C compatibility	SCL= 12.5 MHz		50		ns

8.10 Typical Characteristics

at $T_A = 25^\circ\text{C}$, $V_+ = 3.3\text{ V}$, and apply to D, DGK, and DSG packages (unless otherwise noted)



图 8-1. DGK & D Temperature Error vs. Temperature



图 8-2. DSG Temperature Error vs. Temperature

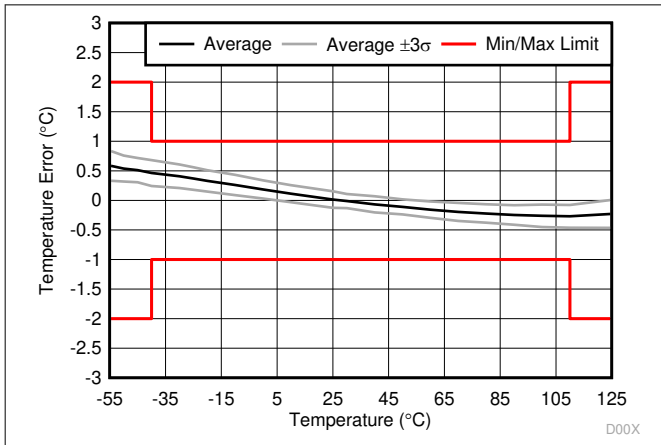

图 8-3. TMP1075NDRL Temperature Error vs. Temperature

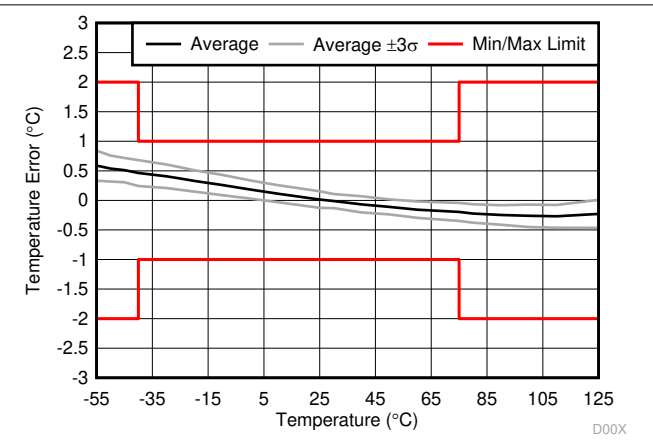

图 8-4. Shutdown Current vs. Temperature

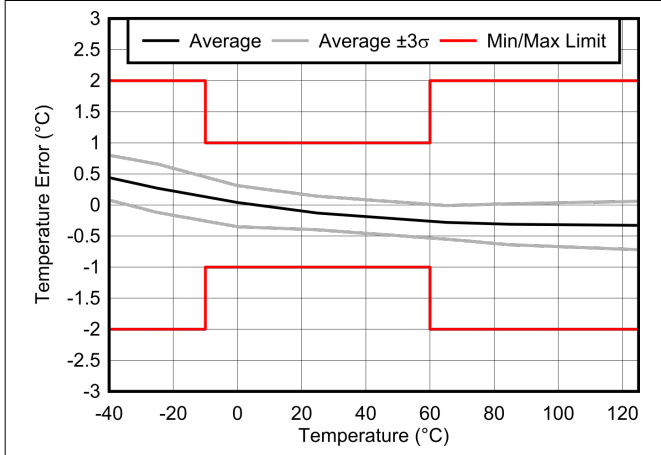

图 8-5. Average Current vs. Conversion Rates and Temperature

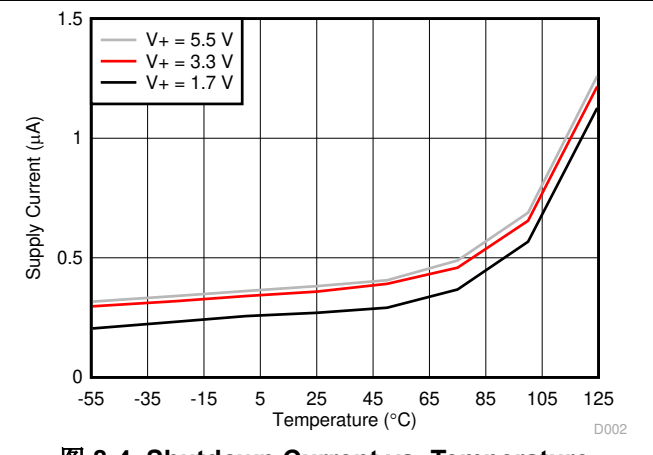

图 8-6. Supply Current vs. Input Cell Voltage

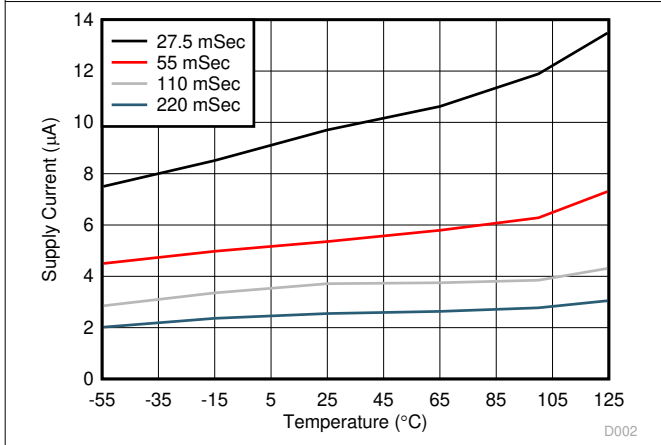

图 8-7. Supply Current vs. I²C Bus Clock and Supply Voltage in Shutdown Mode

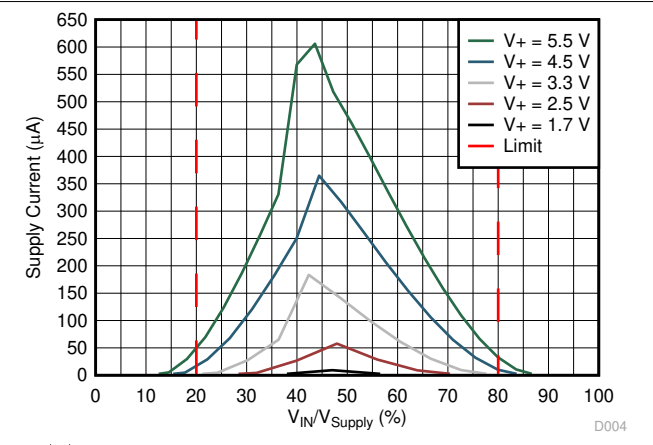

图 8-8. ALERT Pin Output Voltage vs. Sink Current

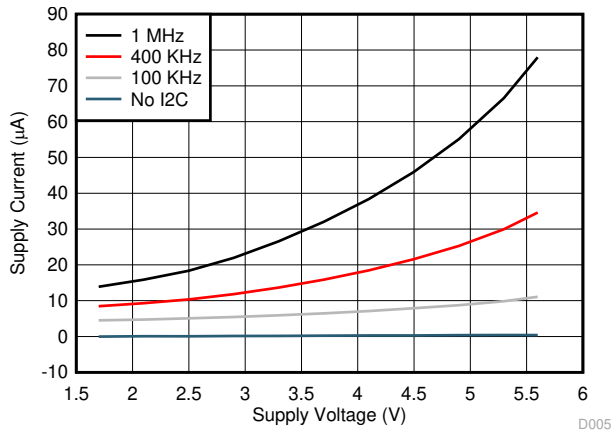

图 8-9. Sampling Period Change vs. Temperature (1.7 V to 5.5 V)

9 Detailed Description

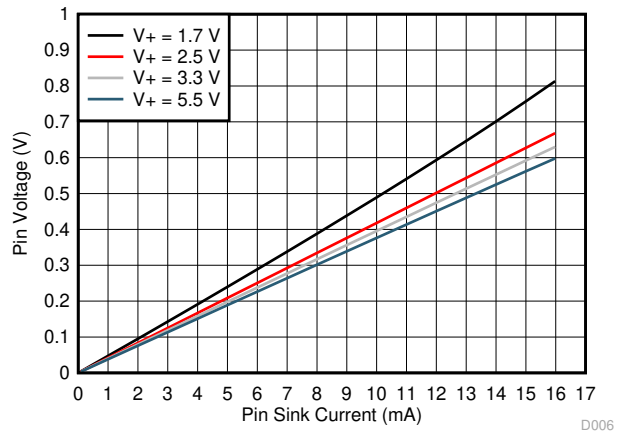
9.1 Overview

The TMP1075 device is a digital temperature sensor that is optimal for thermal management and thermal protection applications. The TMP1075 is a SMBus and is I²C interface-compatible. It is also capable of coexisting in an I³C bus when in Mixed Fast Mode. The TMP1075 non-N orderables are specified over a temperature range of -55°C to +125°C and the TMP1075N orderable is specified over the -40°C to +125°C temperature range. The [Figure 9-1](#) section shows an internal block diagram of TMP1075 device.

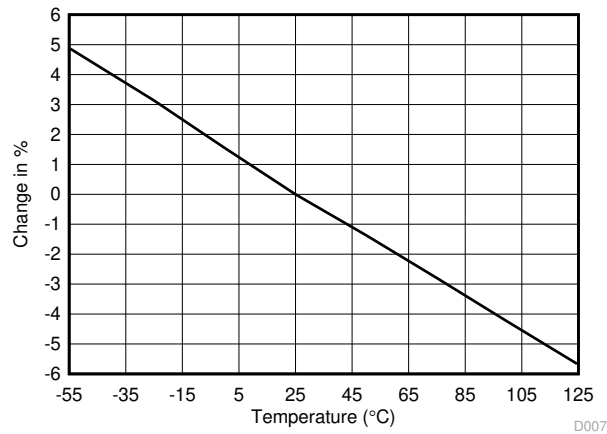
The temperature sensor thermal path runs through the package leads as well as the plastic package. The leads provide the primary thermal path due to the lower thermal resistance of the metal.

9.2 Functional Block Diagram

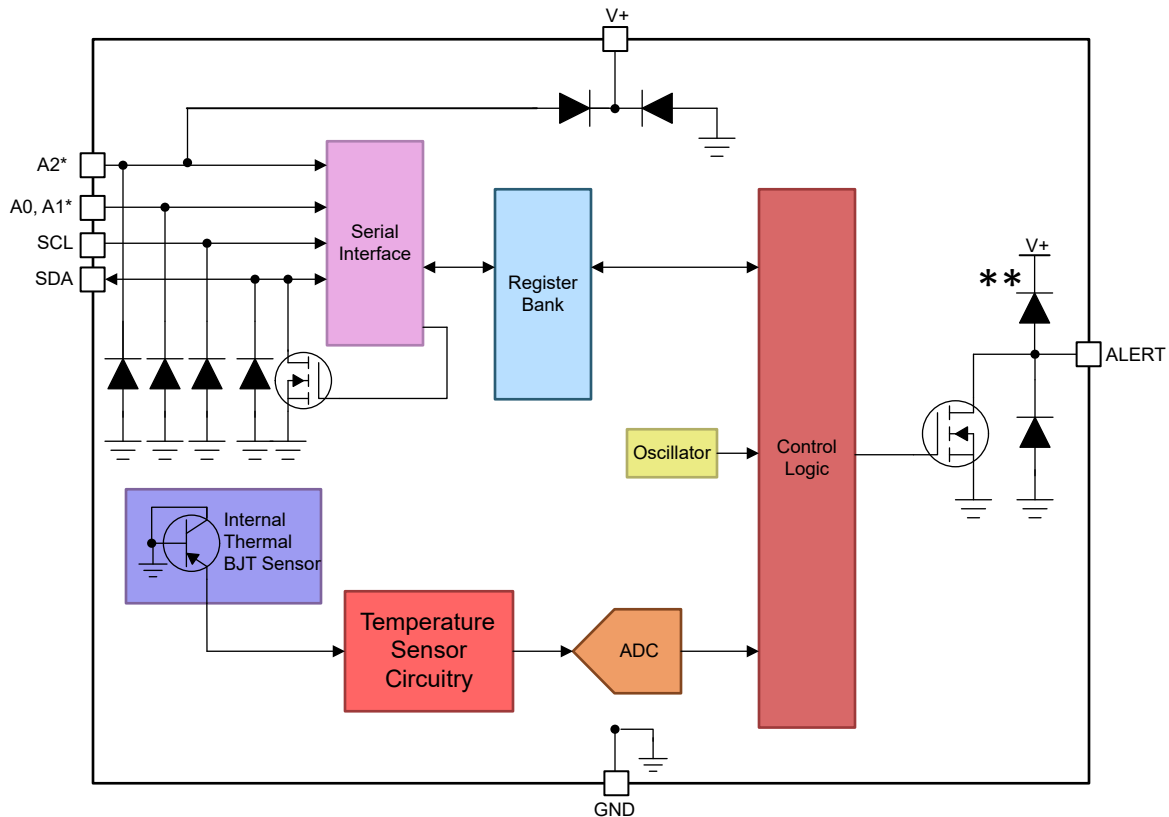

*Pin is not available on TMP1075N

** ESD Diode only in TMP1075N

图 9-1. Functional Block Diagram

9.3 Feature Description

9.3.1 Digital Temperature Output

The digital output from each temperature measurement conversion is stored in the read-only temperature register. Which is a 12-bit, read-only register that stores the output of the most recent conversion. Two bytes must be read to obtain data. However, only the first 12 MSBs are used to indicate temperature while the remaining 4 LSB are set to zero. 表 9-1 lists the data format for the temperature. Negative numbers are represented in binary two's-complement format. After power-up or reset, the temperature register reads 0°C until the first conversion is complete.

表 9-1. Temperature Data Format

TEMPERATURE (°C)	DIGITAL OUTPUT	
	BINARY	HEX
127.9375	0111 1111 1111 0000	7FF0
100	0110 0100 0000 0000	6400
80	0101 0000 0000 0000	5000
75	0100 1011 0000 0000	4B00
50	0011 0010 0000 0000	3200
25	0001 1001 0000 0000	1900
0.25	0000 0000 0100 0000	0040
0.0625	0000 0000 0001 0000	0010
0	0000 0000 0000 0000	0000
- 0.0625	1111 1111 1111 0000	FFF0
- 0.25	1111 1111 1100 0000	FFC0
- 25	1110 0111 0000 0000	E700
- 50	1100 1110 0000 0000	CE00
- 128	1000 000 0000 0000	8000

9.3.2 I²C and SMBus Serial Interface

The TMP1075 operates as a target device on the two-wire, SMBus and I²C interface-compatible bus. Connections to the bus are made through the open-drain I/O line SDA and SCL input pin. The SDA and SCL pins feature integrated spike suppression filters and Schmitt triggers to minimize the effects of input spikes and bus noise. The TMP1075 supports the transmission protocol for fast mode up to 400 kHz and high-speed mode up to 2.56 MHz. All data bytes are transmitted MSB first.

9.3.2.1 Bus Overview

The device that initiates the data transfer is called a host, and the devices controlled by the host are the target. The bus must be controlled by a host device that generates the SCL that controls the bus access and generates the START and STOP conditions.

To address a specific device, a START condition is initiated. This is indicated by the host pulling the data line SDA from a high to low logic level when SCL is high. All target devices on the bus shift in the device address byte on the rising edge of the clock with the last bit indicating whether a read or write operation is intended. During the ninth clock pulse, the device being addressed responds to the host by generating an Acknowledge and pulling SDA low.

Data transfer is then initiated and sent over eight clock pulses followed by an Acknowledge bit. During data transfer, SDA must remain stable when SCL is high because any change in SDA when SCL is high is interpreted as a control signal.

When all data are transferred, the host generates a STOP condition indicated by pulling SDA from low to high logic level when SCL is high.

9.3.2.2 Serial Bus Address

To communicate with the TMP1075, the host must first address devices through an address byte. The device address byte consists of seven address bits and a direction bit indicating the intent of executing a read or write operation.

The TMP1075 features three address pins to allow up to 32 devices (TMP1075N: 4) to be addressed on a single bus interface. 表 9-2 and 表 9-3 describe the pin logic levels used to configure the TMP1075 I2C address. The state of pins A0, A1, and A2 is sampled on every bus communication and must be set prior to any activity on the interface.

表 9-2. TMP1075 Address Pins State

A2	A1	A0	7-BIT ADDRESS	A2	A1	A0	7-BIT ADDRESS
0	0	SDA	1000000	0	SDA	SDA	1010000
0	0	SCL	1000001	0	SDA	SCL	1010001
0	1	SDA	1000010	0	SCL	SDA	1010010
0	1	SCL	1000011	0	SCL	SCL	1010011
1	0	SDA	1000100	1	SDA	SDA	1010100
1	0	SCL	1000101	1	SDA	SCL	1010101
1	1	SDA	1000110	1	SCL	SDA	1010110
1	1	SCL	1000111	1	SCL	SCL	1010111
0	0	0	1001000	0	SDA	0	1011000
0	0	1	1001001	0	SDA	1	1011001
0	1	0	1001010	0	SCL	0	1011010
0	1	1	1001011	0	SCL	1	1011011
1	0	0	1001100	1	SDA	0	1011100
1	0	1	1001101	1	SDA	1	1011101
1	1	0	1001110	1	SCL	0	1011110
1	1	1	1001111	1	SCL	1	1011111

表 9-3. TMP1075N Address Pins State

A0	7-BIT ADDRESS
0	1001000
1	1001001
SDA	1001010
SCL	1001011

9.3.2.3 Pointer Register

图 9-2 shows the internal register structure of the TMP1075, and 表 9-5 lists the pointer addresses of the register map. 表 9-4 shows that the register map reset value of the pointer register is 00h.



图 9-2. Internal Register Structure

9.3.2.3.1 Pointer Register Byte [reset = 00h]

表 9-4. Pointer Register Byte

P7	P6	P5	P4	P3	P2	P1	P0
0	0	0	0	Register Bits			

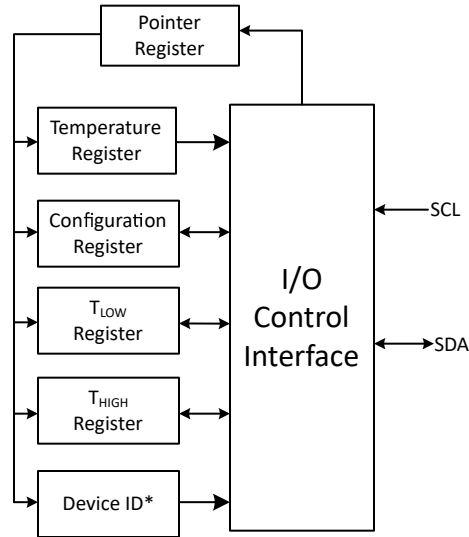
9.3.2.4 Writing and Reading to the TMP1075

Accessing a particular register on the TMP1075 device is accomplished by writing the appropriate value to the pointer register. After Reset, the register value is set to zero. The value for the pointer register is the first byte transferred after the device address byte with the R/W bit low. Every write operation to the TMP1075 requires a value for the pointer register (see 图 9-3).

When reading from the TMP1075 device, the last value stored in the pointer register by a write operation is used to determine which register is read by a read operation. To change the register pointer for a read operation, a new value must be written to the pointer register. This action is accomplished by issuing a device address byte with the R/ \bar{W} bit low, followed by the pointer register byte. No additional data are required. The host can then generate a START condition and send the device address byte with the R/ \bar{W} bit high to initiate the read command. See 图 9-5 for details of this sequence. If repeated reads from the same register are desired, the pointer register bytes do not have to be continually sent because the TMP1075 remembers the pointer register value until the value is changed by the next write operation.

Register bytes are sent MSB first.

9.3.2.5 Operation Mode

The TMP1075 can operate as a receiver or transmitter. As a target device, the TMP1075 never drives the SCL line.

9.3.2.5.1 Receiver Mode

The first byte transmitted by the host is the device address with the R/ \bar{W} bit low. The TMP1075 then acknowledges reception of a valid address. The next byte transmitted by the host is the pointer register. The TMP1075 then acknowledges reception of the pointer register byte. The next byte or bytes are written to the register addressed by the pointer register. The TMP1075 acknowledges reception of each data byte. The host can terminate data transfer by generating a START or STOP condition.

9.3.2.5.2 Transmitter Mode

The first byte is transmitted by the host and is the device address, with the R/\bar{W} bit high. The target device acknowledges reception of a valid device address. The next byte is transmitted by the device and is the most significant byte of the register indicated by the Pointer register. The host acknowledges reception of the data byte. The next byte transmitted by the device is the least significant byte. The host acknowledges reception of the data byte. The host can terminate data transfer by generating a Not-Acknowledge on reception of any data byte, or generating a START or STOP condition.

9.3.2.6 SMBus Alert Function

The TMP1075 supports the SMBus Alert function. When the TMP1075 is operating in interrupt mode ($TM = 1$), the ALERT pin of the TMP1075 can be connected as an SMBus Alert signal. When a host senses that an alert condition is present on the ALERT line, the host sends an SMBus Alert command (00011001) on the bus. If the ALERT pin of the TMP1075 is active, the devices acknowledge the SMBus Alert command and respond by returning the device address on the SDA line. The eighth bit (LSB) of the device address byte indicates if the temperature exceeding T_{HIGH} or falling below T_{LOW} caused the alert condition. This bit is equal to POL if the temperature is greater than or equal to T_{HIGH} . This bit is equal to \bar{POL} if the temperature is less than T_{LOW} . See [图 9-8](#) for details of this sequence.

If multiple devices on the bus respond to the SMBus Alert command, arbitration during the device address portion of the SMBus Alert command determines which device clears the alert status. If the TMP1075 wins the arbitration, the ALERT pin becomes inactive at the completion of the SMBus Alert command. If the TMP1075 loses the arbitration, the ALERT pin remains active.

9.3.2.7 General Call- Reset Function

The TMP1075 responds to the two-wire general call address (0000 000) if the eighth bit is 0. The device acknowledges the general call address and responds to commands in the second byte. If the second byte is 00000 110, the TMP1075 resets the internal registers to the power-up reset values.

9.3.2.8 High-Speed Mode (HS)

For the two-wire bus to operate at frequencies above 400 kHz, the host device must issue an HS mode host code (00001XXX) as the first byte after a START condition to switch the bus to high-speed operation. The TMP1075 device does not acknowledge this byte, but it does switch the input filters on the SDA and SCL and the output filters on the SDA to operate in HS mode. After the HS mode host code is issued, the host transmits a two-wire device address to initiate a data transfer operation. The bus continues to operate in HS mode until a STOP condition occurs on the bus. Upon receiving the STOP condition, the TMP1075 switches the input and output filters back to fast-mode operation.

9.3.2.9 Coexists in I³C Mixed Fast Mode

A bus with both I³C and I²C interfaces is referred to as a mixed fast mode with clock speeds up to 12.5 MHz. In order for the TMP1075, which is an I²C device, to coexist in the same bus, the device incorporated a spike suppression filter of 50 ns on the SDA and SCL pins to avoid any interference to the bus when communicating with I³C devices.

9.3.2.10 Time-Out Function

The TMP1075 resets the serial interface if SCL is held low by the host or SDA is held low by the TMP1075 for 25 ms (TMP1075N: 30 ms) (typical) between a START and STOP condition. The TMP1075 releases the SDA bus and waits for a START condition. To avoid activating the time-out function, a communication speed of at least 1 kHz must be maintained.

9.3.3 Timing Diagrams

The TMP1075 is two-wire SMBus and I²C interface-compatible. [图 9-3](#) to [图 9-8](#) describe the various operations on the TMP1075. The following list provides bus definitions.

Bus Idle: Both SDA and SCL lines remain high.

Start Data Transfer: A change in the state of the SDA line from high to low when the SCL line is high defines a START condition. Each data transfer is initiated with a START condition.

Stop Data Transfer: A change in the state of the SDA line from low to high when the SCL line is high defines a STOP condition. Each data transfer is terminated with a repeated START or STOP condition.

Data Transfer: The number of data bytes transferred between a START and a STOP condition is not limited and is determined by the host device. The receiver acknowledges the transfer of data.

Acknowledge: Each receiving device, when addressed, is obliged to generate an Acknowledge bit. A device that acknowledges must pull down the SDA line during the Acknowledge clock pulse in such a way that the SDA line is stable low during the high period of the Acknowledge clock pulse. Setup and hold times must be taken into account. On a host receive, the termination of the data transfer can be signaled by the host generating a Not-Acknowledge on the last byte that is transmitted by the target device.

9.3.4 Two-Wire Timing Diagrams



图 9-3. Two-Wire Timing Diagram for Write Word Format



图 9-4. Two-Wire Timing Diagram for Write Single Byte Format

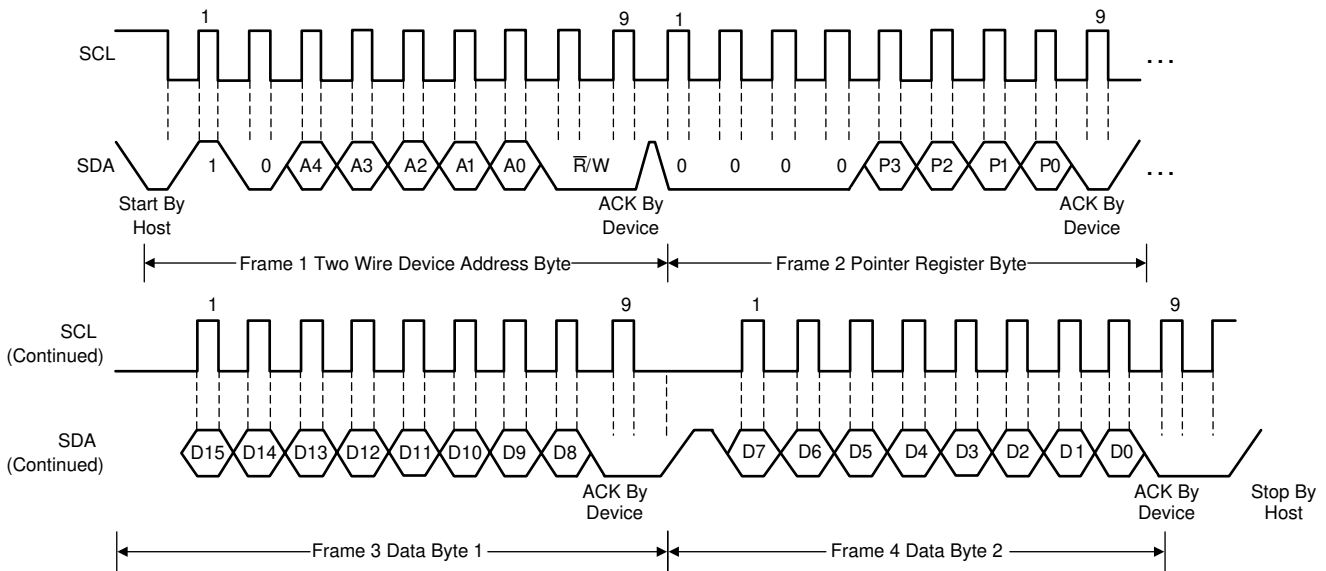

图 9-5. Two-Wire Timing Diagram for Read Word Format

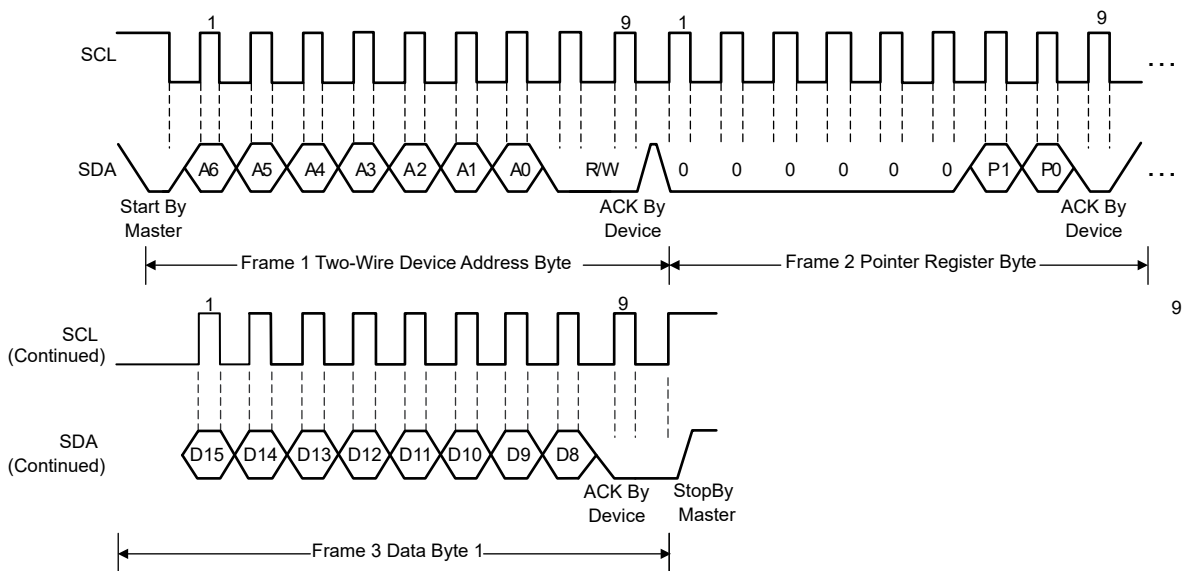

Copyright © 2017, Texas Instruments Incorporated

图 9-6. Two-Wire Timing Diagram for Read Single Byte Format

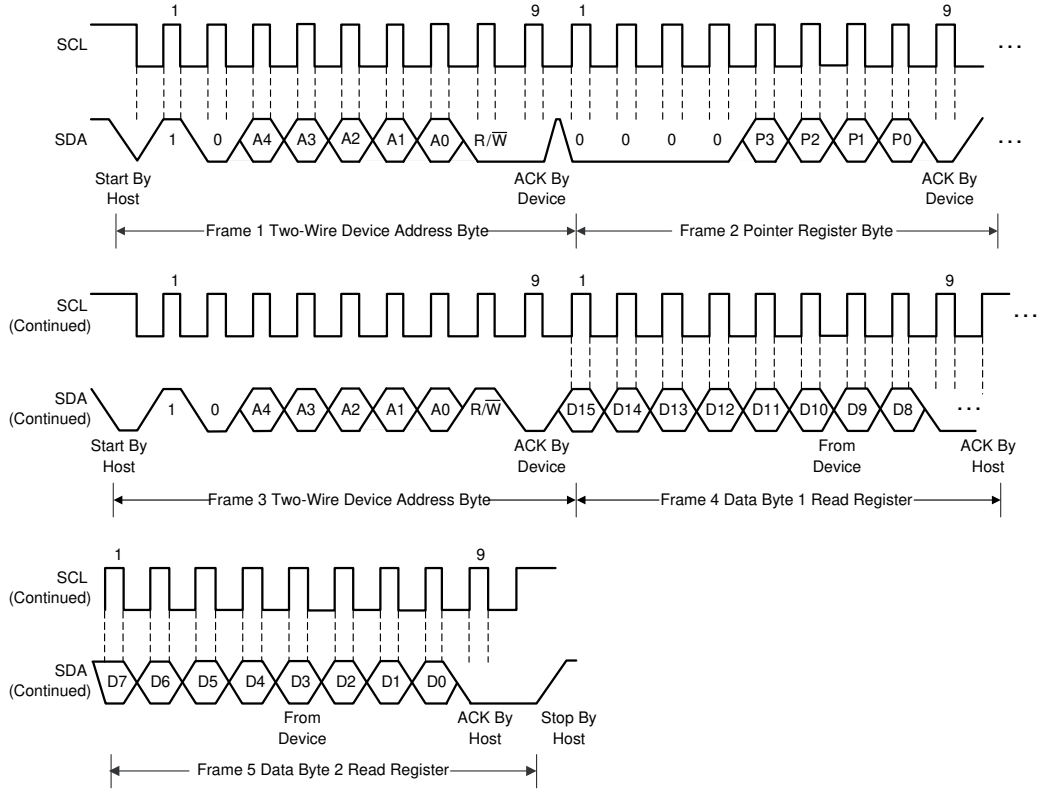
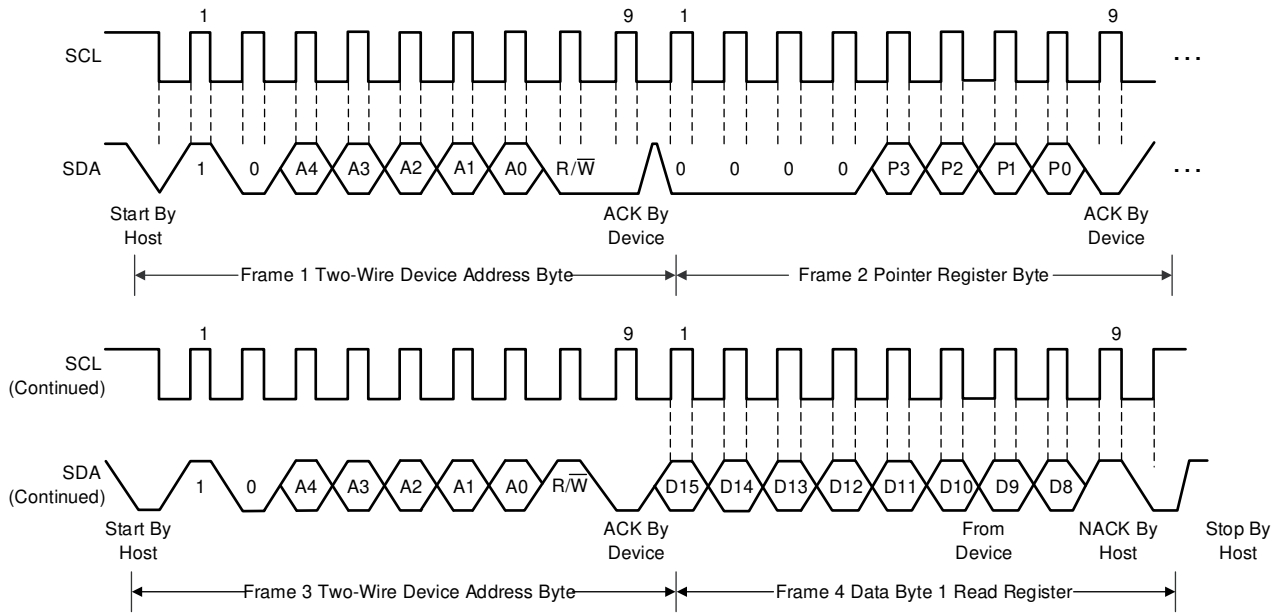

图 9-7. General-Call Reset Command Timing Diagram



图 9-8. Timing Diagram for SMBus Alert

9.4 Device Functional Modes

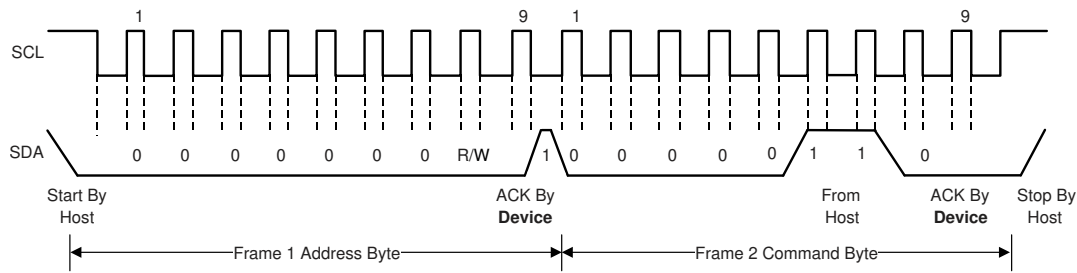
9.4.1 Shutdown Mode (SD)

Shutdown mode (SD) of the TMP1075 device allows the user to conserve power by shutting down all device circuitry except the serial interface, which significantly reduces the current consumption. SD is initiated when the SD bit in the configuration register is set to 1. When SD is equal to 0, the device stays in continuous conversion mode.

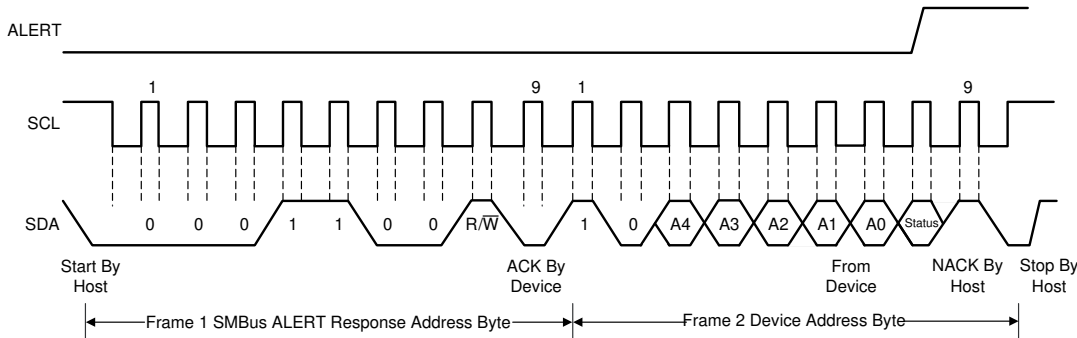
9.4.2 One-Shot Mode (OS)

The TMP1075 features a one-shot mode (OS) temperature measurement. When the device is in shutdown mode, writing 1 to the OS bit starts a single temperature conversion. The device returns to the shutdown state at the completion of the single conversion. This feature is useful to reduce power consumption in the TMP1075 when continuous temperature monitoring is not required.

When the configuration register is read, the OS bit always reads 0 on TMP1075 non-N orderables. On the TMP1075N orderable, the OS bit reads back 0 during the one-shot conversion and 1 after the conversion cycle.

9.4.3 Continuous Conversion Mode (CC)

When the device is operating in continuous conversion mode (SD=0), every conversion cycle consists of an active conversion, followed by a standby (see 图 9-9). The device consumes a higher current during an active conversion, and lower current during standby. Active conversion time is 5.5 ms (TMP1075N: 23 ms) before the part goes in standby. 表 9-8 shows the list of conversion cycle configured using [R1:R0] bits in the configuration register.



图 9-9. Conversion Rate Diagram

9.4.4 Thermostat Mode (TM)

The thermostat mode bit indicates whether ALERT pin operates in comparator mode (TM = 0) or interrupt mode (TM = 1). ALERT pin mode is controlled by TM (bit 9) of the configuration register. Any write to the TM bit changes the ALERT pin to a none active condition, clears the faults count, and clears the alert interrupt history on the TMP1075 non-N orderables. The ALERT pin can be disabled in both comparator and interrupt modes if both limit registers are set to the rail values $T_{LOW} = -128^{\circ}\text{C}$ and $T_{HIGH} = +127.9375^{\circ}\text{C}$ on the TMP1075 non-N orderables.

9.4.4.1 Comparator Mode (TM = 0)

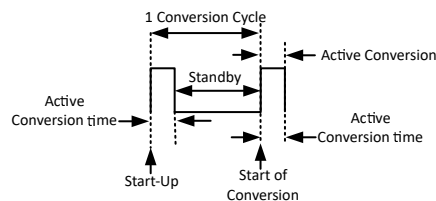
In comparator mode (TM = 0), the ALERT pin becomes active when the temperature equals or exceeds the value in T_{HIGH} for a consecutive number of Fault Queue bits [F1:F0]. The ALERT pin remains active until the temperature falls below the indicated T_{LOW} value for the same number of faults.

The difference between the two limits acts as a hysteresis on the comparator output, and a fault counter prevents false alerts as a result of system noise. The SMBus Alert response function is ignored in the comparator mode.

9.4.4.2 Interrupt Mode (TM = 1)

In interrupt mode (TM = 1), the device starts to compare temperature readings with the high limit register value. The ALERT pin becomes active when the temperature equals or exceeds T_{HIGH} for a consecutive number of conversions as set by the Fault Queue bits [F1:F0]. The ALERT pin remains active until it is cleared by one of three events: a read of any register, a successful SMBus Alert response, or a shutdown command. After the ALERT pin is cleared, the device starts to compare temperature readings with the T_{LOW} . The ALERT pin becomes active again only when the temperature drops below T_{LOW} for a consecutive number of conversions as set by the Fault Queue bits. The ALERT pin remains active until cleared by any of the same three clearing events. After the ALERT pin is cleared by one of the events, the cycle repeats and the device resumes to compare the temperature to T_{HIGH} . The interrupt mode history is cleared by a change in the TM=0 bit, setting the device to SD mode, or resetting the device on the TMP1075 non-N orderables.

9.4.4.3 Polarity Mode (POL)

The polarity bit allows the user to adjust the polarity of the ALERT pin output. If the POL bit is set to 0 (default), the ALERT pin becomes active low. When POL bit is set to 1, the ALERT pin becomes active high and the state of the ALERT pin is inverted. 图 9-10 shows the operation of the ALERT pin in various modes.



图 9-10. Output Transfer Function Diagrams

9.5 Register Map

表 9-5. TMP1075 Register Map

ADDRESS	TYPE	RESET	ACRONYM	REGISTER NAME	SECTION
00h	R	0000h	TEMP	Temperature result register	Go
01h	R/W	00FFh	CFGR	Configuration register	Go
02h	R/W	4B00h	LLIM	Low limit register	Go
03h	R/W	5000h	HLIM	High limit register	Go
0Fh ⁽¹⁾	R	7500h	DIEID	Device ID register	Go

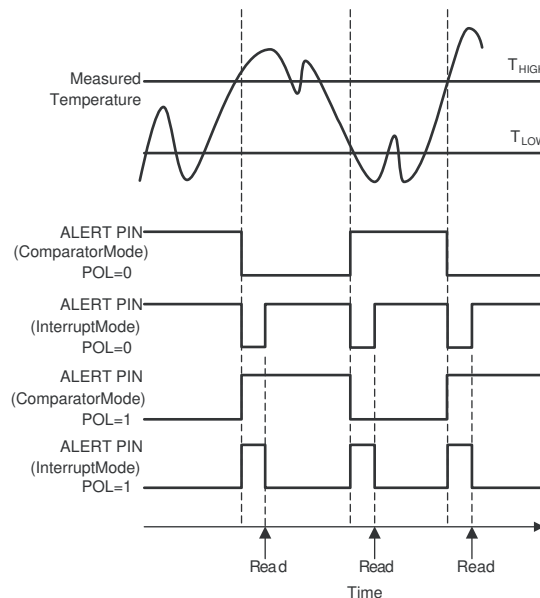
(1) Device ID register not available on TMP1075N

Note

TMP1075 Configuration register supports single byte read and write for software compatibility with xx75 standard temperature sensors.

9.5.1 Register Descriptions

表 9-6. TMP1075 Access Type Codes

Access Type	Code	Description
Read Type		
R	R	Read
Write Type		
W	W	Write
Reset or Default Value		
-n		Value after reset or the default value

9.5.1.1 Temperature Register (address = 00h) [default reset = 0000h]

The temperature register of the TMP1075 is a 12-bit, read-only register that stores the result of the most recent conversion (see 图 9-11). Data is represented in binary two's complement format. The first 12 bits are used to indicate temperature, with all remaining bits equal to zero. The least significant byte does not have to be read if that information is not needed. Following power-up or reset, the temperature register value is 0°C until the first conversion is complete.

图 9-11. Temperature Register

15	14	13	12	11	10	9	8
T11	T10	T9	T8	T7	T6	T5	T4
R-0	R-0	R-0	R-0	R-0	R-0	R-0	R-0
7	6	5	4	3	2	1	0
T3	T2	T1	T0	0	0	0	0
R-0	R-0	R-0	R-0	R-0	R-0	R-0	R-0

表 9-7. Temperature Register Field Description

BIT	FIELD	TYPE	RESET	DESCRIPTION
15:4	T[11:0]	R	000h	12-bit, read-only register that stores the most recent temperature conversion results.
3:0	—	R	0h	Not used

9.5.1.2 Configuration Register (address = 01h) [default reset = 00FFh (60A0h TMP1075N)]

The configuration register is an 16-bit read/write register used to store bits that control the operational modes of the temperature sensor. Read and write operations are performed MSB first. 图 9-12 shows the format of the configuration register for the TMP1075, followed by a breakdown of the register bits. The power-up or reset value of the configuration register are all bits equal to 00FFh (TMP1075N: 60A0h). Only single byte writes and reads must be used when pointing to the configuration register for proper operation on the TMP1075N orderable.

图 9-12. Configuration Register: TMP1075

15		14		13		12		11		10		9		8	
OS		R1		R0		F1		F0		POL		TM		SD	
R/W-0		R/W-0		R/W-0		R/W-0		R/W-0		R/W-0		R/W-0		R/W-0	
7		6		5		4		3		2		1		0	
1		1		1		1		1		1		1		1	
R/W-1		R/W-1		R/W-1		R/W-1		R/W-1		R/W-1		R/W-1		R/W-1	

图 9-13. Configuration Register: TMP1075N

15		14		13		12		11		10		9		8	
OS		R1		R0		F1		F0		POL		TM		SD	
R/W-0		R-1		R-1		R/W-0		R/W-0		R/W-0		R/W-0		R/W-0	
7		6		5		4		3		2		1		0	
1		0		x		0		0		0		0		0	
Reserved		Reserved		Reserved		Reserved		Reserved		Reserved		Reserved		Reserved	

表 9-8. Configuration Register Field Description

BIT	FIELD	TYPE	RESET	DESCRIPTION
15	OS	R/W	0	One-shot conversion mode. Writing 1, starts a single temperature conversion. Read returns 0.
14:13	R[1:0]	R/W R (TMP1075N)	0 11 (TMP1075N)	Conversion rate setting when device is in continuous conversion mode 00: 27.5 ms conversion rate 01: 55 ms conversion rate 10: 110 ms conversion rate 11: 220 ms conversion rate (35 ms TMP1075N)
12:11	F[1:0]	R/W	0	Consecutive fault measurements to trigger the alert function 00: 1 fault 01: 2 faults 10: 3 faults (4 faults TMP1075N) 11: 4 faults (6 faults TMP1075N)
10	POL	R/W	0	Polarity of the output pin 0: Active low ALERT pin 1: Active high ALERT pin
9	TM	R/W	0	Selects the function of the ALERT pin 0: ALERT pin functions in comparator mode 1: ALERT pin functions in interrupt mode
8	SD	R/W	0	Sets the device in shutdown mode to conserve power 0: Device is in continuous conversion 1: Device is in shutdown mode
7:0	—	R/W	FFh A0h (TMP1075N)	Not used Reserved on TMP1075N package

Note

The configuration register supports single-byte read and write over I²C bus to ensure software compatibility with other xx75 standard temperature sensors like TMP75 and LM75. When a single byte write is performed, the data byte on the I²C bus updates the register bits 15-8. Similarly when a single byte read is performed, the data bits 15-8 is transferred over the I²C bus.

9.5.1.3 Low Limit Register (address = 02h) [default reset = 4B00h]

The register is configured as a 12-bit, read/write register and data is represented in two's complement format. 图 9-14 shows the layout for T_{LOW} is the same as the temperature register. The default reset value is 4B00h and corresponds to 75°C.

图 9-14. Low Limit Register

15	14	13	12	11	10	9	8
L11	L10	L9	L8	L7	L6	L5	L4
R/W-0	R/W-1	R/W-0	R/W-0	R/W-1	R/W-0	R/W-1	R/W-1
7	6	5	4	3	2	1	0
L3	L2	L1	L0	0	0	0	0
R/W-0	R/W-0	R/W-0	R/W-0	R/W-0	R/W-0	R/W-0	R/W-0

表 9-9. Low Limit Register Field Description

BIT	FIELD	TYPE	RESET	DESCRIPTION
15:4	L[11:0]	R/W	4B0h	12-bit, read-write register that stores the low limit for comparison with temperature results.
3:0	—	R/W	0h	Not used

9.5.1.4 High Limit Register (address = 03h) [default reset = 5000h]

The register is configured as a 12-bit, read/write register and data is represented in two's complement format. 图 9-15 show the layout for T_{HIGH} is the same as the temperature register. The default reset value is 5000h and corresponds to 80°C.

图 9-15. High Limit Register

15	14	13	12	11	10	9	8
H11	H10	H9	H8	H7	H6	H5	H4
R/W-0	R/W-1	R/W-0	R/W-1	R/W-0	R/W-0	R/W-0	R/W-0
7	6	5	4	3	2	1	0
H3	H2	H1	H0	0	0	0	0
R/W-0	R/W-0	R/W-0	R/W-0	R/W-0	R/W-0	R/W-0	R/W-0

表 9-10. High Limit Register Field Description

BIT	FIELD	TYPE	RESET	DESCRIPTION
15:4	H[11:0]	R/W	500h	12-bit, read-write register that stores the high limit for comparison with temperature results.
3:0	—	R/W	0h	Not used

9.5.1.5 Device ID Register (address = 0Fh) [default reset = 7500]

图 9-16 shows this read-only register reads the device ID, and this register only available on the TMP1075 non-N orderables.

图 9-16. Device ID Register

15		14		13		12		11		10		9		8	
DID15		DID14		DID13		DID12		DID11		DID10		DID9		DID8	
R-0		R-1		R-1		R-1		R-0		R-1		R-0		R-1	
7		6		5		4		3		2		1		0	
DID7		DID6		DID5		DID4		DID3		DID2		DID1		DID0	
R-0		R-0		R-0		R-0		R-0		R-0		R-0		R-0	

表 9-11. Device ID Register Field Description

BIT	FIELD	TYPE	RESET	DESCRIPTION
15:0	DID[15:0]	R/W	7500h	16-bit, read-only register that stores the die ID for the device. The MSB reads the static value 75h to indicate the device name for TMP1075

10 Application and Implementation

Note

以下应用部分中的信息不属于 TI 器件规格的范围，TI 不担保其准确性和完整性。TI 的客户应负责确定器件是否适用于其应用。客户应验证并测试其设计，以确保系统功能。

10.1 Application Information

The TMP1075 can measure the PCB temperature of the location where the user mounts the device. The TMP1075 features two-wire SMBus and I²C interface compatibility, with the TMP1075 allowing up to 32 (TMP1075N: 4) devices on one bus. The TMP1075 requires a pullup resistor on the SDA pin, and if needed, on the SCL and ALERT pins. A 0.01- μ F bypass capacitor is also required (see [图 10-1](#)).

10.2 Typical Application



图 10-1. Typical Connections

10.2.1 Design Requirements

The recommended value for the pullup resistor is 5 k Ω . In some applications, the pullup resistor can be lower or higher than 5 k Ω , but the maximum current through the pullup current is recommended to not exceed 3 mA on the SCL and SDA pins. The SCL, SDA, A0, and A1, lines can be pulled up to a supply that is higher than V+. The ALERT line can be pulled up to a supply higher than V+ on the TMP1075 non-N orderables. The A2 pin can only be connected to GND or V+. When the ALERT pin is not used, it can either be connected GND or left floating.

10.2.2 Detailed Design Procedure

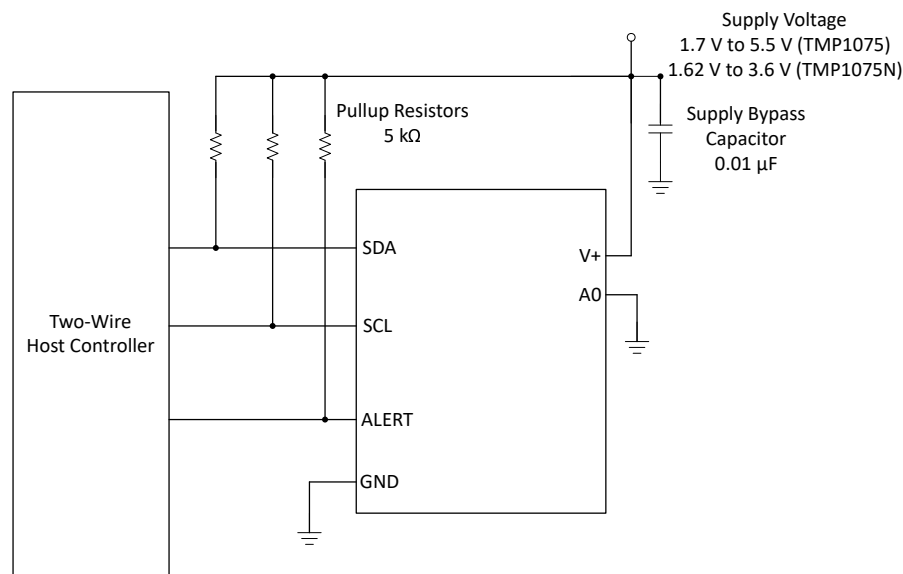
Place the TMP1075 device in close proximity to the heat source that must be monitored with a proper layout for good thermal coupling. This placement ensures that temperature changes are captured within the shortest possible time interval. To maintain accuracy in applications that require air or surface temperature measurement, take care to isolate the package and leads from ambient air temperature. A thermally-conductive adhesive is helpful in achieving accurate surface temperature measurement.

10.2.2.1 Migrating From the xx75 Device Family

The TMP1075 is designed specifically to be a pin-to-pin compatible replacement with xx75 family of devices. This includes considerations for software compatibility. The two byte registers of the TMP1075 dynamically

support single byte read or write, meaning that replacing older xx75 standard temperature sensors should not require any updates to existing code.

10.2.3 Application Curve

For application curves, see [表 10-1](#):

表 10-1. Table of Graphs

FIGURE	TITLE
图 8-9	Sampling Period Change vs. Temperature (1.7 V to 5.5 V)

11 Power Supply Recommendations

The TMP1075 D, DGK, and DSG packages operate with a power supply in the range of 1.7 V to 5.5 V (TMP1075N DRL package operates from 1.62 V to 3.6 V). A power-supply bypass capacitor is required for precision and stability. Place this power-supply bypass capacitor as close to the supply and ground pins of the device as possible. A typical value for this supply bypass capacitor is 0.01 μ F. Applications with noisy or high-impedance power supplies can require a bigger bypass capacitor to reject power-supply noise.

To minimize device self-heating and improve temperature precision, it is recommended to:

- Use the minimum supply voltage rail available
- Avoid communication over I²C bus during ADC conversion
- Use one-shot mode to minimize power consumption
- Set I²C signal levels V_{IL} close to ground and V_{IH} above 90% of V+
- Maintain the I2C bus signals positive edge less than 1 μ s by using a pull-up resistor < 10 k Ω
- Connect the address pins A₀ and A₁ to either ground or V+

12 Layout

12.1 Layout Guidelines

Place the power-supply bypass capacitor as close to the supply and ground pins as possible. The recommended value of this bypass capacitor is 0.01 μ F. Pullup the open-drain output pins SDA and ALERT through 5-k Ω pullup resistors. The SCL requires a pullup resistor only if the microprocessor output is open drain.

12.2 Layout Example



图 12-1. Layout Example (D Package)



图 12-2. Layout Example (DGK Package)

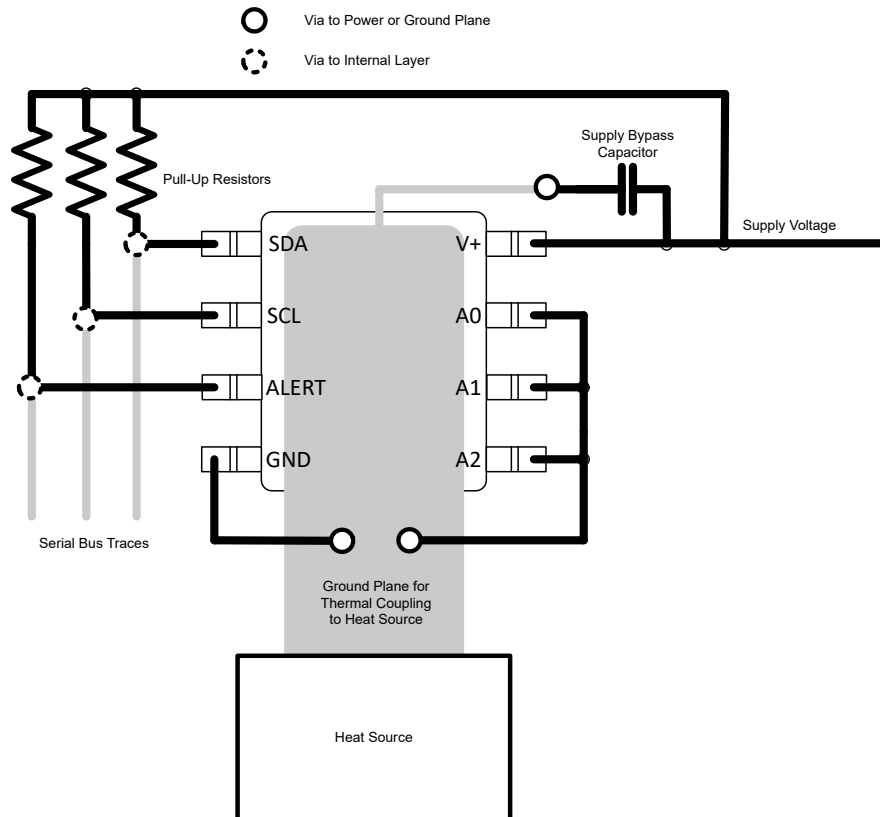

图 12-3. Layout Example (DSG Package)

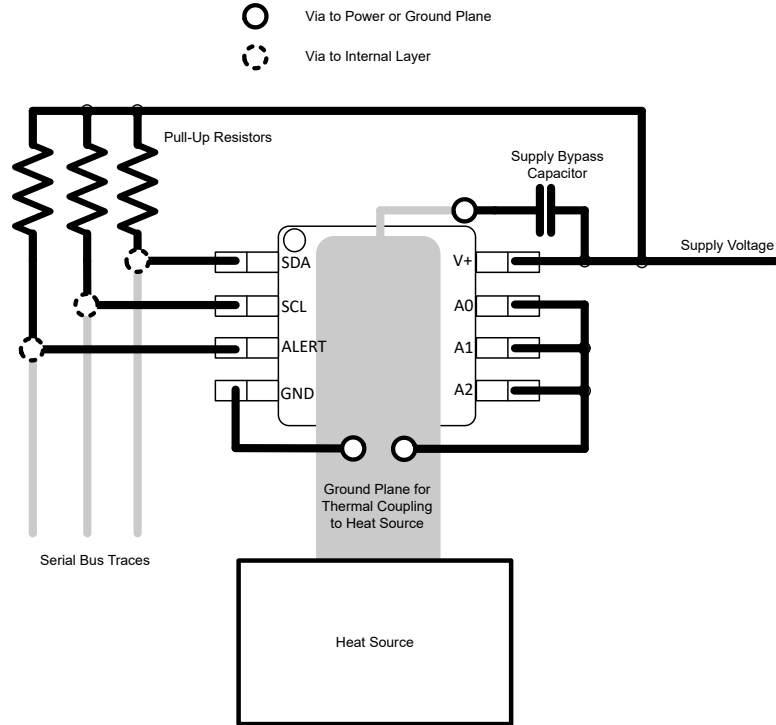

图 12-4. Layout Example (DRL Package)

13 Device and Documentation Support

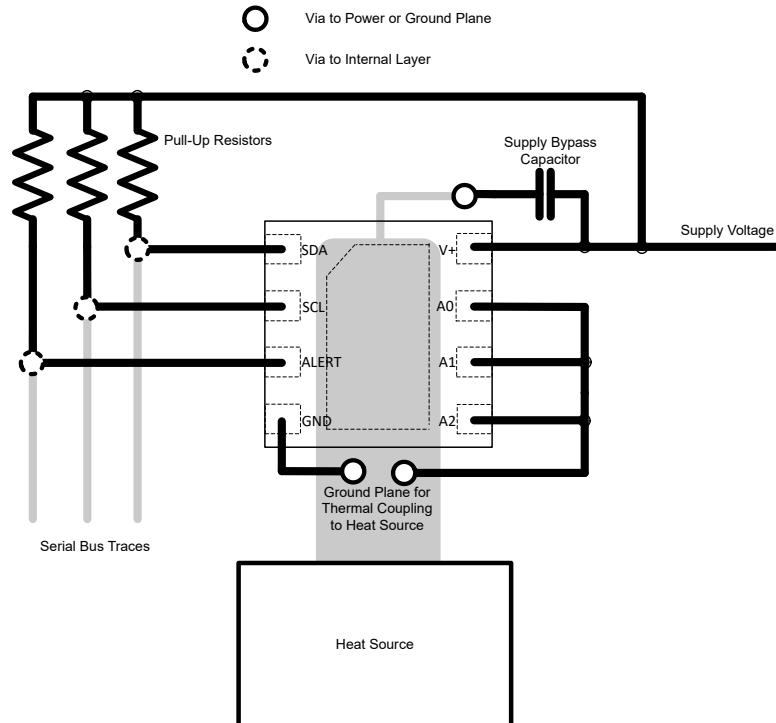
13.1 接收文档更新通知

要接收文档更新通知，请导航至 ti.com 上的器件产品文件夹。点击 [订阅更新](#) 进行注册，即可每周接收产品信息更改摘要。有关更改的详细信息，请查看任何已修订文档中包含的修订历史记录。

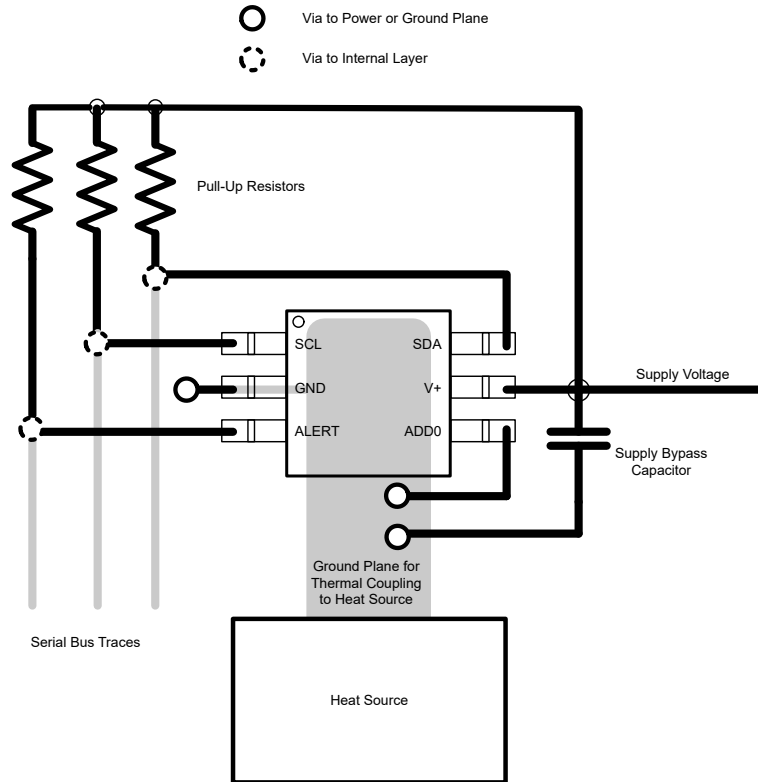
13.2 支持资源

TI E2E™ 支持论坛 是工程师的重要参考资料，可直接从专家获得快速、经过验证的解答和设计帮助。搜索现有解答或提出自己的问题可获得所需的快速设计帮助。

链接的内容由各个贡献者“按原样”提供。这些内容并不构成 TI 技术规范，并且不一定反映 TI 的观点；请参阅 TI 的《[使用条款](#)》。

13.3 Trademarks

TI E2E™ is a trademark of Texas Instruments.
所有商标均为其各自所有者的财产。

13.4 Electrostatic Discharge Caution



This integrated circuit can be damaged by ESD. Texas Instruments recommends that all integrated circuits be handled with appropriate precautions. Failure to observe proper handling and installation procedures can cause damage.

ESD damage can range from subtle performance degradation to complete device failure. Precision integrated circuits may be more susceptible to damage because very small parametric changes could cause the device not to meet its published specifications.

13.5 术语表

TI 术语表 本术语表列出并解释了术语、首字母缩略词和定义。

14 Mechanical, Packaging, and Orderable Information

The following pages include mechanical, packaging, and orderable information. This information is the most current data available for the designated devices. This data is subject to change without notice and revision of this document. For browser-based versions of this data sheet, refer to the left-hand navigation.

重要声明和免责声明

TI 提供技术和可靠性数据 (包括数据表)、设计资源 (包括参考设计)、应用或其他设计建议、网络工具、安全信息和其他资源, 不保证没有瑕疵且不做任何明示或暗示的担保, 包括但不限于对适销性、某特定用途方面的适用性或不侵犯任何第三方知识产权的暗示担保。

这些资源可供使用 TI 产品进行设计的熟练开发人员使用。您将自行承担以下全部责任: (1) 针对您的应用选择合适的 TI 产品, (2) 设计、验证并测试您的应用, (3) 确保您的应用满足相应标准以及任何其他安全、安保或其他要求。这些资源如有变更, 恕不另行通知。TI 授权您仅可将这些资源用于研发本资源所述的 TI 产品的应用。严禁对这些资源进行其他复制或展示。您无权使用任何其他 TI 知识产权或任何第三方知识产权。您应全额赔偿因在这些资源的使用中对 TI 及其代表造成的任何索赔、损害、成本、损失和债务, TI 对此概不负责。

TI 提供的产品受 TI 的销售条款 (<https://www.ti.com/legal/termsofsale.html>) 或 [ti.com](https://www.ti.com) 上其他适用条款/TI 产品随附的其他适用条款的约束。TI 提供这些资源并不会扩展或以其他方式更改 TI 针对 TI 产品发布的适用的担保或担保免责声明。

邮寄地址: Texas Instruments, Post Office Box 655303, Dallas, Texas 75265
Copyright © 2021, 德州仪器 (TI) 公司

PACKAGING INFORMATION

Orderable Device	Status (1)	Package Type	Package Drawing	Pins	Package Qty	Eco Plan (2)	Lead finish/ Ball material (6)	MSL Peak Temp (3)	Op Temp (°C)	Device Marking (4/5)	Samples
TMP1075DGKR	ACTIVE	VSSOP	DGK	8	2500	RoHS & Green	NIPDAUAG SN	Level-2-260C-1 YEAR	-55 to 125	1075	Samples
TMP1075DGKT	OBSOLETE	VSSOP	DGK	8		TBD	Call TI	Call TI	-55 to 125	1075	
TMP1075DR	ACTIVE	SOIC	D	8	2500	RoHS & Green	NIPDAU	Level-1-260C-UNLIM	-55 to 125	1075	Samples
TMP1075DSGR	ACTIVE	WSON	DSG	8	3000	RoHS & Green	NIPDAU	Level-2-260C-1 YEAR	-55 to 125	1AE	Samples
TMP1075DSGT	OBSOLETE	WSON	DSG	8		TBD	Call TI	Call TI	-55 to 125	1AE	
TMP1075NDRLR	ACTIVE	SOT-5X3	DRL	6	4000	RoHS & Green	NIPDAU	Level-1-260C-UNLIM	-40 to 125	N75	Samples
TMP1075NDRLT	OBSOLETE	SOT-5X3	DRL	6		TBD	Call TI	Call TI	-40 to 125	N75	

(1) The marketing status values are defined as follows:

ACTIVE: Product device recommended for new designs.

LIFEBUY: TI has announced that the device will be discontinued, and a lifetime-buy period is in effect.

NRND: Not recommended for new designs. Device is in production to support existing customers, but TI does not recommend using this part in a new design.

PREVIEW: Device has been announced but is not in production. Samples may or may not be available.

OBSOLETE: TI has discontinued the production of the device.

(2) **RoHS:** TI defines "RoHS" to mean semiconductor products that are compliant with the current EU RoHS requirements for all 10 RoHS substances, including the requirement that RoHS substance do not exceed 0.1% by weight in homogeneous materials. Where designed to be soldered at high temperatures, "RoHS" products are suitable for use in specified lead-free processes. TI may reference these types of products as "Pb-Free".

RoHS Exempt: TI defines "RoHS Exempt" to mean products that contain lead but are compliant with EU RoHS pursuant to a specific EU RoHS exemption.

Green: TI defines "Green" to mean the content of Chlorine (Cl) and Bromine (Br) based flame retardants meet JS709B low halogen requirements of <=1000ppm threshold. Antimony trioxide based flame retardants must also meet the <=1000ppm threshold requirement.

(3) MSL, Peak Temp. - The Moisture Sensitivity Level rating according to the JEDEC industry standard classifications, and peak solder temperature.

(4) There may be additional marking, which relates to the logo, the lot trace code information, or the environmental category on the device.

(5) Multiple Device Markings will be inside parentheses. Only one Device Marking contained in parentheses and separated by a "~" will appear on a device. If a line is indented then it is a continuation of the previous line and the two combined represent the entire Device Marking for that device.

(6) Lead finish/Ball material - Orderable Devices may have multiple material finish options. Finish options are separated by a vertical ruled line. Lead finish/Ball material values may wrap to two lines if the finish value exceeds the maximum column width.

Important Information and Disclaimer: The information provided on this page represents TI's knowledge and belief as of the date that it is provided. TI bases its knowledge and belief on information provided by third parties, and makes no representation or warranty as to the accuracy of such information. Efforts are underway to better integrate information from third parties. TI has taken and continues to take reasonable steps to provide representative and accurate information but may not have conducted destructive testing or chemical analysis on incoming materials and chemicals. TI and TI suppliers consider certain information to be proprietary, and thus CAS numbers and other limited information may not be available for release.

In no event shall TI's liability arising out of such information exceed the total purchase price of the TI part(s) at issue in this document sold by TI to Customer on an annual basis.

TAPE AND REEL INFORMATION

QUADRANT ASSIGNMENTS FOR PIN 1 ORIENTATION IN TAPE

*All dimensions are nominal

Device	Package Type	Package Drawing	Pins	SPQ	Reel Diameter (mm)	Reel Width W1 (mm)	A0 (mm)	B0 (mm)	K0 (mm)	P1 (mm)	W (mm)	Pin1 Quadrant
TMP1075DGKR	VSSOP	DGK	8	2500	330.0	12.4	5.3	3.4	1.4	8.0	12.0	Q1
TMP1075DR	SOIC	D	8	2500	330.0	12.4	6.4	5.2	2.1	8.0	12.0	Q1
TMP1075DSGR	WSO	DSG	8	3000	180.0	8.4	2.3	2.3	1.15	4.0	8.0	Q2
TMP1075NDRLR	SOT-5X3	DRL	6	4000	180.0	8.4	2.0	1.8	0.75	4.0	8.0	Q3

TAPE AND REEL BOX DIMENSIONS

*All dimensions are nominal

Device	Package Type	Package Drawing	Pins	SPQ	Length (mm)	Width (mm)	Height (mm)
TMP1075DGKR	VSSOP	DGK	8	2500	366.0	364.0	50.0
TMP1075DR	SOIC	D	8	2500	356.0	356.0	35.0
TMP1075DSGR	WSON	DSG	8	3000	210.0	185.0	35.0
TMP1075NDRLR	SOT-5X3	DRL	6	4000	210.0	185.0	35.0

DRL0006A



PACKAGE OUTLINE

SOT - 0.6 mm max height

PLASTIC SMALL OUTLINE

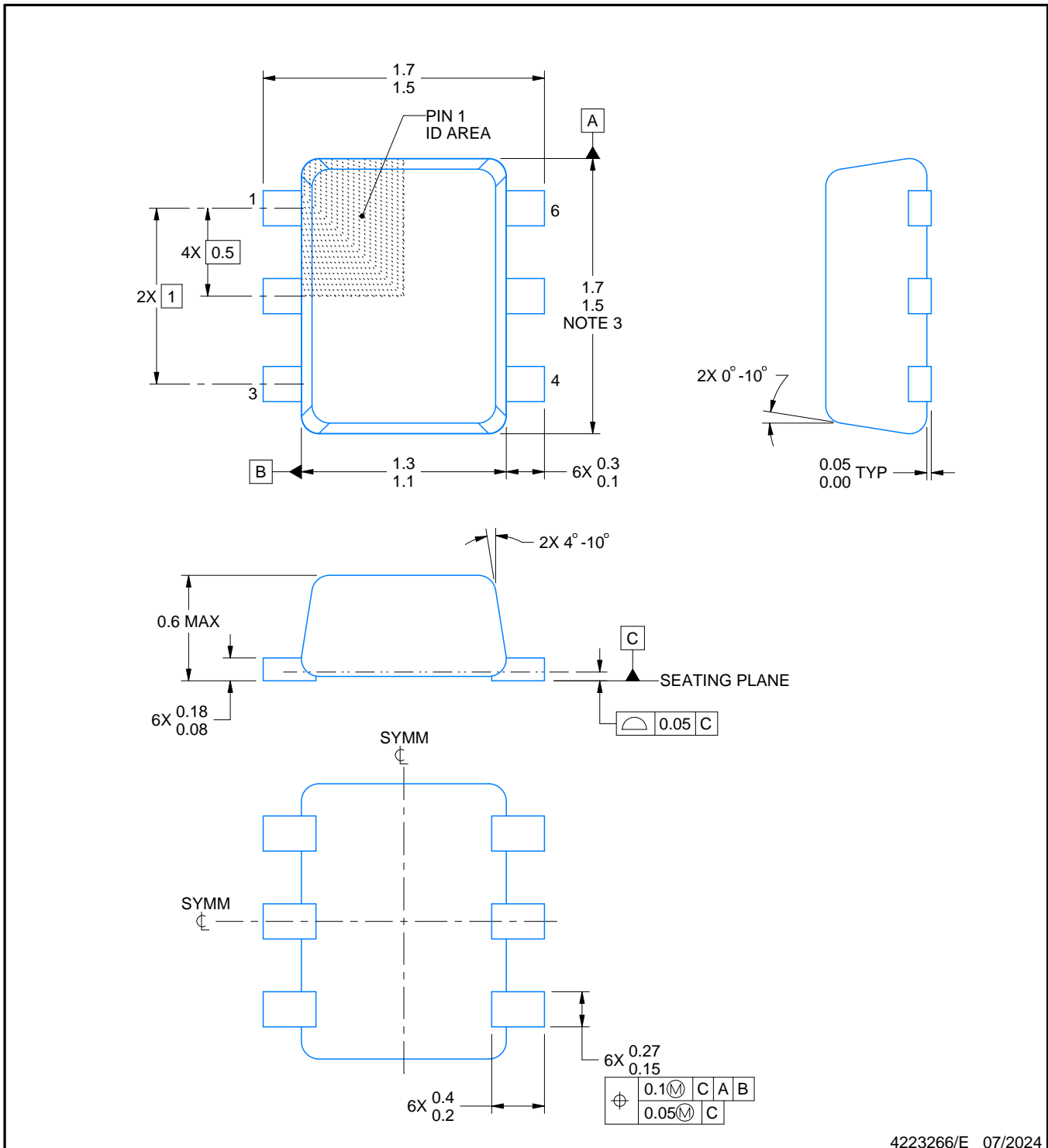

4223266/E 07/2024

NOTES:

- All linear dimensions are in millimeters. Any dimensions in parenthesis are for reference only. Dimensioning and tolerancing per ASME Y14.5M.
- This drawing is subject to change without notice.
- This dimension does not include mold flash, protrusions, or gate burrs. Mold flash, protrusions, or gate burrs shall not exceed 0.15 mm per side.
- Reference JEDEC registration MO-293 Variation UAAD

EXAMPLE BOARD LAYOUT

DRL0006A

SOT - 0.6 mm max height

PLASTIC SMALL OUTLINE



LAND PATTERN EXAMPLE
SCALE:30X



SOLDERMASK DETAILS

4223266/E 07/2024

NOTES: (continued)

5. Publication IPC-7351 may have alternate designs.
6. Solder mask tolerances between and around signal pads can vary based on board fabrication site.
7. Land pattern design aligns to IPC-610, Bottom Termination Component (BTC) solder joint inspection criteria.

EXAMPLE STENCIL DESIGN

DRL0006A

SOT - 0.6 mm max height

PLASTIC SMALL OUTLINE



SOLDER PASTE EXAMPLE
BASED ON 0.1 mm THICK STENCIL
SCALE:30X

4223266/E 07/2024

NOTES: (continued)

8. Laser cutting apertures with trapezoidal walls and rounded corners may offer better paste release. IPC-7525 may have alternate design recommendations.
9. Board assembly site may have different recommendations for stencil design.



D0008A

PACKAGE OUTLINE

SOIC - 1.75 mm max height

SMALL OUTLINE INTEGRATED CIRCUIT



4214825/C 02/2019

NOTES:

1. Linear dimensions are in inches [millimeters]. Dimensions in parenthesis are for reference only. Controlling dimensions are in inches. Dimensioning and tolerancing per ASME Y14.5M.
2. This drawing is subject to change without notice.
3. This dimension does not include mold flash, protrusions, or gate burrs. Mold flash, protrusions, or gate burrs shall not exceed $.006$ [0.15] per side.
4. This dimension does not include interlead flash.
5. Reference JEDEC registration MS-012, variation AA.

EXAMPLE BOARD LAYOUT

D0008A

SOIC - 1.75 mm max height

SMALL OUTLINE INTEGRATED CIRCUIT



LAND PATTERN EXAMPLE
 EXPOSED METAL SHOWN
 SCALE:8X



SOLDER MASK DETAILS

4214825/C 02/2019

NOTES: (continued)

- 6. Publication IPC-7351 may have alternate designs.
- 7. Solder mask tolerances between and around signal pads can vary based on board fabrication site.

EXAMPLE STENCIL DESIGN

D0008A

SOIC - 1.75 mm max height

SMALL OUTLINE INTEGRATED CIRCUIT



SOLDER PASTE EXAMPLE
BASED ON .005 INCH [0.125 MM] THICK STENCIL
SCALE:8X

4214825/C 02/2019

NOTES: (continued)

8. Laser cutting apertures with trapezoidal walls and rounded corners may offer better paste release. IPC-7525 may have alternate design recommendations.
9. Board assembly site may have different recommendations for stencil design.

GENERIC PACKAGE VIEW

DSG 8

WSON - 0.8 mm max height

2 x 2, 0.5 mm pitch

PLASTIC SMALL OUTLINE - NO LEAD

This image is a representation of the package family, actual package may vary.
Refer to the product data sheet for package details.



4224783/A

DSG0008A



PACKAGE OUTLINE

WSON - 0.8 mm max height

PLASTIC SMALL OUTLINE - NO LEAD



ALTERNATIVE TERMINAL SHAPE TYPICAL



SIDE WALL METAL THICKNESS DIM A	
OPTION 1	OPTION 2
0.1	0.2

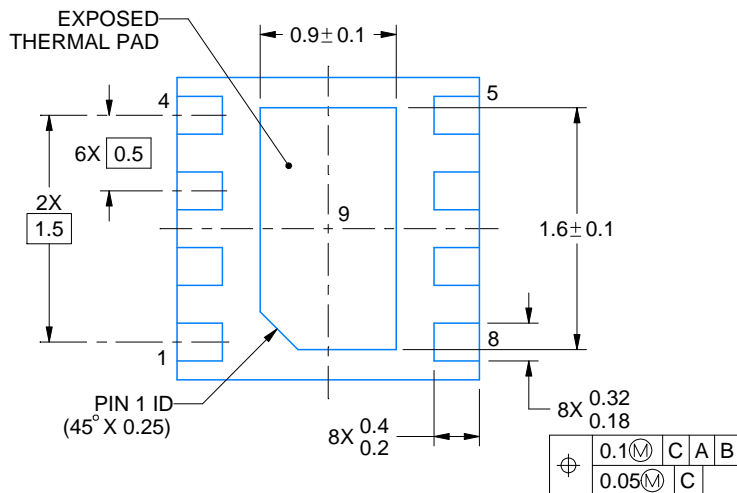

⌀	0.1 M	C	A	B
	0.05 M	C		

4218900/E 08/2022

NOTES:

1. All linear dimensions are in millimeters. Any dimensions in parenthesis are for reference only. Dimensioning and tolerancing per ASME Y14.5M.
2. This drawing is subject to change without notice.
3. The package thermal pad must be soldered to the printed circuit board for thermal and mechanical performance.

EXAMPLE BOARD LAYOUT

DSG0008A

WSON - 0.8 mm max height

PLASTIC SMALL OUTLINE - NO LEAD



LAND PATTERN EXAMPLE
SCALE:20X



SOLDER MASK DETAILS

4218900/E 08/2022

NOTES: (continued)

4. This package is designed to be soldered to a thermal pad on the board. For more information, see Texas Instruments literature number SLUA271 (www.ti.com/lit/slua271).
5. Vias are optional depending on application, refer to device data sheet. If any vias are implemented, refer to their locations shown on this view. It is recommended that vias under paste be filled, plugged or tented.

EXAMPLE STENCIL DESIGN

DSG0008A

WSON - 0.8 mm max height

PLASTIC SMALL OUTLINE - NO LEAD



SOLDER PASTE EXAMPLE
BASED ON 0.125 mm THICK STENCIL

EXPOSED PAD 9:
87% PRINTED SOLDER COVERAGE BY AREA UNDER PACKAGE
SCALE:25X

4218900/E 08/2022

NOTES: (continued)

6. Laser cutting apertures with trapezoidal walls and rounded corners may offer better paste release. IPC-7525 may have alternate design recommendations.

DGK0008A



PACKAGE OUTLINE

VSSOP - 1.1 mm max height

SMALL OUTLINE PACKAGE



NOTES:

PowerPAD is a trademark of Texas Instruments.

1. All linear dimensions are in millimeters. Any dimensions in parenthesis are for reference only. Dimensioning and tolerancing per ASME Y14.5M.
2. This drawing is subject to change without notice.
3. This dimension does not include mold flash, protrusions, or gate burrs. Mold flash, protrusions, or gate burrs shall not exceed 0.15 mm per side.
4. This dimension does not include interlead flash. Interlead flash shall not exceed 0.25 mm per side.
5. Reference JEDEC registration MO-187.

EXAMPLE BOARD LAYOUT

DGK0008A

™ VSSOP - 1.1 mm max height

SMALL OUTLINE PACKAGE



LAND PATTERN EXAMPLE
EXPOSED METAL SHOWN
SCALE: 15X



SOLDER MASK DETAILS

4214862/A 04/2023

NOTES: (continued)

6. Publication IPC-7351 may have alternate designs.
7. Solder mask tolerances between and around signal pads can vary based on board fabrication site.
8. Vias are optional depending on application, refer to device data sheet. If any vias are implemented, refer to their locations shown on this view. It is recommended that vias under paste be filled, plugged or tented.
9. Size of metal pad may vary due to creepage requirement.

EXAMPLE STENCIL DESIGN

DGK0008A

TM VSSOP - 1.1 mm max height

SMALL OUTLINE PACKAGE



SOLDER PASTE EXAMPLE
SCALE: 15X

4214862/A 04/2023

NOTES: (continued)

11. Laser cutting apertures with trapezoidal walls and rounded corners may offer better paste release. IPC-7525 may have alternate design recommendations.
12. Board assembly site may have different recommendations for stencil design.

重要声明和免责声明

TI“按原样”提供技术和可靠性数据（包括数据表）、设计资源（包括参考设计）、应用或其他设计建议、网络工具、安全信息和其他资源，不保证没有瑕疵且不做任何明示或暗示的担保，包括但不限于对适销性、某特定用途方面的适用性或不侵犯任何第三方知识产权的暗示担保。

这些资源可供使用 TI 产品进行设计的熟练开发人员使用。您将自行承担以下全部责任：(1) 针对您的应用选择合适的 TI 产品，(2) 设计、验证并测试您的应用，(3) 确保您的应用满足相应标准以及任何其他功能安全、信息安全、监管或其他要求。

这些资源如有变更，恕不另行通知。TI 授权您仅可将这些资源用于研发本资源所述的 TI 产品的应用。严禁对这些资源进行其他复制或展示。您无权使用任何其他 TI 知识产权或任何第三方知识产权。您应全额赔偿因在这些资源的使用中对 TI 及其代表造成的任何索赔、损害、成本、损失和债务，TI 对此概不负责。

TI 提供的产品受 [TI 的销售条款](#) 或 [ti.com](#) 上其他适用条款/TI 产品随附的其他适用条款的约束。TI 提供这些资源并不会扩展或以其他方式更改 TI 针对 TI 产品发布的适用的担保或担保免责声明。

TI 反对并拒绝您可能提出的任何其他或不同的条款。

邮寄地址：Texas Instruments, Post Office Box 655303, Dallas, Texas 75265

Copyright © 2024，德州仪器 (TI) 公司