

TPS25740B USB Type-C™ 和 USB PD 源控制器

1 特性

- 通过 USB PD 2.0 认证 (TID 编号 1030004) 并符合 USB PD 3.0 标准的供电器件
- 可通过引脚选择传输电压
 - 5V、9V、12V 和 15V
 - 5V、9V、15V 和 20V
- 可通过引脚选择峰值功率设置
 - 8 个选项, 取值范围为 18W 至 100W
- 高电压和安全功能集成
 - 过压、过流、过热保护以及 V_{BUS} 放电
 - CC1 和 CC2 上具有 IEC 61000-4-2 保护
 - 故障状态下快速关断的输入引脚
 - 外部 N 沟道 MOSFET 控制
 - 3 引脚外部电源控制
 - 宽 VIN 电源 (4.65V – 25V)
- 断开时的静态电流低于 10 μ A
- 端口连接指示器
- 用于双端口应用的自定向端口电源管理 功能

2 应用

- USB-PD 适配器 (数据较少)
- 专用充电端口 (数据较少)
- 电源集线器 (数据较少)
- 移动电源
- 点烟器适配器 (CLA)

3 说明

TPS25740B 是完全符合 USB 电力输送 (PD) 2.0 标准且得到认证的解决方案, 可用作 USB 电源 Type-C™ PD。无需固件或外部微控制器, 将其连接至电路板即可使用。因此方便使用并可以最大限度地缩短上市时间。该器件可提供 4 种电压, 电压和功率最高可达 20V/100W。TPS25740B 可使用 CC 引脚自动处理所有 USB PD 协商和握手, 并可使用 CTLx 引脚选择电源电压。使用 PCTRL 引脚可以动态降低宣传的功率以便启用端口电源管理。TPS25740B 集成了 OVP、OCP、ESD、UVLO、OTSD 和 VBUS 放电功能, 从而能够减小解决方案尺寸和节省成本, 实现安全可靠的产品设计。TPS25740B 可控制适用于 VBUS 开关的 N 通道 MOSFET, 相较于需要 P 通道 MOSFET 的解决方案更节省系统成本。TPS25740B 的超低待机功耗使之更易于达到能效标准和延长移动设备中的电池寿命应用。

未连接设备时, TPS25740B 的流耗通常为 8.5 μ A ($V_{DD} = 3.3V$ 时为 5.8 μ A)。此外, 还可以在未连接设备时通过端口连接指示器 (DVDD) 输出来禁用电源, 从而节省更多的系统功耗。

保护 特性 包括过压保护、过流保护、过热保护、CC 引脚上的 IEC 保护以及用于禁用栅极驱动器的系统重写引脚 (\overline{GD})。

器件信息(1)

器件型号	封装	封装尺寸 (标称值)
TPS25740B	VQFN (24)	4.00mm x 4.00mm

(1) 如需了解所有可用封装, 请参阅数据表末尾的可订购产品附录。

简化原理图

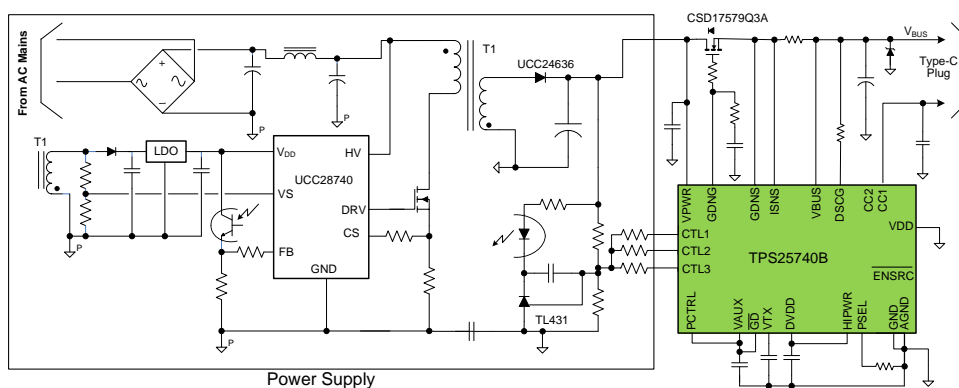

Copyright © 2016, Texas Instruments Incorporated



目录

1	特性	1	9	Application and Implementation	36
2	应用	1	9.1	Application Information.....	36
3	说明	1	9.2	Typical Applications	45
4	修订历史记录	2	9.3	System Examples	52
5	Device Comparison Table	3	10	Power Supply Recommendations	55
6	Pin Configuration and Functions	3	10.1	VDD.....	55
7	Specifications	5	10.2	VPWR	55
7.1	Absolute Maximum Ratings	5	11	Layout	56
7.2	ESD Ratings	5	11.1	Port Current Kelvin Sensing.....	56
7.3	Recommended Operating Conditions.....	6	11.2	Layout Guidelines	56
7.4	Thermal Information	6	11.3	Layout Example	57
7.5	Electrical Characteristics.....	7	12	器件和文档支持	58
7.6	Timing Requirements	10	12.1	文档支持	58
7.7	Switching Characteristics	11	12.2	接收文档更新通知	58
7.8	Typical Characteristics	16	12.3	社区资源	58
8	Detailed Description	18	12.4	商标	58
8.1	Overview	18	12.5	静电放电警告	58
8.2	Functional Block Diagram	20	12.6	术语表	58
8.3	Feature Description.....	20	13	机械、封装和可订购信息	58
8.4	Device Functional Modes.....	35			

4 修订历史记录

注：之前版本的页码可能与当前版本有所不同。

Changes from Revision B (November 2017) to Revision C	Page
• Changed t_{CC} to 1 ms.....	10

Changes from Revision A (September 2017) to Revision B	Page
• 已更改 说明部分.....	1

Changes from Original (June 2017) to Revision A	Page
• 已更改 将“高级信息”更改为“生产数据”	1

5 Device Comparison Table

DEVICE	COMPLIANT USB PD POWER (PDP) OPTIONS	PIN 8	PIN 11	VOLTAGES OFFERED			
				OPTION 1	OPTION 2	OPTION 3	OPTION 4
TPS25740	15 W	$\overline{\text{EN12V}}$	$\overline{\text{UFP}}$	5 V	5 V, 12 V	5 V, 20 V	5 V, 12 V, 20 V
TPS25740A	15 to 45 W	$\overline{\text{EN9V}}$	$\overline{\text{UFP}}$	5 V	5 V, 9 V	5 V, 15 V	5 V, 9 V, 15 V
TPS25740B	15 to 93 W ⁽¹⁾	CTL3	$\overline{\text{ENSRC}}$	5 V, 9 V, 12 V, 15 V	5 V, 9 V, 15 V, 20 V	N/A	N/A

(1) Up to 93 W PDP with a captive cable, and up to 60 W PDP with receptacle.

6 Pin Configuration and Functions

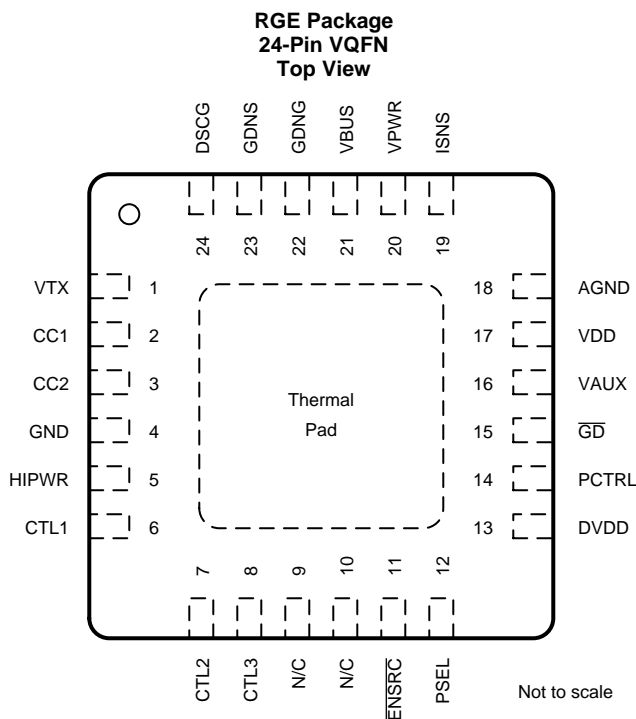

Pin Functions

PIN		I/O	DESCRIPTION
NAME	NO.		
VTX	1	O	Bypass pin for transmit driver supply. Connect this pin to GND via the recommended ceramic capacitor.
CC1	2	I/O	Multifunction configuration channel interface pin to USB Type-C. Functions include connector polarity, end-device connection detect, current capabilities, and PD communication.
CC2	3	I/O	Multifunction configuration channel interface pin to USB Type-C. Functions include connector polarity, end-device connection detect, current capabilities, and PD communication.
GND	4	—	Power ground is associated with power management and gate driver circuits. Connect to AGND and PAD.
HIPWR	5	I	Four-state input pin used to configure the voltages and currents that will be advertised. It may be connected directly to GND or DVDD, or it may be connected to GND or DVDD via a resistance $R_{(SEL)}$.
CTL1	6	O	Digital output pin used to control an external voltage regulator.
CTL2	7	O	Digital output pin used to control an external voltage regulator.
CTL3	8	O	Digital output pin used to control an external voltage regulator.

Pin Functions (continued)

PIN		I/O	DESCRIPTION
NAME	NO.		
N/C	9	—	Connect to GND.
N/C	10	—	Connect to GND.
$\overline{\text{ENSRC}}$	11	O	Open drain output pin used to indicate when the VBUS needs to be sourced.
PSEL	12	I	A four-state input used for selecting the maximum power that can be provided. It may be connected directly to GND or DVDD, or it may be connected to GND or DVDD via a resistance $R_{(\text{SEL})}$.
DVDD	13	O	Internally regulated 1.85 V rail for external use up to 35 mA. Connect this pin to GND via the recommended bypass capacitor.
PCTRL	14	I	Input pin used to control the power that will be advertised. It may be pulled high or low dynamically.
$\overline{\text{GD}}$	15	I	Master enable for the GDNG/GDNS gate driver. The system can drive this low to force the power path switch off.
VAUX	16	O	Internally regulated rail for use by the power management circuits. Connect this pin to GND via the recommended bypass capacitor.
VDD	17	I	Optional input supply.
AGND	18	—	Analog ground associated with monitoring and power conditioning circuits. Connect to GND and PAD.
ISNS	19	I	The ISNS input is used to monitor a VBUS-referenced sense resistor for over-current events.
VPWR	20	I	Connect to an external voltage as a source of bias power. If VDD is supplied, this supply is optional while DVDD is low.
VBUS	21	I	The voltage monitor for the VBUS line.
GDNG	22	O	High-voltage open drain gate driver which may be used to drive NMOS power switches. Connect to the gate terminal.
GDNS	23	I	High-voltage open drain gate driver which may be used to drive NMOS power switches. Connect to the source terminal.
DSCG	24	O	Discharge is an open-drain output that discharges the system VBUS line through an external resistor.
Thermal Pad	—	—	Connect thermal pad to GND / AGND plane.

7 Specifications

7.1 Absolute Maximum Ratings

over operating free-air temperature range (unless otherwise noted)⁽¹⁾

		MIN	MAX	UNIT
Pin voltage (sustained)	VDD, CTL1, CTL2, CTL3, $\overline{\text{ENSRC}}$, PCTRL, CC1, CC2	-0.3	6	V
	VTX ⁽²⁾	-0.3	2.1	V
	VAUX ⁽²⁾	-0.3	4.5	V
	$\overline{\text{GD}}$ ⁽³⁾	-0.3	7	V
	HIPWR, PSEL, DVDD ⁽²⁾	-0.3	2.1	V
	GDNG ⁽²⁾	-0.5	40	V
	VBUS, VPWR, ISNS, DSCG, GDNS	-0.5	30	V
Pin voltage (transient for 1ms)	VBUS, VPWR, ISNS, DSCG, GDNS	-1.5	30	V
Pin-to-pin voltage	$V_{(\text{GDNG})} - V_{(\text{GDNS})}$	-0.3	20	V
	AGND to GND	-0.3	0.3	V
	ISNS to VBUS	-0.3	0.3	V
Sinking current (average)	CTL1, CTL2, CTL3, $\overline{\text{ENSRC}}$		8	mA
	$\overline{\text{GD}}$		100	μA
	DSCG		10	mA
Sinking current (transient, 50 ms pulse 0.25% duty cycle)	DSCG		375	mA
Current sourcing	VTX	Internally limited		mA
	CC1, CC2	Internally limited		mA
	VAUX	0	25	μA
Operating junction temperature range, T _J		-40	125	°C
Storage temperature, T _{stg}		-65	150	°C

- (1) Stresses beyond those listed under *Absolute Maximum Ratings* may cause permanent damage to the device. These are stress ratings only, which do not imply functional operation of the device at these or any other conditions beyond those indicated under *Recommended Operating Conditions*. Exposure to absolute-maximum-rated conditions for extended periods may affect device reliability.
- (2) Do not apply voltage to these pins.
- (3) Voltage allowed to rise above Absolute Maximum provided current is limited.

7.2 ESD Ratings⁽¹⁾

		VALUE	UNIT
V _(ESD) Electrostatic discharge	Human-body model (HBM), per ANSI/ESDA/JEDEC JS-001 ⁽²⁾	±2500	V
	Charged-device model (CDM), per JEDEC specification JESD22-C101 ⁽³⁾	±1000	
	IEC ⁽⁴⁾ 61000-4-2 contact discharge, CC1, CC2	±8000	
	IEC ⁽⁴⁾ 61000-4-2 air-gap discharge, CC1, CC2	±15000	

- (1) This integrated circuit can be damaged by ESD. Texas Instruments recommends that all integrated circuits be handled with appropriate precautions. Failure to observe proper handling and installation procedures can cause damage.
- (2) JEDEC document JEP155 states that 500-V HBM allows safe manufacturing with a standard ESD control process.
- (3) JEDEC document JEP157 states that 250-V CDM allows safe manufacturing with a standard ESD control process.
- (4) These results were passing limits that were obtained on an application-level test board. Individual results may vary based on implementation. Surges per IEC61000-4-2, 1999 applied between CC1/CC2 and ground of TPS25740BEVM-741 and TPS25740BEVM-741

7.3 Recommended Operating Conditions

over operating free-air temperature range (unless otherwise noted)

			MIN	NOM	MAX	UNIT
V _{IN}	Supply voltage	VDD	0		5.5	V
		VPWR	4.65		25	V
V _I	Applied voltage	PCTRL, CC1, CC2, CTL1, CTL2, CTL3	0		5.5	V
		$\overline{\text{GD}}$	0		6.5	V
		DSCG, GDNS, VBUS	0		25	V
		HIPWR, PSEL	0		DVDD	V
V _I	Pin-to-pin voltage	ISNS - VBUS	-0.1		0.1	V
V _{IH}	High level input voltage	$\overline{\text{GD}}$	2		1.6	V
		PCTRL				V
V _{IL}	Low level input voltage	$\overline{\text{GD}}$			1.6	V
		PCTRL				V
I _S	Sinking current	CTL1, CTL2, CTL3, $\overline{\text{ENSRC}}$			1.5	μA
		$\overline{\text{GD}}$			80	μA
		DSCG, transient sinking current 50 ms pulse, 0.25% duty cycle			350	mA
		DSCG, average			5	mA
C _S	Shunt capacitance	CC1, CC2 (C _(RX))	200	560	600	pF
		VBUS (C _(PDIN))			10	μF
		DVDD (C _(DVDD))	0.198	0.22	0.242	μF
		VAUX (C _(VAUX))	0.09	0.1	0.11	μF
		VTX (C _(VTX))	0.09	0.10	0.11	μF
		VDD (C _(VDD))	0.09			μF
R _S	Sense resistance	Configured for 3 A		5	6.4	mΩ
		Configured for 5 A		5	5.8	mΩ
R _(PUD)	Pull up/down resistance	HIPWR, PSEL (direct to GND or direct to DVDD)	0		1	kΩ
		HIPWR, PSEL (R _(SEL))	80	100	120	kΩ
R _(DSCG)	Series resistance	Maximum VBUS voltage of 25 V	80			Ω
		Maximum VBUS voltage of 15 V	43			Ω
		Maximum VBUS voltage of 6 V	20			Ω
T _J	Operating junction temperature				125	°C

7.4 Thermal Information

THERMAL METRIC ⁽¹⁾		TPS25740B	UNIT
		RGE (VQFN)	
		24 PINS	
R _{θJA}	Junction-to-ambient thermal resistance	33	°C/W
R _{θJC(top)}	Junction-to-case (top) thermal resistance	32.6	°C/W
R _{θJB}	Junction-to-board thermal resistance	10	°C/W
ψ _{JT}	Junction-to-top characterization parameter	0.4	°C/W
ψ _{JB}	Junction-to-board characterization parameter	10	°C/W
R _{θJC(bot)}	Junction-to-case (bottom) thermal resistance	2.6	°C/W

(1) For more information about traditional and new thermal metrics, see the [Semiconductor and IC Package Thermal Metrics](#) application report.

7.5 Electrical Characteristics

Unless otherwise stated in a specific test condition the following conditions apply: $-40^{\circ}\text{C} \leq T_J \leq 125^{\circ}\text{C}$; $3 \leq V_{DD} \leq 5.5\text{ V}$, $4.65\text{ V} \leq V_{PWR} \leq 25\text{ V}$; $HIPWR = \text{GND}$, $PSEL = \text{GND}$, $\overline{\text{GD}} = \text{VAUX}$, $\text{PCTRL} = \text{VAUX}$, $\text{AGND} = \text{GND}$; VAUX , VTX , bypassed with $0.1\ \mu\text{F}$, DVDD bypassed with $0.22\ \mu\text{F}$; all other pins open (unless otherwise noted)

PARAMETER		TEST CONDITIONS	MIN	TYP	MAX	UNIT
Voltage Comparator (VBUS)						
$V_{(\text{VBUS_RTH})}$	VBUS threshold (Rising voltage)		4.25	4.45	4.65	V
$V_{(\text{VBUS_FTH})}$	VBUS threshold (Falling voltage)		3.5	3.7	3.9	V
	VBUS threshold (Hysteresis)			0.75		V
Power Supply (VDD, VPWR)						
$V_{(\text{VDD_TH})}$	VDD UVLO threshold	Rising voltage	2.8	2.91	2.97	V
		Falling voltage	2.8	2.86	2.91	
		Hysteresis, comes into effect once the rising threshold is crossed.		0.05		
$V_{(\text{VPWR_RTH})}$	VPWR UVLO threshold rising	Rising voltage	4.2	4.45	4.65	V
$V_{(\text{VPWR_FTH})}$	VPWR UVLO threshold falling	Falling voltage	3.5	3.7	3.9	V
	VPWR UVLO threshold hysteresis	Hysteresis, comes into effect once the rising threshold is crossed.		0.75		V
	Supply current drawn from VDD in sleep mode	VPWR = 0 V, VDD = 5 V, CC1 and CC2 pins are open.		9.2	20	μA
		VPWR = 0 V, VDD = 5 V, CC1 pin open, CC2 pin tied to GND.		94	150	μA
	Supply current drawn from VPWR in sleep mode	VPWR = 5 V, VDD = 0 V, CC1 and CC2 pins are open.		8.5	15	μA
		VPWR = 5 V, VDD = 0 V, CC1 pin open, CC2 pin tied to GND.		90	140	μA
$I_{(\text{SUPP})}$	Operating current while sink attached	PD Sourcing active, VBUS = 5 V, VPWR = 5 V, VDD = 3.3 V	1	1.8	3	mA
Over/Under Voltage Protection (VBUS)						
$V_{(\text{FOVP})}$	Fast OVP threshold, always enabled	5 V PD contract	5.8	6.05	6.3	V
		9 V PD contract	10.1	10.55	11.0	V
		12 V PD contract	13.2	13.75	14.3	V
		15 V PD contract	16.2	16.95	17.7	V
		20 V PD contract	22.1	23.05	24.0	V
$V_{(\text{SOVP})}$	Slow OVP threshold, disabled during voltage transitions. (See Figure 1)	5 V PD contract	5.5	5.65	5.8	V
		9 V PD contract	10	10.2	10.4	V
		12 V PD contract	13.1	13.4	13.7	V
		15 V PD contract	16.3	16.5	17	V
		20 V PD contract	21.5	22.0	22.5	V
$V_{(\text{SUVP})}$	UVP threshold, disabled during voltage transitions (See Figure 1)	5 V PD contract	3.5	3.65	3.8	V
		9 V PD contract	6.8	6.95	7.1	V
		12 V PD contract	9.2	9.45	9.7	V
		15 V PD contract	11.7	11.95	12.2	V
		20 V PD contract	15.7	16.1	16.5	V
VAUX						
$V_{(\text{VAUX})}$	Output voltage	$0 \leq I_{(\text{VAUX})} \leq I_{(\text{VAUXEXT})}$	2.875	3.2	4.1	V
	VAUX current limit		1		5	mA
$I_{(\text{VAUXEXT})}$	External load that may be applied to VAUX.				25	μA
DVDD						
$V_{(\text{DVDD})}$	Output voltage	$0\text{ mA} \leq I_{(\text{DVDD})} \leq 35\text{ mA}$, CC1 or CC2 pulled to ground via $5.1\text{ k}\Omega$, or both CC1 and CC2 pulled to ground via $1\text{ k}\Omega$	1.75	1.85	1.95	V
	Load regulation	Overshoot from $V_{(\text{DVDD})}$, 10-mA minimum, $0.198\text{-}\mu\text{F}$ bypass capacitor	1.7		2	V
	Current limit	DVDD tied to GND	40		150	mA

Electrical Characteristics (continued)

Unless otherwise stated in a specific test condition the following conditions apply: $-40^{\circ}\text{C} \leq T_J \leq 125^{\circ}\text{C}$; $3 \leq V_{DD} \leq 5.5 \text{ V}$, $4.65 \text{ V} \leq V_{PWR} \leq 25 \text{ V}$; $\text{HIPWR} = \text{GND}$, $\text{PSEL} = \text{GND}$, $\overline{\text{GD}} = \text{VAUX}$, $\text{PCTRL} = \text{VAUX}$, $\text{AGND} = \text{GND}$; VAUX , VTX , bypassed with $0.1 \mu\text{F}$, DVDD bypassed with $0.22 \mu\text{F}$; all other pins open (unless otherwise noted)

PARAMETER		TEST CONDITIONS	MIN	TYP	MAX	UNIT
VTX						
	Output voltage	Not transmitting or receiving, 0 to 2 mA external load	1.050	1.125	1.200	V
	Current limit	VTX tied to GND	2.5		10	mA
Gate Driver Disable ($\overline{\text{GD}}$)						
$V_{(\text{GD_TH})}$	Input enable threshold voltage	Rising voltage	1.64	1.725	1.81	V
		Hysteresis		0.15		V
$V_{(\text{GDC})}$	Internal clamp voltage	$I_{(\overline{\text{GD}})} = 80 \mu\text{A}$	6.5	7	8.5	V
$R_{(\text{GD})}$	Internal pulldown resistance	From 0 V to 6 V	3	6	9.5	M Ω
Discharge (DSCG) ⁽¹⁾⁽²⁾						
$V_{(\text{DSCGT})}$	ON state (linear)	$I_{(\text{DSCG})} = 100 \text{ mA}$	0.15	0.42	1	V
$I_{(\text{DSCGT})}$	ON state (saturation)	$V_{(\text{DSCG})} = 4 \text{ V}$, pulsed mode operation	220	553	1300	mA
$R_{(\text{DSCGB})}$	Discharge bleeder	While CC1 is pulled down by 5.1 k Ω and CC2 is open, $V_{(\text{DSCG})} = 25 \text{ V}$	6.6	8.2	10	k Ω
	Leakage current	$0 \text{ V} \leq V_{(\text{DSCG})} \leq 25 \text{ V}$			2	μA
N-ch MOSFET Gate Driver (GDNG, GDNS)						
$I_{(\text{GDNON})}$	Sourcing current	$0 \text{ V} \leq V_{(\text{GDNS})} \leq 25 \text{ V}$, $0 \text{ V} \leq V_{(\text{GDNG})} - V_{(\text{GDNS})} \leq 6 \text{ V}$	13.2	20	30	μA
$V_{(\text{GDNON})}$	Sourcing voltage while enabled ($V_{(\text{GDNG})} - V_{(\text{GDNS})}$)	$0 \text{ V} \leq V_{(\text{GDNS})} \leq 25 \text{ V}$, $I_{(\text{GDNON})} \leq 4 \mu\text{A}$, $V_{DD} = 0 \text{ V}$	8.5		12	V
$R_{(\text{GDNGOFF})}$	Sinking strength while disabled	$V_{(\text{GDNG})} - V_{(\text{GDNS})} = 0.5 \text{ V}$, $0 \leq V_{(\text{GDNS})} \leq 25 \text{ V}$		150	300	Ω
	Sinking strength UVLO (safety)	$V_{DD} = 1.4 \text{ V}$, $V_{(\text{GDNG})} = 1 \text{ V}$, $V_{(\text{GDNS})} = 0 \text{ V}$, $V_{PWR} = 0 \text{ V}$		145		μA
		$V_{PWR} = 1.4 \text{ V}$, $V_{(\text{GDNG})} = 1 \text{ V}$, $V_{(\text{GDNS})} = 0 \text{ V}$, $V_{DD} = 0 \text{ V}$			145	
	Off-state leakage	$V_{(\text{GDNS})} = 25 \text{ V}$, $V_{(\text{GDNG})}$ open			7	μA
Power Control Input (PCTRL)						
$V_{(\text{PCTRL_TH})}$	Threshold voltage ⁽³⁾	Voltage rising	1.65	1.75	1.85	V
		Hysteresis		100		mV
	Input resistance	$0 \text{ V} \leq V_{(\text{PCTRL})} \leq V_{(\text{VAUX})}$	1.5	2.9	6	M Ω
Voltage Select (HIPWR), Power Select (PSEL)⁽⁴⁾						
	Leakage current	$0 \text{ V} \leq V_{(\text{HIPWR})} \leq V_{(\text{DVDD})}$, $0 \text{ V} \leq V_{(\text{PSEL})} \leq V_{(\text{DVDD})}$	-1		1	μA
Port Status and Voltage Control (CTL1, CTL2, CTL3, ENSRC)⁽⁵⁾						
V_{OL}	Output low voltage	$I_{\text{OL}} = 4 \text{ mA}$ sinking			0.4	V
	Leakage current ⁽⁶⁾	In Hi-Z state, $0 \leq V_{(\text{CTLx})} \leq 5.5 \text{ V}$ or $0 \leq V_{\text{ENSRC}} \leq 5.5 \text{ V}$	-0.5		0.5	μA
Transmitter Specifications (CC1, CC2)						
R_{TX}	Output resistance (zDriver from USB PD in 文档支持)	During transmission	33	45	75	Ω
$V_{(\text{TXHI})}$	Transmit high voltage	External Loading per Figure 27	1.05	1.125	1.2	V
$V_{(\text{TXLO})}$	Transmit low voltage	External Loading per Figure 27	-75		75	mV
Receiver Specifications (CC1, CC2)						
$V_{(\text{RXHI})}$	Receive threshold (rising)		800	840	885	mV
$V_{(\text{RXLO})}$	Receive threshold (falling)		485	525	570	mV
	Receive threshold (Hysteresis)			315		mV

(1) If T_{J1} is perceived to have been exceeded an OTSD occurs and the discharge FET is disabled.

(2) The discharge pull-down is not active in the sleep mode.

(3) When voltage on the PCTRL pin is less than $V_{(\text{PCTRL_TH})}$, the amount of power advertised is reduced by half.

(4) Leaving HIPWR or PSEL open is an undetermined state and leads to unpredictable behavior.

(5) These pins are high-z during a UVLO, reset, or in Sleep condition.

(6) The pins were designed for less leakage, but testing only verifies that the leakage does not exceed $0.5 \mu\text{A}$.

Electrical Characteristics (continued)

Unless otherwise stated in a specific test condition the following conditions apply: $-40^{\circ}\text{C} \leq T_J \leq 125^{\circ}\text{C}$; $3 \leq V_{DD} \leq 5.5 \text{ V}$, $4.65 \text{ V} \leq V_{PWR} \leq 25 \text{ V}$; $\text{HIPWR} = \text{GND}$, $\text{PSEL} = \text{GND}$, $\overline{\text{GD}} = \text{VAUX}$, $\text{PCTRL} = \text{VAUX}$, $\text{AGND} = \text{GND}$; VAUX , VTX , bypassed with $0.1 \mu\text{F}$, DVDD bypassed with $0.22 \mu\text{F}$; all other pins open (unless otherwise noted)

PARAMETER		TEST CONDITIONS	MIN	TYP	MAX	UNIT
$V_{(\text{INT})}$	Amplitude of interference that can be tolerated	Interference is 600 kHz square wave, rising 0 to 100 mV.			100	mV
		Interference is 1 MHz sine wave			1	V_{PP}
DFP Specifications (CC1, CC2)						
$V_{(\text{DSTD})}$	Detach threshold when cable is detached.	In standard Rp mode ⁽⁷⁾ , voltage rising	1.52	1.585	1.65	V
		Hysteresis		0.02		V
$V_{(\text{D1.5})}$		In 1.5 A Rp mode ⁽⁸⁾ , voltage rising	1.52	1.585	1.65	V
		Hysteresis		0.02		V
$V_{(\text{D3.0})}$		In 3 A Rp mode ⁽⁹⁾ , voltage rising	2.50	2.625	2.75	V
		Hysteresis		0.05		V
$V_{(\text{OCN})}$	Unloaded output voltage on CC pin	normal mode	2.75		4.35	V
$V_{(\text{OCDS})}$		$V_{PWR} = 0 \text{ V}$ (in UVLO) or in sleep mode	1.8		5.5	V
$I_{(\text{RPSTD})}$	Loaded output current while connected through CCx	In standard Rp mode1, CCy open, $0 \text{ V} \leq V_{CCx} \leq 1.5 \text{ V}$ (vRd)	64	80	96	μA
$I_{(\text{RP1.5})}$		In 1.5 A Rp mode 2, CCy open, $0 \text{ V} \leq V_{CCx} \leq 1.5 \text{ V}$ (vRd)	166	180	194	μA
$I_{(\text{RP3.0})}$		In 3 A Rp mode 3, CCy open, $0 \text{ V} \leq V_{CCx} \leq 1.5 \text{ V}$ (vRd)	304	330	356	μA
$V_{(\text{RDSTD})}$	Ra, Rd detection threshold (falling)	In standard Rp mode1, $0 \text{ V} \leq V_{CCx} \leq 1.5 \text{ V}$ (vRd)	0.15	0.19	0.23	V
		Hysteresis		0.02		V
$V_{(\text{RD1.5})}$		In 1.5 A Rp mode2, CCy open $0 \text{ V} \leq V_{CCx} \leq 1.5 \text{ V}$ (vRd)	0.35	0.39	0.43	V
		Hysteresis		0.02		V
$V_{(\text{RD3.0})}$		In 3 A Rp mode3, CCy open $0 \text{ V} \leq V_{CCx} \leq 1.5 \text{ V}$ (vRd)	0.75	0.79	0.83	V
		Hysteresis		0.02		V
$V_{(\text{WAKE})}$	Wake threshold (rising and falling), exit from sleep mode	$V_{PWR} = 4.65 \text{ V}$, $0 \text{ V} \leq V_{DD} \leq 3 \text{ V}$ ⁽¹⁰⁾	1.6		3.0	V
$I_{(\text{DSDFP})}$	Output current on CCx in sleep mode to detect Ra removal	$\text{CCx} = 0\text{V}$, CCy floating	40	73	105	μA
OverCurrent Protection (ISNS, VBUS)						
$V_{(\text{TRIP})}$	Current trip shunt voltage	Specified as $V_{(\text{ISNS})} - V_{(\text{VBUS})}$. 3.5 V ⁽¹¹⁾ $\leq V_{\text{BUS}} \leq 25 \text{ V}$				
		HIPWR: 5 A not enabled	19.2		22.6	mV
		HIPWR = DVDD (5 A enabled)	29		34	mV
OTSD						
T_{J1}	Die temperature (Analog) ⁽¹²⁾	$T_J \uparrow$	125	135	145	$^{\circ}\text{C}$
		Hysteresis		10		
T_{J2}	Die temperature (Analog) ⁽¹³⁾	$T_J \uparrow$	140	150	163	$^{\circ}\text{C}$
		Hysteresis		10		

(7) Standard Rp mode is active after a USB Type-C sink, debug accessory, or audio accessory is attached until the first USB PD message is transmitted (after GDNG has been enabled).

(8) 1.5 A Rp mode is active after a USB PD message is received.

(9) 3 A Rp mode is active after GDNG has been enabled until a USB PD message is received.

(10) $V_{\text{WAKE}} < V_{\text{OCDS}}$ is always true.

(11) Common mode minimum aligns to VBUS UVLO. VBUS must be above its UVLO for the OCP function to be active.

(12) When T_{J1} trips a hard reset is transmitted and discharge is disabled, but the bleed discharge is not disabled.

(13) T_{J2} trips only when some external heat source drives the temperature up. When it trips the DVDD, and VAUX power outputs are turned off.

7.6 Timing Requirements

Unless otherwise stated in a specific test condition the following conditions apply: $-40^{\circ}\text{C} \leq T_J \leq 125^{\circ}\text{C}$; $3 \leq V_{DD} \leq 5.5 \text{ V}$, $4.65 \text{ V} \leq V_{PWR} \leq 25 \text{ V}$; $\text{HIPWR} = \text{GND}$, $\text{PSEL} = \text{GND}$, $\overline{\text{GD}} = \text{VAUX}$, $\text{CTRL} = \text{VAUX}$, $\text{AGND} = \text{GND}$; VAUX , VTX , bypassed with $0.1 \mu\text{F}$, DVDD bypassed with $0.22 \mu\text{F}$; all other pins open (unless otherwise noted)

		MIN	NOM	MAX	UNIT
t_{FOVPDG}	Deglintch for fast over-voltage protection		5		μs
t_{OCP}	Deglintch filter for over-current protection			15	μs
	Time power is applied until CC1 and CC2 pull-ups are applied.		2.5	4	ms
		$V_{(\text{VPWR})} > V_{(\text{VPWR_TH})}$ OR $V_{(\text{VDD})} > V_{(\text{VDD_TH})}$			
t_{CC}	Falling/Rising voltage deglintch time for detection on CC1 and CC2		1		ms
Transmitter Specifications (CC1, CC2)					
t_{UI}	Bit unit Interval	3.05	3.3	3.70	μs
	Rise/fall time, t_{Fall} and t_{Rise} (refer to USB PD in 文档支持)	External Loading per Figure 27		600	ns

7.7 Switching Characteristics

Unless otherwise stated in a specific test condition the following conditions apply: $-40^{\circ}\text{C} \leq T_J \leq 125^{\circ}\text{C}$; $3 \leq V_{DD} \leq 5.5\text{ V}$, $4.65\text{ V} \leq V_{PWR} \leq 25\text{ V}$; $\text{HIPWR} = \text{GND}$, $\text{PSEL} = \text{GND}$, $\overline{\text{GD}} = \text{VAUX}$, $\text{PCTRL} = \text{VAUX}$, $\text{AGND} = \text{GND}$; VAUX , VTX , bypassed with $0.1\ \mu\text{F}$, DVDD bypassed with $0.22\ \mu\text{F}$; all other pins open (unless otherwise noted)

PARAMETER		TEST CONDITIONS	MIN	TYP	MAX	UNIT
t_{VP}	Delay from enabling external NFET until under-voltage and OCP protection are enabled	$\text{VBUS} = \text{GND}$		190		ms
t_{STL}	Source settling time, time from CTL1, CTL2, or CTL3 being changed until a PS_RDY USB PD message is transmitted to inform the sink is may draw full current. (refer to USB PD in 文档支持)			260		ms
t_{SR}	Time that GDNG is disabled after a hard reset. This is $t_{\text{SrcRecover}}$. (refer to USB PD in 文档支持)	$T_J > T_{J1}$		765		ms
t_{HR}	Time after hard reset is transmitted until GDNG is disabled. This is $t_{\text{PSHardReset}}$. (refer to USB PD in 文档支持)			30		ms
t_{CCDeb}	Time until $\overline{\text{ENSRC}}$ is pulled low after sink attachment, this is the USB Type-C required debounce time for attachment detection called $t_{\text{CCDebounce}}$. (refer to USB Type-C in 文档支持)			185		ms
t_{ST}	Delay after sink request is accepted until CTL1, CTL2, or CTL3 is changed. This is called $t_{\text{SnkTransition}}$. (refer to USB PD in 文档支持)			30		ms
t_{FLT}	The time in between hard reset transmissions in the presence of a persistent supply fault.	$\overline{\text{GD}} = \text{GND}$ or $\text{VPWR} = \text{GND}$, sink attached		1395		ms
t_{SH}	The time in between retries (hard reset transmissions) in the presence of a persistent VBUS short.	$\text{VBUS} = \text{GND}$, sink attached		985		ms
t_{ON}	The time from $\overline{\text{ENSRC}}$ being pulled low until a hard reset is transmitted. Designed to be greater than $t_{\text{SrcTurnOn}}$. (refer to USB PD in 文档支持)	$\overline{\text{GD}} = 0\text{ V}$ or $\text{VPWR} = 0\text{ V}$		600		ms
	Retry interval if USB PD sink stops communicating without being removed or if sink does not communicate after a fault condition. Time GDNG remains enabled before a hard reset is transmitted. This is the $t_{\text{NoResponse}}$ time. (refer to USB PD in 文档支持)	Sink attached		4.8		s
t_{DVDD}	Delay before DVDD is driven high	After sink attached			5	ms
t_{GDoff}	Turnoff delay, time until $V_{(\text{GDNG})}$ is below 10% of its initial value after the GD pin is low	$\overline{\text{VGD}}: 5\text{ V} \rightarrow 0\text{ V}$ in $< 0.5\ \mu\text{s}$			5	μs
t_{FOVP}	Response time when VBUS exceeds the fast-OVP threshold	$\text{VBUS} \uparrow$ to GDNG OFF ($V_{(\text{GDNG})}$ below 10% its initial value)			30	μs
	OCP large signal response time	5 A enabled, $V_{(\text{ISNS})} - V_{(\text{VBUS})}: 0\text{ V} \rightarrow 42\text{ mV}$ measured to GDNG transition start			30	μs
	Time until discharge is stopped after T_{J1} is exceeded.	$0\text{ V} \leq V_{(\text{DSCG})} \leq 25\text{ V}$			10	μs
	Digital output fall time	$V_{(\text{PULLUP})} = 1.8\text{ V}$, $C_L = 10\text{ pF}$, $R_{(\text{PULLUP})} = 10\text{ k}\Omega$, $V_{(\text{CTLx})}$ or $V_{(\text{ENSRC})}: 70\% V_{\text{PULLUP}} \rightarrow 30\% V_{\text{PULLUP}}$	20		300	ps

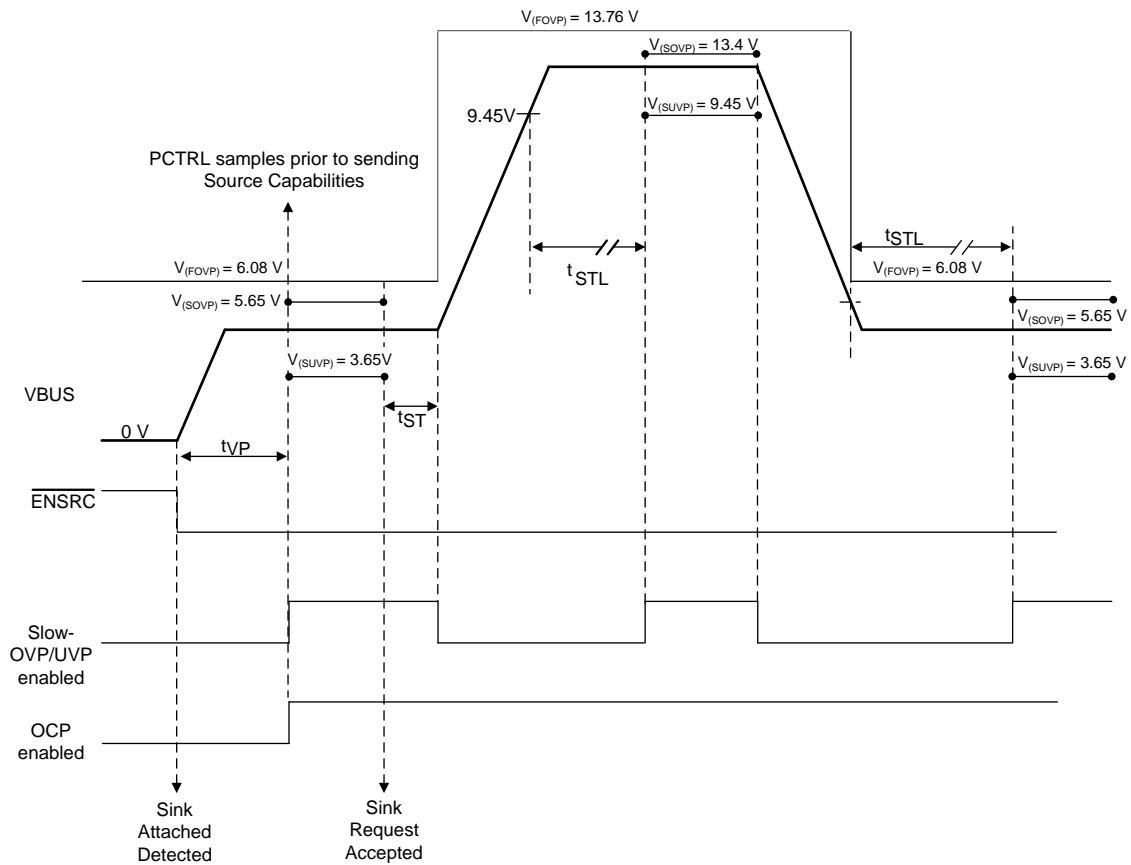

Figure 1. Timing Illustration for t_{VP} , t_{ST} and t_{STL} , After Sink Attachment Negotiation to 12 V Then Back to 5 V. $V_{(SOVP)}$ and $V_{(SUVP)}$ are Disabled Around Voltage Transitions.

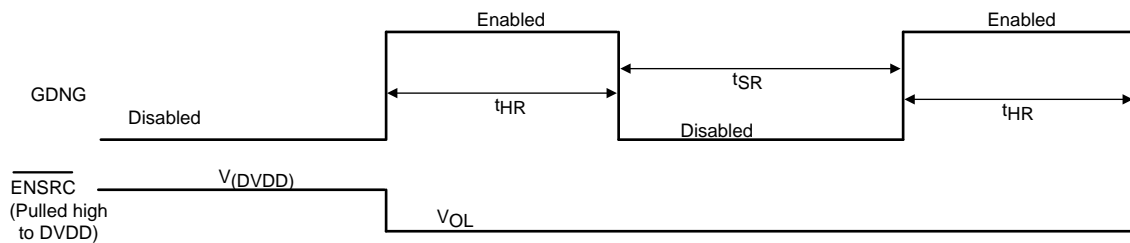

Figure 2. Timing Illustration for t_{HR} and t_{SR} , After Sink Attachment with Persistent $T_J > T_{J1}$

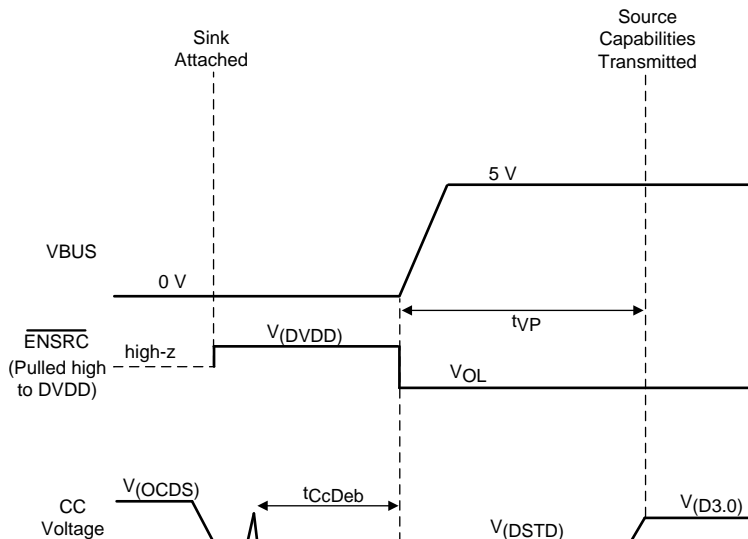

Figure 3. Timing Illustration for t_{CcDeb} and t_{VP} , Under Persistent Fault Condition

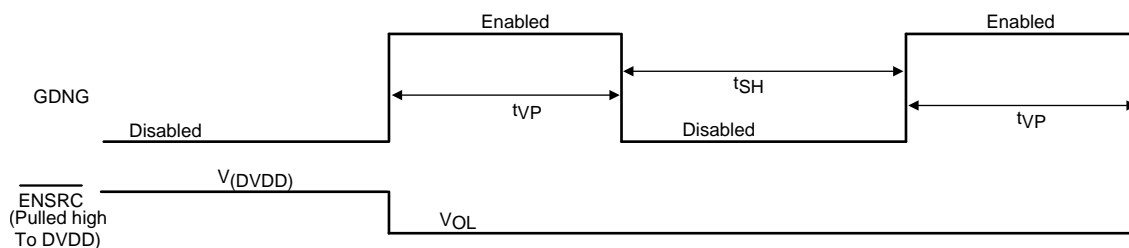

Figure 4. Timing Illustration for t_{SH} and t_{VP} , with VBUS Shorted to Ground

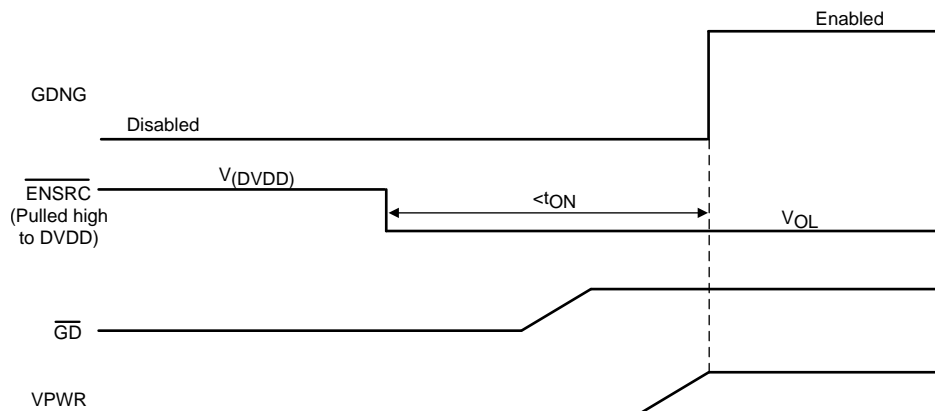

Figure 5. Timing Illustration for t_{ON}

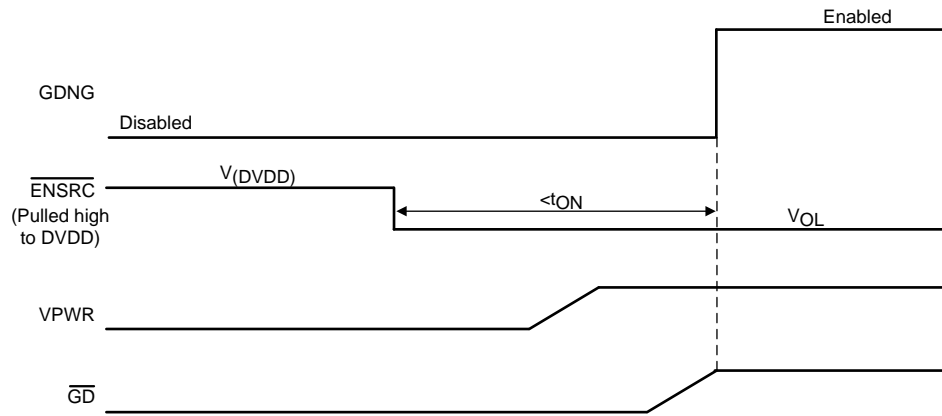

Figure 6. Timing Illustration for t_{ON}

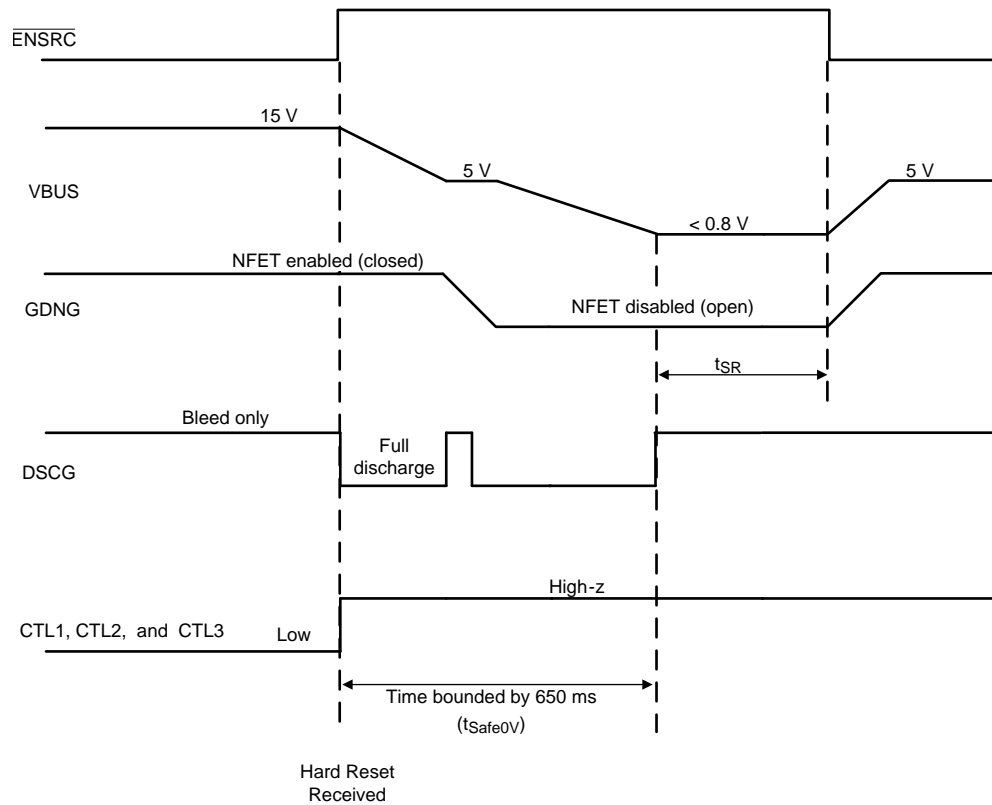

Figure 7. Timing Diagram for \overline{ENSRC} and $GDNG$ After Receiving a Hard Reset

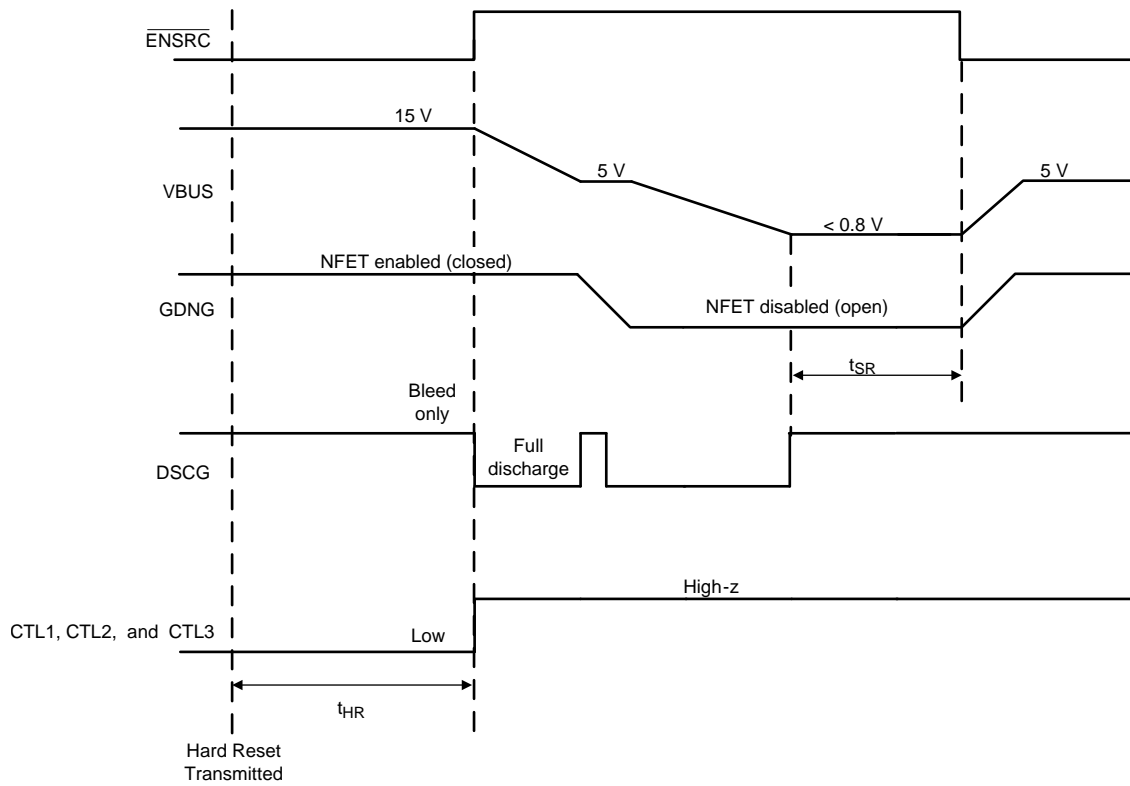
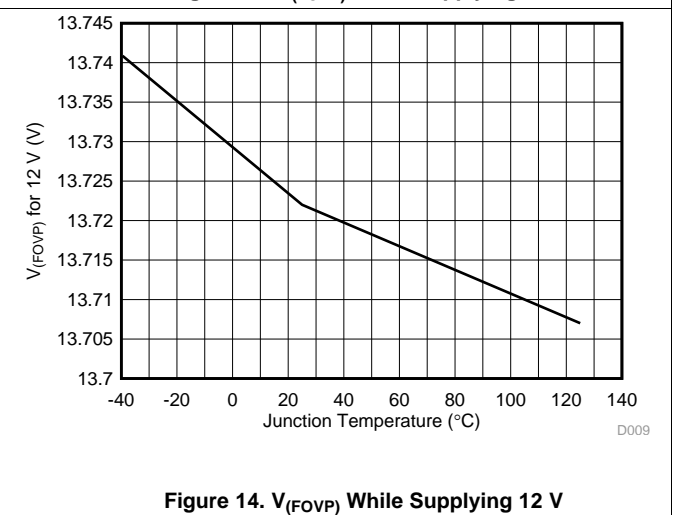
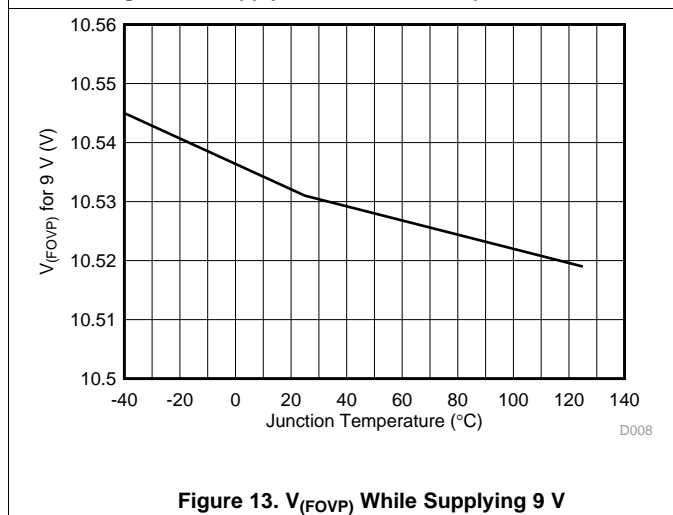
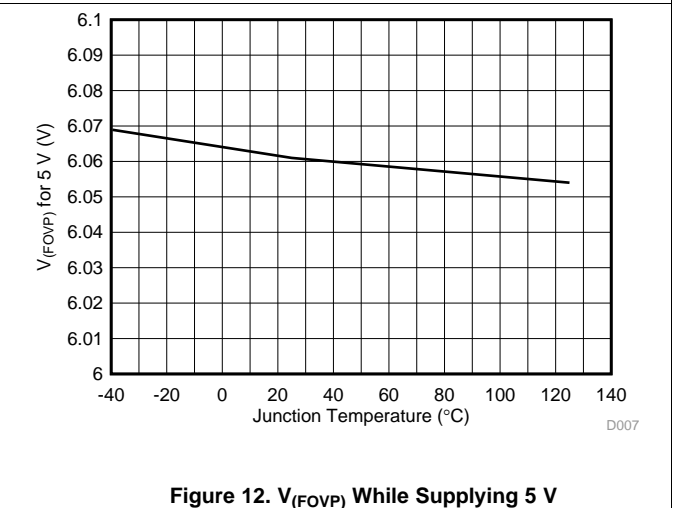
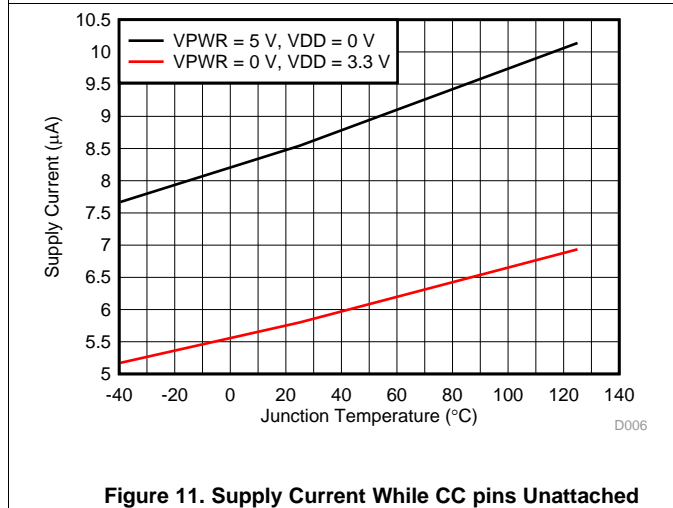
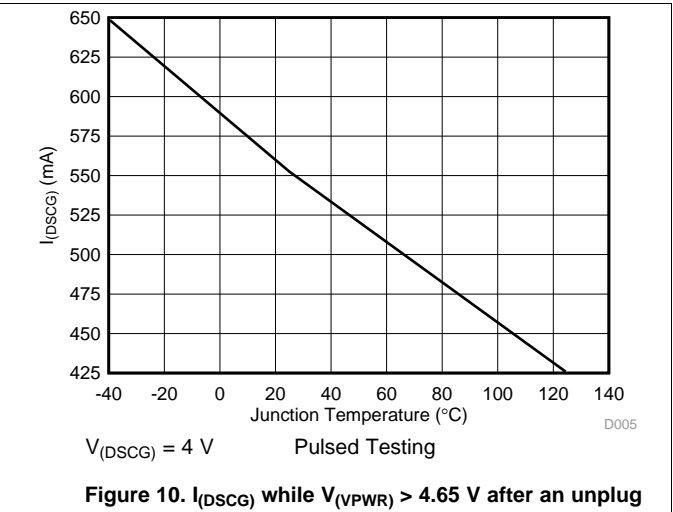
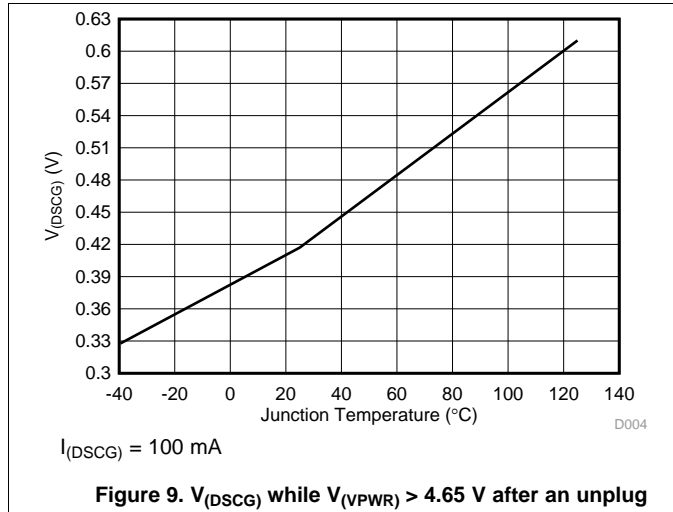

Figure 8. Timing Diagram for $\overline{\text{ENSRC}}$ and GDNG After Transmitting a Hard Reset

7.8 Typical Characteristics



Typical Characteristics (continued)

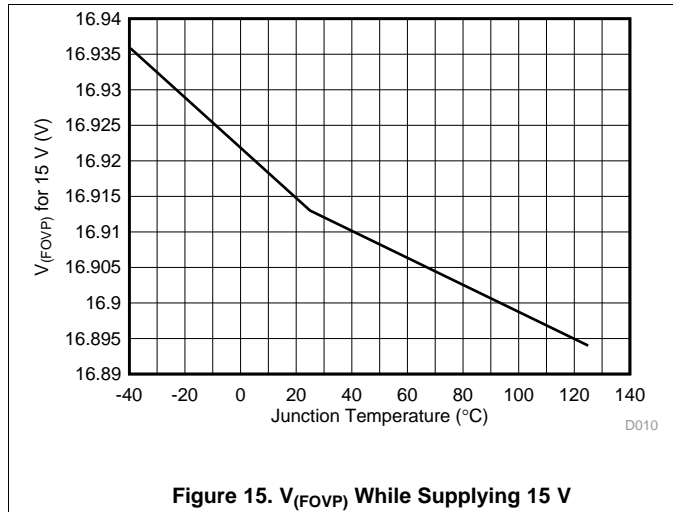

Figure 15. $V_{I(FOVP)}$ While Supplying 15 V

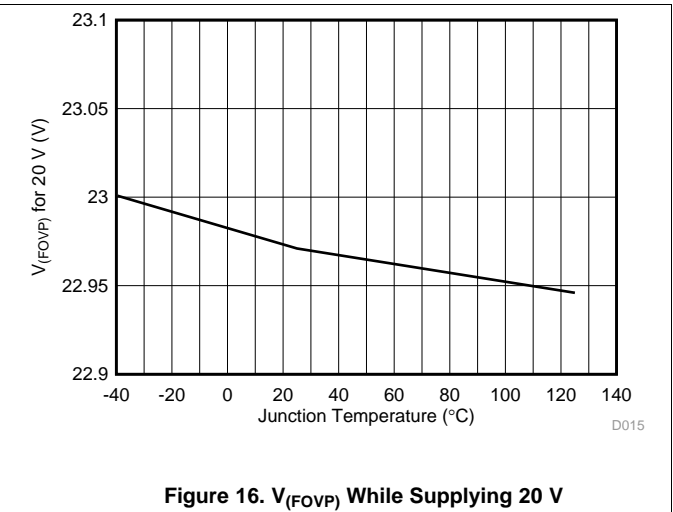

Figure 16. $V_{I(FOVP)}$ While Supplying 20 V

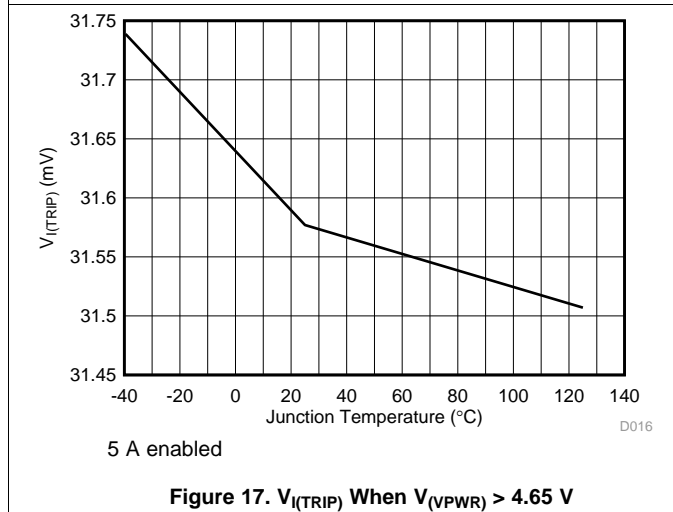

Figure 17. $V_{I(TRIP)}$ When $V_{V(PWR)} > 4.65$ V

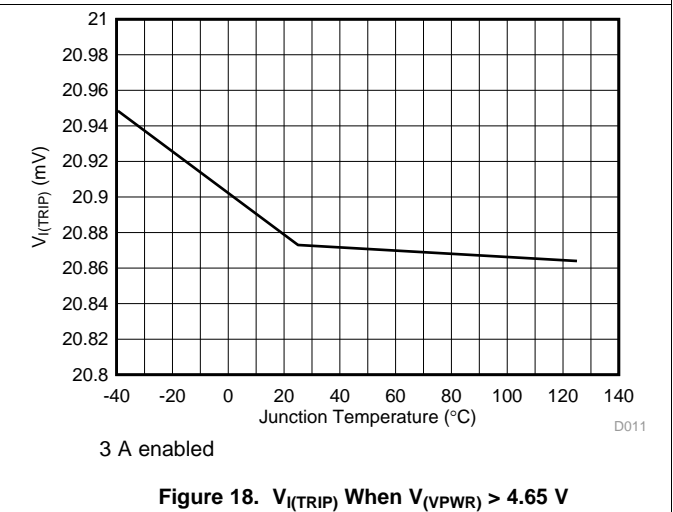

Figure 18. $V_{I(TRIP)}$ When $V_{V(PWR)} > 4.65$ V

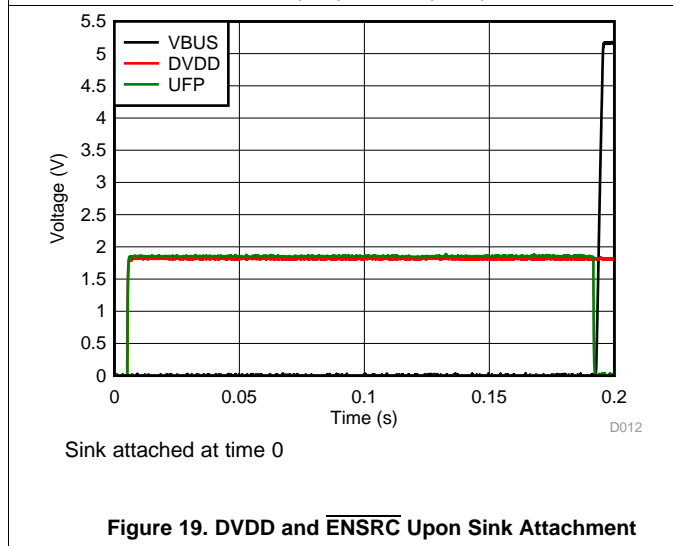

Figure 19. DVDD and \overline{ENSRC} Upon Sink Attachment

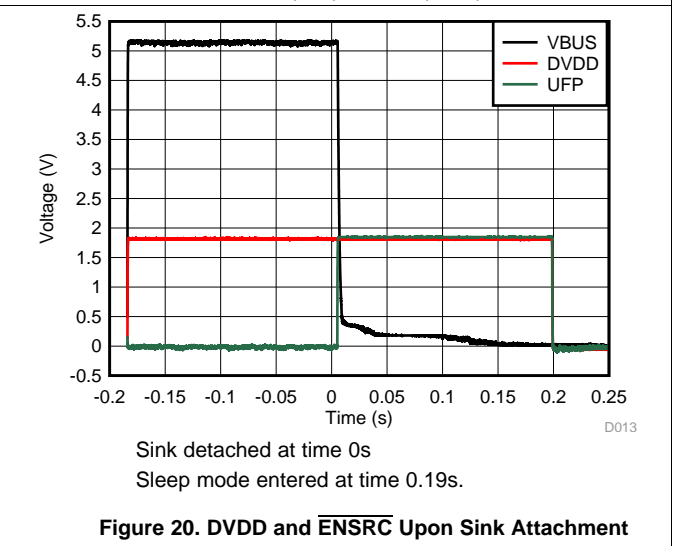

Figure 20. DVDD and \overline{ENSRC} Upon Sink Attachment

8 Detailed Description

8.1 Overview

The TPS25740B and supporting circuits perform the functions required to implement a USB Power Delivery (PD) 2.0 as a provider-only and a USB Type-C revision 1.2 source. It uses its CC pins to detect the attachment of a sinking device or upward facing port (UFP) and to determine which of CC1 or CC2 is connected to the CC wire of the cable. It then communicates over the CC wire in the cable bundle using USB PD to offer a set of voltages and currents. USB PD is a technology that utilizes the ubiquitous USB communications and hardware infrastructure to extend the amount of power available to devices from the 7.5 W range for USB BC1.2 to as high as 100 W in a dock. It is a compatible overlay to USB 2.0 and USB 3.0, coexisting with the existing 5 V powered universe of devices by use of adapter cables. Some basic characteristics of this technology relevant to the device include:

- Increased power achieved by providing higher current and/or higher voltage.
- New 3 A cable and 5 A connector to support greater than the traditional 1.5 A.
 - Cables have controlled voltage drop
- Voltages greater than 5 V are negotiated between PD partners.
 - Standard 5 V is always the default source voltage.
 - Voltage and current provisions are negotiated between PD partners.
- PD partners negotiate over the CC line to avoid conflict with existing signaling (that is, D+, D-)
- Layered communication protocol defined including PHY, Protocol Layer, Policy Engine, and Device Policy Manager all implemented within the device.
- The Type-C connector standard implements pre-powerup signaling to determine:
 - Connector orientation
 - Source 5-V capability
 - Detect through connection of a UFP (upward facing port) to a DFP (downward facing port).
 - Detection of when the connected UFP is disconnected. VBUS is unpowered until a through-connection is present

Figure 21 and Figure 22 show a typical configuration for the device.

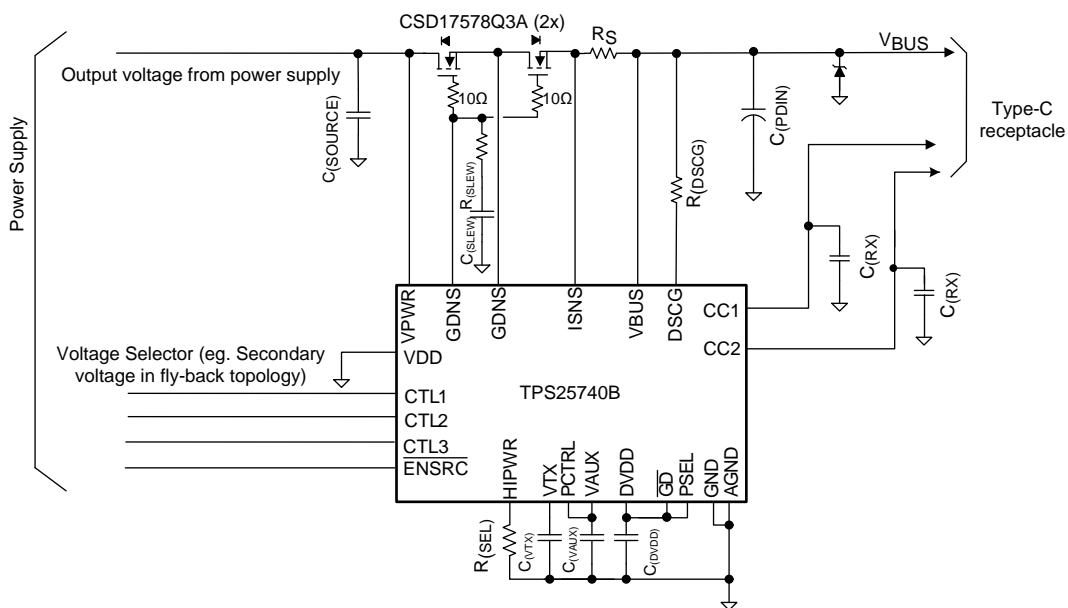

Copyright © 2016, Texas Instruments Incorporated

Figure 21. Schematic 1

Overview (continued)

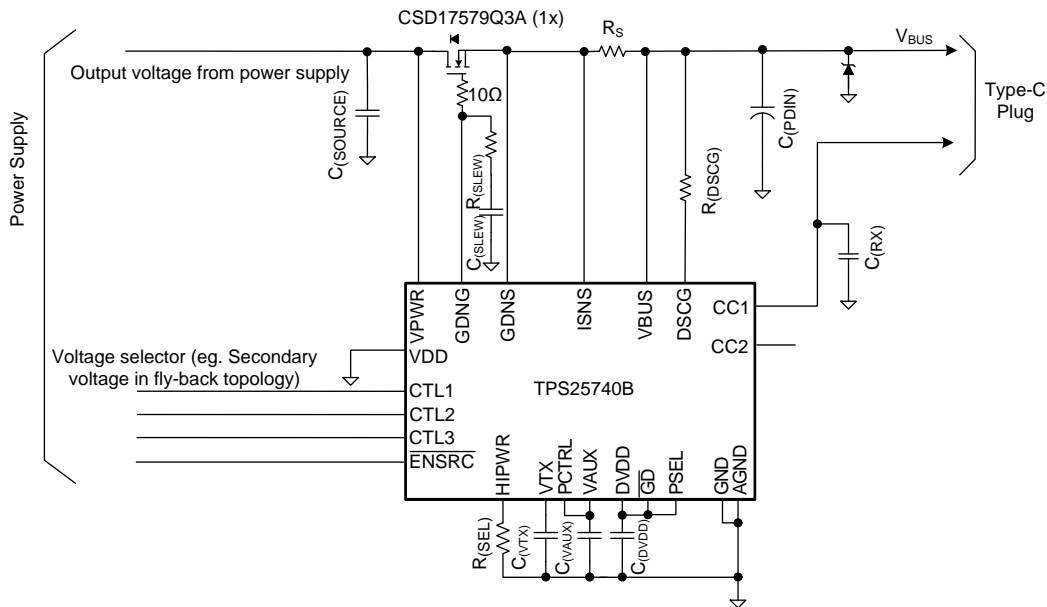

Copyright © 2016, Texas Instruments Incorporated

Figure 22. Schematic 2

8.1.1 VBUS Capacitance

The USB Type-C specification requires that the capacitance on the VBUS pin of an empty receptacle be below 10 μ F. This is to protect legacy USB sources that are not designed to handle the larger inrush capacitance and which may be connected via an A-to-C cable. For applications with USB Type-C receptacles and large bulk capacitance, this means back-to-back blocking FETs are required as shown in Figure 21. However, for applications with a USB Type-C plug (that is, a captive cable) this requirement does not apply since an adaptor cable with a USB Type-C receptacle and a Type-A plug is not defined or allowed by the USB I/F. Figure 22 is a schematic for such applications.

8.1.2 USB Data Communications

The USB Power Delivery specification requires that sources such as the device advertise in the source capabilities messages they transmit whether or not they are in a product that supports USB data communications. The device has this bit hard-coded to 0.

8.2 Functional Block Diagram

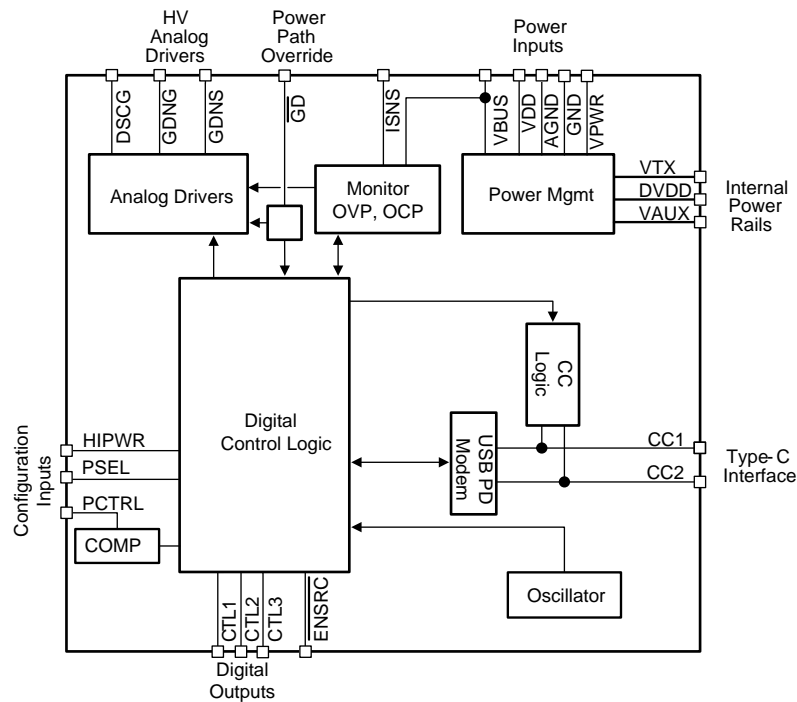

Copyright © 2016, Texas Instruments Incorporated

8.3 Feature Description

This section describes the features associated with each pin for the device.

8.3.1 ENSRC

$\overline{\text{ENSRC}}$ is an open-drain output pin used to indicate whether voltage is being provided to the port. $\overline{\text{ENSRC}}$ goes low when a sink is attached to the port and VBUS is low. A sink attachment is detected when the voltage on one (not both) of the CC pins remains between $V_{(\text{RDSTD})}$ and $V_{(\text{DSTD})}$ for t_{CcDeb} and the voltage on the VBUS pin is below $V_{(\text{VBUS_FTH})}$. After being pulled low, ENSRC remains low until TPS25740B determines that it should remove voltage from the port at which time it goes to high-z. In some applications, the ENSRC pin may be used to disable the power supply instead of using a blocking NFET (See [Using ENSRC to Enable the Power Supply upon Sink Attachment](#)).

8.3.2 USB Type-C CC Logic (CC1, CC2)

The device uses a current source to implement the pull up resistance USB Type-C requires for Sources. While waiting for a valid connection, the device applies a default pullup of $I_{(\text{RPSTD})}$. A sink attachment is detected when the voltage on one (not both) of the CC pins remains between $V_{(\text{RDSTD})}$ and $V_{(\text{DSTD})}$ for t_{CcDeb} and the voltage on the VBUS pin is below $V_{(\text{VBUS_FTH})}$. Then after turning on VBUS and disabling the R_p current source for the CCx pin not connected through the cable, the device applies $I_{(\text{RP3.0})}$ to advertise 3 A to non-PD sinks. Finally, if it is determined that the attached sink is PD-capable, the device applies $I_{(\text{RP1.5})}$. During this sequence if the voltage on the monitored CC pin exceeds the detach threshold then the device removes VBUS and begins watching for a sink attachment again.

The TPS25740B digital logic selects the current source switch as illustrated in [Figure 23](#). The schematic shown is replicated for each CC pin.

Feature Description (continued)

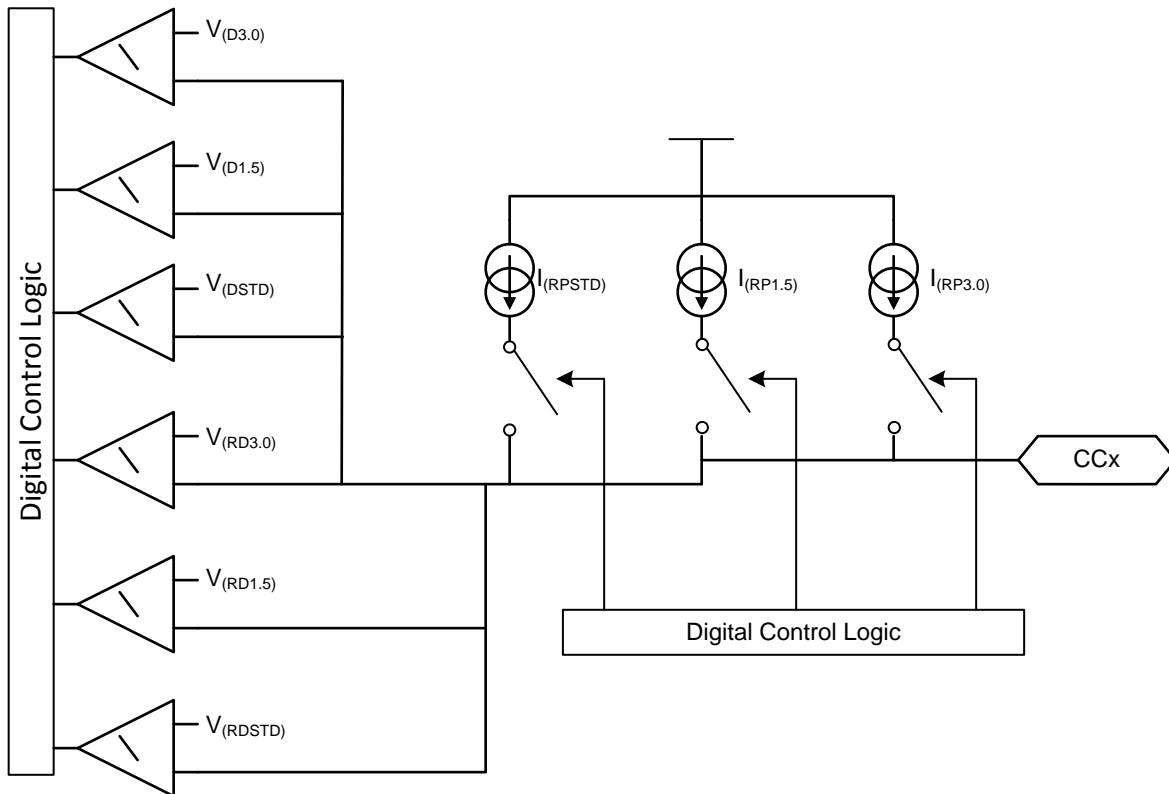

Figure 23. USB Type-C Rp Current Sources and Detection Comparators

If the voltage on both CC pins remains above $V_{(RDSTD)}$ for t_{CcDeb} , then the device goes to the sleep mode. In the sleep mode a less accurate current source is applied and a less accurate comparator watches for attachment (see $V_{(WAKE)}$, and $I_{(DSDFP)}$).

8.3.3 USB PD BMC Transmission (CC1, CC2, VTX)

An example of the BMC signal, specifically the end of the preamble and beginning of start-of-packet (SOP) is shown below. There is always an edge at the end of each bit or unit interval, and ones have an edge half way through the unit interval.

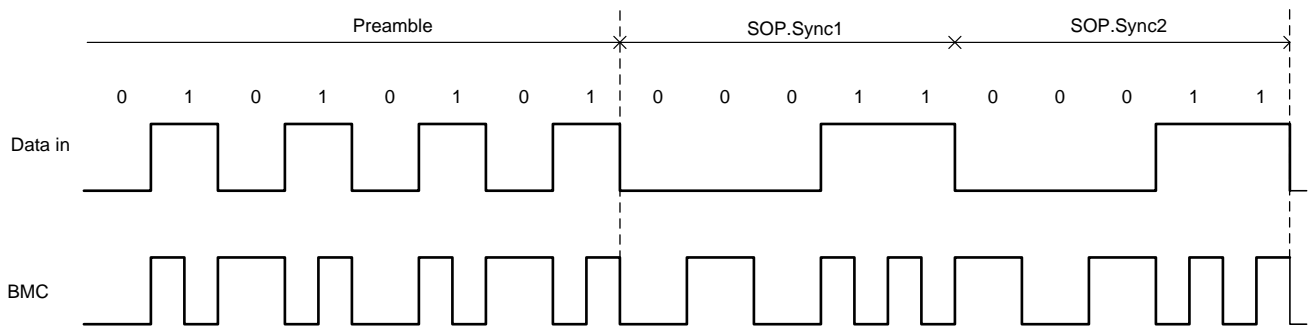

Figure 24. BMC Encoded End of Preamble, Beginning of SOP

Feature Description (continued)

While engaging in USB PD communications, the device is applying $I_{(RP1.5)}$ or $I_{(RP3.0)}$, so the CC line has a DC voltage of 0.918 V or 1.68 V, respectively. When the BMC signal is transmitted on the CC line, the transmitter overrides this DC voltage as shown in Figure 25. The transmitter bias rail (VTX) is internally generated and may not be used for any other purpose in the system. The VTX pin is only high while the TPS25740B is transmitting a USB PD message.

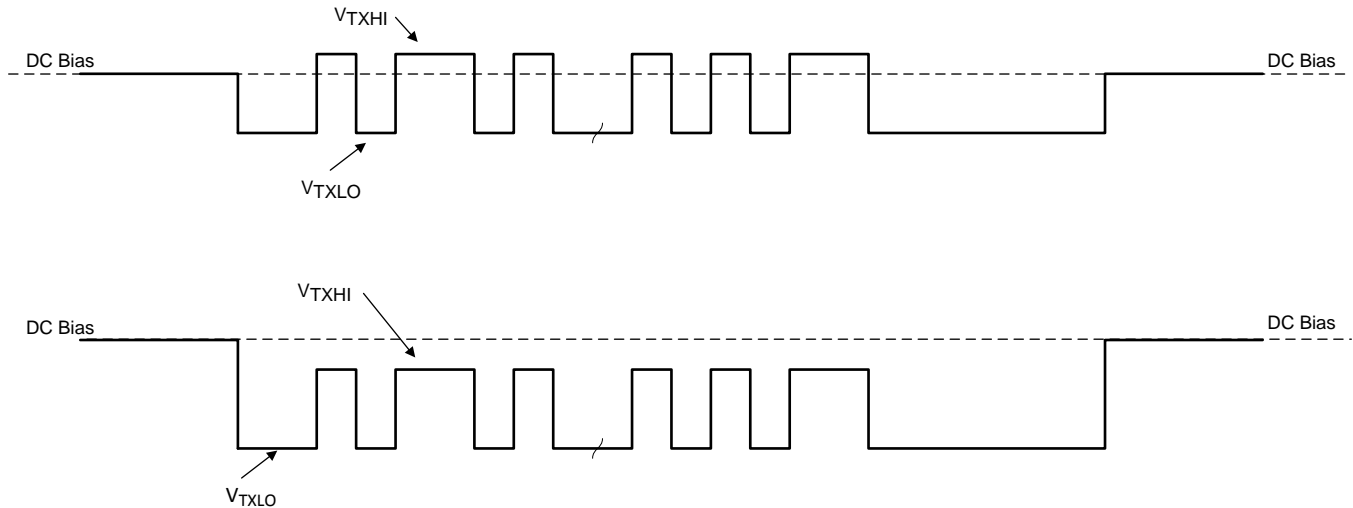
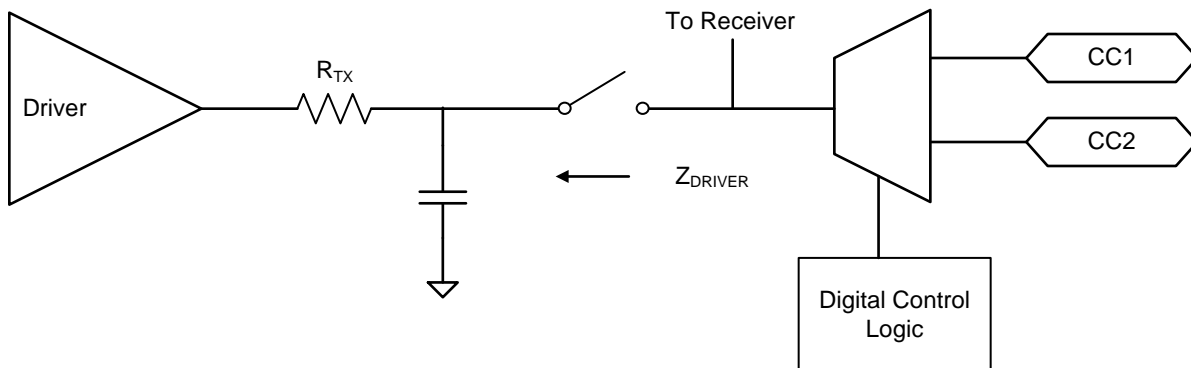

Figure 25. USB PD BMC Transmission on the CC Line

The device transmissions meet the eye diagram USB PD requirements (refer to USB PD in [文档支持](#)) across the recommended temperature range. Figure 26 shows the transmitter schematic.



Copyright © 2016, Texas Instruments Incorporated

Figure 26. USB PD BMC Transmitter Schematic

The transmit eye diagram shown in Figure 28 was measured using the test load shown in Figure 27 with a C_{LOAD} within the allowed range. The total capacitance C_{LOAD} is computed as:

$$C_{LOAD} = C_{(RX)} + C_{CablePlug} \times 2 + C_a + C_{Receiver} \quad (1)$$

Where:

- $200 \text{ pF} < C_{(RX)} < 600 \text{ pF}$
- $C_{CablePlug} < 25 \text{ pF}$
- $C_a < 625 \text{ pF}$
- $200 \text{ pF} < C_{Receiver} < 600 \text{ pF}$

Therefore, $400 \text{ pF} < C_{LOAD} < 1850 \text{ pF}$.

Feature Description (continued)

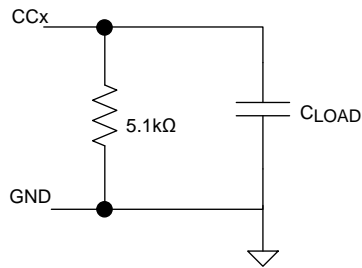

Copyright © 2016, Texas Instruments Incorporated

Figure 27. Test Load for BMC Transmitter

Figure 28 shows the transmit eye diagram for the TPS25740B.

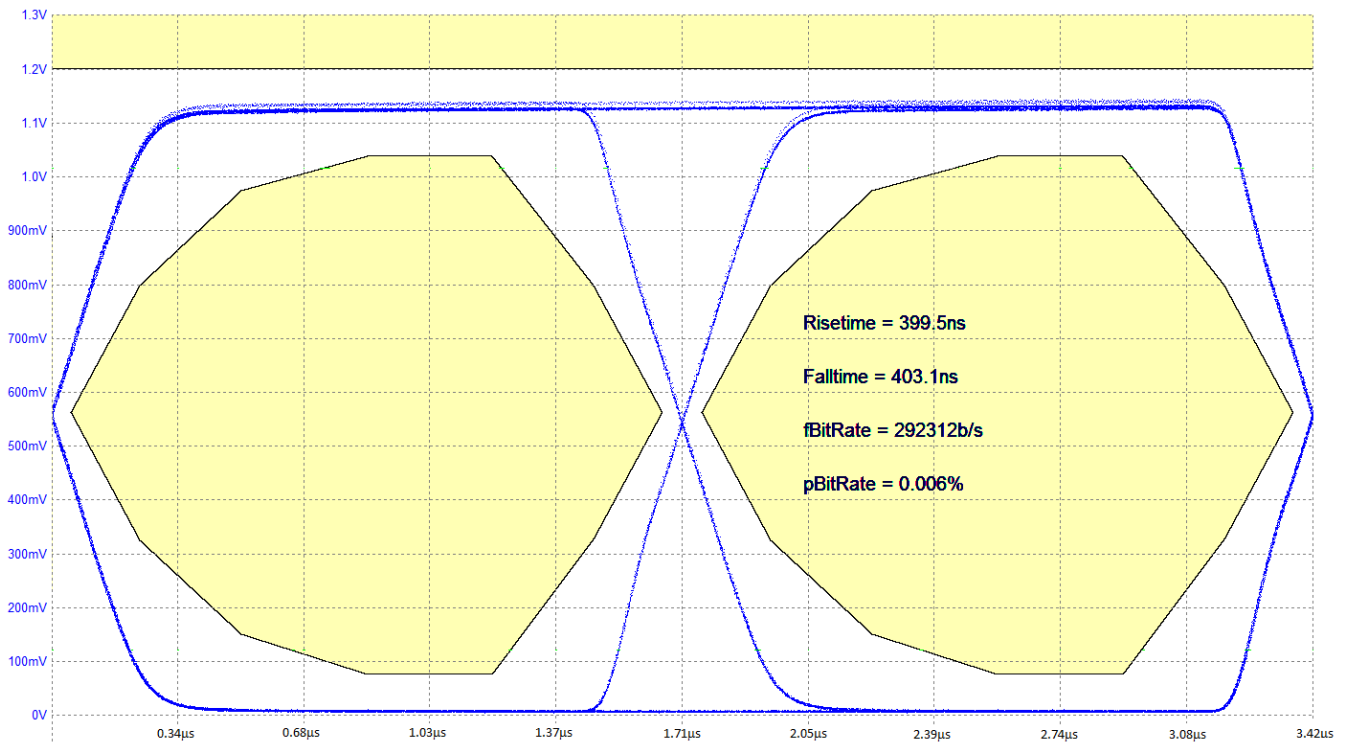

Figure 28. Transmit Eye Diagram (BMC)

Feature Description (continued)

8.3.4 USB PD BMC Reception (CC1, CC2)

The device BMC receiver follows the USB PD requirements (refer to USB PD in [文档支持](#)) using the schematic shown in [Figure 29](#).

The device low-pass filter design and receiver threshold design allows it to reject interference that may couple onto the CC line from a noisy VBUS power supply or any other source (refer to $V_{(INT)}$).

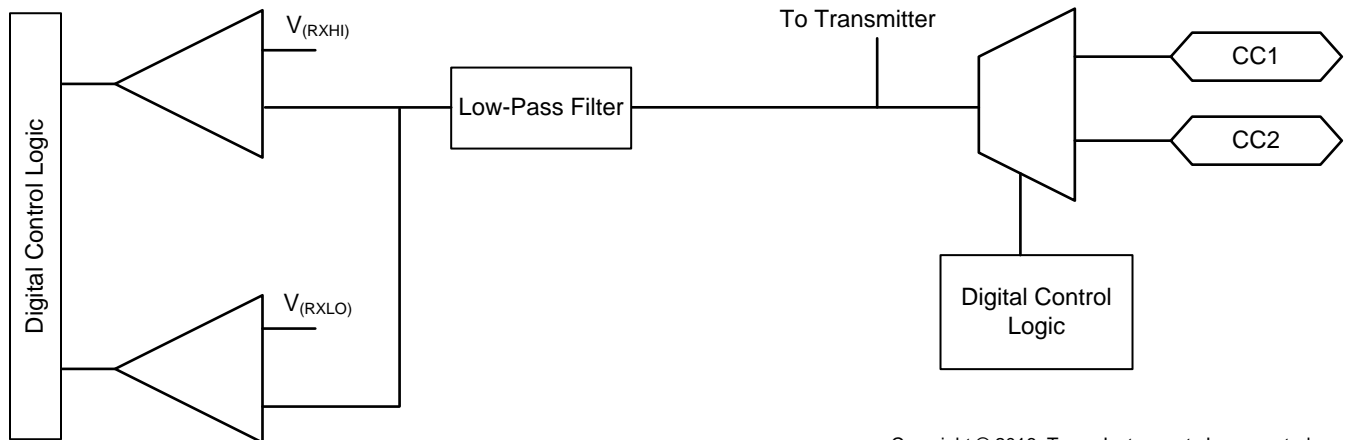

Copyright © 2016, Texas Instruments Incorporated

Figure 29. USB PD BMC Receiver Schematic

8.3.5 Discharging (DSCG, VPWR)

The DSCG pin allows for two different pull-downs that are used to apply different discharging strengths. In addition, the VPWR pin is used to apply a load to discharge the power supply bulk capacitance.

If too much power is dissipated by the device (that is, the T_{J1} temperature is exceeded) an OTSD occurs that disables the discharge FET; therefore, an external resistor is recommended in series with the DSCG pin to absorb most of the dissipated power. The external resistor $R_{(DSCG)}$ should be chosen such that the current sunk by the DSCG pin does not exceed $I_{(DSCGT)}$.

The VPWR pin should always be connected to the supply side (as opposed to the connector side) of the power-path switch ([Figure 30](#) shows one example). This pin is monitored before enabling the GDNG gate driver to apply the voltage to the VBUS pin of the connector.

From sink attachment, and while the device has not finalized a USB PD contract, the device applies $R_{(DSCGB)}$.

Also from sink attachment, and while the device has not finalized a USB PD contract, the device draws $I_{(SUPP)}$ through the VPWR pin even if VDD is above its UVLO. This helps to discharge the power supply source.

Feature Description (continued)

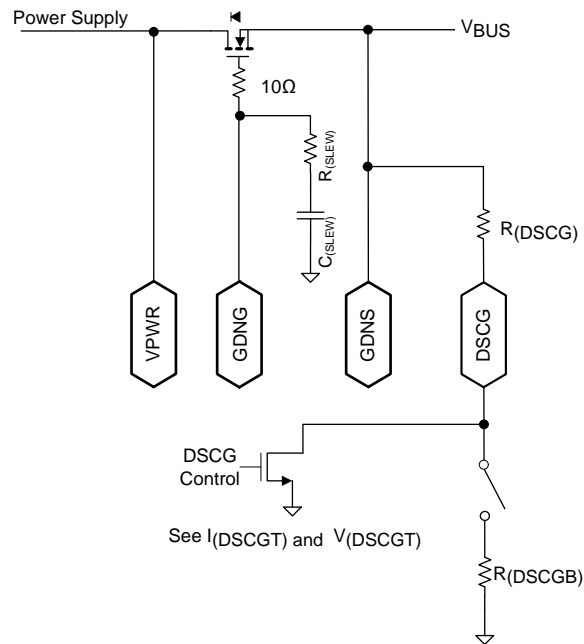

Copyright © 2016, Texas Instruments Incorporated

Figure 30. Discharge Schematic

The discharge procedure used in the device is intended to allow the DSCG pin to help pull the power supply down from high voltage, and then also pull VBUS at the connector down to the required level (refer to USB PD in [文档支持](#)).

8.3.5.1 Discharging after a Fault (VPWR)

There are two types of faults that cause the TPS25740B to begin a full discharge of VBUS: Slow-shutdown faults and fast-shutdown faults. When a slow-shutdown fault occurs, the device does not disable GDNG until after VBUS is measured below $V_{(SOVP)}$ for a 5V contract. When a fast-shutdown fault occurs, the device disables GDNG immediately and then discharges the connector side of the power-path. In both cases, the bleed discharge is applied to the DSCG pin and $I_{(SUPP)}$ is drawn from the VPWR

Slow-shutdown faults that do not include transmitting a hard reset:

- Receiving a Hard Reset signal ($25\text{ ms} < t_{\text{ShutdownDelay}} < 35\text{ ms}$)
- Cable is unplugged ($t_{\text{ShutdownDelay}} < 20\text{ }\mu\text{s}$)

Slow-shutdown faults that include transmitting hard reset ($25\text{ ms} < t_{\text{ShutdownDelay}} < 35\text{ ms}$)

- T_J exceeds T_{J1} (an overtemperature event)
- Low voltage alarm occurring outside of a voltage transition
- High voltage alarm occurring outside of a voltage transition (but not high enough to cause OVP)
- Receiving an unexpected PD message during a voltage transition
- Failure of power supply to transition voltages within required time of 600 ms ($t_{\text{PSTransition}}$ (refer to USB PD in [文档支持](#)).
- A Soft Reset USB PD message is not acknowledged or Accepted (refer to USB PD in [文档支持](#)).
- A Request USB PD message is not received in the required time (refer to USB PD in [文档支持](#)).
- Failure to discharge down to 0.725 V after a fault of any kind.

Feature Description (continued)

Fast-shutdown faults (hard reset always sent):

- Fast OVP event occurring at any time.
- OCP event occurring at any time starting from the transmission of the first USB PD message.
 - VBUS falling below $V_{(VBUS_FTH)}$ is treated as an OCP event.
- \overline{GD} falling edge

The DSCG pin is used to discharge the supply line after a slow-shutdown fault occurs. Figure 31 illustrates the signals involved. Depending on the specific slow-shutdown fault the time $t_{ShutdownDelay}$ in Figure 31 is different as indicated in the list above. If the slow-shutdown fault triggers a hard reset, it is sent at the beginning of the $t_{ShutdownDelay}$ period. However, the device behavior after the time $t_{ShutdownDelay}$ is the same for all slow-shutdown faults. After the $t_{ShutdownDelay}$ period, the device sets CTL1, CTL2, and CTL3 to select 5 V from the power supply and puts the DSCG pin into its ON state (Full Discharge). This discharging continues until the voltage on the VBUS pin reaches $V_{(SOVP)}$ for a 5-V contract. The device then disables GDNG and again puts the DSCG pin into its ON state. This discharging state lasts until the voltage on VBUS reaches 0.725 V (nominal). If the discharge does not complete within 650 ms, then the device sends a Hard Reset signal and the process repeats. In Figure 31, the times labeled as $t_{15 \rightarrow 5}$ and $t_{5 \rightarrow 0}$ can vary, they depend on the size of the capacitance to be discharged and the size of the external resistor between the DSCG pin and VBUS. The time labeled as t_s is a function of how quickly the NFET opens.

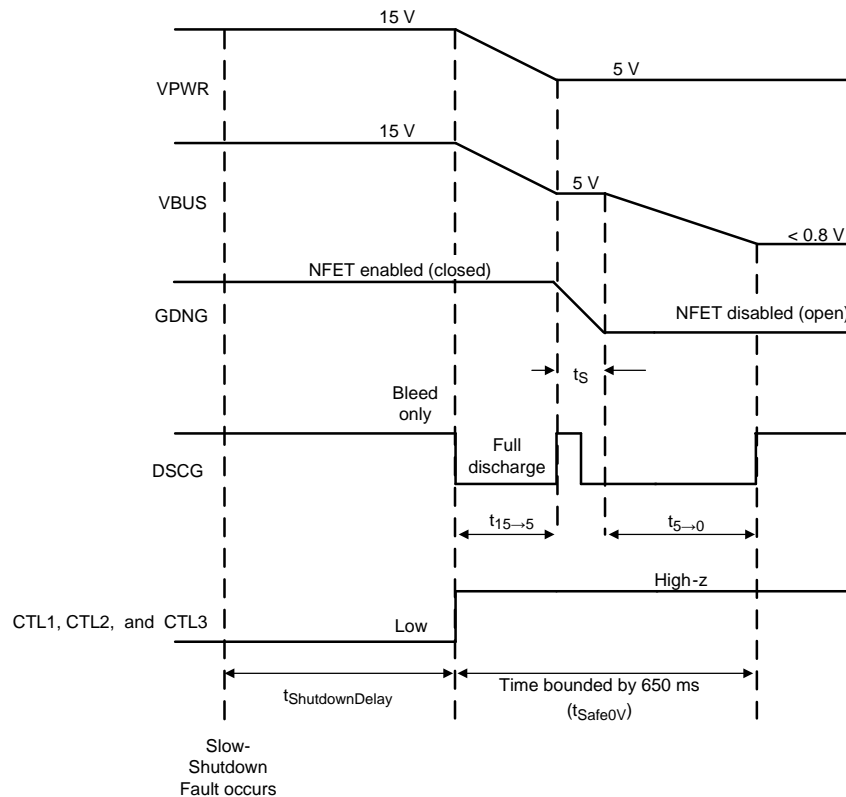

Figure 31. Illustration of Slow-Shutdown VBUS Discharge

Figure 32 illustrates a similar discharge procedure for fast-shutdown faults. The main difference from Figure 31 is that the NFET is opened immediately. It is assumed for the purposes of this illustration that the power supply output capacitance (that is, $C_{(SOURCE)}$ in the reference schematics shown in Figure 21 and Figure 22) is not discharged by the power supply itself, but the VPWR pin is bleeding current from that capacitance. The VPWR pin then draws $I_{(SUPP)}$ after GDNG disables the external NFET. So, as shown in the figure, the VPWR voltage discharges slowly, while the VBUS pin is discharged once the full discharge is enabled. If the voltage on the VPWR pin takes longer than $t_{15 \rightarrow 5} + t_{5 \rightarrow 0} + 0.765s$ to discharge below $V_{(FOVP)}$, then it causes an OVP event and the process repeats.

Feature Description (continued)

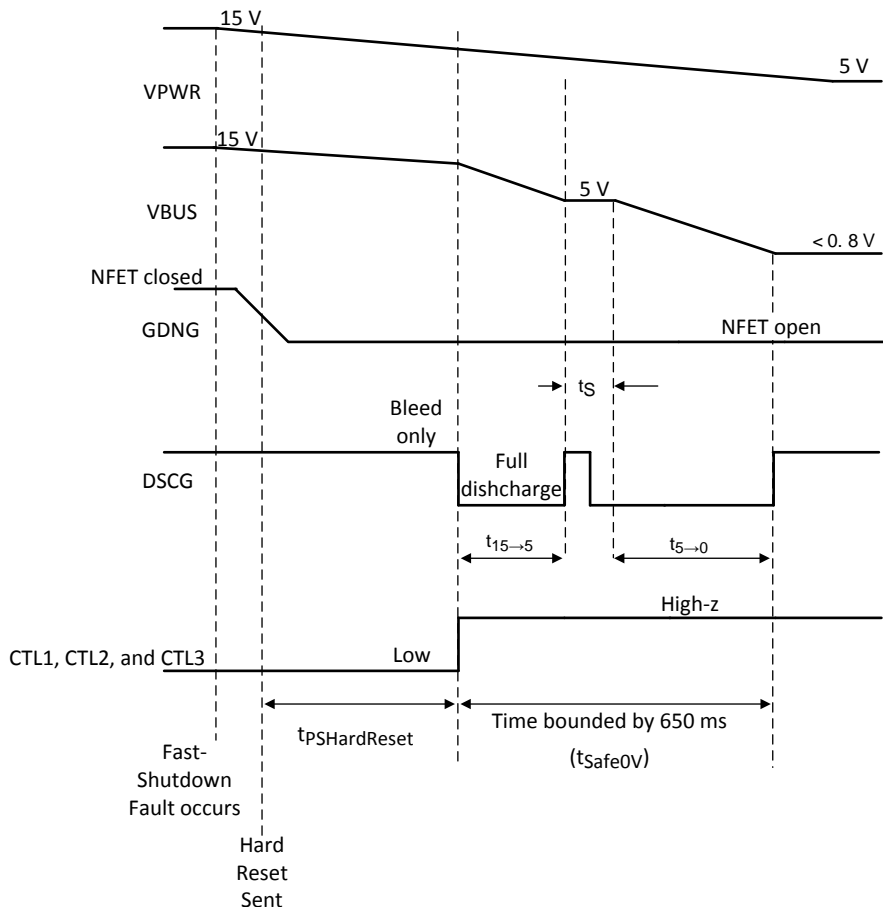

Figure 32. Illustration of Fast-Shutdown Discharge

If the discharge does not complete successfully it is treated as a slow-shutdown fault, and the device repeats the discharge procedure until it does complete successfully. Once the discharge completes successfully as described above (that is, VBUS on connector is below 0.725 V), the device waits for 0.765 s (nominal) before trying to source VBUS again.

8.3.6 Configuring Voltage Capabilities (HIPWR)

The voltages advertised to USB PD-capable sinks can be configured to one of two different sets. Note that changing the state of the PCTRL pin forces capabilities to be re-transmitted. The device reads the HIPWR pin after a reset and latches the result.

Table 1. Voltage Programming (TPS25740B)

HIPWR PIN	VOLTAGES ADVERTISED via USB PD [V]
Connected to DVDD or GND directly	5, 9, 15, 20
Connected to DVDD or GND via R _(SEL)	5, 9, 12, 15

8.3.7 Configuring Power Capabilities (PSEL, PCTRL, HIPWR)

The power advertised to non-PD Type-C Sinks is always 15 W. However, the device only advertises Type-C default current until it debounces the Sink attachment for t_{CcDeb} and the VBUS voltage has been given t_{VP} to stabilize.

The device does not communicate with the cable to determine its capabilities. Therefore, unless the device is in a system with a captive cable able to support 5 A, the HIPWR pin should be used to limit the advertised current to 3 A.

PCTRL is an input pin used to control how much of the maximum allowed power the port will advertise. This pin may be changed dynamically in the system and the device automatically updates any existing USB PD contract. If the PCTRL pin is pulled below $V_{(PCTRL_TH)}$, then the source capabilities offers half of the maximum power specified by the PSEL pin.

The devices read the PSEL and HIPWR pins after a reset and latches the result, but the PCTRL pin is read dynamically by the device and if its state changes new capabilities are calculated and then transmitted.

While USB PD allows advertising a power of 100 W, UL certification for Class 2 power units (UL 1310) requires the maximum power remain below 100 W. The device only advertises up to 4.65 A for a 20-V contract, this allows the V_{BUS} overshoot to reach 21.5 V as allowed by USB PD while remaining within the UL certification limits. Therefore, the device allows delivering 100 W of power without adding additional voltage tolerance constraints on the power supply.

The PSEL pin offers four possible maximum power settings, but the devices can actually advertise more power settings depending upon the state of the HIPWR and PCTRL pins. [Table 2](#) summarizes the four maximum power settings that are available via PSEL, again note this is not necessarily the maximum power that is advertised.

Table 2. PSEL Configurations

MAXIMUM POWER (PSEL) [W]	PSEL
$P_{(SEL)} = 36$	Direct to GND
$P_{(SEL)} = 45$	DVDD via $R_{(SEL)}$
$P_{(SEL)} = 65$	GND via $R_{(SEL)}$
$P_{(SEL)} = 93$	Direct to DVDD

[Equation 2](#) provides a quick reference which applies to device to see how the HIPWR, PSEL and PCTRL pins affect what current is advertised with each voltage in the source capabilities message:

$$I_x = \min\left(\frac{P_{max}}{V_{max}}, I_{max}\right) \quad (2)$$

Where:

- For a voltage V_x , the advertised current is I_x
- If the PCTRL pin is low, then $P_{max} = P_{(SEL)} / 2$
- If the PCTRL pin is high, then $P_{max} = P_{(SEL)}$.
- If the HIPWR pin is pulled high, then $I_{max} = 3$ A.
- If the HIPWR pin is pulled low, then $I_{max} = 5$ A.

[Table 3](#) provides a comprehensive list of the currents and voltages that are advertised for each voltage.

Table 3. Maximum Current Advertised in the Power Data Object for a Given Voltage

PSEL	VOLTAGE [V]	HIPWR	MAXIMUM CURRENT PCTRL = LOW [A]	MAXIMUM CURRENT PCTRL = HIGH [A]
Direct to GND	5	Max = 3 A DVDD through R _(SEL) or Direct to DVDD	3	3
DVDD via R _(SEL)			3	3
GND via R _(SEL)			3	3
Direct to DVDD			3	3
Direct to GND	9		2	3
DVDD via R _(SEL)			2.5	3
GND via R _(SEL)			3	3
Direct to DVDD			3	3
Direct to GND	12		1.5	3
DVDD via R _(SEL)			1.87	3
GND via R _(SEL)			2.7	3
Direct to DVDD			3	3
Direct to GND	15		1.2	2.4
100kΩ to DVDD			1.5	3
100kΩ to GND			2.17	3
Direct to DVDD			3	3
Direct to GND	20		0.9	1.8
DVDD via R _(SEL)			1.12	2.24
GND via R _(SEL)			1.62	3
Direct to DVDD			2.32	3
Direct to GND	5	Max = 5 A GND through R _(SEL) or Direct to GND	3.6	5
DVDD via R _(SEL)			4.5	5
GND via R _(SEL)			5	5
Direct to DVDD			5	5
Direct to GND	9		2	4
DVDD via R _(SEL)			2.5	5
GND via R _(SEL)			3.61	5
Direct to DVDD			5	5
Direct to GND	12		1.5	3
DVDD via R _(SEL)			1.87	3.74
GND via R _(SEL)			2.7	5
Direct to DVDD			4.16	5
Direct to GND	15		1.2	2.4
100kΩ to DVDD			1.5	3
100kΩ to GND			2.17	4.33
Direct to DVDD			3.1	5
Direct to GND	20		0.9	1.8
DVDD via R _(SEL)			1.12	2.24
GND via R _(SEL)			1.62	3.24
Direct to DVDD			2.32	4.64

8.3.8 Gate Driver (GDNG, GDNS)

The GDNG and GDNS pins may control a single NFET or back-to-back NFETs in a common-source configuration. The GDNS is used to sense the voltage so that the voltage differential between the pins is maintained.

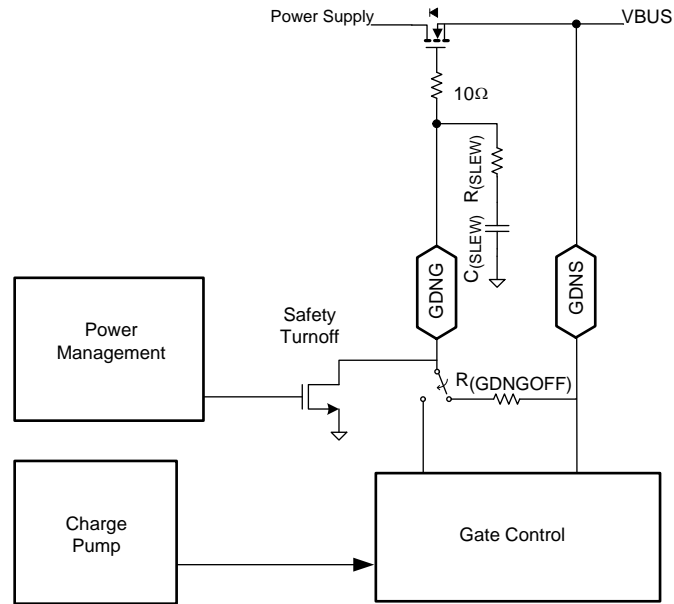

Copyright © 2016, Texas Instruments Incorporated

Figure 33. GDNG/GDNS Gate Control

8.3.9 Fault Monitoring and Protection

8.3.9.1 Over/Under Voltage (VBUS)

The TPS25740B uses the VBUS pin to monitor for overvoltage or undervoltage conditions and implement the fast-OVP, slow-OVP and slow-UVP features.

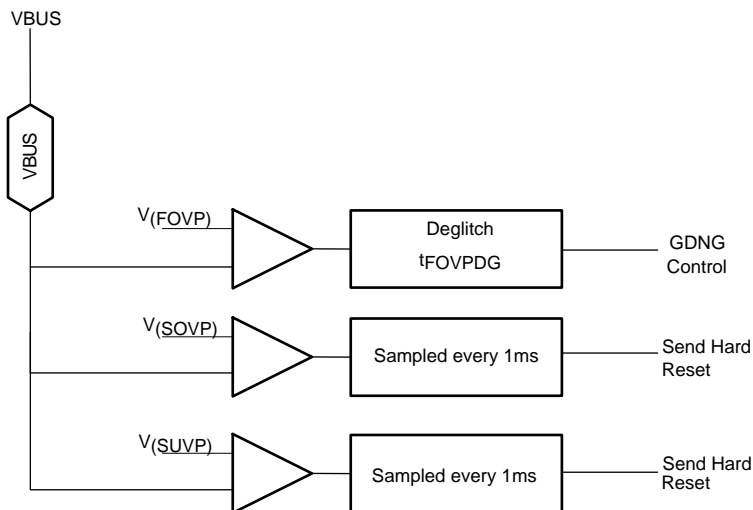

Copyright © 2016, Texas Instruments Incorporated

Figure 34. Voltage Monitoring Circuits

If an over-voltage condition is sensed by the Fast OVP mechanism, GDNG is disabled within $t_{FOVP} + t_{FOVPDG}$, then a Hard Reset is transmitted and the VBUS discharge sequence is started. At power up the voltage trip point is set to $V_{(FOVP)}$ (5 V contract). When a contract is negotiated the trip point is set to the corresponding $V_{(FOVP)}$ value.

The devices employ another slow over-voltage protection mechanism as well that sends the Hard Reset before disabling the external NFET. It catches many OV events before the Fast OVP mechanism. During intentional positive voltage transitions, this mechanism is disabled (see Figure 1). However, t_{VP} after the external NFET has been enabled, if the voltage on the VBUS pin exceeds $V_{(SOVP)}$ then a Hard Reset is transmitted to the Sink and the VBUS discharge sequence is started.

The devices employ a slow under-voltage protection mechanism as well that sends the Hard Reset before disabling GDNG. During intentional negative voltage transitions, this mechanism is disabled (see Figure 1). However, t_{VP} after the external NFET has been enabled if the voltage on the VBUS pin falls below $V_{(SUVP)}$, then a Hard Reset is transmitted to the Sink and the VBUS discharge sequence is started.

8.3.9.2 Over-Current Protection (ISNS, VBUS)

OCP protection is enabled t_{VP} after the voltage on the VBUS pin has exceeded $V_{(VBUS_RTH)}$. Prior to OCP being enabled, the GD pin can be used to protect against a short.

The OCP protection circuit monitors the differential voltage across an external sense resistor to detect when the current outflow exceeds $V_{I(TRIP)}$ which in turn activates an over-current circuit breaker and disables the GDNG / GDNS gate driver. Once the OCP is enabled, if the voltage on the VBUS pin falls below $V_{(VBUS_FTH)}$ then that is also treated like an OCP event.

Following the recommended implementation of a 5-mΩ sense resistor, when the device is configured to deliver 3 A (via HIPWR pin), the OCP threshold lies between 3.8 A and 4.5 A. When configured to deliver 5 A (via HIPWR pin), the OCP threshold lies between 5.8 A and 6.8 A. The resistance of the sense resistor may be tuned to adjust the current that causes $V_{I(TRIP)}$ to be exceeded.

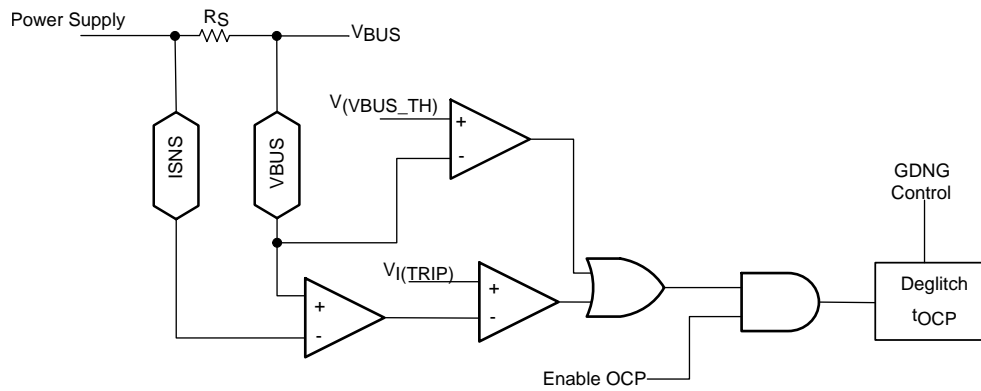

Copyright © 2016, Texas Instruments Incorporated

Figure 35. Overcurrent Protection Circuit, (ISNS, VBUS)

8.3.9.3 System Fault Input ($\overline{\text{GD}}$, VPWR)

The gate-driver disable pin provides a method of overriding the internal control of GDNG and GDNS. A falling edge on $\overline{\text{GD}}$ disables the gate driver within t_{GDoff} . If $\overline{\text{GD}}$ is held low after a sink is attached for 600 ms then a hard reset will be generated and the device sends a hard reset and go through its startup process again.

The $\overline{\text{GD}}$ input can be controlled by a voltage or current source. An internal voltage clamp is provided to limit the input voltage in current source applications. The clamp can safely conduct up to 80 μA and will remain high impedance up to 6.5 V before clamping.

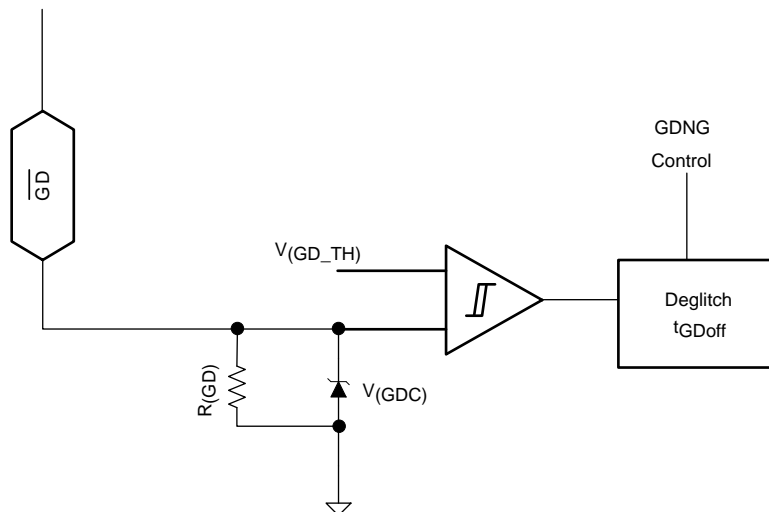

Copyright © 2016, Texas Instruments Incorporated

Figure 36. Overcurrent Protection Circuit, ($\overline{\text{GD}}$)

If the VPWR pin remains below its falling UVLO threshold ($V_{\text{VPWR_TH}}$) for more than 600 ms after a sink is attached then the devices consider it a fault and will not enable GDNG. If the VPWR pin is between the rising and falling UVLO threshold, the device may enable GDNG and proceed with normal operations. However, after GDNG is enabled, if the VBUS pin does not rise above its UVLO within 190 ms the devices consider it a fast-shutdown fault and disables GDNG. Therefore, in order to ensure USB Type-C compliance and normal operation, the VPWR pin must be above its rising UVLO threshold ($V_{\text{VPWR_TH}}$) within 275 ms of when $\overline{\text{ENSRC}}$ is pulled low and the VBUS pin must be above $V_{\text{VBUS_RTH}}$ within 190 ms of GDNG being enabled.

8.3.10 Voltage Control (CTL1, CTL2, CTL3)

CTL1, CTL2, and CTL3 are open-drain output pins used to control an external power supply as summarized in Table 4. Depending upon the voltage requested by the sink, the device sets the CTL pins accordingly. No current flows into the pin in its high-z state.

Table 4. States of CTL1, CTL2, and CTL3 as a Function of Target Voltage on VBUS (TPS25740B)

VOLTAGE CONTAINED in PDO REQUESTED by UFP	CTL3 STATE	CTL2 STATE	CTL1 STATE
5 V	High-z	High-z	High-z
9 V	High-z	Low	High-z
12 V (if 12 V enabled by HIPWR pin) 15 V (if 20 V enabled by HIPWR pin)	High-z	Low	Low
15 V (if 12V enabled by HIPWR pin) 20 V (if 20 V enabled by HIPWR pin)	Low	Low	Low

8.3.11 Sink Attachment Indicator (DVDD)

DVDD is a power supply pin that is high-z until a sink or debug accessory or audio accessory is attached, in which case it is pulled high. Therefore, it can be used as a sink attachment indicator that is active high.

8.3.12 Power Supplies (VAUX, VDD, VPWR, DVDD)

The VAUX pin is the output of a linear regulator and the input supply for internal power management circuitry. The VAUX regulator draws power from VDD after establishing a USB PD contract unless it is not available in which case it draws from VPWR. Changes in supply voltages will result in seamless switching between supplies.

If there is a load on the DVDD pin, that current will be drawn from the VPWR pin unless the device has stabilized into a USB PD contract or VPWR is below its UVLO.

Connect VAUX to GND via the recommended bypass capacitor. Do not connect any external load that draws more than $I_{(VAUXEXT)}$. Locate the bypass capacitor close to the pin and provide a low impedance ground connection from the capacitor to the ground plane.

VDD should either be grounded or be fed by a low impedance path and have input bypass capacitance. Locate the bypass capacitors close to the VDD and VPWR pins and provide a low impedance ground connection from the capacitor to the ground plane.

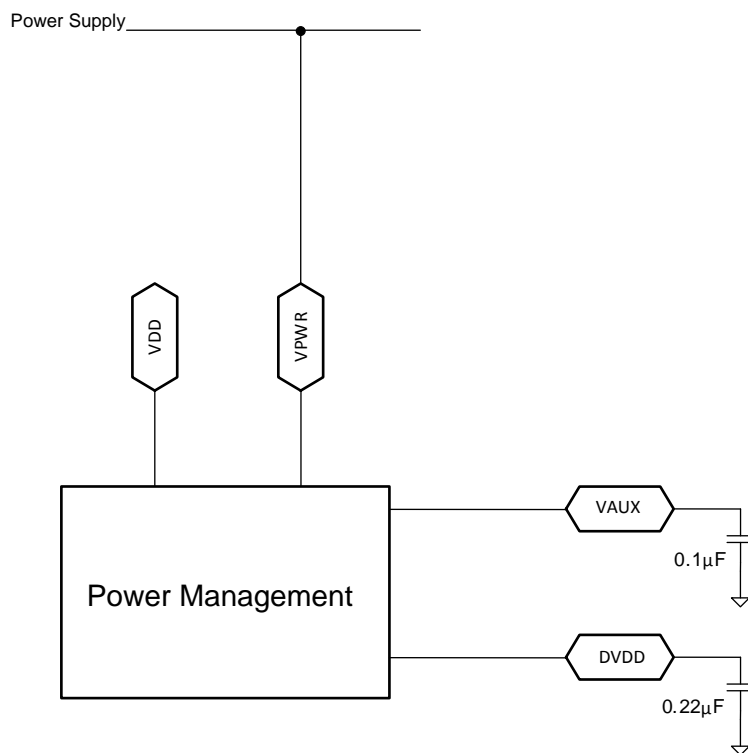

Copyright © 2016, Texas Instruments Incorporated

Figure 37. Power Management

8.3.13 Grounds (AGND, GND)

GND is the substrate ground of the die. Most circuits return to GND, but certain analog circuitry returns to AGND to reduce noise and offsets. The power pad (on those devices that possess one) is electrically connected to GND. Connect AGND, GND and the power pad (if present) to the ground plane through the shortest and most direct connections possible.

8.3.14 Output Power Supply (DVDD)

The DVDD pin is the output of an internal 1.85 V linear regulator, and the input supply for internal digital circuitry. This regulator normally draws power from VPWR until a USB PD contract has stabilized, but will seamlessly swap to drawing power from VDD in the event that VPWR drops below its UVLO threshold. External circuitry can draw up to 35 mA from DVDD. Note that as more power is drawn from the DVDD pin more heat is dissipated in the device, and if excessive the OTSD could be tripped which resets the device. Connect DVDD to GND via the recommended ceramic bypass capacitor.

The DVDD pin will only be high when a USB Type-C sink, or audio accessory, or debug accessory is attached, refer to [Figure 19](#) and [Figure 20](#).

Locate the bypass capacitor close to the pin and provide a low impedance ground connection from the capacitor to the ground plane.

8.4 Device Functional Modes

8.4.1 Sleep Mode

Many adaptors that include USB PD must consume low quiescent power to meet regulatory requirements (that is, “Green,” Energy Star, or such). The device supports the sleep mode to minimize power consumption when the receptacle or plug is unattached. The device enters sleep mode when there is no valid plug termination attached; a valid plug termination is defined as one of: sink, Audio accessory, or Debug accessory. If an active cable is attached but its far-end is left unconnected or “dangling,” then the device also enters sleep mode. It exits the sleep mode whenever the plug status changes, that could be a dangling cable being removed or a sink being connected.

8.4.2 Checking VBUS at Start Up

When first powered up, the device will not enable GDNG if the voltage on VBUS is already above its UVLO. This is a protective measure taken to avoid the possibility of turning on while connected to another active power supply in some non-compliant configuration.

This means that the VBUS pin must be connected between the power-path NFET and the USB connector. This also allows for a controlled discharge of VBUS all the way down to the required voltage on the connector (refer to USB PD in [文档支持](#)).

9 Application and Implementation

NOTE

Information in the following applications sections is not part of the TI component specification, and TI does not warrant its accuracy or completeness. TI's customers are responsible for determining suitability of components for their purposes. Customers should validate and test their design implementation to confirm system functionality.

9.1 Application Information

The TPS25740B implements a fully compliant USB Power Delivery 2.0 provider and Type-C source (also known as downward facing port (DFP)). The device basic schematic diagram is shown in [Figure 38](#). Subsequent sections describe detailed design procedures for several applications with differing requirements. The TPS25740B Design Calculator Tool (refer to USB PD in [文档支持](#)) is available for download and use in calculating the equations in the following sections.

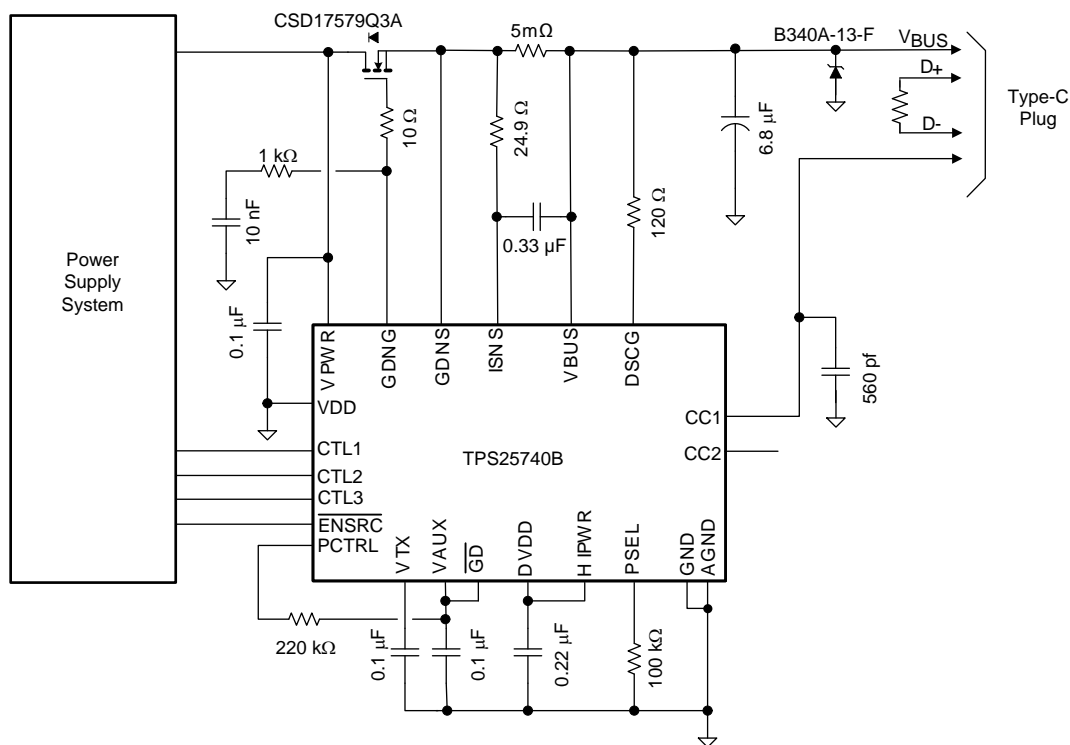

Copyright © 2016, Texas Instruments Incorporated

Figure 38. Basic Schematic Diagram ($P_{(SEL)} = 65\text{ W}$ at 5 V, 9 V, 15 V, 20 V)

9.1.1 System-Level ESD Protection

System-level ESD (per EN61000-4-2) may occur as the result of a cable being plugged in, or a user touching the USB connector or cable. [Figure 39](#) shows an example ESD protection for the VBUS path that helps protect the VBUS pin, ISNS and DSCG pins of the device from system-level ESD. The device has ESD protection built into the CC1 and CC2 pins so that no external protection is necessary. Refer to the [Layout Guidelines](#) section for external component placement and routing recommendations.

The Schottky diode is to protect against VBUS being drawn below ground by an inductive load, the cable inductance may be as high as 900 nH.

Application Information (continued)

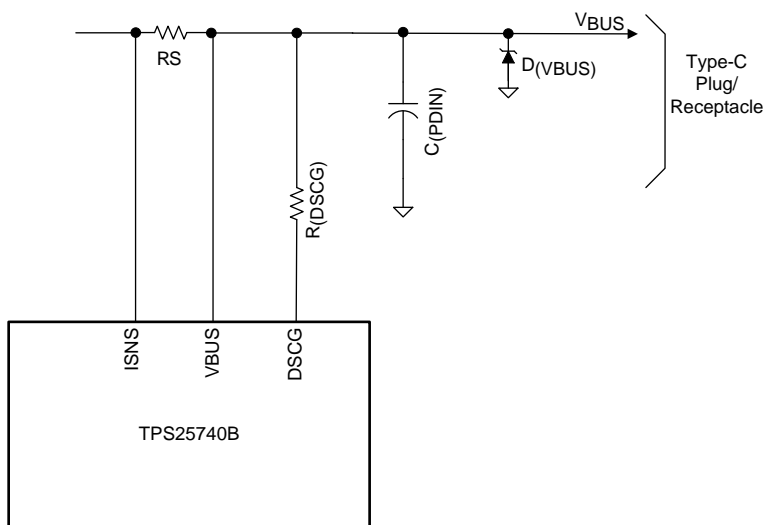

Copyright © 2016, Texas Instruments Incorporated

Figure 39. VBUS ESD Protection

9.1.2 Using $\overline{\text{ENSRC}}$ to Enable the Power Supply upon Sink Attachment

$\overline{\text{ENSRC}}$ may be connected to the enable pin of the power supply as shown in Figure 40. This configuration can eliminate the idle state power loss in the power supply by only turning it on when a sink is attached. In this configuration, VPWR must be connected to a live source so that the TPS25740B can wake upon sink attachment.

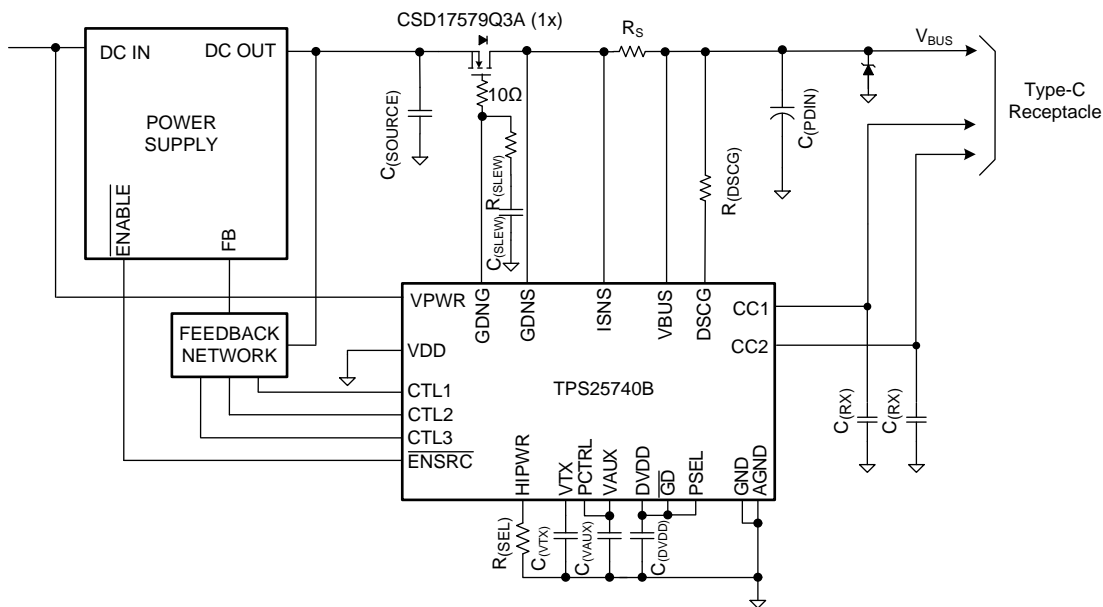

Copyright © 2017, Texas Instruments Incorporated

Figure 40. $\overline{\text{ENSRC}}$ as Power Supply Enable

Application Information (continued)

Another benefit of this configuration is that only one NFET is required to block the source capacitance of the power supply when the socket is cold. This requires that the NFET be oriented with drain towards the type C connector as shown in Figure 40. For this NFET orientation, TPS25740B cannot protect the power supply from over-current events, so the power supply must implement over-current protection. For this case, R_S may be removed with ISNS directly connected to VBUS. Since VBUS follows DC OUT, power supply start-up overshoot must be less than $V_{(SOVP5)}$. ENSRC is set to high-z after a delay of t_{HR} whenever TPS25740B detects a fault that requires a hard reset.

9.1.3 Use of \overline{GD} Internal Clamp

As described in the *Configuring Power Capabilities (PSEL, PCTRL, HIPWR)* section, the \overline{GD} pin has an internal clamp. Figure 41 shows an example of how it may be used. V_{OUT} is the voltage from a power supply that is to be provided onto the VBUS wire of the USB Type-C cable through an NFET resistor. If V_{OUT} drops, the NFET should be automatically disabled by the device. This can be accomplished by tying the \overline{GD} pin to V_{OUT} via a resistor.

The internal resistance of the \overline{GD} pin is specified to exceed $R_{(GD)}$, and the input threshold is $V_{(GD_TH)}$. The \overline{GD} pin would therefore draw no more than $V_{(GD_TH) \max} / R_{(GD) \min} < 603 \text{ nA}$. As an example, assume the minimum value of V_{OUT} for which \overline{GD} should be high is 4.5 V, then the resistor between \overline{GD} and V_{OUT} may not exceed $(4.5 - V_{(GD_TH) \max}) / 603e-9 = 4.5 \text{ M}\Omega$. To make it robust against board leakage a smaller resistor such as 1 M Ω can be chosen, but the smaller the resistance the more leakage current into the \overline{GD} pin. In this example, when V_{OUT} is 25 V, the current into the \overline{GD} pin is $(25 - V_{(GDC)}) / 1e6 < 1.85 \mu\text{A}$.

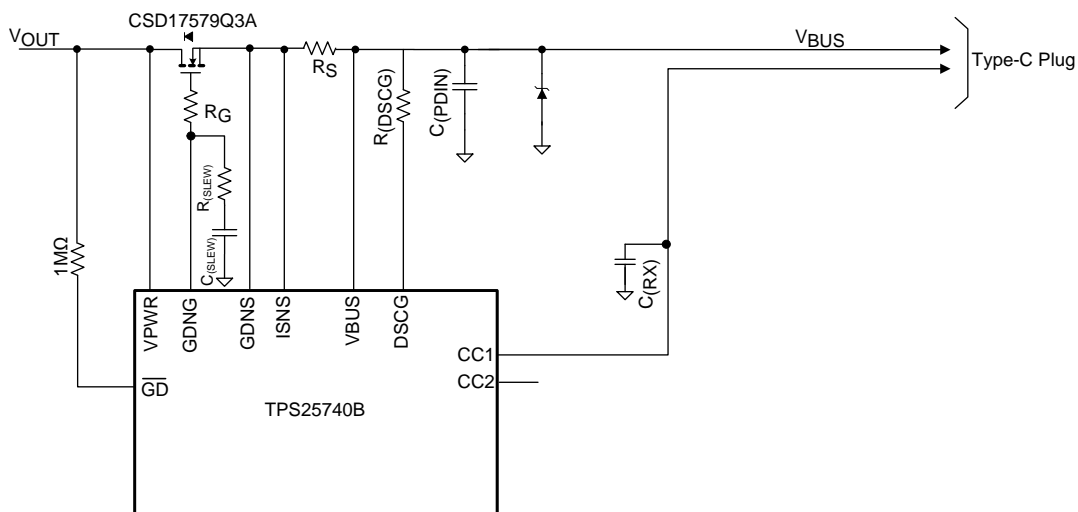

Copyright © 2016, Texas Instruments Incorporated

Figure 41. Use of \overline{GD} Internal Clamp

9.1.4 Resistor Divider on \overline{GD} for Programmable Start Up

Figure 42 shows an alternative usage of the \overline{GD} pin can help protect against shorts on the VBUS pin in the receptacle. A resistor divider is used to minimize the time it takes the \overline{GD} pin to be pulled low. Consider the situation where the VBUS pin is shorted at startup. At some point, the device closes the NFET switch to supply 5 V to VBUS. At that point, the short pulls down on the voltage seen at the VPWR pin. With the resistor values shown in Figure 42, once the voltage at the VPWR pin reaches 3.95 V the voltage at the \overline{GD} pin is specified to be below $V_{(GD_TH) \min}$. Without the 700-k Ω resistor, the voltage at the VPWR pin would have to reach $V_{(GD_TH) \min}$ which takes longer. This comes at the expense of increased leakage current.

Application Information (continued)

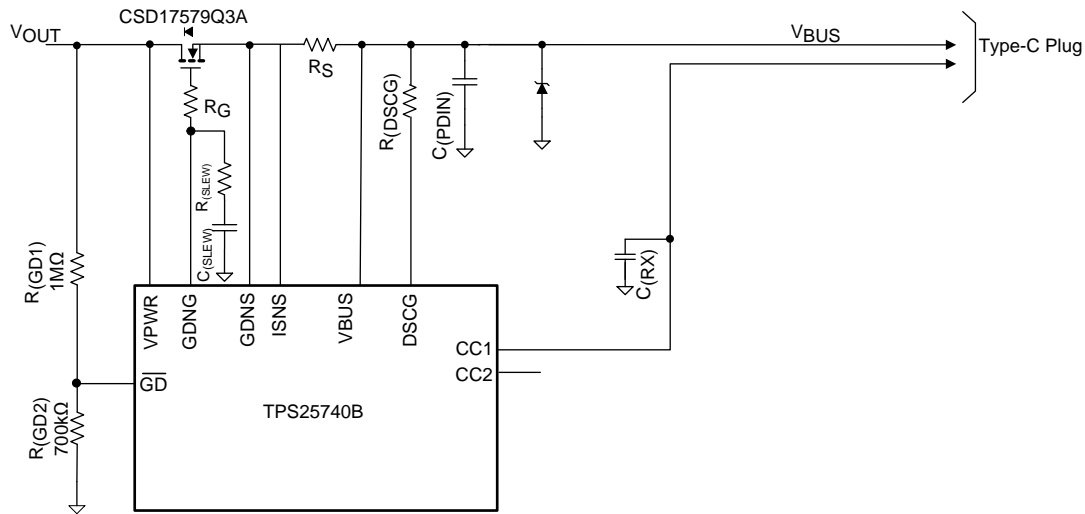

Copyright © 2016, Texas Instruments Incorporated

Figure 42. Programmable $\overline{\text{GD}}$ Turn On

The $\overline{\text{GD}}$ resistor values can be calculated using the following process. First, calculate the smallest $R_{(\text{GD}1)}$ that should be used to prevent the internal clamp current from exceeding $I_{(\text{GD})}$ of 80 μA . For a 20 V advertised voltage, the OVP trip point could be as high as 24 V. Using $V_{(\text{GDC}) \text{ min}} = 6.5 \text{ V}$ and $V_{\text{OUT}} = V_{(\text{FOVP}20) \text{ max}} = 24 \text{ V}$, provides Equation 3:

$$R_{(\text{GD}1)} > \frac{V_{(\text{FOVP}20)} - V_{(\text{GDC})}}{I_{(\text{GD})}} = \frac{24 \text{ V} - 6.5 \text{ V}}{80 \mu\text{A}} = 219 \text{ k}\Omega \quad (3)$$

The actual clamping current is less than 80 μA as some current flows into $R_{(\text{GD}2)}$. Next, $R_{(\text{GD}2)}$ can be calculated as shown in Equation 4:

$$R_{(\text{GD}2)} < R_{(\text{GD}1)} \times \frac{V_{(\text{GD_TH})}}{V_{(\text{VPWR})} - V_{(\text{GD_TH})}}$$

where

- $V_{(\text{VPWR})} = V_{(\text{VPWR_TH})}$ falling (max) and $V_{(\text{GD_TH})} = V_{(\text{GD_TH})}$ falling (min).

9.1.5 Selection of the CTL1, CTL2, and CTL3 Resistors ($R_{(\text{FBL}1)}$, $R_{(\text{FBL}2)}$, and $R_{(\text{FBL}3)}$)

$R_{(\text{FBL}1)}$, $R_{(\text{FBL}2)}$, and $R_{(\text{FBL}3)}$ provide a means to change the power supply output voltage when switched in by the CTL1, CTL2, and CTL3 open drain outputs, respectively. When CTLx is driven low it will place $R_{(\text{FBL}x)}$ in parallel with $R_{(\text{FBL})}$.

Application Information (continued)

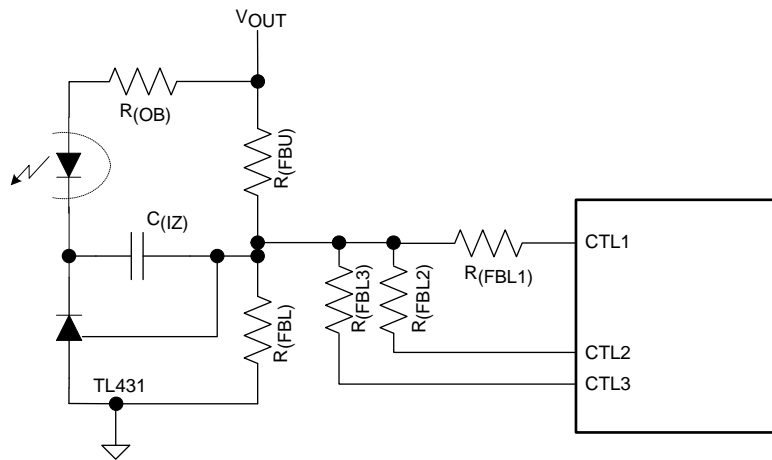

Copyright © 2016, Texas Instruments Incorporated

Figure 43. Circuit to Change V_{OUT} Upon Sink/UFP Request

R_(FBL2) is calculated using Equation 5. In this example, V_{OUT9} is 9 V, V_{OUT15} is 15 V, and V_{OUT20} is 20 V. V_{OUT} is the default output voltage (5 V) for the regulator and is set by R_(FBU), R_(FBL) and error amplifier V_{REF}.

$$R_{(FBL2)} = \frac{R_{(FBL)} \times R_{(FBU)} \times V_{REF}}{R_{(FBL)} \times (V_{OUT9} - V_{REF}) - R_{(FBU)} \times V_{REF}} \tag{5}$$

R_(FBL1) is calculated using Equation 6 after a standard 1% value for R_(FBL2) is chosen.

$$R_{(FBL1)} = \frac{\frac{R_{(FBL2)} \times R_{(FBL)}}{R_{(FBL2)} + R_{(FBL)}} \times R_{(FBU)} \times V_{REF}}{\frac{R_{(FBL2)} \times R_{(FBL)}}{R_{(FBL2)} + R_{(FBL)}} \times (V_{OUT15} - V_{REF}) - R_{(FBU)} \times V_{REF}} \tag{6}$$

$$R_{(FBL3)} = \frac{\frac{R_{(FBL1)} \times R_{(FBL2)} \times R_{(FBL)}}{R_{(FBL)} \times (R_{(FBL2)} + R_{(FBL1)}) + R_{(FBL2)} \times R_{(FBL1)}} \times R_{(FBU)} \times V_{REF}}{\frac{R_{(FBL1)} \times R_{(FBL2)} \times R_{(FBL)}}{R_{(FBL)} \times (R_{(FBL2)} + R_{(FBL1)}) + R_{(FBL2)} \times R_{(FBL1)}} \times (V_{OUT20} - V_{REF}) - R_{(FBU)} \times V_{REF}} \tag{7}$$

R_(FBLx) resistors should be large enough so that the corresponding CTL_x sinking current is minimized (< 1 mA). The sinking current for CTL_x is V_{REF} / R_(FBLx).

9.1.6 Voltage Transition Requirements

During VBUS voltage transitions, the slew rate (v_{SrcSlewPos}) must be kept below 30 mV/μs in all portions of the waveform, settle (t_{SrcSettle}) in less than 275 ms, and be ready (t_{SrcReady}) in less than 285 ms. For most power supplies, these requirements are met naturally without any special circuitry but in some cases, the voltage transition ramp rate must be slowed in order to meet the slew rate requirement.

The requirements for linear voltage transitions are shown in Table 5. In all cases, the minimum slew time is below 1 ms.

Table 5. Minimum Slew-Rate Requirements

VOLTAGE TRANSITION	5 V ↔ 12 V	5 V ↔ 20 V	12 V ↔ 20 V	5 V ↔ 9 V	5 V ↔ 15 V	9 V ↔ 15 V	9 V ↔ 12 V	12 V ↔ 15 V	9 V ↔ 20 V	15 V ↔ 20 V
Minimum Slew Time	233 μs	500 μs	267 μs	133 μs	333 μs	200 μs	100 μs	100 μs	367 μs	167 μs

When transition slew control is required, the interaction of the slew mechanism and dc/dc converter loop response must be considered. A simple R-C filter between the device CTL pins and converter feedback node may lead to instability under some conditions. Figure 44 shows a method which controls the slew rate without adding capacitance to the converter feedback node.

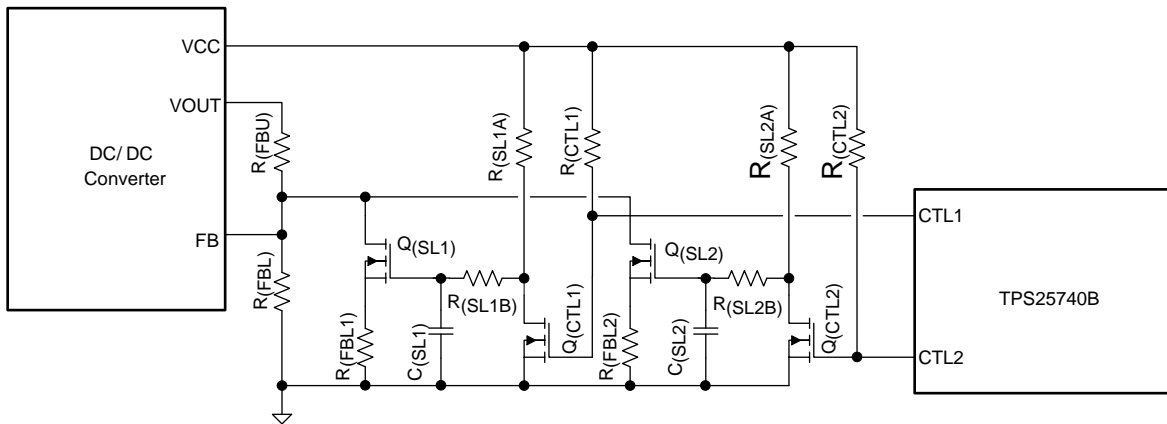

Copyright © 2016, Texas Instruments Incorporated

Figure 44. Slew-Rate Control Example No. 1

When $V_{OUT} = 5\text{ V}$, all CTL pins are in a high impedance state. When a 5 V to 12 V transition is requested, CTL2 goes low and turns off $Q_{(CTL2)}$. $Q_{(SL2)}$ gate starts to rise towards VCC at a rate determined by $R_{(SL2A)} + R_{(SL2B)}$ and $C_{(SL2)}$. $Q_{(SL2)}$ gate continues to rise, until $Q_{(SL2)}$ is fully enhanced placing $R_{(FBL2)}$ in parallel with $R_{(FBL)}$. In similar fashion when $C_{(TL1)}$ goes low, $Q_{(CTL1)}$ turns off allowing $R_{(FBL1)}$ to slew in parallel with $R_{(FBL2)}$ and $R_{(FBL)}$.

The slewing resistors and capacitor can be chosen using the following equations. V_T is the VGS threshold voltage of $Q_{(SL1)}$ and $Q_{(SL2)}$. V_{REF} is the feedback regulator reference voltage. Choose the slewing resistance in the 100 kΩ range to reduce the loading on the bias voltage source (VCC) and then calculate $C_{(SL)}$. The falling transitions is shorter than the rising transitions in this topology.

Falling transitions:

- 20 V to 12 V

$$R_{(SL1B)} \times C_{(SL1)} = \frac{\Delta T_{20V - 12V}}{\ln\left(\frac{V_T + V_{REF}}{V_{(VCC)}}\right) - \ln\left(\frac{V_T}{V_{(VCC)}}\right)} \quad (8)$$

- 12 V to 5 V

$$R_{(SL2B)} \times C_{(SL2)} = \frac{\Delta T_{12V - 5V}}{\ln\left(\frac{V_T + V_{REF}}{V_{(VCC)}}\right) - \ln\left(\frac{V_T}{V_{(VCC)}}\right)} \quad (9)$$

Rising transitions:

- 5 V to 12 V

$$(R_{(SL2A)} + R_{(SL2B)}) \times C_{(SL2)} = \frac{\Delta T_{5V - 12V}}{\ln\left(1 - \frac{V_T}{V_{(VCC)}}\right) - \ln\left(1 - \frac{V_T + V_{REF}}{V_{(VCC)}}\right)} \quad (10)$$

- 12 V to 20 V

$$(R_{(SL1A)} + R_{(SL1B)}) \times C_{(SL1)} = \frac{\Delta T_{12V - 20V}}{\ln\left(1 - \frac{V_T}{V_{(VCC)}}\right) - \ln\left(1 - \frac{V_T + V_{REF}}{V_{(VCC)}}\right)} \quad (11)$$

Some converter regulators can tolerate a balance of capacitance on the feedback node without affecting loop stability. The LM5175 has been tested using [Figure 45](#) to combine V_{OUT} slewing with a minimal amount of extra circuitry.

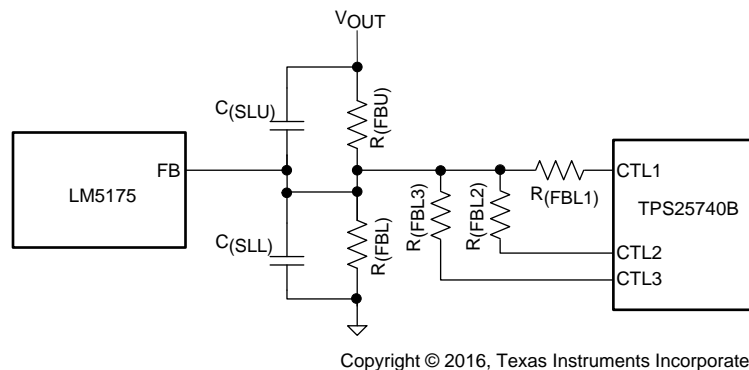

Figure 45. Slew-Rate Control Example No. 2

When a higher voltage is requested from TPS25740B, at least one of the CTL pins goes low changing the sensed voltage at the FB pin. The LM5175 compensates by increasing $C_{(SLU)}$. As V_{OUT} increases, $C_{(SLU)}$ is charged at a rate proportional to $R_{(FBU)}$. Three time constants yields a voltage change of approximately 95% and can be used to calculate the desired slew time. $C_{(SLU)}$ can be calculated using [Equation 12](#) and [Equation 13](#).

$$\Delta T_{(SLEW)} = 3 \times R_{(FBU)} \times C_{(SLU)} \quad (12)$$

$$C_{(SLU)} = \frac{\Delta T_{(SLEW)}}{3 \times R_{(FBU)}} \quad (13)$$

In order to minimize loop stability effects, a capacitor in parallel with $R_{(FBL)}$ is required. The ratio of $C_{(SLU)}/C_{(SLL)}$ should be chosen to match the ratio of $R_{(FBL)}/R_{(FBU)}$. Choose $C_{(SLL)}$ according to [Equation 14](#).

$$C_{(SLL)} = C_{(SLU)} \times \frac{R_{(FBU)}}{R_{(FBL)}} \quad (14)$$

A third slew rate method is shown in [Figure 46](#) using an equivalent resistance, R_{EQ} and $C_{(SLL)}$ to provide an exponential slew rate. The slew rate is the derivative of the voltage ramp with the maximum occurring at the beginning of a transition. A DC-DC converter with programmable soft-start can help minimize V_{OUT} overshoot at start-up due to $C_{(SLL)}$. Any V_{OUT} overshoot must decay below $V_{(SOVP5)}$ before TPS25740B applies V_{BUS} in order to prevent OVP shutdown.

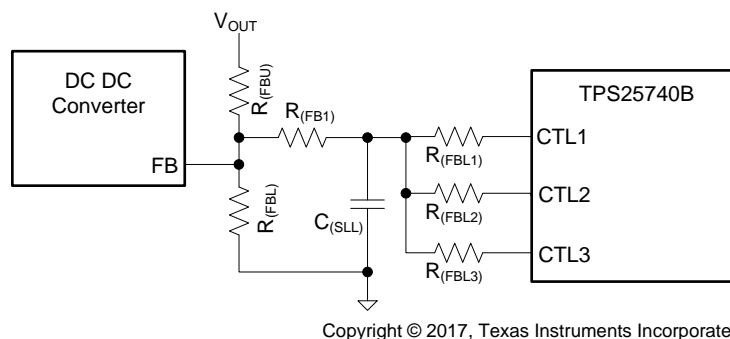

Figure 46. Slew-Rate Control Example No. 3

For the rising condition, TPS25740B will connect one or more of the $R_{(FBLx)}$ resistors in parallel with $C_{(SLL)}$. The FB node is treated as a virtual ground so that R_{EQ} for the rising condition is $R_{(FB1)}$ in parallel with the $R_{(FBLx)}$ resistors being grounded through the CTLx pins. For the falling condition, TPS25740B will disconnect one or more of the $R_{(FBLx)}$ resistors in parallel with $C_{(SLL)}$. R_{EQ} for the falling condition is therefore $R_{(FB1)}$ in parallel with the $R_{(FBLx)}$ resistors remaining grounded.

$$SR \left(\frac{mV}{\mu s} \right) = \frac{\Delta V_{BUS}}{1000 \times R_{EQ} \times C_{(SLL)}} \times e^{\frac{-t}{R_{EQ} \times C_{(SLL)}}}$$

where

- $SR = SR(\max)$ at $t = 0$ (15)

$$SR(\max) \left(\frac{mV}{\mu s} \right) = \frac{\Delta V_{BUS}}{1000 \times R_{EQ} \times C_{(SLL)}} \quad (16)$$

The slew rate is proportional to V_{BUS} voltage change and the largest slew rate occurs for the 5 V to 20 V case (or 15 V if 15 V is the highest advertised voltage) where all three $R_{(FBLX)}$ resistors are connected simultaneously. Size $C_{(SLL)}$ for this case using $R_{EQ} = R_{(FB1)}, R_{(FBL1)}, R_{(FBL2)},$ and $R_{(FBL3)}$ in parallel.

For this method, the procedure to choose the voltage programming resistors differs from the examples in section [Selection of the CTL1, CTL2, and CTL3 Resistors \(\$R_{\(FBL1\)}, R_{\(FBL2\)},\$ and \$R_{\(FBL3\)}\$ \)](#) due to the addition of $R_{(FB1)}$. The TPS25740B Design Calculator Tool (refer to USB PD in [文档支持](#)) is available to help with the calculations for this control method. All slew rate control methods should be verified on the bench to ensure that the slew rate requirements are being met when the external VBUS capacitance is between 1 μF and 100 μF .

9.1.7 V_{BUS} Slew Control using GDNG $C_{(SLEW)}$

Care should be taken to control the slew rate of Q1 using $C_{(SLEW)}$; particularly in applications where $C_{OUT} \gg C_{(SLEW)}$. The slew rate observed on VBUS when charging a purely capacitive load is the same as the slew rate of $V_{(GDNG)}$ and is dominated by the ratio $I_{(GDNON)} / C_{(SLEW)}$. $R_{(SLEW)}$ helps block $C_{(SLEW)}$ from the GDNG pin enabling a faster transient response to OCP.

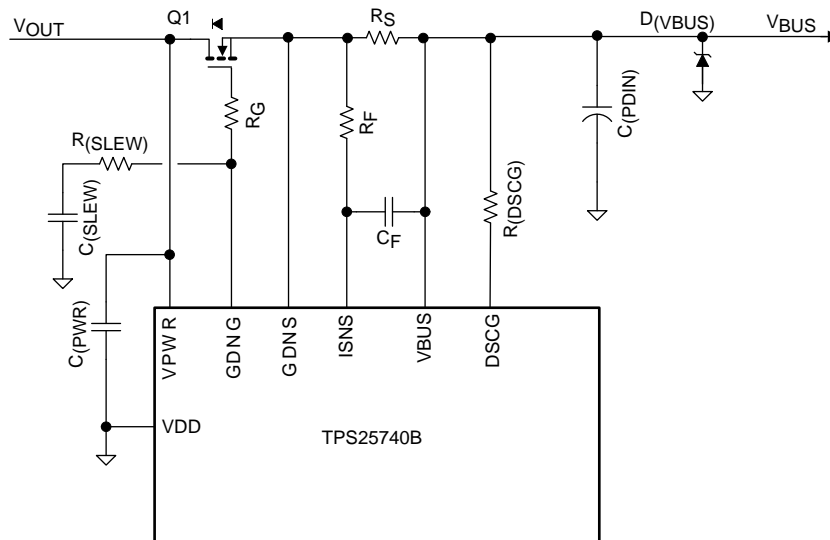

Copyright © 2016, Texas Instruments Incorporated

Figure 47. Slew-Rate control Using GDNG

There may be fault conditions where the voltage on VBUS triggers an OVP condition and then remains at a high voltage even after the TPS25740B configures the voltage source to output 5 V via the CTL pins. When this OVP occurs, the TPS25740B opens Q1 within $t_{FOVP} + t_{FOVPDG}$. The TPS25740B then issues a hard reset, discharge the power-path via the $R_{(DSCG)}$, and waits for 795 ms before enabling Q1 again. Due to the fault condition the voltage again triggers an OVP event when the voltage on VBUS exceeds $V_{(FOVP)}$. This retry process would continue as long as the fault condition persists, periodically pulsing up to $V_{(FOVP)} + V_{SrcSlewPos} \times (t_{FOVP} + t_{FOVPDG})$ onto the VBUS of the Type-C receptacle. It is recommended to use a slew rate less than the maximum of $V_{SrcSlewPos}$ (30 mV / μs) allowed by USB (refer to [文档支持](#)), the slew rate should instead be set in order to meet the requirement to have the voltage reach the target voltage within $t_{SrcSettle}$ (275 ms). This also limits the out-rush current from the C_{OUT} capacitor into the $C_{(PDIN)}$ capacitor and help protect Q1 and R_S .

9.1.8 Tuning OCP using R_F and C_F

In applications where there are load transients or moderate ripple on V_{OUT} , the OCP performance of TPS25740B may be impacted. Adding the R_F/C_F filter network as shown in Figure 48 helps mitigate the impact of the ripple and load transients on OCP performance.

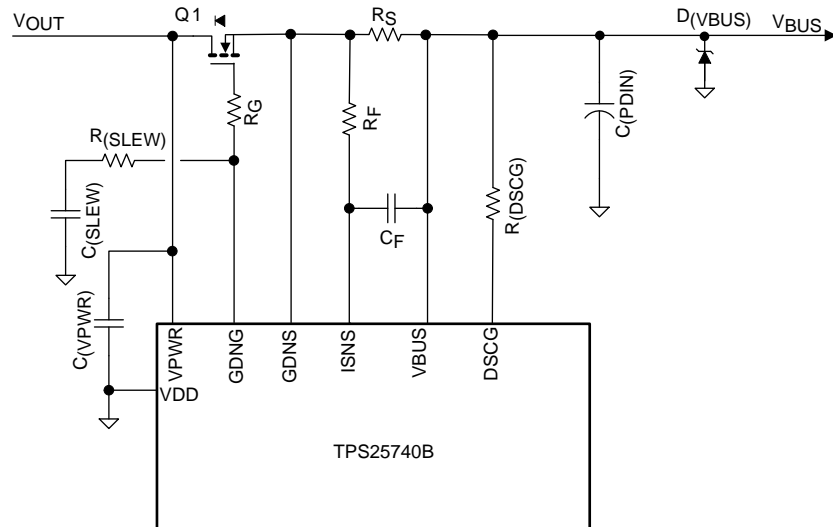

Copyright © 2016, Texas Instruments Incorporated

Figure 48. ISNS Filtering Example

R_F/C_F can be tailored to the amount of ripple on V_{OUT} as shown in Table 6.

Table 6. Ripple on V_{OUT}

FREQUENCY x RIPPLE (kHz x V)	SUGGESTED FILTER TIME CONSTANT (μ s)
< 5 (Ex: 50 mV ripple at 100 kHz)	None
5 to 15	2.2 μ s ($R_F = 10 \Omega$, $C_F = 220$ nF)
15 to 35	4.7 μ s ($R_F = 10 \Omega$, $C_F = 470$ nF)
35 to 105	10 μ s ($R_F = 10 \Omega$, $C_F = 1$ μ F)

9.2 Typical Applications

9.2.1 Typical Application, A/C Power Source (Wall Adapter)

In this design example, PSEL pin is configured so that $P_{(SEL)} = 65\text{ W}$ (see Table 7). Voltages offered are 5 V, 9 V, 15 V, and 20 V at a maximum of 3 A. The overcurrent protection (OCP) trip point is set just above 3 A and VDD on the TPS25740B is grounded. The following example is based on PMP11451 and PMP11455, see www.ti.com/tool/PMP11451. In this design, the TPS25740B and some associated discretes are located on the paddle card (PMP11455) which plugs into the power supply card (PMP11451). This allows different paddle cards with different power and voltage advertisements to be used with a common power supply design.

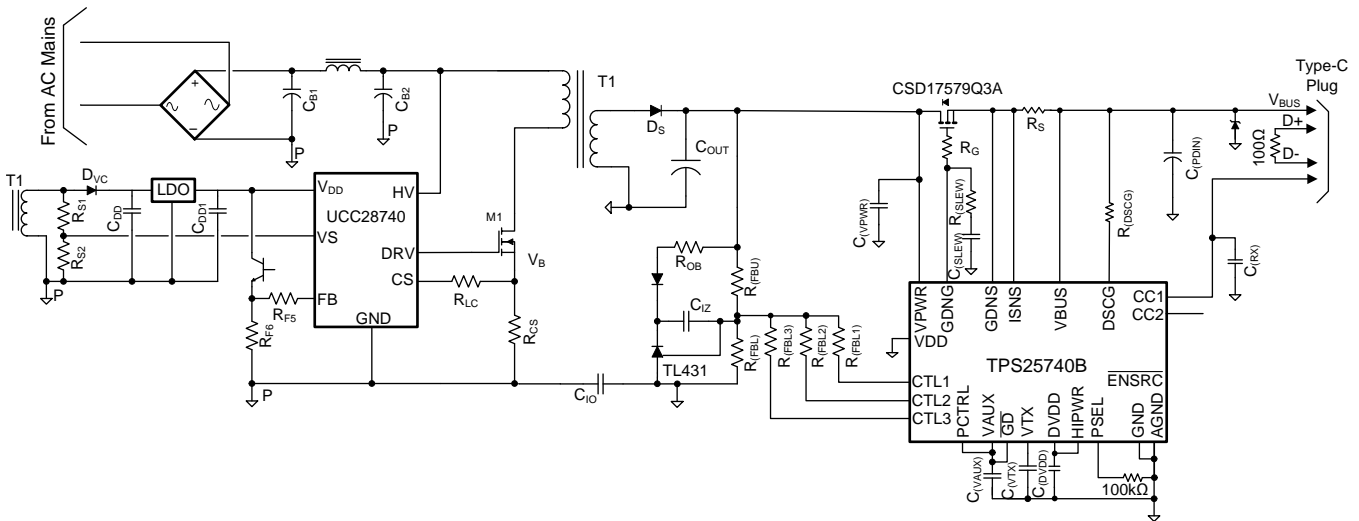

Copyright © 2016, Texas Instruments Incorporated

Figure 49. Captive Cable Adapter Provider Conceptual Schematic

9.2.1.1 Design Requirements

Table 7. Design Parameters

DESIGN PARAMETER	VALUE
Configured Power Limit, $P_{(SEL)}$	65 W
Advertised Voltages	5 V, 9V, 15V, 20 V
Advertised Current Limit	3 A
Over Current Protection Set point	4.2 A

9.2.1.2 Detailed Design Procedure

9.2.1.2.1 Power Pin Bypass Capacitors

- $C_{(VPWR)}$: 0.1 μF , 50 V, $\pm 10\%$, X7R ceramic at pin 20 (VPWR)
- $C_{(VDD)}$: 0.1 μF , 50 V, X7R ceramic at pin 17 (VDD). If VDD is not used in the application, then tie VDD to GND.
- $C_{(DVDD)}$: 0.22 μF , 10 V, $\pm 10\%$, X5R ceramic at pin 13 (DVDD)
- $C_{(VAUX)}$: 0.1 μF , 50 V, $\pm 10\%$, X7R ceramic at pin 16 (VAUX)
- $C_{(VTX)}$: 0.1 μF , 50 V, $\pm 10\%$, X7R ceramic at pin 1 (VTX)

9.2.1.2.2 Non-Configurable Components

- $R_{(SEL)}$: When the application requires advertisement using $R_{(SEL)}$, use a 100 k Ω , $\pm 1\%$ resistor.
- $R_{(PCTRL)}$: If PCTRL will be pulled low with an external device then it can be connected to VAUX using a 220 k Ω , $\pm 1\%$ resistor. If PCTRL is always high, then it can be directly connected to VAUX.
- $R_{(SLEW)}$: Use a 1 k Ω , $\pm 1\%$ resistor

- R_G : Use a 10 Ω , $\pm 1\%$ resistor

9.2.1.2.3 Configurable Components

- $C_{(RX)}$: Choose $C_{(RX)}$ between 200 pF and 600 pF. A 560 pF, 50 V, $\pm 5\%$ COG/NPO ceramic is recommended for both CC1 and CC2 pins.
- Q_1 : For a 3 A application, an N-Channel MOSFET with $R_{DS(on)}$ in the 10 m Ω range is sufficient. $BV_{(DSS)}$ should be rated for 30 V for applications delivering 20 V, and 25 V for 12 V applications. For this application, the TI CSD17579Q3A (SLPS527) NexFET™ is suitable.
- R_S : TPS25740B OCP set point thresholds are targeted towards a 5 m Ω , $\pm 1\%$ sense resistor. Power dissipation for R_S at 3 A load is approximately 45 mW.
- $R_{(DSCG)}$: The minimum value of $R_{(DSCG)}$ is chosen based on the application V_{BUS} (max) and $I_{(DSCGT)}$. For V_{BUS} (max) = 12 V and $I_{(DSCGT)} = 350$ mA, $R_{(DSCG(min))} = 34.3$ Ω . The size of the external resistor can then be chosen based on the capacitive load that needs to be discharged and the maximum allowed discharge time of 265 ms. Typically, a 120 Ω , 0.5 W resistor provides suitable performance.
- R_F/C_F : Not used
- $C_{(PDIN)}$: The requirement for $C_{(PDIN)}$ is 10 μ F maximum. A 6.8 μ F, 25 V, $\pm 10\%$ X5R or X7R ceramic capacitor is suitable for most applications.
- $D_{(VBUS)}$: $D_{(VBUS)}$ provides reverse transient protection during large transient conditions when inductive loads are present. A Schottky diode with a $V_{(RRM)}$ rating of 30 V in a SMA package such as the B340A-13-F provides suitable reverse voltage clamping performance.
- $C_{(SLEW)}$: To achieve a slew rate from zero to 5 V of less than 30 mV / μ s using the typical GDNG current of 20 μ A then $C_{(SLEW)} > 20$ μ A / 30 mV / μ s = 0.67 nF be used. Choosing $C_{(SLEW)} = 10$ nF yields a ramp rate of 2 mV / μ s.
- $R_{(FBL1)}/R_{(FBL2)}/R_{(FBL3)}$: In this design example, $R_{(FBU)} = 20$ k Ω and $R_{(FBL)} = 20$ k Ω . The feedback error amplifier is TL431AI which is rated for up to 36 V operation and $V_{REF} = 2.495$ V. Using the equation for $R_{(FBL2)}$ above yields a calculated value of 12.44 k Ω and a selected value of 12.4 k Ω . In similar fashion for $R_{(FBL1)}$, the equation yields a calculated value of 8.34 k Ω and a selected value of 8.25 k Ω . Lastly for $R_{(FBL3)}$, the calculated value is 10.1 k Ω with a selected value of 10 k Ω .

9.2.1.3 Application Curves

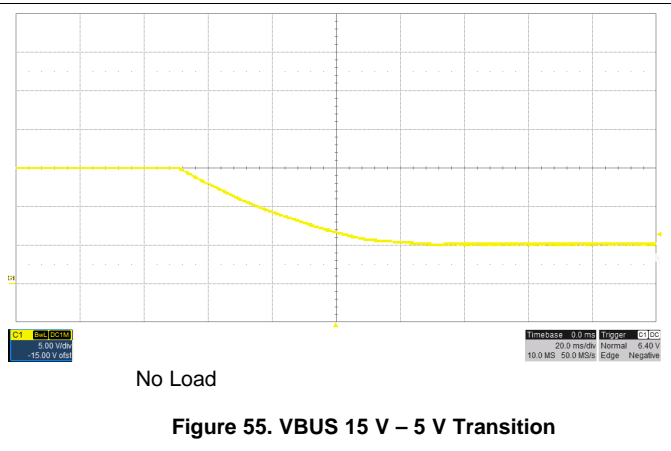
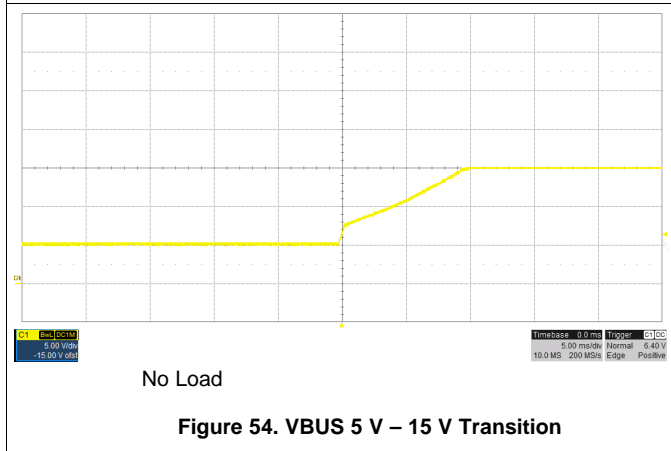
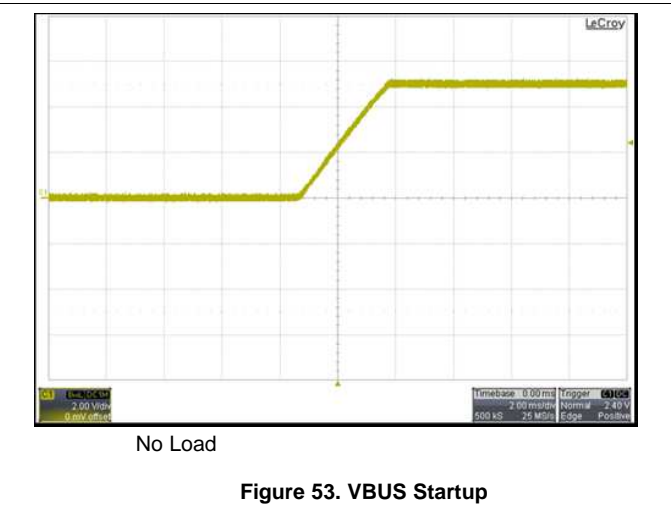
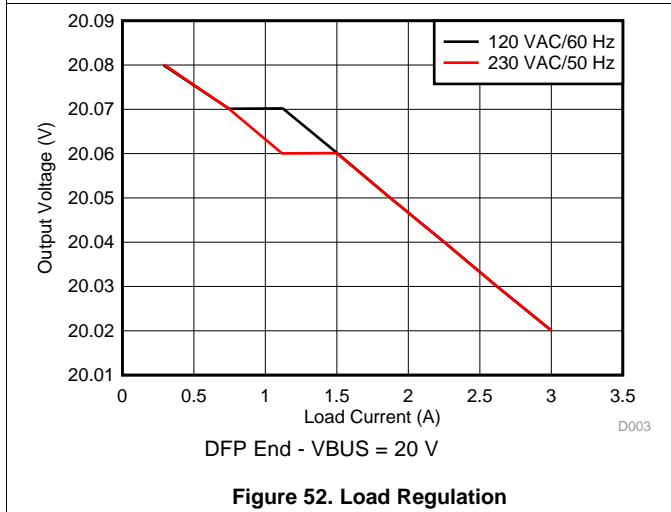
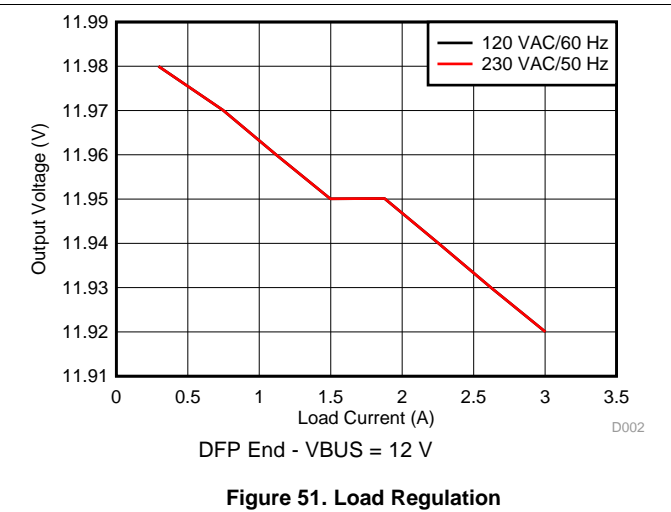
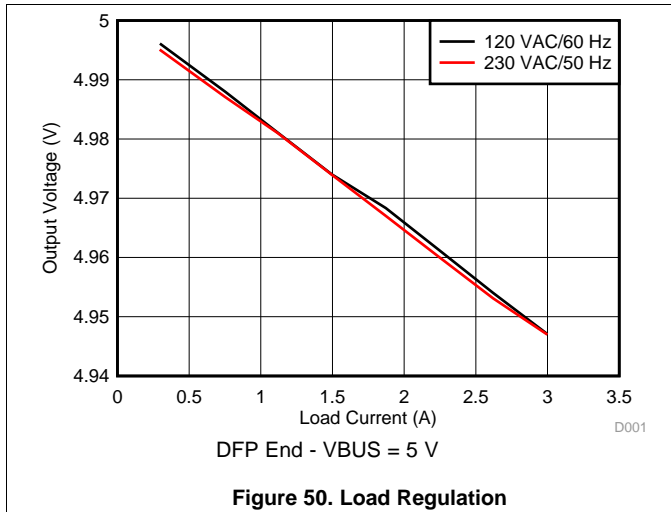

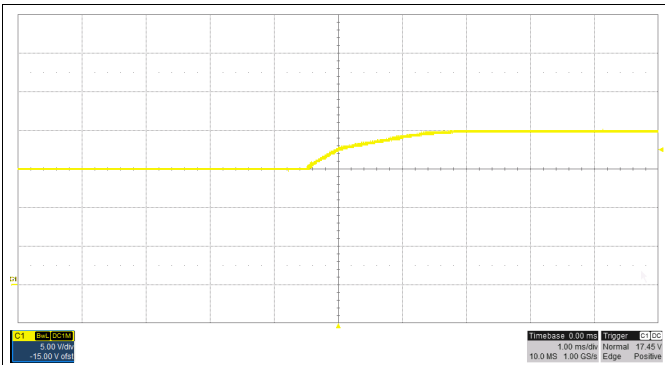

No Load

Figure 56. VBUS 15 V – 20 V Transition

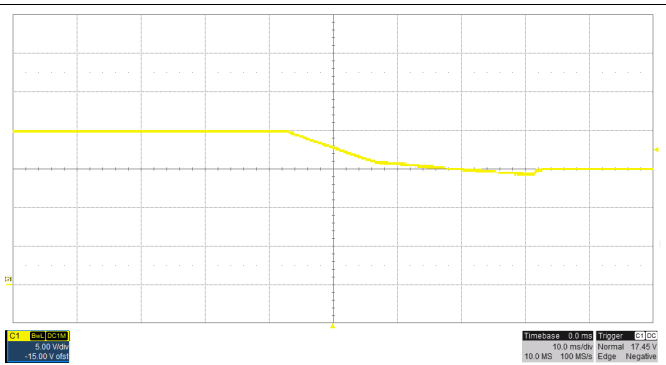

No Load

Figure 57. VBUS 20 V – 15 V Transition

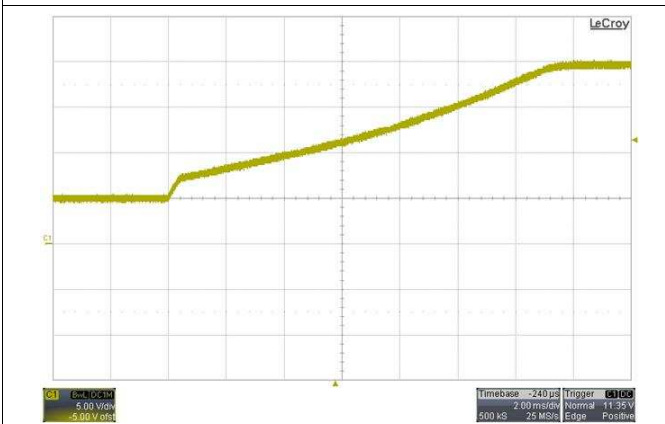

No Load

Figure 58. VBUS 5 V – 20 V Transition

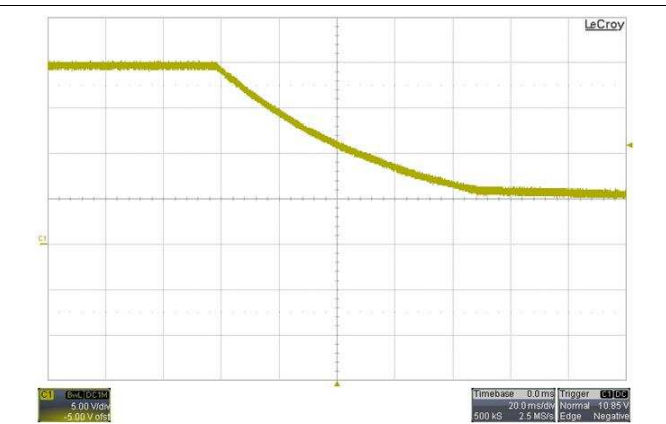

No Load

Figure 59. VBUS 20 V – 5 V Transition

9.2.2 Typical Application, D/C Power Source

In this design example the PSEL pin is configured such that $P_{(SEL)} = 65\text{ W}$ (see Table 8). Voltages offered are 5 V, 9 V, 15 V, and 20 V at a maximum of 3 A. The overcurrent protection (OCP) trip point is set just above 3 A and VDD on the TPS25740B is grounded. The following example is based on TPS25740BEVM-741 (refer to 文档支持).

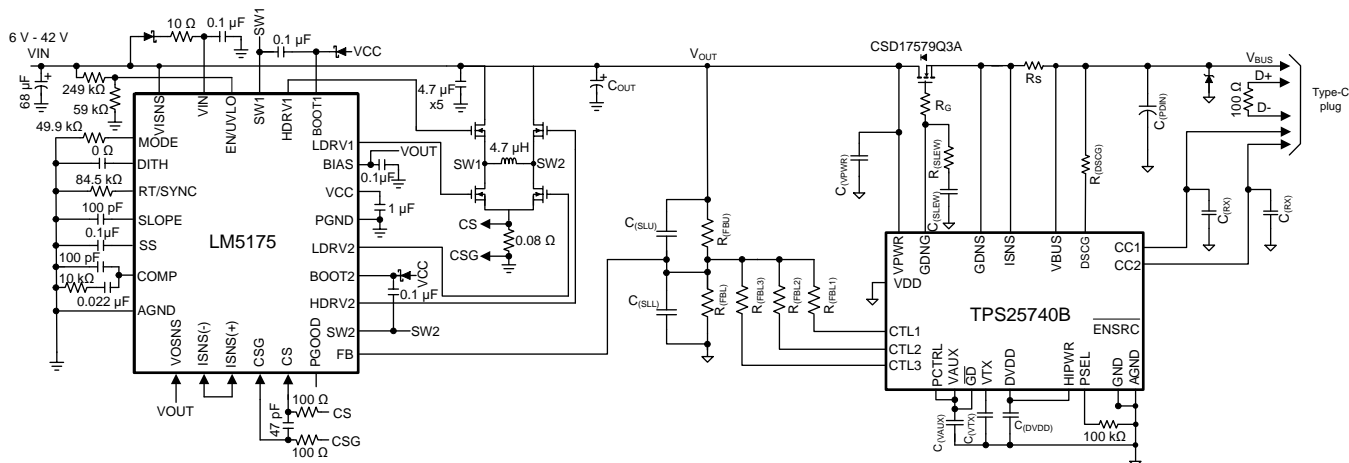

Copyright © 2016, Texas Instruments Incorporated

Figure 60. DC Power Source

9.2.2.1 Design Requirements

Table 8. Design Parameters

DESIGN PARAMETER	VALUE
Configured Power Limit, $P_{(SEL)}$	65 W
Advertised Voltages	5 V, 9 V, 15 V, 20 V
Advertised Current Limit	3 A
Over Current Protection Set point	4.2 A

9.2.2.2 Detailed Design Procedure

9.2.2.2.1 Power Pin Bypass Capacitors

- $C_{(VPWR)}$: 0.1 μF , 50 V, $\pm 10\%$, X7R ceramic at pin 20 (VPWR)
- $C_{(VDD)}$: 0.1 μF , 50 V, X7R ceramic at pin 17 (VDD). If VDD is not used in the application, then tie VDD to GND.
- $C_{(DVDD)}$: 0.22 μF , 10 V, $\pm 10\%$, X5R ceramic at pin 13 (DVDD)
- $C_{(VAUX)}$: 0.1 μF , 50 V, $\pm 10\%$, X7R ceramic at pin 16 (VAUX)
- $C_{(VTX)}$: 0.1 μF , 50 V, $\pm 10\%$, X7R ceramic at pin 1 (VTX)

9.2.2.2.2 Non-Configurable Components

- $R_{(SEL)}$: When the application requires advertisement using $R_{(SEL)}$, use a 100 k Ω , $\pm 1\%$ resistor.
- $R_{(PCTRL)}$: If PCTRL will be pulled low with an external device then it can be connected to VAUX using a 220 k Ω , $\pm 1\%$ resistor. If PCTRL will always be high then it can be directly connected to VAUX.
- $R_{(SLEW)}$: Use a 1 k Ω , $\pm 1\%$ resistor
- R_G : Use a 10 Ω , $\pm 1\%$ resistor

9.2.2.2.3 Configurable Components

- $C_{(RX)}$: Choose $C_{(RX)}$ between 200 pF and 600 pF. A 560 pF, 50 V, $\pm 5\%$ COG/NPO ceramic is recommended for both CC1 and CC2 pins.
- Q_1 : For a 3 A application, an N-Channel MOSFET with $R_{DS(on)}$ in the 10 m Ω range is sufficient. $BV_{(DSS)}$ should be rated for 30 V for applications delivering 20 V, and 25 V for 15 V applications. For this application, the TI CSD17579Q3A (SLPS527) NexFET™ is suitable.
- R_S : TPS25740B OCP set point thresholds are targeted towards a 5 m Ω , $\pm 1\%$ sense resistor. Power dissipation for R_S at 3 A load is approximately 45 mW.
- $R_{(DSCG)}$: The minimum value of $R_{(DSCG)}$ is chosen based on the application VBUS (max) and $I_{(DSCGT)}$. For VBUS (max) = 15 V and $I_{(DSCGT)} = 350$ mA, $R_{DS(CG(min))} = 42.9 \Omega$. The size of the external resistor can then be chosen based on the capacitive load that needs to be discharged and the maximum allowed discharge time of 265 ms. Typically, a 120 Ω , 0.5 W resistor provides suitable performance.
- R_F/C_F : Not used
- $C_{(PDIN)}$: The requirement for $C_{(PDIN)}$ is 10 μ F maximum. A 6.8 μ F, 25 V, $\pm 10\%$ X5R or X7R ceramic capacitor is suitable for most applications.
- $D_{(VBUS)}$: $D_{(VBUS)}$ provides reverse transient protection during large transient conditions when inductive loads are present. A Schottky diode with a $V_{(RRM)}$ rating of 30 V in a SMA package such as the B340A-13-F provides suitable reverse voltage clamping performance.
- $C_{(SLEW)}$: To achieve a slew rate from zero to 5 V of less than 30 mV / μ s using the typical GDNG current of 20 μ A then $C_{(SLEW)} (nF) > 20 \mu A / 30 mV / \mu s = 0.67 nF$ be used. Choosing $C_{(SLEW)} = 10$ nF yields a ramp rate of 2 mV / μ s.
- $R_{(FBL1)}/R_{(FBL2)}/R_{(FBL3)}$: In this design example, $R_{(FBU)} = 49.9$ k Ω and $R_{(FBL)} = 9.53$ k Ω . The feedback error amplifier $V_{REF} = 0.8$ V. Using the equations for $R_{(FBL2)}$ (Equation 5 and Equation 6) provide a calculated value of 9.9 k Ω and a selected value of 9.76 k Ω . In similar fashion for $R_{(FBL1)}$, a calculated value of 6.74 k Ω and a selected value of 6.65 k Ω is provided. Lastly for $R_{(FBL3)}$, the calculated value is 8.1 k Ω with a selected value of 8.06 k Ω .
- $C_{(SLU)}/C_{(SLL)}$: The value of $C_{(SLU)}$ is calculated based on the desired 95% slew rate using Equation 13 and Equation 14. Choose a 22 nF capacitor for $C_{(SLU)}$. Choose a 100 nF capacitor for $C_{(SLL)}$.

9.2.2.3 Application Curves

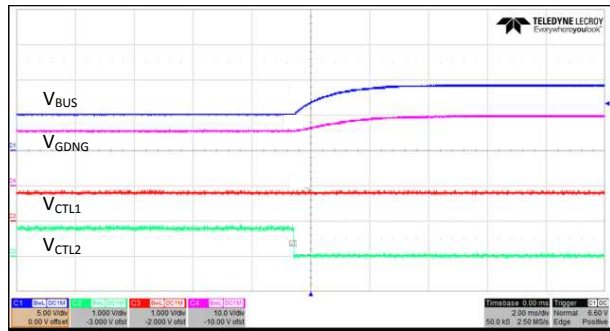

No Load

Figure 61. VBUS 5 V – 9 V Transition

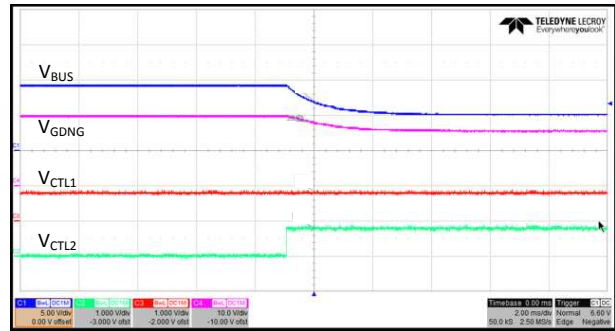

No Load

Figure 62. VBUS 9 V – 5 V Transition

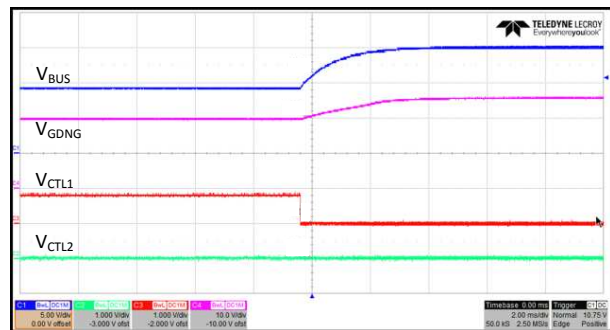

No Load

Figure 63. VBUS 9 V – 15 V Transition

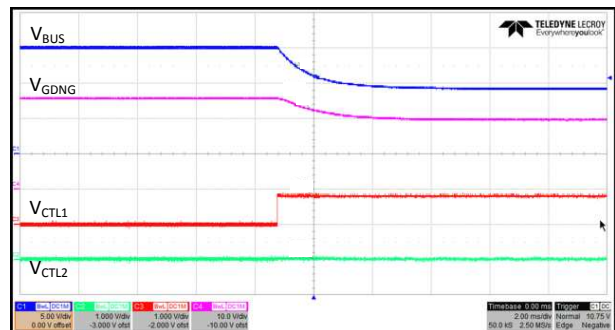

No Load

Figure 64. VBUS 15 V – 9 V Transition

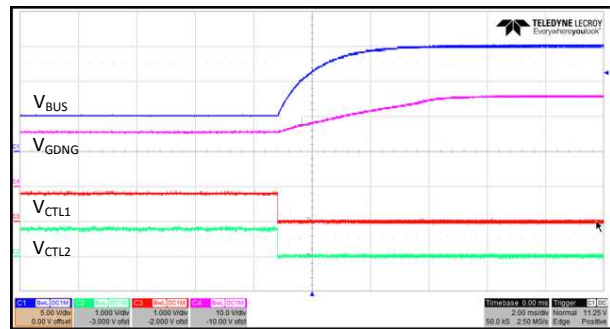

No Load

Figure 65. VBUS 5 V – 15 V Transition

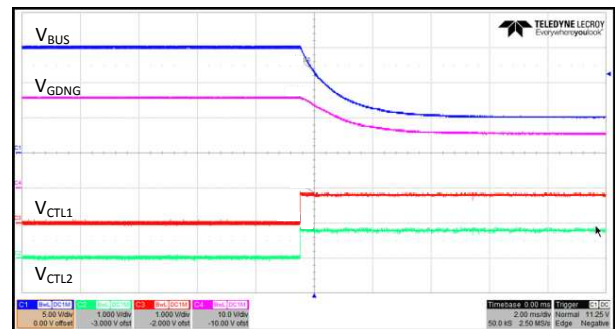

No Load

Figure 66. VBUS 15 V – 5 V Transition

9.3 System Examples

9.3.1 D/C Power Source (Power Hub)

In this system design example, the $P_{(SEL)}$ is configured such that $P_{(SEL)} = 93\text{ W}$, so 5 V, 9 V, and 15 V are offered at a maximum of 5 A, while 20 V is offered at a maximum of 4.64 A. The over-current protection (OCP) trip point is set just above 5 A.

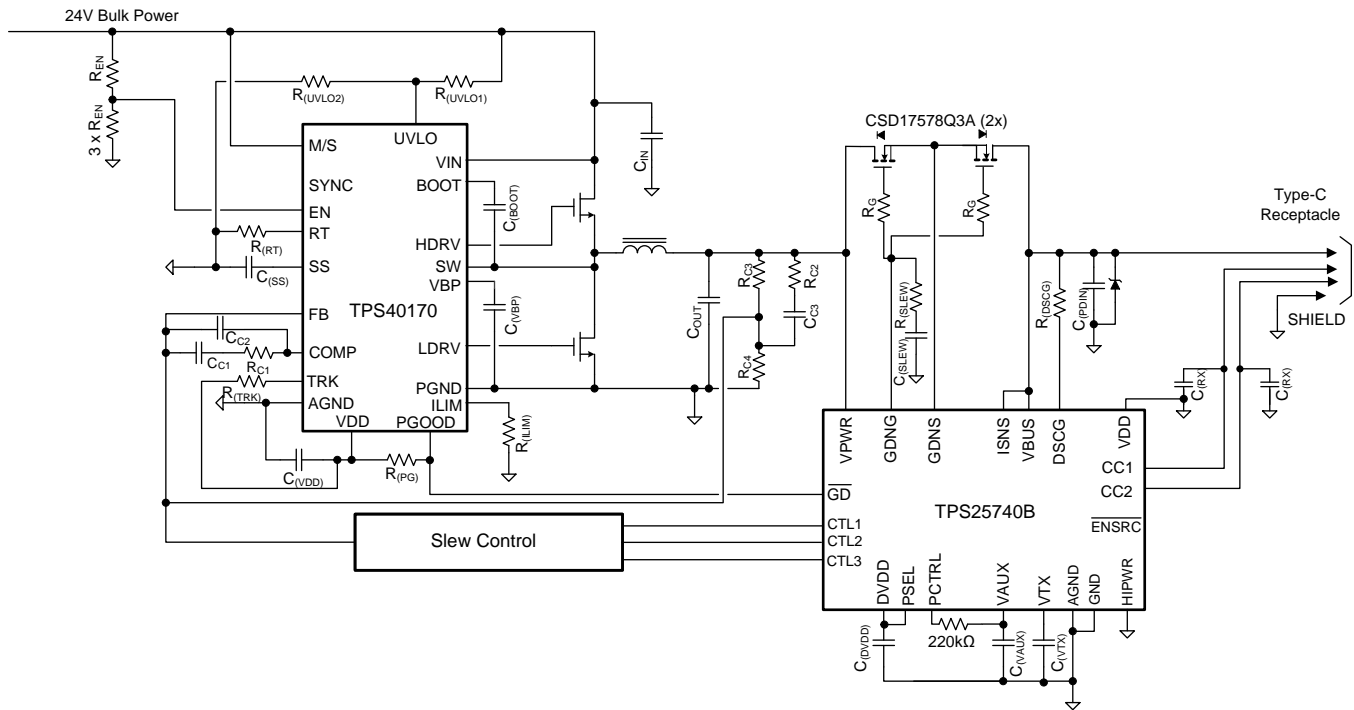

Copyright © 2016, Texas Instruments Incorporated

Figure 67. Power Hub Concept (Provider only)

This power hub circuit takes a 24 V input and produces a regulated output voltage. The over-current protection feature in the TPS25740B is not used; the ISNS and VBUS pins are connected directly. Instead $R_{(LIM)}$ is chosen to set the current limit of the TPS40170 synchronous PWM buck controller. If the current limit trips, the \overline{GD} pin of the TPS25740B is pulled low by the PGOOD pin of the TPS40170, which causes the power-path switch to be opened. Other fault conditions may also pull PGOOD low, but the slew rate of the voltage transition should be controlled as in one of the examples given above (Figure 44, Figure 45, or Figure 47).

VDD on the TPS25740B is grounded, if there is a suitable power supply available in the system the TPS25740B operates more efficiently if it is connected to VDD since $V_{(VPWR)} > V_{(VDD)}$. See Figure 70 for an example.

System Examples (continued)

9.3.2 A/C Power Source (Wall Adapter)

In this system design example, the PSEL pin is configured such that $P_{(SEL)} = 36\text{ W}$, and 5 V, 9 V are offered at a maximum of 3 A while 15 V is offered at a maximum of 2.4 A and 20 V is offered at a maximum of 1.8A. The overcurrent protection (OCP) trip point is set just above 3 A. VDD on the TPS25740B is grounded, if there is a suitable power supply available in the system the TPS25740B operates more efficiently if it is connected to VDD since $V_{(VPWR)} > V_{(VDD)}$.

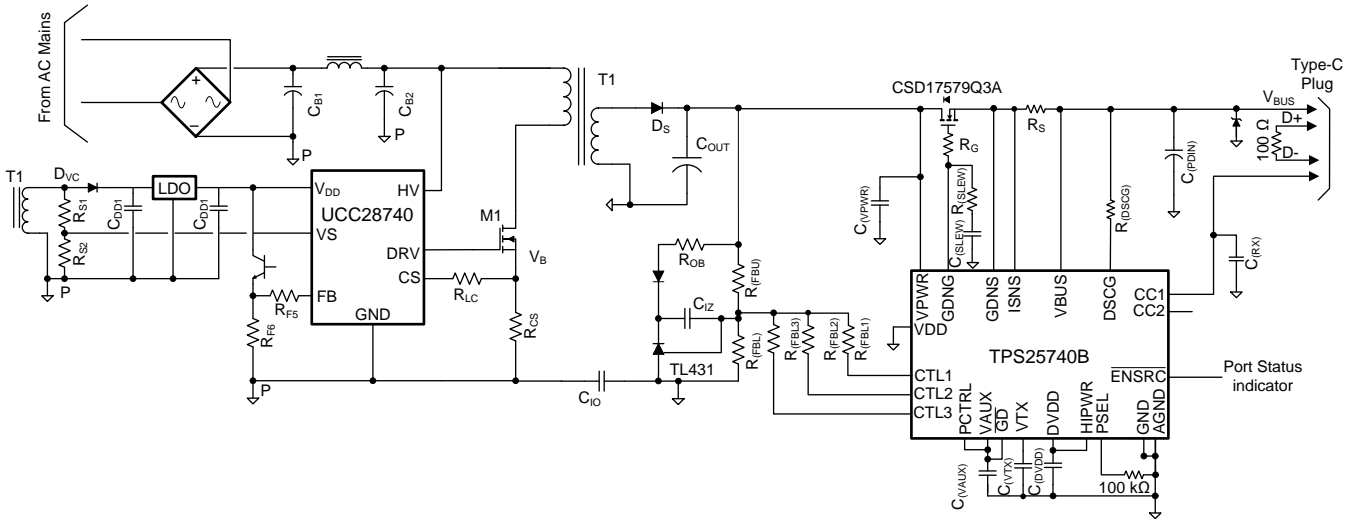

Copyright © 2016, Texas Instruments Incorporated

Figure 68. Adapter Provider Concept

System Examples (continued)

9.3.3 Dual-Port A/C Power Source (Wall Adaptor)

In this system design example, the PSEL pin is configured such that $P_{(SEL)} = 36\text{ W}$, and 5 V, 9 V, 12 V are offered at a maximum of 3 A while 15 V is offered at a maximum of 2.4A. The over-current protection (OCP) trip point is set just above 3 A.

The $\overline{\text{ENSRC}}$ pin from one TPS25740B is attached to the PCTRL pin on the other TPS25740B. When one port is not active (no UFP attached through the receptacle) its $\overline{\text{ENSRC}}$ pin is left high-z so the PCTRL pin on the other port is pulled high. This allows the adaptor to provide up to the full 36 W on a single port if a single UFP is attached. If two UFP's are attached (one to each port) then each port only offers current that would reach a maximum of 18 W. So each port is allocated half of the overall power when each port has a UFP attached.

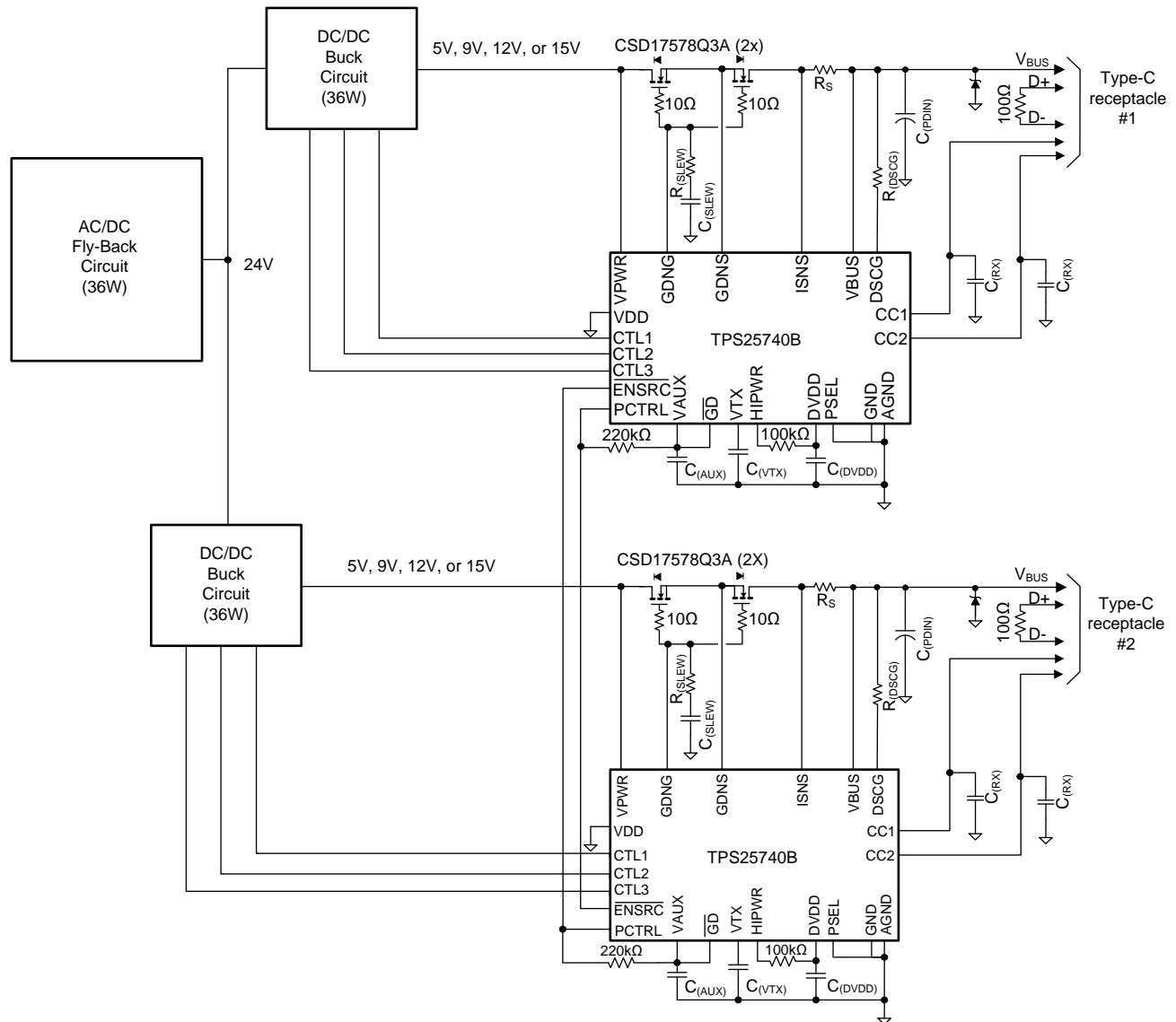

Copyright © 2016, Texas Instruments Incorporated

Figure 69. Dual-Port Adapter Provider Concept

System Examples (continued)

9.3.4 D/C Power Source (Power Hub with 3.3 V Rail)

In Figure 70, an LDO that outputs at least $I_{(SUPP)}$ at 3.3 V or 5 V is added to the power hub concept, and the DVDD pin is used to enable the buck regulator since it is active high. This implementation is more power efficient than the one in Figure 67.

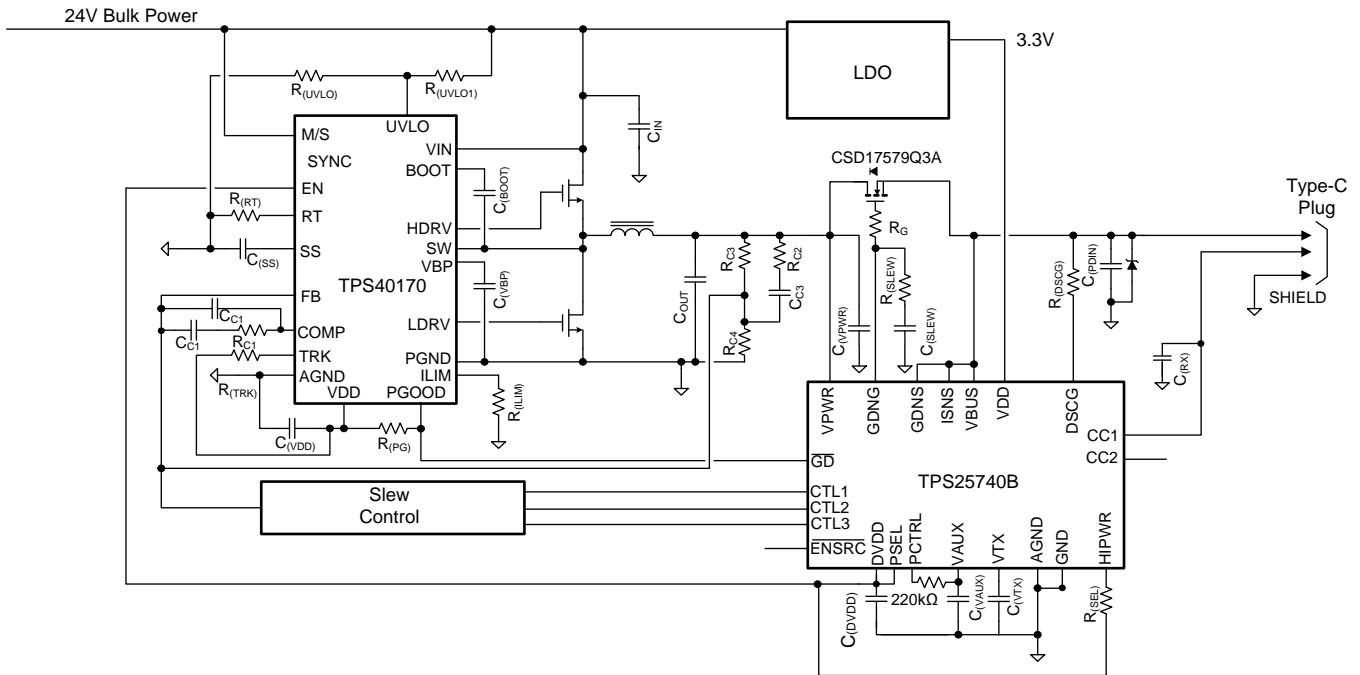

Copyright © 2016, Texas Instruments Incorporated

Figure 70. Power Hub Concept (Provider only)

10 Power Supply Recommendations

10.1 VDD

The recommended VDD supply voltage range is 3 V to 5.5 V. The device requires approximately 2 mA ($I_{(SUPP)}$) typical in normal operating mode and below 10 μ A in sleep mode. If the VDD supply is not used, then it may be connected to AGND/GND.

10.2 VPWR

The recommended VPWR supply voltage range is 0 V to 25 V. The device requires approximately 2 mA ($I_{(SUPP)}$) typical in normal operating mode and below 10 μ A in sleep mode.

11 Layout

11.1 Port Current Kelvin Sensing

Figure 71 provides a routing example for accurate current sensing for the overcurrent protection feature. The sense amplifier measurement occurs between the ISNS and VBUS pins of the device. Improper connection of these pins can result in poor OCP performance.

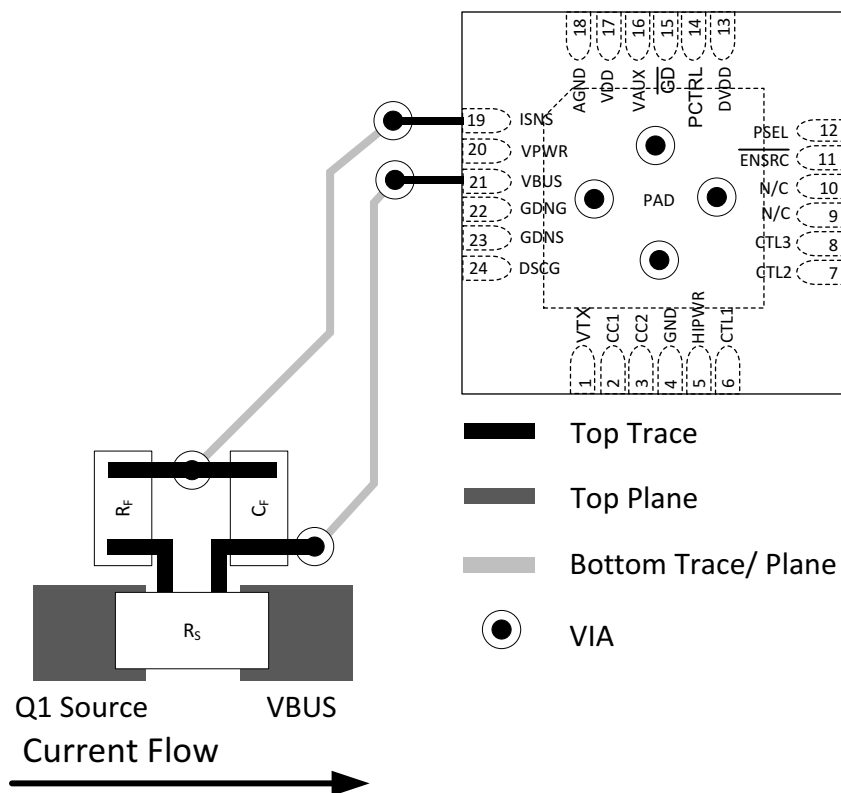

Figure 71. Kelvin Sense Layout Example

11.2 Layout Guidelines

11.2.1 Power Pin Bypass Capacitors

- $C_{(VPWR)}$: Place close to pin 20 (VPWR) and connect with low inductance traces and vias according to Figure 72.
- $C_{(VDD)}$: Place close to pin 17 (VDD) and connect with low inductance traces and vias according to Figure 72.
- $C_{(DVDD)}$: Place close to pin 13 (DVDD) and connect with low inductance traces and vias according to Figure 72.
- $C_{(VAUX)}$: Place close to pin 16 (VAUX) and connect with low inductance traces and vias according to Figure 72.
- $C_{(VTX)}$: Place close to pin 1 (VTX) and connect with low inductance traces and vias according to Figure 72.

11.2.2 Supporting Components

- $C_{(RX)}$: Place $C_{(RX1)}$ and $C_{(RX2)}$ in line with the CC1 and CC2 traces as shown in Figure 25. These should be placed within one inch from the Type C connector. Minimize stubs and tees from on the trace routes.
- Q_1 : Place Q_1 in a manner such that power flows uninterrupted from Q_1 drain to the Type C connector VBUS connections. Provide adequate copper plane from Q_1 drain and source to the interconnecting circuits.
- R_S : Place R_S as shown in Figure 72 to facilitate uninterrupted power flow to the Type C connector. Orient R_S for optimal Kelvin sense connection/routing back to the TPS25740B. In high current applications where the

Layout Guidelines (continued)

- power dissipation is over 250 mW, provide an adequate copper feed to the pads of R_S .
- R_G : Place R_G near Q_1 as shown in Figure 72. Minimize stray leakage paths as the GDNG sourcing current could be affected.
- $R_{(SLEW)}/C_{(SLEW)}$: Place $R_{(SLEW)}$ and $C_{(SLEW)}$ near R_G as shown in Figure 72.
- $R_{(DSCG)}$: Place on top of the VBUS copper route and connect to the DSCG pin with a 15 mil trace.
- R_F/C_F : When required, place R_F and C_F as shown in Figure 72 to facilitate the Kelvin sense connection back to the device.
- $C_{(VBUS)}/D_{(VBUS)}$: Place $C_{(VBUS)}$ and $D_{(VBUS)}$ within one inch of the Type C connector and connect them to VBUS and GND using adequate copper shapes.
- $R_{(SEL)}/R_{(PCTRL)}$: Place $R_{(SEL)}$ and $R_{(PCTRL)}$ near the device.

11.3 Layout Example

The basic component placement and layout is provided in Figure 72. This layout represents the circuit shown in Figure 38. The layout for other power configurations will vary slightly from that shown below.

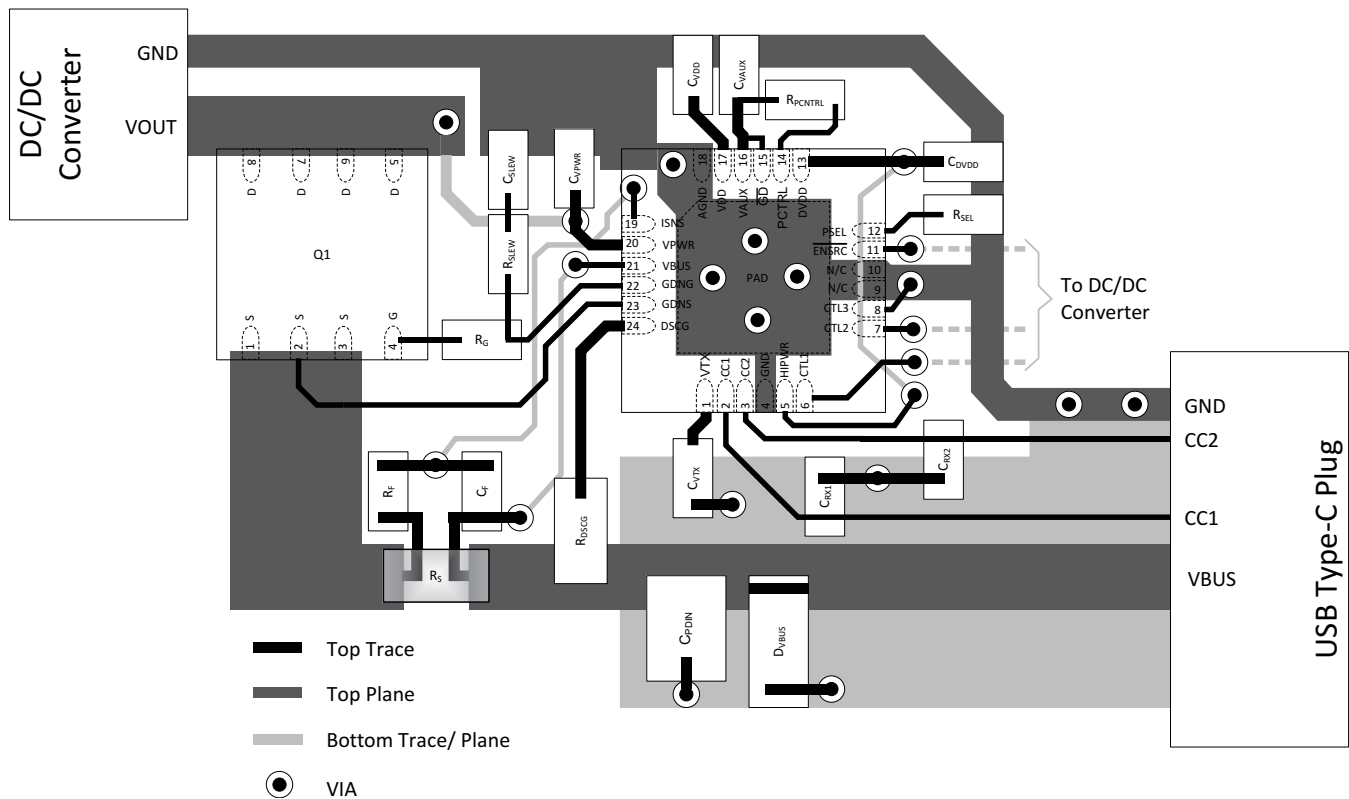

Figure 72. Example Layout

12 器件和文档支持

12.1 文档支持

有关 USB PD 和 USB Type-C 规范，请访问：<http://www.usb.org/home>

《TPS25740BEVM-741 EVM 用户指南》

《TPS25740B 设计计算器工具》

12.2 接收文档更新通知

要接收文档更新通知，请导航至 TI.com.cn 上的器件产品文件夹。单击右上角的 *通知我* 进行注册，即可每周接收产品信息更改摘要。有关更改的详细信息，请查看任何已修订文档中包含的修订历史记录。

12.3 社区资源

下列链接提供到 TI 社区资源的连接。链接的内容由各个分销商“按照原样”提供。这些内容并不构成 TI 技术规范，并且不一定反映 TI 的观点；请参阅 TI 的《使用条款》。

TI E2E™ 在线社区 *TI 的工程师对工程师 (E2E) 社区*。此社区的创建目的在于促进工程师之间的协作。在 e2e.ti.com 中，您可以咨询问题、分享知识、拓展思路并与同行工程师一道帮助解决问题。

设计支持 *TI 参考设计支持* 可帮助您快速查找有帮助的 E2E 论坛、设计支持工具以及技术支持的联系信息。

12.4 商标

E2E is a trademark of Texas Instruments.

Type-C is a trademark of USB Implementers Forum.

12.5 静电放电警告



这些装置包含有限的内置 ESD 保护。存储或装卸时，应将导线一起截短或将装置放置于导电泡棉中，以防止 MOS 门极遭受静电损伤。

12.6 术语表

SLYZ022 — *TI 术语表*。

这份术语表列出并解释术语、缩写和定义。

13 机械、封装和可订购信息

以下页面包含机械、封装和可订购信息。这些信息是指定器件的最新可用数据。数据如有变更，恕不另行通知，且不会对此文档进行修订。如需获取此产品说明书的浏览器版本，请查阅左侧的导航栏。

PACKAGING INFORMATION

Orderable Device	Status (1)	Package Type	Package Drawing	Pins	Package Qty	Eco Plan (2)	Lead finish/ Ball material (6)	MSL Peak Temp (3)	Op Temp (°C)	Device Marking (4/5)	Samples
TPS25740BRGER	NRND	VQFN	RGE	24	3000	RoHS & Green	NIPDAU	Level-1-260C-UNLIM	-40 to 125	TPS 25740B	
TPS25740BRGET	NRND	VQFN	RGE	24	250	RoHS & Green	NIPDAU	Level-1-260C-UNLIM	-40 to 125	TPS 25740B	

(1) The marketing status values are defined as follows:

ACTIVE: Product device recommended for new designs.

LIFEBUY: TI has announced that the device will be discontinued, and a lifetime-buy period is in effect.

NRND: Not recommended for new designs. Device is in production to support existing customers, but TI does not recommend using this part in a new design.

PREVIEW: Device has been announced but is not in production. Samples may or may not be available.

OBSOLETE: TI has discontinued the production of the device.

(2) **RoHS:** TI defines "RoHS" to mean semiconductor products that are compliant with the current EU RoHS requirements for all 10 RoHS substances, including the requirement that RoHS substance do not exceed 0.1% by weight in homogeneous materials. Where designed to be soldered at high temperatures, "RoHS" products are suitable for use in specified lead-free processes. TI may reference these types of products as "Pb-Free".

RoHS Exempt: TI defines "RoHS Exempt" to mean products that contain lead but are compliant with EU RoHS pursuant to a specific EU RoHS exemption.

Green: TI defines "Green" to mean the content of Chlorine (Cl) and Bromine (Br) based flame retardants meet JS709B low halogen requirements of <=1000ppm threshold. Antimony trioxide based flame retardants must also meet the <=1000ppm threshold requirement.

(3) MSL, Peak Temp. - The Moisture Sensitivity Level rating according to the JEDEC industry standard classifications, and peak solder temperature.

(4) There may be additional marking, which relates to the logo, the lot trace code information, or the environmental category on the device.

(5) Multiple Device Markings will be inside parentheses. Only one Device Marking contained in parentheses and separated by a "~" will appear on a device. If a line is indented then it is a continuation of the previous line and the two combined represent the entire Device Marking for that device.

(6) Lead finish/Ball material - Orderable Devices may have multiple material finish options. Finish options are separated by a vertical ruled line. Lead finish/Ball material values may wrap to two lines if the finish value exceeds the maximum column width.

Important Information and Disclaimer:The information provided on this page represents TI's knowledge and belief as of the date that it is provided. TI bases its knowledge and belief on information provided by third parties, and makes no representation or warranty as to the accuracy of such information. Efforts are underway to better integrate information from third parties. TI has taken and continues to take reasonable steps to provide representative and accurate information but may not have conducted destructive testing or chemical analysis on incoming materials and chemicals. TI and TI suppliers consider certain information to be proprietary, and thus CAS numbers and other limited information may not be available for release.

In no event shall TI's liability arising out of such information exceed the total purchase price of the TI part(s) at issue in this document sold by TI to Customer on an annual basis.

TAPE AND REEL INFORMATION



QUADRANT ASSIGNMENTS FOR PIN 1 ORIENTATION IN TAPE



*All dimensions are nominal

Device	Package Type	Package Drawing	Pins	SPQ	Reel Diameter (mm)	Reel Width W1 (mm)	A0 (mm)	B0 (mm)	K0 (mm)	P1 (mm)	W (mm)	Pin1 Quadrant
TPS25740BRGER	VQFN	RGE	24	3000	330.0	12.4	4.25	4.25	1.15	8.0	12.0	Q2
TPS25740BRGET	VQFN	RGE	24	250	180.0	12.4	4.25	4.25	1.15	8.0	12.0	Q2

TAPE AND REEL BOX DIMENSIONS

*All dimensions are nominal

Device	Package Type	Package Drawing	Pins	SPQ	Length (mm)	Width (mm)	Height (mm)
TPS25740BRGER	VQFN	RGE	24	3000	367.0	367.0	35.0
TPS25740BRGET	VQFN	RGE	24	250	210.0	185.0	35.0

RGE 24

GENERIC PACKAGE VIEW

VQFN - 1 mm max height

PLASTIC QUAD FLATPACK - NO LEAD



Images above are just a representation of the package family, actual package may vary.
Refer to the product data sheet for package details.

4204104/H

RGE0024H

PACKAGE OUTLINE

VQFN - 1 mm max height

PLASTIC QUAD FLATPACK- NO LEAD

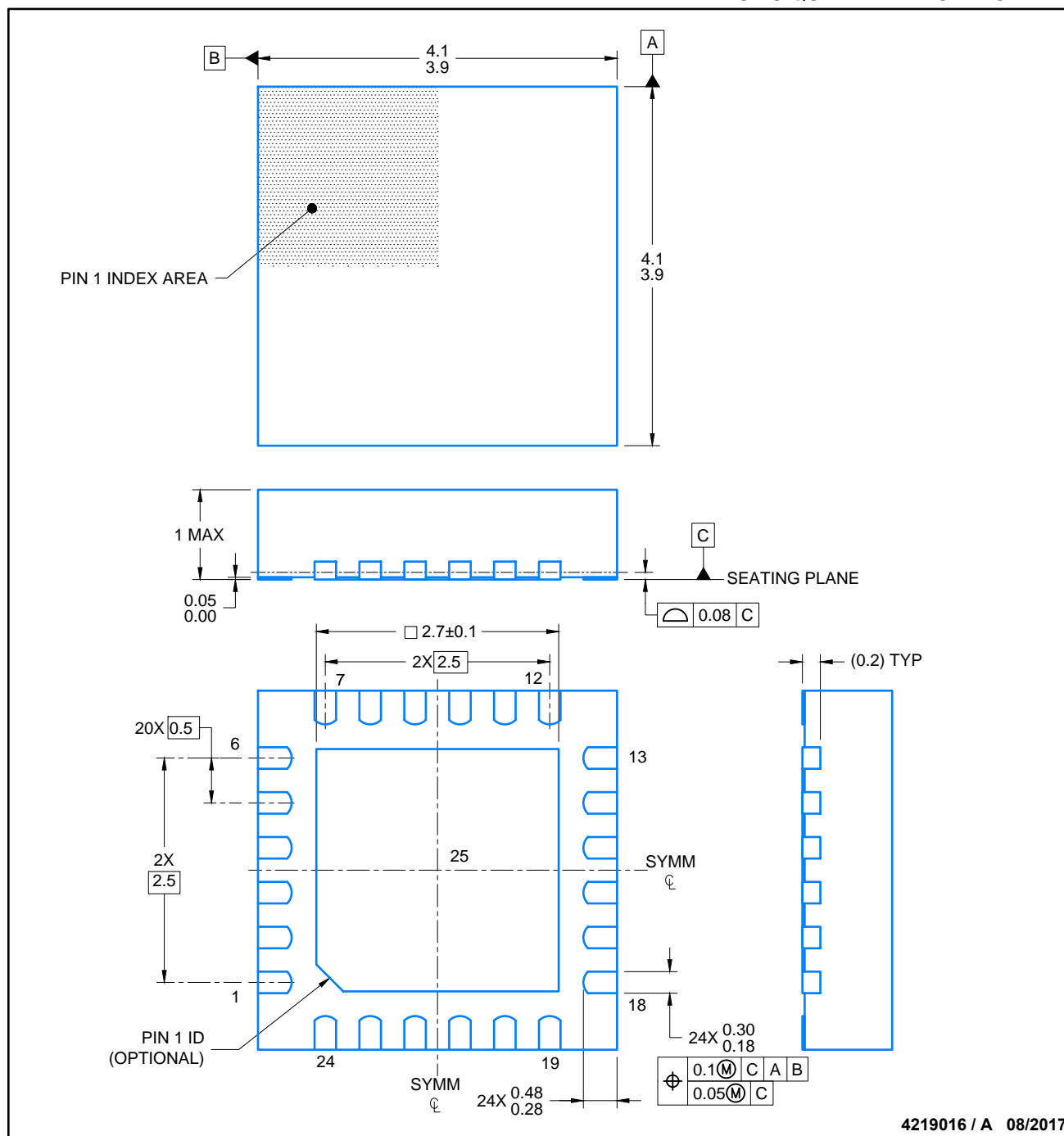

4219016 / A 08/2017

NOTES:

1. All linear dimensions are in millimeters. Any dimensions in parenthesis are for reference only. Dimensioning and tolerancing per ASME Y14.5M.
2. This drawing is subject to change without notice.
3. The package thermal pad must be soldered to the printed circuit board for thermal and mechanical performance.

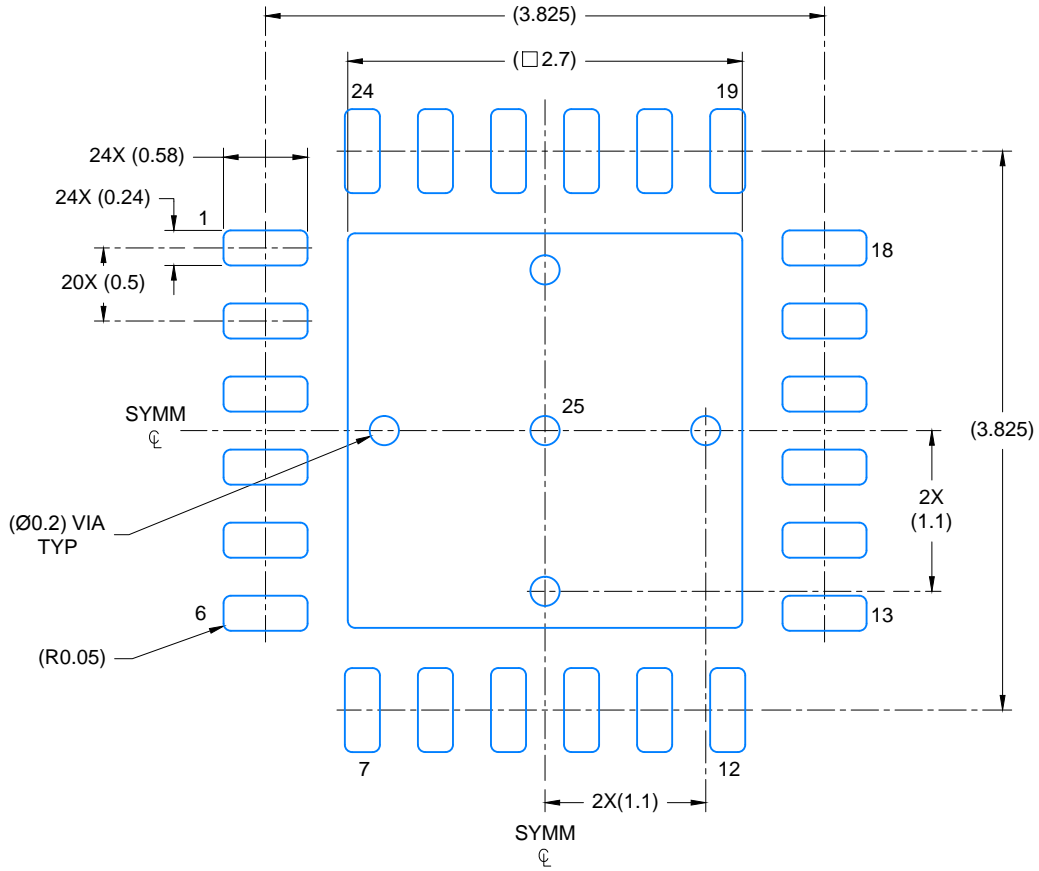

LAND PATTERN EXAMPLE
SCALE: 20X



4219016 / A 08/2017

NOTES: (continued)

4. This package is designed to be soldered to a thermal pad on the board. For more information, see Texas Instruments literature number SLUA271 (www.ti.com/lit/slua271).
5. Solder mask tolerances between and around signal pads can vary based on board fabrication site.

EXAMPLE STENCIL DESIGN

VQFN - 1 mm max height

RGE0024H

PLASTIC QUAD FLATPACK- NO LEAD

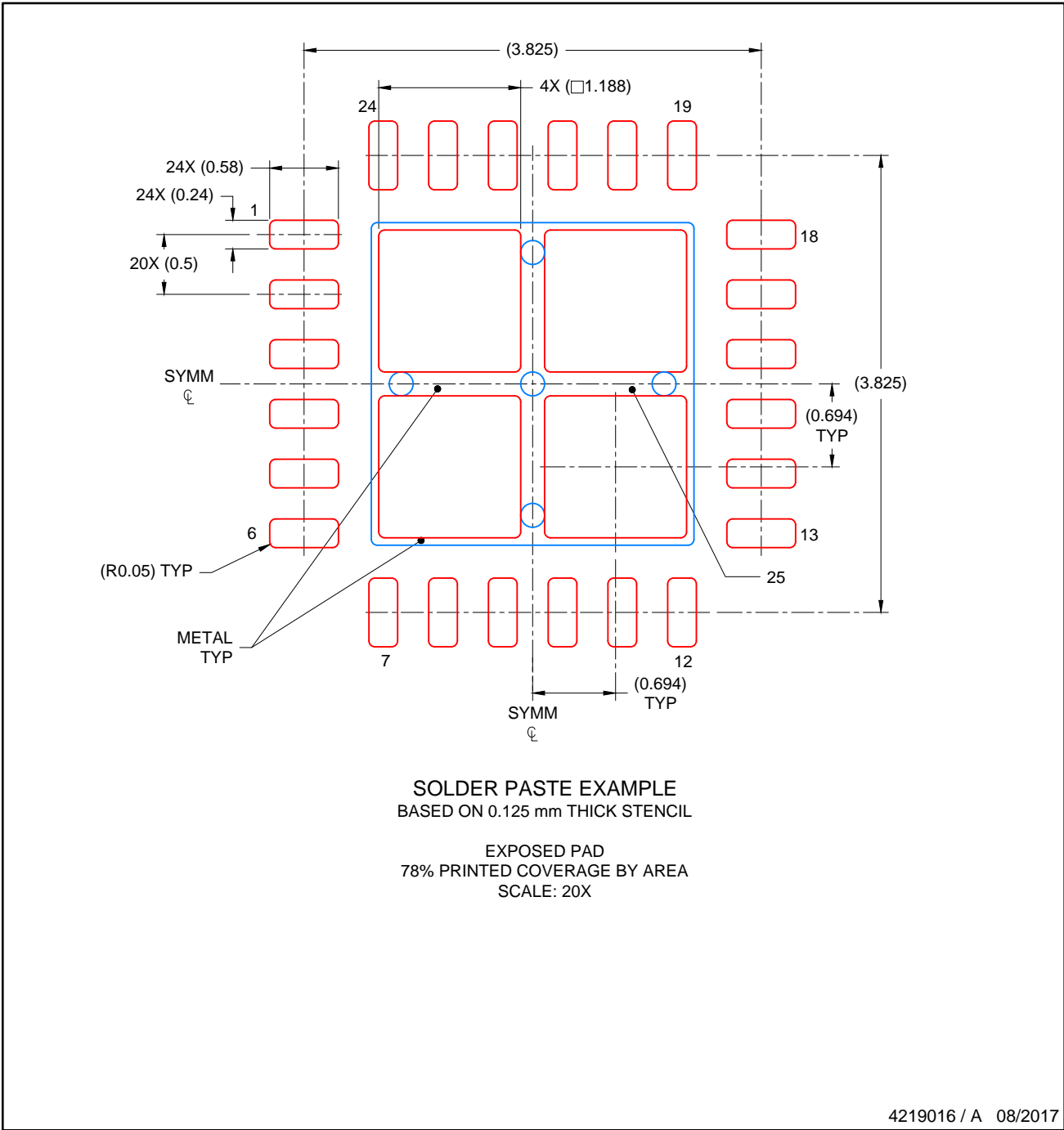

4219016 / A 08/2017

NOTES: (continued)

- 6. Laser cutting apertures with trapezoidal walls and rounded corners may offer better paste release. IPC-7525 may have alternate design recommendations..

重要声明和免责声明

TI 提供技术和可靠性数据（包括数据表）、设计资源（包括参考设计）、应用或其他设计建议、网络工具、安全信息和其他资源，不保证没有瑕疵且不做任何明示或暗示的担保，包括但不限于对适销性、某特定用途方面的适用性或不侵犯任何第三方知识产权的暗示担保。

这些资源可供使用 TI 产品进行设计的熟练开发人员使用。您将自行承担以下全部责任：(1) 针对您的应用选择合适的 TI 产品，(2) 设计、验证并测试您的应用，(3) 确保您的应用满足相应标准以及任何其他安全、安保或其他要求。这些资源如有变更，恕不另行通知。TI 授权您仅可将这些资源用于研发本资源所述的 TI 产品的应用。严禁对这些资源进行其他复制或展示。您无权使用任何其他 TI 知识产权或任何第三方知识产权。您应全额赔偿因在这些资源的使用中对 TI 及其代表造成的任何索赔、损害、成本、损失和债务，TI 对此概不负责。

TI 提供的产品受 TI 的销售条款 (<https://www.ti.com.cn/zh-cn/legal/termsofsale.html>) 或 [ti.com.cn](https://www.ti.com.cn) 上其他适用条款/TI 产品随附的其他适用条款的约束。TI 提供这些资源并不会扩展或以其他方式更改 TI 针对 TI 产品发布的适用的担保或担保免责声明。

邮寄地址：上海市浦东新区世纪大道 1568 号中建大厦 32 楼，邮政编码：200122

Copyright © 2021 德州仪器半导体技术（上海）有限公司