

## 带有 DCS™ 控制的 3A 高效同步降压转换器

 查询样品: [TPS62090](#), [TPS62091](#), [TPS62092](#), [TPS62093](#)

### 特性

- 2.5 V 至 6 V 输入电压范围
- DCS™ 控制
- 转换器效率 95%
- 省电模式
- 20  $\mu$ A 运行静态电流
- 针对最低压降的 100% 占空比
- 2.8 MHz/1.4 MHz 典型开关频率
- 0.8 V 至  $V_{IN}$  的可调输出电压
- 固定输出电压版本
- 输出放电功能
- 可调节软启动
- 两级短路保护
- 输出电压跟踪
- 宽输出电容值选择
- 采用 3mm x 3mm 16 引脚四方扁平无引线 (QFN) 封装

### 应用

- 分布式电源
- 笔记本、笔记本电脑
- 硬盘驱动器
- 处理器电源
- 电池供电型应用

### 说明

TPS6209x 器件是一款高效同步降压转换器，此转换器针对小外形尺寸、高效应用进行了优化并适合于电池供电类应用。为了最大限度地提升效率，此转换器运行在 2.8 MHz/1.4 MHz 的标称开关频率的脉宽调制 (PWM) 模式下并在轻负载时自动进入省电运行模式。当被用于分布式电源和负载点调制时，此器件允许到其它电源轨的电压跟踪并可耐受范围在 10  $\mu$ F 到高达 150  $\mu$ F 甚至更高的输出电容。通过使用 DCS™ 控制技术，此器件可实现出色的负载静态性能以及精确的输出电压调制。

此输出电压启动斜坡由软启动引脚控制，从而使器件可作为独立电源运行或运行在跟踪配置下。通过配置使能和开漏电源正常引脚也有可能实现电源排序。在省电模式下，此器件运行在典型值为 20  $\mu$ A 静态电流下。在全部负载电流范围内，自动进入省电模式并且无缝保持高效。

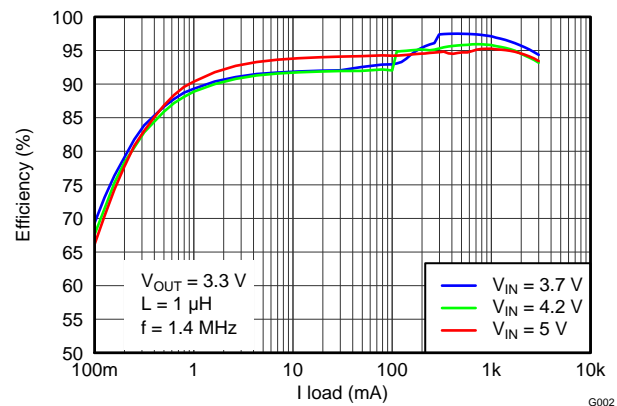
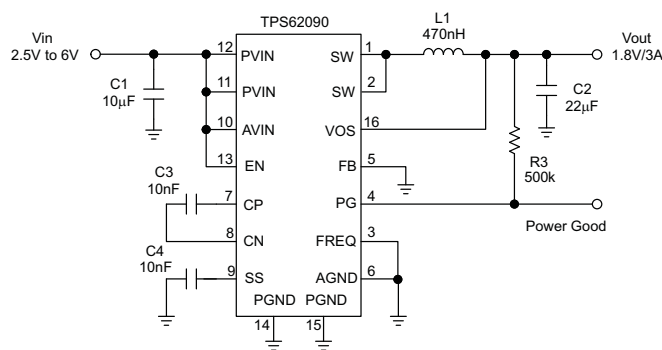

Please be aware that an important notice concerning availability, standard warranty, and use in critical applications of Texas Instruments semiconductor products and disclaimers thereto appears at the end of this data sheet.

All trademarks are the property of their respective owners.

PRODUCTION DATA information is current as of publication date. Products conform to specifications per the terms of the Texas Instruments standard warranty. Production processing does not necessarily include testing of all parameters.

Copyright © 2012, Texas Instruments Incorporated  
English Data Sheet: [SLVSAW2](#)



These devices have limited built-in ESD protection. The leads should be shorted together or the device placed in conductive foam during storage or handling to prevent electrostatic damage to the MOS gates.

### ORDERING INFORMATION<sup>(1)</sup>

T <sub>A</sub>	V <sub>OUT</sub>	ORDERING	PACKAGE	PACKAGE MARKING
-40°C to 85°C	adjustable	TPS62090	RGT	SBW
	3.3 V	TPS62091	RGT	SBX
	2.5 V	TPS62092	RGT	SBY
	1.8 V	TPS62093	RGT	SBZ

(1) For detailed ordering information please see the PACKAGE OPTION ADDENDUM section at the end of the datasheet.

### ABSOLUTE MAXIMUM RATINGS<sup>(1)</sup>

over operating free-air temperature range (unless otherwise noted)

		VALUE		UNIT
		MIN	MAX	
Voltage range	PVIN, AVIN, FB, SS, EN, FREQ, VOS <sup>(2)</sup>	-0.3	7	V
	SW, PG	-0.3	V <sub>IN</sub> +0.3	V
Power Good sink current	PG		1	mA
ESD rating	Human Body Model		2	kV
	Charged Device Model		500	V
Continuous total power dissipation	See the Thermal Table			
Operating junction temperature range, T <sub>J</sub>		-40	150	°C
Operating ambient temperature range, T <sub>A</sub>		-40	85	°C
Storage temperature range, T <sub>stg</sub>		-65	150	°C

- (1) Stresses beyond those listed under “absolute maximum ratings” may cause permanent damage to the device. These are stress ratings only and functional operation of the device at these or any other conditions beyond those indicated under “recommended operating conditions” is not implied. Exposure to absolute-maximum-rated conditions for extended periods may affect device reliability.
- (2) All voltage values are with respect to network ground terminal.

### THERMAL INFORMATION

THERMAL METRIC <sup>(1)</sup>		TPS62090	UNITS
		QFN (16 PINS)	
θ <sub>JA</sub>	Junction-to-ambient thermal resistance	47	°C/W
θ <sub>JCtop</sub>	Junction-to-case (top) thermal resistance	60	
θ <sub>JB</sub>	Junction-to-board thermal resistance	20	
ψ <sub>JT</sub>	Junction-to-top characterization parameter	1.5	
ψ <sub>JB</sub>	Junction-to-board characterization parameter	20	
θ <sub>JCbot</sub>	Junction-to-case (bottom) thermal resistance	5.3	

(1) For more information about traditional and new thermal metrics, see the *IC Package Thermal Metrics* application report, [SPRA953](#).

### RECOMMENDED OPERATING CONDITIONS<sup>(1)</sup>

		MIN	TYP	MAX	UNIT
V <sub>IN</sub>	Input voltage range V <sub>IN</sub>	2.5		6	V
T <sub>A</sub>	Operating ambient temperature	-40		85	°C
T <sub>J</sub>	Operating junction temperature	-40		125	°C

(1) See the application section for further information

## ELECTRICAL CHARACTERISTICS

 $V_{IN} = 3.6V$ ,  $T_A = -40^{\circ}C$  to  $85^{\circ}C$ , typical values are at  $T_A = 25^{\circ}C$  (unless otherwise noted)

PARAMETER		TEST CONDITIONS	MIN	TYP	MAX	UNIT
<b>SUPPLY</b>						
$V_{IN}$	Input voltage range		2.5		6	V
$I_{QIN}$	Quiescent current	Not switching, FB = FB +5 %, Into PVIN and AVIN		20		$\mu A$
$I_{sd}$	Shutdown current	Into PVIN and AVIN		0.6	5	$\mu A$
UVLO	Undervoltage lockout threshold	$V_{IN}$ falling	2.1	2.2	2.3	V
	Undervoltage lockout hysteresis			200		mV
	Thermal shutdown	Temperature rising		150		$^{\circ}C$
	Thermal shutdown hysteresis			20		$^{\circ}C$
<b>Control SIGNALS EN, FREQ</b>						
$V_H$	High level input voltage	$V_{IN} = 2.5 V$ to $6 V$	1			V
$V_L$	Low level input voltage	$V_{IN} = 2.5 V$ to $6 V$			0.4	V
$I_{lkg}$	Input leakage current	EN, FREQ = GND or $V_{IN}$		10	100	nA
$R_{PD}$	Pull down resistance			400		k $\Omega$
<b>Softstart</b>						
$I_{SS}$	Softstart current		6.3	7.5	8.7	$\mu A$
<b>POWER GOOD</b>						
$V_{th}$	Power good threshold	Output voltage rising		95%		
		Output voltage falling		90%		
$V_L$	Low level voltage	$I_{(sink)} = 1mA$			0.4	V
$I_{PG}$	PG sinking current				1	mA
$I_{lkg}$	Leakage current	$V_{PG} = 3.6V$		10	100	nA
<b>POWER SWITCH</b>						
$R_{DS(on)}$	High side FET on-resistance	$I_{SW} = 500 mA$		50		m $\Omega$
	Low side FET on-resistance	$I_{SW} = 500 mA$		40		m $\Omega$
$I_{LIM}$	High side FET switch current limit		3.7	4.6	5.5	A
$f_s$	Switching frequency	FREQ = GND, $I_{OUT} = 3 A$		2.8		MHz
		FREQ = VIN, $I_{OUT} = 3 A$		1.4		MHz
<b>OUTPUT</b>						
$V_s$	Output voltage range		0.8		$V_{IN}$	V
$R_{od}$	Output discharge resistor	EN = GND, $V_{OUT} = 1.8 V$		200		$\Omega$
$V_{FB}$	Feedback regulation voltage			0.8		V
$V_{FB}$	Feedback voltage accuracy <sup>(1) (2)(3)</sup>	$V_{IN} \geq V_{OUT} + 1 V$ , TPS62090 adjustable output version $I_{OUT} = 1 A$ , PWM mode	-1.4%		+1.4%	
		$I_{OUT} = 0 mA$ , FREQ = 2.8 MHz, $V_{OUT} \geq 0.8 V$ , PFM mode	-1.4%		+3%	
		$I_{OUT} = 0 mA$ , FREQ = 1.4 MHz, $V_{OUT} \geq 1.2 V$ , PFM mode	-1.4%		+3%	
		$I_{OUT} = 0 mA$ , FREQ = 1.4 MHz, $V_{OUT} < 1.2V$ , PFM mode	-1.4%		+3.7%	
$I_{FB}$	Feedback input bias current	$V_{FB} = 0.8V$ , TPS62090 adjustable output version		10	100	nA
$V_{OUT}$	Output voltage accuracy <sup>(2)(3)</sup>	$V_{IN} \geq V_{OUT} + 1 V$ , Fixed output voltage $I_{OUT} = 1 A$ , PWM mode	-1.4%		+1.4%	
		$I_{OUT} = 0 mA$ , FREQ = High and Low, PFM mode	-1.4%		+2.5%	
	Line regulation	$V_{OUT} = 1.8 V$ , PWM operation		0.016		%/V
	Load regulation	$V_{OUT} = 1.8 V$ , PWM operation		0.04		%/A

(1) For output voltages < 1.2 V, use a 2 x 22  $\mu F$  output capacitance to achieve +3% output voltage accuracy.

(2) Conditions:  $f = 2.8 MHz$ ,  $L = 0.47 \mu H$ ,  $C_{OUT} = 22 \mu F$  or  $f = 1.4 MHz$ ,  $L = 1 \mu H$ ,  $C_{OUT} = 22 \mu F$ .

(3) For more information, see the [Power Save Mode Operation](#) section of this data sheet.

## DEVICE INFORMATION

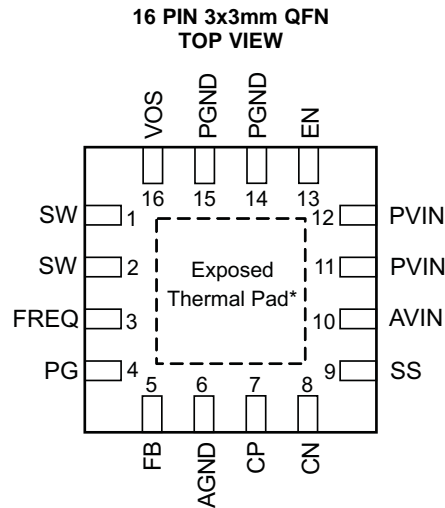

NOTE: \*The exposed Thermal Pad is connected to AGND.

## PIN FUNCTIONS

PIN		I/O	DESCRIPTION
NAME	NO.		
SW	1, 2	I	Switch pin of the power stage.
FREQ	3	I	This pin selects the switching frequency of the device. FREQ=low sets the typical switching frequency to 2.8 MHz. FREQ=high sets the typical switching frequency to 1.4 MHz. This pin has an active pull down resistor of typically 400 kΩ and can be left floating for 2.8 MHz operation.
PG	4	O	Power good open drain output. This pin is high impedance if the output voltage is within regulation. This pin is pulled low if the output is below its nominal value. The pull up resistor can not be connected to any voltage higher than the input voltage of the device.
FB	5		Feedback pin of the device. For the fixed output voltage versions this pin needs to be connected to GND for improved thermal performance. If, desired then this pin can also be left floating since it is internally connected with 400 kΩ to GND for fixed output voltage versions.
AGND	6		Analog ground.
CP	7		Internal charge pump flying capacitor. Connect a 10 nF capacitor between CP and CN.
CN	8		Internal charge pump flying capacitor. Connect a 10 nF capacitor between CP and CN.
SS	9	I	Soft-start control pin. A capacitor is connected to this pin and sets the softstart time. Leaving this pin floating sets the minimum start-up time.
AVIN	10		Bias supply input voltage pin.
PVIN	11,12		Power supply input voltage pin.
EN	13		Device enable. To enable the device this pin needs to be pulled high. Pulling this pin low disables the device. This pin has an active pull down resistor of typically 400 kΩ.
PGND	14,15		Power ground connection.
VOS	16		Output voltage sense pin. This pin needs to be connected to the output voltage.
Thermal Pad			The exposed thermal pad is connected to AGND.

FUNCTIONAL BLOCK DIAGRAM

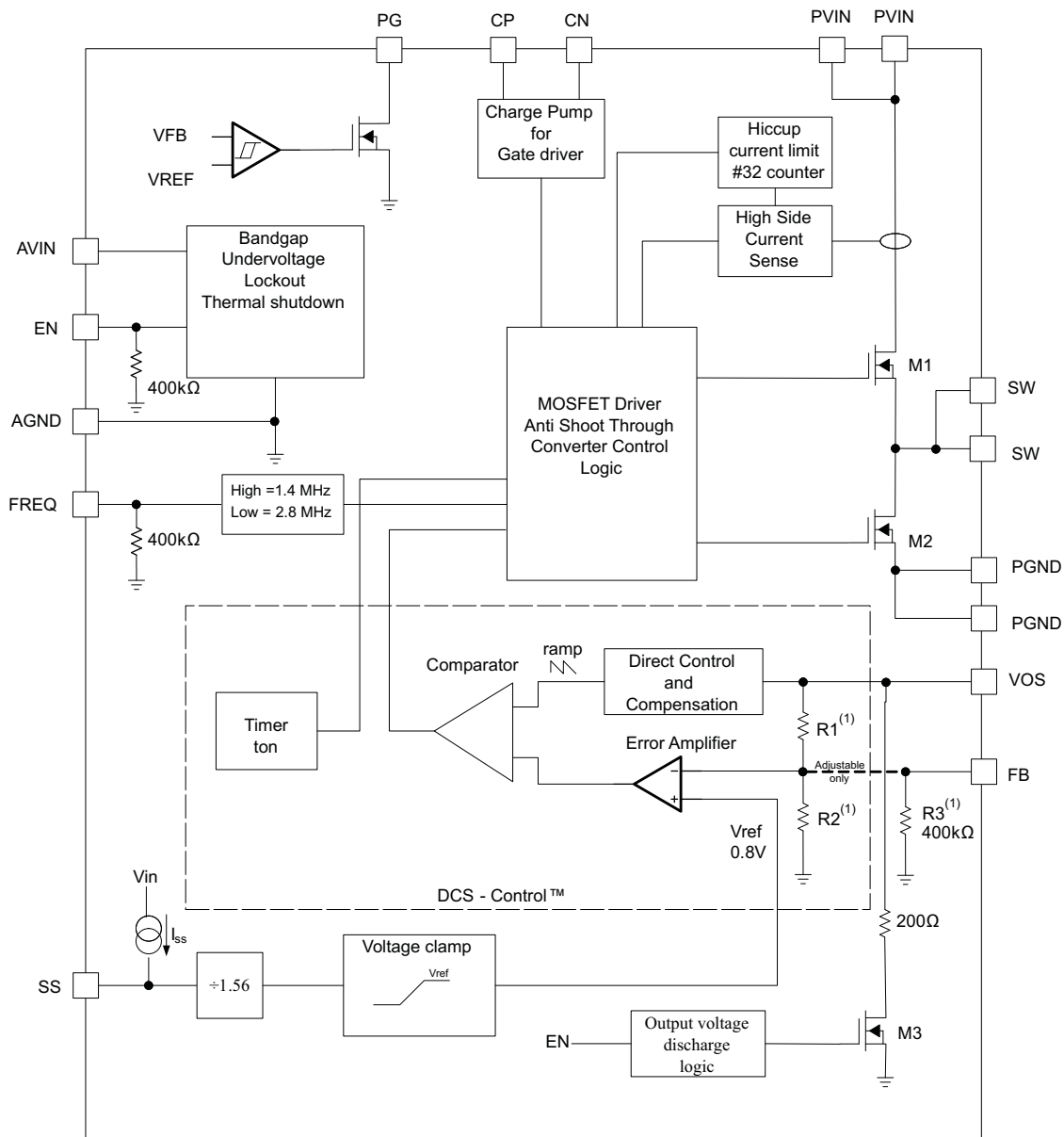

(1) R1, R2, R3 are implemented in the fixed output voltage version only.

**Table 1. List of components**

REFERENCE	DESCRIPTION	MANUFACTURER
TPS62090	High efficient step down converter	Texas Instruments
L1	Inductor: 1uH, 0.47uH, 0.4uH	Coilcraft XFL4020-102, XAL4020-401, TOKO DEF252012-R47
C1	Ceramic capacitor: 10uF, 22uF	(6.3V, X5R, 0603), (6.3V, X5R, 0805)
C2	Ceramic capacitor: 22uF	(6.3V, X5R, 0805)
C3, C4	Ceramic capacitor	Standard
R1, R2, R3	Resistor	Standard

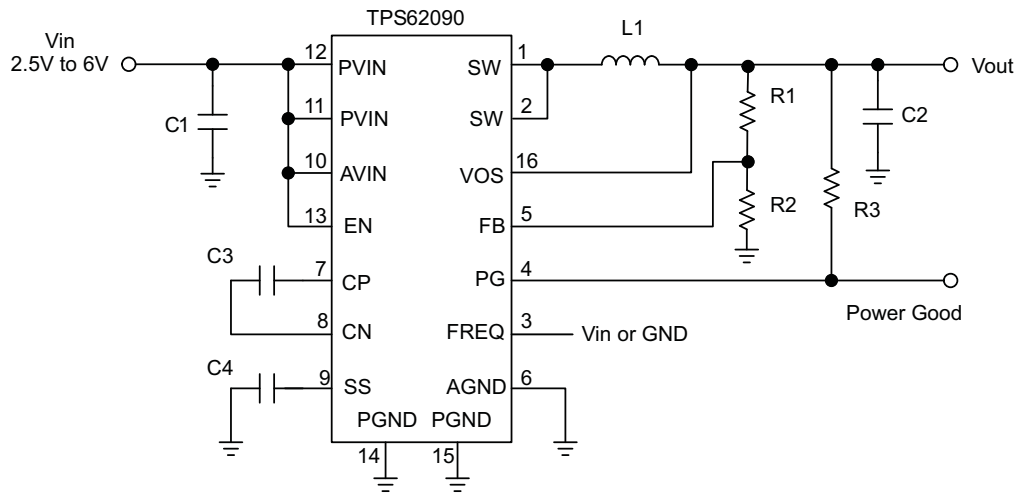

**Figure 1. Parametric Measurement Circuit**

TYPICAL CHARACTERISTICS

		FIGURE
Efficiency	vs load current ( $V_O = 3.3\text{ V}$ , $f = 1.4\text{ MHz}$ , $f = 2.8\text{ MHz}$ )	Figure 2, Figure 3
Efficiency	vs load current ( $V_O = 1.8\text{ V}$ , $f = 1.4\text{ MHz}$ , $f = 2.8\text{ MHz}$ )	Figure 4, Figure 5
Efficiency	vs load current ( $V_O = 1.05\text{ V}$ , $f = 1.4\text{ MHz}$ , $f = 2.8\text{ MHz}$ )	Figure 6, Figure 7
Output voltage	vs load current ( $V_O = 1.8\text{ V}$ , $f = 1.4\text{ MHz}$ , $f = 2.8\text{ MHz}$ )	Figure 8, Figure 9
High Side FET on-resistance	vs input voltage	Figure 10
Switching frequency	vs load current ( $V_O = 1.8\text{ V}$ , $f = 1.4\text{ MHz}$ )	Figure 11
Switching frequency	vs input voltage ( $V_O = 1.8\text{ V}$ , $f = 1.4\text{ MHz}$ )	Figure 12
Switching frequency	vs load current ( $V_O = 1.8\text{ V}$ , $f = 2.8\text{ MHz}$ )	Figure 13
Switching frequency	vs input voltage ( $V_O = 1.8\text{ V}$ , $f = 2.8\text{ MHz}$ )	Figure 14
Quiescent current	vs input voltage ( $V_O = 1.8\text{ V}$ , $f = 1.4\text{ MHz}$ )	Figure 15
PWM operation	$V_O = 1.8\text{ V}$ , $f = 1.4\text{ MHz}$	Figure 16
PFM operation	$V_O = 1.8\text{ V}$ , $f = 1.4\text{ MHz}$	Figure 17
PFM operation	$V_O = 1.8\text{ V}$ , $f = 2.8\text{ MHz}$	Figure 18
Load sweep	$V_O = 1.8\text{ V}$ , $f = 1.4\text{ MHz}$	Figure 19
Load sweep	$V_O = 1.8\text{ V}$ , $f = 2.8\text{ MHz}$	Figure 20
Start-up	$V_O = 1.8\text{ V}$ , $f = 2.8\text{ MHz}$ , $C_{SS} = 10\text{ nF}$	Figure 21
Shutdown	$V_O = 1.8\text{ V}$ , $f = 2.8\text{ MHz}$	Figure 22
Hiccup short circuit protection	$V_O = 1.8\text{ V}$ , $f = 1.4\text{ MHz}$	Figure 23
Hiccup Short circuit protection	$V_O = 1.8\text{ V}$ , $f = 1.4\text{ MHz}$ , recovery after short circuit	Figure 24
Load transient response	$V_O = 1.8\text{ V}$ , $f = 1.4\text{ MHz}$ , 300 mA to 2.5 A	Figure 25
Load transient response	$V_O = 1.8\text{ V}$ , $f = 1.4\text{ MHz}$ , 300 mA to 2.5 A	Figure 26
Load transient response	$V_O = 1.8\text{ V}$ , $f = 1.4\text{ MHz}$ , 20 mA to 1 A	Figure 27

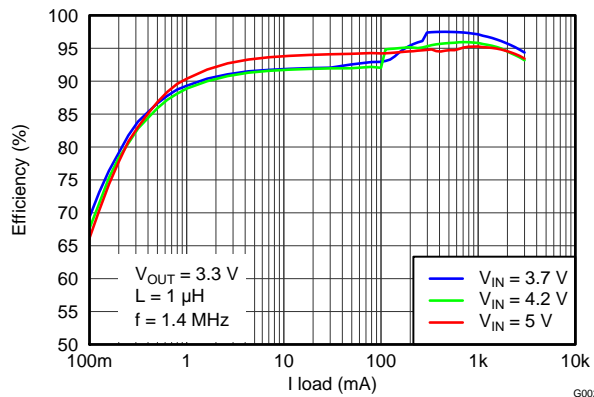

Figure 2. Efficiency vs Load Current

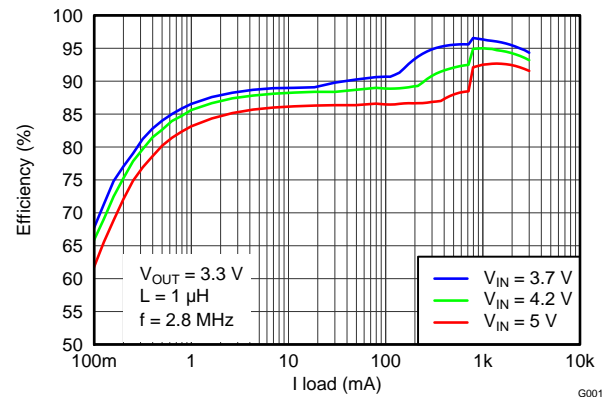

Figure 3. Efficiency vs Load Current

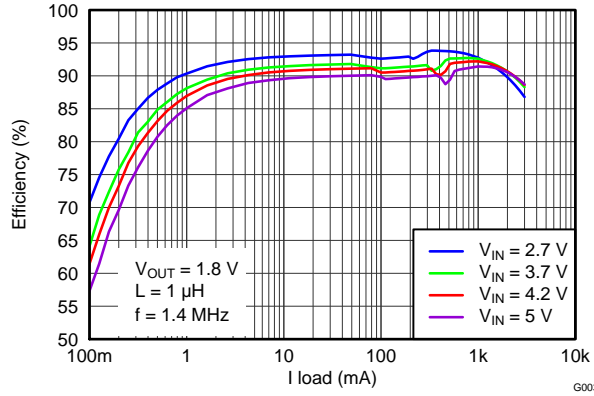

Figure 4. Efficiency vs Load Current

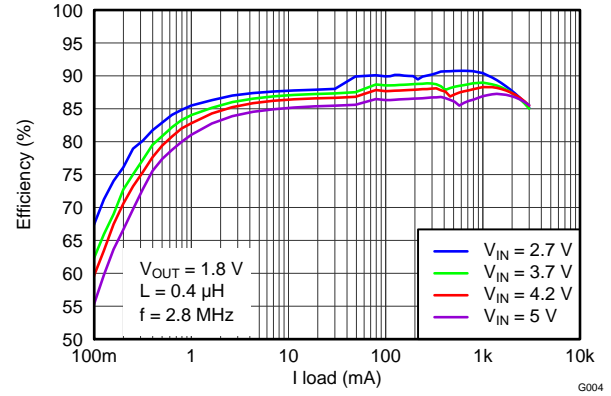

Figure 5. Efficiency vs Load Current

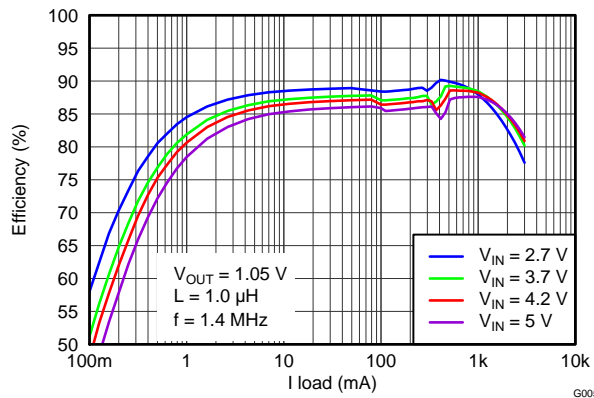

Figure 6. Efficiency vs Load Current

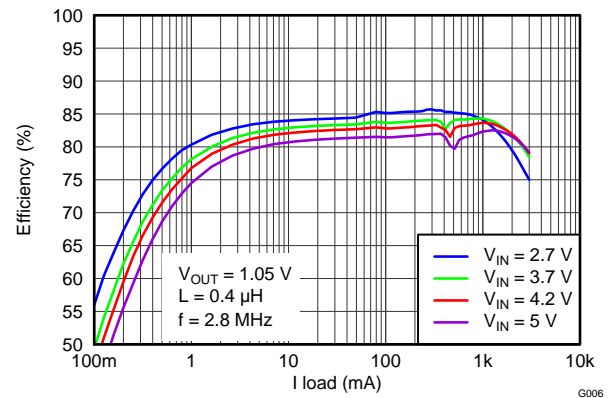

Figure 7. Efficiency vs Load Current

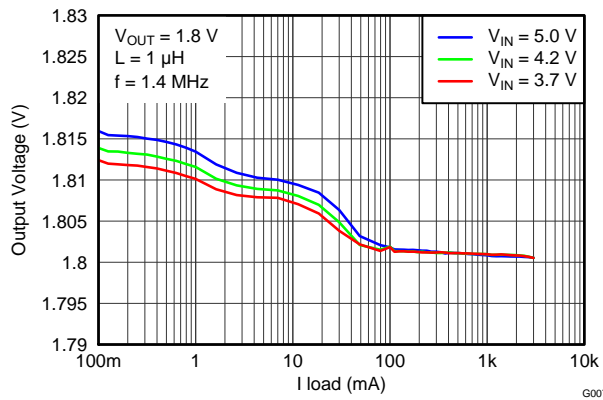

Figure 8. Output Voltage vs Load Current

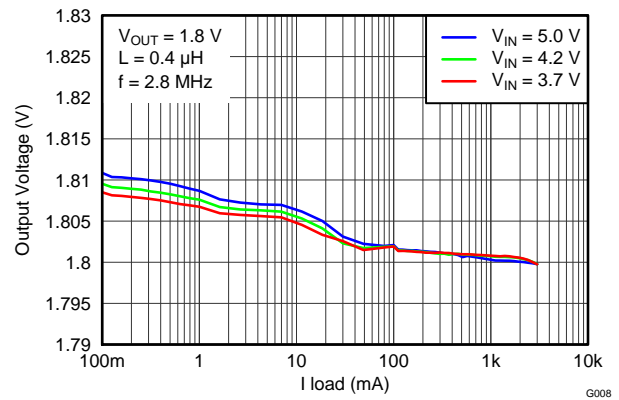

Figure 9. Output Voltage vs Load Current



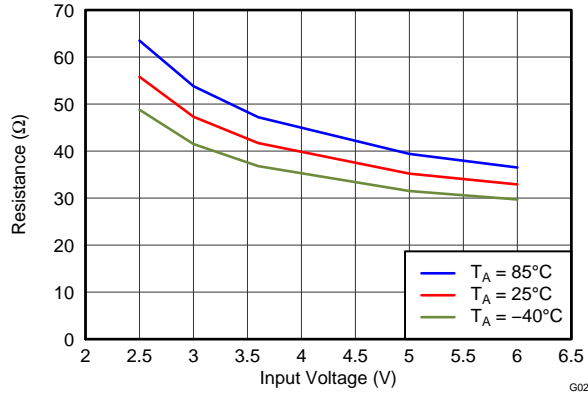

Figure 10. High Side FET On-Resistance vs Input Voltage

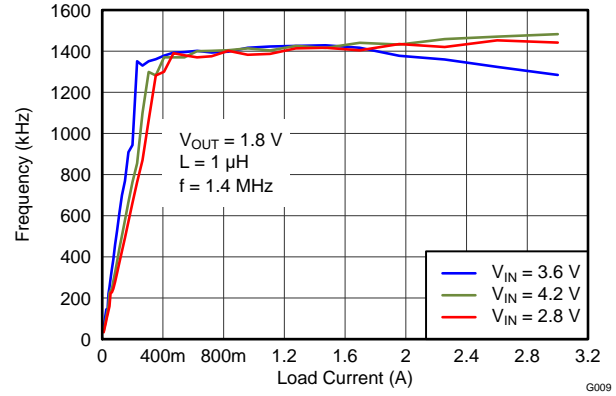

Figure 11. Switching Frequency vs Load Current

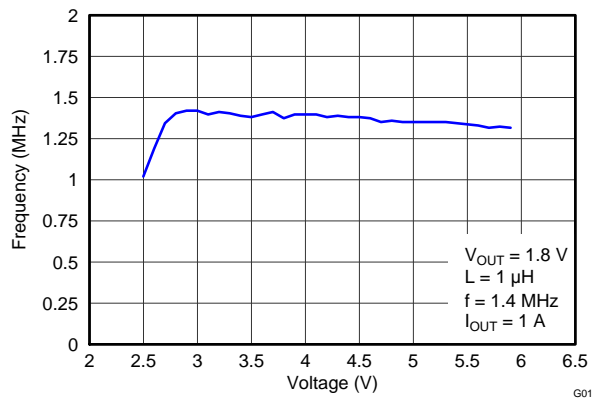

Figure 12. Switching Frequency vs Input Voltage

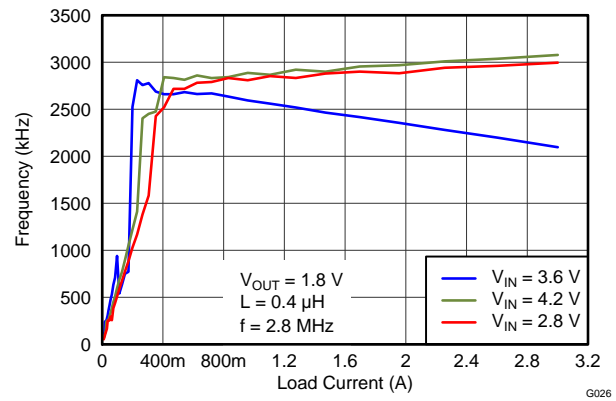

Figure 13. Frequency vs Load Current

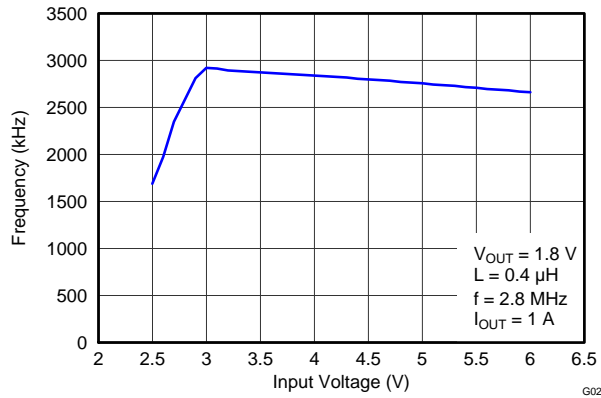

Figure 14. Frequency vs Input Voltage

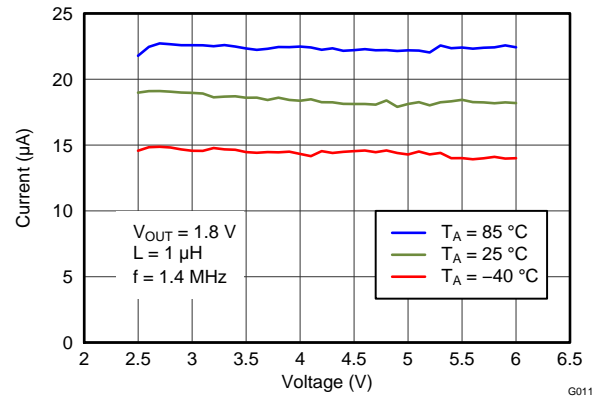

Figure 15. Quiescent Current vs Input Voltage

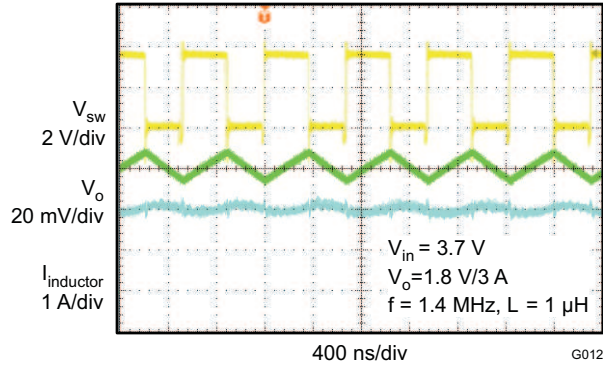

Figure 16. PWM Operation

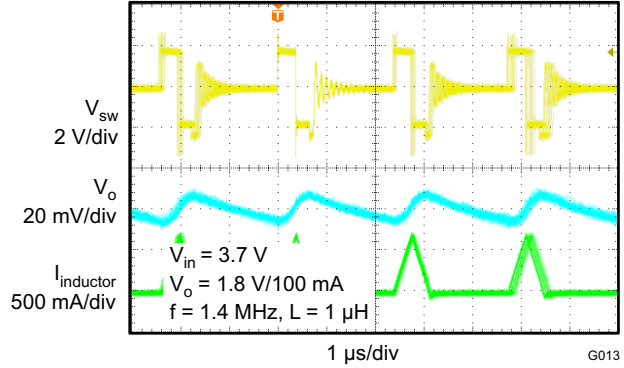

Figure 17. PFM Operation

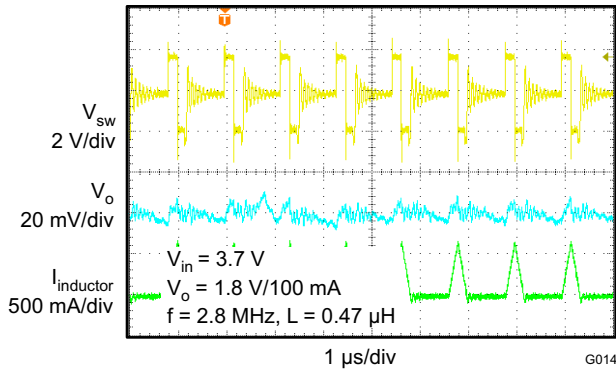

Figure 18. PFM Operation

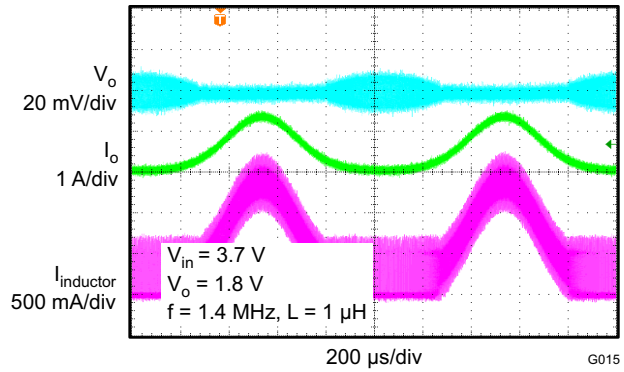

Figure 19. Load Sweep

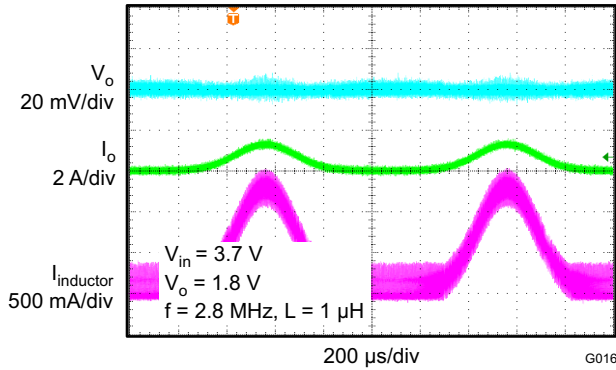

Figure 20. Load Sweep

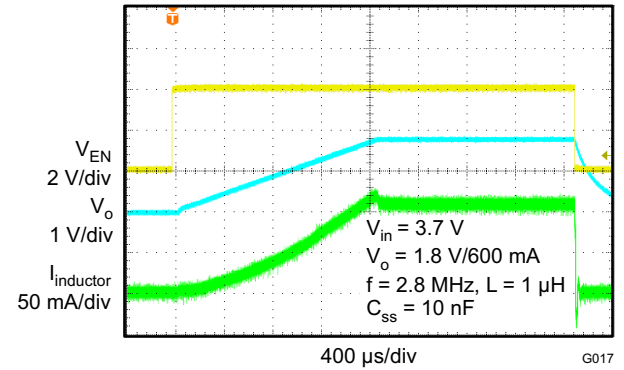

Figure 21. Start-Up

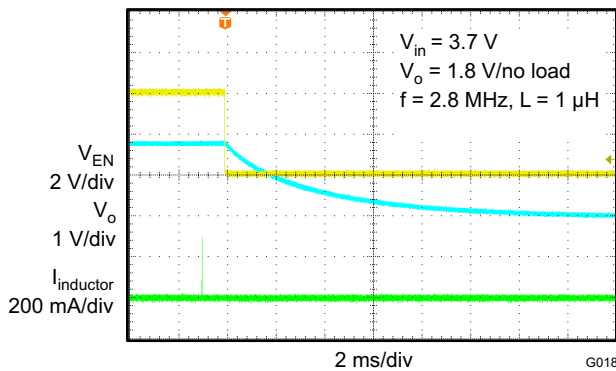

Figure 22. Shutdown

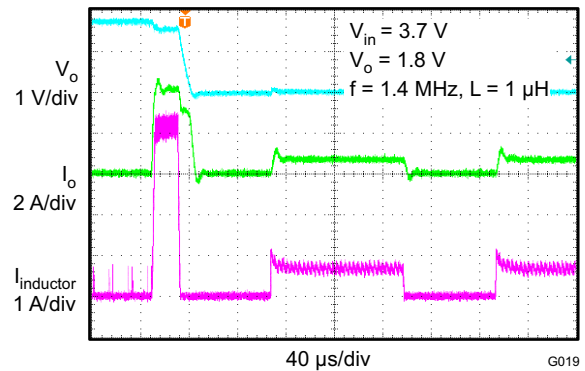
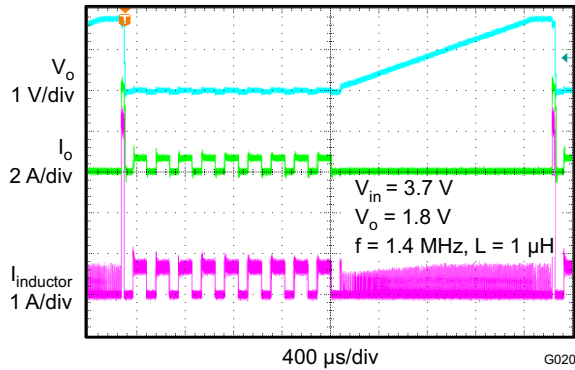
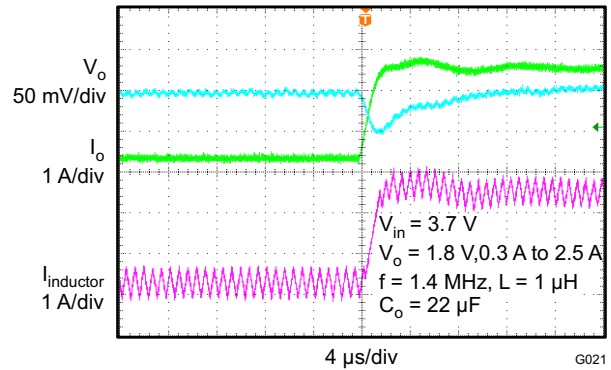
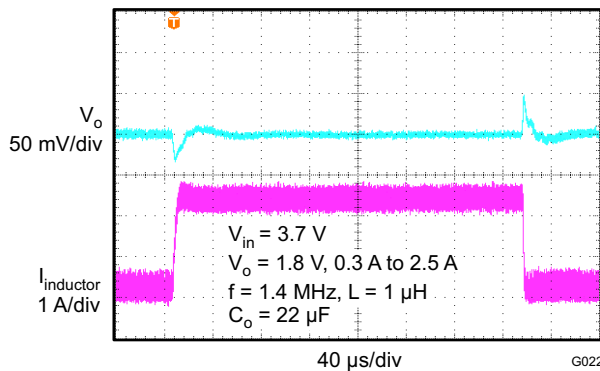
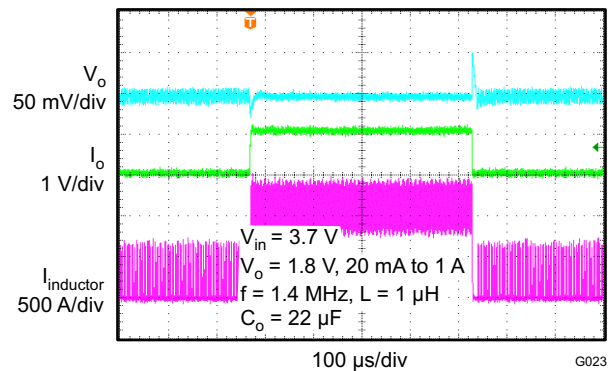

Figure 23. Hiccup Short Circuit Protection

**Figure 24. Hiccup Short Circuit Protection**

**Figure 25. Load Transient Response**

**Figure 26. Load Transient Response**

**Figure 27. Load Transient Response**

## DETAILED DESCRIPTION

### Operation

The TPS6209x synchronous switched mode converters are based on DCS™ Control (Direct Control with Seamless transition into Power Save Mode). This is an advanced regulation topology that combines the advantages of hysteretic and voltage mode control.

The DCS™ Control topology operates in PWM (Pulse Width Modulation) mode for medium to heavy load conditions and in Power Save Mode at light load currents. In PWM, the converter operates with its nominal switching frequency of 2.8 MHz/1.4 MHz having a controlled frequency variation over the input voltage range. As the load current decreases, the converter enters Power Save Mode, reducing the switching frequency and minimizing the IC quiescent current to achieve high efficiency over the entire load current range. DCS™ Control supports both operation modes (PWM and PFM) using a single building block having a seamless transition from PWM to Power Save Mode without effects on the output voltage. Fixed output voltage versions provide smallest solution size combined with lowest quiescent current. The TPS6209x family offers excellent DC voltage regulation and load transient regulation, combined with low output voltage ripple, minimizing interference with RF circuits.

### PWM Operation

At medium to heavy load currents, the device operates with pulse width modulation (PWM) at a nominal switching frequency of 2.8 MHz or 1.4 MHz depending on the setting of the FREQ pin. As the load current decreases, the converter enters the Power Save Mode operation reducing its switching frequency. The device enters Power Save Mode at the boundary to discontinuous conduction mode (DCM).

## Power Save Mode Operation

As the load current decreases, the converter enters Power Save Mode operation. During Power Save Mode the converter operates with reduced switching frequency in PFM mode and with a minimum quiescent current while maintaining high efficiency. The Power Save Mode is based on a fixed on-time architecture following Equation 1. When operating at 1.4 MHz the on-time is twice as long as the on-time for 2.8 MHz operation. This results in larger output voltage ripple, as shown in Figure 17 and Figure 18, and slightly higher output voltage at no load, as shown in Figure 8 and Figure 9. To have the same output voltage ripple at 1.4 MHz during PFM mode, either the output capacitor or the inductor value needs to be increased. As an example, operating at 2.8 MHz using 0.47 µH inductor gives the same output voltage ripple as operating with 1.4 MHz using 1 µH inductor.

$$\begin{aligned} t_{on,2.8\text{MHz}} &= \frac{V_{OUT}}{V_{IN}} \times 360\text{ns} \\ t_{on,1.4\text{MHz}} &= \frac{V_{OUT}}{V_{IN}} \times 360\text{ns} \times 2 \\ f &= \frac{2 \times I_{OUT}}{t_{on}^2 \left( 1 + \frac{V_{IN} - V_{OUT}}{V_{OUT}} \right) \times \frac{V_{IN} - V_{OUT}}{L}} \end{aligned} \quad (1)$$

In Power Save Mode the output voltage rises slightly above the nominal output voltage in PWM mode, as shown in Figure 8 and Figure 9. This effect can be reduced by increasing the output capacitance or the inductor value. This effect can also be reduced by programming the output voltage of the TPS62090 lower than the target value. As an example, if the target output voltage is 3.3 V, then the TPS62090 can be programmed to 3.3V - 0.8%. As a result the output voltage accuracy is now -2.2% to +2.2% instead of -1.4% to 3%. The output voltage accuracy in PFM operation is reflected in the electrical specification table and given for a 22 µF output capacitance.

## Low Dropout Operation (100% Duty Cycle)

The device offers low input to output voltage difference by entering 100% duty cycle mode. In this mode the high side MOSFET switch is constantly turned on. This is particularly useful in battery powered applications to achieve longest operation time by taking full advantage of the whole battery voltage range. The minimum input voltage where the output voltage falls below its nominal regulation value is given by:

$$V_{IN(\text{min})} = V_{OUT(\text{max})} + I_{OUT} \times (R_{DS(\text{on})} + R_L) \quad (2)$$

Where

$R_{DS(\text{on})}$  = High side FET on-resistance

$R_L$  = DC resistance of the inductor

$V_{OUT(\text{max})}$  = nominal output voltage plus maximum output voltage tolerance

## Softstart (SS)

To minimize inrush current during start up, the device has an adjustable softstart depending on the capacitor value connected to the SS pin. The device charges the softstart capacitor with a constant current of typically 7.5 µA. The feedback voltage follows this voltage with a fraction of 1.56 until the internal reference voltage of 0.8 V is reached. The softstart operation is completed once the voltage at the softstart capacitor has reached typically 1.25 V. The soft-start time can be calculated using Equation 3. The larger the softstart capacitor the longer the softstart time. The relation between softstart voltage and feedback voltage can be estimated using Equation 4.

$$t_{SS} = C_{SS} \times \frac{1.25\text{V}}{7.5\mu\text{A}} \quad (3)$$

$$V_{FB} = \frac{V_{SS}}{1.56} \quad (4)$$

This is also the case for the fixed output voltage option having the internal regulation voltage. Leaving the softstart pin floating sets the minimum start-up time.

## Start-up Tracking (SS)

The softstart pin can also be used to implement output voltage tracking with other supply rails. The internal reference voltage follows the voltage at the softstart pin with a fraction of 1.56 until the internal reference voltage of 0.8 V is reached. The softstart pin can be used to implement output voltage tracking as shown in [Figure 28](#).

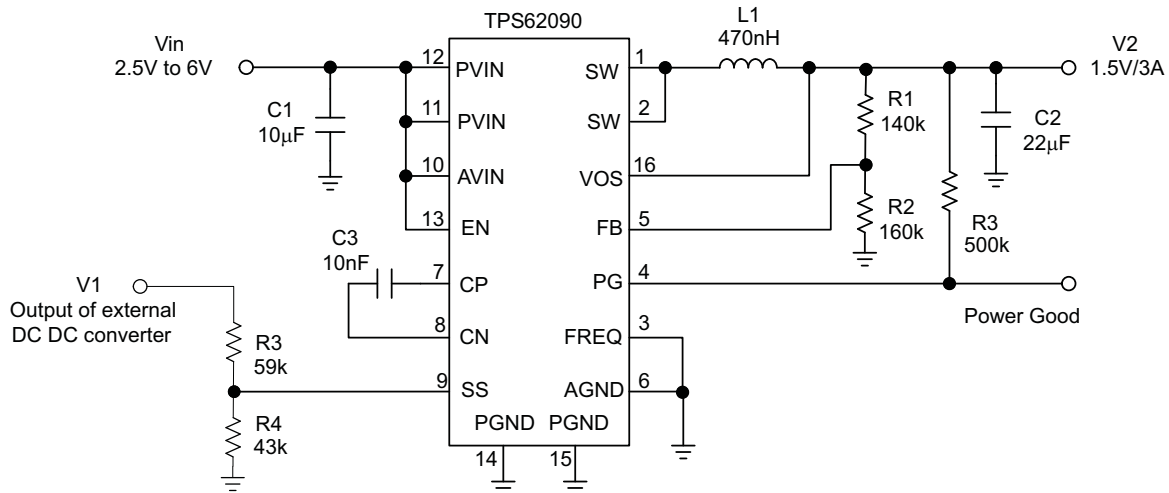

**Figure 28. Output Voltage Tracking**

In [Figure 28](#), the output V2 will track the voltage applied to V1. The voltage will track simultaneously when following conditions are met:

$$\frac{R3}{R4} = \frac{R1}{R2} \times 1.56 \quad (5)$$

As the fraction of R3/R4 becomes larger the voltage V1 will ramp up faster than V2 and if it gets smaller than the ramp will be slower than V2. R4 needs to be determined first using [Equation 6](#).

$$R4 = \frac{1.25V}{300\mu A} \quad (6)$$

In the calculation of R4, 300 µA current is used to achieve sufficient accuracy by taking into account the typical 7.5 µA soft-start current. After determining R4, R3 can be calculated using [Equation 5](#).

## Short Circuit Protection (Hiccup-Mode)

The device is protected against hard short circuits to GND and over-current events. This is implemented by a two level short circuit protection. During start-up and when the output is shorted to GND the switch current limit is reduced to 1/3 of its typical current limit of 4.6 A. Once the output voltage exceeds typically 0.6 V the current limit is released to its nominal value. The full current limit is implemented as a hiccup current limit. Once the internal current limits is triggered 32 times the device stops switching and starts a new start-up sequence after a typical delay time of 66 µS passed by. The device will go through these cycles until the high current condition is released.

## Output Discharge Function

To make sure the device starts up under defined conditions, the output gets discharged via the VOS pin with a typical discharge resistor of 200 Ω whenever the device shuts down. This happens when the device is disabled or if thermal shutdown, undervoltage lockout or short circuit hiccup-mode is triggered.

## Power Good Output (PG)

The power good output is low when the output voltage is below its nominal value. The power good will become high impedance once the output is within 5% of regulation. The PG pin is an open drain output and is specified to typically sink up to 1 mA. This output requires a pull-up resistor to be monitored properly. The pull-up resistor cannot be connected to any voltage higher than the input voltage of the device.

## Frequency Set Pin (FREQ)

The FREQ pin is a digital logic input which sets the nominal switching frequency. Pulling this pin to GND sets the nominal switching frequency to 2.8 MHz and pulling this pin high sets the nominal switching frequency to 1.4 MHz. Since this pin changes the switching frequency it also changes the on-time during PFM mode. At 1.4 MHz the on-time is twice the on-time as operating at 2.8 MHz. This pin has an active pull-down resistor of typically 400 kΩ. For applications where efficiency is of highest importance, a lower switching frequency should be selected. A higher switching frequency allows the use of smaller external components, faster load transient response and lower output voltage ripple when using same L-C values.

## Undervoltage Lockout (UVLO)

To avoid mis-operation of the device at low input voltages, an undervoltage lockout is included. UVLO shuts down the device at input voltages lower than typically 2.2 V with a 200 mV hysteresis.

## Thermal Shutdown

The device goes into thermal shutdown once the junction temperature exceeds typically 150°C with a 20°C hysteresis.

# APPLICATION INFORMATION

## DESIGN PROCEDURE

The first step is the selection of the output filter components. To simplify this process, [Table 2](#) and [Table 3](#) outline possible inductor and capacitor value combinations.

**Table 2. Output Filter Selection (2.8 MHz Operation, FREQ = GND)**

INDUCTOR VALUE [μH] <sup>(1)</sup>	OUTPUT CAPACITOR VALUE [μF] <sup>(2)</sup>				
	10	22	47	100	150
0.47		√ <sup>(3)</sup>	√	√	√
1.0	√	√	√	√	√
2.2					
3.3					

- (1) Inductor tolerance and current de-rating is anticipated. The effective inductance can vary by +20% and -30%.
- (2) Capacitance tolerance and bias voltage de-rating is anticipated. The effective capacitance can vary by +20% and -50%.
- (3) Typical application configuration. Other check mark indicates alternative filter combinations

**Table 3. Output Filter Selection (1.4 MHz Operation, FREQ = V<sub>IN</sub>)**

INDUCTOR VALUE [μH] <sup>(1)</sup>	OUTPUT CAPACITOR VALUE [μF] <sup>(2)</sup>				
	10	22	47	100	150
0.47		√	√	√	√
1.0	√	√ <sup>(3)</sup>	√	√	√
2.2	√	√	√	√	√
3.3					

- (1) Inductor tolerance and current de-rating is anticipated. The effective inductance can vary by +20% and -30%.
- (2) Capacitance tolerance and bias voltage de-rating is anticipated. The effective capacitance can vary by +20% and -50%.
- (3) Typical application configuration. Other check mark indicates alternative filter combinations

## Inductor Selection

The inductor selection is affected by several parameter like inductor ripple current, output voltage ripple, transition point into Power Save Mode, and efficiency. See [Table 4](#) for typical inductors.

**Table 4. Inductor Selection**

INDUCTOR VALUE	COMPONENT SUPPLIER	SIZE (LxWxH mm)	I <sub>sat</sub> /DCR
0.6 μH	Coilcraft XAL4012-601	4 x 4 x 2.1	7.1A/9.5 mΩ
1 μH	Coilcraft XAL4020-102	4 x 4 x 2.1	5.9A/13.2 mΩ
1 μH	Coilcraft XFL4020-102	4 x 4 x 2.1	5.1 A/10.8 mΩ
0.47 μH	TOKO DFE252012 R47	2.5 x 2 x 1.2	3.7A/39 mΩ
1 μH	TOKO DFE252012 1R0	2.5 x 2 x 1.2	3.0A/59 mΩ
0.68 μH	TOKO DFE322512 R68	3.2 x 2.5 x 1.2	3.5A/37 mΩ
1 μH	TOKO DFE322512 1R0	3.2 x 2.5 x 1.2	3.1A/45 mΩ

In addition, the inductor has to be rated for the appropriate saturation current and DC resistance (DCR). The inductor needs to be rated for a saturation current as high as the typical switch current limit, of 4.6 A or according to [Equation 7](#) and [Equation 8](#). [Equation 7](#) and [Equation 8](#) calculate the maximum inductor current under static load conditions. The formula takes the converter efficiency into account. The converter efficiency can be taken from the data sheet graph's or 80% can be used as a conservative approach. The calculation must be done for the maximum input voltage where the peak switch current is highest.

$$I_L = I_{OUT} + \frac{\Delta I_L}{2} \quad (7)$$

$$I_L = I_{OUT} + \frac{\frac{V_{OUT}}{\eta} \times \left(1 - \frac{V_{OUT}}{V_{IN} \times \eta}\right)}{2 \times f \times L} \quad (8)$$

where

$f$  = Converter switching frequency (typical 2.8 MHz or 1.4 MHz)

$L$  = Selected inductor value

$\eta$  = Estimated converter efficiency (use the number from the efficiency curves or 0.80 as an conservative assumption)

**Note:** The calculation must be done for the maximum input voltage of the application

Calculating the maximum inductor current using the actual operating conditions gives the minimum saturation current. A margin of 20% needs to be added to cover for load transients during operation.

## Input and Output Capacitor Selection

For best output and input voltage filtering, low ESR ceramic capacitors are recommended. The input capacitor minimizes input voltage ripple, suppresses input voltage spikes and provides a stable system rail for the device. A 22 μF or larger input capacitor is recommended for 1.4 MHz operation frequency. For 2.8 MHz operation frequency a 10 μF input capacitor or larger is recommended. The output capacitor value can range from 10 μF up to 150 μF and beyond. The recommended typical output capacitor value is 22 μF and can vary over a wide range as outline in the output filter selection table.

**Table 5. Input Capacitor Selection**

INPUT CAPACITOR	COMMENT
10 μF	FREQ=low, f=2.8 MHz
22 μF	FREQ=high, f=1.4 MHz

## Setting the Output Voltage

The output voltage is set by an external resistor divider according to the following equations:

$$V_{OUT} = V_{FB} \times \left( 1 + \frac{R1}{R2} \right) = 0.8 \text{ V} \times \left( 1 + \frac{R1}{R2} \right) \quad (9)$$

$$R2 = \frac{V_{FB}}{I_{FB}} = \frac{0.8 \text{ V}}{5 \mu\text{A}} \approx 160 \text{ k}\Omega \quad (10)$$

$$R1 = R2 \times \left( \frac{V_{OUT}}{V_{FB}} - 1 \right) = R2 \times \left( \frac{V_{OUT}}{0.8\text{V}} - 1 \right) \quad (11)$$

When sizing R2, in order to achieve low quiescent current and acceptable noise sensitivity, use a minimum of 5  $\mu\text{A}$  for the feedback current  $I_{FB}$ . Larger currents through R2 improve noise sensitivity and output voltage accuracy. Lowest quiescent current and best output voltage accuracy can be achieved with the fixed output voltage versions. For the fixed output voltage versions, the FB pin can be left floating or connected to GND to improve the thermal package performance.

## Layout Guideline

It is recommended to place all components as close as possible to the IC. The VOS connection is noise sensitive and needs to be routed as short and directly to the output terminal of the inductor. The exposed thermal pad of the package, analog ground (pin 6) and power ground (pin 14, 15) should have a single joint connection at the exposed thermal pad of the package. This minimizes switch node jitter. The charge pump capacitor connected to CP and CN should be placed close to the IC to minimize coupling of switching waveforms into other traces and circuits. Refer to the evaluation module User Guide (SLVU670) for an example of component placement, routing and thermal design.

## TYPICAL APPLICATIONS

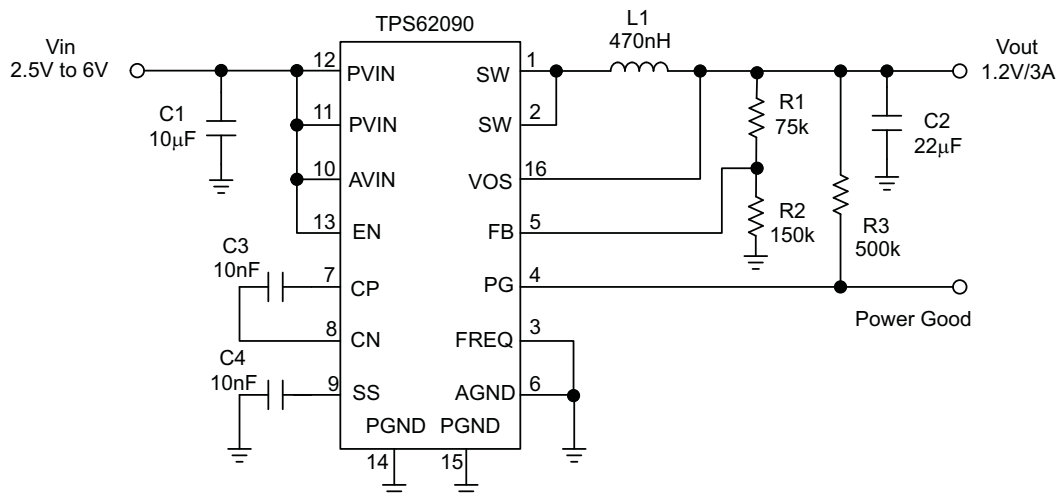

Figure 29. 1.2 V Adjustable Version Operating at 2.8 MHz



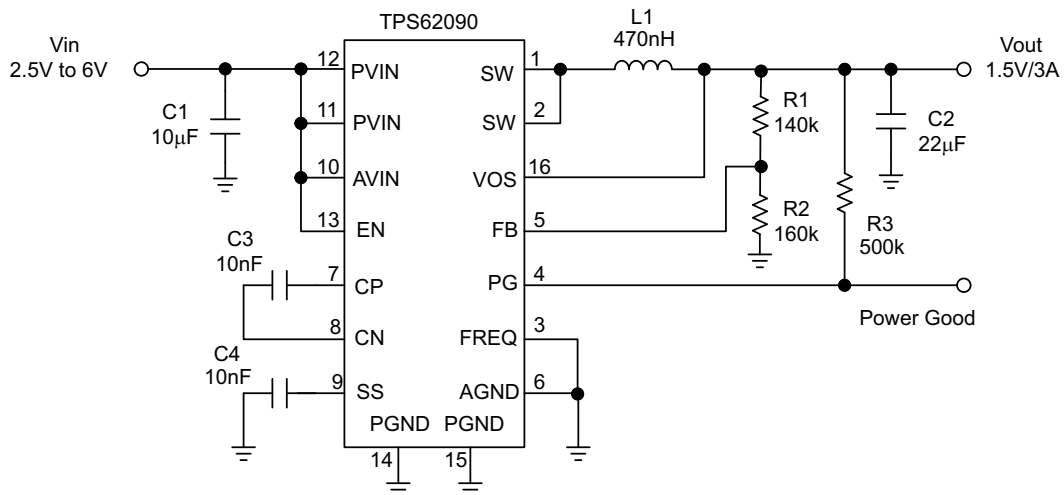

Figure 30. 1.5 V Adjustable Version Operating at 2.8 MHz

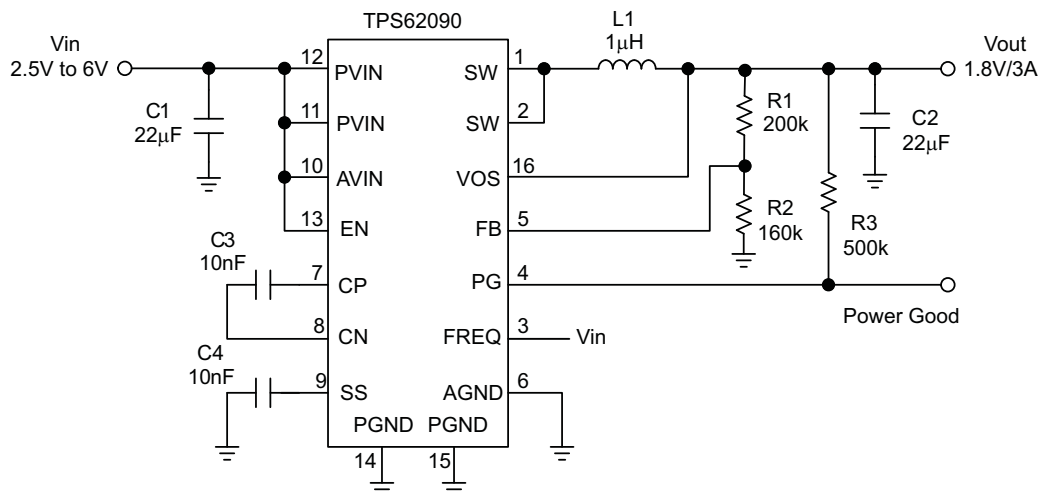

Figure 31. 1.8 V Adjustable Version Operating at 1.4 MHz

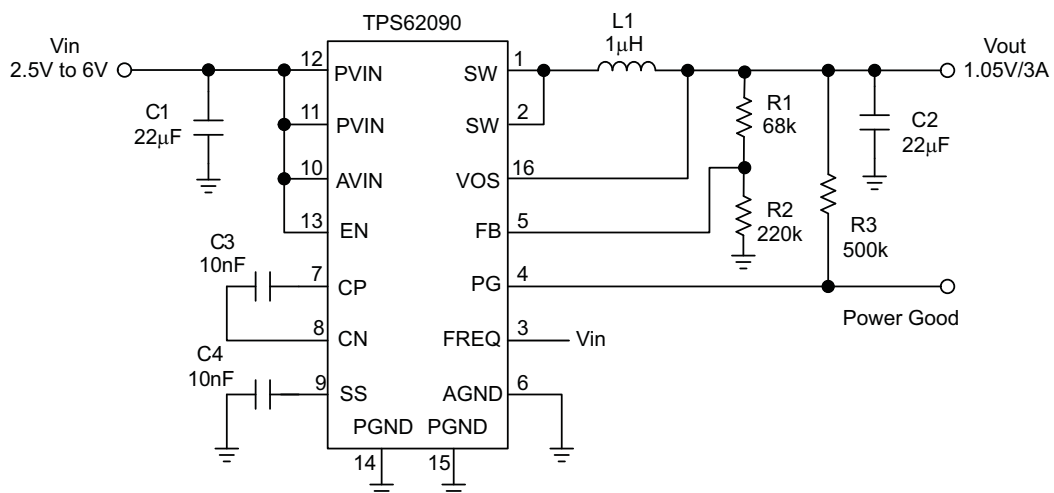

Figure 32. 1.05 V Adjustable Version Operating at 1.4 MHz

## REVISION HISTORY

Changes from Original (March 2012) to Revision A	Page
• Changed the FUNCTIONAL BLOCK DIAGRAM .....	5
• Changed R1, R2 and R4 values in <a href="#">Figure 28</a> .....	13
• Changed R1 and R2 values in <a href="#">Figure 29</a> .....	16

**PACKAGING INFORMATION**

Orderable Device	Status (1)	Package Type	Package Drawing	Pins	Package Qty	Eco Plan (2)	Lead finish/ Ball material (6)	MSL Peak Temp (3)	Op Temp (°C)	Device Marking (4/5)	Samples
TPS62090RGTR	ACTIVE	VQFN	RGT	16	3000	RoHS & Green	NIPDAU	Level-2-260C-1 YEAR	-40 to 85	SBW	<a href="#">Samples</a>
TPS62090RGTT	ACTIVE	VQFN	RGT	16	250	RoHS & Green	NIPDAU	Level-2-260C-1 YEAR	-40 to 85	SBW	<a href="#">Samples</a>
TPS62091RGTR	ACTIVE	VQFN	RGT	16	3000	RoHS & Green	NIPDAU	Level-2-260C-1 YEAR	-40 to 85	SBX	<a href="#">Samples</a>
TPS62091RGTT	ACTIVE	VQFN	RGT	16	250	RoHS & Green	NIPDAU	Level-2-260C-1 YEAR	-40 to 85	SBX	<a href="#">Samples</a>
TPS62092RGTR	ACTIVE	VQFN	RGT	16	3000	RoHS & Green	NIPDAU	Level-2-260C-1 YEAR	-40 to 85	SBY	<a href="#">Samples</a>
TPS62092RGTT	ACTIVE	VQFN	RGT	16	250	RoHS & Green	NIPDAU	Level-2-260C-1 YEAR	-40 to 85	SBY	<a href="#">Samples</a>
TPS62093RGTR	ACTIVE	VQFN	RGT	16	3000	RoHS & Green	NIPDAU	Level-2-260C-1 YEAR	-40 to 85	SBZ	<a href="#">Samples</a>
TPS62093RGTT	ACTIVE	VQFN	RGT	16	250	RoHS & Green	NIPDAU	Level-2-260C-1 YEAR	-40 to 85	SBZ	<a href="#">Samples</a>

(1) The marketing status values are defined as follows:

**ACTIVE:** Product device recommended for new designs.

**LIFEBUY:** TI has announced that the device will be discontinued, and a lifetime-buy period is in effect.

**NRND:** Not recommended for new designs. Device is in production to support existing customers, but TI does not recommend using this part in a new design.

**PREVIEW:** Device has been announced but is not in production. Samples may or may not be available.

**OBSOLETE:** TI has discontinued the production of the device.

(2) **RoHS:** TI defines "RoHS" to mean semiconductor products that are compliant with the current EU RoHS requirements for all 10 RoHS substances, including the requirement that RoHS substance do not exceed 0.1% by weight in homogeneous materials. Where designed to be soldered at high temperatures, "RoHS" products are suitable for use in specified lead-free processes. TI may reference these types of products as "Pb-Free".

**RoHS Exempt:** TI defines "RoHS Exempt" to mean products that contain lead but are compliant with EU RoHS pursuant to a specific EU RoHS exemption.

**Green:** TI defines "Green" to mean the content of Chlorine (Cl) and Bromine (Br) based flame retardants meet JS709B low halogen requirements of <=1000ppm threshold. Antimony trioxide based flame retardants must also meet the <=1000ppm threshold requirement.

(3) MSL, Peak Temp. - The Moisture Sensitivity Level rating according to the JEDEC industry standard classifications, and peak solder temperature.

(4) There may be additional marking, which relates to the logo, the lot trace code information, or the environmental category on the device.

(5) Multiple Device Markings will be inside parentheses. Only one Device Marking contained in parentheses and separated by a "~" will appear on a device. If a line is indented then it is a continuation of the previous line and the two combined represent the entire Device Marking for that device.

<sup>(6)</sup> Lead finish/Ball material - Orderable Devices may have multiple material finish options. Finish options are separated by a vertical ruled line. Lead finish/Ball material values may wrap to two lines if the finish value exceeds the maximum column width.

**Important Information and Disclaimer:** The information provided on this page represents TI's knowledge and belief as of the date that it is provided. TI bases its knowledge and belief on information provided by third parties, and makes no representation or warranty as to the accuracy of such information. Efforts are underway to better integrate information from third parties. TI has taken and continues to take reasonable steps to provide representative and accurate information but may not have conducted destructive testing or chemical analysis on incoming materials and chemicals. TI and TI suppliers consider certain information to be proprietary, and thus CAS numbers and other limited information may not be available for release.

In no event shall TI's liability arising out of such information exceed the total purchase price of the TI part(s) at issue in this document sold by TI to Customer on an annual basis.

**TAPE AND REEL INFORMATION**

**QUADRANT ASSIGNMENTS FOR PIN 1 ORIENTATION IN TAPE**

\*All dimensions are nominal

Device	Package Type	Package Drawing	Pins	SPQ	Reel Diameter (mm)	Reel Width W1 (mm)	A0 (mm)	B0 (mm)	K0 (mm)	P1 (mm)	W (mm)	Pin1 Quadrant
TPS62090RGTR	VQFN	RGT	16	3000	330.0	12.4	3.3	3.3	1.1	8.0	12.0	Q2
TPS62090RGTT	VQFN	RGT	16	250	180.0	12.4	3.3	3.3	1.1	8.0	12.0	Q2
TPS62091RGTR	VQFN	RGT	16	3000	330.0	12.4	3.3	3.3	1.1	8.0	12.0	Q2
TPS62091RGTR	VQFN	RGT	16	3000	330.0	12.4	3.3	3.3	1.1	8.0	12.0	Q2
TPS62091RGTT	VQFN	RGT	16	250	180.0	12.5	3.3	3.3	1.1	8.0	12.0	Q2
TPS62091RGTT	VQFN	RGT	16	250	180.0	12.4	3.3	3.3	1.1	8.0	12.0	Q2
TPS62092RGTR	VQFN	RGT	16	3000	330.0	12.4	3.3	3.3	1.1	8.0	12.0	Q2
TPS62092RGTR	VQFN	RGT	16	3000	330.0	12.4	3.3	3.3	1.1	8.0	12.0	Q2
TPS62092RGTT	VQFN	RGT	16	250	180.0	12.5	3.3	3.3	1.1	8.0	12.0	Q2
TPS62093RGTR	VQFN	RGT	16	3000	330.0	12.4	3.3	3.3	1.1	8.0	12.0	Q2
TPS62093RGTT	VQFN	RGT	16	250	180.0	12.5	3.3	3.3	1.1	8.0	12.0	Q2

**TAPE AND REEL BOX DIMENSIONS**

\*All dimensions are nominal

Device	Package Type	Package Drawing	Pins	SPQ	Length (mm)	Width (mm)	Height (mm)
TPS62090RGTR	VQFN	RGT	16	3000	346.0	346.0	33.0
TPS62090RGTT	VQFN	RGT	16	250	210.0	185.0	35.0
TPS62091RGTR	VQFN	RGT	16	3000	338.0	355.0	50.0
TPS62091RGTR	VQFN	RGT	16	3000	346.0	346.0	33.0
TPS62091RGTT	VQFN	RGT	16	250	338.0	355.0	50.0
TPS62091RGTT	VQFN	RGT	16	250	210.0	185.0	35.0
TPS62092RGTR	VQFN	RGT	16	3000	346.0	346.0	33.0
TPS62092RGTR	VQFN	RGT	16	3000	338.0	355.0	50.0
TPS62092RGTT	VQFN	RGT	16	250	338.0	355.0	50.0
TPS62093RGTR	VQFN	RGT	16	3000	338.0	355.0	50.0
TPS62093RGTT	VQFN	RGT	16	250	338.0	355.0	50.0

**RGT 16**

**GENERIC PACKAGE VIEW**

**VQFN - 1 mm max height**

PLASTIC QUAD FLATPACK - NO LEAD

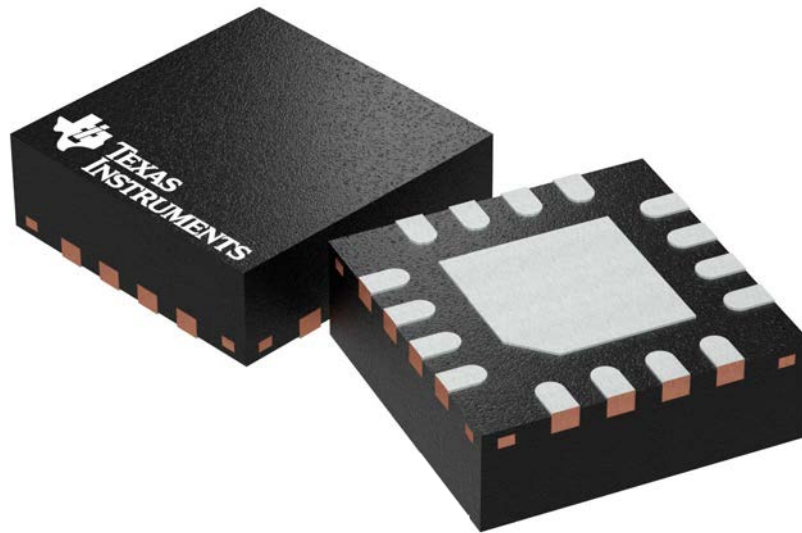

Images above are just a representation of the package family, actual package may vary.  
Refer to the product data sheet for package details.

4203495/1



SIDE WALL METAL THICKNESS DIM A	
OPTION 1	OPTION 2
0.1	0.2



4222419/D 04/2022

NOTES:

1. All linear dimensions are in millimeters. Any dimensions in parenthesis are for reference only. Dimensioning and tolerancing per ASME Y14.5M.
2. This drawing is subject to change without notice.
3. The package thermal pad must be soldered to the printed circuit board for thermal and mechanical performance.





# EXAMPLE STENCIL DESIGN

RGT0016C

VQFN - 1 mm max height

PLASTIC QUAD FLATPACK - NO LEAD



**SOLDER PASTE EXAMPLE**  
BASED ON 0.125 mm THICK STENCIL

EXPOSED PAD 17:  
85% PRINTED SOLDER COVERAGE BY AREA UNDER PACKAGE  
SCALE:25X

4222419/D 04/2022

NOTES: (continued)

6. Laser cutting apertures with trapezoidal walls and rounded corners may offer better paste release. IPC-7525 may have alternate design recommendations.

## 重要声明和免责声明

TI“按原样”提供技术和可靠性数据（包括数据表）、设计资源（包括参考设计）、应用或其他设计建议、网络工具、安全信息和其他资源，不保证没有瑕疵且不做任何明示或暗示的担保，包括但不限于对适销性、某特定用途方面的适用性或不侵犯任何第三方知识产权的暗示担保。

这些资源可供使用 TI 产品进行设计的熟练开发人员使用。您将自行承担以下全部责任：(1) 针对您的应用选择合适的 TI 产品，(2) 设计、验证并测试您的应用，(3) 确保您的应用满足相应标准以及任何其他功能安全、信息安全、监管或其他要求。

这些资源如有变更，恕不另行通知。TI 授权您仅可将这些资源用于研发本资源所述的 TI 产品的应用。严禁对这些资源进行其他复制或展示。您无权使用任何其他 TI 知识产权或任何第三方知识产权。您应全额赔偿因在这些资源的使用中对 TI 及其代表造成的任何索赔、损害、成本、损失和债务，TI 对此概不负责。

TI 提供的产品受 [TI 的销售条款](#) 或 [ti.com](#) 上其他适用条款/TI 产品随附的其他适用条款的约束。TI 提供这些资源并不会扩展或以其他方式更改 TI 针对 TI 产品发布的适用的担保或担保免责声明。

TI 反对并拒绝您可能提出的任何其他或不同的条款。

邮寄地址：Texas Instruments, Post Office Box 655303, Dallas, Texas 75265

Copyright © 2024，德州仪器 (TI) 公司