

TS3A5018 10Ω 四通道 SPDT 模拟开关

1 特性

- 低通态电阻 (10Ω)
- 低电荷注入
- 出色的通态电阻匹配
- 低总谐波失真 (THD)
- 1.8V 至 3.6V 单电源运行
- 闩锁性能超出 JESD 78 II 类规范要求的 100mA
- 静电放电 (ESD) 性能测试符合 JESD 22 标准
 - 2000V 人体放电模型 (A114-B, II 类)
 - 1000V 充电器件模型 (C101)

2 应用

- 采样和保持电路
- 电池供电类设备
- 音频和视频信号路由
- 通信电路

3 说明

TS3A5018 器件是一款四通道单极双投 (SPDT) 模拟开关, 其设计工作电压为 1.8V 至 3.6V。此器件可以处理数据和模拟信号, 并且高达 V_+ 的信号在任一方向上传输。

器件信息⁽¹⁾

器件型号	封装	封装尺寸 (标称值)
TS3A5018	SOIC (16)	9.90mm × 6.00mm
	SSOP (16)	6.00mm × 4.90mm
	TSSOP (16)	5.00mm × 4.40mm
	TVSOP (16)	4.40mm × 3.60mm
	UQFN (16)	2.50mm × 1.80mm
	VQFN (16)	4.00mm × 3.50mm

(1) 如需了解所有可用封装, 请参阅数据表末尾的可订购产品附录。

方框图

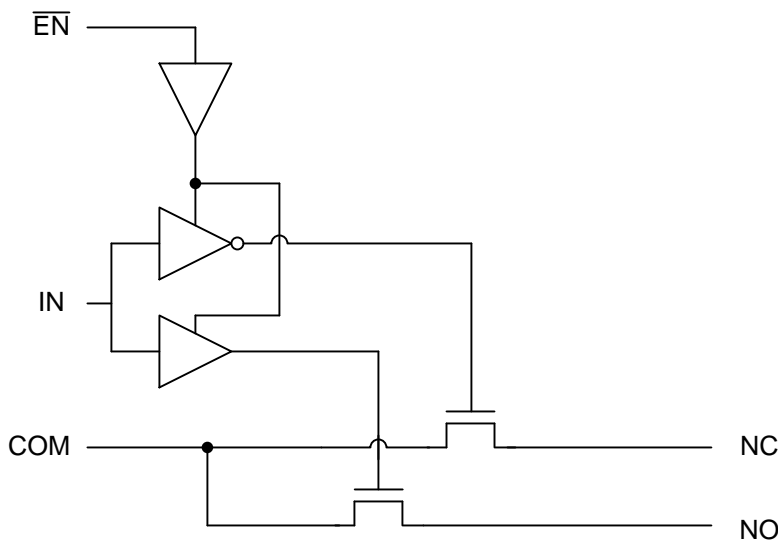

目录

<p>1 特性 1</p> <p>2 应用 1</p> <p>3 说明 1</p> <p>4 修订历史记录 2</p> <p>5 Pin Configuration and Functions 3</p> <p>6 Specifications 4</p> <p> 6.1 Absolute Maximum Ratings 4</p> <p> 6.2 ESD Ratings 4</p> <p> 6.3 Recommended Operating Conditions 4</p> <p> 6.4 Thermal Information 4</p> <p> 6.5 Electrical Characteristics for 3.3-V Supply 5</p> <p> 6.6 Electrical Characteristics for 2.5-V Supply 6</p> <p> 6.7 Electrical Characteristics for 2.1-V Supply 7</p> <p> 6.8 Electrical Characteristics for 1.8-V Supply 7</p> <p> 6.9 Switching Characteristics for 3.3-V Supply 8</p> <p> 6.10 Switching Characteristics for 2.5-V Supply 8</p> <p> 6.11 Switching Characteristics for 1.8-V Supply 9</p> <p> 6.12 Typical Characteristics 10</p> <p>7 Parameter Measurement Information 13</p> <p>8 Detailed Description 17</p>	<p>8.1 Overview 17</p> <p>8.2 Functional Block Diagram (Each Switch) 17</p> <p>8.3 Feature Description 17</p> <p>8.4 Device Functional Modes 17</p> <p>9 Application and Implementation 18</p> <p> 9.1 Application Information 18</p> <p> 9.2 Typical Application 18</p> <p>10 Power Supply Recommendations 19</p> <p>11 Layout 19</p> <p> 11.1 Layout Guidelines 19</p> <p> 11.2 Layout Example 19</p> <p>12 器件和文档支持 20</p> <p> 12.1 器件支持 20</p> <p> 12.2 文档支持 20</p> <p> 12.3 接收文档更新通知 21</p> <p> 12.4 社区资源 21</p> <p> 12.5 商标 21</p> <p> 12.6 静电放电警告 21</p> <p> 12.7 术语表 21</p> <p>13 机械、封装和可订购信息 21</p>
--	---

4 修订历史记录

注：之前版本的页码可能与当前版本有所不同。

Changes from Revision G (March 2015) to Revision H	Page
• Changed the pinout images.....	3
• Changed the r_{on} MAX value at 25°C From: 8 Ω To: 17 Ω in the <i>Electrical Characteristics for 1.8-V Supply</i> table.....	7
• Changed the r_{on} MAX value at Full From: 14.55 Ω To: 32 Ω in the <i>Electrical Characteristics for 1.8-V Supply</i> table.....	7

Changes from Revision F (June 2013) to Revision G	Page
• 添加了应用、器件信息表、引脚功能表、ESD 额定值表、热性能信息表、典型特性、特性说明部分、器件功能模式、应用和实施部分、电源建议部分、布局部分、器件和文档支持部分以及机械、封装和可订购信息部分。.....	1
• 已删除 订购信息表。.....	1

5 Pin Configuration and Functions

D, DBQ, DGV and PW Package
16-Pin SOIC, SSOP, TVSOP and TSSOP
(Top View)

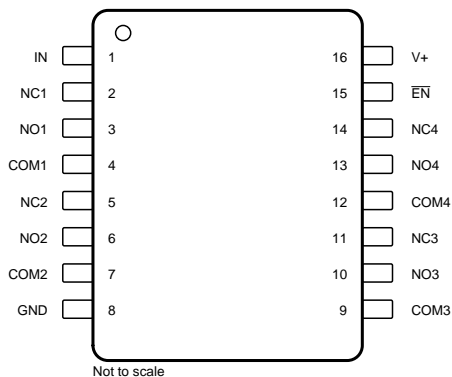

Logic Circuit

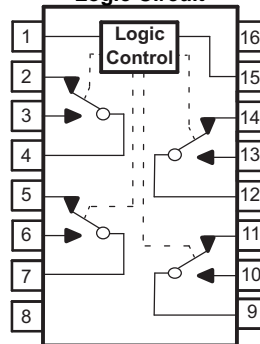

RGY Package
16-Pin VQFN
(Top View)

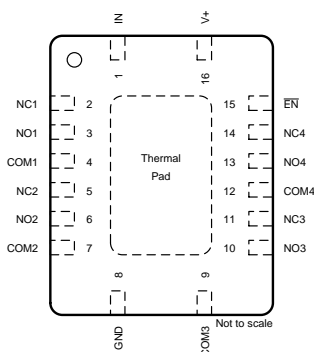

RSV Package
16-Pin UQFN
(Top View)

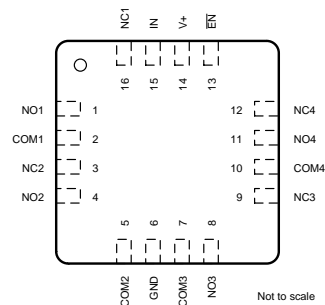

Pin Functions

NAME	PIN		TYPE	DESCRIPTION
	SOIC, SSOP, TVSOP, VQFN NO.	UQFN NO.		
COM1	4	2	I/O	Common path for switch
COM2	7	5	I/O	Common path for switch
COM3	9	7	I/O	Common path for switch
COM4	12	10	I/O	Common path for switch
EN	15	13	I	Active-low switch enable input
GND	8	6	—	Ground
IN	1	15	I	Switch path selector input
NC1	2	16	I/O	Normally closed path for switch
NC2	5	3	I/O	Normally closed path for switch
NC3	11	9	I/O	Normally closed path for switch
NC4	14	12	I/O	Normally closed path for switch
NO1	3	1	I/O	Normally open path for switch
NO2	6	4	I/O	Normally open path for switch
NO3	10	8	I/O	Normally open path for switch
NO4	13	11	I/O	Normally open path for switch
V+	16	14	—	Supply voltage

6 Specifications

6.1 Absolute Maximum Ratings

 over operating free-air temperature range (unless otherwise noted)⁽¹⁾⁽²⁾

		MIN	MAX	UNIT		
V ₊	Supply voltage ⁽³⁾	-0.5	4.6	V		
V _{NC}	Analog voltage ⁽³⁾⁽⁴⁾	-0.5	4.6	V		
V _{NO}						
V _{COM}						
I _K	Analog port diode current	V _{NC} , V _{NO} , V _{COM} < 0		-50	mA	
I _{NC}	ON-state switch current	V _{NC} , V _{NO} , V _{COM} = 0 to 7 V		-64	64	mA
I _{NO}						
I _{COM}						
V _I	Digital input voltage ⁽³⁾⁽⁴⁾	-0.5	4.6	V		
I _{IK}	Digital input clamp current	V _I < 0		-50	mA	
I ₊	Continuous current through V ₊	-100	100	mA		
I _{GND}	Continuous current through GND	-100	100	mA		
T _{stg}	Storage temperature	-65	150	°C		

- (1) Stresses beyond those listed under *Absolute Maximum Ratings* may cause permanent damage to the device. These are stress ratings only, and functional operation of the device at these or any other conditions beyond those indicated under *Recommended Operating Conditions* is not implied. Exposure to absolute-maximum-rated conditions for extended periods may affect device reliability.
- (2) The algebraic convention, whereby the most negative value is a minimum and the most positive value is a maximum
- (3) All voltages are with respect to ground, unless otherwise specified.
- (4) The input and output voltage ratings may be exceeded if the input and output clamp-current ratings are observed.

6.2 ESD Ratings

		VALUE	UNIT
V _(ESD)	Electrostatic discharge	Human-body model (HBM), per ANSI/ESDA/JEDEC JS-001 ⁽¹⁾	±2000
		Charged-device model (CDM), per JEDEC specification JESD22-C101 ⁽²⁾	±1000

- (1) JEDEC document JEP155 states that 500-V HBM allows safe manufacturing with a standard ESD control process.
- (2) JEDEC document JEP157 states that 250-V CDM allows safe manufacturing with a standard ESD control process.

6.3 Recommended Operating Conditions

over operating free-air temperature range (unless otherwise noted)

		MIN	MAX	UNIT
V _{I/O}	Switch input and output voltage	0	V ₊	V
V ₊	Supply voltage	1.65	3.6	V
V _I	Control input voltage	0	3.6	V
T _A	Operating temperature	-40	85	°C

6.4 Thermal Information

THERMAL METRIC ⁽¹⁾	TS3A5018						UNIT	
	D (SOIC)	DBQ (SSOP)	DGV (TVSOP)	PW (TSSOP)	RGY (VQFN)	RSV (UQFN)		
	16 PINS	16 PINS	16 PINS	16 PINS	16 PINS	16 PINS		
R _{θJA}	Junction-to-ambient thermal resistance	73	90	120	108	51	184	°C/W

- (1) For more information about traditional and new thermal metrics, see the [Semiconductor and IC Package Thermal Metrics](#) application report.

6.5 Electrical Characteristics for 3.3-V Supply

 $V_+ = 3\text{ V to }3.6\text{ V}$, $T_A = -40^\circ\text{C to }85^\circ\text{C}$ (unless otherwise noted)⁽¹⁾

PARAMETER		TEST CONDITIONS		T_A	V_+	MIN	TYP	MAX	UNIT
Analog Switch									
V_{COM}, V_{NO}, V_{NC}	Analog signal range					0		V_+	V
r_{on}	ON-state resistance	$0 \leq (V_{NC} \text{ or } V_{NO}) \leq V_+$, $I_{COM} = -32\text{ mA}$,	Switch ON, see Figure 17	25°C	3 V		7	10	Ω
				Full			12		
Δr_{on}	ON-state resistance match between channels	$V_{NC} \text{ or } V_{NO} = 2.1\text{ V}$, $I_{COM} = -32\text{ mA}$,	Switch ON, see Figure 17	25°C	3 V		0.3	0.8	Ω
				Full			1		
$r_{on(Flat)}$	ON-state resistance flatness	$0 \leq (V_{NC} \text{ or } V_{NO}) \leq V_+$, $I_{COM} = -32\text{ mA}$,	Switch ON, see Figure 17	25°C	3 V		5	7	Ω
				Full			8		
$I_{NC(OFF)}, I_{NO(OFF)}$	NC, NO OFF leakage current	$V_{NC} \text{ or } V_{NO} = 1\text{ V}$, $V_{COM} = 3\text{ V}$, or $V_{NC} \text{ or } V_{NO} = 3\text{ V}$, $V_{COM} = 1\text{ V}$,	Switch OFF, see Figure 18	25°C	3.6 V	-0.1	0.05	0.1	μA
				Full		-0.2		0.2	
$I_{NC(OFF)}, I_{NO(OFF)}$	NC, NO OFF leakage current	$V_{NC} \text{ or } V_{NO} = 0\text{ to }3.6\text{ V}$, $V_{COM} = 3.6\text{ V to }0$, or $V_{NC} \text{ or } V_{NO} = 3.6\text{ V to }0$, $V_{COM} = 0\text{ to }3.6\text{ V}$,	Switch OFF, see Figure 18	25°C	0 V	-2	0.05	2	μA
				Full		-10		10	
$I_{COM(OFF)}$	COM OFF leakage current	$V_{COM} = 1\text{ V}$, $V_{NC} \text{ or } V_{NO} = 3\text{ V}$, or $V_{COM} = 3\text{ V}$, $V_{NC} \text{ or } V_{NO} = 3\text{ V}$,	Switch OFF, see Figure 18	25°C	3.6 V	-0.1	0.05	0.1	μA
				Full		-0.2		0.2	
$I_{COM(OFF)}$	COM OFF leakage current	$V_{COM} = 0\text{ to }3.6\text{ V}$, $V_{NC} \text{ or } V_{NO} = 3.6\text{ V to }0$, or $V_{COM} = 3.6\text{ V to }0$, $V_{NC} \text{ or } V_{NO} = 0\text{ to }3.6\text{ V}$,	Switch OFF, see Figure 18	25°C	0 V	-2	0.05	2	μA
				Full		-10		10	
$I_{NC(ON)}, I_{NO(ON)}$	NC, NO ON leakage current	$V_{NC} \text{ or } V_{NO} = 1\text{ V}$, $V_{COM} = \text{Open}$, or $V_{NC} \text{ or } V_{NO} = 3\text{ V}$, $V_{COM} = \text{Open}$,	Switch ON, see Figure 19	25°C	3.6 V	-0.1	0.05	0.1	μA
				Full		-0.2		0.2	
$I_{COM(ON)}$	COM ON leakage current	$V_{COM} = 1\text{ V}$, $V_{NC} \text{ or } V_{NO} = \text{Open}$, or $V_{COM} = 3\text{ V}$, $V_{NC} \text{ or } V_{NO} = \text{Open}$,	Switch ON, see Figure 19	25°C	3.6 V	-0.1	0.05	0.1	μA
				Full		-0.2		0.2	
V_{IH}	Input logic high			Full		2		V_+	V
V_{IL}	Input logic low			Full		0		0.8	V
I_{IH}, I_{IL}	Input leakage current	$V_i = V_+ \text{ or } 0$		25°C	3.6 V	-1	0.05	1	μA
				Full		-1		1	
Q_C	Charge injection	$V_{GEN} = 0$, $R_{GEN} = 0$,	$C_L = 0.1\text{ nF}$, see Figure 26	25°C	3.3 V		2		pC
$C_{NC(OFF)}, C_{NO(OFF)}$	NC, NO OFF capacitance	$V_{NC} \text{ or } V_{NO} = V_+ \text{ or GND}$,	Switch OFF, see Figure 20	25°C	3.3 V		4.5		pF
$C_{COM(OFF)}$	COM OFF capacitance	$V_{COM} = V_+ \text{ or GND}$,	Switch OFF, see Figure 20	25°C	3.3 V		9		pF
$C_{NC(ON)}, C_{NO(ON)}$	NC, NO ON capacitance	$V_{NC} \text{ or } V_{NO} = V_+ \text{ or GND}$,	Switch ON, see Figure 20	25°C	3.3 V		16		pF
$C_{COM(ON)}$	COM ON capacitance	$V_{COM} = V_+ \text{ or GND}$,	Switch ON, see Figure 20	25°C	3.3 V		16		pF

(1) The algebraic convention is used in this data sheet; the most negative value is shown in the minimum column.

Electrical Characteristics for 3.3-V Supply (continued)
 $V_+ = 3\text{ V to }3.6\text{ V}$, $T_A = -40^\circ\text{C to }85^\circ\text{C}$ (unless otherwise noted)⁽¹⁾

PARAMETER		TEST CONDITIONS		T_A	V_+	MIN	TYP	MAX	UNIT
C_I	Digital input capacitance	$V_I = V_+$ or GND,	See Figure 20	25°C	3.3 V		3		pF
BW	Bandwidth	$R_L = 50\ \Omega$,	Switch ON, see Figure 22	25°C	3.3 V		300		MHz
O_{ISO}	OFF isolation	$R_L = 50\ \Omega$, $f = 10\text{ MHz}$,	Switch OFF, see Figure 23	25°C	3.3 V		-48		dB
X_{TALK}	Crosstalk	$R_L = 50\ \Omega$, $f = 10\text{ MHz}$,	Switch ON, see Figure 24	25°C	3.3 V		-48		dB
$X_{TALK(ADJ)}$	Crosstalk adjacent	$R_L = 50\ \Omega$, $f = 10\text{ MHz}$,	Switch ON, see Figure 25	25°C	3.3 V		-81		dB
THD	Total harmonic distortion	$R_L = 600\ \Omega$, $C_L = 50\text{ pF}$,	$f = 20\text{ Hz to }20\text{ kHz}$, see Figure 27	25°C	3.3 V		0.21%		
I_+	Positive supply current	$V_I = V_+$ or GND,	Switch ON or OFF	25°C	3.6 V		2.5	7	μA
				Full				10	

6.6 Electrical Characteristics for 2.5-V Supply
 $V_+ = 2.3\text{ V to }2.7\text{ V}$, $T_A = -40^\circ\text{C to }85^\circ\text{C}$ (unless otherwise noted)⁽¹⁾

PARAMETER		TEST CONDITIONS		T_A	V_+	MIN	TYP	MAX	UNIT
V_{COM}, V_{NC}, V_{NO}	Analog signal range					0		V_+	V
r_{on}	ON-state resistance	$0 \leq (V_{NC} \text{ or } V_{NO}) \leq V_+$, $I_{COM} = -24\text{ mA}$,	Switch ON, see Figure 17	25°C	2.3 V		12	20	Ω
				Full			22		
Δr_{on}	ON-state resistance match between channels	$V_{NC} \text{ or } V_{NO} = 1.6\text{ V}$, $I_{COM} = -24\text{ mA}$,	Switch ON, see Figure 17	25°C	2.3 V		0.3	1	Ω
				Full			2		
$r_{on(flat)}$	ON-state resistance flatness	$0 \leq (V_{NC} \text{ or } V_{NO}) \leq V_+$, $I_{COM} = -24\text{ mA}$,	Switch ON, see Figure 17	25°C	2.3 V		14	18	Ω
				Full			20		
$I_{NC(OFF)}, I_{NO(OFF)}$	NC, NO OFF leakage current	$V_{NC} \text{ or } V_{NO} = 0.5\text{ V}$, $V_{COM} = 2.2\text{ V}$, or $V_{NC} \text{ or } V_{NO} = 2.2\text{ V}$, $V_{COM} = 0.5\text{ V}$,	Switch OFF, see Figure 18	25°C	2.7 V	-0.1	0.05	0.1	μA
				Full			-0.2	0.2	
$I_{NC(OFF)}, I_{NO(OFF)}$	NC, NO OFF leakage current	$V_{NC} \text{ or } V_{NO} = 0 \text{ to } 3.6\text{ V}$, $V_{COM} = 3.6\text{ V to } 0$, or $V_{NC} \text{ or } V_{NO} = 3.6\text{ V to } 0$, $V_{COM} = 0 \text{ to } 3.6\text{ V}$,	Switch OFF, see Figure 18	25°C	0 V	-2	0.05	2	μA
				Full			-10	10	
$I_{COM(OFF)}$	COM OFF leakage current	$V_{COM} = 0.5\text{ V}$, $V_{NC} \text{ or } V_{NO} = 2.2\text{ V}$, or $V_{COM} = 2.2\text{ V}$, $V_{NC} \text{ or } V_{NO} = 0.5\text{ V}$,	Switch OFF, see Figure 18	25°C	2.7 V	-0.1	0.05	0.1	μA
				Full			-0.2	0.2	
$I_{COM(OFF)}$	COM OFF leakage current	$V_{COM} = 0 \text{ to } 3.6\text{ V}$, $V_{NC} \text{ or } V_{NO} = 3.6\text{ V to } 0$, or $V_{COM} = 3.6\text{ V to } 0$, $V_{NC} \text{ or } V_{NO} = 0 \text{ to } 3.6\text{ V}$,	Switch OFF, see Figure 18	25°C	0 V	-2	0.05	2	μA
				Full			-10	10	
$I_{NC(ON)}, I_{NO(ON)}$	NC, NO ON leakage current	$V_{NC} \text{ or } V_{NO} = 0.5\text{ V}$, $V_{COM} = \text{Open}$, or $V_{NC} \text{ or } V_{NO} = 2.2\text{ V}$, $V_{COM} = \text{Open}$,	Switch ON, see Figure 19	25°C	2.7 V	-0.1	0.05	0.1	μA
				Full			-0.2	0.2	
$I_{COM(ON)}$	COM ON leakage current	$V_{COM} = 0.5\text{ V}$, $V_{NC} \text{ or } V_{NO} = \text{Open}$, or $V_{COM} = 2.2\text{ V}$, $V_{NC} \text{ or } V_{NO} = \text{Open}$,	Switch ON, see Figure 19	25°C	2.7 V	-0.1	0.05	0.1	μA
				Full			-0.2	0.2	
V_{IH}	Input logic high			Full		1.7		V_+	V
V_{IL}	Input logic low			Full		0		0.7	V

(1) The algebraic convention is used in this data sheet; the most negative value is shown in the minimum column.

Electrical Characteristics for 2.5-V Supply (continued)

 $V_+ = 2.3 \text{ V to } 2.7 \text{ V}$, $T_A = -40^\circ\text{C to } 85^\circ\text{C}$ (unless otherwise noted)⁽¹⁾

PARAMETER	TEST CONDITIONS	T_A	V_+	MIN	TYP	MAX	UNIT	
I_{IH} , I_{IL}	Input leakage current	$V_I = V_+$ or 0	25°C	2.7 V	-0.1	0.05	0.1	μA
			Full		-1	1		
Q_C	Charge injection	$V_{GEN} = 0$, $R_{GEN} = 0$,	$C_L = 0.1 \text{ nF}$, see Figure 26	25°C	2.5 V	1	pC	
$C_{NC(OFF)}$, $C_{NO(OFF)}$	NC, NO OFF capacitance	V_{NC} or $V_{NO} = V_+$ or GND,	Switch OFF, see Figure 20	25°C	2.5 V	3	pF	
$C_{COM(OFF)}$	COM OFF capacitance	$V_{COM} = V_+$ or GND,	Switch OFF, see Figure 20	25°C	2.5 V	9	pF	
$C_{NC(ON)}$, $C_{NO(ON)}$	NC, NO ON capacitance	V_{NC} or $V_{NO} = V_+$ or GND,	Switch ON, see Figure 20	25°C	2.5 V	16	pF	
$C_{COM(ON)}$	COM ON capacitance	$V_{COM} = V_+$ or GND,	Switch ON, see Figure 20	25°C	2.5 V	16	pF	
C_I	Digital input capacitance	$V_I = V_+$ or GND,	See Figure 20	25°C	2.5 V	3	pF	
BW	Bandwidth	$R_L = 50 \Omega$,	Switch ON, see Figure 22	25°C	2.5 V	300	MHz	
O_{ISO}	OFF isolation	$R_L = 50 \Omega$, $f = 10 \text{ MHz}$,	Switch OFF, see Figure 23	25°C	2.5 V	-48	dB	
X_{TALK}	Crosstalk	$R_L = 50 \Omega$, $f = 10 \text{ MHz}$,	Switch ON, see Figure 24	25°C	2.5 V	-48	dB	
$X_{TALK(ADJ)}$	Crosstalk adjacent	$R_L = 50 \Omega$, $f = 10 \text{ MHz}$,	Switch ON, see Figure 25	25°C	3.3 V	-81	dB	
THD	Total harmonic distortion	$R_L = 600 \Omega$, $C_L = 50 \text{ pF}$,	$f = 20 \text{ Hz to } 20 \text{ kHz}$, see Figure 27	25°C	2.5 V	0.33%		
I_+	Positive supply current	$V_I = V_+$ or GND,	Switch ON or OFF	25°C	2.7 V	2.5	7	μA
				Full		10		

6.7 Electrical Characteristics for 2.1-V Supply

 $V_+ = 2.00 \text{ V to } 2.20 \text{ V}$, $T_A = -40^\circ\text{C to } 85^\circ\text{C}$ (unless otherwise noted)⁽¹⁾

PARAMETER	TEST CONDITIONS	T_A	V_+	MIN	TYP	MAX	UNIT
V_{IH}	Input logic high	Full		1.2		4.3	V
V_{IL}	Input logic low	Full		0		0.5	V

(1) The algebraic convention is used in this data sheet; the most negative value is shown in the minimum column.

6.8 Electrical Characteristics for 1.8-V Supply

 $V_+ = 1.65 \text{ V to } 1.95 \text{ V}$, $T_A = -40^\circ\text{C to } 85^\circ\text{C}$ (unless otherwise noted)⁽¹⁾

PARAMETER	TEST CONDITIONS	T_A	V_+	MIN	TYP	MAX	UNIT	
V_{COM} , V_{NC} , V_{NO}	Analog signal range			0		V_+	V	
r_{on}	ON-state resistance	$0 \leq (V_{NC} \text{ or } V_{NO}) \leq V_+$, $I_{COM} = -32 \text{ mA}$,	Switch ON, see Figure 17	25°C	1.65 V	5.5	17	Ω
				Full		32		
Δr_{on}	ON-state resistance match between channels	V_{NC} or $V_{NO} = 1.5 \text{ V}$, $I_{COM} = -32 \text{ mA}$,	Switch ON, see Figure 17	25°C	1.65 V	0.3	1	Ω
				Full		1.2		
$r_{on(Flat)}$	ON-state resistance flatness	$0 \leq (V_{NC} \text{ or } V_{NO}) \leq V_+$, $I_{COM} = -32 \text{ mA}$,	Switch ON, see Figure 17	25°C	1.65 V	2.7	5.5	Ω
				Full		7.3		

(1) The algebraic convention is used in this data sheet; the most negative value is shown in the minimum column.

Electrical Characteristics for 1.8-V Supply (continued)
 $V_+ = 1.65\text{ V to }1.95\text{ V}$, $T_A = -40^\circ\text{C to }85^\circ\text{C}$ (unless otherwise noted)⁽¹⁾

PARAMETER	TEST CONDITIONS	T_A	V_+	MIN	TYP	MAX	UNIT
$I_{NC(OFF)}$, $I_{NO(OFF)}$	V_{NC} or $V_{NO} = 0.3\text{ V}$, $V_{COM} = 1.65\text{ V}$, or V_{NC} or $V_{NO} = 1.65\text{ V}$, $V_{COM} = 0.3\text{ V}$, Switch OFF, see Figure 18	25°C	1.95 V	-0.25	0.03	0.25	μA
		Full		-4.5		4.5	
	V_{NC} or $V_{NO} = 1.95\text{ V to }0\text{ V}$, $V_{COM} = 0\text{ V to }1.95\text{ V}$, or V_{NC} or $V_{NO} = 0\text{ V to }1.95\text{ V}$, $V_{COM} = 1.95\text{ V to }0\text{ V}$, Switch OFF, see Figure 18	25°C	0 V	-0.4	0.01	0.4	
		Full		-6.5		6.5	
$I_{COM(OFF)}$	$V_{COM} = 1.65\text{ V}$, V_{NC} or $V_{NO} = 0.3\text{ V}$, or $V_{COM} = 0.3\text{ V}$, V_{NC} or $V_{NO} = 1.65\text{ V}$, Switch OFF, see Figure 18	25°C	1.95 V	-0.4	0.02	0.4	μA
		Full		-0.9		0.9	
	$V_{COM} = 0\text{ V to }1.95\text{ V}$, V_{NC} or $V_{NO} = 1.95\text{ V to }0\text{ V}$, or $V_{COM} = 1.95\text{ V to }0$, V_{NC} or $V_{NO} = 0\text{ to }1.95\text{ V}$, Switch OFF, see Figure 18	25°C	0 V	-0.4	0.02	0.4	
		Full		-4.5		4.5	
$I_{NC(ON)}$, $I_{NO(ON)}$	V_{NC} or $V_{NO} = 0.3\text{ V}$, $V_{COM} = \text{Open}$, or V_{NC} or $V_{NO} = 1.65\text{ V}$, $V_{COM} = \text{Open}$, Switch ON, see Figure 19	25°C	1.95 V	-2	0.02	2	μA
		Full		-2	0.02	2	
$I_{COM(ON)}$	$V_{COM} = 0.3\text{ V}$, V_{NC} or $V_{NO} = \text{Open}$, or $V_{COM} = 1.65\text{ V}$, V_{NC} or $V_{NO} = \text{Open}$, Switch ON, see Figure 19	25°C	1.95 V	-4.5		4.5	μA
		Full					
V_{IH}	Input logic high	Full	1.95 V	1		3.6	V
V_{IL}	Input logic low	Full	1.95 V	0		0.4	V
I_{IH} , I_{IL}	Input leakage current	25°C	1.95 V	-0.1	0.01	0.1	μA
		Full		-2.1		2.1	

6.9 Switching Characteristics for 3.3-V Supply

over operating free-air temperature range (unless otherwise noted)

PARAMETER	TEST CONDITIONS	T_A	V_+	MIN	TYP	MAX	UNIT
t_{ON}	$V_{COM} = 2\text{ V}$, $R_L = 300\ \Omega$, $C_L = 35\text{ pF}$, see Figure 21	25°C	3.3 V	2.5	3.5	8	ns
		Full	3 V to 3.6 V	2.5		9	
t_{OFF}	$V_{COM} = 2\text{ V}$, $R_L = 300\ \Omega$, $C_L = 35\text{ pF}$, see Figure 21	25°C	3.3 V	0.5	2	6.5	ns
		Full	3 V to 3.6 V	0.5		7	

6.10 Switching Characteristics for 2.5-V Supply

over operating free-air temperature range (unless otherwise noted)

PARAMETER	TEST CONDITIONS	T_A	V_+	MIN	TYP	MAX	UNIT
t_{ON}	$V_{COM} = 1.5\text{ V}$, $R_L = 300\ \Omega$, $C_L = 35\text{ pF}$, see Figure 21	25°C	2.5 V	2.5	5	9.5	ns
		Full	2.3 V to 2.7 V	2.5		10.5	
t_{OFF}	$V_{COM} = 1.5\text{ V}$, $R_L = 300\ \Omega$, $C_L = 35\text{ pF}$, see Figure 21	25°C	2.5 V	0.5	3	7.5	ns
		Full	2.3 V to 2.7 V	0.5		9	

6.11 Switching Characteristics for 1.8-V Supply

over operating free-air temperature range (unless otherwise noted)

PARAMETER		TEST CONDITIONS		T _A	V ₊	MIN	TYP	MAX	UNIT
t _{ON}	Turnon time	V _{COM} = V ₊ , R _L = 50 Ω,	C _L = 35 pF, see Figure 21	25°C	1.8 V		14.1	49.3	ns
				Full	1.65 V to 1.95 V		49.3	56.7	
t _{OFF}	Turnoff time	V _{COM} = V ₊ , R _L = 50 Ω,	C _L = 35 pF, see Figure 21	25°C	1.8 V		16.1	26.5	ns
				Full	1.65 V to 1.95 V			31.2	
t _{BBM}	Break-before- make time	V _{NC} = V _{NO} = V ₊ /2, R _L = 50 Ω,	C _L = 35 pF, see Figure 21	25°C	1.8 V	5.3	18.4	58	ns
				Full	1.65 V to 1.95 V			58	

6.12 Typical Characteristics

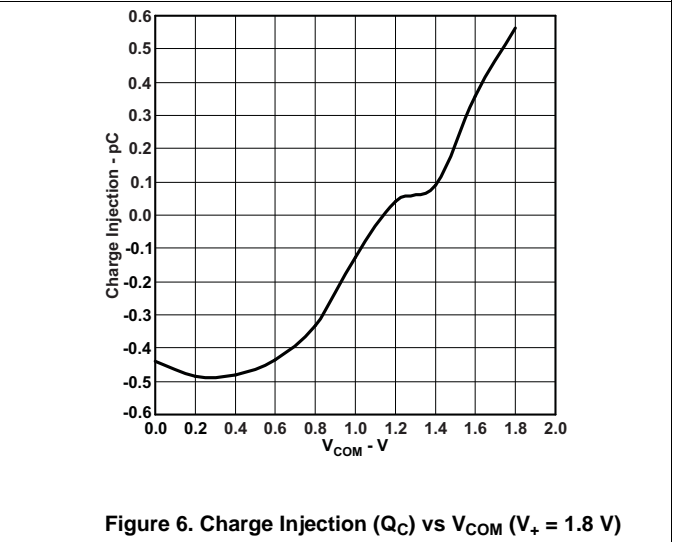
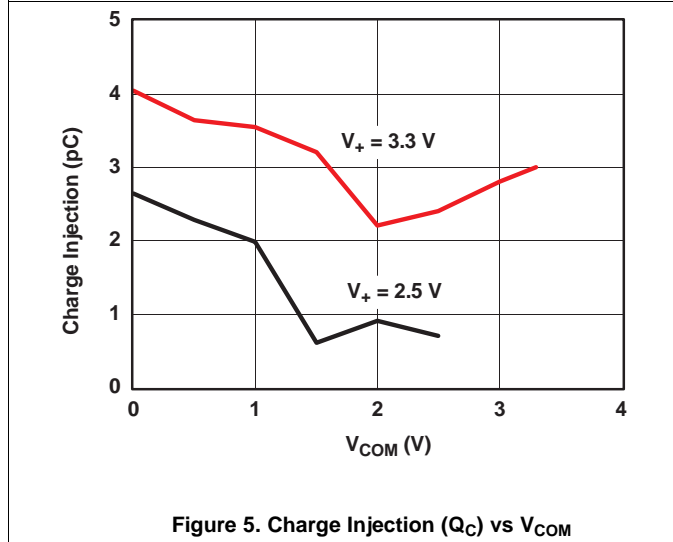
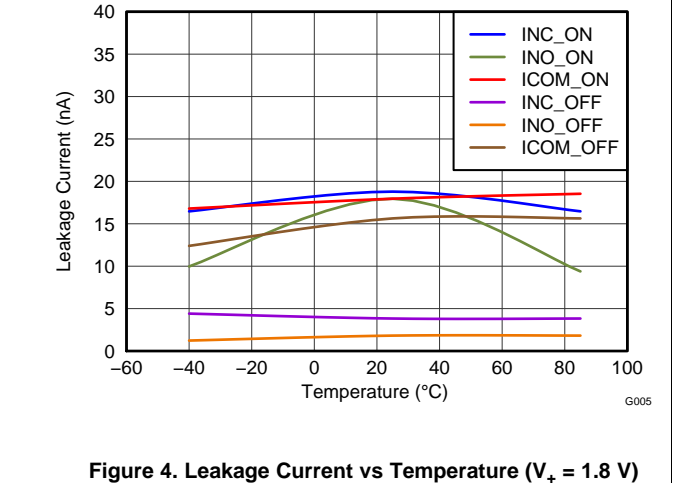
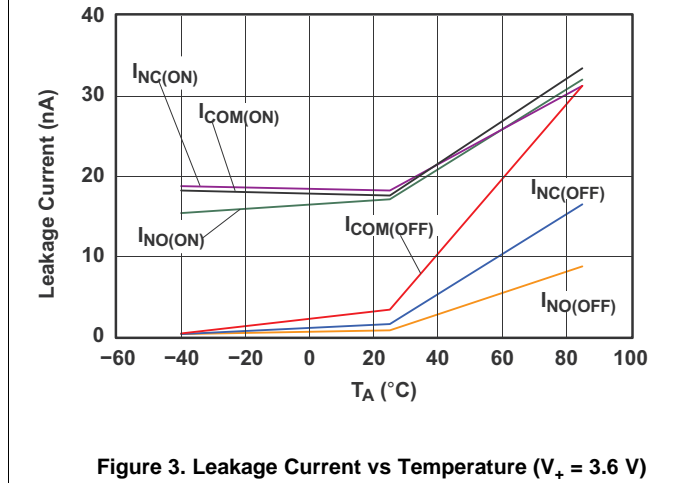
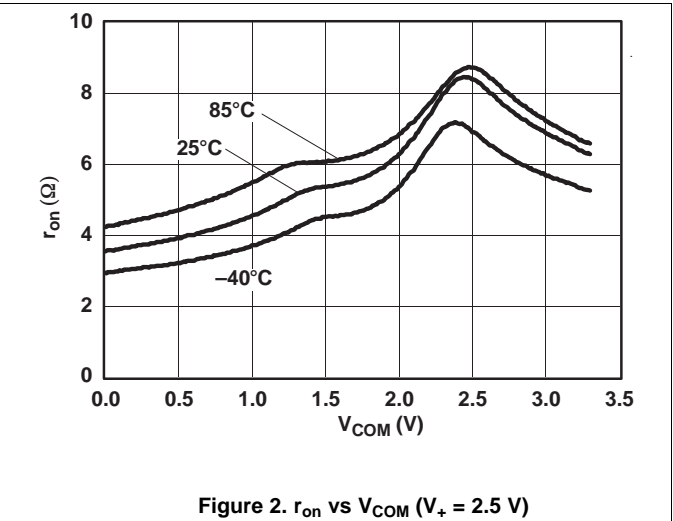
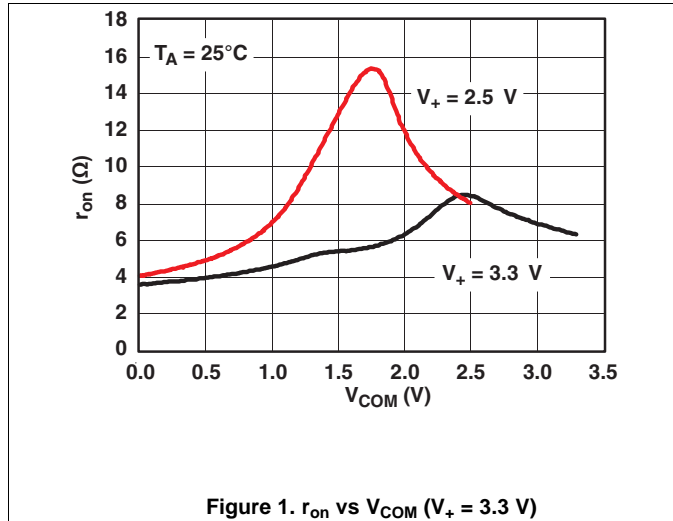

Typical Characteristics (continued)

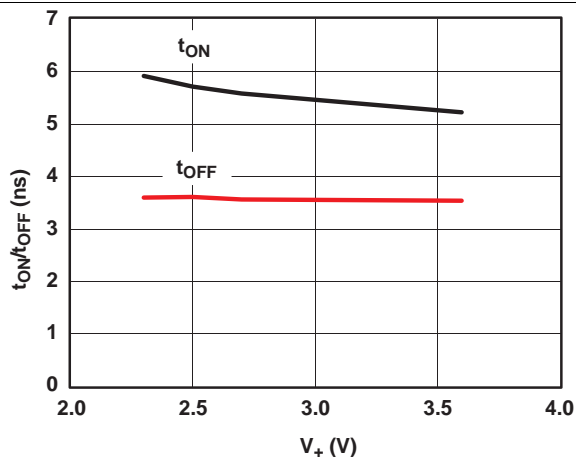

Figure 7. t_{ON} and t_{OFF} vs Supply Voltage

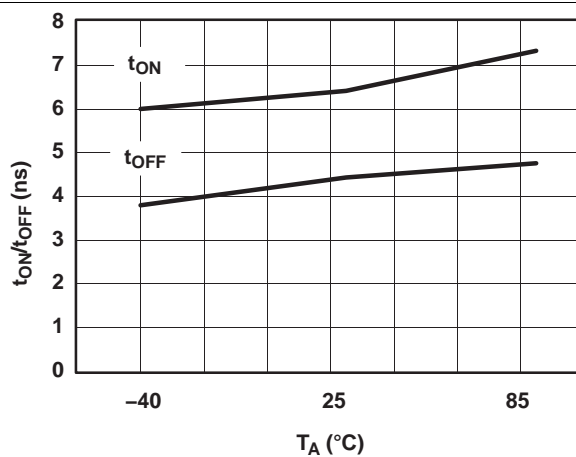

Figure 8. t_{ON} and t_{OFF} vs Temperature ($V_+ = 3.3$ V)

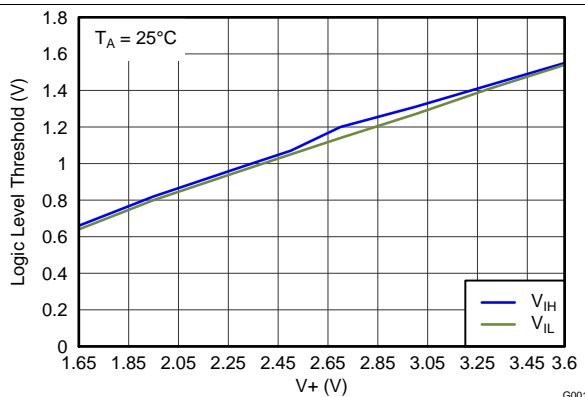

Figure 9. Logic-Level Threshold vs V_+

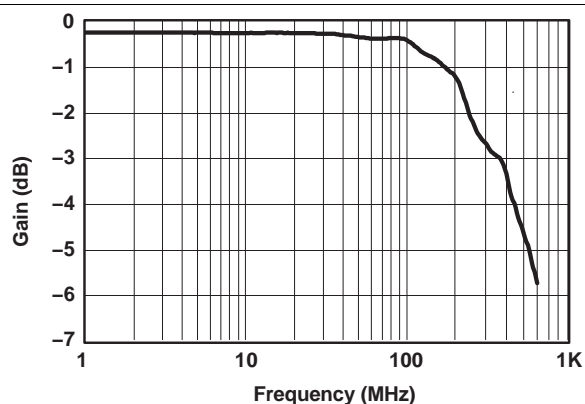

Figure 10. Gain vs Frequency Bandwidth ($V_+ = 3.3$ V)

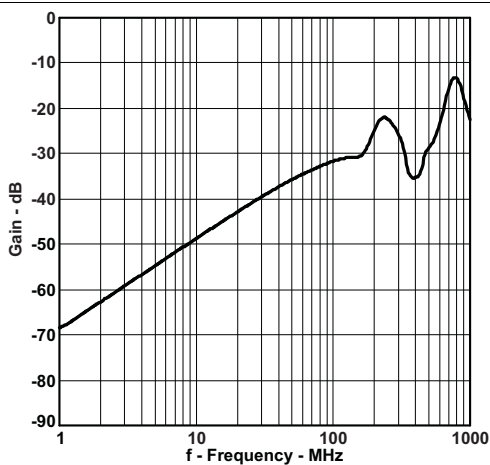

Figure 11. OFF Isolation vs Frequency ($V_+ = 1.8$ V)

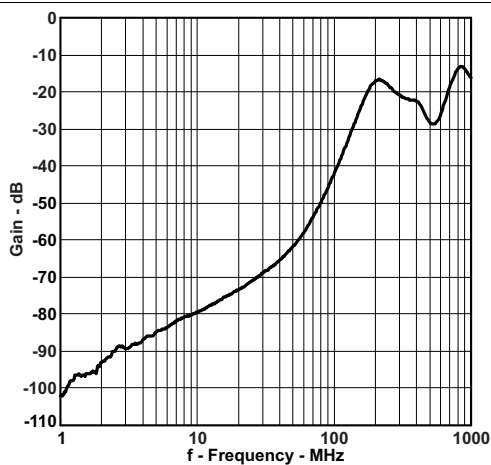

Figure 12. Crosstalk Adjacent vs Frequency ($V_+ = 1.8$ V)

Typical Characteristics (continued)

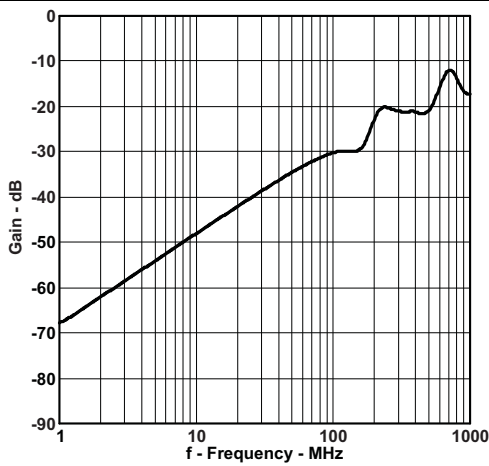

Figure 13. Crosstalk vs Frequency ($V_+ = 1.8\text{ V}$)

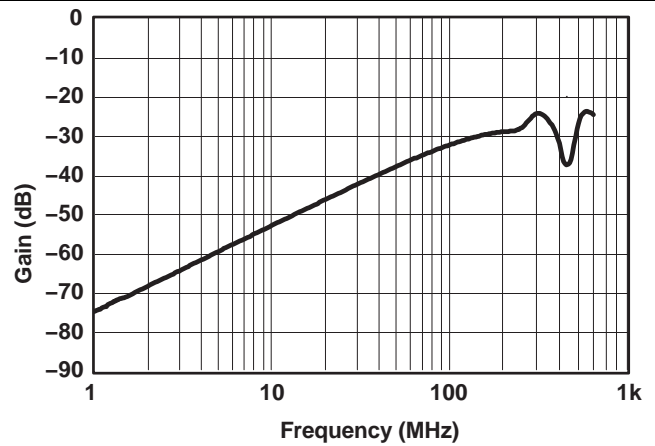

Figure 14. OFF Isolation vs Frequency ($V_+ = 3.3\text{ V}$)

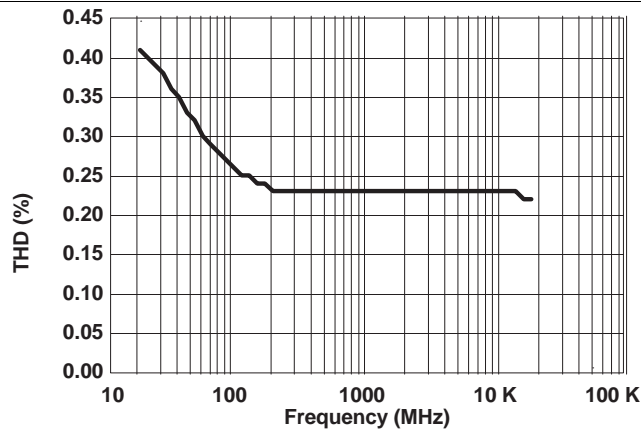

Figure 15. Total Harmonic Distortion vs Frequency

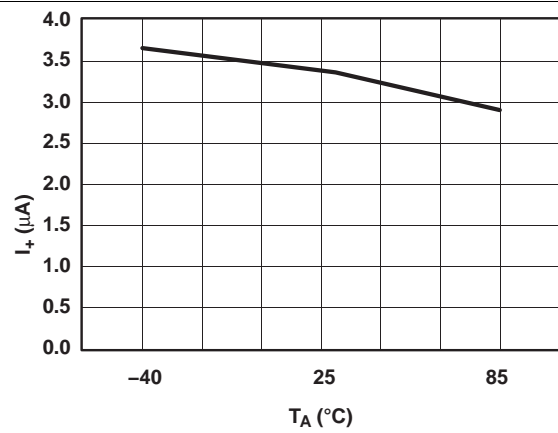

Figure 16. Power-Supply Current vs Temperature ($V_+ = 3.3\text{ V}$)

7 Parameter Measurement Information

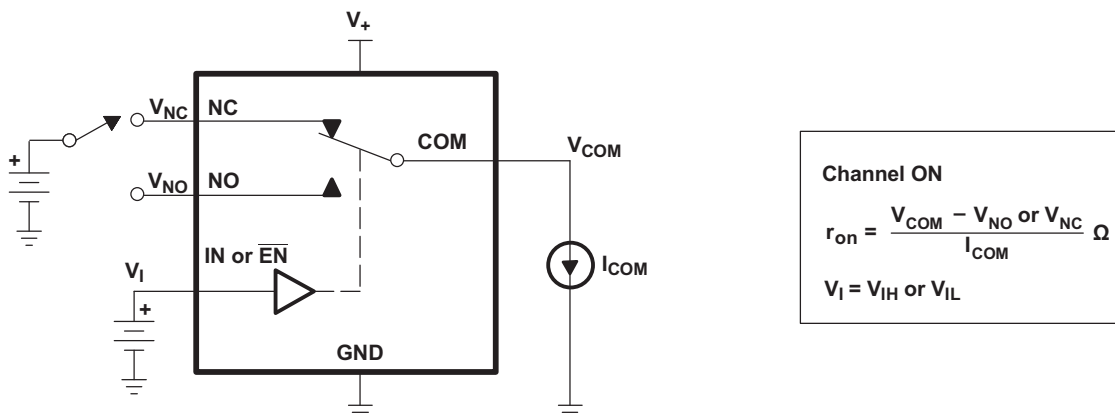

Figure 17. ON-State Resistance (r_{on})

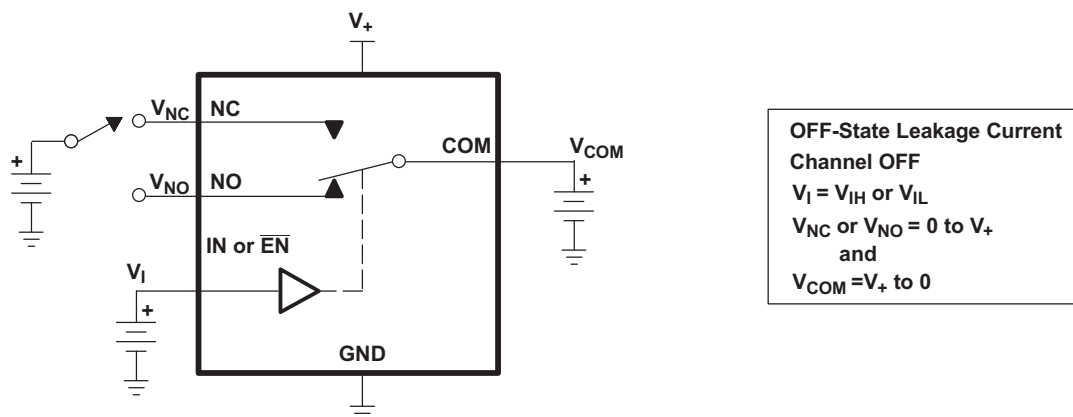

Figure 18. OFF-State Leakage Current ($I_{COM(OFF)}$, $I_{NC(OFF)}$, $I_{NO(OFF)}$)

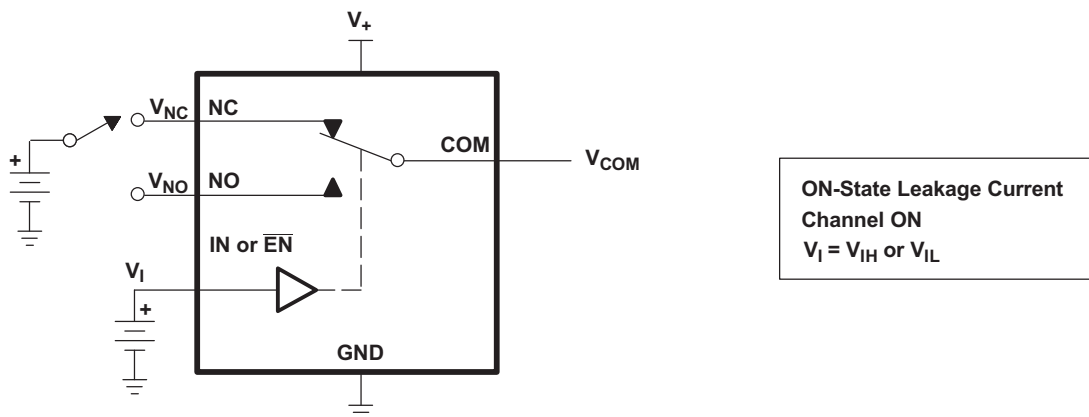

Figure 19. ON-State Leakage Current ($I_{COM(ON)}$, $I_{NC(ON)}$)

Parameter Measurement Information (continued)

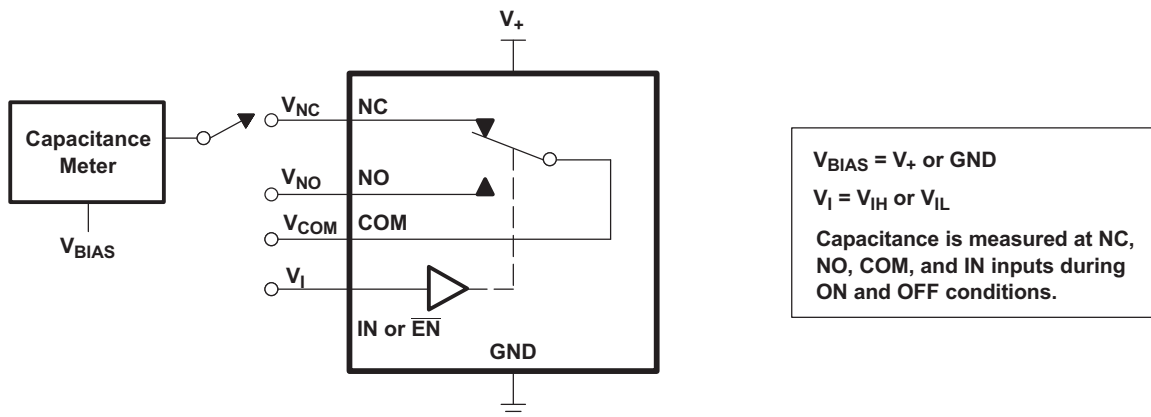
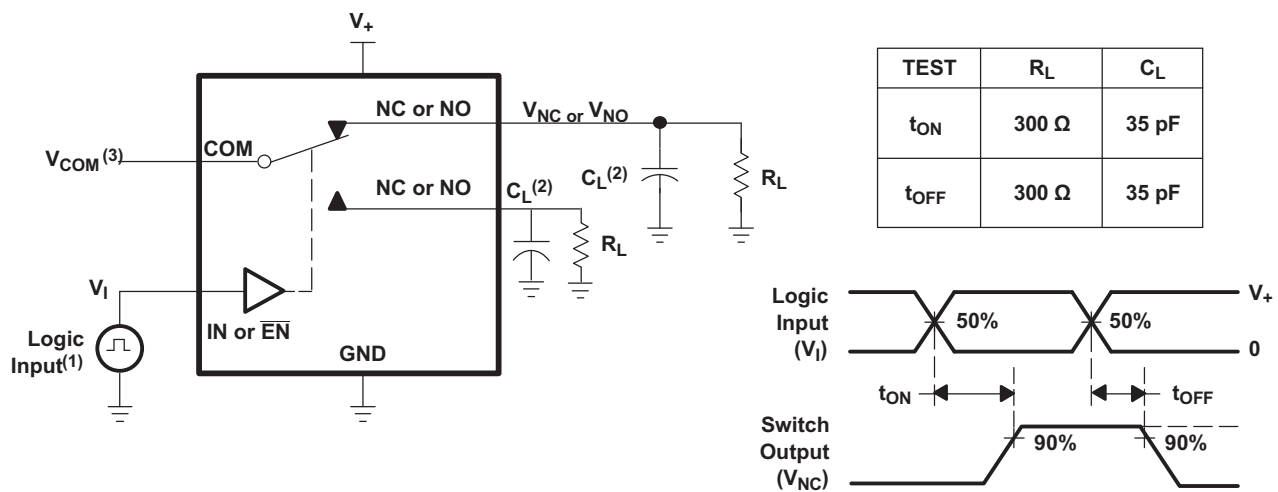

Figure 20. Capacitance (C_I , $C_{COM(OFF)}$, $C_{COM(ON)}$, $C_{NC(OFF)}$, $C_{NC(ON)}$)



- (1) All input pulses are supplied by generators having the following characteristics: PRR \leq 10 MHz, $Z_O = 50 \Omega$, $t_r < 5$ ns, $t_f < 5$ ns.
- (2) C_L includes probe and jig capacitance.
- (3) See Electrical Characteristics for V_{COM} .

Figure 21. Turnon (t_{ON}) and Turnoff Time (t_{OFF})

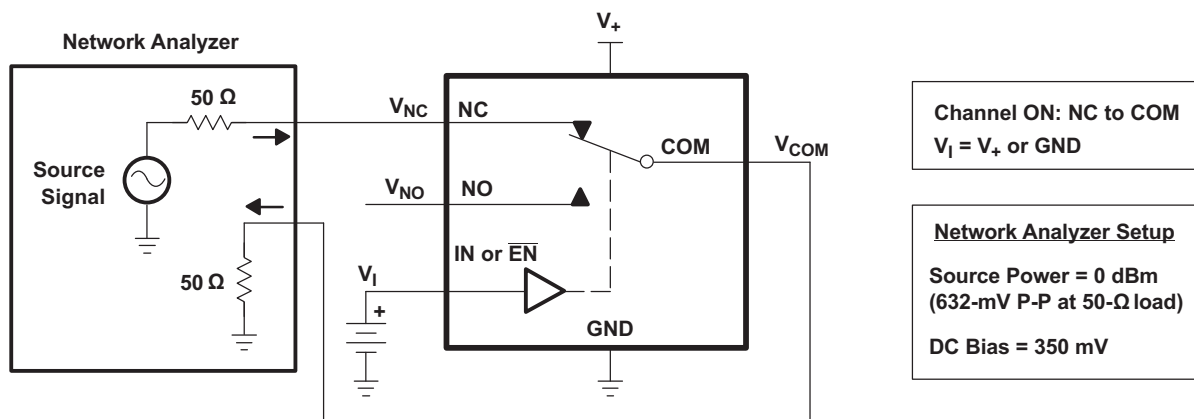

Figure 22. Bandwidth (BW)

Parameter Measurement Information (continued)

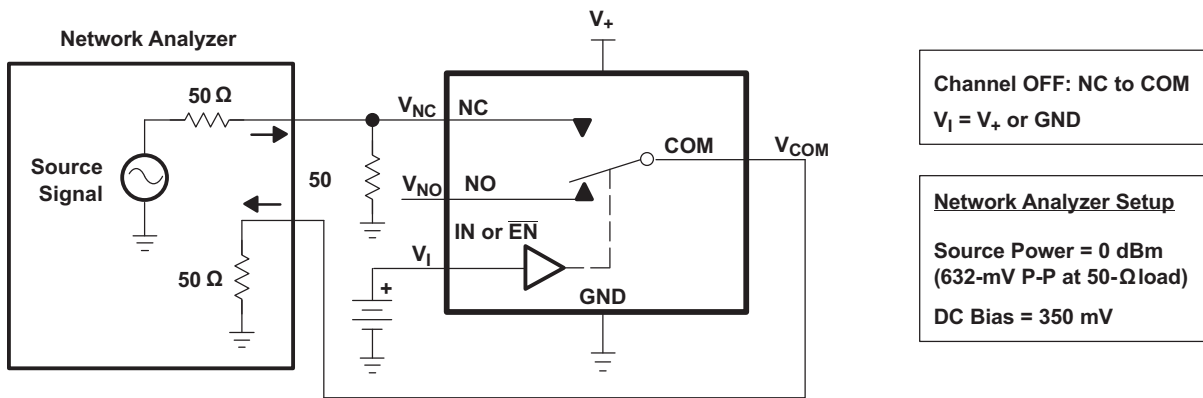

Figure 23. OFF Isolation (O_{ISO})

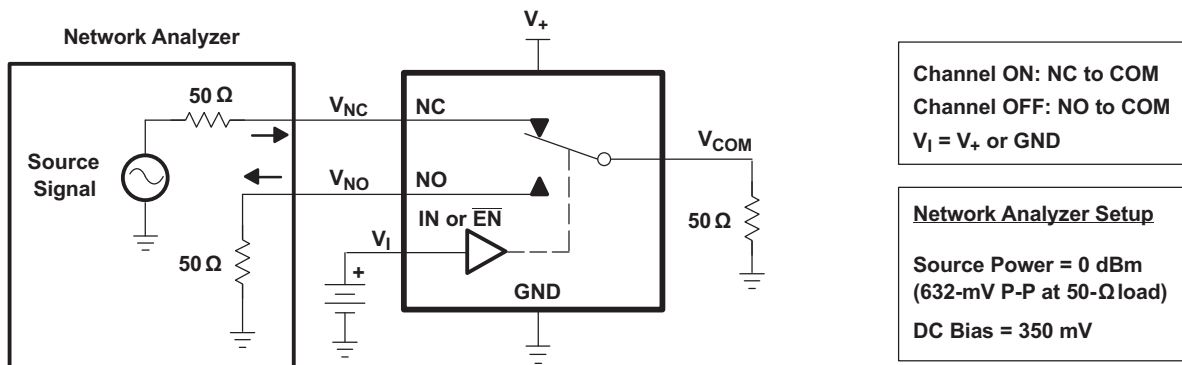

Figure 24. Crosstalk (X_{TALK})

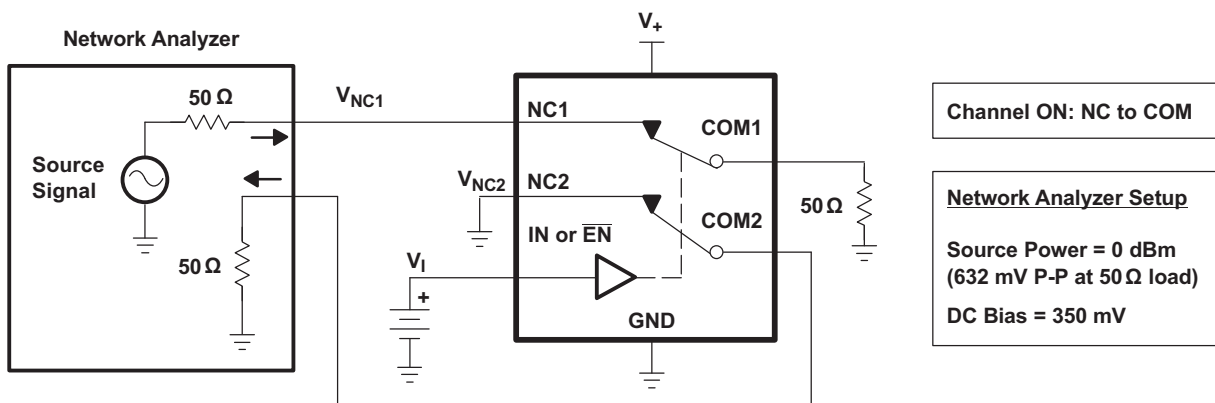
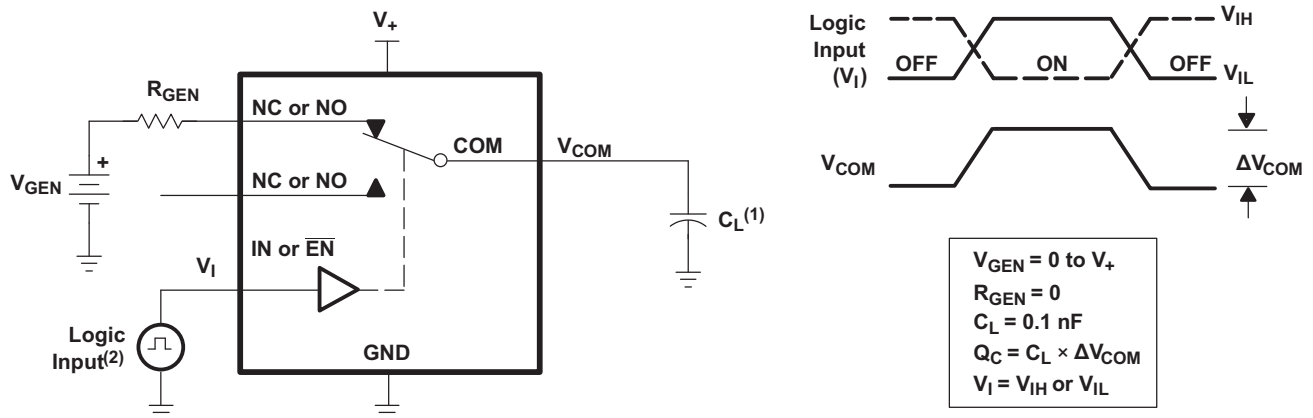

Figure 25. Crosstalk Adjacent

Parameter Measurement Information (continued)



- (1) C_L includes probe and jig capacitance.
- (2) All input pulses are supplied by generators having the following characteristics: $PRR \leq 10 \text{ MHz}$, $Z_O = 50 \Omega$, $t_r < 5 \text{ ns}$, $t_f < 5 \text{ ns}$.

Figure 26. Charge Injection (Q_C)

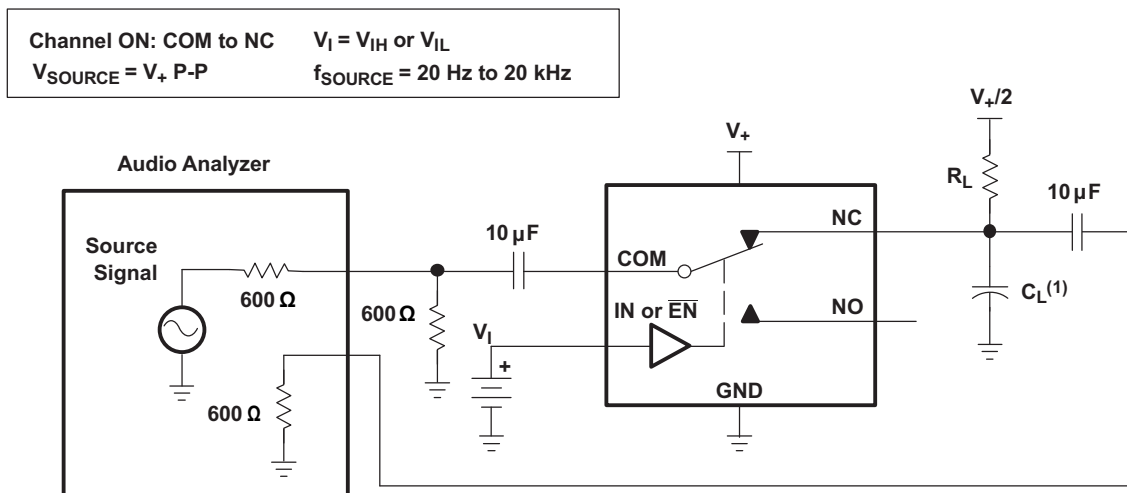

- (1) C_L includes probe and jig capacitance.

Figure 27. Total Harmonic Distortion (THD)

8 Detailed Description

8.1 Overview

The TS3A5018 is a quad single-pole-double-throw (SPDT) solid-state analog switch. The TS3A5018, like all analog switches, is bidirectional. When powered on, each COM pin is connected to its respective NC pin. For this device, NC stands for *normally closed* and NO stands for *normally open*. The switch is enabled when \overline{EN} is low. If IN is also low, COM is connected to NC. If IN is high, COM is connected to NO.

The TS3A5018 is a break-before-make switch. This means that during switching, a connection is broken before a new connection is established. The NC and NO pins are never connected to each other.

8.2 Functional Block Diagram (Each Switch)

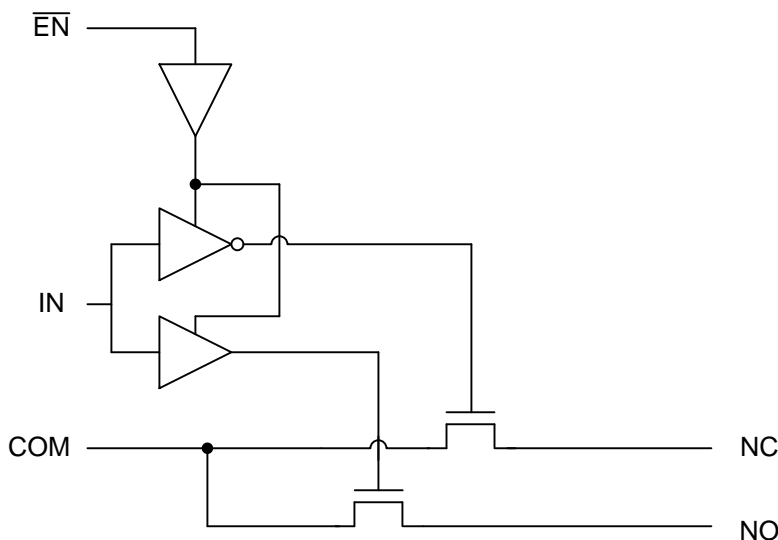

8.3 Feature Description

The low ON-state resistance, ON-state resistance matching, and charge injection in the TS3A5018 make this switch an excellent choice for analog signals that require minimal distortion. In addition, the low THD allows audio signals to be preserved more clearly as they pass through the device.

The 1.8-V to 3.6-V operation allows compatibility with more logic levels, and the bidirectional I/Os can pass analog signals from 0 V to V_+ with low distortion.

8.4 Device Functional Modes

Table 1. Function Table

\overline{EN}	IN	NO TO COM, COM TO NO	NC TO COM, COM TO NC
L	L	OFF	ON
L	H	ON	OFF
H	X	OFF	OFF

9 Application and Implementation

NOTE

Information in the following applications sections is not part of the TI component specification, and TI does not warrant its accuracy or completeness. TI's customers are responsible for determining suitability of components for their purposes. Customers should validate and test their design implementation to confirm system functionality.

9.1 Application Information

The TS3A5018 can be used in a variety of customer systems. The TS3A5018 can be used anywhere multiple analog or digital signals must be selected to pass across a single line.

9.2 Typical Application

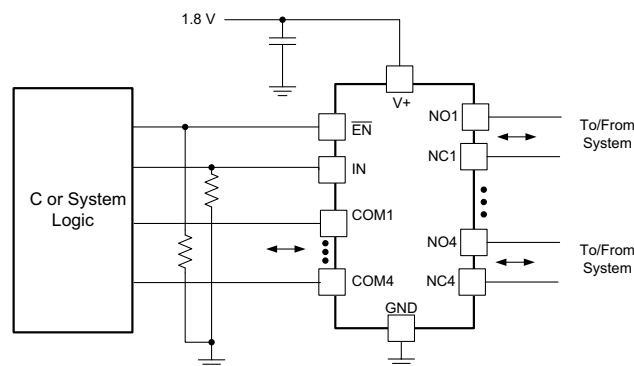

Figure 28. System Schematic for TS3A5018

9.2.1 Design Requirements

In this particular application, V_+ was 1.8 V, although V_+ is allowed to be any voltage specified in [Recommended Operating Conditions](#). A decoupling capacitor is recommended on the V_+ pin. See [Power Supply Recommendations](#) for more details.

9.2.2 Detailed Design Procedure

In this application, \overline{EN} and IN are, by default, pulled low to GND. Choose these resistor sizes based on the current driving strength of the GPIO, the desired power consumption, and the switching frequency (if applicable). If the GPIO is open-drain, use pullup resistors instead.

9.2.3 Application Curve

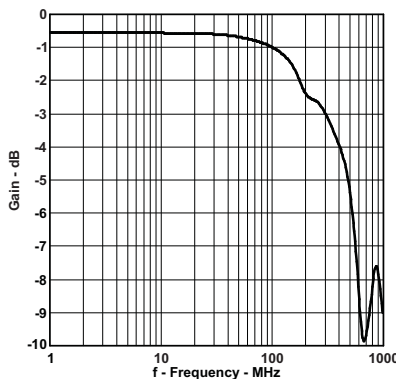

Figure 29. Gain vs Frequency Bandwidth ($V_+ = 1.8$ V)

10 Power Supply Recommendations

The power supply can be any voltage between the minimum and maximum supply voltage rating located in the [Recommended Operating Conditions](#).

Each V_{CC} terminal should have a good bypass capacitor to prevent power disturbance. For devices with a single supply, a 0.1- μF bypass capacitor is recommended. If there are multiple pins labeled V_{CC} , then a 0.01- μF or 0.022- μF capacitor is recommended for each V_{CC} because the V_{CC} pins will be tied together internally. For devices with dual supply pins operating at different voltages, for example V_{CC} and V_{DD} , a 0.1- μF bypass capacitor is recommended for each supply pin. It is acceptable to parallel multiple bypass capacitors to reject different frequencies of noise. 0.1- μF and 1- μF capacitors are commonly used in parallel. The bypass capacitor should be installed as close to the power terminal as possible for best results.

11 Layout

11.1 Layout Guidelines

Reflections and matching are closely related to loop antenna theory, but different enough to warrant their own discussion. When a PCB trace turns a corner at a 90° angle, a reflection can occur. This is primarily due to the change of width of the trace. At the apex of the turn, the trace width is increased to 1.414 times its width. This upsets the transmission line characteristics, especially the distributed capacitance and self-inductance of the trace — resulting in the reflection. It is a given that not all PCB traces can be straight, and so they will have to turn corners. [Figure 30](#) shows progressively better techniques of rounding corners. Only the last example maintains constant trace width and minimizes reflections.

Unused switch I/Os, such as NO, NC, and COM, can be left floating or tied to GND. However, the IN and $\overline{\text{EN}}$ pins must be driven high or low. Due to partial transistor turnon when control inputs are at threshold levels, floating control inputs can cause increased I_{CC} or unknown switch selection states.

11.2 Layout Example

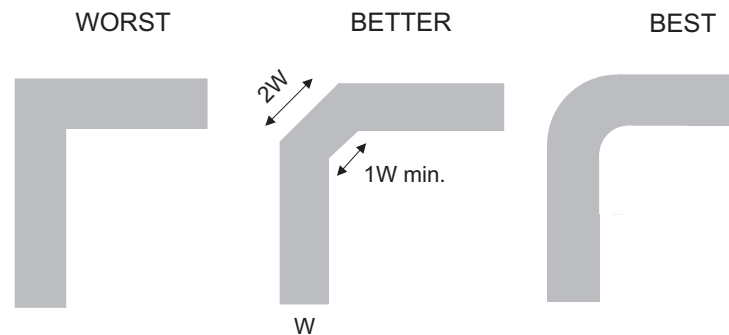

Figure 30. Trace Example

12 器件和文档支持

12.1 器件支持

12.1.1 器件命名规则

表 2. 参数 说明

符号	说明
V_{COM}	COM 处的电压
V_{NC}	NC 处的电压
V_{NO}	NO 处的电压
r_{on}	通道打开时 COM 和 NC 或 NO 端口之间的电阻
Δr_{on}	特定器件中通道间 r_{on} 的差值
$r_{on(Flat)}$	额定条件范围下, 同一通道内 r_{on} 最大值与最小值之间的差值
$I_{NC(OFF)}$	相应通道 (NC 到 COM) 处于关断状态时, 在 NC 端口测得的泄漏电流
$I_{NC(ON)}$	相应通道 (NC 到 COM) 处于导通状态且输出 (COM) 处于开路状态时, 在 NC 端口测得的泄漏电流
$I_{NO(OFF)}$	相应通道 (NO 到 COM) 处于关断状态时, 在 NO 端口测得的泄漏电流
$I_{NO(ON)}$	相应通道 (NO 到 COM) 处于导通状态且输出 (COM) 处于开路状态时, 在 NO 端口测得的泄漏电流
$I_{COM(OFF)}$	相应通道 (COM 到 NC 或 NO) 处于关断状态时, 在 COM 端口测得的泄漏电流
$I_{COM(ON)}$	相应通道 (COM 到 NC 或 NO) 处于导通状态且输出 (NC 或 NO) 处于开路状态时, 在 COM 端口测得的泄漏电流
V_{IH}	控制输入 (IN, \overline{EN}) 逻辑高电平的最小输入电压
V_{IL}	控制输入 (IN, \overline{EN}) 逻辑低电平的最大输入电压
V_I	控制输入 (IN, \overline{EN}) 处的电压
I_{IH}, I_{IL}	控制输入 (IN, \overline{EN}) 处测量的泄漏电流
t_{ON}	开关开通时间。此参数是在特定条件范围下, 开关开通时, 通过数字控制 (IN) 信号和模拟输出 (NC 或 NO) 信号之间的传播延迟测量得出。
t_{OFF}	开关关断时间。此参数是在特定条件范围下, 开关关断时, 通过数字控制 (OFF) 信号和模拟输出 (NC 或 NO) 信号之间的传播延迟测量得出。
Q_C	电荷注入是测量从控制 (IN) 输入到模拟 (NC 或 NO) 输入产生的不需要的信号耦合的方法。电荷注入以库仑为单位, 可通过测量开关控制输入产生的总感应电荷得出该值。电荷注入, $Q_C = C_L \times \Delta V_{COM}$, C_L 是负载电容, ΔV_{COM} 是模拟输出电压的变化。
$C_{NC(OFF)}$	相应通道 (NC 到 COM) 关闭时 NC 端口的电容
$C_{NC(ON)}$	相应通道 (NC 到 COM) 开启时 NC 端口的电容
$C_{NO(OFF)}$	相应通道 (NO 到 COM) 关闭时 NO 端口的电容
$C_{NO(ON)}$	相应通道 (NO 到 COM) 开启时 NO 端口的电容
$C_{COM(OFF)}$	相应通道 (COM 到 NC) 关闭时 COM 端口的电容
$C_{COM(ON)}$	相应通道 (COM 到 NC) 开启时 COM 端口的电容
C_I	控制输入 (IN, \overline{EN}) 电容
O_{ISO}	开关关断隔离用于衡量关断状态开关阻抗的大小。关断隔离以 dB 为单位, 当相应通道 (NC 到 COM) 处于关断状态时, 在额定频率下测量得出。
X_{TALK}	串扰是测量从开启状态的通道到关断状态的通道 (NC1 到 NO1) 产生的不必要信号耦合的方法。相邻串扰是测量从一条开启状态的通道到相邻开启状态的通道 (NC1 到 NC2) 产生的不必要信号耦合的方法。相邻串扰在额定频率下测量得出且以 dB 为单位。
BW	开关带宽。这是导通通道增益低于直流增益 -3dB 时的频率。
THD	总谐波失真用于描述由模拟开关导致的信号失真。其定义为二次、三次甚至多次谐波与基波绝对幅度之比的均方根 (RMS) 值。
I_+	静态电源电流, 以及 V_+ 或 GND 的控制 (IN) 引脚

12.2 文档支持

12.2.1 相关文档

如需相关文档, 请参阅:

文档支持 (接下页)

- 《CMOS 输入缓慢变化或悬空的影响》，SCBA004

12.3 接收文档更新通知

要接收文档更新通知，请导航至 TI.com.cn 上的器件产品文件夹。单击右上角的 *通知我* 进行注册，即可每周接收产品信息更改摘要。有关更改的详细信息，请查看任何已修订文档中包含的修订历史记录。

12.4 社区资源

下列链接提供到 TI 社区资源的连接。链接的内容由各个分销商“按照原样”提供。这些内容并不构成 TI 技术规范，并且不一定反映 TI 的观点；请参阅 TI 的《使用条款》。

TI E2E™ 在线社区 *TI 的工程师对工程师 (E2E) 社区*。此社区的创建目的在于促进工程师之间的协作。在 e2e.ti.com 中，您可以咨询问题、分享知识、拓展思路并与同行工程师一道帮助解决问题。

设计支持 *TI 参考设计支持* 可帮助您快速查找有帮助的 E2E 论坛、设计支持工具以及技术支持的联系信息。

12.5 商标

E2E is a trademark of Texas Instruments.
All other trademarks are the property of their respective owners.

12.6 静电放电警告



这些装置包含有限的内置 ESD 保护。存储或装卸时，应将导线一起截短或将装置放置于导电泡棉中，以防止 MOS 门极遭受静电损伤。

12.7 术语表

SLYZ022 — *TI 术语表*。

这份术语表列出并解释术语、缩写和定义。

13 机械、封装和可订购信息

以下页面包含机械、封装和可订购信息。这些信息是指定器件的最新可用数据。数据如有变更，恕不另行通知，且不会对此文档进行修订。如需获取此数据表的浏览器版本，请参阅左侧的导航栏。

PACKAGING INFORMATION

Orderable Device	Status (1)	Package Type	Package Drawing	Pins	Package Qty	Eco Plan (2)	Lead finish/ Ball material (6)	MSL Peak Temp (3)	Op Temp (°C)	Device Marking (4/5)	Samples
TS3A5018D	LIFEBUY	SOIC	D	16	40	RoHS & Green	NIPDAU	Level-1-260C-UNLIM	-40 to 85	TS3A5018	
TS3A5018DBQR	ACTIVE	SSOP	DBQ	16	2500	RoHS & Green	NIPDAU	Level-2-260C-1 YEAR	-40 to 85	YA018	Samples
TS3A5018DBQRG4	LIFEBUY	SSOP	DBQ	16	2500	RoHS & Green	NIPDAU	Level-2-260C-1 YEAR	-40 to 85	YA018	
TS3A5018DE4	LIFEBUY	SOIC	D	16	40	RoHS & Green	NIPDAU	Level-1-260C-UNLIM	-40 to 85	TS3A5018	
TS3A5018DGVR	ACTIVE	TVSOP	DGV	16	2000	RoHS & Green	NIPDAU	Level-1-260C-UNLIM	-40 to 85	YA018	Samples
TS3A5018DR	ACTIVE	SOIC	D	16	2500	RoHS & Green	NIPDAU	Level-1-260C-UNLIM	-40 to 85	TS3A5018	Samples
TS3A5018PW	LIFEBUY	TSSOP	PW	16	90	RoHS & Green	NIPDAU	Level-1-260C-UNLIM	-40 to 85	YA018	
TS3A5018PWG4	LIFEBUY	TSSOP	PW	16	90	RoHS & Green	NIPDAU	Level-1-260C-UNLIM	-40 to 85	YA018	
TS3A5018PWR	ACTIVE	TSSOP	PW	16	2000	RoHS & Green	NIPDAU	Level-1-260C-UNLIM	-40 to 85	YA018	Samples
TS3A5018PWRE4	LIFEBUY	TSSOP	PW	16	2000	RoHS & Green	NIPDAU	Level-1-260C-UNLIM	-40 to 85	YA018	
TS3A5018RGYR	ACTIVE	VQFN	RGY	16	3000	RoHS & Green	NIPDAU	Level-2-260C-1 YEAR	-40 to 85	YA018	Samples
TS3A5018RSVR	ACTIVE	UQFN	RSV	16	3000	RoHS & Green	NIPDAU NIPDAUAG	Level-1-260C-UNLIM	-40 to 85	ZUN	Samples

(1) The marketing status values are defined as follows:

ACTIVE: Product device recommended for new designs.

LIFEBUY: TI has announced that the device will be discontinued, and a lifetime-buy period is in effect.

NRND: Not recommended for new designs. Device is in production to support existing customers, but TI does not recommend using this part in a new design.

PREVIEW: Device has been announced but is not in production. Samples may or may not be available.

OBSOLETE: TI has discontinued the production of the device.

(2) **RoHS:** TI defines "RoHS" to mean semiconductor products that are compliant with the current EU RoHS requirements for all 10 RoHS substances, including the requirement that RoHS substance do not exceed 0.1% by weight in homogeneous materials. Where designed to be soldered at high temperatures, "RoHS" products are suitable for use in specified lead-free processes. TI may reference these types of products as "Pb-Free".

RoHS Exempt: TI defines "RoHS Exempt" to mean products that contain lead but are compliant with EU RoHS pursuant to a specific EU RoHS exemption.

Green: TI defines "Green" to mean the content of Chlorine (Cl) and Bromine (Br) based flame retardants meet JS709B low halogen requirements of <=1000ppm threshold. Antimony trioxide based flame retardants must also meet the <=1000ppm threshold requirement.

(3) MSL, Peak Temp. - The Moisture Sensitivity Level rating according to the JEDEC industry standard classifications, and peak solder temperature.

(4) There may be additional marking, which relates to the logo, the lot trace code information, or the environmental category on the device.

⁽⁵⁾ Multiple Device Markings will be inside parentheses. Only one Device Marking contained in parentheses and separated by a "~" will appear on a device. If a line is indented then it is a continuation of the previous line and the two combined represent the entire Device Marking for that device.

⁽⁶⁾ Lead finish/Ball material - Orderable Devices may have multiple material finish options. Finish options are separated by a vertical ruled line. Lead finish/Ball material values may wrap to two lines if the finish value exceeds the maximum column width.

Important Information and Disclaimer: The information provided on this page represents TI's knowledge and belief as of the date that it is provided. TI bases its knowledge and belief on information provided by third parties, and makes no representation or warranty as to the accuracy of such information. Efforts are underway to better integrate information from third parties. TI has taken and continues to take reasonable steps to provide representative and accurate information but may not have conducted destructive testing or chemical analysis on incoming materials and chemicals. TI and TI suppliers consider certain information to be proprietary, and thus CAS numbers and other limited information may not be available for release.

In no event shall TI's liability arising out of such information exceed the total purchase price of the TI part(s) at issue in this document sold by TI to Customer on an annual basis.

TAPE AND REEL INFORMATION

QUADRANT ASSIGNMENTS FOR PIN 1 ORIENTATION IN TAPE

*All dimensions are nominal

Device	Package Type	Package Drawing	Pins	SPQ	Reel Diameter (mm)	Reel Width W1 (mm)	A0 (mm)	B0 (mm)	K0 (mm)	P1 (mm)	W (mm)	Pin1 Quadrant
TS3A5018DBQR	SSOP	DBQ	16	2500	330.0	12.5	6.4	5.2	2.1	8.0	12.0	Q1
TS3A5018DGVR	TVSOP	DGV	16	2000	330.0	12.4	6.8	4.0	1.6	8.0	12.0	Q1
TS3A5018DR	SOIC	D	16	2500	330.0	16.4	6.5	10.3	2.1	8.0	16.0	Q1
TS3A5018PWR	TSSOP	PW	16	2000	330.0	12.4	6.9	5.6	1.6	8.0	12.0	Q1
TS3A5018RGYR	VQFN	RGY	16	3000	330.0	12.4	3.8	4.3	1.5	8.0	12.0	Q1
TS3A5018RSVR	UQFN	RSV	16	3000	180.0	12.4	2.1	2.9	0.75	4.0	12.0	Q1
TS3A5018RSVR	UQFN	RSV	16	3000	180.0	13.2	2.1	2.9	0.75	4.0	12.0	Q1
TS3A5018RSVR	UQFN	RSV	16	3000	177.8	12.4	2.0	2.8	0.7	4.0	12.0	Q1

TAPE AND REEL BOX DIMENSIONS



*All dimensions are nominal

Device	Package Type	Package Drawing	Pins	SPQ	Length (mm)	Width (mm)	Height (mm)
TS3A5018DBQR	SSOP	DBQ	16	2500	353.0	353.0	32.0
TS3A5018DGVR	TVSOP	DGV	16	2000	356.0	356.0	35.0
TS3A5018DR	SOIC	D	16	2500	353.0	353.0	32.0
TS3A5018PWR	TSSOP	PW	16	2000	356.0	356.0	35.0
TS3A5018RGYR	VQFN	RGY	16	3000	356.0	356.0	35.0
TS3A5018RSVR	UQFN	RSV	16	3000	200.0	183.0	25.0
TS3A5018RSVR	UQFN	RSV	16	3000	184.0	184.0	19.0
TS3A5018RSVR	UQFN	RSV	16	3000	202.0	201.0	28.0

TUBE

*All dimensions are nominal

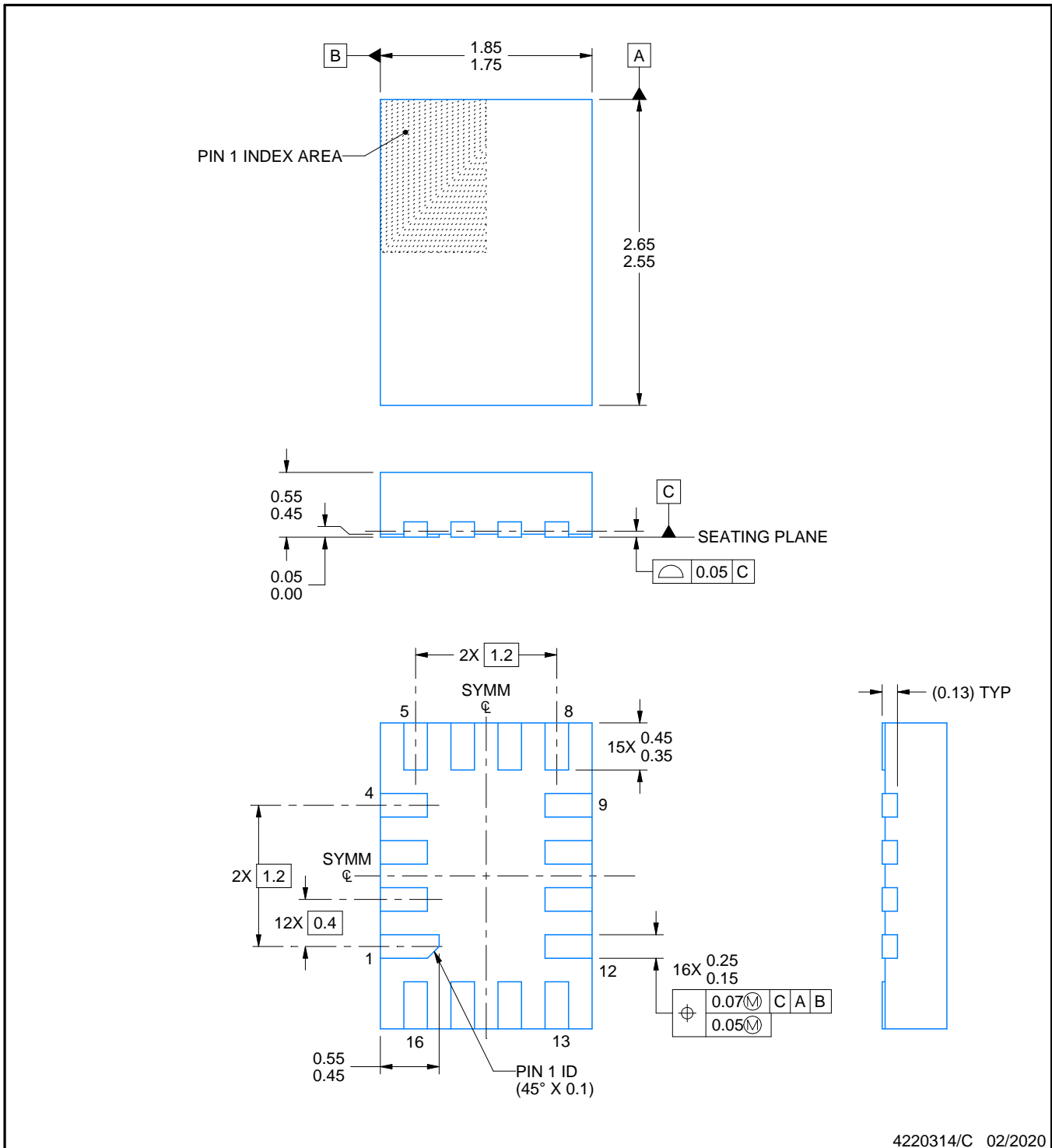
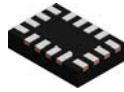
Device	Package Name	Package Type	Pins	SPQ	L (mm)	W (mm)	T (μm)	B (mm)
TS3A5018D	D	SOIC	16	40	507	8	3940	4.32
TS3A5018DE4	D	SOIC	16	40	507	8	3940	4.32
TS3A5018PW	PW	TSSOP	16	90	530	10.2	3600	3.5
TS3A5018PWG4	PW	TSSOP	16	90	530	10.2	3600	3.5



4220314/C 02/2020

NOTES:

1. All linear dimensions are in millimeters. Any dimensions in parenthesis are for reference only. Dimensioning and tolerancing per ASME Y14.5M.
2. This drawing is subject to change without notice.

EXAMPLE BOARD LAYOUT

RSV0016A

UQFN - 0.55 mm max height

ULTRA THIN QUAD FLATPACK - NO LEAD

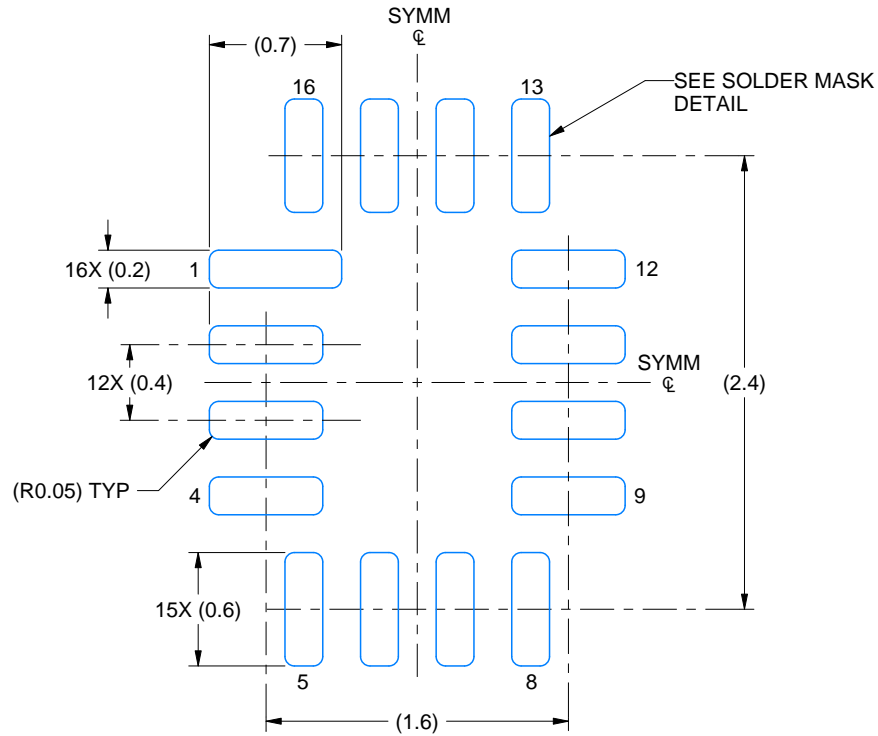

LAND PATTERN EXAMPLE
EXPOSED METAL SHOWN
SCALE: 25X

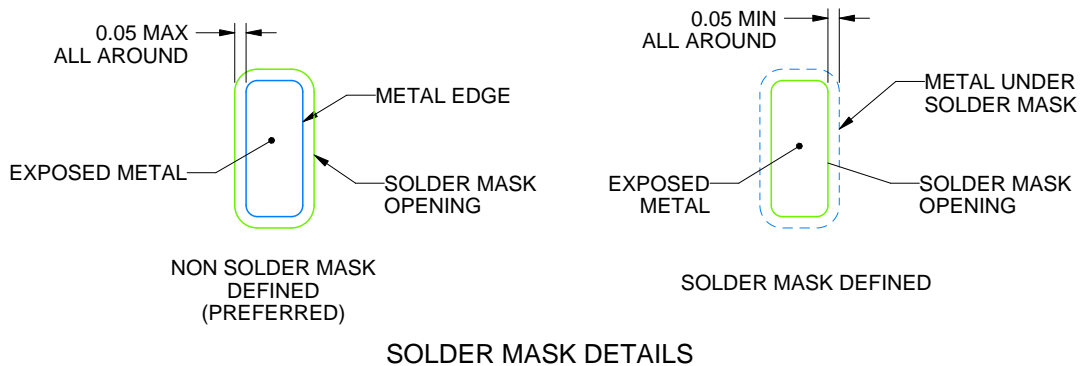

4220314/C 02/2020

NOTES: (continued)

3. For more information, see Texas Instruments literature number SLUA271 (www.ti.com/lit/slua271).

EXAMPLE STENCIL DESIGN

RSV0016A

UQFN - 0.55 mm max height

ULTRA THIN QUAD FLATPACK - NO LEAD

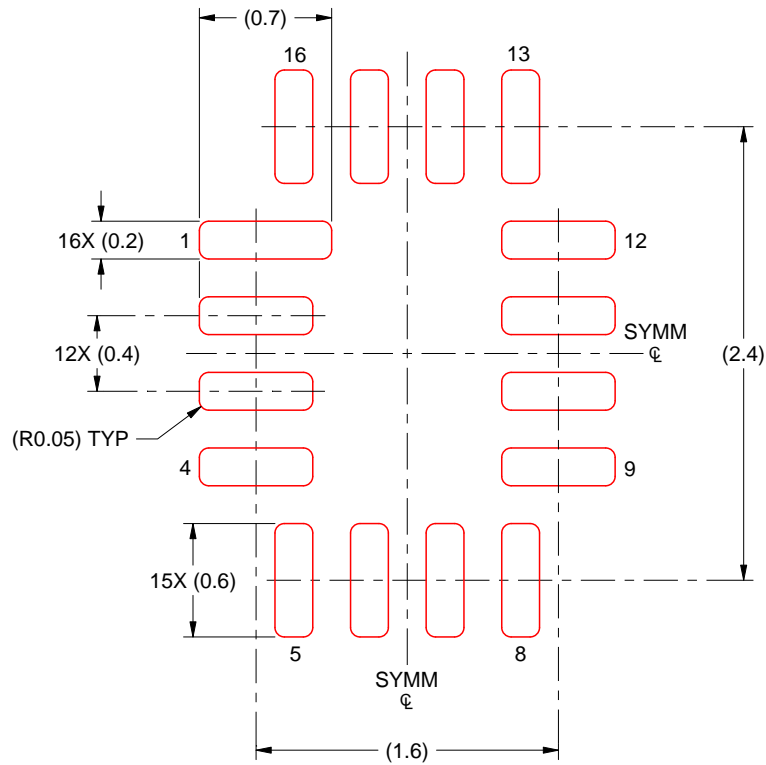

SOLDER PASTE EXAMPLE
BASED ON 0.125 MM THICK STENCIL
SCALE: 25X

4220314/C 02/2020

NOTES: (continued)

4. Laser cutting apertures with trapezoidal walls and rounded corners may offer better paste release. IPC-7525 may have alternate design recommendations.

DGV (R-PDSO-G**)

PLASTIC SMALL-OUTLINE

24 PINS SHOWN



- NOTES: A. All linear dimensions are in millimeters.
 B. This drawing is subject to change without notice.
 C. Body dimensions do not include mold flash or protrusion, not to exceed 0,15 per side.
 D. Falls within JEDEC: 24/48 Pins – MO-153
 14/16/20/56 Pins – MO-194

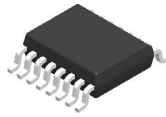

DBQ0016A

PACKAGE OUTLINE

SSOP - 1.75 mm max height

SHRINK SMALL-OUTLINE PACKAGE

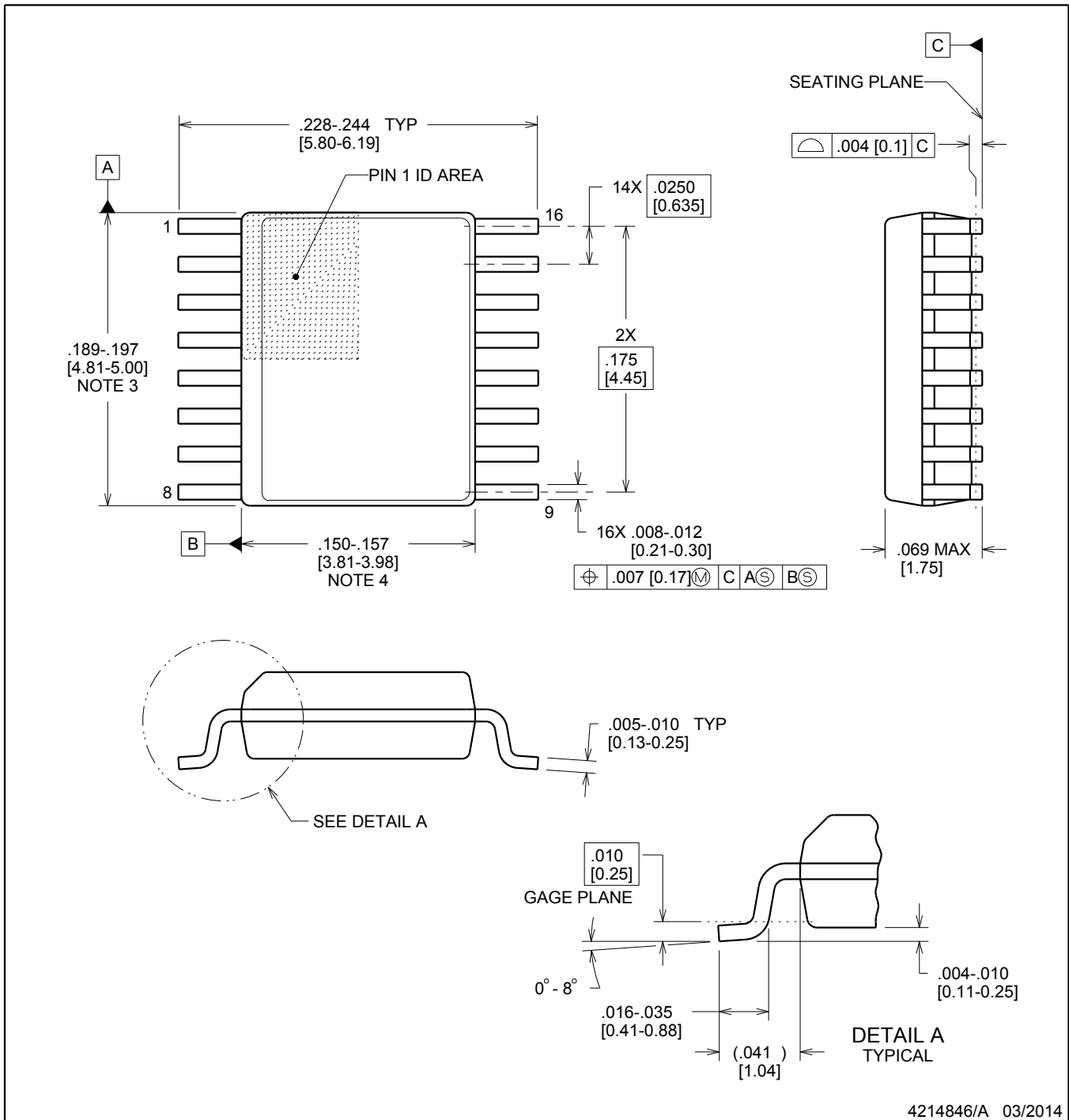

4214846/A 03/2014

NOTES:

- Linear dimensions are in inches [millimeters]. Dimensions in parenthesis are for reference only. Controlling dimensions are in inches. Dimensioning and tolerancing per ASME Y14.5M.
- This drawing is subject to change without notice.
- This dimension does not include mold flash, protrusions, or gate burrs. Mold flash, protrusions, or gate burrs shall not exceed .006 inch, per side.
- This dimension does not include interlead flash.
- Reference JEDEC registration MO-137, variation AB.

EXAMPLE BOARD LAYOUT

DBQ0016A

SSOP - 1.75 mm max height

SHRINK SMALL-OUTLINE PACKAGE

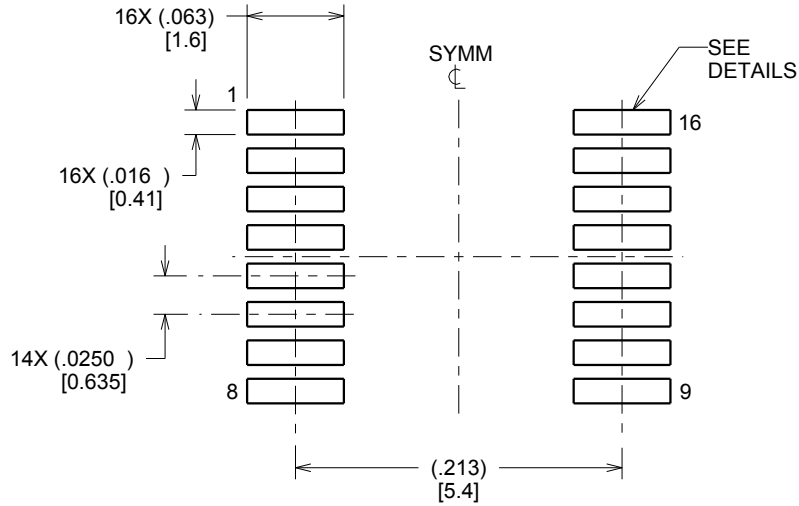

LAND PATTERN EXAMPLE
SCALE:8X

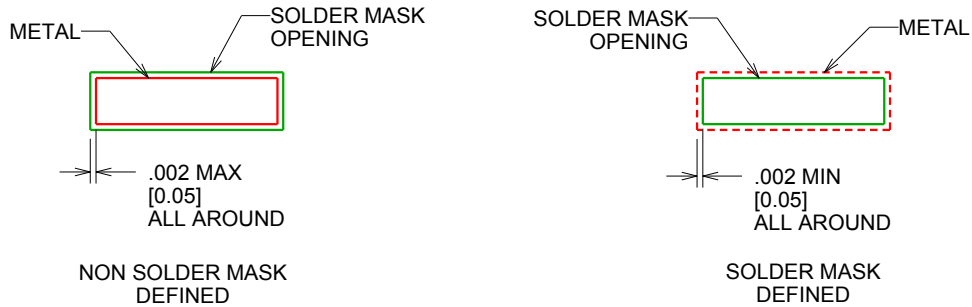

SOLDER MASK DETAILS

4214846/A 03/2014

NOTES: (continued)

- 6. Publication IPC-7351 may have alternate designs.
- 7. Solder mask tolerances between and around signal pads can vary based on board fabrication site.

EXAMPLE STENCIL DESIGN

DBQ0016A

SSOP - 1.75 mm max height

SHRINK SMALL-OUTLINE PACKAGE

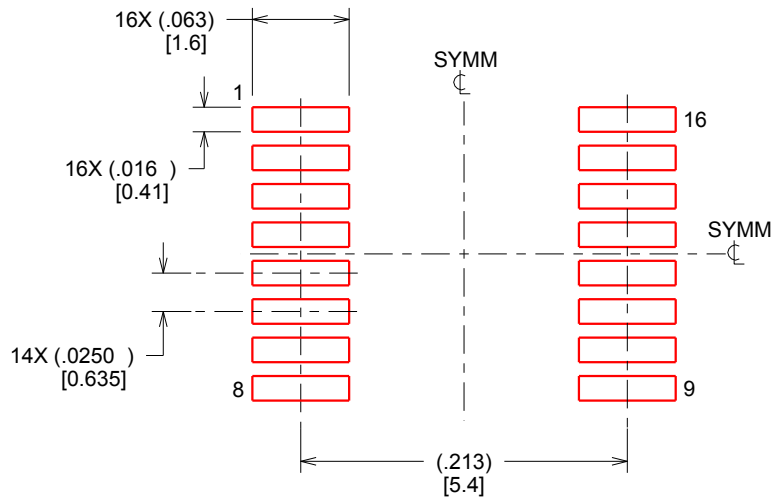

SOLDER PASTE EXAMPLE
BASED ON .005 INCH [0.127 MM] THICK STENCIL
SCALE:8X

4214846/A 03/2014

NOTES: (continued)

8. Laser cutting apertures with trapezoidal walls and rounded corners may offer better paste release. IPC-7525 may have alternate design recommendations.
9. Board assembly site may have different recommendations for stencil design.

RGY (R-PVQFN-N16)

PLASTIC QUAD FLATPACK NO-LEAD

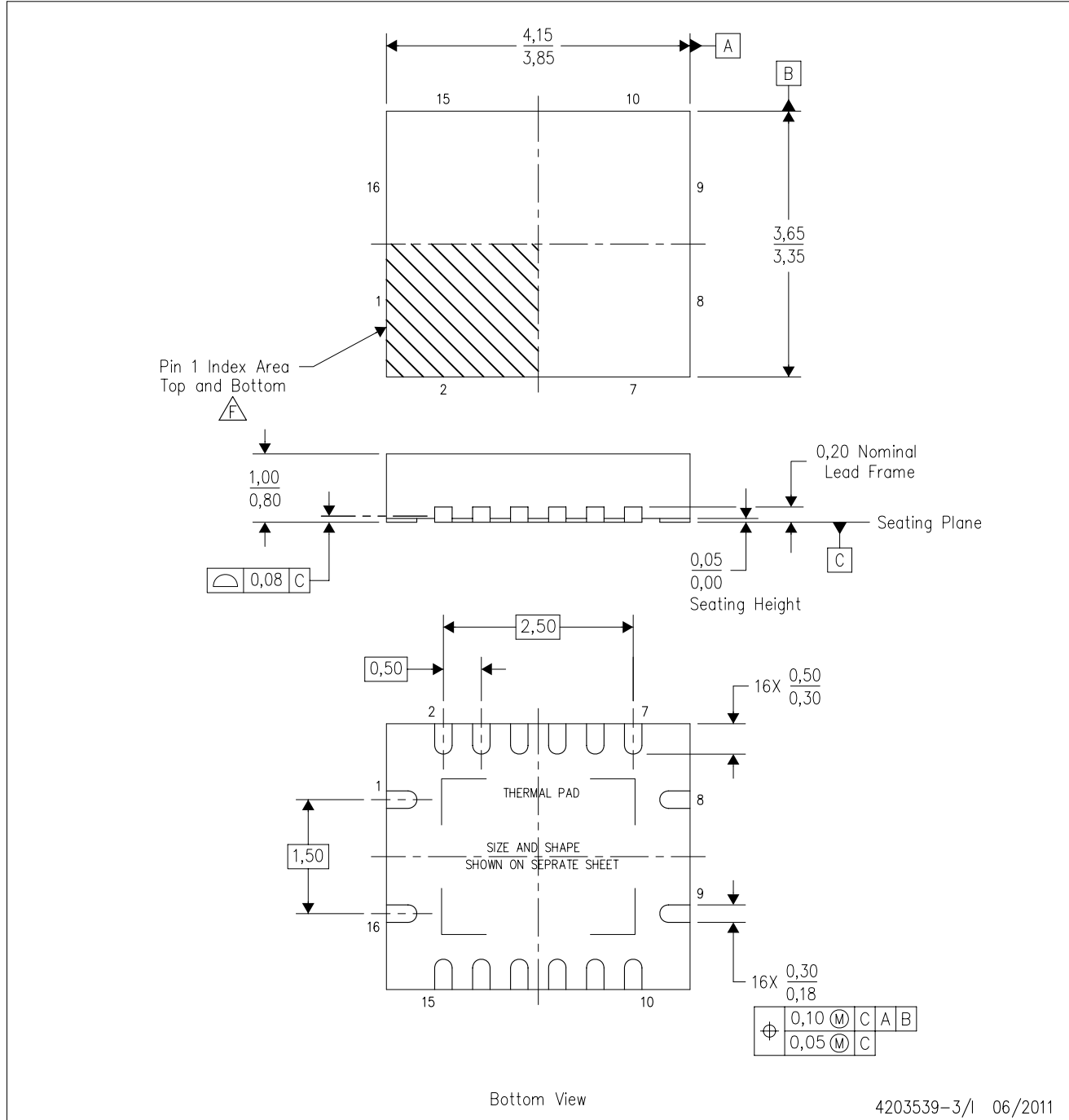

- NOTES:
- A. All linear dimensions are in millimeters. Dimensioning and tolerancing per ASME Y14.5M-1994.
 - B. This drawing is subject to change without notice.
 - C. QFN (Quad Flatpack No-Lead) package configuration.
 - D. The package thermal pad must be soldered to the board for thermal and mechanical performance.
 - E. See the additional figure in the Product Data Sheet for details regarding the exposed thermal pad features and dimensions.
 - F. Pin 1 identifiers are located on both top and bottom of the package and within the zone indicated. The Pin 1 identifiers are either a molded, marked, or metal feature.
 - G. Package complies to JEDEC MO-241 variation BA.

RGY (R-PVQFN-N16)

PLASTIC QUAD FLATPACK NO-LEAD

THERMAL INFORMATION

This package incorporates an exposed thermal pad that is designed to be attached directly to an external heatsink. The thermal pad must be soldered directly to the printed circuit board (PCB). After soldering, the PCB can be used as a heatsink. In addition, through the use of thermal vias, the thermal pad can be attached directly to the appropriate copper plane shown in the electrical schematic for the device, or alternatively, can be attached to a special heatsink structure designed into the PCB. This design optimizes the heat transfer from the integrated circuit (IC).

For information on the Quad Flatpack No-Lead (QFN) package and its advantages, refer to Application Report, QFN/SON PCB Attachment, Texas Instruments Literature No. SLUA271. This document is available at www.ti.com.

The exposed thermal pad dimensions for this package are shown in the following illustration.

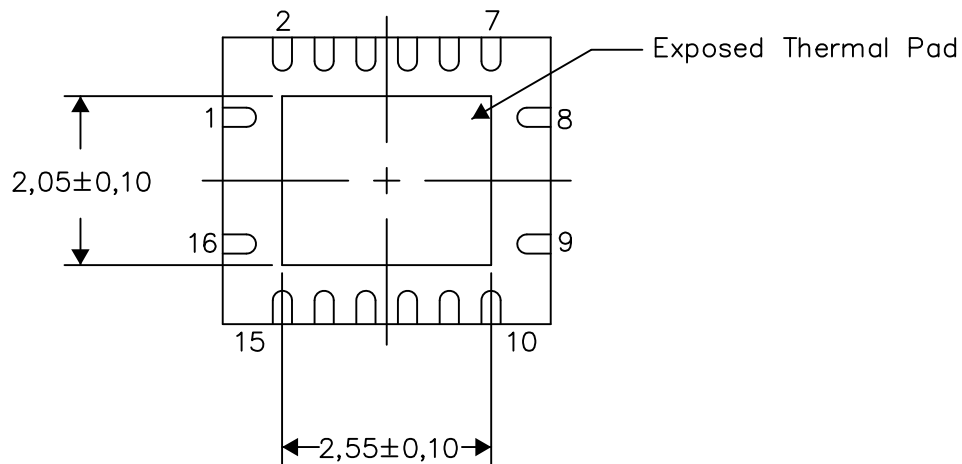

Bottom View

Exposed Thermal Pad Dimensions

4206353-3/P 03/14

NOTE: All linear dimensions are in millimeters

RGY (R-PVQFN-N16)

PLASTIC QUAD FLATPACK NO-LEAD

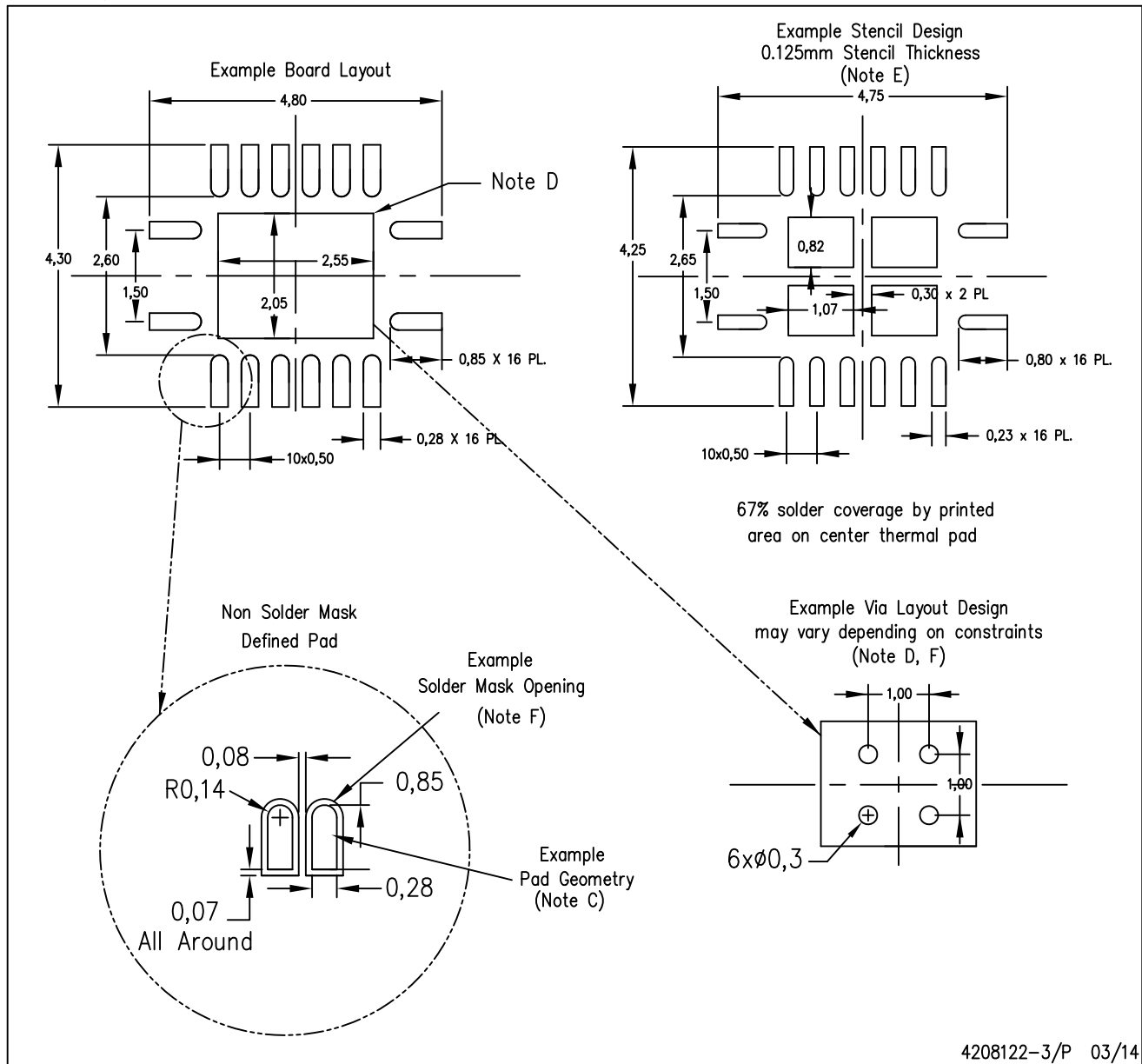

4208122-3/P 03/14



- NOTES:
- A. All linear dimensions are in millimeters.
 - B. This drawing is subject to change without notice.
 - C. Publication IPC-7351 is recommended for alternate designs.
 - D. This package is designed to be soldered to a thermal pad on the board. Refer to Application Note, Quad Flat-Pack QFN/SON PCB Attachment, Texas Instruments Literature No. SLUA271, and also the Product Data Sheets for specific thermal information, via requirements, and recommended board layout. These documents are available at www.ti.com <<http://www.ti.com>>.
 - E. Laser cutting apertures with trapezoidal walls and also rounding corners will offer better paste release. Customers should contact their board assembly site for stencil design recommendations. Refer to IPC 7525 for stencil design considerations.
 - F. Customers should contact their board fabrication site for minimum solder mask web tolerances between signal pads.

D (R-PDSO-G16)

PLASTIC SMALL OUTLINE



4040047-6/M 06/11

- NOTES:
- A. All linear dimensions are in inches (millimeters).
 - B. This drawing is subject to change without notice.
 -  C. Body length does not include mold flash, protrusions, or gate burrs. Mold flash, protrusions, or gate burrs shall not exceed 0.006 (0,15) each side.
 -  D. Body width does not include interlead flash. Interlead flash shall not exceed 0.017 (0,43) each side.
 - E. Reference JEDEC MS-012 variation AC.



4220204/A 02/2017

NOTES:

1. All linear dimensions are in millimeters. Any dimensions in parenthesis are for reference only. Dimensioning and tolerancing per ASME Y14.5M.
2. This drawing is subject to change without notice.
3. This dimension does not include mold flash, protrusions, or gate burrs. Mold flash, protrusions, or gate burrs shall not exceed 0.15 mm per side.
4. This dimension does not include interlead flash. Interlead flash shall not exceed 0.25 mm per side.
5. Reference JEDEC registration MO-153.

EXAMPLE BOARD LAYOUT

PW0016A

TSSOP - 1.2 mm max height

SMALL OUTLINE PACKAGE



LAND PATTERN EXAMPLE
EXPOSED METAL SHOWN
SCALE: 10X



SOLDER MASK DETAILS

4220204/A 02/2017

NOTES: (continued)

- 6. Publication IPC-7351 may have alternate designs.
- 7. Solder mask tolerances between and around signal pads can vary based on board fabrication site.

EXAMPLE STENCIL DESIGN

PW0016A

TSSOP - 1.2 mm max height

SMALL OUTLINE PACKAGE



SOLDER PASTE EXAMPLE
BASED ON 0.125 mm THICK STENCIL
SCALE: 10X

4220204/A 02/2017

NOTES: (continued)

8. Laser cutting apertures with trapezoidal walls and rounded corners may offer better paste release. IPC-7525 may have alternate design recommendations.
9. Board assembly site may have different recommendations for stencil design.

重要声明和免责声明

TI“按原样”提供技术和可靠性数据（包括数据表）、设计资源（包括参考设计）、应用或其他设计建议、网络工具、安全信息和其他资源，不保证没有瑕疵且不做任何明示或暗示的担保，包括但不限于对适销性、某特定用途方面的适用性或不侵犯任何第三方知识产权的暗示担保。

这些资源可供使用 TI 产品进行设计的熟练开发人员使用。您将自行承担以下全部责任：(1) 针对您的应用选择合适的 TI 产品，(2) 设计、验证并测试您的应用，(3) 确保您的应用满足相应标准以及任何其他功能安全、信息安全、监管或其他要求。

这些资源如有变更，恕不另行通知。TI 授权您仅可将这些资源用于研发本资源所述的 TI 产品的应用。严禁对这些资源进行其他复制或展示。您无权使用任何其他 TI 知识产权或任何第三方知识产权。您应全额赔偿因在这些资源的使用中对 TI 及其代表造成的任何索赔、损害、成本、损失和债务，TI 对此概不负责。

TI 提供的产品受 [TI 的销售条款](#) 或 [ti.com](#) 上其他适用条款/TI 产品随附的其他适用条款的约束。TI 提供这些资源并不会扩展或以其他方式更改 TI 针对 TI 产品发布的适用的担保或担保免责声明。

TI 反对并拒绝您可能提出的任何其他或不同的条款。

邮寄地址：Texas Instruments, Post Office Box 655303, Dallas, Texas 75265
Copyright © 2024，德州仪器 (TI) 公司