

ULQ200xA-Q1 High-Voltage High-Current Darlington Transistor Arrays

1 Features

- Qualified for automotive applications
- ESD protection exceeds 200V using machine model (C = 200pF, R = 0)
- 500mA-rated collector current (single output)
- High-voltage outputs: 50V
- Output clamp diodes
- Inputs compatible with various types of logic
- Relay-driver applications

2 Applications

- Relay drivers
- Stepper and DC brushed motor drivers
- Lamp drivers
- Display drivers (LED and gas discharge)
- Line drivers
- Logic buffers

3 Description

The ULQ200xA-Q1 devices are high-voltage high-current Darlington transistor arrays. Each consists of seven npn Darlington pairs that feature high-voltage outputs with common-cathode clamp diodes for switching inductive loads. The collector-current rating of a single Darlington pair is 500mA. The Darlington pairs can be paralleled for higher current capability.

The ULQ2003A-Q1 has a 2.7kΩ series base resistor for each Darlington pair, for operation directly with TTL or 5V CMOS devices. The ULQ2004A-Q1 has a 10.5kΩ series base resistor to allow operation directly from CMOS devices that use supply voltages of 6V to 15V. The required input current of the ULQ2004A-Q1 is below that of the ULQ2003A-Q1.

Package Information

PART NUMBER	PACKAGE ⁽¹⁾	PACKAGE SIZE ⁽²⁾
ULQ2003A-Q1	SOIC (16)	9.90mm × 3.90mm
	TSSOP (16)	5.00mm × 4.40mm
	SOT (16)	4.20mm × 2.00mm
ULQ2004A-Q1	SOIC (16)	9.90mm × 3.90mm

(1) For all available packages, see the orderable addendum at the end of the data sheet.

(2) The package size (length × width) is a nominal value and includes pins, where applicable.

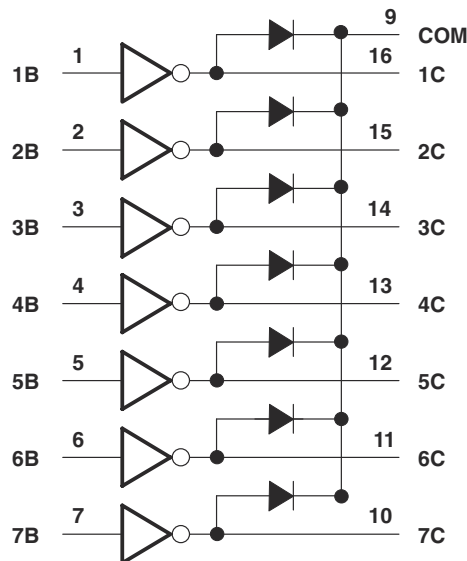

Simplified Block Diagram



Table of Contents

1 Features	1	7.2 Functional Block Diagram.....	11
2 Applications	1	7.3 Feature Description.....	12
3 Description	1	7.4 Device Functional Modes.....	12
4 Pin Configuration and Functions	2	8 Application and Implementation	13
5 Specifications	4	8.1 Application Information.....	13
5.1 Absolute Maximum Ratings.....	4	8.2 Typical Application.....	13
5.2 ESD Ratings.....	4	8.3 System Examples.....	16
5.3 Recommended Operating Conditions.....	4	8.4 Power Supply Recommendations.....	16
5.4 Thermal Information.....	4	8.5 Layout.....	16
5.5 Electrical Characteristics, ULQ2003AT and ULQ2003AQ.....	5	9 Device and Documentation Support	18
5.6 Electrical Characteristics, ULQ2004AT.....	5	9.1 Related Links.....	18
5.7 Switching Characteristics, ULQ2003A and ULQ2004A.....	6	9.2 Support Resources.....	18
5.8 Dissipation Ratings.....	6	9.3 Trademarks.....	18
5.9 Typical Characteristics.....	6	9.4 Electrostatic Discharge Caution.....	18
6 Parameter Measurement Information	7	9.5 Glossary.....	18
7 Detailed Description	11	10 Revision History	18
7.1 Overview.....	11	11 Mechanical, Packaging, and Orderable Information	18

4 Pin Configuration and Functions

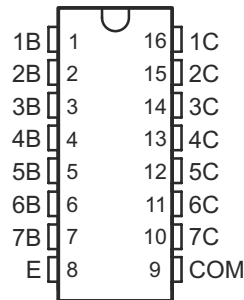

Figure 4-1. D or PW Package, 16-Pin SOIC or TSSOP (Top View)

Table 4-1. Pin Functions

PIN		I/O	DESCRIPTION
NO.	NAME		
1	1B	I	Channel 1 through 7 Darlington base input.
2	2B		
3	3B		
4	4B		
5	5B		
6	6B		
7	7B		
8	E	—	Common emitter shared by all channels (typically tied to ground).
9	COM	—	Common cathode node for flyback diodes (required for inductive loads).

Table 4-1. Pin Functions (continued)

PIN		I/O	DESCRIPTION
NO.	NAME		
10	7C	O	Channel 1 through 7 Darlington collector output.
11	6C		
12	5C		
13	4C		
14	3C		
15	2C		
16	1C		

5 Specifications

5.1 Absolute Maximum Ratings

at 25°C free-air temperature (unless otherwise noted)⁽¹⁾

		MIN	MAX	UNIT	
V _{CE}	Collector-emitter voltage		50	V	
	Clamp diode reverse voltage ⁽²⁾		50	V	
V _I	Input voltage ⁽²⁾		30	V	
	Peak collector current	See Figure 8-2	500	mA	
I _{OK}	Output clamp current		500	mA	
	Total emitter-terminal current		-2.5	A	
P _D	Continuous total power dissipation		See Section 5.8		
T _A	Operating free-air temperature	ULQ200xAT	-40	105	°C
		ULQ200xAQ	-40	125	
T _J	Junction temperature		150	°C	
T _{stg}	Storage temperature	-65	150	°C	

- (1) Stresses beyond those listed under Absolute Maximum Ratings may cause permanent damage to the device. These are stress ratings only, and functional operation of the device at these or any other conditions beyond those indicated under [Section 5.3](#) is not implied. Exposure to absolute-maximum-rated conditions for extended periods may affect device reliability.
- (2) All voltage values are with respect to the emitter/substrate terminal E, unless otherwise noted.

5.2 ESD Ratings

		VALUE	UNIT	
V _(ESD)	Electrostatic discharge	Human-body model (HBM), per AEC Q100-002 ⁽¹⁾	±2000	V
		Charged-device model (CDM), per AEC Q100-011	±500	

- (1) AEC Q100-002 indicates HBM stressing is done in accordance with the ANSI/ESDA/JEDEC JS-001 specification.

5.3 Recommended Operating Conditions

over operating free-air temperature range (unless otherwise noted)

		MIN	MAX	UNIT
V _{CE}	Collector-emitter voltage	0	50	V
T _J	Junction temperature	-40	125	°C

5.4 Thermal Information

THERMAL METRIC ⁽¹⁾		ULQ2003A-Q1, ULQ2004A-Q1	ULQ2003A-Q1		UNIT
		D (SOIC)	PW (TSSOP)	DYY (SOT)	
		16 PINS	16 PINS	16 PINS	
R _{θJA}	Junction-to-ambient thermal resistance	87.9	112.9	119.4	°C/W
R _{θJC(top)}	Junction-to-case (top) thermal resistance	49.4	49.2	56.9	°C/W
R _{θJB}	Junction-to-board thermal resistance	49.1	58.1	52.3	°C/W
Ψ _{JT}	Junction-to-top characterization parameter	11.9	9.1	2.8	°C/W
Ψ _{JB}	Junction-to-board characterization parameter	48.6	57.6	51.9	°C/W

- (1) For more information about traditional and new thermal metrics, see the *Semiconductor and IC Package Thermal Metrics* application report, [SPRA953](#).

5.5 Electrical Characteristics, ULQ2003AT and ULQ2003AQ

over recommended operating conditions (unless otherwise noted)

PARAMETER		TEST CONDITIONS		MIN	TYP	MAX	UNIT
$V_{I(on)}$	On-state input voltage	$V_{CE} = 2\text{ V}$, see Figure 6-8	$I_C = 200\text{ mA}$			2.7	V
			$I_C = 250\text{ mA}$			2.9	
			$I_C = 300\text{ mA}$			3	
$V_{CE(sat)}$	Collector-emitter saturation voltage	$I_I = 250\text{ }\mu\text{A}, I_C = 100\text{ mA}$, see Figure 6-7	ULQ2003AT		0.9	1.2	V
			ULQ2003AQ		1	1.3	
			ULQ2003AT		1	1.4	
			ULQ2003AQ		1	1.5	
			ULQ2003AT		1.2	1.7	
I_{CEX}	Collector cutoff current	$V_{CE} = 50\text{ V}$, $I_I = 0$, see Figure 6-1	$T_A = 25^\circ\text{C}$			100	μA
			$T_A = 105^\circ\text{C}$, ULQ2003AT				
V_F	Clamp forward voltage	$I_F = 350\text{ mA}$, see Figure 6-6			1.7	2.2	V
$I_{I(off)}$	Off-state input current	$V_{CE} = 50\text{ V}$, $I_C = 500\text{ }\mu\text{A}$, see Figure 6-3		30	65		μA
I_I	Input current	$V_I = 3.85\text{ V}$, see Figure 6-4			0.93	1.35	mA
I_R	Clamp reverse current	$V_R = 50\text{ V}$, $T_A = 25^\circ\text{C}$, see Figure 6-5				100	μA
C_i	Input capacitance	$V_I = 0$, $f = 1\text{ MHz}$			15	25	pF

5.6 Electrical Characteristics, ULQ2004AT

over recommended operating conditions (unless otherwise noted)

PARAMETER		TEST CONDITIONS		MIN	TYP	MAX	UNIT	
$V_{I(on)}$	On-state input voltage	$V_{CE} = 2\text{ V}$, see Figure 6-8	$I_C = 125\text{ mA}$			5	V	
			$I_C = 200\text{ mA}$			6		
			$I_C = 275\text{ mA}$			7		
			$I_C = 350\text{ mA}$			8		
$V_{CE(sat)}$	Collector-emitter saturation voltage	$I_I = 250\text{ }\mu\text{A}, I_C = 100\text{ mA}$, see Figure 6-7			0.9	1.1	V	
			$I_I = 350\text{ }\mu\text{A}, I_C = 200\text{ mA}$, see Figure 6-7			1		1.3
			$I_I = 500\text{ }\mu\text{A}, I_C = 350\text{ mA}$, see Figure 6-7			1.2		1.6
I_{CEX}	Collector cutoff current	$V_{CE} = 50\text{ V}$, $I_I = 0$, see Figure 6-1	$T_A = 25^\circ\text{C}$			50	μA	
			$T_A = 105^\circ\text{C}$					
			$V_{CE} = 50\text{ V}$, see Figure 6-2	$I_I = 0$				100
			$V_I = 1\text{ V}$					500
V_F	Clamp forward voltage	$I_F = 350\text{ mA}$, see Figure 6-6			1.7	2.1	V	
$I_{I(off)}$	Off-state input current	$V_{CE} = 50\text{ V}$, $I_C = 500\text{ }\mu\text{A}$, see Figure 6-3		50	65		μA	
I_I	Input current	$V_I = 5\text{ V}$, see Figure 6-4			0.35	0.5	mA	
		$V_I = 12\text{ V}$, see Figure 6-4			1	1.45		
I_R	Clamp reverse current	$V_R = 50\text{ V}$, see Figure 6-5	$T_A = 25^\circ\text{C}$			50	μA	
			$T_A = 105^\circ\text{C}$					100
C_i	Input capacitance	$V_I = 0$, $f = 1\text{ MHz}$			15	25	pF	

5.7 Switching Characteristics, ULQ2003A and ULQ2004A

over recommended operating conditions (unless otherwise noted)

PARAMETER		TEST CONDITIONS	MIN	TYP	MAX	UNIT
t_{PLH}	Propagation delay time, low- to high-level output	See Figure 6-9		1	10	μs
t_{PHL}	Propagation delay time, high- to low-level output	See Figure 6-9		1	10	μs
V_{OH}	High-level output voltage after switching	$V_S = 50\text{ V}$, $I_O = 300\text{ mA}$, see Figure 6-10	$V_S - 500$			mV

5.8 Dissipation Ratings

PACKAGE	$T_A = 25^\circ\text{C}$ POWER RATING	DERATING FACTOR ABOVE $T_A = 25^\circ\text{C}$	$T_A = 85^\circ\text{C}$ POWER RATING	$T_A = 105^\circ\text{C}$ POWER RATING	$T_A = 125^\circ\text{C}$ POWER RATING
D	950 mW	7.6 mW/ $^\circ\text{C}$	494 mW	342 mW	190 mW

5.9 Typical Characteristics

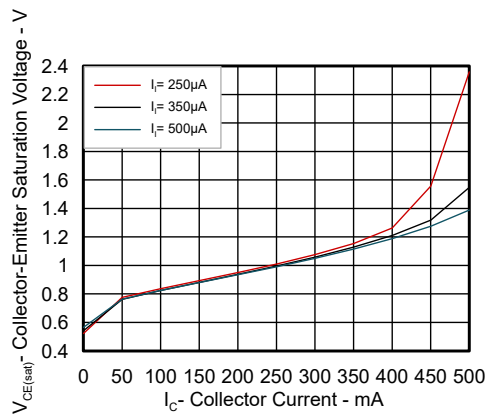

Figure 5-1. Collector-Emitter Saturation Voltage vs Collector Current (One Darlington)

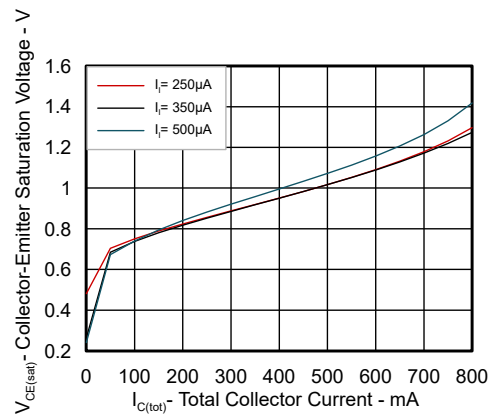

Figure 5-2. Collector-Emitter Saturation Voltage vs Collector Current (Two Darlings in Parallel)

6 Parameter Measurement Information

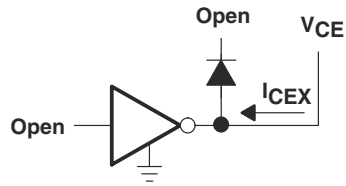

Figure 6-1. I_{CEX} Test Circuit

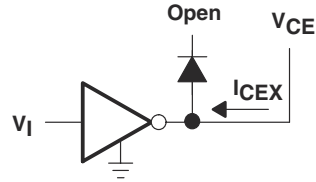

Figure 6-2. I_{CEX} Test Circuit

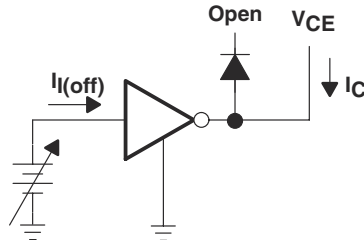

Figure 6-3. $I_{I(off)}$ Test Circuit

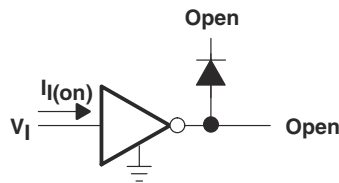

Figure 6-4. I_I Test Circuit

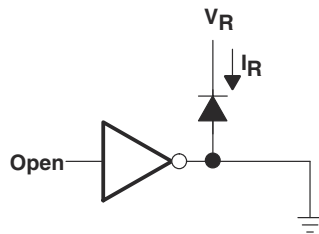

Figure 6-5. I_R Test Circuit

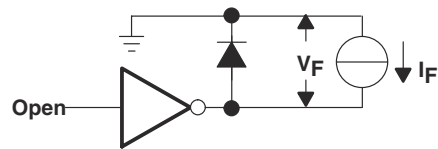
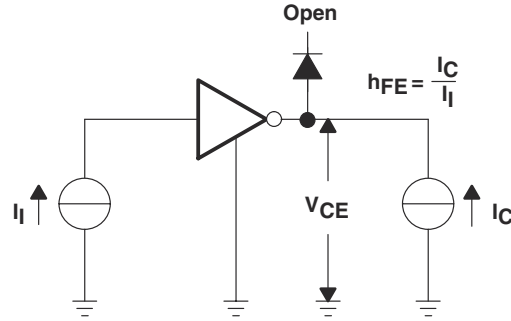

Figure 6-6. V_F Test Circuit



A. I_i is fixed for measuring $V_{CE(sat)}$, variable for measuring h_{FE} .

Figure 6-7. h_{FE} , $V_{CE(sat)}$ Test Circuit

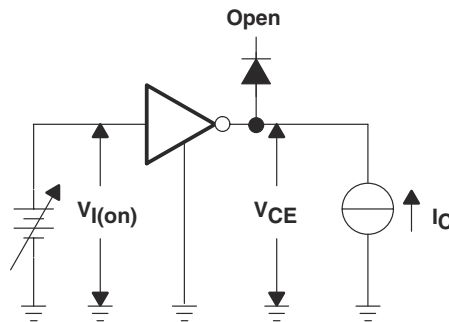

Figure 6-8. $V_{I(on)}$ Test Circuit

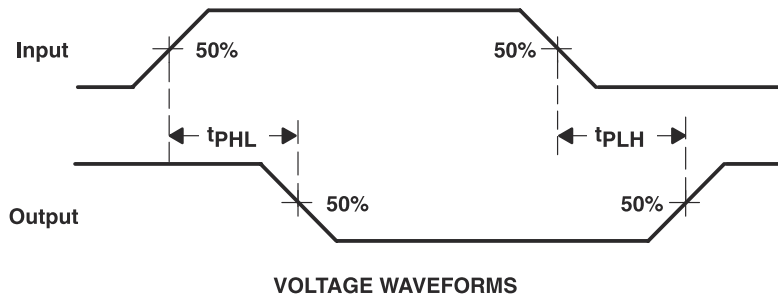
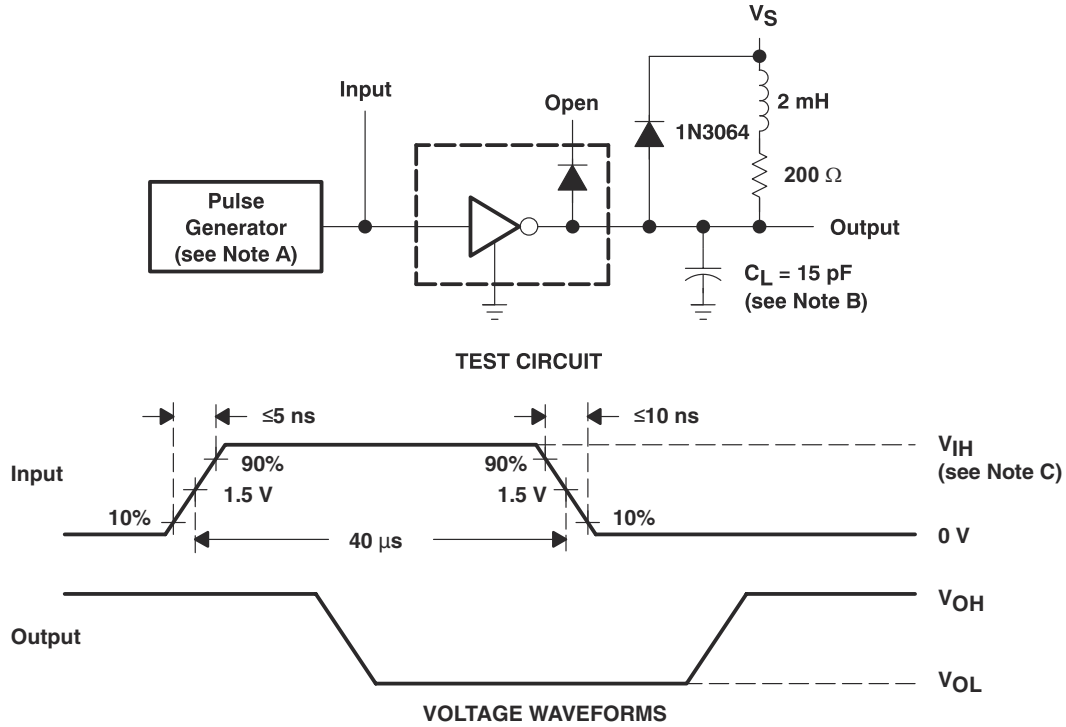

Figure 6-9. Propagation Delay-Time Waveforms



- A. The pulse generator has the following characteristics: PRR = 12.5 kHz, $Z_O = 50 \Omega$.
- B. C_L includes probe and jig capacitance.
- C. For testing the ULQ2003A, $V_{IH} = 3 \text{ V}$; for the ULQ2004A, $V_{IH} = 8 \text{ V}$.

Figure 6-10. Latch-Up Test Circuit and Voltage Waveforms

7 Detailed Description

7.1 Overview

This standard device has proven ubiquity and versatility across a wide range of applications. This is due to integration of 7 Darlington transistors of the device that are capable of sinking up to 500 mA and wide GPIO range capability.

The ULQ200xA-Q1 devices comprise seven high-voltage, high-current NPN Darlington transistor pairs. All units feature a common emitter and open collector outputs. To maximize their effectiveness, these units contain suppression diodes for inductive loads. The ULN200xA-Q1 devices have a series base resistor to each Darlington pair, thus allowing operation directly with TTL or CMOS operating at supply voltages of 5 V or 3.3 V. The ULQ2003xA-Q1 device offers solutions to a great many interface needs, including solenoids, relays, lamps, small motors, and LEDs. Applications requiring sink currents beyond the capability of a single output may be accommodated by paralleling the outputs.

This device can operate over a wide temperature range (−40°C to 105°C for ULQ200xAT or −40°C to 125°C for ULQ2003AQ).

7.2 Functional Block Diagram

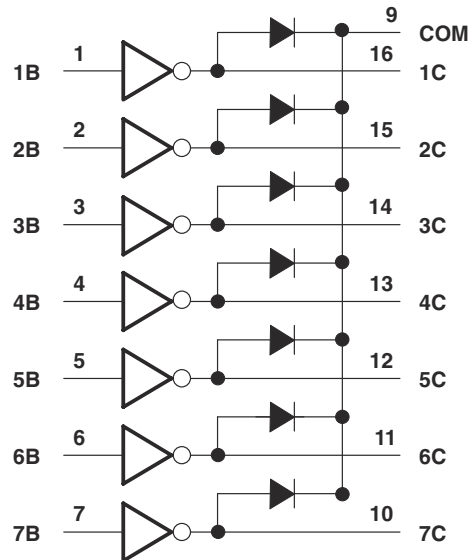
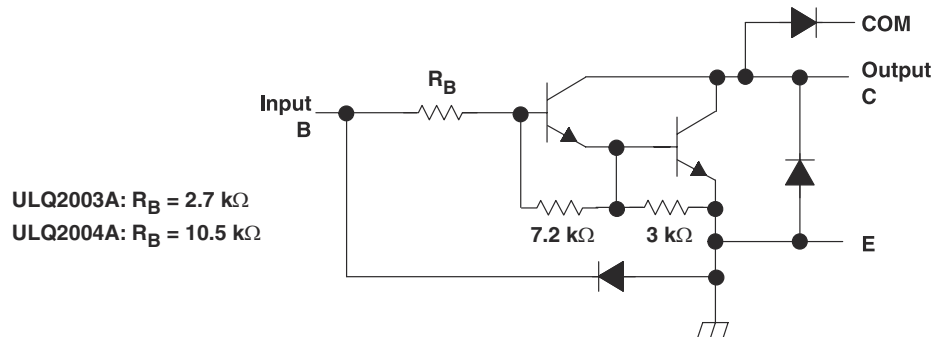

Figure 7-1. Logic Diagram



- A. All resistor values shown are nominal.
- B. The collector-emitter diode is a parasitic structure and should not be used to conduct current. If the collector(s) go below ground an external Schottky diode should be added to clamp negative undershoots.

Figure 7-2. Schematics (Each Darlington Pair)

7.3 Feature Description

Each channel of the ULQ200xA-Q1 devices consist of Darlington connected NPN transistors. This connection creates the effect of a single transistor with a very high-current gain (β^2). This can be as high as 10,000 A/A at certain currents. The very high β allows for high-output current drive with a very low input current, essentially equating to operation with low GPIO voltages.

The GPIO voltage is converted to base current through the 2.7-k Ω or 10.5-k Ω resistor connected between the input and base of the predriver Darlington NPN. The 7.2-k Ω and 3-k Ω resistors connected between the base and emitter of each respective NPN act as pulldowns and suppress the amount of leakage that may occur from the input.

The diodes connected between the output and COM pin is used to suppress the kick-back voltage from an inductive load that is excited when the NPN drivers are turned off (stop sinking) and the stored energy in the coils causes a reverse current to flow into the coil supply through the kick-back diode.

In normal operation the diodes on base and collector pins to emitter will be reversed biased. If these diodes are forward biased, internal parasitic NPN transistors will draw (a nearly equal) current from other (nearby) device pins.

7.4 Device Functional Modes

7.4.1 Inductive Load Drive

When the COM pin is tied to the coil supply voltage, ULQ200xA-Q1 devices are able to drive inductive loads and suppress the kick-back voltage through the internal free-wheeling diodes.

7.4.2 Resistive Load Drive

When driving a resistive load, a pullup resistor is needed in order for the ULQ200xA-Q1 devices to sink current and for there to be a logic high level. The COM pin can be left floating for these applications.

8 Application and Implementation

Note

Information in the following applications sections is not part of the TI component specification, and TI does not warrant its accuracy or completeness. TI's customers are responsible for determining suitability of components for their purposes, as well as validating and testing their design implementation to confirm system functionality.

8.1 Application Information

Typically, the ULQ200xA-Q1 device drives a high-voltage or high-current (or both) peripheral from an MCU or logic device that cannot tolerate these conditions. This design is a common application of ULQ200xA-Q1 device, driving inductive loads. This includes motors, solenoids and relays. [Figure 8-1](#) shows an example of driving multiple inductive loads.

8.2 Typical Application

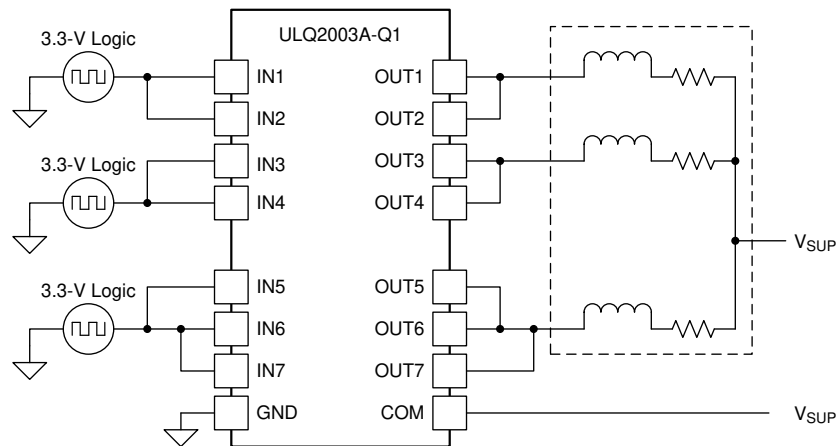

Figure 8-1. ULQ2003A-Q1 Device as Inductive Load Driver

8.2.1 Design Requirements

For this design example, use the parameters listed in [Table 8-1](#) as the input parameters.

Table 8-1. Design Parameters

DESIGN PARAMETER	EXAMPLE VALUE
GPIO voltage	3.3 V or 5 V
Coil supply voltage	12 V to 48 V
Number of channels	7
Output current (R_{COIL})	20 mA to 300 mA per channel
Duty cycle	100%

8.2.2 Detailed Design Procedure

When using ULQ2003A-Q1 device in a coil driving application, determine the following:

- Input voltage range
- Temperature range
- Output and drive current
- Power dissipation

8.2.2.1 Drive Current

The coil voltage (V_{SUP}), coil resistance (R_{COIL}), and low-level output voltage ($V_{CE(SAT)}$ or V_{OL}) determine the coil current.

$$I_{COIL} = (V_{SUP} - V_{CE(SAT)}) / R_{COIL} \quad (1)$$

8.2.2.2 Low-Level Output Voltage

The low-level output voltage (V_{OL}) is the same as $V_{CE(SAT)}$ and can be determined by [Figure 5-1](#) or [Figure 5-2](#).

8.2.2.3 Power Dissipation and Temperature

The number of coils driven is dependent on the coil current and on-chip power dissipation. The number of coils driven can be determined by [Figure 8-2](#).

For a more accurate determination of number of coils possible, use [Equation 2](#) to calculate ULQ200xA-Q1 device on-chip power dissipation P_D :

$$P_D = \sum_{i=1}^N V_{OLi} \times I_{Li} \quad (2)$$

where

- N is the number of channels active together
- V_{OLi} is the OUT_i pin voltage for the load current I_{Li} . This is the same as $V_{CE(SAT)}$

To ensure reliability of ULQ200xA-Q1 device and the system, the on-chip power dissipation must be lower than or equal to the maximum allowable power dissipation ($PD_{(MAX)}$) dictated by [Equation 3](#).

$$PD_{(MAX)} = \frac{(T_{J(MAX)} - T_A)}{\theta_{JA}} \quad (3)$$

where

- $T_{J(max)}$ is the target maximum junction temperature
- T_A is the operating ambient temperature
- $R_{\theta JA}$ is the package junction to ambient thermal resistance

Limit the die junction temperature of the ULQ200xA-Q1 device to less than 125°C. The IC junction temperature is directly proportional to the on-chip power dissipation.

8.2.3 Application Curve

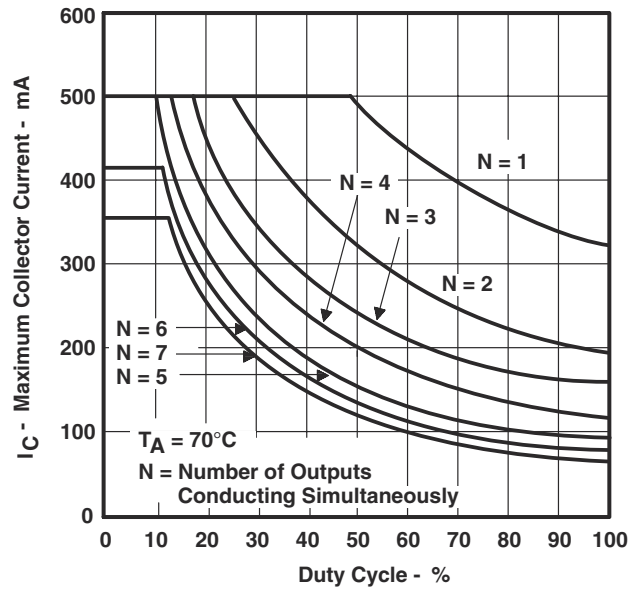

Figure 8-2. D Package Maximum Collector Current vs Duty Cycle

8.3 System Examples

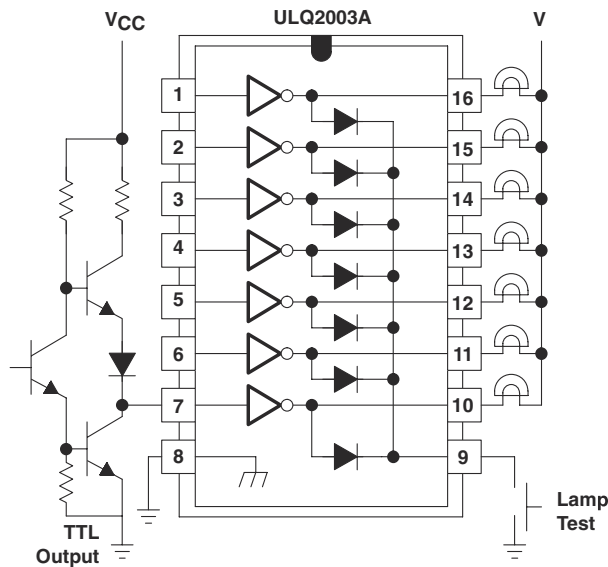

Figure 8-3. TTL to Load

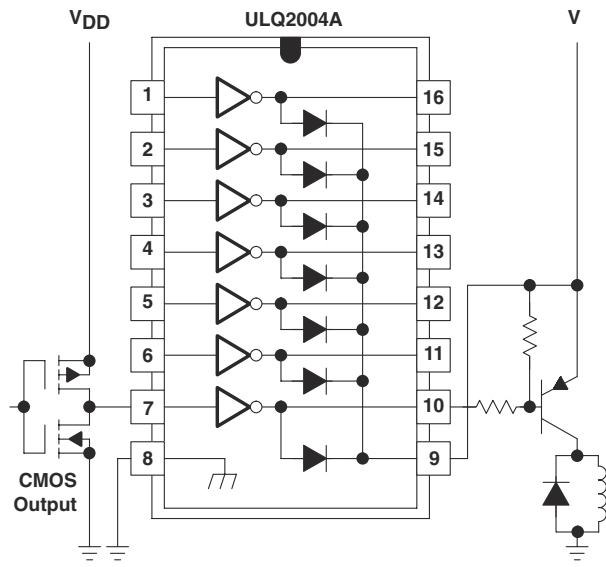

Figure 8-4. Buffer for Higher Current Loads

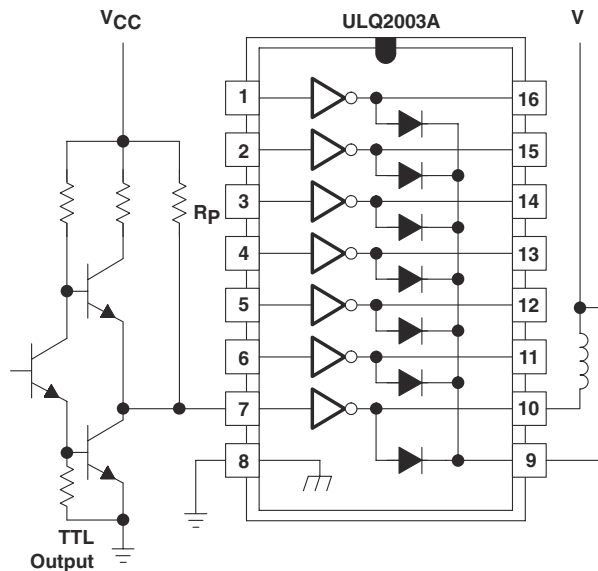

Figure 8-5. Use of Pullup Resistors to Increase Drive Current

8.4 Power Supply Recommendations

This device does not need a power supply. However, the COM pin is typically tied to the system power supply. When this is the case, it is very important to ensure that the output voltage does not heavily exceed the COM pin voltage. This discrepancy heavily forward biases the fly-back diodes and causes a large current to flow into COM, potentially damaging the on-chip metal or over-heating the device.

8.5 Layout

8.5.1 Layout Guidelines

Thin traces can be used on the input due to the low-current logic that is typically used to drive the ULQ200xA-Q1 devices. Take care to separate the input channels as much as possible, as to eliminate crosstalk. TI

recommends thick traces for the output to drive whatever high currents that may be needed. Wire thickness can be determined by the current density of the trace material and desired drive current.

Because all of the channels currents return to a common emitter, it is best to size that trace width to be very wide. Some applications require up to 2.5 A.

8.5.2 Layout Example

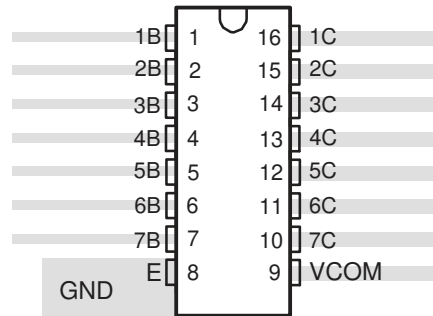

Figure 8-6. Package Layout

9 Device and Documentation Support

9.1 Related Links

The table below lists quick access links. Categories include technical documents, support and community resources, tools and software, and quick access to sample or buy.

Table 9-1. Related Links

PARTS	PRODUCT FOLDER	SAMPLE & BUY	TECHNICAL DOCUMENTS	TOOLS & SOFTWARE	SUPPORT & COMMUNITY
ULQ2003A-Q1	Click here	Click here	Click here	Click here	Click here
ULQ2004A-Q1	Click here	Click here	Click here	Click here	Click here

9.2 Support Resources

[TI E2E™ support forums](#) are an engineer's go-to source for fast, verified answers and design help — straight from the experts. Search existing answers or ask your own question to get the quick design help you need.

Linked content is provided "AS IS" by the respective contributors. They do not constitute TI specifications and do not necessarily reflect TI's views; see TI's [Terms of Use](#).

9.3 Trademarks

TI E2E™ is a trademark of Texas Instruments.
 All trademarks are the property of their respective owners.

9.4 Electrostatic Discharge Caution



This integrated circuit can be damaged by ESD. Texas Instruments recommends that all integrated circuits be handled with appropriate precautions. Failure to observe proper handling and installation procedures can cause damage.

ESD damage can range from subtle performance degradation to complete device failure. Precision integrated circuits may be more susceptible to damage because very small parametric changes could cause the device not to meet its published specifications.

9.5 Glossary

[TI Glossary](#) This glossary lists and explains terms, acronyms, and definitions.

10 Revision History

NOTE: Page numbers for previous revisions may differ from page numbers in the current version.

Changes from Revision E (November 2014) to Revision F (June 2024) **Page**

- Updated the numbering format for tables, figures, and cross-references throughout the document..... 1
- Added DYY package throughout the data sheet..... 1

Changes from Revision D (April 2010) to Revision E (November 2014) **Page**

- Added *Pin Configuration and Functions* section, *ESD Ratings* table, *Feature Description* section, *Device Functional Modes, Application and Implementation* section, *Power Supply Recommendations* section, *Layout* section, *Device and Documentation Support* section, and *Mechanical, Packaging, and Orderable Information* section 1

11 Mechanical, Packaging, and Orderable Information

The following pages include mechanical, packaging, and orderable information. This information is the most current data available for the designated devices. This data is subject to change without notice and revision of this document. For browser-based versions of this data sheet, refer to the left-hand navigation.

PACKAGING INFORMATION

Orderable Device	Status (1)	Package Type	Package Drawing	Pins	Package Qty	Eco Plan (2)	Lead finish/ Ball material (6)	MSL Peak Temp (3)	Op Temp (°C)	Device Marking (4/5)	Samples
ULQ2003AQDRQ1	ACTIVE	SOIC	D	16	2500	RoHS & Green	NIPDAU	Level-1-260C-UNLIM	-40 to 125	ULQ2003AQ	Samples
ULQ2003ATDG4Q1	OBSOLETE	SOIC	D	16		TBD	Call TI	Call TI	-40 to 105	ULQ2003AT	
ULQ2003ATDQ1	OBSOLETE	SOIC	D	16		TBD	Call TI	Call TI	-40 to 105	ULQ2003AT	
ULQ2003ATDRG4Q1	OBSOLETE	SOIC	D	16		TBD	Call TI	Call TI	-40 to 105	ULQ2003AT	
ULQ2003ATPWRQ1	ACTIVE	TSSOP	PW	16	2500	RoHS & Green	NIPDAU	Level-1-260C-UNLIM	-40 to 105	U2003AT	Samples
ULQ2004ATDRG4Q1	ACTIVE	SOIC	D	16	2500	RoHS & Green	NIPDAU	Level-1-260C-UNLIM	-40 to 105	ULQ2004AT	Samples
ULQ2004ATDRQ1	ACTIVE	SOIC	D	16	2500	RoHS & Green	NIPDAU	Level-1-260C-UNLIM	-40 to 105	ULQ2004AT	Samples

(1) The marketing status values are defined as follows:

ACTIVE: Product device recommended for new designs.

LIFEBUY: TI has announced that the device will be discontinued, and a lifetime-buy period is in effect.

NRND: Not recommended for new designs. Device is in production to support existing customers, but TI does not recommend using this part in a new design.

PREVIEW: Device has been announced but is not in production. Samples may or may not be available.

OBSOLETE: TI has discontinued the production of the device.

(2) **RoHS:** TI defines "RoHS" to mean semiconductor products that are compliant with the current EU RoHS requirements for all 10 RoHS substances, including the requirement that RoHS substance do not exceed 0.1% by weight in homogeneous materials. Where designed to be soldered at high temperatures, "RoHS" products are suitable for use in specified lead-free processes. TI may reference these types of products as "Pb-Free".

RoHS Exempt: TI defines "RoHS Exempt" to mean products that contain lead but are compliant with EU RoHS pursuant to a specific EU RoHS exemption.

Green: TI defines "Green" to mean the content of Chlorine (Cl) and Bromine (Br) based flame retardants meet JS709B low halogen requirements of <=1000ppm threshold. Antimony trioxide based flame retardants must also meet the <=1000ppm threshold requirement.

(3) MSL, Peak Temp. - The Moisture Sensitivity Level rating according to the JEDEC industry standard classifications, and peak solder temperature.

(4) There may be additional marking, which relates to the logo, the lot trace code information, or the environmental category on the device.

(5) Multiple Device Markings will be inside parentheses. Only one Device Marking contained in parentheses and separated by a "~" will appear on a device. If a line is indented then it is a continuation of the previous line and the two combined represent the entire Device Marking for that device.

(6) Lead finish/Ball material - Orderable Devices may have multiple material finish options. Finish options are separated by a vertical ruled line. Lead finish/Ball material values may wrap to two lines if the finish value exceeds the maximum column width.

Important Information and Disclaimer: The information provided on this page represents TI's knowledge and belief as of the date that it is provided. TI bases its knowledge and belief on information provided by third parties, and makes no representation or warranty as to the accuracy of such information. Efforts are underway to better integrate information from third parties. TI has taken and continues to take reasonable steps to provide representative and accurate information but may not have conducted destructive testing or chemical analysis on incoming materials and chemicals. TI and TI suppliers consider certain information to be proprietary, and thus CAS numbers and other limited information may not be available for release.

In no event shall TI's liability arising out of such information exceed the total purchase price of the TI part(s) at issue in this document sold by TI to Customer on an annual basis.

OTHER QUALIFIED VERSIONS OF ULQ2003A-Q1, ULQ2004A-Q1 :

- Catalog : [ULQ2003A](#), [ULQ2004A](#)

NOTE: Qualified Version Definitions:

- Catalog - TI's standard catalog product

IMPORTANT NOTICE AND DISCLAIMER

TI PROVIDES TECHNICAL AND RELIABILITY DATA (INCLUDING DATA SHEETS), DESIGN RESOURCES (INCLUDING REFERENCE DESIGNS), APPLICATION OR OTHER DESIGN ADVICE, WEB TOOLS, SAFETY INFORMATION, AND OTHER RESOURCES "AS IS" AND WITH ALL FAULTS, AND DISCLAIMS ALL WARRANTIES, EXPRESS AND IMPLIED, INCLUDING WITHOUT LIMITATION ANY IMPLIED WARRANTIES OF MERCHANTABILITY, FITNESS FOR A PARTICULAR PURPOSE OR NON-INFRINGEMENT OF THIRD PARTY INTELLECTUAL PROPERTY RIGHTS.

These resources are intended for skilled developers designing with TI products. You are solely responsible for (1) selecting the appropriate TI products for your application, (2) designing, validating and testing your application, and (3) ensuring your application meets applicable standards, and any other safety, security, regulatory or other requirements.

These resources are subject to change without notice. TI grants you permission to use these resources only for development of an application that uses the TI products described in the resource. Other reproduction and display of these resources is prohibited. No license is granted to any other TI intellectual property right or to any third party intellectual property right. TI disclaims responsibility for, and you will fully indemnify TI and its representatives against, any claims, damages, costs, losses, and liabilities arising out of your use of these resources.

TI's products are provided subject to [TI's Terms of Sale](#) or other applicable terms available either on [ti.com](https://www.ti.com) or provided in conjunction with such TI products. TI's provision of these resources does not expand or otherwise alter TI's applicable warranties or warranty disclaimers for TI products.

TI objects to and rejects any additional or different terms you may have proposed.

Mailing Address: Texas Instruments, Post Office Box 655303, Dallas, Texas 75265
Copyright © 2024, Texas Instruments Incorporated