

AM26LS32Ax、AM26LS33Ax 四路差分线路接收器

1 特性

- AM26LS32A 器件符合或超出 ANSI TIA/EIA-422-B、TIA/EIA-423-B，以及 ITU 建议 V.10 和 V.11 的要求
- AM26LS32A 器件的共模范围为 $\pm 7V$ 、灵敏度为 $\pm 200mV$
- AM26LS33A 器件的共模范围为 $\pm 15V$ 、灵敏度为 $\pm 500mV$
- 输入迟滞 50mV (典型值)
- 由一个 5V 单电源供电运行
- 低功耗肖特基电路
- 三态输出
- 互补输出使能输入
- 输入阻抗 12k Ω (最小值)
- 开路输入失效防护

2 应用

- 高可靠性汽车应用
- 工厂自动化
- ATM 和点钞机
- 智能电网
- 交流和伺服电机驱动器

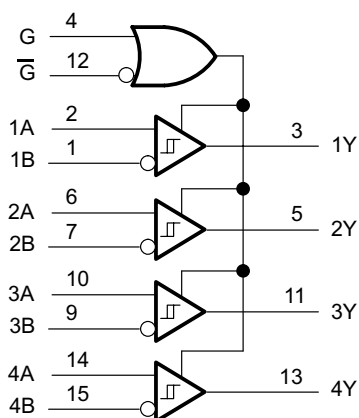

Copyright © 2016, Texas Instruments Incorporated

引脚数量只适用于 D、N、NS 或 PW 封装。

逻辑图 (正逻辑)

3 说明

AM26LS32Ax 和 AM26LS33Ax 器件是用于平衡和不平衡数字数据传输的四路差分线路接收器。四个接收器均具有使能功能，该功能提供了两种可选输入：高电平有效输入和低电平有效输入。通过三态输出，该器件可直接连接至总线组织式系统。当输入处于开路状态时，失效防护设计可确保输出始终为高电平。

与 AM26LS32 和 AM26LS33 相比，AM26LS32A 和 AM26LS33A 增加了一个放大级以提高灵敏度。输入阻抗已增加，从而减少了总线负载。附加级增加了传播延迟；然而，这并不影响大多数应用中的互换性。

AM26LS32AC 和 AM26LS33AC 的特点是可在 0°C 至 70°C 的温度范围内运行。AM26LS32AI 的特点是可在 -40°C 至 85°C 的温度范围内运行。AM26LS32AM 和 AM26LS33AM 的特点是可在 -55°C 至 125°C 的整个军用温度范围内运行。

封装信息

器件型号	封装 ⁽¹⁾	封装尺寸 ⁽²⁾
AM26LS3xAC AM26LS32AI	PDIP (16)	19.3mm × 9.4mm
	SOIC (16)	9.9mm × 6mm
AM26LS32AC	SO (16)	10.2mm × 7.8mm
	TSSOP (16)	5mm × 6.4mm
AM26LS3xAM	CDIP (16)	19.56mm × 6.92mm
	LCCC (20)	8.9mm × 8.9mm

- 如需了解所有可用封装，请参阅数据表末尾的可订购产品附录。
- 封装尺寸 (长 × 宽) 为标称值，并包括引脚 (如适用)。



Table of Contents

1 特性.....	1	8.2 Functional Block Diagram.....	12
2 应用.....	1	8.3 Feature Description.....	12
3 说明.....	1	8.4 Device Functional Modes.....	12
4 Revision History.....	2	9 Application and Implementation.....	13
5 Pin Configuration and Functions.....	3	9.1 Application Information.....	13
6 Specifications.....	4	9.2 Typical Application.....	13
6.1 Absolute Maximum Ratings.....	4	9.3 Power Supply Recommendations.....	14
6.2 ESD Ratings.....	4	9.4 Layout.....	14
6.3 Recommended Operating Conditions.....	4	10 Device and Documentation Support.....	16
6.4 Thermal Information.....	5	10.1 接收文档更新通知.....	16
6.5 Electrical Characteristics.....	6	10.2 支持资源.....	16
6.6 Switching Characteristics.....	7	10.3 Trademarks.....	16
6.7 Dissipation Ratings.....	7	10.4 静电放电警告.....	16
6.8 Typical Characteristics.....	8	10.5 术语表.....	16
7 Parameter Measurement Information.....	10	11 Mechanical, Packaging, and Orderable	
8 Detailed Description.....	12	Information.....	16
8.1 Overview.....	12		

4 Revision History

注：以前版本的页码可能与当前版本的页码不同

Changes from Revision F (August 2016) to Revision G (August 2023)	Page
• 将“器件信息”表更改为封装信息表.....	1
• Changed the <i>Thermal Information</i> table.....	5
• Changed the <i>Typical Characteristics</i>	8

Changes from Revision E (October 2007) to Revision F (August 2016)	Page
• 添加了应用部分、ESD 等级表、特性说明部分、器件功能模式、应用和实施部分、电源相关建议部分、布局部分、器件和文档支持部分以及机械、封装和可订购信息部分.....	1
• Changed $R_{\theta JA}$ values in the <i>Thermal Information</i> table: 73 to 75.7 for (D), 67 to 45.3 (N), 64 to 75.8 (NS), and 108 to 102.7 (PW).....	5

5 Pin Configuration and Functions



图 5-1. D, J, N, NS, and PW Package 16-Pin SOIC, CDIP, PDIP, SO, and TSSOP (Top View)



NC - No internal connection

图 5-2. FK Package, 20-Pin LCCC (Top View)

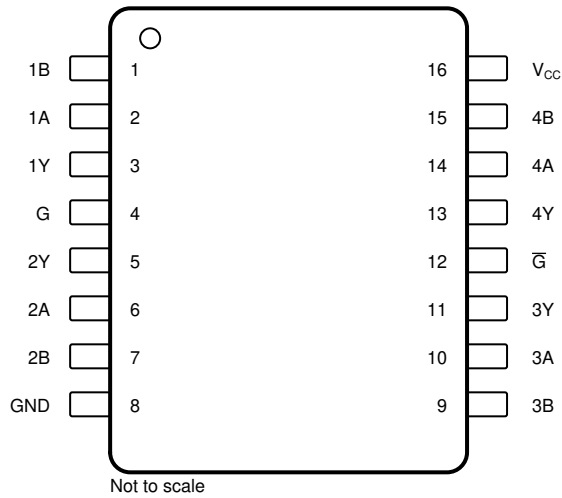
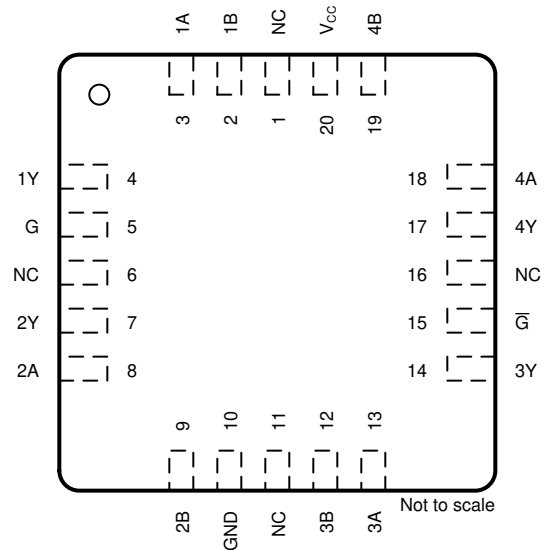
NAME	PIN		TYPE	DESCRIPTION
	SOIC, CDIP, PDIP, SO, TSSOP	LCCC		
1A	2	3	I	RS422/RS485 differential input (noninverting)
1B	1	2	I	RS422/RS485 differential input (inverting)
1Y	3	4	O	Logic level output
2A	6	8	I	RS422/RS485 differential input (noninverting)
2B	7	9	I	RS422/RS485 differential input (inverting)
2Y	5	7	O	Logic level output
3A	10	13	I	RS422/RS485 differential input (noninverting)
3B	9	12	I	RS422/RS485 differential input (inverting)
3Y	11	14	O	Logic level output
4A	14	18	I	RS422/RS485 differential input (noninverting)
4B	15	19	I	RS422/RS485 differential input (inverting)
4Y	13	17	O	Logic level output
Ḡ	12	15	I	Active-Low select
G	4	5	I	Active-High select
GND	8	10	—	Ground
NC	—	1, 6, 11, 16	—	No internal connection
V _{CC}	16	20	—	Power supply

6 Specifications

6.1 Absolute Maximum Ratings

over operating free-air temperature range (unless otherwise noted)⁽¹⁾

		MIN	MAX	UNIT
Supply voltage, V_{CC} ⁽²⁾			7	V
Input voltage, V_I	Any differential input		±25	V
	Other inputs		7	
Differential input voltage, V_{ID} ⁽³⁾			±25	V
Continuous total power dissipation		See # 6.7		
Case temperature, T_C , FK package (60 s)			260	°C
Lead temperature ⁽⁴⁾	D or N package (10 s)		260	°C
	J package (60 s)		300	
Storage temperature, T_{stg}		- 65	150	°C

- (1) Stresses beyond those listed under *Absolute Maximum Ratings* may cause permanent damage to the device. These are stress ratings only, which do not imply functional operation of the device at these or any other conditions beyond those indicated under *Recommended Operating Conditions*. Exposure to absolute-maximum-rated conditions for extended periods may affect device reliability.
- (2) All voltage values, except differential voltages, are with respect to the network ground terminal.
- (3) Differential voltage values are at the noninverting (A) input terminals with respect to the inverting (B) input terminals.
- (4) 1.6 mm (1/16 inch) from case

6.2 ESD Ratings

		VALUE	UNIT
$V_{(ESD)}$ Electrostatic discharge	Human-body model (HBM), per ANSI/ESDA/JEDEC JS-001 ⁽¹⁾	±500	V
	Charged-device model (CDM), per JEDEC specification JESD22-C101 ⁽²⁾	±2000	

- (1) JEDEC document JEP155 states that 500-V HBM allows safe manufacturing with a standard ESD control process.
- (2) JEDEC document JEP157 states that 250-V CDM allows safe manufacturing with a standard ESD control process.

6.3 Recommended Operating Conditions

		MIN	NOM	MAX	UNIT
V_{CC} Supply voltage	AM26LS32AC, AM26LS32AI, AM26LS33AC	4.75	5	5.25	V
	AM26LS32AM, AM26LS33AM	4.5	5	5.5	
V_{IH} High-level input voltage		2			V
V_{IL} Low-level input voltage				0.8	V
V_{IC} Common-mode input voltage	AM26LS32A			±7	V
	AM26LS33A			±15	
I_{OH} High-level output current				- 440	µA
I_{OL} Low-level output current				8	mA
T_A Operating free-air temperature	AM26LS32AC, AM26LS33AC	0		70	°C
	AM26LS32AI	- 40		85	
	AM26LS32AM, AM26LS33AM	- 55		125	

6.4 Thermal Information

THERMAL METRIC ⁽¹⁾	AM26LS3xAC, AM26LS32AI				AM26LS32AC				UNIT	
	D (SOIC)	DR (SOIC-Reel)	N (PDIP)	NR (PDIP-Reel)	NS (SO)	NSR (SO-Reel)	PW (TSSOP)	PWR (TSSOP-Reel)		
	16 PINS	16 PINS	16 PINS	16 PINS	16 PINS	16 PINS	16 PINS	16 PINS		
$R_{\theta JA}$	Junction-to-ambient thermal resistance	75.7	84.6	45.3	60.6	75.8	88.5	102.7	107.5	°C/W
$R_{\theta JC(top)}$	Junction-to-case (top) thermal resistance	35	43.5	32.7	48.1	32.9	46.2	37.8	38.4	°C/W
$R_{\theta JB}$	Junction-to-board thermal resistance	33.3	43.2	25.3	40.6	36.6	50.7	47.7	53.7	°C/W
ψ_{JT}	Junction-to-top characterization parameter	6.6	10.4	17.8	27.5	6	13.5	3	3.2	°C/W
ψ_{JB}	Junction-to-board characterization parameter	33	42.8	25.1	40.3	36.3	50.3	47.1	53.1	°C/W

- (1) For more information about traditional and new thermal metrics, see the [Semiconductor and IC Package Thermal Metrics](#) application report.

6.5 Electrical Characteristics

over recommended ranges of V_{CC} , V_{IC} , and operating free-air temperature (unless otherwise noted)

PARAMETER		TEST CONDITIONS		MIN	TYP ⁽¹⁾	MAX	UNIT
V_{IT+}	Positive-going input threshold voltage	$V_O = V_{OHmin}$, $I_{OH} = -440 \mu A$	AM26LS32A			0.2	V
			AM26LS33A			0.5	
V_{IT-}	Negative-going input threshold voltage	$V_O = 0.45 V$, $I_{OL} = 8 mA$	AM26LS32A			-0.2 ⁽²⁾	V
			AM26LS33A			-0.5 ⁽²⁾	
V_{hys}	Hysteresis voltage ($V_{IT+} - V_{IT-}$)				50		mV
V_{IK}	Enable-input clamp voltage	$V_{CC} = MIN$, $I_I = -18 mA$				-1.5	V
V_{OH}	High-level output voltage	$V_{CC} = MIN$, $V_{ID} = 1 V$, $V_{I(G)} = 0.8 V$, $I_{OH} = -440 \mu A$	AM26LS32AC, AM26LS33AC			2.7	V
			AM26LS32AM, AM26LS32AI, AM26LS33AM			2.5	
V_{OL}	Low-level output voltage	$V_{CC} = MIN$, $V_{ID} = -1 V$, $V_{I(G)} = 0.8 V$	$I_{OL} = 4 mA$			0.4	V
			$I_{OL} = 8 mA$			0.45	
I_{OZ}	Off-state (high-impedance state) output current	$V_{CC} = MAX$	$V_O = 2.4 V$			20	μA
			$V_O = 0.4 V$			-20	
I_I	Line input current	$V_I = 15 V$, other input at $-10 V$ to $15 V$				1.2	mA
			$V_I = -15 V$, other input at $-15 V$ to $10 V$				
$I_{I(EN)}$	Enable input current	$V_I = 5.5 V$				100	μA
I_H	High-level enable current	$V_I = 2.7 V$				20	μA
I_L	Low-level enable current	$V_I = 0.4 V$				-0.36	mA
r_i	Input resistance	$V_{IC} = -15 V$ to $15 V$, one input to ac ground			12	15	k Ω
I_{OS}	Short-circuit output current ⁽³⁾	$V_{CC} = MAX$			-15	-85	mA
I_{CC}	Supply current	$V_{CC} = MAX$, all outputs disabled			52	70	mA

(1) All typical values are at $V_{CC} = 5 V$, $T_A = 25^\circ C$, and $V_{IC} = 0$.

(2) The algebraic convention, in which the less positive (more negative) limit is designated as minimum, is used in this data sheet for threshold levels only.

(3) Not more than one output must be shorted to ground at a time, and duration of the short circuit must not exceed one second.

6.6 Switching Characteristics

$C_L = 15 \text{ pF}$, $V_{CC} = 5 \text{ V}$, and $T_A = 25^\circ\text{C}$ (see [# 7](#); unless otherwise noted)

PARAMETER		MIN	TYP ⁽¹⁾	MAX	UNIT
t_{PLH}	Propagation delay time, low-to-high-level output		20	35	ns
t_{PHL}	Propagation delay time, high-to-low-level output		22	35	ns
t_{PZH}	Output enable time to high level		17	22	ns
t_{PZL}	Output enable time to low level		20	25	ns
t_{PHZ}	Output disable time from high level		21	30	ns
t_{PLZ}	Output disable time from low level		30	40	ns

(1) All typical values are at $V_{CC} = 5 \text{ V}$, $T_A = 25^\circ\text{C}$, and $V_{IC} = 0$.

6.7 Dissipation Ratings

PACKAGE	$T_A \leq 25^\circ\text{C}$ POWER RATING	DERATION FACTOR ABOVE $T_A = 25^\circ\text{C}$	$T_A = 70^\circ\text{C}$ POWER RATING	$T_A = 125^\circ\text{C}$ POWER RATING
FK	1375 mW	11 mW/°C	880 mW	275 mW
J	1375 mW	11 mW/°C	880 mW	275 mW

6.8 Typical Characteristics



图 6-1. High-Level Output Voltage vs High-Level Output Current



图 6-2. Low-Level Output Voltage vs Low-Level Output Current

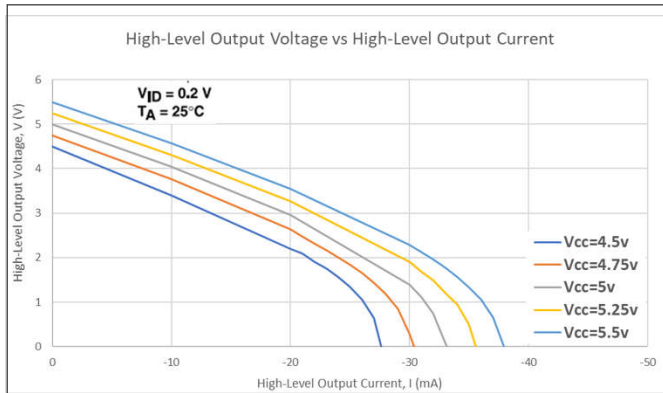

图 6-3. Low-Level Output Voltage vs Free-Air Temperature

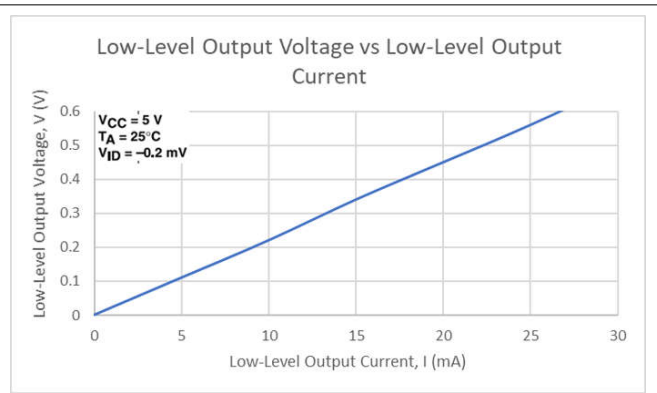

图 6-4. Output Voltage vs Enable G Voltage

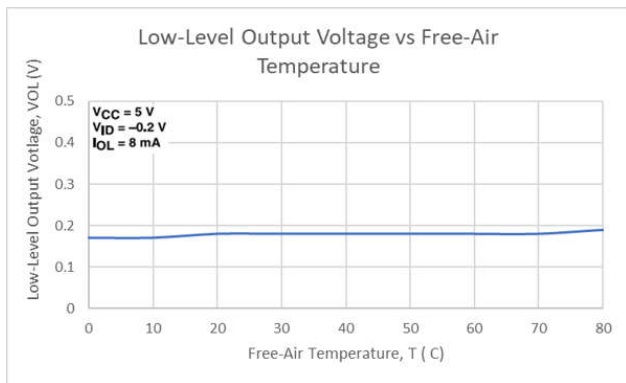

图 6-5. Output Voltage vs Enable G Voltage

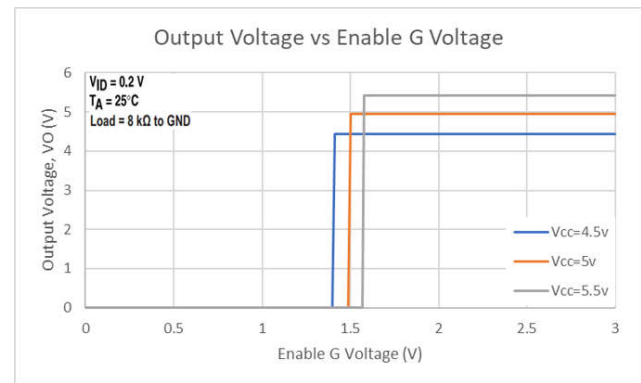

图 6-6. Output Voltage vs Enable G Voltage

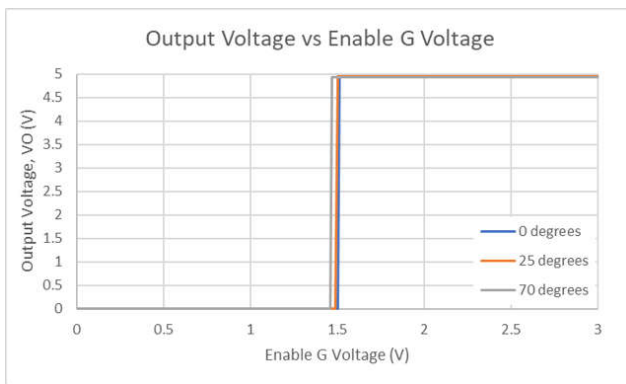

图 6-7. Output Voltage vs Enable G Voltage

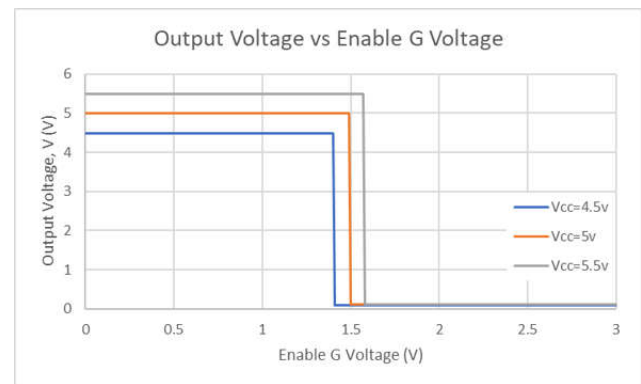

图 6-8. AM26LS32A Output Voltage vs Differential Input Voltage

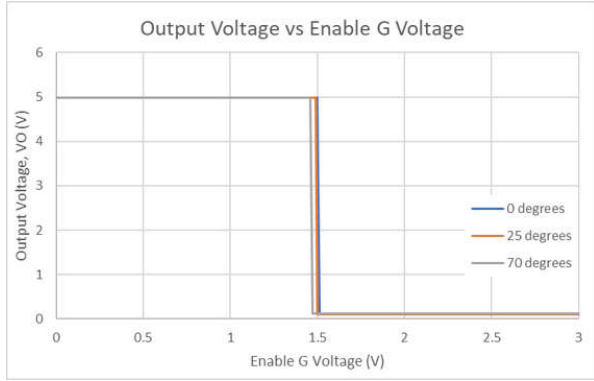

图 6-9. AM26LS33A Output Voltage vs Differential Input Voltage

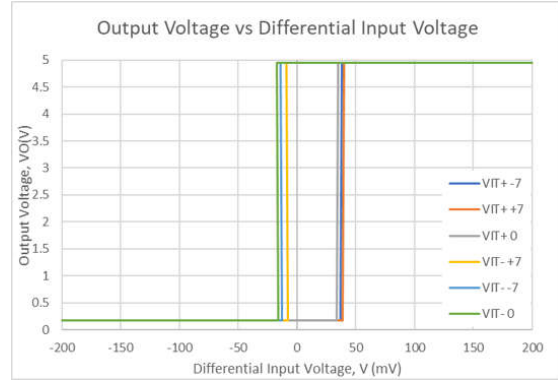

The unshaded area shows requirements of paragraph 4.2.1 of ANSI Standards EIA/TIA-422-B and EIA/TIA-423-B.

图 6-10. Input Current vs Input Voltage

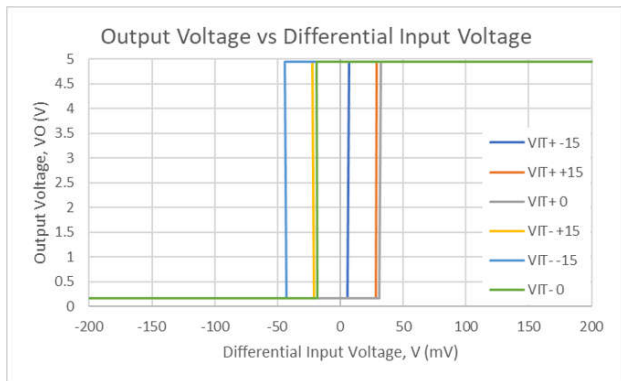
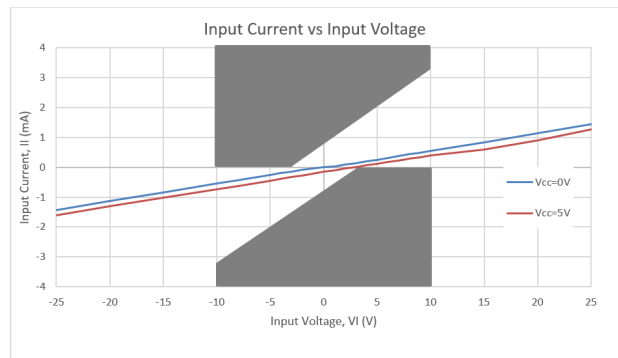
7 Parameter Measurement Information



图 7-1. Test Circuit



图 7-2. Voltage Waveforms For t_{PLH} , t_{PHL}

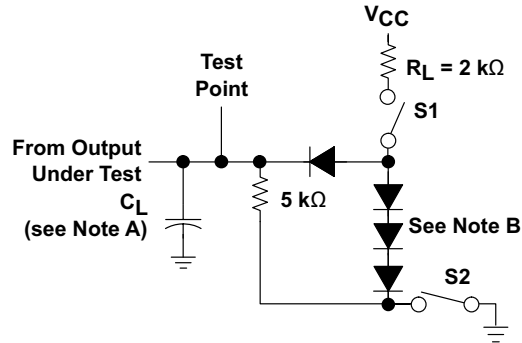

图 7-3. Voltage Waveforms For t_{PHZ} , t_{PZH}

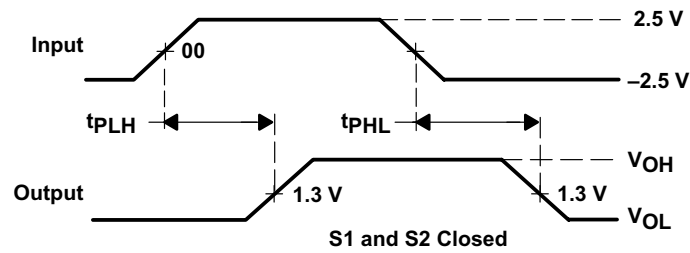

- A. CL includes probe and jig capacitance.
- B. All diodes are 1N3064 or equivalent.
- C. Enable G is tested with \bar{G} high, \bar{G} is tested with G low.

图 7-4. Voltage Waveforms For t_{PLZ} , t_{PZL}

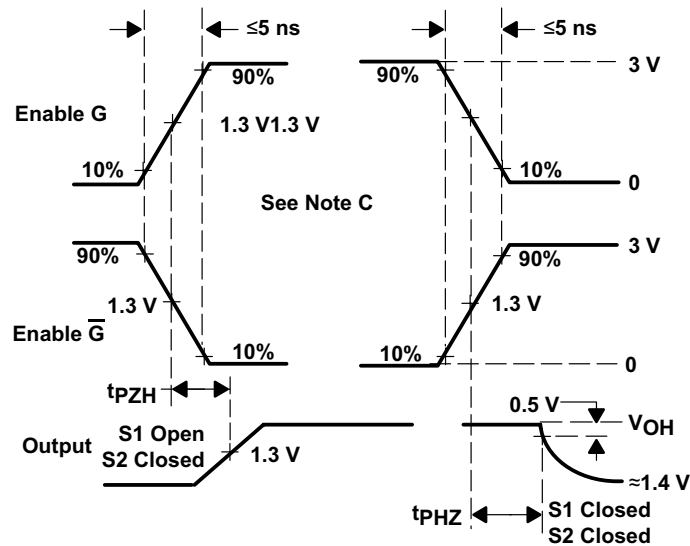
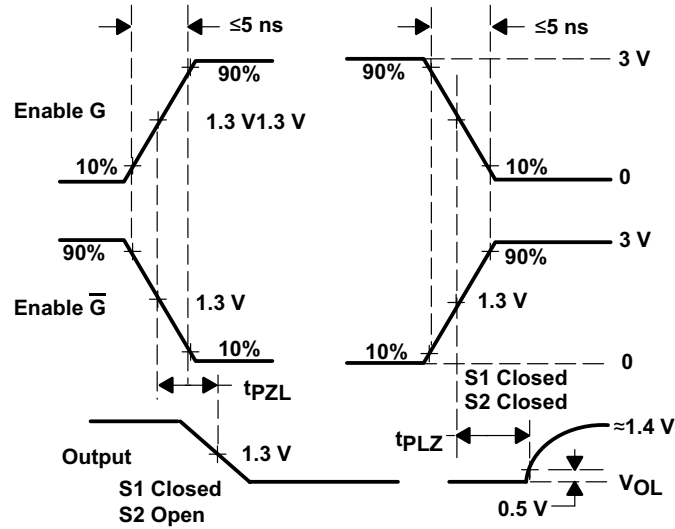
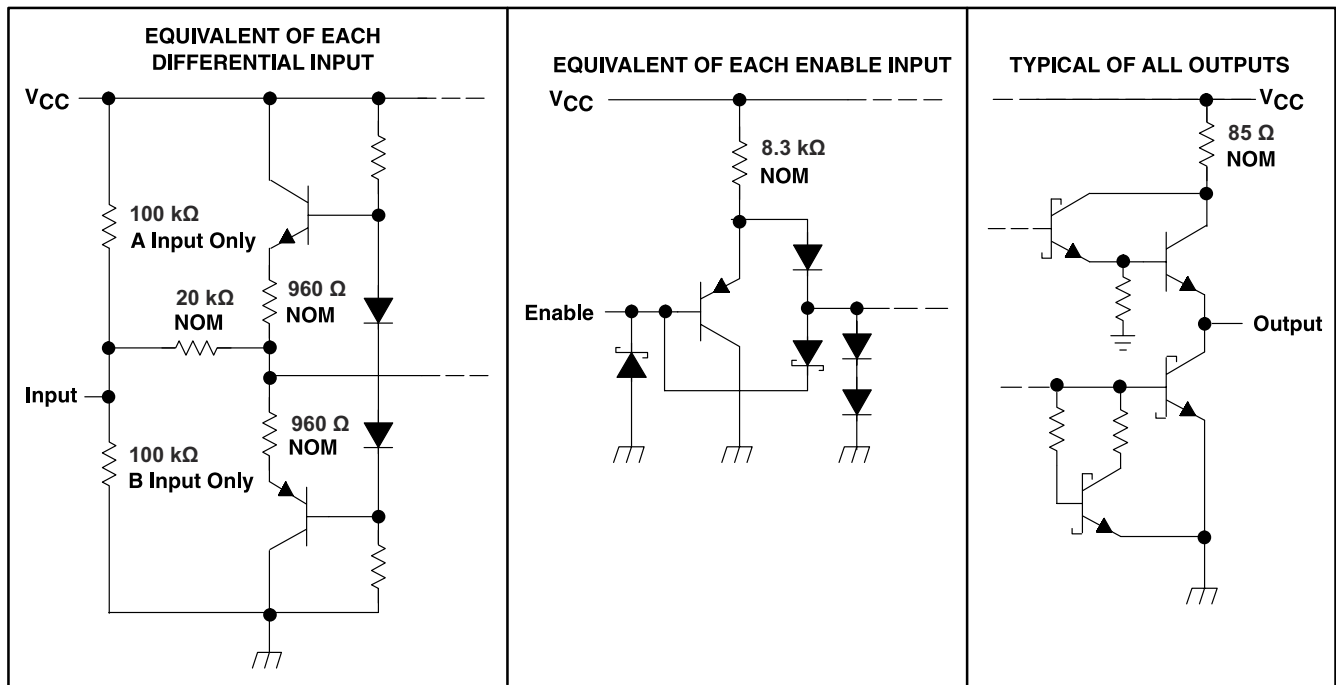

Copyright © 2016, Texas Instruments Incorporated

图 7-5. Schematics of Inputs and Outputs

8 Detailed Description

8.1 Overview

The AM26LS32 is a quadruple-differential line receiver that meets the necessary requirements for NSI TIA/EIA-422-B, TIA/EIA-423-B, and ITU Recommendation V.10 and V.11. This device allows a low-power or low-voltage MCU to interface with heavy machinery, subsystems, and other devices through long wires of up to 1000 m, giving any design a reliable and easy-to-use connection. As any RS422 interface, the AM26LS32 works in a differential voltage range, which enables very good signal integrity.

8.2 Functional Block Diagram

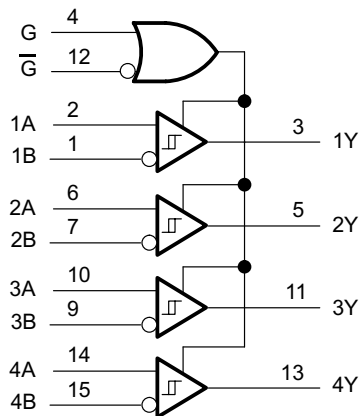

Copyright © 2016, Texas Instruments Incorporated

图 8-1. Logic Diagram (Positive Logic)

8.3 Feature Description

The device can be configured using the G and \bar{G} logic inputs to select receiver output. The high voltage or logic 1 on the G pin allows the device to operate on an active-high, and having a low voltage or logic 0 on the G enables active low operation. These are simple ways to configure the logic to match that of the receiving or transmitting controller or microprocessor.

8.4 Device Functional Modes

The receivers implemented in these RS422 devices can be configured using the G and \bar{G} logic pins to be enabled or disabled. This allows users to ignore or filter out transmissions as desired.

表 8-1. Function Table, Each Receiver

DIFFERENTIAL A - B	ENABLES ⁽¹⁾		OUTPUT ⁽¹⁾ Y
	G	\bar{G}	
$V_{ID} \geq V_{IT+}$	H	X	H
	X	L	H
$V_{IT-} \leq V_{ID} \leq V_{IT+}$	H	X	?
	X	L	?
$V_{ID} \leq V_{IT-}$	H	X	L
	X	L	L
X	L	H	Z
Open	H	X	H
	X	L	H

(1) H = High level, L = Low level, X = Irrelevant, Z = High impedance (off), ? = Indeterminate

9 Application and Implementation

备注

以下应用部分中的信息不属于 TI 器件规格的范围，TI 不担保其准确性和完整性。TI 的客户应负责确定器件是否适用于其应用。客户应验证并测试其设计，以确保系统功能。

9.1 Application Information

When using AM26LS32A as a receiver, the AM26LS31AC can allow multiple AM26LS32As to be used causing an increase in the amount of outputs.

9.2 Typical Application

图 9-1 shows a configuration with no termination. Although reflections are present at the receiver inputs at a data signaling rate of 200 kbps with no termination, the RS-422-compliant receiver reads only the input differential voltage and produces a clean signal at the output.

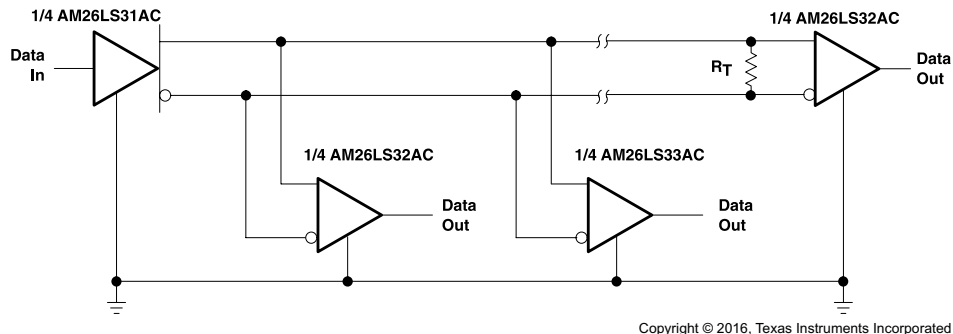

Copyright © 2016, Texas Instruments Incorporated

[†] R_T equals the characteristic impedance of the line.

图 9-1. Application Diagram

9.2.1 Design Requirements

Resistor and capacitor (if used) termination values are shown for each laboratory experiment, but vary from system to system. For example, the termination resistor, R_T , must be within 20% of the characteristic impedance, Z_O , of the cable and can vary from about 80 Ω to 120 Ω .

9.2.2 Detailed Design Procedure

Add a V_{CC} bypass capacitor (0.1 μF or more). Either enable (G pin) input can turn on the receivers, so connect the desired enable to a compatible logic line output. The other enable input must be tied to the inactive state supply rail. If the receivers must always be active, then connect both enables to the supply rail such that at least one is set to an active-state rail. V_{CC} must be 5 V within 10% and logic inputs must provide TTL-compatible voltage levels A & B Inputs can lead to an external connector or can be left unconnected. The last receiver on a cable requires termination, either on-board or use as an external resistor. Unused Y outputs can be left unconnected.

9.2.3 Application Curve



图 9-2. High-Level Output Voltage vs Free-Air Temperature

9.3 Power Supply Recommendations

Place 0.1- μ F bypass capacitors close to the power-supply pins to reduce errors coupling in from noisy or high-impedance power supplies.

9.4 Layout

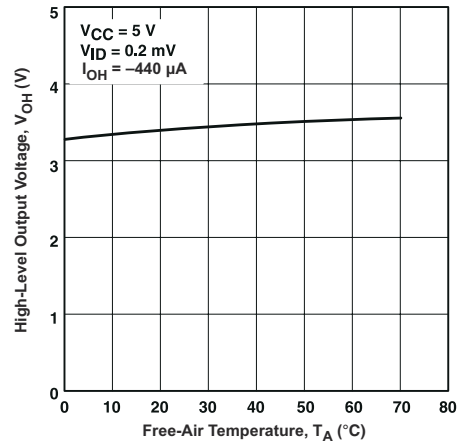
9.4.1 Layout Guidelines

For best operational performance of the device, use good PCB layout practices including:

- Noise can propagate into analog circuitry through the power pins of the circuit as a whole, as well as the operational amplifier. Bypass capacitors are used to reduce the coupled noise by providing low impedance power sources local to the analog circuitry.
- Connect low-ESR, 0.1- μ F ceramic bypass capacitors between each supply pin and ground, placed as close to the device as possible. A single bypass capacitor from $V+$ to ground is applicable for single supply applications.
- Separate grounding for analog and digital portions of circuitry is one of the simplest and most-effective methods of noise suppression. One or more layers on multilayer PCBs are usually devoted to ground planes. A ground plane helps distribute heat and reduces EMI noise pickup. Make sure to physically separate digital and analog grounds, paying attention to the flow of the ground current.
- To reduce parasitic coupling, run the input traces as far away from the supply or output traces as possible. If it is not possible to keep them separate, it is much better to cross the sensitive trace perpendicular as opposed to in parallel with the noisy trace.
- Place the external components as close to the device as possible. Keeping RF and RG close to the inverting input minimizes parasitic capacitance.
- Keep the length of input traces as short as possible. Always remember that the input traces are the most sensitive part of the circuit.
- Consider a driven, low-impedance guard ring around the critical traces. A guard ring can significantly reduce leakage currents from nearby traces that are at different potentials.

9.4.2 Layout Example



图 9-3. Layout with PCB Recommendations

10 Device and Documentation Support

10.1 接收文档更新通知

要接收文档更新通知，请导航至 [ti.com](https://www.ti.com) 上的器件产品文件夹。点击 [订阅更新](#) 进行注册，即可每周接收产品信息更改摘要。有关更改的详细信息，请查看任何已修订文档中包含的修订历史记录。

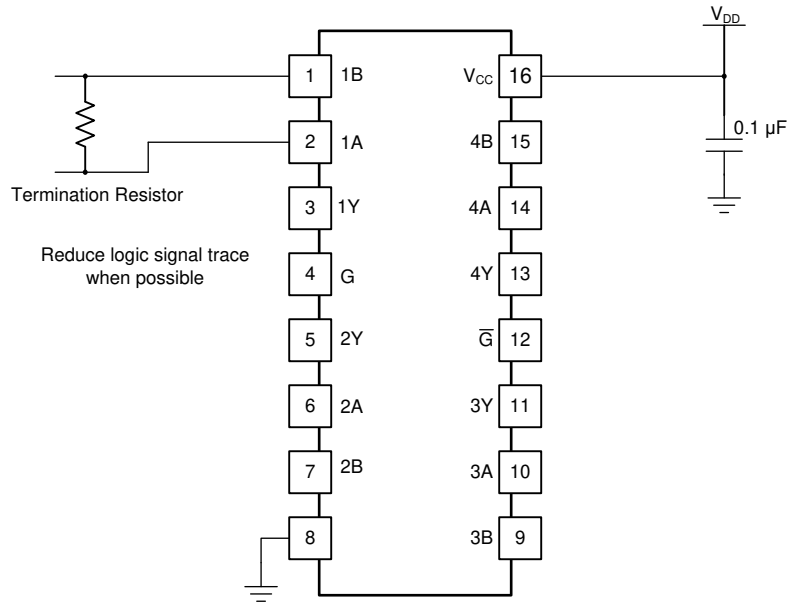
10.2 支持资源

TI E2E™ [支持论坛](#) 是工程师的重要参考资料，可直接从专家获得快速、经过验证的解答和设计帮助。搜索现有解答或提出自己的问题可获得所需的快速设计帮助。

链接的内容由各个贡献者“按原样”提供。这些内容并不构成 TI 技术规范，并且不一定反映 TI 的观点；请参阅 TI 的 [《使用条款》](#)。

10.3 Trademarks

TI E2E™ is a trademark of Texas Instruments.
所有商标均为其各自所有者的财产。

10.4 静电放电警告



静电放电 (ESD) 会损坏这个集成电路。德州仪器 (TI) 建议通过适当的预防措施处理所有集成电路。如果不遵守正确的处理和安装程序，可能会损坏集成电路。

ESD 的损坏小至导致微小的性能降级，大至整个器件故障。精密的集成电路可能更容易受到损坏，这是因为非常细微的参数更改都可能会导致器件与其发布的规格不相符。

10.5 术语表

[TI 术语表](#) 本术语表列出并解释了术语、首字母缩略词和定义。

11 Mechanical, Packaging, and Orderable Information

The following pages include mechanical, packaging, and orderable information. This information is the most current data available for the designated devices. This data is subject to change without notice and revision of this document. For browser-based versions of this data sheet, refer to the left-hand navigation.

PACKAGING INFORMATION

Orderable Device	Status (1)	Package Type	Package Drawing	Pins	Package Qty	Eco Plan (2)	Lead finish/ Ball material (6)	MSL Peak Temp (3)	Op Temp (°C)	Device Marking (4/5)	Samples
5962-7802003M2A	ACTIVE	LCCC	FK	20	55	Non-RoHS & Green	SNPB	N / A for Pkg Type	-55 to 125	5962- 7802003M2A AM26LS 32AMFKB	Samples
5962-7802003MEA	ACTIVE	CDIP	J	16	25	Non-RoHS & Green	SNPB	N / A for Pkg Type	-55 to 125	5962-7802003ME A AM26LS32AMJB	Samples
5962-7802003MFA	ACTIVE	CFP	W	16	25	Non-RoHS & Green	SNPB	N / A for Pkg Type	-55 to 125	5962-7802003MF A AM26LS32AMWB	Samples
5962-7802004M2A	ACTIVE	LCCC	FK	20	55	Non-RoHS & Green	SNPB	N / A for Pkg Type	-55 to 125	5962- 7802004M2A AM26LS 33AMFKB	Samples
5962-7802004MEA	ACTIVE	CDIP	J	16	25	Non-RoHS & Green	SNPB	N / A for Pkg Type	-55 to 125	5962-7802004ME A AM26LS33AMJB	Samples
5962-7802004MFA	ACTIVE	CFP	W	16	25	Non-RoHS & Green	SNPB	N / A for Pkg Type	-55 to 125	5962-7802004MF A AM26LS33AMWB	Samples
AM26LS32ACD	OBSOLETE	SOIC	D	16		TBD	Call TI	Call TI	0 to 70	26LS32AC	
AM26LS32ACDR	ACTIVE	SOIC	D	16	2500	RoHS & Green	NIPDAU	Level-1-260C-UNLIM	0 to 70	26LS32AC	Samples
AM26LS32ACDRE4	ACTIVE	SOIC	D	16	2500	RoHS & Green	NIPDAU	Level-1-260C-UNLIM	0 to 70	26LS32AC	Samples
AM26LS32ACDRG4	ACTIVE	SOIC	D	16	2500	RoHS & Green	NIPDAU	Level-1-260C-UNLIM	0 to 70	26LS32AC	Samples
AM26LS32ACN	ACTIVE	PDIP	N	16	25	RoHS & Green	NIPDAU	N / A for Pkg Type	0 to 70	AM26LS32ACN	Samples
AM26LS32ACNSR	ACTIVE	SO	NS	16	2000	RoHS & Green	NIPDAU	Level-1-260C-UNLIM	0 to 70	26LS32A	Samples
AM26LS32ACNSRG4	ACTIVE	SO	NS	16	2000	RoHS & Green	NIPDAU	Level-1-260C-UNLIM	0 to 70	26LS32A	Samples
AM26LS32ACPW	OBSOLETE	TSSOP	PW	16		TBD	Call TI	Call TI	0 to 70	SA32A	
AM26LS32ACPWR	ACTIVE	TSSOP	PW	16	2000	RoHS & Green	NIPDAU	Level-1-260C-UNLIM	0 to 70	SA32A	Samples

Orderable Device	Status (1)	Package Type	Package Drawing	Pins	Package Qty	Eco Plan (2)	Lead finish/ Ball material (6)	MSL Peak Temp (3)	Op Temp (°C)	Device Marking (4/5)	Samples
AM26LS32ACPWRE4	ACTIVE	TSSOP	PW	16	2000	RoHS & Green	NIPDAU	Level-1-260C-UNLIM	0 to 70	SA32A	Samples
AM26LS32AID	OBSOLETE	SOIC	D	16		TBD	Call TI	Call TI	-40 to 85	26LS32AI	
AM26LS32AIDR	ACTIVE	SOIC	D	16	2500	RoHS & Green	NIPDAU	Level-1-260C-UNLIM	-40 to 85	26LS32AI	Samples
AM26LS32AIDRG4	ACTIVE	SOIC	D	16	2500	RoHS & Green	NIPDAU	Level-1-260C-UNLIM	-40 to 85	26LS32AI	Samples
AM26LS32AIN	ACTIVE	PDIP	N	16	25	RoHS & Green	NIPDAU	N / A for Pkg Type	-40 to 85	AM26LS32AIN	Samples
AM26LS32AMFKB	ACTIVE	LCCC	FK	20	55	Non-RoHS & Green	SNPB	N / A for Pkg Type	-55 to 125	5962- 7802003M2A AM26LS 32AMFKB	Samples
AM26LS32AMJ	ACTIVE	CDIP	J	16	25	Non-RoHS & Green	SNPB	N / A for Pkg Type	-55 to 125	AM26LS32AMJ	Samples
AM26LS32AMJB	ACTIVE	CDIP	J	16	25	Non-RoHS & Green	SNPB	N / A for Pkg Type	-55 to 125	5962-7802003ME A AM26LS32AMJB	Samples
AM26LS32AMWB	ACTIVE	CFP	W	16	25	Non-RoHS & Green	SNPB	N / A for Pkg Type	-55 to 125	5962-7802003MF A AM26LS32AMWB	Samples
AM26LS33ACD	OBSOLETE	SOIC	D	16		TBD	Call TI	Call TI	0 to 70	26LS33AC	
AM26LS33ACDR	ACTIVE	SOIC	D	16	2500	RoHS & Green	NIPDAU	Level-1-260C-UNLIM	0 to 70	26LS33AC	Samples
AM26LS33ACN	ACTIVE	PDIP	N	16	25	RoHS & Green	NIPDAU	N / A for Pkg Type	0 to 70	AM26LS33ACN	Samples
AM26LS33AMFKB	ACTIVE	LCCC	FK	20	55	Non-RoHS & Green	SNPB	N / A for Pkg Type	-55 to 125	5962- 7802004M2A AM26LS 33AMFKB	Samples
AM26LS33AMJ	ACTIVE	CDIP	J	16	25	Non-RoHS & Green	SNPB	N / A for Pkg Type	-55 to 125	AM26LS33AMJ	Samples
AM26LS33AMJB	ACTIVE	CDIP	J	16	25	Non-RoHS & Green	SNPB	N / A for Pkg Type	-55 to 125	5962-7802004ME A AM26LS33AMJB	Samples
AM26LS33AMWB	ACTIVE	CFP	W	16	25	Non-RoHS & Green	SNPB	N / A for Pkg Type	-55 to 125	5962-7802004MF A AM26LS33AMWB	Samples

(1) The marketing status values are defined as follows:

ACTIVE: Product device recommended for new designs.

LIFEBUY: TI has announced that the device will be discontinued, and a lifetime-buy period is in effect.

NRND: Not recommended for new designs. Device is in production to support existing customers, but TI does not recommend using this part in a new design.

PREVIEW: Device has been announced but is not in production. Samples may or may not be available.

OBSOLETE: TI has discontinued the production of the device.

(2) **RoHS:** TI defines "RoHS" to mean semiconductor products that are compliant with the current EU RoHS requirements for all 10 RoHS substances, including the requirement that RoHS substance do not exceed 0.1% by weight in homogeneous materials. Where designed to be soldered at high temperatures, "RoHS" products are suitable for use in specified lead-free processes. TI may reference these types of products as "Pb-Free".

RoHS Exempt: TI defines "RoHS Exempt" to mean products that contain lead but are compliant with EU RoHS pursuant to a specific EU RoHS exemption.

Green: TI defines "Green" to mean the content of Chlorine (Cl) and Bromine (Br) based flame retardants meet JS709B low halogen requirements of ≤ 1000 ppm threshold. Antimony trioxide based flame retardants must also meet the ≤ 1000 ppm threshold requirement.

(3) MSL, Peak Temp. - The Moisture Sensitivity Level rating according to the JEDEC industry standard classifications, and peak solder temperature.

(4) There may be additional marking, which relates to the logo, the lot trace code information, or the environmental category on the device.

(5) Multiple Device Markings will be inside parentheses. Only one Device Marking contained in parentheses and separated by a "~" will appear on a device. If a line is indented then it is a continuation of the previous line and the two combined represent the entire Device Marking for that device.

(6) Lead finish/Ball material - Orderable Devices may have multiple material finish options. Finish options are separated by a vertical ruled line. Lead finish/Ball material values may wrap to two lines if the finish value exceeds the maximum column width.

Important Information and Disclaimer:The information provided on this page represents TI's knowledge and belief as of the date that it is provided. TI bases its knowledge and belief on information provided by third parties, and makes no representation or warranty as to the accuracy of such information. Efforts are underway to better integrate information from third parties. TI has taken and continues to take reasonable steps to provide representative and accurate information but may not have conducted destructive testing or chemical analysis on incoming materials and chemicals. TI and TI suppliers consider certain information to be proprietary, and thus CAS numbers and other limited information may not be available for release.

In no event shall TI's liability arising out of such information exceed the total purchase price of the TI part(s) at issue in this document sold by TI to Customer on an annual basis.

OTHER QUALIFIED VERSIONS OF AM26LS32A, AM26LS32AM, AM26LS33A, AM26LS33AM :

● Catalog : [AM26LS32A](#), [AM26LS33A](#)

● Military : [AM26LS32AM](#), [AM26LS33AM](#)

● Space : [AM26LS33A-SP](#), [AM26LS33A-SP](#)

NOTE: Qualified Version Definitions:

- Catalog - TI's standard catalog product
- Military - QML certified for Military and Defense Applications
- Space - Radiation tolerant, ceramic packaging and qualified for use in Space-based application

TAPE AND REEL INFORMATION

QUADRANT ASSIGNMENTS FOR PIN 1 ORIENTATION IN TAPE

*All dimensions are nominal

Device	Package Type	Package Drawing	Pins	SPQ	Reel Diameter (mm)	Reel Width W1 (mm)	A0 (mm)	B0 (mm)	K0 (mm)	P1 (mm)	W (mm)	Pin1 Quadrant
AM26LS32ACDR	SOIC	D	16	2500	330.0	16.4	6.5	10.3	2.1	8.0	16.0	Q1
AM26LS32ACDR	SOIC	D	16	2500	330.0	16.4	6.5	10.3	2.1	8.0	16.0	Q1
AM26LS32ACDR	SOIC	D	16	2500	330.0	16.4	6.5	10.3	2.1	8.0	16.0	Q1
AM26LS32ACNSR	SO	NS	16	2000	330.0	16.4	8.2	10.5	2.5	12.0	16.0	Q1
AM26LS32ACNSR	SO	NS	16	2000	330.0	16.4	8.2	10.5	2.5	12.0	16.0	Q1
AM26LS32ACPWR	TSSOP	PW	16	2000	330.0	12.4	6.9	5.6	1.6	8.0	12.0	Q1
AM26LS32ACPWR	TSSOP	PW	16	2000	330.0	12.4	6.9	5.6	1.6	8.0	12.0	Q1
AM26LS32AIDR	SOIC	D	16	2500	330.0	16.4	6.5	10.3	2.1	8.0	16.0	Q1
AM26LS33ACDR	SOIC	D	16	2500	330.0	16.4	6.5	10.3	2.1	8.0	16.0	Q1

TAPE AND REEL BOX DIMENSIONS

*All dimensions are nominal

Device	Package Type	Package Drawing	Pins	SPQ	Length (mm)	Width (mm)	Height (mm)
AM26LS32ACDR	SOIC	D	16	2500	340.5	336.1	32.0
AM26LS32ACDR	SOIC	D	16	2500	356.0	356.0	35.0
AM26LS32ACDR	SOIC	D	16	2500	353.0	353.0	32.0
AM26LS32ACNSR	SO	NS	16	2000	367.0	367.0	38.0
AM26LS32ACNSR	SO	NS	16	2000	353.0	353.0	32.0
AM26LS32ACPWR	TSSOP	PW	16	2000	367.0	367.0	35.0
AM26LS32ACPWR	TSSOP	PW	16	2000	353.0	353.0	32.0
AM26LS32AIDR	SOIC	D	16	2500	353.0	353.0	32.0
AM26LS33ACDR	SOIC	D	16	2500	353.0	353.0	32.0

TUBE

*All dimensions are nominal

Device	Package Name	Package Type	Pins	SPQ	L (mm)	W (mm)	T (µm)	B (mm)
5962-7802003M2A	FK	LCCC	20	55	506.98	12.06	2030	NA
5962-7802003MFA	W	CFP	16	25	506.98	26.16	6220	NA
5962-7802004M2A	FK	LCCC	20	55	506.98	12.06	2030	NA
5962-7802004MFA	W	CFP	16	25	506.98	26.16	6220	NA
AM26LS32ACD	D	SOIC	16	40	507	8	3940	4.32
AM26LS32ACD	D	SOIC	16	40	506.6	8	3940	4.32
AM26LS32ACDE4	D	SOIC	16	40	506.6	8	3940	4.32
AM26LS32ACDE4	D	SOIC	16	40	507	8	3940	4.32
AM26LS32ACDG4	D	SOIC	16	40	507	8	3940	4.32
AM26LS32ACDG4	D	SOIC	16	40	506.6	8	3940	4.32
AM26LS32ACN	N	PDIP	16	25	506	13.97	11230	4.32
AM26LS32ACPW	PW	TSSOP	16	90	530	10.2	3600	3.5
AM26LS32AID	D	SOIC	16	40	507	8	3940	4.32
AM26LS32AIDE4	D	SOIC	16	40	507	8	3940	4.32
AM26LS32AIDG4	D	SOIC	16	40	507	8	3940	4.32
AM26LS32AIN	N	PDIP	16	25	506	13.97	11230	4.32
AM26LS32AMFKB	FK	LCCC	20	55	506.98	12.06	2030	NA
AM26LS32AMWB	W	CFP	16	25	506.98	26.16	6220	NA
AM26LS33ACD	D	SOIC	16	40	507	8	3940	4.32
AM26LS33ACDG4	D	SOIC	16	40	507	8	3940	4.32
AM26LS33ACN	N	PDIP	16	25	506	13.97	11230	4.32
AM26LS33AMFKB	FK	LCCC	20	55	506.98	12.06	2030	NA
AM26LS33AMWB	W	CFP	16	25	506.98	26.16	6220	NA



PACKAGE OUTLINE

NS0016A

SOP - 2.00 mm max height

SOP



4220735/A 12/2021

NOTES:

1. All linear dimensions are in millimeters. Dimensions in parenthesis are for reference only. Dimensioning and tolerancing per ASME Y14.5M.
2. This drawing is subject to change without notice.
3. This dimension does not include mold flash, protrusions, or gate burrs. Mold flash, protrusions, or gate burrs shall not exceed 0.15 mm, per side.
4. This dimension does not include interlead flash. Interlead flash shall not exceed 0.25 mm, per side.

EXAMPLE BOARD LAYOUT

NS0016A

SOP - 2.00 mm max height

SOP



SOLDER MASK DETAILS

4220735/A 12/2021

NOTES: (continued)

- 5. Publication IPC-7351 may have alternate designs.
- 6. Solder mask tolerances between and around signal pads can vary based on board fabrication site.

EXAMPLE STENCIL DESIGN

NS0016A

SOP - 2.00 mm max height

SOP



SOLDER PASTE EXAMPLE
BASED ON 0.125 mm THICK STENCIL
SCALE:7X

4220735/A 12/2021

NOTES: (continued)



7. Laser cutting apertures with trapezoidal walls and rounded corners may offer better paste release. IPC-7525 may have alternate design recommendations.
8. Board assembly site may have different recommendations for stencil design.

D (R-PDSO-G16)

PLASTIC SMALL OUTLINE



4040047-6/M 06/11

- NOTES:
- A. All linear dimensions are in inches (millimeters).
 - B. This drawing is subject to change without notice.
 -  C. Body length does not include mold flash, protrusions, or gate burrs. Mold flash, protrusions, or gate burrs shall not exceed 0.006 (0,15) each side.
 -  D. Body width does not include interlead flash. Interlead flash shall not exceed 0.017 (0,43) each side.
 - E. Reference JEDEC MS-012 variation AC.



4220204/A 02/2017

NOTES:

1. All linear dimensions are in millimeters. Any dimensions in parenthesis are for reference only. Dimensioning and tolerancing per ASME Y14.5M.
2. This drawing is subject to change without notice.
3. This dimension does not include mold flash, protrusions, or gate burrs. Mold flash, protrusions, or gate burrs shall not exceed 0.15 mm per side.
4. This dimension does not include interlead flash. Interlead flash shall not exceed 0.25 mm per side.
5. Reference JEDEC registration MO-153.

EXAMPLE BOARD LAYOUT

PW0016A

TSSOP - 1.2 mm max height

SMALL OUTLINE PACKAGE



LAND PATTERN EXAMPLE
EXPOSED METAL SHOWN
SCALE: 10X



SOLDER MASK DETAILS

4220204/A 02/2017

NOTES: (continued)

- 6. Publication IPC-7351 may have alternate designs.
- 7. Solder mask tolerances between and around signal pads can vary based on board fabrication site.

EXAMPLE STENCIL DESIGN

PW0016A

TSSOP - 1.2 mm max height

SMALL OUTLINE PACKAGE



SOLDER PASTE EXAMPLE
BASED ON 0.125 mm THICK STENCIL
SCALE: 10X

4220204/A 02/2017

NOTES: (continued)

8. Laser cutting apertures with trapezoidal walls and rounded corners may offer better paste release. IPC-7525 may have alternate design recommendations.
9. Board assembly site may have different recommendations for stencil design.

MECHANICAL DATA

NS (R-PDSO-G**)

PLASTIC SMALL-OUTLINE PACKAGE

14-PINS SHOWN



- NOTES:
- A. All linear dimensions are in millimeters.
 - B. This drawing is subject to change without notice.
 - C. Body dimensions do not include mold flash or protrusion, not to exceed 0,15.

W (R-GDFP-F16)

CERAMIC DUAL FLATPACK



- NOTES:
- A. All linear dimensions are in inches (millimeters).
 - B. This drawing is subject to change without notice.
 - C. This package can be hermetically sealed with a ceramic lid using glass frit.
 - D. Index point is provided on cap for terminal identification only.
 - E. Falls within MIL STD 1835 GDFP2-F16

GENERIC PACKAGE VIEW

FK 20

LCCC - 2.03 mm max height

8.89 x 8.89, 1.27 mm pitch

LEADLESS CERAMIC CHIP CARRIER

This image is a representation of the package family, actual package may vary.
Refer to the product data sheet for package details.



4229370VA\

J (R-GDIP-T**)

14 LEADS SHOWN

CERAMIC DUAL IN-LINE PACKAGE



DIM \ PINS **	14	16	18	20
A	0.300 (7,62) BSC	0.300 (7,62) BSC	0.300 (7,62) BSC	0.300 (7,62) BSC
B MAX	0.785 (19,94)	.840 (21,34)	0.960 (24,38)	1.060 (26,92)
B MIN	—	—	—	—
C MAX	0.300 (7,62)	0.300 (7,62)	0.310 (7,87)	0.300 (7,62)
C MIN	0.245 (6,22)	0.245 (6,22)	0.220 (5,59)	0.245 (6,22)



4040083/F 03/03

- NOTES:
- All linear dimensions are in inches (millimeters).
 - This drawing is subject to change without notice.
 - This package is hermetically sealed with a ceramic lid using glass frit.
 - Index point is provided on cap for terminal identification only on press ceramic glass frit seal only.
 - Falls within MIL STD 1835 GDIP1-T14, GDIP1-T16, GDIP1-T18 and GDIP1-T20.

N (R-PDIP-T**)

PLASTIC DUAL-IN-LINE PACKAGE

16 PINS SHOWN



- NOTES:
- A. All linear dimensions are in inches (millimeters).
 - B. This drawing is subject to change without notice.
 - Falls within JEDEC MS-001, except 18 and 20 pin minimum body length (Dim A).
 - The 20 pin end lead shoulder width is a vendor option, either half or full width.

重要声明和免责声明

TI“按原样”提供技术和可靠性数据（包括数据表）、设计资源（包括参考设计）、应用或其他设计建议、网络工具、安全信息和其他资源，不保证没有瑕疵且不做任何明示或暗示的担保，包括但不限于对适销性、某特定用途方面的适用性或不侵犯任何第三方知识产权的暗示担保。

这些资源可供使用 TI 产品进行设计的熟练开发人员使用。您将自行承担以下全部责任：(1) 针对您的应用选择合适的 TI 产品，(2) 设计、验证并测试您的应用，(3) 确保您的应用满足相应标准以及任何其他功能安全、信息安全、监管或其他要求。

这些资源如有变更，恕不另行通知。TI 授权您仅可将这些资源用于研发本资源所述的 TI 产品的应用。严禁对这些资源进行其他复制或展示。您无权使用任何其他 TI 知识产权或任何第三方知识产权。您应全额赔偿因在这些资源的使用中对 TI 及其代表造成的任何索赔、损害、成本、损失和债务，TI 对此概不负责。

TI 提供的产品受 [TI 的销售条款](#) 或 [ti.com](#) 上其他适用条款/TI 产品随附的其他适用条款的约束。TI 提供这些资源并不会扩展或以其他方式更改 TI 针对 TI 产品发布的适用的担保或担保免责声明。

TI 反对并拒绝您可能提出的任何其他或不同的条款。

邮寄地址：Texas Instruments, Post Office Box 655303, Dallas, Texas 75265
Copyright © 2024，德州仪器 (TI) 公司