

## DS90UB940-Q1 1080p FPD-Link III 至 CSI-2 解串器

### 1 特性

- 支持高达 170MHz 的像素时钟频率，支持 WUXGA (1920x1200) 和 1080p60 分辨率 (24 位色深)
- 具有偏移补偿能力的单通道或双通道 FPD-Link III 接口
- MIPI D-PHY/CSI-2 发送器
  - 支持 2 通道或 4 通道两种可选操作的 CSI-2 输出端口
  - 每个 CSI-2 端口最多支持 4 个数据通道，每个通道最高 1.3Gbps
  - 视频格式：RGB888/666/565、YUV422/420 和 RAW8/10/12
  - 可编程虚拟通道标识符
- 速度高达 2.0Mbps 的通用输入输出 (GPIO)
- 具有自动温度和老化补偿功能，支持长达 15 米的电缆
- 速率高达 3.3Mbps 的串行外设接口 (SPI) 控制接口
- 具有 1Mbps 快速模式+ 的 I<sup>2</sup>C (主/从)
- 自适应接收均衡
- 支持多条 I2S (4 个数据) 通道
- 向后兼容 DS90UB925/925AQ-Q1 和 DS90UB927Q-Q1 FPD-Link III 串行器
- 汽车应用级产品：符合 AEC-Q100 2 级要求

### 2 应用

- 汽车信息娱乐：
  - 中央信息显示屏
  - 后座娱乐系统
  - 数字仪表盘
- 高级驾驶员辅助系统 (ADAS) 摄像机系统

### 4 应用图

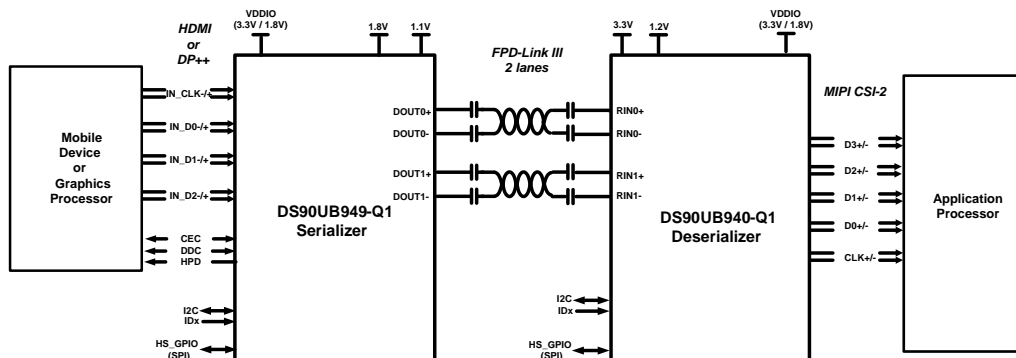

### 3 说明

DS90UB940-Q1 是一款 FPD-Link III 解串器，与 DS90UB949/947/929-Q1 串行器配合使用时可将单通道或双通道 FPD-Link III 流转换成 MIPI CSI-2 接口格式。该解串器能够在经济高效的 50Ω 单端同轴或 100Ω 差分屏蔽双绞线 (STP) 电缆上运行。它能够从单通道或双通道 FPD-Link III 串行流中恢复数据，然后将其转换为摄像机串行接口 (CSI-2) 格式，最高可支持 WUXGA 和 1080p60 视频分辨率 (24 位色深)。

FPD-Link III 接口支持通过同一条差分链路进行视频和音频数据传输以及全双工控制 (包括 I<sup>2</sup>C 和 SPI 通信)。通过两个差分对实现视频数据和控制的整合可减小互连线尺寸和重量，并简化了系统设计。通过使用低压差分信令、数据换序和随机生成最大限度地减少了电磁干扰 (EMI)。在向后兼容模式下，该器件在单一差分链路上最高可支持 WXGA 和 720p 分辨率 (24 位色深)。

该器件将自动检测 FPD-Link III 通道并提供一种时钟对齐和偏移补偿功能，无需任何特殊的训练模式。这可在互连线路 (例如，印刷电路板 (PCB) 布线) 中出现不匹配问题、电缆线对长度存在差异以及连接器不平衡时确保相位偏移在容差范围内。

#### 器件信息(1)

器件型号	封装	封装尺寸 (标称值)
DS90UB940-Q1	超薄四方扁平无引线 (WQFN) NKD (64)	9.00mm x 9.00mm

(1) 如需了解所有可用封装，请见数据表末尾的可订购产品附录。



## 目录

1 特性 .....	1	8.2 Functional Block Diagram .....	24
2 应用 .....	1	8.3 Feature Description .....	25
3 说明 .....	1	8.4 Device Functional Modes .....	36
4 应用图 .....	1	8.5 Programming .....	43
5 修订历史记录 .....	2	8.6 Register Maps .....	46
6 Pin Configurations and Functions .....	4	9 Application and Implementation .....	67
7 Specifications .....	9	9.1 Application Information .....	67
7.1 Absolute Maximum Ratings .....	9	9.2 Typical Applications .....	67
7.2 ESD Ratings—JEDEC .....	9	10 Power Supply Recommendations .....	72
7.3 ESD Ratings—IEC and ISO .....	9	10.1 Power Up Requirements and PDB Pin .....	72
7.4 Recommended Operating Conditions .....	9	11 Layout .....	72
7.5 Thermal Information .....	10	11.1 Layout Guidelines .....	72
7.6 DC Electrical Characteristics .....	10	11.2 Layout Example .....	74
7.7 AC Electrical Characteristics .....	13	12 器件和文档支持 .....	76
7.8 Timing Requirements for the Serial Control Bus .....	14	12.1 文档支持 .....	76
7.9 Switching Characteristics .....	15	12.2 社区资源 .....	76
7.10 Timing Diagrams and Test Circuits .....	17	12.3 商标 .....	76
7.11 Power Sequence .....	22	12.4 静电放电警告 .....	76
7.12 Typical Characteristics .....	23	12.5 Glossary .....	76
8 Detailed Description .....	24	13 机械、封装和可订购信息 .....	76
8.1 Overview .....	24		

## 5 修订历史记录

注：之前版本的页码可能与当前版本有所不同。

Changes from Original (November 2014) to Revision A	Page
• Added shared pins description on SPI pins .....	5
• Added shared pins description on GPIO pins .....	6
• Added shared pins description on D_GPIO pins .....	6
• Added shared pins description on register only GPIO pins. Changed "Local register control only" to "I2C register control only" .....	6
• Added shared pins description on slave mode I2S pins .....	7
• Added shared pins description on master mode I2S pins .....	7
• Added legend on I/O TYPE .....	8
• Moved Storage Temperature Range from ESD to Absolute Maximum Ratings table .....	9
• Added ESD Ratings table .....	9
• Changed IDD12Z limit from 11mA to 30mA per PE re-characterization .....	12
• Changed Fast Plus Mode $t_{SP}$ maximum from 20ns to 50ns .....	14
• Added Power Sequence section .....	22
• Deleted MODE, CSI LANE, REPLICATE columns in MODE_SEL0 table .....	39
• Deleted MODE column. Added (CSI PORT) to CSI_SEL column in MODE_SEL1 table .....	39
• Changed default value from "0" to "1" in register 0x01[2] .....	46
• Added description to register 0x01[1] "Registers which are loaded by pin strap will be restored to their original strap value when this bit is set. These registers show 'Strap' as their default value in this table." .....	46
• Added to 0x02[7] in Description column "A Digital reset 0x01[0] should be asserted after toggling Output Enable bit LOW to HIGH" .....	46
• Added "Loaded from remote SER" in register 0x07[7:1] function column .....	48
• Changed signal detect bit to reserved in register 0x1C[1] .....	51
• Changed "0" to "0/1" in register RW column of 0x1C[1] .....	51

## 修订历史记录 (接下页)

• Changed signal detect bit to reserved in register 0x1C[1] description .....	51
• Changed from Reserved to Rev-ID in register 0x1D Function column .....	52
• On register 0x22 added "(Loaded from remote SER)" .....	55
• Corrected in register 0x24[3] 0: Bist configured through "bit 0" to "bits 2:0" in description .....	57
• Added in register 0x24[2:1] additional description.....	57
• Changed in register 0x24[1] description to "internal" .....	57
• Changed in register 0x24[2] description to "internal" .....	57
• On register 0x28 added "Loaded from remote SER" .....	58
• Added clarification description on register 0x37 MODE_SEL .....	60
• Merged on 0x45 bits[7:4] and bits[3:0] default value: 0x08.....	61

---

## 6 Pin Configurations and Functions

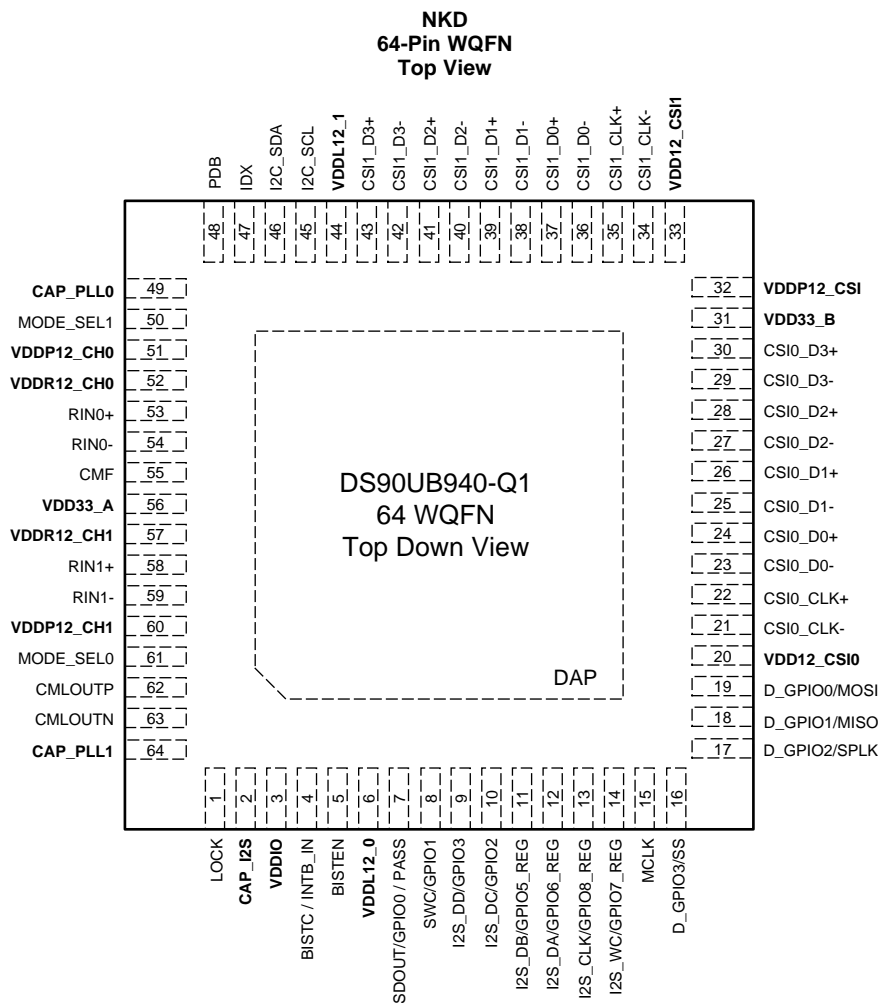

### Pin Functions

PIN		I/O, TYPE	DESCRIPTION
NAME	NUMBER		
<b>MIPI DPHY / CSI-2 OUTPUT PINS - Layout note: for unused CSI outputs, float those pins (do not connect to an external pullup or pulldown)</b>			
CSI0_CLK- CSI0_CLK+	21 22	O, DPHY	CSI0 Differential clock
CSI0_D0- CSI0_D0+	23 24	O, DPHY	CSI0 Differential pair 0
CSI0_D1- CSI0_D1+	25 26	O, DPHY	CSI0 Differential pair 1
CSI0_D2- CSI0_D2+	27 28	O, DPHY	CSI0 Differential pair 2
CSI0_D3- CSI0_D3+	29 30	O, DPHY	CSI0 Differential pair 3
CSI1_CLK- CSI1_CLK+	34 35	O, DPHY	CSI1 Differential clock
CSI1_D0- CSI1_D0+	36 37	O, DPHY	CSI1 Differential pair 1
CSI1_D1- CSI1_D1+	38 39	O, DPHY	CSI1 Differential pair 2

**Pin Functions (continued)**

PIN		I/O, TYPE	DESCRIPTION
NAME	NUMBER		
CSI1_D2- CSI1_D2+	40 41	O, DPHY	CSI1 Differential pair 3
CSI1_D3- CSI1_D3+	42 43	O, DPHY	CSI1 Differential pair 3
<b>FPD-LINK III INTERFACE - Layout note: for unused FPD-LinkIII inputs, float those pins (do not connect to an external pullup or pulldown)</b>			
RIN0-	54	I/O, CML	FPD-Link III Inverting Input/Output The output must be AC-coupled with a 33 nF capacitor.
RIN0+	53	I/O, CML	FPD-Link III True Input/Output The output must be AC-coupled with a 33 nF capacitor.
RIN1-	59	I/O, CML	FPD-Link III Inverting Input/Output The output must be AC-coupled with a 33 nF capacitor.
RIN1+	58	I/O, CML	FPD-Link III True Input/Output The output must be AC-coupled with a 33 nF capacitor.
CMF	55	I/O, CML	Common Mode Filter. Connect 0.1 μF capacitor to GND
<b>I2C PINS</b>			
I2C_SDA	46	I/O, Open-Drain	I2C Data Input / Output interface Open drain. Must have an external pull-up resistor to VDDIO <b>DO NOT FLOAT</b> . Recommended pull-up: 4.7 kΩ.
I2C_SCL	45	I/O, Open-Drain	I2C Clock Input / Output Interface Open drain. Must have an external pull-up resistor to VDDIO <b>DO NOT FLOAT</b> . Recommended pull-up: 4.7 kΩ.
IDx	47	I, Analog Configuration Pin	Analog input. I2C Serial Control Bus Device ID Address. <a href="#">Table 11</a>
<b>SPI PINS (Pin function programmed through register) - Layout note: for unused SPI pins, tie to an external pulldown</b>			
MOSI (D_GPIO0)	19	Multi-function pin I/O, LVCMOS w/ weak internal PD	Master Out, Slave In. (Pin is shared with D_GPIO0)
MISO (D_GPIO1)	18	Multi-function pin I/O, LVCMOS w/ weak internal PD	Master In, Slave Out. (Pin is shared with D_GPIO1)
SPLK (D_GPIO2)	17	Multi-function pin I/O, LVCMOS w/ weak internal PD	Serial clock. (Pin is shared with D_GPIO2)
SS (D_GPIO3)	16	Multi-function pin I/O, LVCMOS w/ weak internal PD	Slave select. (Pin is shared with D_GPIO3)
<b>CONTROL PINS</b>			
MODE_SELO	61	I, Analog Configuration Pin	Analog input. Mode Select 0. Connect to external pull-up to VDD33 and pull-down to GND to create a voltage divider. See <a href="#">Table 8</a>
MODE_SEL1	50	I, Analog Configuration Pin	Analog input. Mode Select 1. Connect to external pull-up to VDD33 and pull-down to GND to create a voltage divider. See <a href="#">Table 9</a>

**Pin Functions (continued)**

PIN		I/O, TYPE	DESCRIPTION
NAME	NUMBER		
PDB	48	I, LVCMOS Configuration Pin w/ weak internal PD	Power-Down Mode Input Pin PDB = 1, device is enabled (normal operation) PDB = 0, device is powered down. When the device is in the POWER DOWN state, the LVCMOS outputs are in tri-state, the PLL is shutdown and IDD is minimized. <b>Note: PDB pin requires minimum ramp time of 200us</b>
BISTEN	5	I, LVCMOS Configuration Pin w/ weak internal PD	Bist Enable Pin 0: BIST Mode is disabled. 1: BIST Mode is enabled. See <a href="#">Built-In Self Test (BIST)</a> for more information
BISTC (INTB_IN)	4	I, LVCMOS Configuration Pin w/ weak internal PD	Bist Clock Select. 0: PCLK 1: 33MHz (Pin is shared with INTB_IN)
INTB_IN (BISTC)	4	I, LVCMOS w/ weak internal PD	Interrupt input. (Pin is shared with BISTC)
<b>BIDIRECTIONAL CONTROL CHANNEL (BCC) GPIO PINS (default pin function) - Layout note: for unused GPIO(s), tie to an external pulldown</b>			
GPIO0 (SDOUT)	7	Multi-function pin I/O, LVCMOS	BCC GPIO0. default state: logic <i>LOW</i> (Pin is shared with SDOUT)
GPIO1 (SWC)	8	Multi-function pin I/O, LVCMOS	BCC GPIO1. default state: logic <i>LOW</i> (Pin is shared with SWC)
GPIO2 (I2S_DC)	10	Multi-function pin I/O, LVCMOS	BCC GPIO2. default state: logic <i>LOW</i> (Pin is shared with I2S_DC)
GPIO3 (I2S_DD)	9	Multi-function pin I/O, LVCMOS	BCC GPIO3. default state: logic <i>LOW</i> (Pin is shared with I2S_DD)
<b>HIGH-SPEED GPIO PINS HIGH-SPEED GPIO PINS (default pin function) - Layout note: for unused D_GPIO(s), tie to an external pulldown</b>			
D_GPIO0 (MOSI)	19	I/O, LVCMOS	General Purpose I/O in 2-lane FPD-Link III mode default state: <i>tri-state</i> (Pin is shared with MOSI)
D_GPIO1 (MISO)	18	I/O, LVCMOS	General Purpose I/O in 2-lane FPD-Link III mode default state: <i>tri-state</i> (Pin is shared with MISO)
D_GPIO2 (SPLK)	17	I/O, LVCMOS	General Purpose I/O in 2-lane FPD-Link III mode default state: <i>tri-state</i> (Pin is shared with SPLK)
D_GPIO3 (SS)	16	I/O, LVCMOS	General Purpose I/O in 2-lane FPD-Link III mode default state: <i>tri-state</i> (Pin is shared with SS)
<b>REGISTER READ/Writes ONLY GPIO PINS (default pin function) - Layout note: for unused GPIO(s), tie to an external pulldown</b>			
GPIO5_REG (I2S_DB)	11	Multi-function pin I/O, LVCMOS	General Purpose Input/Output 5 I2C register control only. default state: logic <i>LOW</i> (Pin is shared with I2S_DB)
GPIO6_REG (I2S_DA)	12	Multi-function pin I/O, LVCMOS	General Purpose Input/Output 6 I2C register control only. default state: logic <i>LOW</i> (Pin is shared with I2S_DA)

**Pin Functions (continued)**

PIN		I/O, TYPE	DESCRIPTION
NAME	NUMBER		
GPIO7_REG (I2S_WC)	14	Multi-function pin I/O, LVCMOS	General Purpose Input/Output 7 I2C register control only. default state: logic <i>LOW</i> (Pin is shared with I2S_WC)
GPIO8_REG (I2S_CLK)	13	Multi-function pin I/O, LVCMOS	General Purpose Input/Output 8 I2C register control only. default state: logic <i>LOW</i> (Pin is shared with I2S_CLK)
<b>SLAVE MODE LOCAL I2S CHANNEL PINS (Pin function programmed through register) - <i>Layout note: for unused I2S outputs, tie to an external pulldown</i></b>			
I2S_WC (GPIO7_REG)	14	Multi-function pin O, LVCMOS	Slave Mode I2S Word Clock Output. (Pin is shared with GPIO7_REG)
I2S_CLK (GPIO8_REG)	13	Multi-function pin O, LVCMOS	Slave Mode I2S Clock Output. (Pin is shared with GPIO8_REG)
I2S_DA (GPIO6_REG)	12	Multi-function pin O, LVCMOS	Slave Mode I2S Data Output. (Pin is shared with GPIO6_REG)
I2S_DB (GPIO5_REG)	11	Multi-function pin O, LVCMOS	Slave Mode I2S Data Output. (Pin is shared with GPIO5_REG)
I2S_DC (GPIO2_REG)	10	Multi-function pin O, LVCMOS	Slave Mode I2S Data Output. (Pin is shared with GPIO2)
I2S_DD (GPIO3_REG)	9	Multi-function pin O, LVCMOS	Slave Mode I2S Data Output. (Pin is shared with GPIO3)
<b>MASTER MODE LOCAL I2S CHANNEL PINS (Pin function programmed through register) - <i>Layout note: for unused GPIO(s), tie to an external pulldown</i></b>			
SWC (GPIO1)	8	Multi-function pin O, LVCMOS	Master Mode I2S Word Clock Output. (Pin is shared with GPIO1)
SDOUT (GPIO0)	7	Multi-function pin O, LVCMOS	Master Mode I2S Data Output. (Pin is shared with GPIO0)
MCLK (GPIO9)	15	Multi-function pin O, LVCMOS	Master Mode I2S System Clock Output. (Pin is shared with GPIO9)
<b>STATUS PINS - <i>Layout note: add a test point (TP) on these pins</i></b>			
LOCK	1	O, LVCMOS	Lock Status Output LOCK = 1: PLL acquired lock to the reference clock input; DPHY outputs are active LOCK = 0: PLL is unlocked
PASS	7	O, LVCMOS	Normal mode status output pin (BISTEN = 0) PASS = 1: No fault detected on input display timing PASS = 0: Indicates an error condition or corruption in display timing. Fault condition occurs: <ol style="list-style-type: none"> <li>DE length value mismatch measured once in succession</li> <li>VSync length value mismatch measured twice in succession</li> </ol> BIST mode status output pin (BISTEN = 1) PASS = 1: No error detected PASS = 0: Error detected
<b>POWER &amp; GROUND <sup>(1)</sup></b>			
VDD33_A, VDD33_B	56 31	Power	3.3V (±10%) supply. Power to on-chip regulator. Requires 10 µF, 1 µF, 0.1 µF, and 0.01 µF capacitors to GND

(1) The VDD (VDD12, VDD33, and VDDIO) supply ramp should be faster than 1.5ms with a monotonic rise

**Pin Functions (continued)**

PIN		I/O, TYPE	DESCRIPTION
NAME	NUMBER		
VDDIO	3	Power	LVC MOS I/O power supply, 1.8V (±5%) OR 3.3V (±10%). Requires 10 µF, 1 µF, 0.1 µF, and 0.01 µF capacitors to GND
VDD12_CSI0	20	Power	1.2V (±5%) supplies. Requires 10 µF, 1 µF, 0.1 µF, and 0.01 µF capacitors to GND at each VDD pin.
VDDP12_CSI	32		
VDD12_CSI1	33		
VDDL12_0	6		
VDDL12_1	44		
VDDP12_CH0	51		
VDDR12_CH0	52		
VDDP12_CH1	60		
VDDR12_CH1	57		
CAP_PLL0	49	CAP	Decoupling capacitor connection for on-chip regulator. Each requires a 0.1 µF decoupling capacitor to GND.
CAP_PLL1	64		
CAP_I2S	2		
VSS	DAP	Ground	DAP is the large metal contact at the bottom side, located at the center of the WQFN package. Connect to the ground plane (GND) with at least 32 vias.
<b>OTHER PINS</b>			
CMLOUTP	62	O, CML	Monitor point for equalized differential signal. Layout recommendation: 1) place 0.1 µF series capacitor on CMLOUTP and CMLOUTN 2) place 100ohm termination between 0.1 µF away from CMLOUTP and CMLOUTN pins 3) place test points from 0.1 µF capacitors
CMLOUTN	63		

The definitions below define the functionality of the I/O cells for each pin.

**I/O TYPE:**

- P = Power Supply
- G = Ground
- CML = CML Interface
- DPHY = MIPI DPHY Interface
- Analog = Analog Interface
- LVC MOS = LVC MOS pin; Referenced to VDDIO IO supply
- I = Input
- O = Output
- I/O = Input/Output
- PD, PU = Internal Pull-Down/Pull-Up (All strap pins have weak internal pull-ups or pull-downs. If the default strap value is needed to be changed then an external resistor should be used.)
- Multi-function pin



## 7 Specifications

### 7.1 Absolute Maximum Ratings

Over operating free-air temperature range (unless otherwise noted)<sup>(1) (2)</sup>

PARAMETER		MIN	MAX	UNIT
VDD33	Supply voltage	-0.3	4.0	V
VDD12	Supply voltage	-0.3	1.8	V
VDDIO	Supply voltage	-0.3	4.0	V
	LVC MOS I/O voltage	-0.3	VDDIO + 0.3	V
	FPD-Link III input voltage	-0.3	2.75	V
T <sub>J</sub>	Junction temperature		150	°C
T <sub>stg</sub>	Storage temperature range	-65	150	°C

- (1) Stresses beyond those listed under *Absolute Maximum Ratings* may cause permanent damage to the device. These are stress ratings only, which do not imply functional operation of the device at these or any other conditions beyond those indicated under *Recommended Operating Conditions*. Exposure to absolute-maximum-rated conditions for extended periods may affect device reliability.
- (2) For soldering specifications, see product folder at [www.ti.com](http://www.ti.com) and [SNOA549](#)

### 7.2 ESD Ratings—JEDEC

		VALUE	UNIT
V <sub>(ESD)</sub>	Electrostatic discharge	Human-body model (HBM), per AEC Q100-002 <sup>(1)</sup>	±8000
		Charged-device model (CDM), per AEC Q100-011	±1250

- (1) AEC Q100-002 indicates that HBM stressing shall be in accordance with the ANSI/ESDA/JEDEC JS-001 specification.

### 7.3 ESD Ratings—IEC and ISO

			VALUE	UNIT
V <sub>(ESD)</sub>	Electrostatic discharge	R <sub>D</sub> = 330 Ω, C <sub>S</sub> = 150 pF	IEC, powered-up only contact discharge (R <sub>IN0+</sub> , R <sub>IN0-</sub> , R <sub>IN1+</sub> , R <sub>IN1-</sub> )	±8000
			IEC, powered-up only air-gap discharge (R <sub>IN0+</sub> , R <sub>IN0-</sub> , R <sub>IN1+</sub> , R <sub>IN1-</sub> )	±15000
		R <sub>D</sub> = 330 Ω, C <sub>S</sub> = 150 and 330 pF	ISO10605 contact discharge (R <sub>IN0+</sub> , R <sub>IN0-</sub> , R <sub>IN1+</sub> , R <sub>IN1-</sub> )	±8000
			ISO10605 air-gap discharge (R <sub>IN0+</sub> , R <sub>IN0-</sub> , R <sub>IN1+</sub> , R <sub>IN1-</sub> )	±15000
		R <sub>D</sub> = 2 kΩ, C <sub>S</sub> = 150 and 330 pF	ISO10605 contact discharge (R <sub>IN0+</sub> , R <sub>IN0-</sub> , R <sub>IN1+</sub> , R <sub>IN1-</sub> )	±8000
			ISO10605 air-gap discharge (R <sub>IN0+</sub> , R <sub>IN0-</sub> , R <sub>IN1+</sub> , R <sub>IN1-</sub> )	±15000

### 7.4 Recommended Operating Conditions

	MIN	NOM	MAX	UNIT
Supply Voltage (VDD33)	3.0	3.3	3.6	V
Supply Voltage (VDD18)	1.71	1.8	1.89	V
Supply Voltage (VDD12)	1.14	1.2	1.26	V
Operating Free Air Temperature (T <sub>A</sub> )	-40	25	105	°C
Pixel Clock Frequency (Single Link)	25		96	MHz
Pixel Clock Frequency (Dual Link)	50		170	MHz
Supply Noise -- VDD33 (DC-50MHz)			100	mV <sub>p-p</sub>
Supply Noise -- VDD18 (DC-50MHz)			50	mV <sub>p-p</sub>
Supply Noise -- VDD12 (DC-50MHz)			25	mV <sub>p-p</sub>

## 7.5 Thermal Information

THERMAL METRIC <sup>(1)</sup>		DS90UB940-Q1	UNIT
		WQFN (NKD)	
		64 PINS	
R <sub>θJA</sub>	Junction-to-ambient thermal resistance	24.8	°C/W
R <sub>θJC(top)</sub>	Junction-to-case (top) thermal resistance	6.2	
R <sub>θJB</sub>	Junction-to-board thermal resistance	3.6	
ψ <sub>JT</sub>	Junction-to-top characterization parameter	0.1	
ψ <sub>JB</sub>	Junction-to-board characterization parameter	3.6	
R <sub>θJC(bot)</sub>	Junction-to-case (bottom) thermal resistance	0.6	

(1) For more information about traditional and new thermal metrics, see the *IC Package Thermal Metrics* application report, [SPRA953](#).

## 7.6 DC Electrical Characteristics

Over recommended operating supply and temperature ranges unless otherwise specified.

PARAMETER		TEST CONDITIONS	PIN/FREQ.	MIN	TYP	MAX	UNIT
<b>3.3V LVCMOS I/O (VDDIO = 3.3V ± 10%)</b>							
V <sub>IH</sub>	High Level Input Voltage		PDB, BISTEN, BISTC, GPIO[3:0], D_GPIO[3:0],	2.0		VDDIO	V
V <sub>IL</sub>	Low Level Input Voltage			0		0.8	V
I <sub>IN</sub>	Input Current	V <sub>IN</sub> = 0V or VDDIO	I2S_DA, I2S_DB, I2S_DC, I2S_DD, I2S_CLK, I2S_WC, LOCK, PASS	-10		10	μA
V <sub>OH</sub>	High Level Output Voltage	I <sub>OH</sub> = -4mA		2.4		VDDIO	V
V <sub>OL</sub>	Low Level Output Voltage	I <sub>OL</sub> = +4mA		0		0.4	V
I <sub>OS</sub>	Output Short Circuit Current	V <sub>OUT</sub> = 0V			-55		mA
I <sub>OZ</sub>	Tri-state Output Current	PDB = 0V V <sub>OUT</sub> = 0V or VDDIO		-20		20	μA
C <sub>IN</sub>	Input Capacitance					10	pF
<b>1.8V LVCMOS I/O (VDDIO = 1.8V ± 5%)</b>							
V <sub>IH</sub>	High Level Input Voltage		PDB, BISTEN, BISTC, GPIO[3:0], D_GPIO[3:0],	0.65 * VDDIO		VDDIO	V
V <sub>IL</sub>	Low Level Input Voltage			0		0.35 * VDDIO	V
I <sub>IN</sub>	Input Current	V <sub>IN</sub> = 0V or VDDIO	I2S_DA, I2S_DB, I2S_DC, I2S_DD, I2S_CLK, I2S_WC, LOCK, PASS	-10		10	μA
V <sub>OH</sub>	High Level Output Voltage	I <sub>OH</sub> = -4mA		VDDIO- 0.45		VDDIO	V
V <sub>OL</sub>	Low Level Output Voltage	I <sub>OL</sub> = +4mA		0		0.45	V
I <sub>OS</sub>	Output Short Circuit Current	V <sub>OUT</sub> = 0V			-35		mA
I <sub>OZ</sub>	Tri-state Output Current	PDB = 0V V <sub>OUT</sub> = 0V or VDDIO		-20		20	μA
C <sub>IN</sub>	Input Capacitance					10	pF
<b>SERIAL CONTROL BUS (VDDIO = 1.8V ± 5% OR 3.3V ± 10%)</b>							
V <sub>IH</sub>	Input High Level		I2C_SDA, I2C_SCL	0.7 * VDDIO		VDD33	V
V <sub>IL</sub>	Input Low Level			GND		0.3 * VDDIO	V
V <sub>HY</sub>	Input Hysteresis				>50		mV
V <sub>OL</sub>	Output Low Level	I <sub>OL</sub> = +4mA		0		0.4	V
I <sub>IN</sub>	Input Current	V <sub>IN</sub> = 0V or VDDIO		-10		10	μA

## DC Electrical Characteristics (continued)

Over recommended operating supply and temperature ranges unless otherwise specified.

PARAMETER		TEST CONDITIONS	PIN/FREQ.	MIN	TYP	MAX	UNIT	
<b>FPD-LINK III CML INPUT</b>								
$V_{TH}$	Differential Threshold High Voltage	$V_{CM} = 2.1V$ (Internal $V_{BIAS}$ )	RIN0+, RIN0- RIN1+, RIN1-			50	mV	
$V_{TL}$	Differential Threshold Low Voltage					-50	mV	
$V_{ID}$	Input Differential Threshold					100	mV	
$V_{CM}$	Differential Common-mode Voltage					2.1	V	
$R_T$	Internal Termination Resistor - Differential					80	100	120
<b>HSTX DRIVER</b>								
$V_{CMTX}$	HS transmit static common-mode voltage		CS10_D3±, CS10_D2±, CS10_D1±, CS10_D0±, CS10_CLK±, CS11_D3±, CS11_D2±, CS11_D1±, CS11_D0±, CS11_CLK±	150	200	250	mV	
$ \Delta V_{CMTX(1,0)} $	$V_{CMTX}$ mismatch when output is 1 or 0					5	mV <sub>P-P</sub>	
$ V_{OD} $	HS transmit differential voltage				140	200	270	mV
$ \Delta V_{OD} $	$V_{OD}$ mismatch when output is 1 or 0						14	mV
$V_{OHHS}$	HS output high voltage						360	mV
$Z_{OS}$	Single-ended output impedance				40	50	62.5	$\Omega$
$\Delta Z_{OS}$	Mismatch in single-ended output impedance						10	%
<b>LPTX DRIVER</b>								
$V_{OH}$	High Level Output Voltage	$I_{OH} = -4mA$	CS10_D3±, CS10_D2±, CS10_D1±, CS10_D0±, CS10_CLK±, CS11_D3±, CS11_D2±, CS11_D1±, CS11_D0±, CS11_CLK±	1.05	1.2	1.3	V	
$V_{OL}$	Low Level Output Voltage	$I_{OL} = +4mA$			-50		50	mV
$Z_{OLP}$	Output impedance				110			$\Omega$
<b>LOOP-THROUGH MONITOR OUTPUT</b>								
$V_{ODP-P}$	Differential Output Voltage	$R_L = 100\Omega$	CMLOUTP, CMLOUTN		360		mV	
<b>SUPPLY CURRENT</b>								
$P_T$	Total Power Consumption, Normal Operation	Checkerboard Pattern, 170MHz. See <a href="#">Figure 1</a> . 2-lane FPD-Link III Input, 2 MIPI lanes Output	VDD		628	875	mW	
$P_Z$	Total Power Consumption, Power-Down Mode	PDB = 0V			10	45	mW	
IDD12	Supply Current, Normal Operation	Checkerboard Pattern, 96MHz. See <a href="#">Figure 1</a> . 1-lane FPD-Link III Input, 2 MIPI lanes Output	VDD12 = 1.2 V		150	250	mA	
IDD33			VDD33 = 3.6 V		90	122	mA	
IDDIO			VDDIO = 1.89 V		1	6	mA	
			VDDIO = 3.6 V		1	6	mA	
IDD12	Supply Current, Normal Operation	Checkerboard Pattern, 96MHz. See <a href="#">Figure 1</a> . 1-lane FPD-Link III Input, 4 MIPI lanes Output	VDD12 = 1.2 V		125	225	mA	
IDD33			VDD33 = 3.6 V		90	122	mA	
IDDIO			VDDIO = 1.89 V		1	6	mA	
			VDDIO = 3.6 V		1	6	mA	

## DC Electrical Characteristics (continued)

Over recommended operating supply and temperature ranges unless otherwise specified.

PARAMETER		TEST CONDITIONS	PIN/FREQ.	MIN	TYP	MAX	UNIT
IDD12	Supply Current, Normal Operation	Checkerboard Pattern, 170MHz. See <a href="#">Figure 1</a> . 2-lane FPD-Link III Input, 2 MIPI lanes Output	VDD12 = 1.2 V		250	345	mA
IDD33			VDD33 = 3.6 V		90	122	mA
IDDIO			VDDIO = 1.89 V		1	6	mA
			VDDIO = 3.6 V		1	6	mA
IDD12	Supply Current, Normal Operation	Checkerboard Pattern, 170MHz. See <a href="#">Figure 1</a> . 2-lane FPD-Link III Input, 4 MIPI lanes Output	VDD12 = 1.2 V		220	300	mA
IDD33			VDD33 = 3.6 V		90	122	mA
IDDIO			VDDIO = 1.89 V		1	6	mA
			VDDIO = 3.6 V		1	6	mA
IDD12Z	Supply Current, Power Down Mode	PDB = 0 V	VDD12 = 1.2 V		2	30	mA
IDD33Z			VDD33 = 3.6 V		2	8	mA
IDDIOZ			VDDIO = 1.89 V		0.1	0.3	mA
			VDDIO = 3.6 V		0.1	0.3	mA

## 7.7 AC Electrical Characteristics

Over recommended operating supply and temperature ranges unless otherwise specified.

PARAMETER	TEST CONDITIONS	PIN/FREQ.	MIN	TYP	MAX	UNIT
<b>GPIO BIT RATE</b>						
R <sub>b,FC</sub>	Forward Channel Bit Rate	PCLK = 25MHz - 170MHz <sup>(1)</sup>	GPIO[3:0]		0.25 * PCLK	Mbps
R <sub>b,BC</sub>	Back Channel Bit Rate				133	kbps
R <sub>b,BC</sub>	Back Channel Bit Rate	High Speed (2-lane Mode), 1 D_GPIO active. See Table 4.	D_GPIO[3:0]		2.0	Mbps
		High Speed (2-lane Mode), 2 D_GPIO's active. See Table 4.			1.33	Mbps
		High Speed (2-lane Mode), 4 D_GPIO's active. See Table 4.			800	kbps
		Normal mode. See Table 4.			133	kbps
t <sub>GPIO,FC</sub>	GPIO Pulse Width, Forward Channel		GPIO[3:0]		>2 / PCLK <sup>(1)</sup>	s
t <sub>GPIO,BC</sub>	GPIO Pulse Width, Back Channel		GPIO[3:0]		20	μs
<b>RESET</b>						
t <sub>LRST</sub>	PDB Reset Low Pulse		PDB	2		ms
<b>LOOP-THROUGH MONITOR OUTPUT</b>						
E <sub>W</sub>	Differential Output Eye Opening Width	RL = 100Ω, Jitter frequency > PCLK <sup>(1)</sup> / 40	CMLOUTP, CMLOUTN		0.4	UI
E <sub>H</sub>	Differential Output Eye Height	See Figure 2.			>300	mV
<b>FPD-LINK III CML INPUT</b>						
t <sub>DDL</sub>	Lock Time	See Figure 4.	RIN0+, RIN0-, RIN1+, RIN1-	5	10 <sup>(2)</sup>	ms
<b>I2S TRANSMITTER</b>						
t <sub>J,I2S</sub>	Clock Output Jitter		I2S_CLK		2	ns
t <sub>I2S</sub>	I2S Clock Period <sup>(3)</sup>	See Figure 9.			>2 / PCLK <sup>(1)</sup> or >77	ns
t <sub>HC,I2S</sub>	I2S Clock High Time <sup>(3)</sup>	See Figure 9.			0.48	t <sub>I2S</sub>
t <sub>LC,I2S</sub>	I2S Clock Low Time <sup>(3)</sup>	See Figure 9.			0.48	t <sub>I2S</sub>
t <sub>SR,I2S</sub>	I2S Set-up Time	See Figure 9.	I2S_DA, I2S_DB, I2S_DC, I2S_DD		0.4	t <sub>I2S</sub>
t <sub>HR,I2S</sub>	I2S Hold Time	See Figure 9.			0.4	t <sub>I2S</sub>

(1) PCLK refers to the equivalent pixel clock frequency, which is equal to the FPD-Link III line rate / 35.

(2) This parameter is specified by characterization and is not tested in production.

(3) I2S specifications for t<sub>LC,I2S</sub> and t<sub>HC,I2S</sub> pulses must each be greater than 1 PCLK period to ensure sampling and supersedes the 0.35\*t<sub>I2S</sub> requirement. t<sub>LC,I2S</sub> and t<sub>HC,I2S</sub> must be longer than the greater of either 0.35\*t<sub>I2S</sub> or 2 \* PCLK.

## 7.8 Timing Requirements for the Serial Control Bus

Over I<sup>2</sup>C supply and temperature ranges unless otherwise specified.

PARAMETER		TEST CONDITIONS	MIN	TYP	MAX	UNIT
f <sub>SCL</sub>	SCL Clock Frequency	Standard Mode	>0		100	kHz
		Fast Mode	>0		400	kHz
		Fast Plus Mode	>0		1	MHz
t <sub>LOW</sub>	SCL Low Period	Standard Mode	4.7			μs
		Fast Mode	1.3			μs
		Fast Plus Mode	0.5			μs
t <sub>HIGH</sub>	SCL High Period	Standard Mode	4.0			μs
		Fast Mode	0.6			μs
		Fast Plus Mode	0.26			μs
t <sub>HD;STA</sub>	Hold time for a start or a repeated start condition <a href="#">Figure 8</a>	Standard Mode	4.0			μs
		Fast Mode	0.6			μs
		Fast Plus Mode	0.26			μs
t <sub>SU;STA</sub>	Set Up time for a start or a repeated start condition <a href="#">Figure 8</a>	Standard Mode	4.7			μs
		Fast Mode	0.6			μs
		Fast Plus Mode	0.26			μs
t <sub>HD;DAT</sub>	Data Hold Time <a href="#">Figure 8</a>	Standard Mode	0			μs
		Fast Mode	0			μs
		Fast Plus Mode	0			μs
t <sub>SU;DAT</sub>	Data Set Up Time <a href="#">Figure 8</a>	Standard Mode	250			ns
		Fast Mode	100			ns
		Fast Plus Mode	50			ns
t <sub>SU;STO</sub>	Set Up Time for STOP Condition <a href="#">Figure 8</a>	Standard Mode	4.0			μs
		Fast Mode	0.6			μs
		Fast Plus Mode	0.26			μs
t <sub>BUF</sub>	Bus Free Time Between STOP and START <a href="#">Figure 8</a>	Standard Mode	4.7			μs
		Fast Mode	1.3			μs
		Fast Plus Mode	0.5			μs
t <sub>r</sub>	SCL & SDA Rise Time, <a href="#">Figure 8</a>	Standard Mode			1000 <sup>(1)</sup>	ns
		Fast Mode			300 <sup>(1)</sup>	ns
		Fast Plus Mode			120 <sup>(1)</sup>	ns
t <sub>f</sub>	SCL & SDA Fall Time, <a href="#">Figure 8</a>	Standard Mode			300 <sup>(1)</sup>	ns
		Fast mode			300 <sup>(1)</sup>	ns
		Fast Plus Mode			120 <sup>(1)</sup>	ns
C <sub>b</sub>	Capacitive Load for Each Bus Line	Standard Mode			400	pF
		Fast Mode			400	pF
		Fast Plus Mode			550	pF
t <sub>SP</sub>	Input Filter	Fast Mode			50	ns
		Fast Plus Mode			50	ns

(1) Parameter is specified by bench characterization and is not tested in production.

## 7.9 Switching Characteristics

Over recommended operating supply and temperature ranges unless otherwise specified.

PARAMETER		TEST CONDITIONS	PIN/FREQ.	MIN	TYP	MAX	UNIT	
<b>HSTX DRIVER</b>								
HSTX <sub>DBR</sub>	Data bit rate <sup>(1)</sup>	MIPI 2 Lanes	CSI0_D0±	350		1344	Mbps	
		MIPI 4 Lanes	CSI0_D1±	175		1190		
f <sub>CLK</sub>	DDR Clock frequency <sup>(1)</sup>	MIPI 2 Lanes	CSI0_D2±	175		672	MHz	
		MIPI 4 Lanes	CSI0_D3±	87.5		595		
ΔV <sub>CMTX(HF)</sub>	Common mode voltage variations HF <sup>(1)</sup>	Above 450MHz	CSI1_D1± CSI1_D2±			15	mV <sub>RMS</sub>	
ΔV <sub>CMTX(LF)</sub>	Common mode voltage variations LF <sup>(1)</sup>	Between 50 and 450MHz	CSI1_D3± CSI0_CLK± CSI1_CLK±			25	mV <sub>RMS</sub>	
t <sub>RHS</sub> t <sub>FHS</sub>	20% to 80% Rise and Fall HS <sup>(1)</sup>	HS bit rates ≤ 1 Gbps (UI ≥ 1 ns)				0.3	UI	
		HS bit rates > 1 Gbps (UI < 1 ns)				0.35	UI	
		Applicable for all HS bit rates. However, to avoid excessive radiation, bit rates ≤ 1 Gbps (UI ≥ 1 ns), should not use values below 150 ps			100			ps
SDD <sub>TX</sub>	TX differential return loss <sup>(1)</sup>	f <sub>LP</sub> MAX				-18	dB	
		f <sub>H</sub>						
		f <sub>MAX</sub>				-9	dB	
<b>LPTX DRIVER</b>								
t <sub>RLP</sub>	Rise Time LP <sup>(2)</sup> (3)	15% to 85% rise time	CSI0_D0±			25	ns	
t <sub>FLP</sub>	Fall Time LP <sup>(2)</sup> (3)	15% to 85% fall time	CSI0_D1±			25	ns	
t <sub>REOT</sub>	Rise Time Post-EoT <sup>(1)</sup> (3)	30%-85% rise time	CSI0_D2± CSI0_D3±			35	ns	
t <sub>LP-PULSE-TX</sub>	Pulse width of the LP exclusive-OR clock <sup>(1)</sup> (3)	First LP exclusive-OR clock pulse after Stop state or last pulse before Stop state	CSI1_D0± CSI1_D1± CSI1_D2±	40			ns	
		All other pulses	CSI1_D3±	20			ns	
t <sub>LP-PER-TX</sub>	Period of the LP exclusive-OR clock <sup>(1)</sup>		CSI0_CLK± CSI1_CLK±	90			ns	
DV/DtSR	Slew rate <sup>(2)</sup> (3)	Load = 0pF				500	mV/ns	
		Load = 5pF				300	mV/ns	
		Load = 20pF				250	mV/ns	
		Load = 70pF				150	mV/ns	
		Load = 0 to 70pF (Falling Edge Only)			30			mV/ns
		Load = 0 to 70pF (Rising Edge Only)			30			mV/ns
		Load = 0 to 70pF (Rising Edge Only)			30 - 0.075*(V O,INST - 700)			
C <sub>LOAD</sub>	Load capacitance <sup>(3)</sup>			0		70	pF	

(1) Specification is ensured by design and is not tested in production.

(2) This parameter is specified by characterization and is not tested in production.

(3) C<sub>LOAD</sub> includes the low-frequency equivalent transmission line capacitance. The capacitance of TX and RX are assumed to always be <10 pF. The distributed line capacitance can be up to 50 pF for a transmission line with 2ns delay.

## Switching Characteristics (continued)

Over recommended operating supply and temperature ranges unless otherwise specified.

PARAMETER		TEST CONDITIONS	PIN/FREQ.	MIN	TYP	MAX	UNIT
<b>DATA-CLOCK TIMING SPECIFICATIONS <sup>(1)</sup> (Figure 10)</b>							
$U_{INST}$	UI instantaneous	$f_{CLK} = \text{CSI-2 DDR Clock frequency}$	CSI0_D0± CSI0_D1±	$1/(f_{CLK} * 2)$			UI
$\Delta UI$	UI variation PCLK = 25 - 96MHz	$UI \geq 1\text{ns}$	CSI0_D2± CSI0_D3±	-10%		10%	UI
		$UI < 1\text{ns}$	CSI1_D0±	-5%		5%	UI
$t_{SKEW(TX)}$	Data to Clock Skew (measured at transmitter) Skew between clock and data from ideal center	Data rate $\leq 1\text{ Gbps}$	CSI1_D1±	-0.15		0.15	$U_{INST}$
		Data rate $> 1\text{ Gbps}$	CSI1_D2± CSI1_D3± CSI0_CLK± CSI1_CLK±	-0.2		0.2	$U_{INST}$
<b>CSI-2 TIMING SPECIFICATIONS <sup>(1)</sup> (Figure 11, Figure 12)</b>							
$t_{CLK-MISS}$	Timeout for receiver to detect absence of Clock transitions and disable the Clock Lane HS-RX		CSI0_D0± CSI0_D1± CSI0_D2±	60			ns
$t_{CLK-POST}$	HS exit		CSI0_D3± CSI1_D0±	60 + 52*UI			ns
$t_{CLK-PRE}$	Time HS clock shall be driver prior to any associated Data Lane beginning the transition from LP to HS mode		CSI1_D1± CSI1_D2± CSI1_D3± CSI0_CLK± CSI1_CLK±	8			UI
$t_{CLK-PREPARE}$	Clock Lane HS Entry			38		95	ns
$t_{CLK-SETTLE}$	Time interval during which the HS receiver shall ignore any Clock Lane HS transitions			95		300	ns
$t_{CLK-TERM-EN}$	Time-out at Clock Lane Display Module to enable HS Termination					38	ns
$t_{CLK-TRAIL}$	Time that the transmitter drives the HS-0 state after the last payload clock bit of a HS transmission burst			60			ns
$t_{CLK-PREPARE} + t_{CLK-ZERO}$	TCLK-PREPARE + time that the transmitter drives the HS-0 state prior to starting the Clock			300			ns
$t_{D-TERM-EN}$	Time for the Data Lane receiver to enable the HS line termination					35 + 4*UI	ns
$t_{EOT}$	Transmitted time interval from the start of $t_{HS-TRAIL}$ to the start of the LP-11 state following a HS burst	see <sup>(4)</sup>				105 + 12*UI	ns
$t_{HS-EXIT}$	Time that the transmitter drives LP=11 following a HS burst			100			ns
$t_{HS-PREPARE}$	Data Lane HS Entry			40 + 4*UI		85 + 6*UI	ns

- (4) (a) 1280x720p60; PCLK = 74.25MHz; 4 MIPI lanes reg0x6c=0x02; reg0x6d=0x84  
 (b) 1280x720p60; PCLK = 74.25MHz; 2 MIPI lanes reg0x6c=0x02; reg0x6d=0x89  
 (c) 640x480p60; PCLK = 25MHz; 4 MIPI lanes reg0x6c=0x02; reg0x6d=0x82  
 (d) 640x480p60; PCLK = 25MHz; 2 MIPI lanes reg0x6c=0x02; reg0x6d=0x83  
 (e) Other video formats may require additional register configuration.



### Switching Characteristics (continued)

Over recommended operating supply and temperature ranges unless otherwise specified.

PARAMETER	TEST CONDITIONS	PIN/FREQ.	MIN	TYP	MAX	UNIT
$t_{HS-PREPARE} + t_{HS-ZERO}$	$t_{HS-PREPARE}$ + time that the transmitter drives the HS-0 state prior to transmitting the Sync sequence		145 + $10 \cdot UI$			ns
$t_{HS-SETTLE}$	Time interval during which the HS receiver shall ignore any Data Lane HS transitions, starting from the beginning of $t_{HS-SETTLE}$		85 + $6 \cdot UI$		145 + $10 \cdot UI$	ns
$t_{HS-SKIP}$	Time interval during which the HS-RX should ignore any transitions on the Data Lane, following a HS burst. The end point of the interval is defined as the beginning of the LP-11 state following the HS burst.		40		55 + $4 \cdot UI$	ns
$t_{HS-TRAIL}$	Data Lane HS Exit		60 + $4 \cdot UI$			ns
$t_{LPX}$	Transmitted length of LP state		50			ns
$t_{WAKEUP}$	Recovery Time from Ultra Low Power State (ULPS)		1			ms

### 7.10 Timing Diagrams and Test Circuits

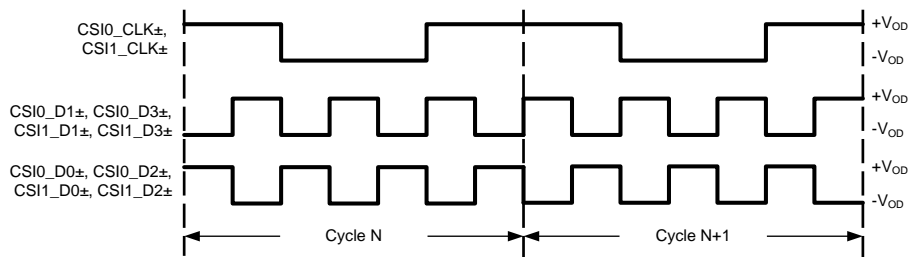

Figure 1. Checkerboard Data Pattern

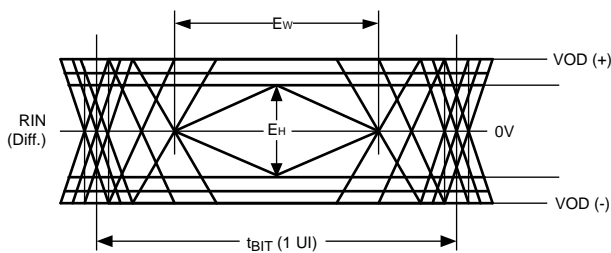

Figure 2. CML Output Driver



Figure 3. LVCMOS Transition Times

Timing Diagrams and Test Circuits (continued)

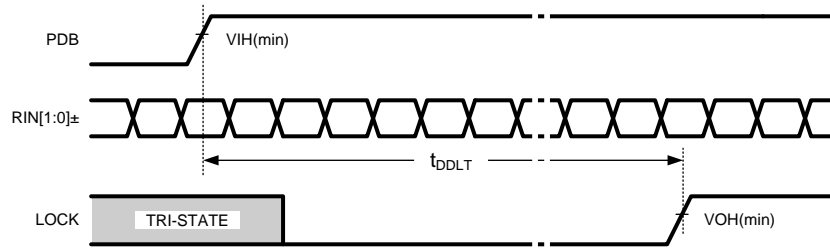

Figure 4. CML PLL Lock Time

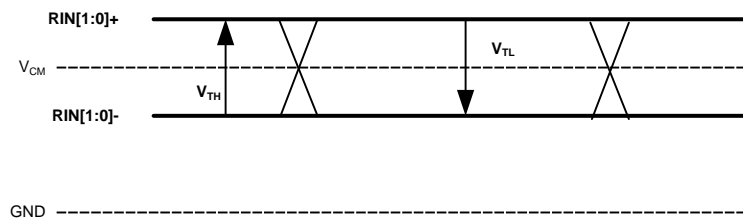

Figure 5. FPD-Link III Receiver DC  $V_{TH}/V_{TL}$  Definition

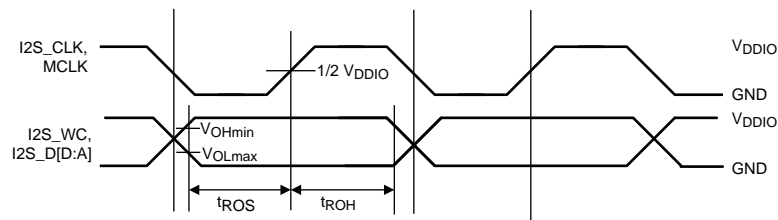

Figure 6. Output Data Valid (Setup and Hold) Times

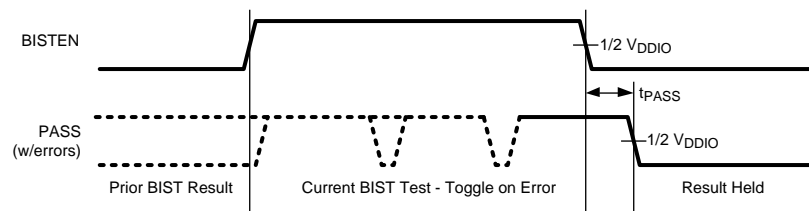

Figure 7. BIST PASS Waveform

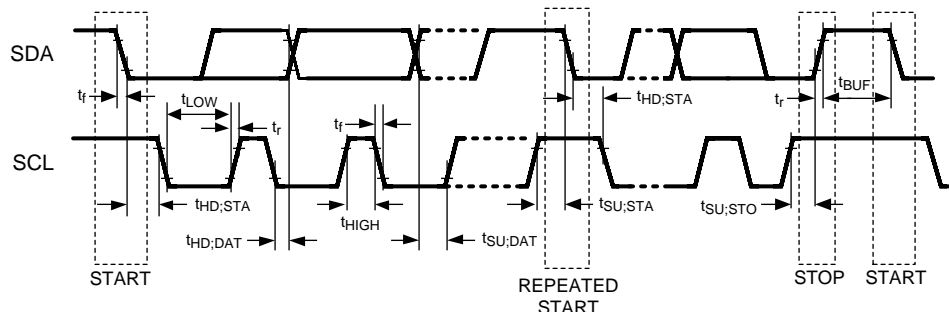

Figure 8. Serial Control Bus Timing Diagram

Timing Diagrams and Test Circuits (continued)

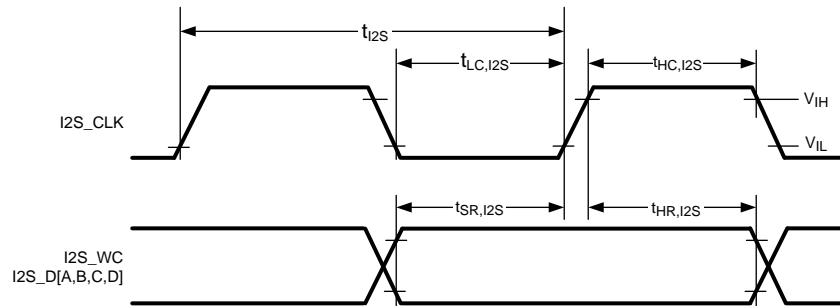

Figure 9. I2S Timing

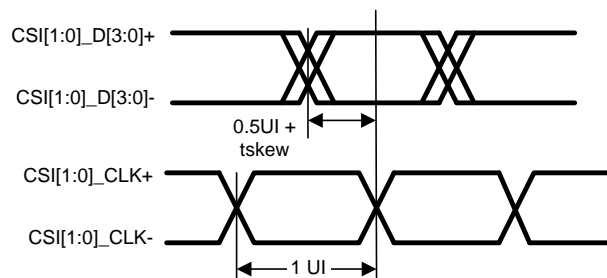

Figure 10. Clock and Data Timing in HS Transmission

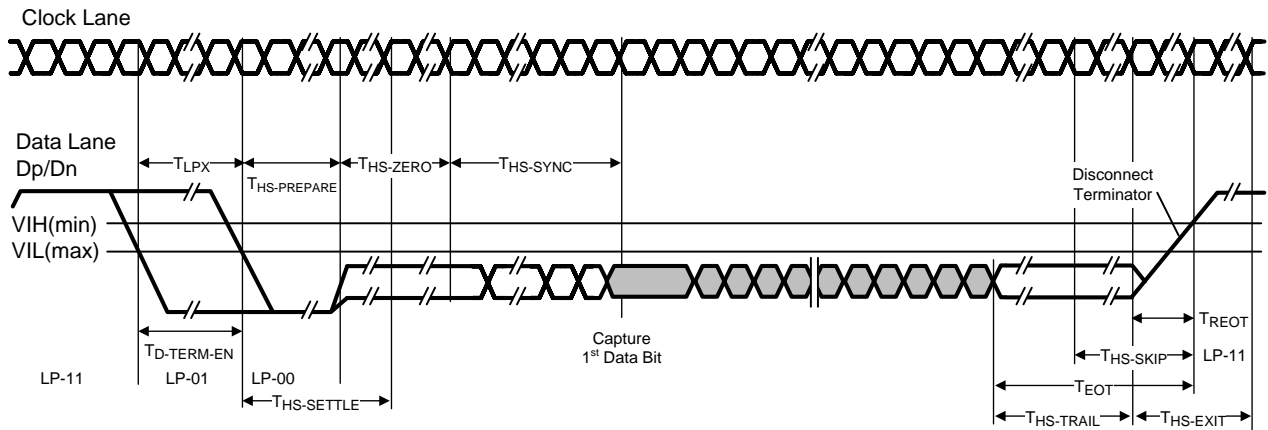

Figure 11. High Speed Data Transmission Burst

Timing Diagrams and Test Circuits (continued)

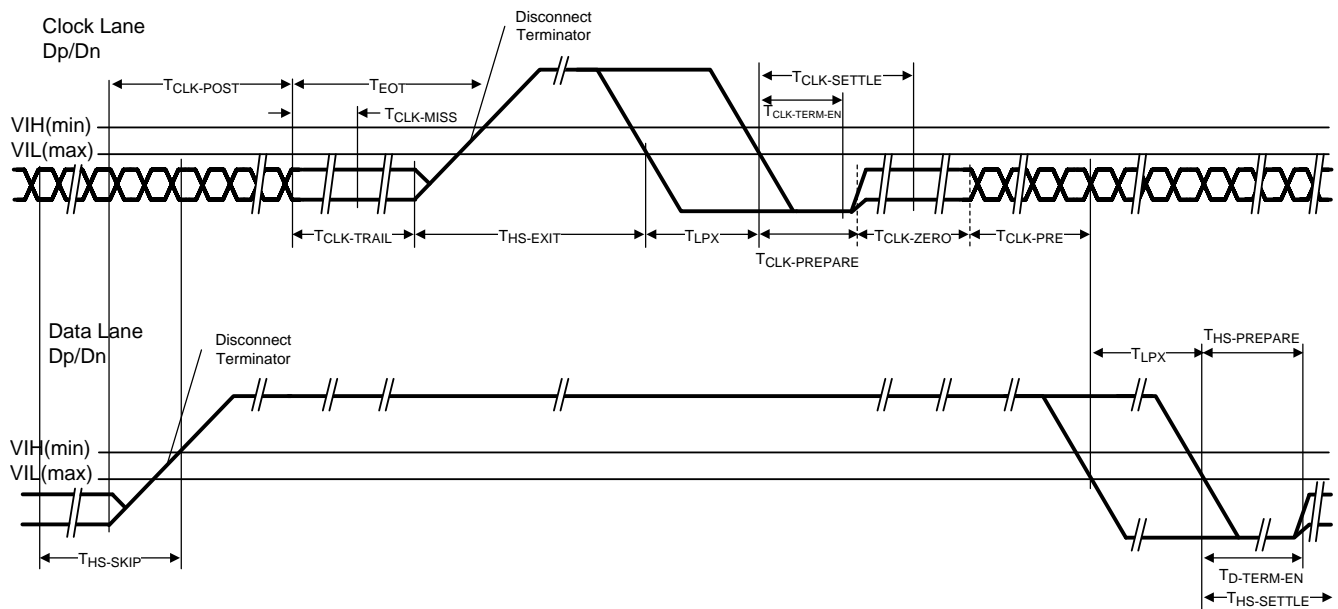

Figure 12. Switching the Clock Lane between Clock Transmission and Low-Power Mode

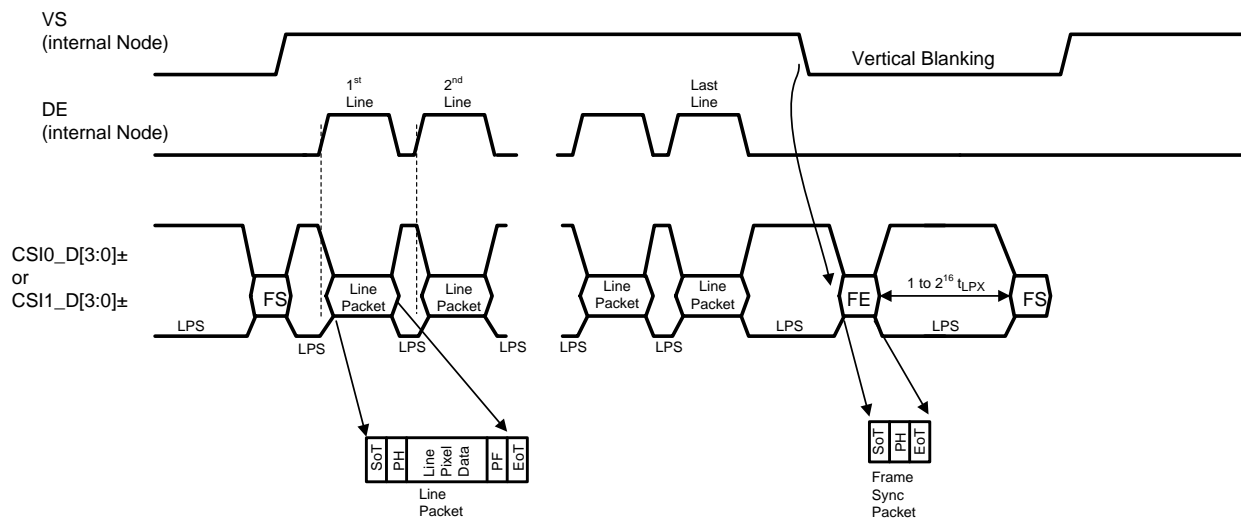

Figure 13. Long Line Packets and Short Frame Sync Packets

Timing Diagrams and Test Circuits (continued)

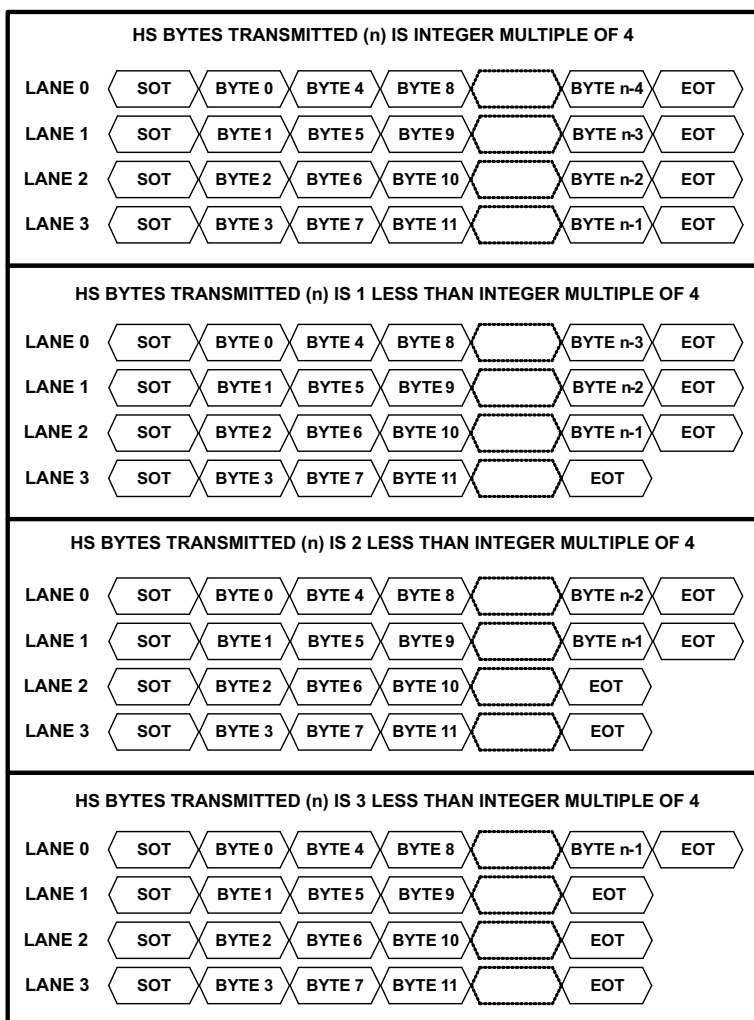

Figure 14. 4 MIPI Data Lane Configuration

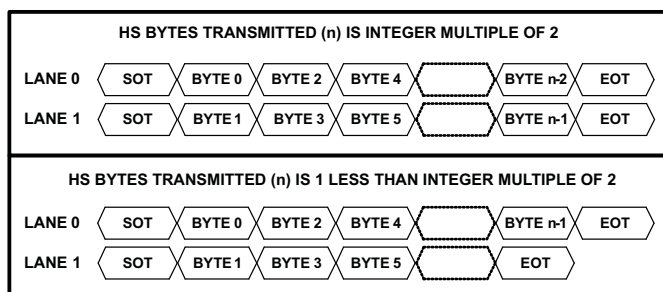
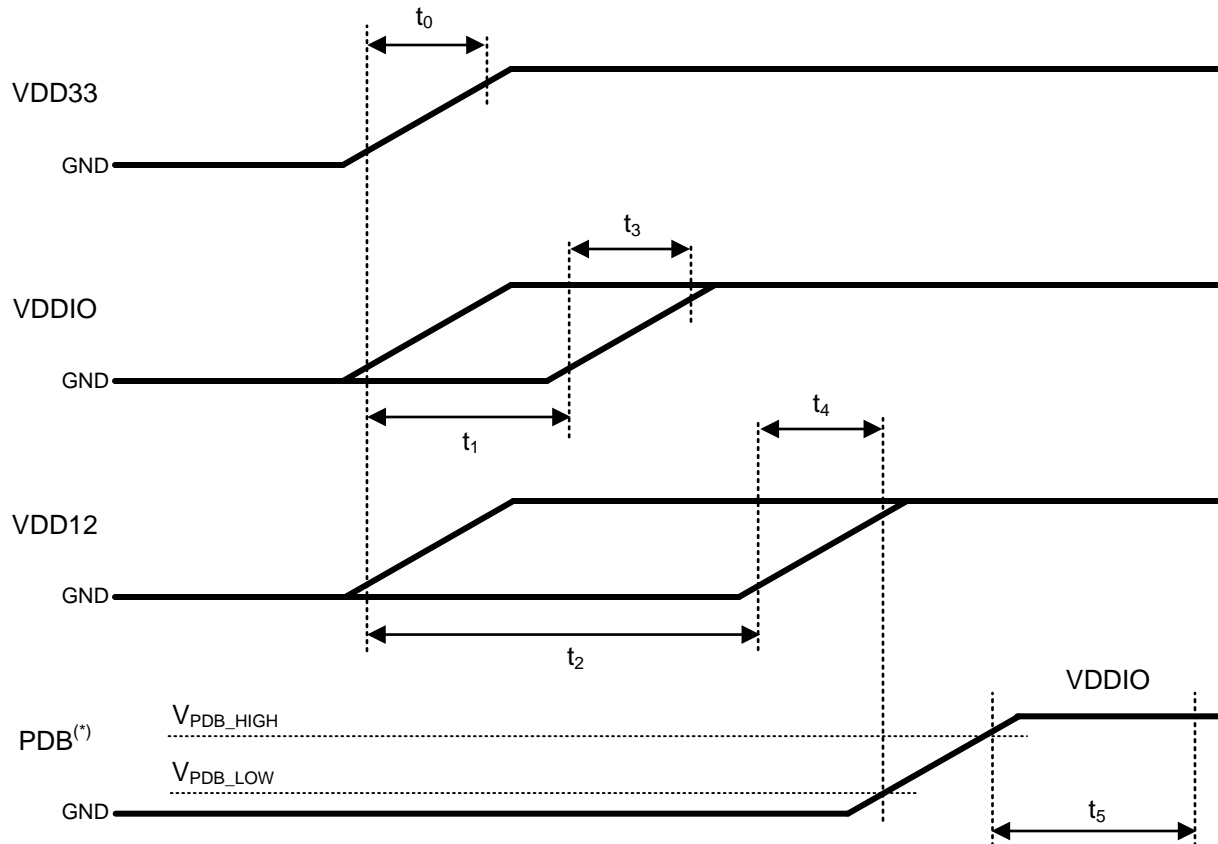

Figure 15. 2 MIPI Data Lane Configuration

## 7.11 Power Sequence



(\*) It is recommended to assert PDB (active High) with a microcontroller rather than an RC filter network to help ensure proper sequencing of PDB pin after settling of power supplies.

**Figure 16. Power Sequence**

**Table 1. Power-Up Sequencing Constraints**

Symbol	Description	Test Conditions	Min	Typ	Max	Units
VDDIO	VDDIO voltage range		3.0		3.6	V
			1.71		1.89	V
VDD33	VDD33 voltage range		3.0		3.6	V
VDD12	VDD12 voltage range		1.14		1.26	V
$V_{PDB\_LOW}$	PDB LOW threshold Note: $V_{PDB}$ should not exceed limit for respective I/O voltage before 90% voltage of VDD12	$VDDIO = 3.3V \pm 10\%$	0.8			V
		$VDDIO = 1.8V \pm 5\%$	$0.35 * VDDIO$			
$V_{PDB\_HIGH}$	PDB HIGH threshold	$VDDIO = 3.3V \pm 10\%$			2.0	V
		$VDDIO = 1.8V \pm 5\%$			$0.65 * VDDIO$	
$t_0$	VDD33 rise time	These time constants are specified for rise time of power supply voltage ramp (10% - 90%)			<1.5	ms
$t_3$	VDDIO rise time	These time constants are specified for rise time of power supply voltage ramp (10% - 90%)			<1.5	ms

Power Sequence (continued)

Table 1. Power-Up Sequencing Constraints (continued)

Symbol	Description	Test Conditions	Min	Typ	Max	Units
$t_4$	VDD12 rise time	These time constants are specified for rise time of power supply voltage ramp (10% - 90%)			<1.5	ms
$t_1$	VDDIO delay time	$V_{IL}$ of rising edge (VDDIO ) to $V_{IL}$ of rising edge (VDD_N) The power supplies may be ramped simultaneously. If sequenced, VDD33 should be first, either by itself or with VDDIO (1.8V or 3.3V) or VDD12, with the other rail(s) following in any order.	>0			ms
$t_2$	VDD12 delay time					
$t_5$	Startup time	The part is powered up after the startup time has elapsed from the moment PDB goes HIGH. Local I2C is available to read/write 948/940 registers after this time.			<1	ms

7.12 Typical Characteristics

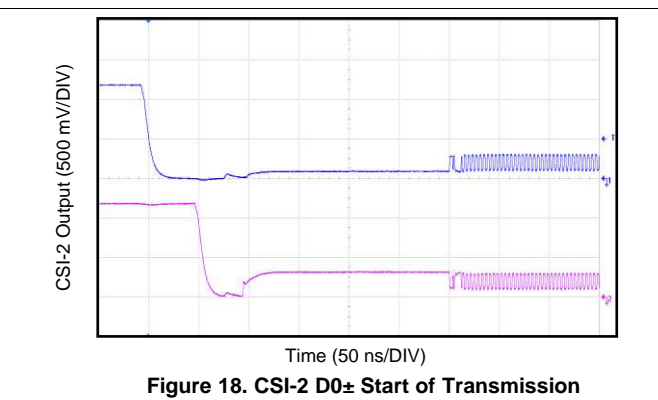
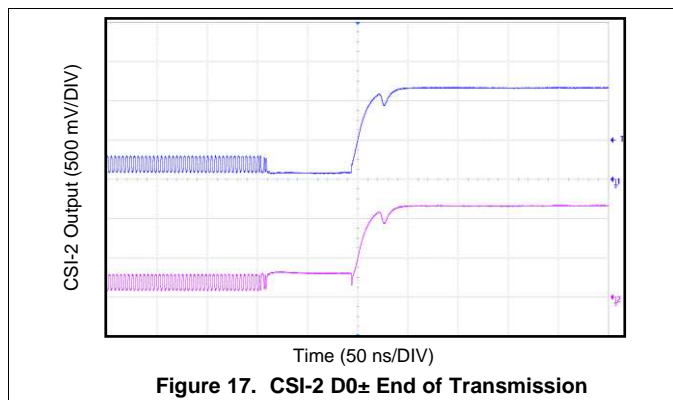

## 8 Detailed Description

### 8.1 Overview

The DS90UB940-Q1 receives a 35-bit symbol over single or dual serial FPD-Link III pairs operating at up to 3.36 Gbp line rate in 1-lane FPD-Link III mode and 2.975 Gbps per lane in 2-lane FPD-Link III mode. The DS90UB940-Q1 converts this stream into a CSI-2 MIPI Interface (4 data channels + 1 clock, or 8 data channels + 2 clocks in replicate mode). The FPD-Link III serial stream contains an embedded clock, video control signals, audio, GPIOs, I2C, and the DC-balanced video data and audio data which enhance signal quality to support AC coupling.

The DS90UB940-Q1 is intended for use with the DS90UB949-Q1 or DS90UB947-Q1 Serializers, but is also backward compatible to the DS90UB925Q-Q1, DS90UB925AQ-Q1, and DS90UB927Q-Q1 FPD-Link III Serializers.

The DS90UB940-Q1 deserializer attains lock to a data stream without the use of a separate reference clock source, which greatly simplifies system complexity and overall cost. The deserializer also synchronizes to the serializer regardless of the data pattern, delivering true automatic “plug and lock” performance. It can lock to the incoming serial stream without the need of special training patterns or sync characters. The deserializer recovers the clock and data by extracting the embedded clock information, validating then deserializing the incoming data stream.

The DS90UB940-Q1 deserializer incorporates an I2C compatible interface. The I2C compatible interface allows programming of serializer or deserializer devices from a local host controller. In addition, the devices incorporate a bidirectional control channel (BCC) that allows communication between serializer/deserializer as well as remote I2C slave devices.

The bidirectional control channel (BCC) is implemented via embedded signaling in the high-speed forward channel (serializer to deserializer) combined with lower speed signaling in the reverse channel (deserializer to serializer). Through this interface, the BCC provides a mechanism to bridge I2C transactions across the serial link from one I2C bus to another. The implementation allows for arbitration with other I2C compatible masters at either side of the serial link.

### 8.2 Functional Block Diagram

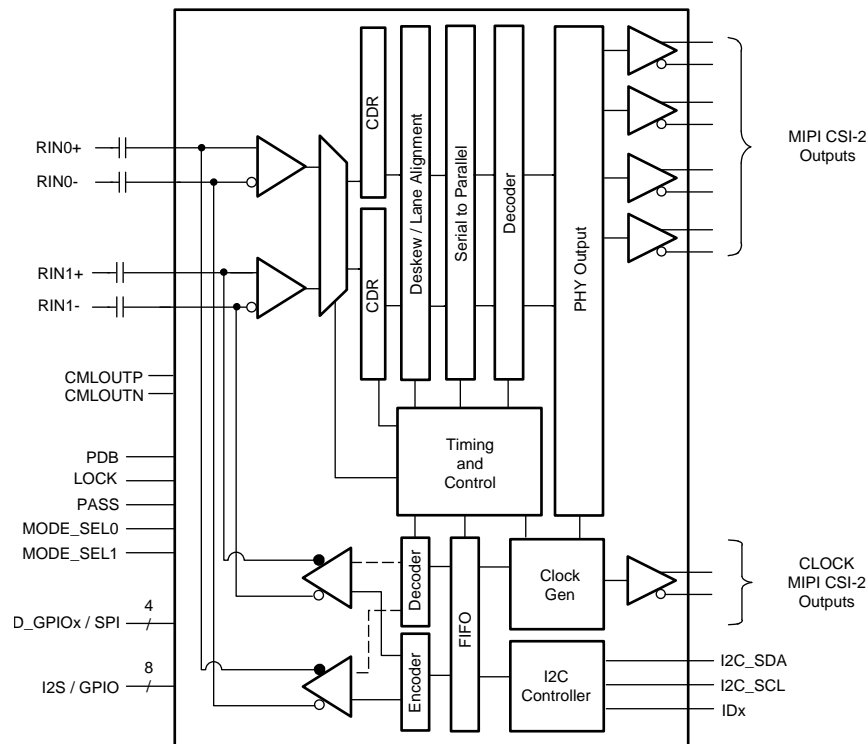



### 8.3 Feature Description

#### 8.3.1 High Speed Forward Channel Data Transfer

The High Speed Forward Channel is composed of 35 bits of data containing RGB data, sync signals, I2C, GPIOs, and I2S audio transmitted from serializer to deserializer. Figure 19 illustrates the serial stream per clock cycle. This data payload is optimized for signal transmission over an AC coupled link. Data is randomized, balanced and scrambled.



Figure 19. FPD-Link III Serial Stream

The DS90UB940-Q1 supports clocks in the range of 25 MHz to 96 MHz over a 1-lane, or 50MHz to 170MHz over 2-lanes. The FPD-Link III serial stream rate is 3.36 Gbps maximum (875 Mbps minimum) or 2.975 Gbps maximum per lane (875 Mbps minimum) respectively.

#### 8.3.2 Low Speed Back Channel Data Transfer

The Low-Speed Backward Channel provides bidirectional communication between the display and host processor. The information is carried from the deserializer to the serializer as serial frames. The back channel control data is transferred over both serial links along with the high-speed forward data, DC balance coding and embedded clock information. This architecture provides a backward path across the serial link together with a high speed forward channel. The back channel contains the I2C, CRC and 4 bits of standard GPIO information with 5 or 20 Mbps line rate (configured by MODE\_SEL1).

#### 8.3.3 FPD-Link III Port Register Access

Since the DS90UB940-Q1 contains two ports, some registers need to be duplicated to allow control and monitoring of the two ports. To facilitate this, PORT1\_SEL and PORT0\_SEL bits (0x34[1:0]) register controls access to the two sets of registers. Registers that are shared between ports (not duplicated) will be available independent of the settings in the PORT\_SEL register.

Setting the PORT1\_SEL and PORT0\_SEL bit will allow a read of the register for the selected port. If both bits are set, port1 registers will be returned. Writes will occur to ports for which the select bit is set, allowing simultaneous writes to both ports if both select bits are set.

#### 8.3.4 Clock and Output Status

When PDB is driven HIGH, the CDR PLL begins locking to the serial input and LOCK is tri-state or LOW (depending on the value of the OUTPUT ENABLE setting). After the deserializer completes its lock sequence to the input serial data, the LOCK output is driven HIGH, indicating valid data and clock recovered from the serial input is available on the LVCMOS and LVDS outputs. The State of the outputs is based on the OUTPUT ENABLE and OUTPUT SLEEP STATE SELECT register settings. See register 0x02 in Table 12.

Table 2. Output State Table

Serial Input	Inputs			Outputs			
	PDB	OUTPUT ENABLE Reg 0x02 [7]	OUTPUT SLEEP STATE SELECT Reg 0x02 [4]	LOCK	PASS	Data GPIO / D_GPIO I2S	CSI-2 Output
X	L	X	X	Z	Z	Z	Z
X	H	L	L	L or H	L	L	HS0
X	H	L	H	L or H	Z	Z	Z
Static	H	H	L	L	L	L	HS0
Static	H	H	H	L	Previous Status	L	HS0
Active	H	H	L	L	L	L	HS0
Active	H	H	H	H	Valid	Valid	Valid

### 8.3.5 LVCMOS VDDIO Option

The 1.8V or 3.3V Inputs and Outputs are powered from a separate VDDIO supply to offer compatibility with external system interface signals.

#### NOTE

When configuring the VDDIO power supplies, all the single-ended data and control input pins for device need to scale together with the same operating VDDIO levels.

### 8.3.6 Power Down (PDB)

The deserializer has a PDB input pin to ENABLE or POWER DOWN the device. This pin can be controlled by the host or through the VDDIO, where VDDIO = 3.0 V to 3.6 V or VDD33. To save power, disable the link when the display is not needed (PDB = LOW). When the pin is driven by the host, make sure to release it after VDD33 and VDDIO have reached final levels; no external components are required. In the case of driven by the VDDIO = 3.0 V to 3.6 V or VDD33 directly, a 10kΩ resistor to the VDDIO = 3.0 V to 3.6 V or VDD33, and a >10 μF capacitor to the GND are required (see [Figure 37](#) Typical Connection Diagram).

### 8.3.7 Interrupt Pin — Functional Description and Usage (INTB\_IN)

The INTB\_IN pin is an active low interrupt input pin. This interrupt signal, when configured, will propagate to the paired serializer. Consult the appropriate Serializer datasheet for details of how to configure this interrupt functionality.

1. On the Serializer, set register 0xC6[5] = 1 and 0xC6[0] = 1
2. Deserializer INTB\_IN (pin 4) is set *LOW* by some downstream device.
3. Serializer pulls INTB pin *LOW*. The signal is active *LOW*, so a *LOW* indicates an interrupt condition.
4. External controller detects INTB = *LOW*; to determine interrupt source, read ISR register.
5. A read to ISR will clear the interrupt at the Serializer, releasing INTB.
6. The external controller typically must then access the remote device to determine downstream interrupt source and clear the interrupt driving the Deserializer INTB\_IN. This would be when the downstream device releases the INTB\_IN (pin 4) on the Deserializer. The system is now ready to return to step (2) at next falling edge of INTB\_IN.

### 8.3.8 General-purpose I/O

#### 8.3.8.1 GPIO[3:0] and D\_GPIO[3:0] Configuration

In normal operation, GPIO[3:0] may be used as general purpose I/Os in either forward channel (outputs) or back channel (inputs) mode. GPIO and D\_GPIO modes may be configured from the registers ([Table 11](#)). The same registers configure either GPIO or D\_GPIO, depending on the status of PORT1\_SEL and PORT0\_SEL bits (0x34[1:0]). D\_GPIO operation requires 2-lane FPD-Link III mode. Consult the appropriate Serializer datasheet for details on D\_GPIO configuration. Note: if paired with a DS90UB925Q-Q1 serializer, the devices must be configured into 18-bit mode to allow usage of GPIO pins on the serializer. To enable 18-bit mode, set serializer register 0x12[2] = 1. 18-bit mode will be auto-loaded into the deserializer from the serializer. See [Table 3](#) for GPIO enable and configuration.

**Table 3. GPIO Enable and Configuration**

Description	Device	Forward Channel	Back Channel
GPIO3 / D_GPIO3	Serializer	0x0F[3:0] = 0x3	0x0F[3:0] = 0x5
	Deserializer	0x1F[3:0] = 0x5	0x1F[3:0] = 0x3
GPIO2 / D_GPIO2	Serializer	0x0E[7:4] = 0x3	0x0E[7:4] = 0x5
	Deserializer	0x1E[7:4] = 0x5	0x1E[7:4] = 0x3
GPIO1 / D_GPIO1	Serializer	0x0E[3:0] = 0x3	0x0E[3:0] = 0x5
	Deserializer	0x1E[3:0] = 0x5	0x1E[3:0] = 0x3
GPIO0 / D_GPIO0	Serializer	0x0D[3:0] = 0x3	0x0D[3:0] = 0x5
	Deserializer	0x1D[3:0] = 0x5	0x1D[3:0] = 0x3

The input value present on GPIO[3:0] or D\_GPIO[3:0] may also be read from register, or configured to local output mode (Table 11).

### 8.3.8.2 Back Channel Configuration

The D\_GPIO[3:0] pins can be configured to obtain different sampling rates depending on the mode as well as back channel frequency. The mode is controlled by register 0x43 (Table 11). The back channel frequency can be controlled several ways:

1. Register 0x23[6] sets the divider that controls the back channel frequency based on the internal oscillator. 0x23[6] = 0 sets the divider to 4 and 0x23[6] = 1 sets the divider to 2. As long as BC\_HS\_CTL (0x23[4]) is set to 0, the back channel frequency would be either 5 Mbps or 10Mbps based on this bit.
2. Register 0x23[4] enables the high-speed back channel. This can also be pin-strapped via MODE\_SEL1 (See Table 4). This bit overrides 0x23[6], and sets the divider for the back channel frequency to 1. Setting this bit to 1 sets the back channel frequency to 20 Mbps.

The back channel frequency has variation of  $\pm 20\%$ . Note: The back channel frequency must be set to 5 Mbps when paired with a DS90UB925Q-Q1, DS90UB925AQ-Q1, or DS90UB927Q-Q1. See Table 4 for details about configuring the D\_GPIOs in various modes.

**Table 4. Back Channel D\_GPIO Effective Frequency**

HSCC_MODE (0x43[2:0])	Mode	Number of D_GPIOs	Samples per Frame	D_GPIO Effective Frequency <sup>(1)</sup> (kHz)			D_GPIOs Allowed
				5 Mbps BC <sup>(2)</sup>	10 Mbps BC <sup>(3)</sup>	20 Mbps BC <sup>(4)</sup>	
000	Normal	4	1	33	66	133	D_GPIO[3:0]
011	Fast	4	6	200	400	800	D_GPIO[3:0]
010	Fast	2	10	333	666	1333	D_GPIO[1:0]
001	Fast	1	15	500	1000	2000	D_GPIO0

(1) The effective frequency assumes the worst case back channel frequency (-20%) and a 4X sampling rate.

(2) 5 Mbps corresponds to BC\_FREQ\_SELECT = 0 & BC\_HS\_CTL = 0

(3) 10 Mbps corresponds to BC\_FREQ\_SELECT = 1 & BC\_HS\_CTL = 0

(4) 20 Mbps corresponds to BC\_FREQ\_SELECT = X & BC\_HS\_CTL = 1

### 8.3.8.3 GPIO\_REG[8:5] Configuration

GPIO\_REG[8:5] are register-only GPIOs and may be programmed as outputs or read as inputs through local register bits only. Where applicable, these bits are shared with I2S pins and will override I2S input if enabled into GPIO\_REG mode. See Table 5 for GPIO enable and configuration.

Note: Local GPIO value may be configured and read either through local register access, or remote register access through the Low-Speed Bidirectional Control Channel. Configuration and state of these pins are not transported from serializer to deserializer as is the case for GPIO[3:0].

**Table 5. GPIO\_REG and GPIO Local Enable and Configuration**

Description	Register Configuration	Function
GPIO_REG8	0x21[7:4] = 0x1	Output, L
	0x21[7:4] = 0x9	Output, H
	0x21[7:4] = 0x3	Input, Read: 0x6F[0]
GPIO_REG7	0x21[3:0] = 0x1	Output, L
	0x21[3:0] = 0x9	Output, H
	0x21[3:0] = 0x3	Input, Read: 0x6E[7]
GPIO_REG6	0x20[7:4] = 0x1	Output, L
	0x20[7:4] = 0x9	Output, H
	0x20[7:4] = 0x3	Input, Read: 0x6E[6]
GPIO_REG5	0x20[3:0] = 0x1	Output, L
	0x20[3:0] = 0x9	Output, H
	0x20[3:0] = 0x3	Input, Read: 0x6E[5]

**Table 5. GPIO\_REG and GPIO Local Enable and Configuration (continued)**

Description	Register Configuration	Function
GPIO3	0x1F[3:0] = 0x1	Output, L
	0x1F[3:0] = 0x9	Output, H
	0x1F[3:0] = 0x3	Input, Read: 0x6E[3]
GPIO2	0x1E[7:4] = 0x1	Output, L
	0x1E[7:4] = 0x9	Output, H
	0x1E[7:4] = 0x3	Input, Read: 0x6E[2]
GPIO1	0x1E[3:0] = 0x1	Output, L
	0x1E[3:0] = 0x9	Output, H
	0x1E[3:0] = 0x3	Input, Read: 0x6E[1]
GPIO0	0x1D[3:0] = 0x1	Output, L
	0x1D[3:0] = 0x9	Output, H
	0x1D[3:0] = 0x3	Input, Read: 0x6E[0]

### 8.3.9 SPI Communication

The SPI Control Channel utilizes the secondary link in a 2-lane FPD-Link III implementation. Two possible modes are available, Forward Channel and Reverse Channel modes. In Forward Channel mode, the SPI Master is located at the Serializer, such that the direction of sending SPI data is in the same direction as the video data. In Reverse Channel mode, the SPI Master is located at the Deserializer, such that the direction of sending SPI data is in the opposite direction as the video data.

The SPI Control Channel can operate in a high speed mode when writing data, but must operate at lower frequencies when reading data. During SPI reads, data is clocked from the slave to the master on the SPI clock falling edge. Thus, the SPI read must operate with a clock period that is greater than the round trip data latency. On the other hand, for SPI writes, data can be sent at much higher frequencies where the MISO pin can be ignored by the master.

SPI data rates are not symmetrical for the two modes of operation. Data over the forward channel can be sent much faster than data over the reverse channel.

**Note:** SPI cannot be used to access Serializer / Deserializer registers.

#### 8.3.9.1 SPI Mode Configuration

SPI is configured over I2C using the High-Speed Control Channel Configuration (HSCC\_CONTROL) register, 0x43 (Table 12). HSCC\_MODE (0x43[2:0]) must be configured for either High-Speed, Forward Channel SPI mode (110) or High-Speed, Reverse Channel SPI mode (111).

#### 8.3.9.2 Forward Channel SPI Operation

In Forward Channel SPI operation, the SPI master located at the Serializer generates the SPI Clock (SPLK), Master Out / Slave In data (MOSI), and active low Slave Select (SS). The Serializer oversamples the SPI signals directly using the video pixel clock. The three sampled values for SPLK, MOSI, and SS are each sent on data bits in the forward channel frame. At the Deserializer, the SPI signals are regenerated using the pixel clock. In order to preserve setup and hold time, the Deserializer will hold MOSI data while the SPLK signal is high. In addition, it delays SPLK by one pixel clock relative to the MOSI data, increasing setup by one pixel clock.

SERIALIZER

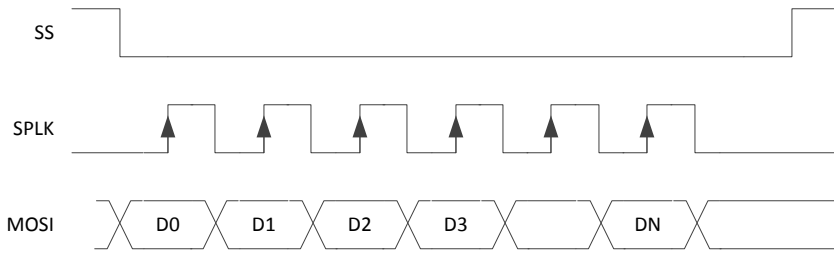

DESERIALIZER

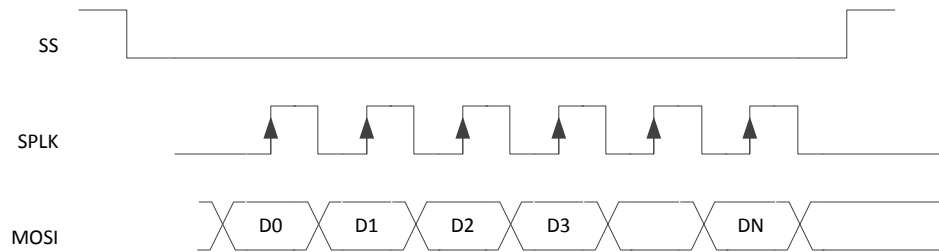
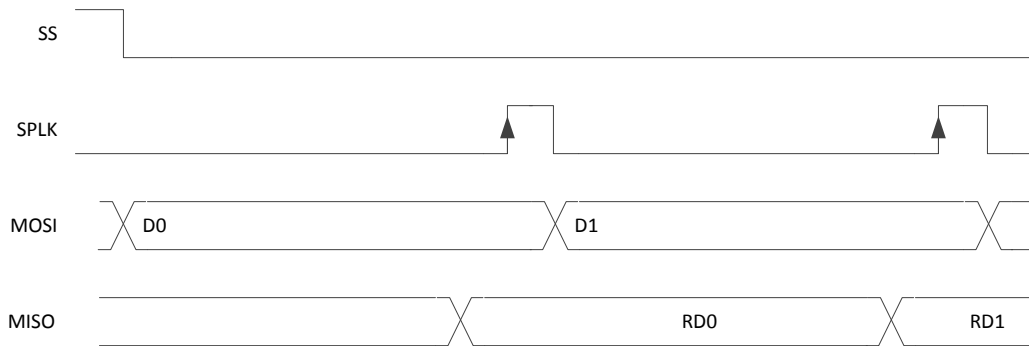

Figure 20. Forward Channel SPI Write

SERIALIZER



DESERIALIZER

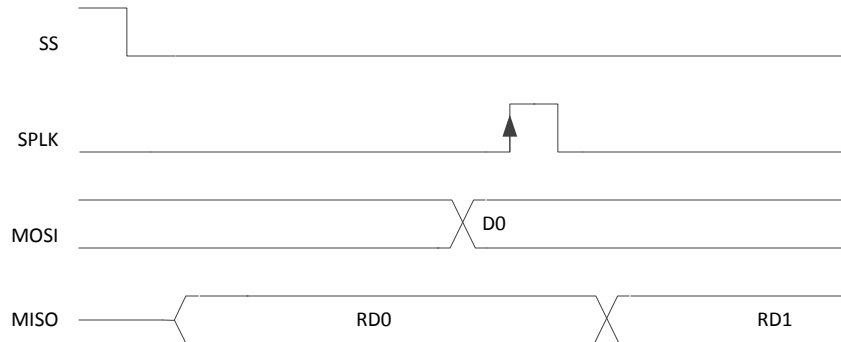
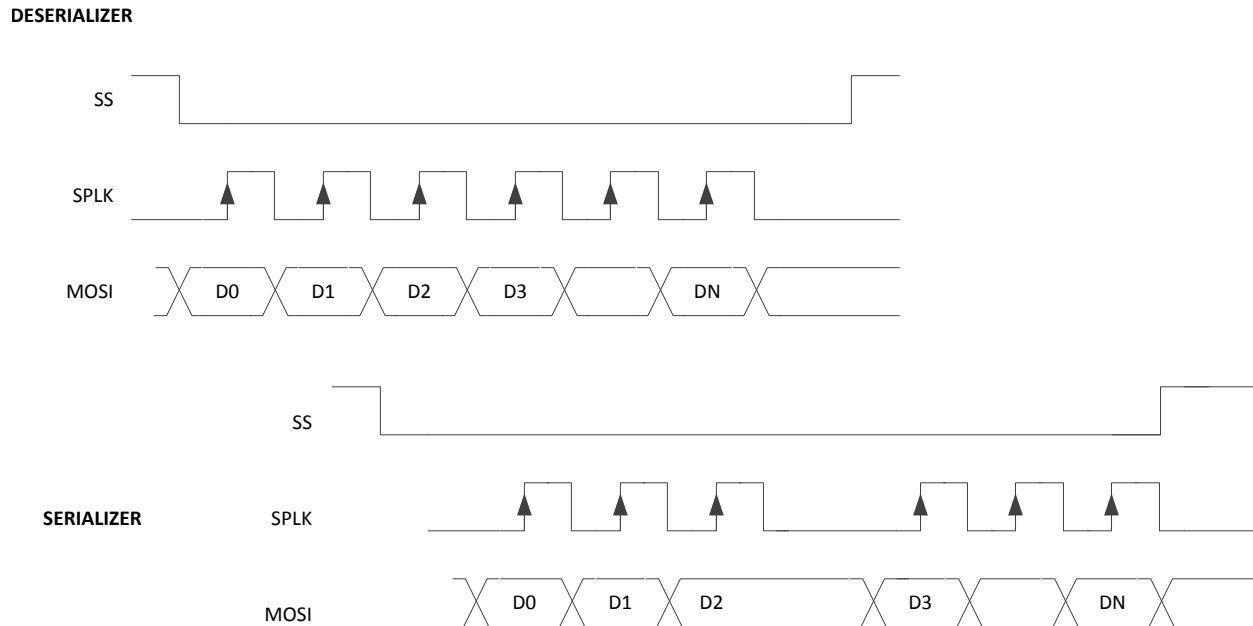

Figure 21. Forward Channel SPI Read

### 8.3.9.3 Reverse Channel SPI Operation

In Reverse Channel SPI operation, the Deserializer samples the Slave Select (SS), SPI clock (SCLK) into the internal oscillator clock domain. In addition, upon detection of the active SPI clock edge, the Deserializer samples the SPI data (MOSI). The SPI data samples are stored in a buffer to be passed to the Serializer over the back channel. The Deserializer sends SPI information in a back channel frame to the Serializer. In each back channel frame, the Deserializer sends an indication of the Slave Select value. The Slave Select should be inactive (high) for at least one back-channel frame period to ensure propagation to the Serializer.

Because data is delivered in separate back channel frames and buffered, the data may be regenerated in bursts. The following figure (Figure 22) shows an example of the SPI data regeneration when the data arrives in three back channel frames. The first frame delivered the SS active indication, the second frame delivered the first three data bits, and the third frame delivers the additional data bits.



**Figure 22. Reverse Channel SPI Write**

For Reverse Channel SPI reads, the SPI master must wait for a round-trip response before generating the sampling edge of the SPI clock. This is similar to operation in Forward channel mode. Note that at most one data/clock sample will be sent per back channel frame.

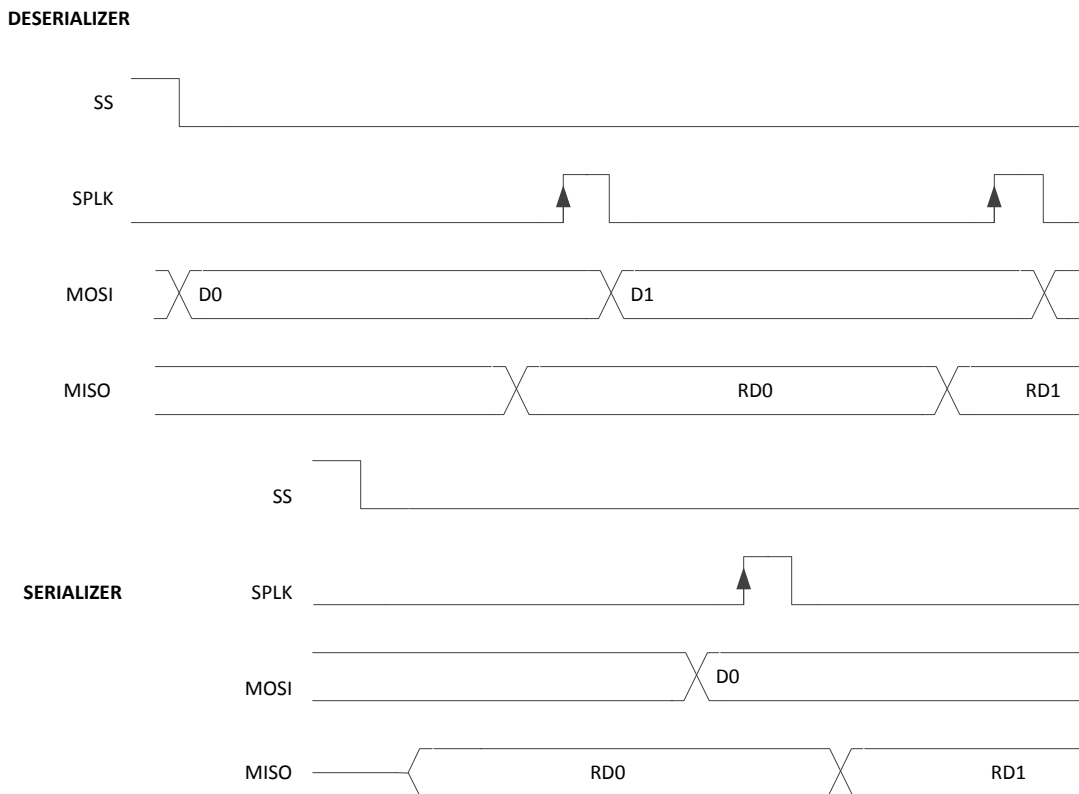

Figure 23. Reverse Channel SPI Read

For both Reverse Channel SPI writes and reads, the SPI\_SS signal should be deasserted for at least one back channel frame period.

Table 6. SPI SS Deassertion Requirement

Back Channel Frequency	Deassertion Requirement
5 Mbps	7.5 $\mu$ s
10 Mbps	3.75 $\mu$ s
20 Mbps	1.875 $\mu$ s

### 8.3.10 Backward Compatibility

The DS90UB940-Q1 is also backward compatible to the DS90UB925Q-Q1, DS90UB925AQ-Q1, and DS90UB927Q-Q1 for PCLK frequencies ranging from 25MHz to 85MHz. Backward compatibility does not need to be enabled. When paired with a backward compatible device, the Deserializer will auto-detect to 1-lane FPD-Link III on the primary channel (RIN0±).

### 8.3.11 Input Equalization

An FPD-Link III input adaptive equalizer provides compensation for transmission medium losses and reduces medium-induced deterministic jitter. It equalizes up to 15m STP or 50 $\Omega$  Coaxial cables with 3 connection breaks at maximum serializer stream payload of 3.36 Gbps.

### 8.3.12 I2S Audio Interface

This Deserializer features six I2S output pins that, when paired with a compatible serializer, supports surround sound audio applications. The bit clock (I2S\_CLK) supports frequencies between 1MHz and the smaller of <math>PCLK/2</math> or <math><13MHz</math>. Four I2S data outputs carry two channels of I2S-formatted digital audio each, with each channel delineated by the word select (I2C\_WC) input.

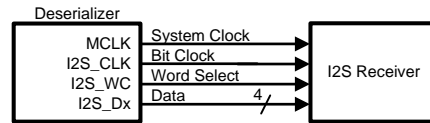
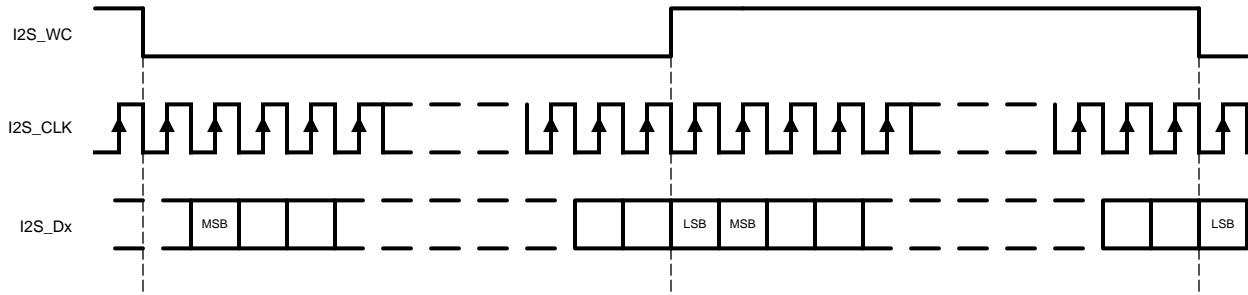
**Figure 24. I2S Connection Diagram**

**Figure 25. I2S Frame Timing Diagram**

When paired with a DS90UB925Q, the Deserializer I2S interface supports a single I2S data output through I2S\_DA (24-bit video mode), or two I2S data outputs through I2S\_DA and I2S\_DB (18-bit video mode).

### 8.3.12.1 I2S Transport Modes

By default, packetized audio is received during video blanking periods in dedicated Data Island Transport frames. The transport mode is set in the serializer and auto-loaded into the deserializer by default. The audio configuration may be disabled from control registers if Forward Channel Frame Transport of I2S data is desired. In frame transport, only I2S\_DA is received to the Deserializer. Surround Sound Mode, which transmits all four I2S data inputs (I2S\_D[D:A]), may only be operated in Data Island Transport mode. This mode is only available when connected to a DS90UB927Q, DS90UB949-Q1, DS90UB947-Q1, or DS90UB929-Q1 serializer. If connected to a DS90UB925Q serializer, only I2S\_DA and I2S\_DB may be received.

### 8.3.12.2 I2S Jitter Cleaning

This device features a standalone PLL to clean the I2S data jitter, supporting high-end car audio systems. If I2S\_CLK frequency is less than 1MHz, this feature must be disabled through register 0x2B[7]. See [Table 12](#).

### 8.3.12.3 MCLK

The deserializer has an I2S Master Clock Output (MCLK). It supports x1, x2, or x4 of I2S CLK Frequency. When the I2S PLL is disabled, the MCLK output is off. [Table 7](#) covers the range of I2S sample rates and MCLK frequencies. By default, all the MCLK output frequencies are x2 of the I2S CLK frequencies. The MCLK frequencies can also be enabled through the register bits 0x3A[6:4] (I2S DIVSEL), shown in [Table 12](#). To select desired MCLK frequency, write 0x3A[7], then write to bit [6:4] accordingly.



**Table 7. Audio Interface Frequencies**

Sample Rate (kHz)	I2S Data Word Size (bits)	I2S_CLK (MHz)	MCLK Output (MHz)	Register 0x3A[6:4]
32	16	1.024	I2S_CLK x1	000
			I2S_CLK x2	001
			I2S_CLK x4	010
44.1		1.4112	I2S_CLK x1	000
			I2S_CLK x2	001
			I2S_CLK x4	010
48		1.536	I2S_CLK x1	000
			I2S_CLK x2	001
			I2S_CLK x4	010
96		3.072	I2S_CLK x1	001
			I2S_CLK x2	010
			I2S_CLK x4	011
192	6.144	I2S_CLK x1	010	
		I2S_CLK x2	011	
		I2S_CLK x4	100	
32	24	1.536	I2S_CLK x1	000
			I2S_CLK x2	001
			I2S_CLK x4	010
44.1		2.117	I2S_CLK x1	001
			I2S_CLK x2	010
			I2S_CLK x4	011
48		2.304	I2S_CLK x1	001
			I2S_CLK x2	010
			I2S_CLK x4	011
96		4.608	I2S_CLK x1	010
			I2S_CLK x2	011
			I2S_CLK x4	100
192	9.216	I2S_CLK x1	011	
		I2S_CLK x2	100	
		I2S_CLK x4	101	
32	32	2.048	I2S_CLK x1	001
			I2S_CLK x2	010
			I2S_CLK x4	011
44.1		2.8224	I2S_CLK x1	001
			I2S_CLK x2	010
			I2S_CLK x4	011
48		3.072	I2S_CLK x1	001
			I2S_CLK x2	010
			I2S_CLK x4	011
96		6.144	I2S_CLK x1	010
			I2S_CLK x2	011
			I2S_CLK x4	100
192	12.288	I2S_CLK x1	011	
		I2S_CLK x2	100	
		I2S_CLK x4	110	

### 8.3.13 Built-In Self Test (BIST)

An optional At-Speed Built-In Self Test (BIST) feature supports testing of the high speed serial link and the low-speed back channel without external data connections. This is useful in the prototype stage, equipment production, in-system test, and system diagnostics.

#### 8.3.13.1 BIST Configuration And Status

The BIST mode is enabled at the deserializer by pin (BISTEN) or BIST configuration register. The test may select either an external PCLK or the 33 MHz internal Oscillator clock (OSC) frequency in the Serializer. In the absence of PCLK, the user can select the internal OSC frequency at the deserializer through the BISTC pin or BIST configuration register.

When BIST is activated at the deserializer, a BIST enable signal is sent to the serializer through the Back Channel. The serializer outputs a test pattern and drives the link at speed. The deserializer detects the test pattern and monitors it for errors. The deserializer PASS output pin toggles to flag each frame received containing one or more errors. The serializer also tracks errors indicated by the CRC fields in each back channel frame.

The BIST status can be monitored real time on the deserializer PASS pin, with each detected error resulting in a half pixel clock period toggled LOW. After BIST is deactivated, the result of the last test is held on the PASS output until reset (new BIST test or Power Down). A high on PASS indicates NO ERRORS were detected. A Low on PASS indicates one or more errors were detected. The duration of the test is controlled by the pulse width applied to the deserializer BISTEN pin. LOCK status is valid throughout the entire duration of BIST.

See [Figure 26](#) for the BIST mode flow diagram.

##### 8.3.13.1.1 Sample BIST Sequence

**Note:** Before BIST can be enabled, D\_GPIO0 (pin 19) must be strapped HIGH and D\_GPIO[3:1] (pins 16, 17, and 18) must be strapped LOW.

1. BIST Mode is enabled via the BISTEN pin of Deserializer. The desired clock source is selected through the deserializer BISTC pin.
2. The serializer is awakened through the back channel if it is not already on. An all-zeros pattern is balanced, scrambled, randomized, and sent through the FPD-Link III interface to the deserializer. Once the serializer and the deserializer are in BIST mode and the deserializer acquires LOCK, the PASS pin of the deserializer goes high and BIST starts checking the data stream. If an error in the payload (1 to 35) is detected, the PASS pin will switch low for one half of the clock period. During the BIST test, the PASS output can be monitored and counted to determine the payload error rate per 35 bits.
3. To Stop BIST mode, set the BISTEN pin LOW. The deserializer stops checking the data, and the final test result is held on the PASS pin. If the test ran error free, the PASS output will remain HIGH. If there one or more errors were detected, the PASS output will output constant LOW. The PASS output state is held until a new BIST is run, the device is RESET, or the device is powered down. BIST duration is user-controlled and may be of any length.

The link returns to normal operation after the deserializer BISTEN pin is low. [Figure 27](#) shows the waveform diagram of a typical BIST test for two cases. Case 1 is error free, and Case 2 shows one with multiple errors. In most cases it is difficult to generate errors due to the robustness of the link (differential data transmission etc.), thus they may be introduced by greatly extending the cable length, faulting the interconnect medium, or reducing signal condition enhancements (Rx Equalization).

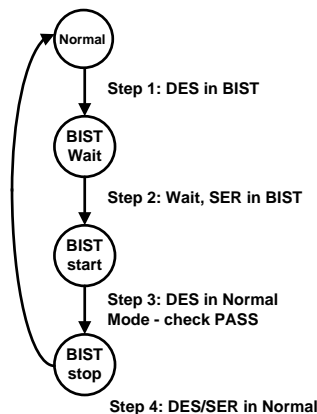

Figure 26. BIST Mode Flow Diagram

8.3.13.2 Forward Channel and Back Channel Error Checking

The Deserializer, on locking to the serial stream, compares the recovered serial stream with all-zeroes and records any errors in status registers. Errors are also dynamically reported on the PASS pin of the deserializer. Forward channel errors may also be read from register 0x25 (Table 12).

The back-channel data is checked for CRC errors once the serializer locks onto the back-channel serial stream, as indicated by link detect status (register bit 0x0C[0] - Table 12). CRC errors are recorded in an 8-bit register in the serializer. The register is cleared when the serializer enters the BIST mode. As soon as the serializer enters BIST mode, the functional mode CRC register starts recording any back channel CRC errors. The BIST mode CRC error register is active in BIST mode only and keeps the record of the last BIST run until cleared or the serializer enters BIST mode again.

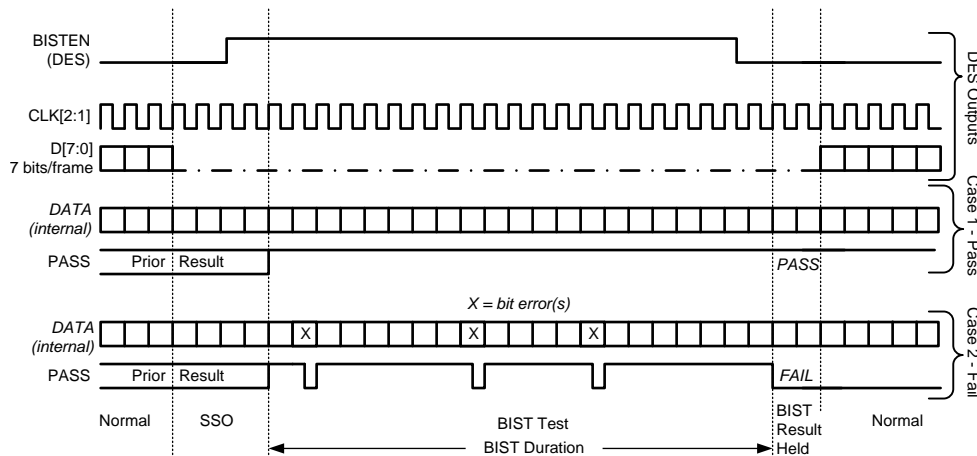

Figure 27. BIST Waveforms

8.3.14 Internal Pattern Generation

The deserializer supports the internal pattern generation feature. It allows basic testing and debugging of an integrated panel. The test patterns are simple and repetitive and allow for a quick visual verification of panel operation. As long as the device is not in power down mode, the test pattern will be displayed even if no parallel input is applied. If no PCLK is received, the test pattern can be configured to use a programmed oscillator frequency. For detailed information, refer to Application Note AN-2198 (SNLA132).

## 8.4 Device Functional Modes

### 8.4.1 Configuration Select

The DS90UB940-Q1 can be configured for several different operating modes via the MODE\_SEL[1:0] input pins, or via the register bits 0x23 [4:3] (MODE\_SEL1) and 0x6A [5:4] (MODE\_SEL0). A pull-up resistor and a pull-down resistor of suggested values may be used to set the voltage ratio of the MODE\_SEL[1:0] input and VDD33 to select one of the possible selected modes.

The DS90UB940-Q1 is capable of operating in either in 1-lane or 2-lane modes for FPD-Link III. By default, the FPD-Link III receiver automatically configures the input based on 1- or 2-lane mode operation. Programming register 0x34 [4:3] settings will override the automatic detection. For each FPD-Link III pair, the serial datastream is composed of a 35-bit symbol.

The DS90UB940-Q1 recovers the FPD-Link III serial datastream(s) and produces CSI-2 TX data driven to the MIPI DPHY interface. There are two CSI-2 ports (CSI0\_Dn and CSI1\_Dn) and each consist of one clock lane and four data lanes. The DS90UB940-Q1 supports two CSI-2 TX ports, and each may be configured to support either two or four CSI-2 data lanes. Unused CSI-2 outputs are driven to LP11 states. The MIPI DPHY transmission operates in both differential (HS) and single-ended (LP) modes. During HS transmission, the pair of outputs operates in differential mode; and in LP mode, the pair operates as two independent single-ended traces. Both the data and clock lanes enter LP mode during the horizontal and vertical blanking periods.

The configurations outlined in ([1-lane FPD-Link III Input, 4 MIPI lanes Output](#), [1-lane FPD-Link III Input, 2 MIPI lanes Output](#), [1- or 2-lane FPD-Link III Input, 2 or 4 MIPI lanes Output in Replicate](#)) will apply to DS90UB949-Q1, DS90UB947-Q1, DS90UB929-Q1, DS90UB925Q-Q1, DS90UB925AQ-Q1, and DS90UB927Q-Q1 FPD-Link III Serializers.

The configurations outlined in ([2-lane FPD-Link III Input, 4 MIPI lanes Output](#), [2-lane FPD-Link III Input, 2 MIPI lanes Output](#), [1- or 2-lane FPD-Link III Input, 2 or 4 MIPI lanes Output in Replicate](#)) will apply to DS90UB949-Q1 and DS90UB947-Q1 FPD-Link III Serializers.

The device can be configured in following modes:

- 1-lane FPD-Link III Input, 4 MIPI lanes Output
- 1-lane FPD-Link III Input, 2 MIPI lanes Output
- 2-lane FPD-Link III Input, 4 MIPI lanes Output
- 2-lane FPD-Link III Input, 4 MIPI lanes Output
- 1- or 2-lane FPD-Link III Input, 2 or 4 MIPI lanes Output (Replicate)

#### 8.4.1.1 1-lane FPD-Link III Input, 4 MIPI lanes Output

In this configuration the PCLK rate embedded within the 1-lane FPD-Link III frame can range from 25 MHz to 96 MHz, resulting in a link rate of 875 Mbps (35 bit \* 25 MHz) to 3.36 Gbps (35 bit \* 96 MHz). Each MIPI data lane will operate at a speed of 7 \* PCLK frequency; resulting in a data rate of 175 Mbps to 672 Mbps. The corresponding MIPI transmit clock rate will operate between 87.5 MHz to 336 MHz.

#### 8.4.1.2 1-lane FPD-Link III Input, 2 MIPI lanes Output

In this configuration the PCLK rate embedded within the 1-lane FPD-Link III frame can range from 25 MHz to 96 MHz, resulting in a link rate of 875 Mbps (35 bit \* 25 MHz) to 3.36 Gbps (35 bit \* 96 MHz). Each MIPI data lane will operate at a speed of 14 \* PCLK frequency; resulting in a data rate of 350 Mbps to 1344 Mbps. The corresponding MIPI transmit clock rate will operate between 175 MHz to 672 MHz.

#### 8.4.1.3 2-lane FPD-Link III Input, 4 MIPI lanes Output

In this configuration the PCLK rate embedded is split into 2-lane FPD-Link III frame and can range from 50 MHz to 170 MHz, resulting in a link rate of 875 Mbps (35 bit \* 25 MHz) to 2.975 Gbps (35 bit \* 85 MHz). The embedded datastreams from the received FPD-Link III inputs are merged in HS mode to form packets that carry the video stream. Each MIPI data lane will operate at a speed of 7 \* PCLK frequency, resulting in a data rate of 350 Mbps to 1190 Mbps. The corresponding MIPI transmit clock rate will operate between 175 MHz to 595 MHz.

## Device Functional Modes (continued)

### 8.4.1.4 2-lane FPD-Link III Input, 2 MIPI lanes Output

In this configuration the PCLK rate embedded is split into 2-lane FPD-Link III frame and can range from 25 MHz to 48 MHz, resulting in a link rate of 875 Mbps (35 bit \* 25 MHz) to 1.680 Gbps (35 bit \* 48 MHz). The embedded datastreams from the received FPD-Link III inputs are merged in HS mode to form packets that carry the video stream. Each MIPI data lane will operate at a speed of 14 \* PCLK frequency, resulting in a data rate of 700 Mbps to 1344 Mbps. The corresponding MIPI transmit clock rate will operate between 350 MHz to 672 MHz.

### 8.4.1.5 1- or 2-lane FPD-Link III Input, 2 or 4 MIPI lanes Output in Replicate

Same as 1- or 2-lane FPD-Link III Input(s), duplicates the MIPI CSI-2 lanes on CSI1\_D[3:0] and CSI1\_CLK outputs.

### 8.4.2 MODE\_SEL[1:0]

Configuration of the device may be done via the MODE\_SEL[1:0] input pins, or via the configuration register bits. A pull-up resistor and a pull-down resistor of suggested values may be used to set the voltage ratio of the MODE\_SEL[1:0] inputs ( $V_{R4}$ ) and VDD33 to select one of the other 8 possible selected modes. See [Table 8](#) and [Table 9](#). Possible configurations are shown in [Figure 28](#).

Device Functional Modes (continued)

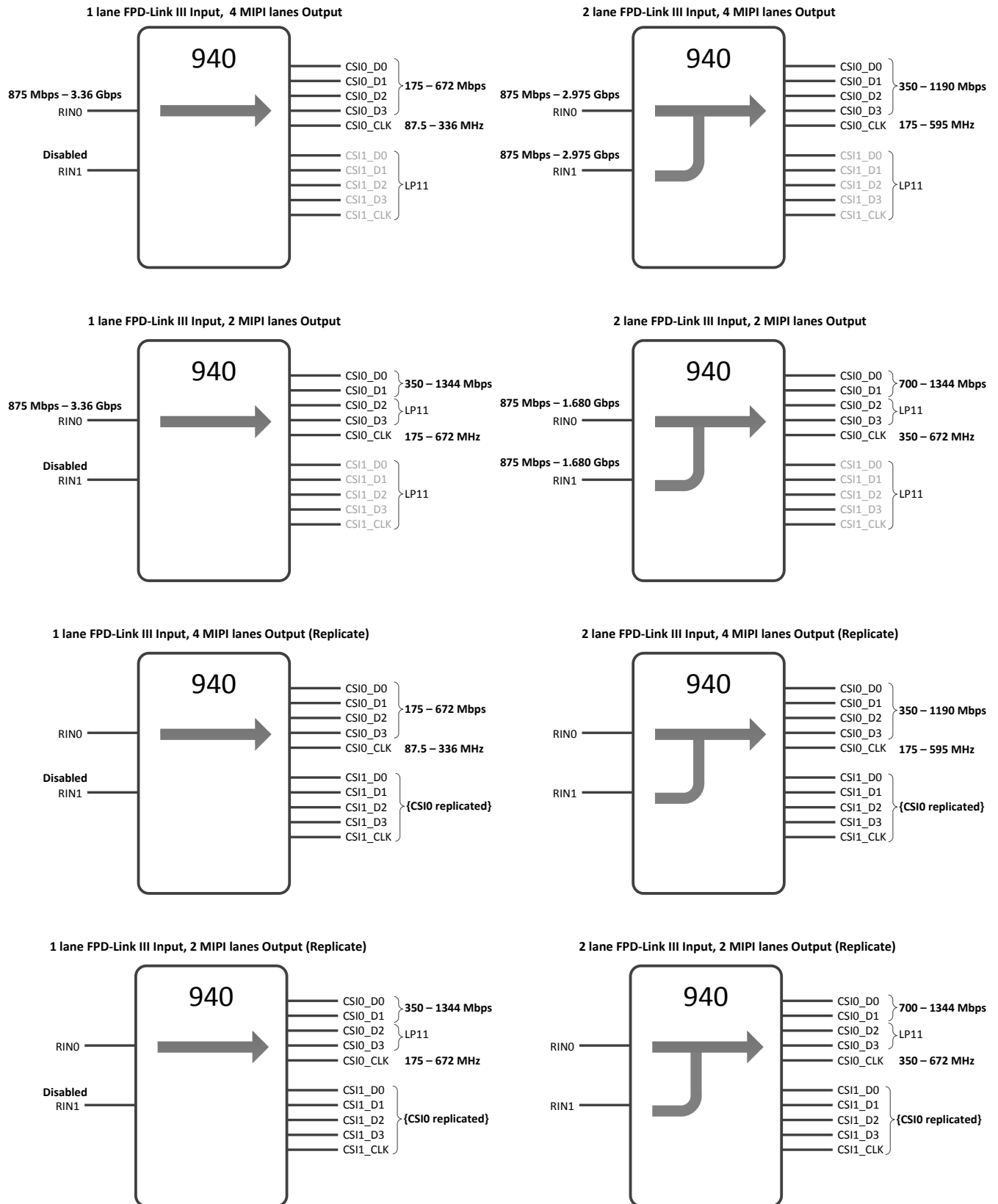

Figure 28. Datapath Configurations

## Device Functional Modes (continued)

Configuration of the device may be done via the MODE\_SEL[1:0] input pins, or via the configuration register bits. A pull-up resistor and a pull-down resistor of suggested values may be used to set the voltage ratio of the MODE\_SEL[1:0] inputs ( $V_{R1}$ ) and VDD33 to select one of the other 8 possible selected modes. See [Table 8](#) and [Table 9](#).

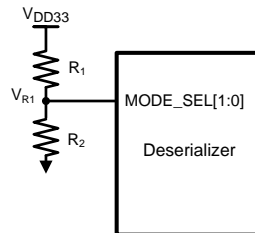

Figure 29. MODE\_SEL[1:0] Connection Diagram

Table 8. Configuration Select (MODE\_SEL0)

#	Ideal Ratio $V_{R1}/V_{DD33}$	Target $V_{R1}$ (V)	Suggested Resistor R1 k $\Omega$ (1% tol)	Suggested Resistor R2 k $\Omega$ (1% tol)	Output Mode
1	0	0	Open	40.2 or Any	4 data lanes 1 CSI port active (determined by MODE_SEL1 CSI_SEL bit)
2	0.169	0.559	232	47.5	4 data lanes both CSI ports active (overrides MODE_SEL1)
3	0.230	0.757	107	31.6	2 data lanes 1 CSI port active (determined by MODE_SEL1 CSI_SEL bit)
4	0.295	0.974	113	47.5	2 data lanes both CSI port active (overrides MODE_SEL1)
5	0.376	1.241	113	68.1	RESERVED
6	0.466	1.538	107	93.1	RESERVED
7	0.556	1.835	90.9	113	RESERVED
8	0.801	2.642	45.3	182	RESERVED

Table 9. Configuration Select (MODE\_SEL1)

#	Ideal Ratio $V_{R1}/V_{DD33}$	Target $V_{R1}$ (V)	Suggested Resistor R1 k $\Omega$ (1% tol)	Suggested Resistor R2 k $\Omega$ (1% tol)	CSI_SEL (CSI PORT)	High Speed Back Channel	Input Mode
1	0	0	Open	40.2 or Any	CSI0	5 Mbps	STP
2	0.169	0.559	232	47.5	CSI0	5 Mbps	Coax
3	0.230	0.757	107	31.6	CSI0	20 Mbps	STP
4	0.295	0.974	113	47.5	CSI0	20 Mbps	Coax
5	0.376	1.241	113	68.1	CSI1	5 Mbps	STP
6	0.466	1.538	107	93.1	CSI1	5 Mbps	Coax
7	0.556	1.835	90.9	113	CSI1	20 Mbps	STP
8	0.801	2.642	45.3	182	CSI1	20 Mbps	Coax

### 8.4.3 CSI-2 Interface

The DS90UB940-Q1 (in default mode) takes RGB 24-bpp data bits defined in the serializer and directly maps to the pixel color space in the data frame. The DS90UB940-Q1 follows the general frame format as described per the CSI-2 standard (Figure 30). Upon the end of the vertical sync pulse (VS), the DS90UB940-Q1 generates the Frame End and Frame Start synchronization packets within the vertical blanking period. The timing of the Frame Start will not reflect the timing of the VS signal.

Upon the rising edge of the DE signal, each active line is output in a long data packet with the defined data format (Figure 13). At the end of each packet, the data lanes  $D_{n\pm}$  return to the LP-11 state, while the clock lane  $CLK_{\pm}$  continue outputting the high speed clock.

The DS90UB940-Q1 CSI-2 transmitter consists of a high speed clock ( $CLK_{\pm}$ ) and data ( $D_{n\pm}$ ) outputs based on a source synchronous interface. The half rate clock at  $CLK_{\pm}$  is derived from the pixel clock sourced by the clock/data recovery circuit of the DS90UB940-Q1. The CSI-2 clock frequency is 3.5 times (4 MIPI lanes) or 7 times (2 MIPI lanes) the recovered pixel clock frequency. The MIPI DPHY outputs either 2 or 4 high speed data lanes ( $D_{n\pm}$ ) according to the CSI-2 protocol. The data rate of each lane is 7 times (4 MIPI lanes) or 14 times (2 MIPI lanes) the pixel clock. As an example in a 4 MIPI lane configuration, at a pixel clock of 150 MHz, the  $CLK_{\pm}$  runs at 525 MHz, and each data lane runs at 1050 Mbps.

The half-rate clock maintains a quadrature phase relationship to the data signals and allows receiver to sample data at the rising and falling edges of the clock (DDR). Figure 10 shows the timing relationship of the clock and data lines. The DS90UB940-Q1 supports continuous high speed clock. High speed data are sent out at data lanes  $D_{n\pm}$  in bursts. In between data bursts, the data lanes return to Low Power (LP) States in according to protocol defined in D-PHY standard. The rising edge of the differential clock ( $CSI\_CLK+$  –  $CSI\_CLK-$ ) is sent during the first payload bit of a transmission burst in the data lanes.

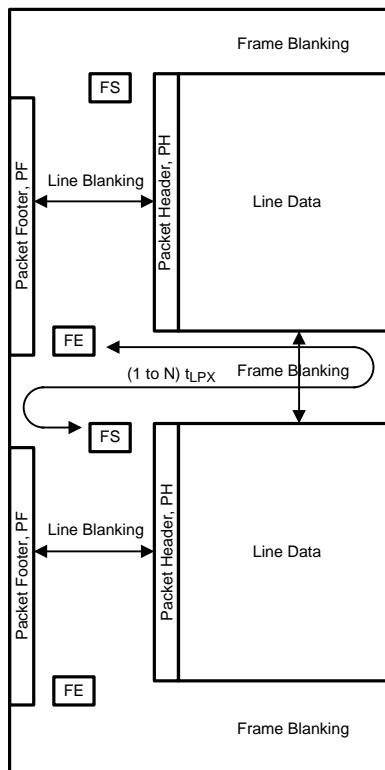

**Figure 30. CSI-2 General Frame Format**

### 8.4.4 Input Display Timing

The DS90UB940-Q1 has built-in support to detect the incoming video format extracted from the FPD-Link III datastream(s) and automatically generate CSI-2 output timing parameters accordingly. The input video format detection is derived from progressive display resolutions based on the CEA-861D specification. The video data rate and frame rate is determined by measuring internal VS and DE signals.



### 8.4.5 MIPI CSI-2 Output Data Formats

The DS90UB940-Q1 CSI-2 Tx supports multiple data types. These can be seen in [Table 10](#).

**Table 10. CSI-2 Output Data Formats<sup>(1)</sup>**

Data Format	CSI-2 Data Type [5:0]	Reg0x6B [3:2] IFMT	Reg0x6B [7:4] OFMT	Description
RGB888	0x24	00	0000	RGB888 image data – using 24-bit container for RGB 24-bpp
RGB666	0x23	00	0001	RGB666 image data
RGB565	0x22	00	0010	RGB565 image data
YUV420	0x1A	00	0011	YUV4:2:0 image data, Legacy YUV420 8-bit
YUV420 8-bit	0x18	00	0100	YUV4:2:0 image data
YUV422 8-bit	0x1E	00	0101	YUV4:2:2 image data
RAW8	0x2A	11	0110	RAW Bayer, 8-bit image data D[0:7] of Serializer inputs are used as RAW data; Alignment is configured with CSIIA_{0x6C}_0x09 [4]
RAW10	0x2B	11	0111	RAW Bayer, 10-bit image data D[0:9] of Serializer inputs are used as RAW data; Alignment is configured with CSIIA_{0x6C}_0x09 [4]
RAW12	0x2C	11	1000	RAW Bayer, 12-bit image data D[0:11] of Serializer inputs are used as RAW data; Alignment is configured with CSIIA_{0x6C}_0x09 [4]
YUV420 8-bit (CSPS)	0x1C	00	1001	YUV4:2:0 image data, YUV420 Chroma Shifted Pixel Sampling

(1) Note: Color space conversion is only available from RGB to YUV.

### 8.4.6 Non-Continuous / Continuous Clock

DS90UB940-Q1 D-PHY supports Continuous clock mode and Non-Continuous clock mode on the CSI-2 interface. Default mode is Non-Continuous Clock mode, where the Clock Lane enters in LP mode between the transmissions of data packets. Non-continuous clock mode will only be non-continuous during the vertical blanking period for lower PCLK rates. For higher PCLK rates, the clock will be non-continuous between line and frame packets. Operating modes are configurable through 0x6A [1].

Clock lane enters LP11 during horizontal blanking if the horizontal blanking period is longer than the overhead time to start/stop the clock lane. There is auto-detection of the length of the horizontal blank period. The fixed threshold is 96 PCLK cycles.

### 8.4.7 Ultra Low Power State (ULPS)

The DS90UB940-Q1 supports the MIPI defined Ultra-Low Power State (ULPS). DS90UB940-Q1 D-PHY lanes will enter ULPS mode upon software standby mode through 0x6A [2] generated by the processor. When ULPS is issued, all active CSI-2 lanes including the clock and data lanes of the enabled CSI-2 port are put in ULPS according to the MIPI DPHY protocol. D-PHY can reduce power consumption by entering ULPS mode. Ultra Low Power State is exited by means of a Mark-1 state with a length TWAKEUP followed by a Stop state.

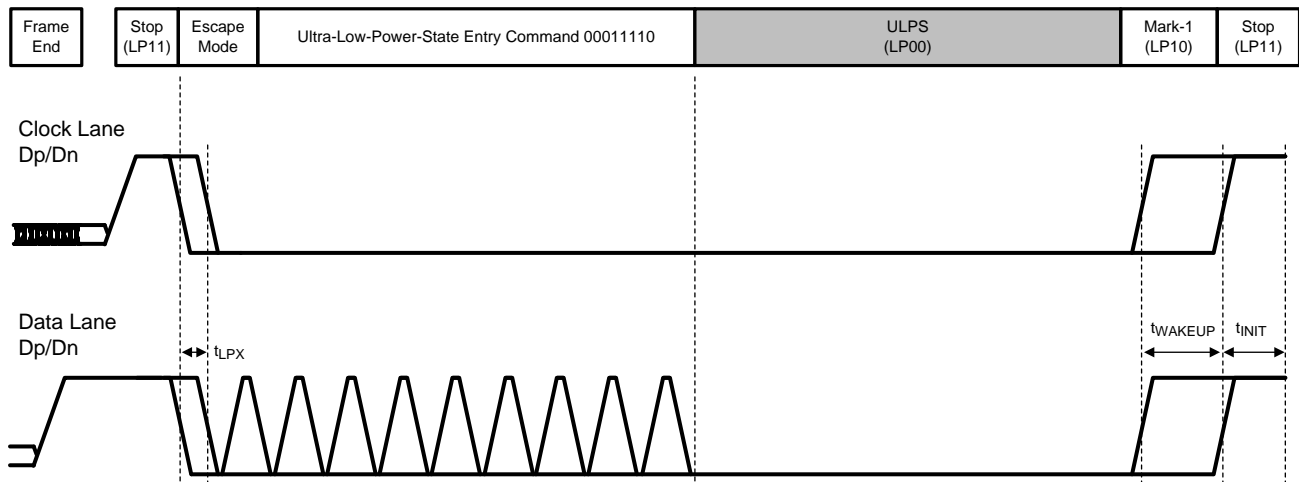
**Figure 31. Ultra Low Power State**

#### 8.4.8 CSI-2 Data Identifier

The DS90UB940-Q1 MIPI CSI-2 protocol interface transmits the data identifier byte containing the values for the virtual channel ID (VC) and data type (DT) for the application specific payload data, as shown in [Figure 32](#). The virtual channel ID is contained in the 2 MSBs of the data identifier byte and identify the data as directed to one of four virtual channels. The value of the data type is contained in the 6 LSBs of the data identifier byte.

- CSIIA\_{0x6C}\_0x2E[7:6] CSI\_VC\_ID: Configures the virtual ID linked to the current context.
- CSICFG1\_0x6B[7:4] OFMT: Configures the data format linked to the current context.

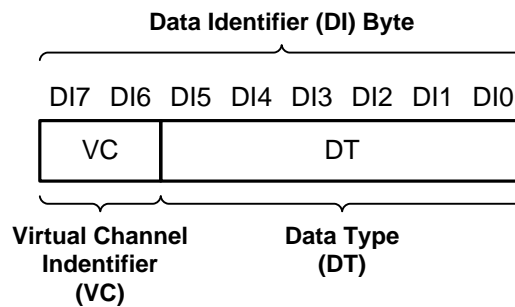
**Figure 32. CSI-2 Data Identifier Structure**

## 8.5 Programming

### 8.5.1 Serial Control Bus

The device may also be configured by the use of a I2C compatible serial control bus. Multiple devices may share the serial control bus (up to 8 device addresses supported). The device address is set via a resistor divider (R1 and R2 — see Figure 33 below) connected to the IDx pin.

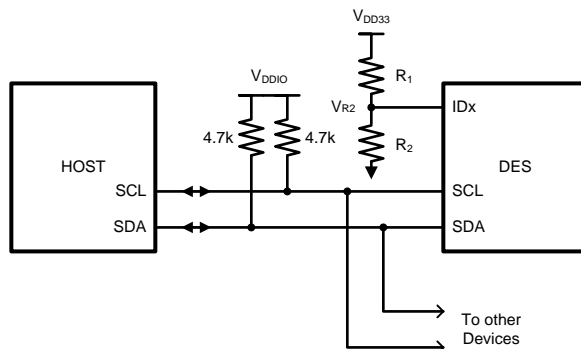

Figure 33. Serial Control Bus Connection

The serial control bus consists of two signals, SCL and SDA. SCL is a Serial Bus Clock Input. SDA is the Serial Bus Data Input / Output signal. Both SCL and SDA signals require an external pull-up resistor to 1.8 V or 3.3 V VDDIO. For most applications, a 4.7kΩ pull-up resistor to VDD33 is recommended. However, the pull-up resistor value may be adjusted for capacitive loading and data rate requirements. The signals are either pulled High, or driven Low.

The IDx pin configures the control interface to one of 8 possible device addresses. A pull-up resistor and a pull-down resistor may be used to set the appropriate voltage ratio between the IDx input pin ( $V_{R2}$ ) and VDD33, each ratio corresponding to a specific device address. See Table 11 below.

Table 11. Serial Control Bus Addresses for IDx

#	Ideal Ratio $V_{R2} / V_{DD33}$	Ideal $V_{R2}$ (V)	Suggested Resistor R1 kΩ (1% tol)	Suggested Resistor R2 kΩ (1% tol)	7-bit Address	8-bit Address
1	0	0	Open	40.2 or >10	0x2C	0x58
2	0.169	0.559	232	47.5	0x2E	0x5C
3	0.230	0.757	107	31.6	0x30	0x60
4	0.295	0.974	113	47.5	0x32	0x64
5	0.376	1.241	113	68.1	0x34	0x68
6	0.466	1.538	107	93.1	0x36	0x6C
7	0.556	1.835	90.9	113	0x38	0x70
8	0.801	2.642	45.3	182	0x3C	0x78

The Serial Bus protocol is controlled by START, START-Repeated, and STOP phases. A START occurs when SCL transitions Low while SDA is High. A STOP occurs when SDA transitions High while SCL is also HIGH. See Figure 34

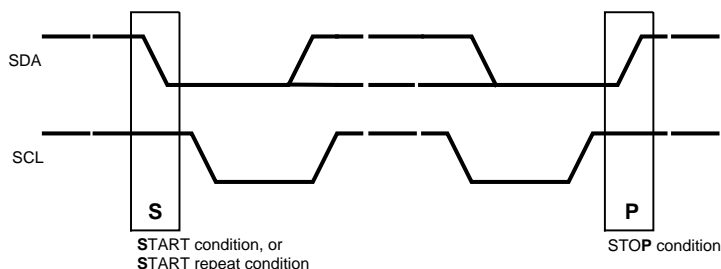
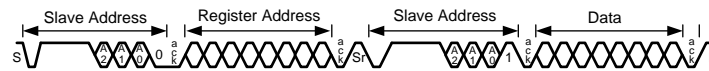
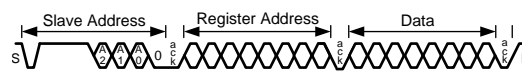

Figure 34. START and STOP Conditions

To communicate with a remote device, the host controller (master) sends the slave address and listens for a response from the slave. This response is referred to as an acknowledge bit (ACK). If a slave on the bus is addressed correctly, it Acknowledges (ACKs) the master by driving the SDA bus low. If the address doesn't match a device's slave address, it Not-acknowledges (NACKs) the master by letting SDA be pulled High. ACKs also occur on the bus when data is being transmitted. When the master is writing data, the slave ACKs after every data byte is successfully received. When the master is reading data, the master ACKs after every data byte is received to let the slave know it wants to receive another data byte. When the master wants to stop reading, it NACKs after the last data byte and creates a stop condition on the bus. All communication on the bus begins with either a Start condition or a Repeated Start condition. All communication on the bus ends with a Stop condition. A READ is shown in Figure 35 and a WRITE is shown in Figure 36.



**Figure 35. Serial Control Bus — READ**



**Figure 36. Serial Control Bus — WRITE**

The I2C Master located at the Deserializer must support I2C clock stretching. For more information on I2C interface requirements and throughput considerations, please refer to TI Application Note SNLA131.

### 8.5.2 Multi-Master Arbitration Support

The Bidirectional Control Channel in the FPD-Link III devices implements I2C compatible bus arbitration in the proxy I2C master implementation. When sending a data bit, each I2C master senses the value on the SDA line. If the master is sending a logic 1 but senses a logic 0, the master has lost arbitration. It will stop driving SDA, retrying the transaction when the bus becomes idle. Thus, multiple I2C masters may be implemented in the system.

For example, there might also be a local I2C master at each camera. The local I2C master could access the Image Sensor and EEPROM. The only restriction would be that the remote I2C master at the camera should not attempt to access a remote slave through the BCC that is located at the host controller side of the link. In other words, the control channel should only operate in camera mode for accessing remote slave devices to avoid issues with arbitration across the link. The remote I2C master should also not attempt to access the deserializer registers to avoid a conflict in register access with the Host controller.

If the system does require master-slave operation in both directions across the BCC, some method of communication must be used to ensure only one direction of operation occurs at any time. The communication method could include using available read/write registers in the deserializer to allow masters to communicate with each other to pass control between the two masters. An example would be to use register 0x18 or 0x19 in the deserializer as a mailbox register to pass control of the channel from one master to another.

### 8.5.3 I2C Restrictions on Multi-Master Operation

The I2C specification does not provide for arbitration between masters under certain conditions. The system should make sure the following conditions cannot occur to prevent undefined conditions on the I2C bus:

- One master generates a repeated Start while another master is sending a data bit.
- One master generates a Stop while another master is sending a data bit.
- One master generates a repeated Start while another master sends a Stop.

Note that these restrictions mainly apply to accessing the same register offsets within a specific I2C slave.

### 8.5.4 Multi-Master Access to Device Registers for Newer FPD-Link III Devices

When using the latest generation of FPD-Link III devices (DS90UB94x-Q1), serializers or deserializer registers may be accessed simultaneously from both local and remote I2C masters. These devices have internal logic to properly arbitrate between sources to allow proper read and write access without risk of corruption.

Access to remote I2C slaves would still be allowed in only one direction at a time (Camera or Display mode).

### 8.5.5 Multi-Master Access to Device Registers for Older FPD-Link III Devices

When using older FPD-Link III devices (in backward compatible), simultaneous access to serializer or deserializer registers from both local and remote I2C masters may cause incorrect operation, thus restrictions should be imposed on accessing of serializer and deserializer registers. The likelihood of an error occurrence is relatively small, but it is possible for collision on reads and writes to occur, resulting in an errored read or write.

Two basic options are recommended. The first is to allow device register access only from one controller. In a Display mode system, this would allow only the Host controller to access the serializer registers (local) and the deserializer registers (remote). A controller at the deserializer (local to the Display) would not be allowed to access the deserializer or serializer registers.

The second basic option is to allow local register access only with no access to remote serializer or deserializer registers. The Host controller would be allowed to access the serializer registers while a controller at the deserializer could access those register only. Access to remote I2C slaves would still be allowed in one direction (Camera or Display mode).

In a very limited case, remote and local access could be allowed to the deserializer registers at the same time. Register access is ensured to work correctly if both local and remote masters are accessing the same deserializer register. This allows a simple method of passing control of the Bidirectional Control Channel from one master to another.

### 8.5.6 Restrictions on Control Channel Direction for Multi-Master Operation

Only Display or Camera mode operation should be active at any time across the Bidirectional Control Channel. If both directions are required, some method of transferring control between I2C masters should be implemented.

## 8.6 Register Maps

**Table 12. Serial Control Bus Registers**

ADD (hex)	Register Name	Bit(s)	Function	Type	Default Value (hex)	Description
0x00	I2C Device ID	7:1	DEVICE ID	RW	Strap	7-bit address of Deserializer; Defaults to the address configured by the IDx strap pin. See <a href="#">Table 11</a> .
		0	DES ID	RW	0	0: Device ID is from IDx strap 1: Register I2C Device ID overrides IDx strap
0x01	Reset	7:3	RESERVED	RW	0	Reserved
		2	RESERVED	R	1	Reserved
		1	DIGITAL RESET0	RW	0	Digital Reset. Resets the entire digital block including registers. This bit is self-clearing. 1: Reset 0: Normal operation. Registers which are loaded by pin strap will be restored to their original strap value when this bit is set. These registers show 'Strap' as their default value in this table.
		0	DIGITAL RESET1	RW	0	Digital Reset. Resets the entire digital block except registers. This bit is self-clearing. 1: Reset 0: Normal operation
0x02	General Configuration 0	7	OUTPUT ENABLE	RW	1	Output Enable Override Value (in conjunction with Output Sleep State Select) If the Override control is not set, the Output Enable will be set to 1. A Digital reset 0x01[0] should be asserted after toggling Output Enable bit <i>LOW</i> to <i>HIGH</i>
		6	OUTPUT ENABLE OVERRIDE	RW	0	Overrides Output Enable and Output Sleep State default 0: Disable override 1: Enable override
		5	OSC CLOCK OUTPUT ENABLE (AUTO_CLOCK_EN)	RW	0	OSC clock output enable If loss of lock OSC clock is output onto PCLK. The frequency is selected in register 0x24. 1: Enable 0: Disable
		4	OUTPUT SLEEP STATE SELECT	RW	0	OSS Select Override value to control output state when LOCK is low (used in conjunction with Output Enable) If the Override control is not set, the Output Sleep State Select will be set to 1.
		3:0	RESERVED	RW	0	Reserved

**Register Maps (continued)**
**Table 12. Serial Control Bus Registers (continued)**

ADD (hex)	Register Name	Bit(s)	Function	Type	Default Value (hex)	Description
0x03	General Configuration 1	7	RESERVED	RW	1	Reserved
		6	BC CRC GENERATOR ENABLE	RW	1	Back Channel CRC Generator Enable 0: Enable 1: Disable (Default)
		5	FAILSAFE LOW	RW	1	Controls the pull direction for undriven LVCMOS inputs 1: Pull down 0: Pull up
		4	FILTER ENABLE	RW	1	HS,VS,DE two clock filter When enabled, pulses less than two full PCLK cycles on the DE, HS, and VS inputs will be rejected. 1: Filtering enable 0: Filtering disable
		3	I2C PASS-THROUGH	RW	0	I2C Pass-Through to Serializer if decode matches 0: Pass-Through Disabled 1: Pass-Through Enabled
		2	AUTO ACK	RW	0	Automatically Acknowledge I2C writes independent of the forward channel lock state 1: Enable 0: Disable
		1	DE GATE RGB	RW	0	Gate RGB data with DE signal. RGB data is gated with DE in order to allow packetized audio and block unencrypted data when paired with a serializer that supports HDCP. When paired with a serializer that does not support HDCP, RGB data is not gated with DE by default. However, to enable packetized audio this bit must be set. 1: Gate RGB data with DE (has no effect when paired with a serializer that supports HDCP) 0: Pass RGB data independent of DE (has no effect when paired with a serializer that does not support HDCP)
		0	RESERVED	RW	0	Reserved
0x04	BCC Watchdog Control	7:1	BCC WATCHDOG TIMER	RW	0x7F	The watchdog timer allows termination of a control channel transaction if it fails to complete within a programmed amount of time. This field sets the Bidirectional Control Channel Watchdog Timeout value in units of 2 milliseconds. This field should not be set to 0.
		0	BCC WATCHDOG TIMER DISABLE	RW	0	Disable Bidirectional Control Channel Watchdog Timer 1: Disables BCC Watchdog Timer operation 0: Enables BCC Watchdog Timer operation
0x05	I2C Control 1	7	I2C PASS THROUGH ALL	RW	0	I2C Pass-Through All Transactions 0: Disabled 1: Enabled
		6:4	I2C SDA HOLD	RW	0x1	Internal SDA Hold Time This field configures the amount of internal hold time provided for the SDA input relative to the SCL input. Units are 50 nanoseconds.
		3:0	I2C FILTER DEPTH	RW	0xE	I2C Glitch Filter Depth This field configures the maximum width of glitch pulses on the SCL and SDA inputs that will be rejected. Units are 5 nanoseconds.

**Register Maps (continued)**
**Table 12. Serial Control Bus Registers (continued)**

ADD (hex)	Register Name	Bit(s)	Function	Type	Default Value (hex)	Description
0x06	I2C Control 2	7	FORWARD CHANNEL SEQUENCE ERROR	R	0	Control Channel Sequence Error Detected This bit indicates a sequence error has been detected in forward control channel. If this bit is set, an error may have occurred in the control channel operation.
		6	CLEAR SEQUENCE ERROR	RW	0	Clears the Sequence Error Detect bit
		5	RESERVED	R	0	Reserved.
		4:3	SDA Output Delay	RW	0	SDA Output Delay This field configures output delay on the SDA output. Setting this value will increase output delay in units of 50ns. Nominal output delay values for SCL to SDA are: 00 : 250ns 01: 300ns 10: 350ns 11: 400ns
		2	LOCAL WRITE DISABLE	RW	0	Disable Remote Writes to Local Registers Setting this bit to a 1 will prevent remote writes to local device registers from across the control channel. This prevents writes to the Deserializer registers from an I2C master attached to the Serializer. Setting this bit does not affect remote access to I2C slaves at the Deserializer.
		1	I2C BUS TIMER SPEEDUP	RW	0	Speed up I2C Bus Watchdog Timer 1: Watchdog Timer expires after approximately 50 microseconds 0: Watchdog Timer expires after approximately 1 second.
0x07	REMOTE ID	7:1	REMOTE ID (Loaded from remote SER)	RW	0x00	7-bit Serializer Device ID Configures the I2C Slave ID of the remote Serializer. A value of 0 in this field disables I2C access to the remote Serializer. This field is automatically loaded from the Serializer once RX Lock has been detected. Software may overwrite this value, but should also assert the FREEZE DEVICE ID bit to prevent loading by the Bidirectional Control Channel.
		0	FREEZE DEVICE ID	RW	0	Freeze Serializer Device ID Prevent auto-loading of the Serializer Device ID from the Forward Channel. The ID will be frozen at the value written.
0x08	SlaveID[0]	7:1	SLAVE ID0	RW	0	7-bit Remote Slave Device ID 0 Configures the physical I2C address of the remote I2C Slave device attached to the remote Serializer. If an I2C transaction is addressed to the Slave Alias ID0, the transaction will be remapped to this address before passing the transaction across the Bidirectional Control Channel to the Serializer.
		0	RESERVED	RW	0	Reserved.
0x09	SlaveID[1]	7:01	SLAVE ID1	RW	0	7-bit Remote Slave Device ID 1 Configures the physical I2C address of the remote I2C Slave device attached to the remote Serializer. If an I2C transaction is addressed to the Slave Alias ID1, the transaction will be remapped to this address before passing the transaction across the Bidirectional Control Channel to the Serializer.
		0	RESERVED	RW	0	Reserved.



**Register Maps (continued)**
**Table 12. Serial Control Bus Registers (continued)**

ADD (hex)	Register Name	Bit(s)	Function	Type	Default Value (hex)	Description
0x0A	SlaveID[2]	7:1	SLAVE ID2	RW	0	7-bit Remote Slave Device ID 2 Configures the physical I2C address of the remote I2C Slave device attached to the remote Serializer. If an I2C transaction is addressed to the Slave Alias ID2, the transaction will be remapped to this address before passing the transaction across the Bidirectional Control Channel to the Serializer.
		0	RESERVED	RW	0	Reserved.
0x0B	SlaveID[3]	7:1	SLAVE ID3	RW	0	7-bit Remote Slave Device ID 3 Configures the physical I2C address of the remote I2C Slave device attached to the remote Serializer. If an I2C transaction is addressed to the Slave Alias ID3, the transaction will be remapped to this address before passing the transaction across the Bidirectional Control Channel to the Serializer.
		0	RESERVED	RW	0	Reserved.
0x0C	SlaveID[4]	7:1	SLAVE ID4	RW	0	7-bit Remote Slave Device ID 4 Configures the physical I2C address of the remote I2C Slave device attached to the remote Serializer. If an I2C transaction is addressed to the Slave Alias ID4, the transaction will be remapped to this address before passing the transaction across the Bidirectional Control Channel to the Serializer.
		0	RESERVED	RW	0	Reserved.
0x0D	SlaveID[5]	7:1	SLAVE ID5	RW	0	7-bit Remote Slave Device ID 5 Configures the physical I2C address of the remote I2C Slave device attached to the remote Serializer. If an I2C transaction is addressed to the Slave Alias ID5, the transaction will be remapped to this address before passing the transaction across the Bidirectional Control Channel to the Serializer.
		0	RESERVED	RW	0	Reserved.
0x0E	SlaveID[6]	7:1	SLAVE ID6	RW	0	7-bit Remote Slave Device ID 6 Configures the physical I2C address of the remote I2C Slave device attached to the remote Serializer. If an I2C transaction is addressed to the Slave Alias ID6, the transaction will be remapped to this address before passing the transaction across the Bidirectional Control Channel to the Serializer.
		0	RESERVED	RW	0	Reserved.
0x0F	SlaveID[7]	7:1	SLAVE ID7	RW	0	7-bit Remote Slave Device ID 7 Configures the physical I2C address of the remote I2C Slave device attached to the remote Serializer. If an I2C transaction is addressed to the Slave Alias ID7, the transaction will be remapped to this address before passing the transaction across the Bidirectional Control Channel to the Serializer.
		0	RESERVED	RW	0	Reserved.
0x10	SlaveAlias[0]	7:1	SLAVE ALIAS ID0	RW	0	7-bit Remote Slave Device Alias ID 0 Configures the decoder for detecting transactions designated for an I2C Slave device attached to the remote Serializer. The transaction will be remapped to the address specified in the Slave ID0 register. A value of 0 in this field disables access to the remote I2C Slave.
		0	RESERVED		0	Reserved.
0x11	SlaveAlias[1]	7:1	SLAVE ALIAS ID1	RW	0	7-bit Remote Slave Device Alias ID 1 Configures the decoder for detecting transactions designated for an I2C Slave device attached to the remote Serializer. The transaction will be remapped to the address specified in the Slave ID1 register. A value of 0 in this field disables access to the remote I2C Slave.
		0	RESERVED		0	Reserved.

**Register Maps (continued)**
**Table 12. Serial Control Bus Registers (continued)**

ADD (hex)	Register Name	Bit(s)	Function	Type	Default Value (hex)	Description
0x12	SlaveAlias[2]	7:1	SLAVE ALIAS ID2	RW	0	7-bit Remote Slave Device Alias ID 2 Configures the decoder for detecting transactions designated for an I2C Slave device attached to the remote Serializer. The transaction will be remapped to the address specified in the Slave ID2 register. A value of 0 in this field disables access to the remote I2C Slave.
		0	RESERVED		0	Reserved.
0x13	SlaveAlias[3]	7:1	SLAVE ALIAS ID3	RW	0	7-bit Remote Slave Device Alias ID 3 Configures the decoder for detecting transactions designated for an I2C Slave device attached to the remote Serializer. The transaction will be remapped to the address specified in the Slave ID3 register. A value of 0 in this field disables access to the remote I2C Slave.
		0	RESERVED		0	Reserved.
0x14	SlaveAlias[4]	7:1	SLAVE ALIAS ID4	RW	0	7-bit Remote Slave Device Alias ID 4 Configures the decoder for detecting transactions designated for an I2C Slave device attached to the remote Serializer. The transaction will be remapped to the address specified in the Slave ID4 register. A value of 0 in this field disables access to the remote I2C Slave.
		0	RESERVED		0	Reserved.
0x15	SlaveAlias[5]	7:1	SLAVE ALIAS ID5	RW	0	7-bit Remote Slave Device Alias ID 5 Configures the decoder for detecting transactions designated for an I2C Slave device attached to the remote Serializer. The transaction will be remapped to the address specified in the Slave ID5 register. A value of 0 in this field disables access to the remote I2C Slave.
		0	RESERVED		0	Reserved
0x16	SlaveAlias[6]	7:1	SLAVE ALIAS ID6	RW	0	7-bit Remote Slave Device Alias ID 6 Configures the decoder for detecting transactions designated for an I2C Slave device attached to the remote Serializer. The transaction will be remapped to the address specified in the Slave ID6 register. A value of 0 in this field disables access to the remote I2C Slave.
		0	RESERVED		0	Reserved.
0x17	SlaveAlias[7]	7:1	SLAVE ALIAS ID7	RW	0	7-bit Remote Slave Device Alias ID 7 Configures the decoder for detecting transactions designated for an I2C Slave device attached to the remote Serializer. The transaction will be remapped to the address specified in the Slave ID7 register. A value of 0 in this field disables access to the remote I2C Slave.
		0	RESERVED		0	Reserved.
0x18	MAILBOX_18	7:0	MAILBOX_18	RW	0	Mailbox Register This register is an unused read/write register that can be used for any purpose such as passing messages between I2C masters on opposite ends of the link.
0x19	MAILBOX_19	7:0	MAILBOX_19	RW	0x01	Mailbox Register This register is an unused read/write register that can be used for any purpose such as passing messages between I2C masters on opposite ends of the link.

**Register Maps (continued)**
**Table 12. Serial Control Bus Registers (continued)**

ADD (hex)	Register Name	Bit(s)	Function	Type	Default Value (hex)	Description
0x1A	GPIO[9] and Global GPIO Config	7	GLOBAL GPIO OUTPUT VALUE	RW	0	Global GPIO Output Value This value is output on each GPIO pin when the individual pin is not otherwise enabled as a GPIO and the global GPIO direction is Output
		6	RESERVED	RW	0	Reserved
		5	GLOBAL GPIO FORCE DIR	RW	0	The GLOBAL GPIO DIR and GLOBAL GPIO EN bits configure the pad in input direction or output direction for functional mode or GPIO mode. The GLOBAL bits are overridden by the individual GPIO DIR and GPIO EN bits. {GLOBAL GPIO DIR, GLOBAL GPIO EN} 00: Functional mode; output 10: Tri-state 01: Force mode; output 11: Force mode; input
		4	GLOBAL GPIO FORCE EN	RW	0	
		3	GPIO9 OUTPUT VALUE	RW	0	Local GPIO Output Value This value is output on the GPIO pin when the GPIO function is enabled, the local GPIO direction is Output, and remote GPIO control is disabled.
		2	RESERVED	RW	0	Reserved
		1	GPIO9 DIR	RW	0	The GPIO DIR and GPIO EN bits configure the pad in input direction or output direction for functional mode or GPIO mode. {GPIO DIR, GPIO EN} 00: Functional mode; output 10: Tri-state 01: GPIO mode; output 11: GPIO mode; input
		0	GPIO9 EN	RW	0	
0x1B	Frequency Counter	7:0	Frequency Count	RW	0	Frequency Counter control A write to this register will enable a frequency counter to count the number of pixel clock during a specified time interval. The time interval is equal to the value written multiplied by the oscillator clock period (nominally 50ns). A read of the register returns the number of pixel clock edges seen during the enabled interval. The frequency counter will freeze at 0xff if it reaches the maximum value. The frequency counter will provide a rough estimate of the pixel clock period. If the pixel clock frequency is known, the frequency counter may be used to determine the actual oscillator clock frequency.
0x1C	General Status	7:5	RESERVED	R	0	Reserved.
		4	DUAL_RX_STS	R	0	Receiver Dual Link Status: This bit indicates the current operating mode of the FPD-Link III Receive port 1: 2-lane mode active 0: 1-lane mode active
		3	I2S LOCKED	R	0	I2S LOCK STATUS 0: I2S PLL controller not locked 1: I2S PLL controller locked to input I2S clock
		2	RESERVED	R	0	Reserved.
		1	RESERVED	R	0/1	Reserved.
		0	LOCK	R	0	De-Serializer CDR, PLL's clock to recovered clock frequency 1: De-Serializer locked to recovered clock 0: De-Serializer not locked In Dual Link mode, this indicates both channels are locked.

**Register Maps (continued)**
**Table 12. Serial Control Bus Registers (continued)**

ADD (hex)	Register Name	Bit(s)	Function	Type	Default Value (hex)	Description
0x1D	GPIO0 Config					GPIO0 and D_GPIO0 Configuration If PORT1_SEL is set, this register controls the D_GPIO0 pin
		7:4	Rev-ID	R		Revision ID
		3	GPIO0 OUTPUT VALUE D_GPIO0 OUTPUT VALUE	RW	0	Local GPIO Output Value This value is output on the GPIO pin when the GPIO function is enabled, the local GPIO direction is Output, and remote GPIO control is disabled.
		2	GPIO0 REMOTE ENABLE D_GPIO0 REMOTE ENABLE	RW	0	Remote GPIO Control 1: Enable GPIO control from remote Serializer. The GPIO pin will be an output, and the value is received from the remote Serializer. 0: Disable GPIO control from remote Serializer.
		1	GPIO0 DIR D_GPIO0 DIR	RW	0	The GPIO DIR and GPIO EN configures the pad in input direction or output direction for functional mode or GPIO mode. {GPIO DIR, GPIO EN} 00: Functional mode; output 10: Tri-state 01: GPIO mode; output 11: GPIO mode; input
		0	GPIO0 EN D_GPIO0 EN	RW	0	
0x1E	GPIO1_2 Config					GPIO1/GPIO2 and D_GPIO1/D_GPIO2 Configuration If PORT1_SEL is set, this register controls the D_GPIO1 and D_GPIO2 pins
		7	GPIO2 OUTPUT VALUE D_GPIO2 OUTPUT VALUE	RW	0	Local GPIO Output Value This value is output on the GPIO pin when the GPIO function is enabled, the local GPIO direction is Output, and remote GPIO control is disabled.
		6	GPIO2 REMOTE ENABLE D_GPIO2 REMOTE ENABLE	RW	0	Remote GPIO Control 1: Enable GPIO control from remote Serializer. The GPIO pin will be an output, and the value is received from the remote Serializer. 0: Disable GPIO control from remote Serializer.
		5	GPIO2 DIR D_GPIO2 DIR	RW	0	The GPIO DIR and GPIO EN configures the pad in input direction or output direction for functional mode or GPIO mode. {GPIO DIR, GPIO EN} 00: Functional mode; output 10: Tri-state 01: GPIO mode; output 11: GPIO mode; input
		4	GPIO2 EN D_GPIO2 EN	RW	0	
		3	GPIO1 OUTPUT VALUE D_GPIO1 OUTPUT VALUE	RW	0	Local GPIO Output Value This value is output on the GPIO pin when the GPIO function is enabled, the local GPIO direction is Output, and remote GPIO control is disabled.
		2	GPIO1 REMOTE ENABLE D_GPIO1 REMOTE ENABLE	RW	0	Remote GPIO Control 1: Enable GPIO control from remote Serializer. The GPIO pin will be an output, and the value is received from the remote Serializer. 0: Disable GPIO control from remote Serializer.
		1	GPIO1 DIR D_GPIO1 DIR	RW	0	The GPIO DIR and GPIO EN configures the pad in input direction or output direction for functional mode or GPIO mode. {GPIO DIR, GPIO EN} 00: Functional mode; output 10: Tri-state 01: GPIO mode; output 11: GPIO mode; input
		0	GPIO1 EN D_GPIO1 EN	RW	0	

**Register Maps (continued)**
**Table 12. Serial Control Bus Registers (continued)**

ADD (hex)	Register Name	Bit(s)	Function	Type	Default Value (hex)	Description
0x1F	GPIO3 Config					GPIO3 and D_GPIO3 Configuration If PORT1_SEL is set, this register controls the D_GPIO3 pin
		7:4	RESERVED	RW	0	Reserved (No GPIO 4)
		3	GPIO3 OUTPUT VALUE D_GPIO3 OUTPUT VALUE	RW	0	Local GPIO Output Value This value is output on the GPIO pin when the GPIO function is enabled, the local GPIO direction is Output, and remote GPIO control is disabled.
		2	GPIO3 REMOTE ENABLE D_GPIO3 REMOTE ENABLE	RW	0	Remote GPIO Control 1: Enable GPIO control from remote Serializer. The GPIO pin will be an output, and the value is received from the remote Serializer. 0: Disable GPIO control from remote Serializer.
		1	GPIO3 DIR D_GPIO3 DIR	RW	0	The GPIO DIR and GPIO EN configures the pad in input direction or output direction for functional mode or GPIO mode. {GPIO DIR, GPIO EN} 00: Functional mode; output 10: Tri-state 01: GPIO mode; output 11: GPIO mode; input
		0	GPIO3 EN D_GPIO3 EN	RW	0	
0x20	GPIO5_6 Config	7	GPIO6 OUTPUT VALUE	RW	0	Local GPIO Output Value This value is output on the GPIO pin when the GPIO function is enabled, the local GPIO direction is Output, and remote GPIO control is disabled.
		6	GPIO6 REMOTE ENABLE	RW	0	Remote GPIO Control 1: Enable GPIO control from remote Serializer. The GPIO pin will be an output, and the value is received from the remote Serializer. 0: Disable GPIO control from remote Serializer.
		5	GPIO6 DIR	RW	0	The GPIO DIR and GPIO EN configures the pad in input direction or output direction for functional mode or GPIO mode. {GPIO DIR, GPIO EN} 00: Functional mode; output 10: Tri-state 01: GPIO mode; output 11: GPIO mode; input
		4	GPIO6 EN	RW	0	
		3	GPIO5 OUTPUT VALUE	RW	0	Local GPIO Output Value This value is output on the GPIO pin when the GPIO function is enabled, the local GPIO direction is Output, and remote GPIO control is disabled.
		2	GPIO5 REMOTE ENABLE	RW	0	Remote GPIO Control 1: Enable GPIO control from remote Serializer. The GPIO pin will be an output, and the value is received from the remote Serializer. 0: Disable GPIO control from remote Serializer.
		1	GPIO5 DIR	RW	0	The GPIO DIR and GPIO EN configures the pad in input direction or output direction for functional mode or GPIO mode. {GPIO DIR, GPIO EN} 00: Functional mode; output 10: Tri-state 01: GPIO mode; output 11: GPIO mode; input
		0	GPIO5 EN	RW	0	

**Register Maps (continued)**
**Table 12. Serial Control Bus Registers (continued)**

ADD (hex)	Register Name	Bit(s)	Function	Type	Default Value (hex)	Description
0x21	GPIO7_8 Config	7	GPIO8 OUTPUT VALUE	RW	0	Local GPIO Output Value This value is output on the GPIO pin when the GPIO function is enabled, the local GPIO direction is Output, and remote GPIO control is disabled.
		6	GPIO8 REMOTE ENABLE	RW	0	Remote GPIO Control 1: Enable GPIO control from remote Serializer. The GPIO pin will be an output, and the value is received from the remote Serializer. 0: Disable GPIO control from remote Serializer.
		5	GPIO8 DIR	RW	0	The GPIO DIR and GPIO EN configures the pad in input direction or output direction for functional mode or GPIO mode. {GPIO DIR, GPIO EN} 00: Functional mode; output 10: Tri-state 01: GPIO mode; output 11: GPIO mode; input
		4	GPIO8 EN	RW	0	
		3	GPIO7 OUTPUT VALUE	RW	0	Local GPIO Output Value This value is output on the GPIO pin when the GPIO function is enabled, the local GPIO direction is Output, and remote GPIO control is disabled.
		2	GPIO7 REMOTE ENABLE	RW	0	Remote GPIO Control 1: Enable GPIO control from remote Serializer. The GPIO pin will be an output, and the value is received from the remote Serializer. 0: Disable GPIO control from remote Serializer.
		1	GPIO7 DIR	RW	0	The GPIO DIR and GPIO EN configures the pad in input direction or output direction for functional mode or GPIO mode. {GPIO DIR, GPIO EN} 00: Functional mode; output 10: Tri-state 01: GPIO mode; output 11: GPIO mode; input
		0	GPIO7 EN	RW	0	

**Register Maps (continued)**
**Table 12. Serial Control Bus Registers (continued)**

ADD (hex)	Register Name	Bit(s)	Function	Type	Default Value (hex)	Description
0x22	Datapath Control	7	OVERRIDE FC CONFIG	RW	0	1: Disable loading of this register from the forward channel, keeping locally written values intact 0: Allow forward channel loading of this register
		6	PASS RGB (Loaded from remote SER)	RW	0	Setting this bit causes RGB data to be sent independent of DE. This allows operation in systems which may not use DE to frame video data or send other data when DE is deasserted. Note that this bit prevents HDCP operation and blocks packetized audio. This bit has no effect when paired with a serializer that does not support HDCP. 1: Pass RGB independent of DE 0: Normal operation Note: this bit is automatically loaded from the remote serializer unless bit 7 of this register is set.
		5	DE POLARITY (Loaded from remote SER)	RW	0	This bit indicates the polarity of the DE (Data Enable) signal. 1: DE is inverted (active low, idle high) 0: DE is positive (active high, idle low) Note: this bit is automatically loaded from the remote serializer unless bit 7 of this register is set.
		4	I2S_RPTR_REG EN (Loaded from remote SER)	RW	0	Regenerate I2S Data from Repeater I2S pins. 1: Don't output packetized audio data on RGB video output pins 0: Output packetized audio on RGB video output pins (Default). Note: this bit is automatically loaded from the remote serializer unless bit 7 of this register is set.
		3	I2S 4-CHANNEL ENABLE OVERRIDE (Loaded from remote SER)	RW	0	1: Set I2S 4-Channel Enable from bit of this register 0: Set I2S 4-Channel disabled Note: this bit is automatically loaded from the remote serializer unless bit 7 of this register is set.
		2	18-BIT VIDEO SELECT (Loaded from remote SER)	RW	0	1: Select 18-bit video mode 0: Select 24-bit video mode Note: this bit is automatically loaded from the remote serializer unless bit 7 of this register is set.
		1	I2S TRANSPORT SELECT (Loaded from remote SER)	RW	0	1: Enable I2S In-Band Transport 0: Enable I2S Data Island Transport Note: this bit is automatically loaded from the remote serializer unless bit 7 of this register is set.
		0	I2S 4-CHANNEL ENABLE (Loaded from remote SER)	RW	0	I2S 4-Channel Enable 1: Enable I2S 4-Channel 0: Disable I2S 4-Channel Note: this bit is automatically loaded from the remote serializer unless bit 7 of this register is set.

**Register Maps (continued)**
**Table 12. Serial Control Bus Registers (continued)**

ADD (hex)	Register Name	Bit(s)	Function	Type	Default Value (hex)	Description
0x23	RX Mode Status	7	RESERVED	RW	0	Reserved
		6	BC_FREQ_SELECT	RW	0	Back Channel Frequency Select 0: Divide-by-4 frequency based on the internal oscillator 1: Divide-by-2 frequency based on the internal oscillator This bit will be ignored if BC_HIGH_SPEED is set to a 1. Note that changing this setting will result in some errors on the back channel for a short period of time. If set over the control channel, the Serializer should first be programmed to Auto-Ack operation (Serializer register 0x03, bit 5) to avoid a control channel timeout due to lack of response from the Deserializer.
		5	AUTO_I2S	RW	1	Auto I2S Determine I2S mode from the AUX data codes.
		4	BC_HS_CTL	RW	0	Back-Channel High-Speed control Enables high-speed back-channel at 20Mbps. This bit will override the BC_FREQ_SELECT setting. Note that changing this setting will result in some errors on the back channel for a short period of time. If set over the control channel, the Serializer should first be programmed to Auto-Ack operation (Serializer register 0x03, bit 5) to avoid a control channel timeout due to lack of response from the Deserializer. BC_HIGH_SPEED is loaded from the MODE_SEL1 pin strap options.
		3	COAX_MODE	RW	0	Coax Mode Configures the FPD3 Receiver for operation over Coax or STP cabling: 0 : Shielded Twisted pair (STP) 1 : Coax Coax Mode is loaded from the MODE_SEL1 pin strap options.
		2	REPEATER_MODE	RW	0	Repeater Mode Indicates device is strapped to repeater mode. Repeater Mode is loaded from the MODE_SEL1 pin strap options.
		1	RESERVED	RW	0	Reserved
		0	RESERVED	RW	0	Reserved



**Register Maps (continued)**
**Table 12. Serial Control Bus Registers (continued)**

ADD (hex)	Register Name	Bit(s)	Function	Type	Default Value (hex)	Description
0x24	BIST Control	7:6	BIST_OUT_MODE	RW	0	BIST Output Mode 00 : No toggling 01 : Alternating 1/0 toggling 1x : Toggle based on BIST data
		5:4	AUTO_OSC_FREQ	RW	0	When register 0x02 bit 5 (AUTO)CLOCK_EN is set, this field controls the nominal frequency of the oscillator-based receive clock. 00: 50 MHz 01: 25 MHz 10: 10 MHz 11: Reserved
		3	BIST PIN CONFIG	RW	1	Bist Configured through Pin. 1: Bist configured through pin. 0: Bist configured through bits 2:0 in this register
		2:1	BIST CLOCK SOURCE	RW	0	BIST Clock Source This register field selects the BIST Clock Source at the Serializer. These register bits are automatically written to the CLOCK SOURCE bits (register offset 0x14) in the Serializer after BIST is enabled. See the appropriate Serializer register descriptions for details. 00: External Pixel Clock 01: Internal Pixel Clock 1x: Internal Pixel Clock
		0	BIST_EN	RW	0	BIST Control 1: Enabled 0: Disabled
0x25	BIST ERROR COUNT	7:0	BIST ERROR COUNT	R	0	Bist Error Count Returns BIST error count for selected port. Port selected is based on the PORT_SEL control in the DUAL_RX_CTL register 0x34 [1:0].
0x26	SCL High Time	7:0	SCL HIGH TIME	RW	0x83	I2C Master SCL High Time This field configures the high pulse width of the SCL output when the De-Serializer is the Master on the local I2C bus. Units are 50 ns for the nominal oscillator clock frequency. The default value is set to provide a minimum 5us SCL high time with the internal oscillator clock running at 26MHz rather than the nominal 20MHz.
0x27	SCL Low Time	7:0	SCL LOW TIME	RW	0x84	I2C SCL Low Time This field configures the low pulse width of the SCL output when the De-Serializer is the Master on the local I2C bus. This value is also used as the SDA setup time by the I2C Slave for providing data prior to releasing SCL during accesses over the Bidirectional Control Channel. Units are 50 ns for the nominal oscillator clock frequency. The default value is set to provide a minimum 5us SCL low time with the internal oscillator clock running at 26MHz rather than the nominal 20MHz.

**Register Maps (continued)**
**Table 12. Serial Control Bus Registers (continued)**

ADD (hex)	Register Name	Bit(s)	Function	Type	Default Value (hex)	Description
0x28	Datapath Control 2	7	OVERRIDE FC CONFIG	RW	0	1: Disable loading of this register from the forward channel, keeping locally written values intact 0: Allow forward channel loading of this register
		6	RESERVED	RW	0	Reserved
		5	VIDEO_DISABLED (Loaded from remote SER)	RW	0	Forward channel video disabled 0 : Normal operation 1 : Video is disabled, control channel is enabled This is a status bit only, indicating the forward channel is not sending active video. In this mode, the control channel and GPIO functions are enabled. Setting OVERRIDE_FC_CONFIG will prevent this bit from changing.
		4	DUAL_LINK (Loaded from remote SER)	R		1: Dual Link mode enabled 0: Single Link mode enabled This bit will always be loaded from forward channel and cannot be written locally. To force DUAL_LINK receive mode, use the RX_PORT_SEL register (address 0x34)
		3	ALTERNATE I2S ENABLE (Loaded from remote SER)	RW	0	1: Enable alternate I2S output on GPIO1 (word clock) and GPIO0 (data) 0: Normal Operation
		2	I2S DISABLED (Loaded from remote SER)	RW	0	1: I2S DISABLED 0: Normal Operation
		1	28BIT VIDEO (Loaded from remote SER)	RW	0	1: 28 bit Video enable. i.e. HS, VS, DE are present in forward channel. 0: Normal Operation
		0	I2S SURROUND (Loaded from remote SER)	RW	0	1: I2S Surround enabled 0: I2S Surround disabled
0x2B	I2S Control	7:4	RESERVED	RW	0	Reserved
		3	I2S FIFO OVERRUN STATUS	R	0	I2S FIFO Overrun Status
		2	I2S FIFO UNDERRUN STATUS	R	0	I2S FIFO Underrun Status
		1	I2S FIFO ERROR RESET	RW	0	I2S Fifo Error Reset 1: Clears FIFO Error
		0	I2S DATA FALLING EDGE	RW	0	I2S Clock Edge Select 1: I2S Data is strobed on the Rising Clock Edge. 0: I2S Data is strobed on the Falling Clock Edge.
0x2E	PCLK Test Mode	7	EXTERNAL PCLK	RW	0	Select pixel clock from BISTC input
		6:0	RESERVED	RW	0	Reserved

**Register Maps (continued)**
**Table 12. Serial Control Bus Registers (continued)**

ADD (hex)	Register Name	Bit(s)	Function	Type	Default Value (hex)	Description
0x34	DUAL_RX_CTL	7	RESERVED	R	0	Reserved
		6	RX_LOCK_MODE	RW	0	RX Lock Mode: Determines operating conditions for indication of RX_LOCK and generation of video data. 0 : RX_LOCK asserted only when receiving active video (Forward channel VIDEO_DISABLED bit is 0) 1 : RX_LOCK asserted when device is linked to a Serializer even if active video is not being sent. This allows indication of valid link where Bidirectional Control Channel is enabled, but Deserializer is not receiving Audio/Video data.
		5	RAW_2ND_BC	RW	0	Enable Raw Secondary Back channel If this bit is set to a 1, the secondary back channel will operate in a raw mode, passing D_GPIO0 from the Deserializer to the Serializer, without any oversampling or filtering.
		4:3	FPD3 INPUT MODE	RW	0	FPD-Link III Input Mode Determines operating mode of FPD-Link III Receive interface 00: Auto-detect based on received data 01: Forced Mode: 2-lane 10: Forced Mode: 1-lane, primary input 11: Forced Mode: 1-lane, secondary input
		2	RESERVED	RW	0	Reserved
		1	PORT1_SEL	RW	0	Selects Port 1 for Register Access from primary I2C Address For writes, port1 registers and shared registers will both be written. For reads, port1 registers and shared registers will be read. This bit must be cleared to read port0 registers.
		0	PORT0_SEL	RW	1	Selects Port 0 for Register Access from primary I2C Address For writes, port0 registers and shared registers will both be written. For reads, port0 registers and shared registers will both be read. Note that if PORT1_SEL is also set, then port1 registers will be read.
0x35	AEQ TEST					AEQ Test register If PORT1_SEL is set, this register sets port1 AEQ controls
		7	RESERVED	RW	0	Reserved
		6	AEQ_RESTART	RW	0	Set high to restart AEQ adaptation from initial value. Method is write HIGH then write LOW - not self clearing. Adaption will be restarted on both ports.
		5	OVERVERRIDE_AEQ_FLOOR	RW	0	Enable operation of SET_AEQ_FLOOR
		4	SET_AEQ_FLOOR	RW	0	AEQ adaptation starts from a pre-set floor value rather than from zero - recommended for long cable situations
		3:0	RESERVED	RW	0x0	Reserved

**Register Maps (continued)**
**Table 12. Serial Control Bus Registers (continued)**

ADD (hex)	Register Name	Bit(s)	Function	Type	Default Value (hex)	Description
0x37	MODE_SEL	7	MODE_SEL1 DONE	RW	0	MODE_SEL1 Done: 0: indicates the MODE_SEL1 decode has not been latched into the MODE_SEL1 status bits. 1: indicates the MODE_SEL1 decode has completed and latched into the MODE_SEL1 status bits.
		6:4	MODE_SEL1	RW	0	MODE_SEL1 Decode 3-bit decode from MODE_SEL1 pin, see MODE_SEL1 table first column "#" for mode selection: 000: CSi0 / 5 Mbps / STP (#1 on MODE_SEL1) 001: CSi0 / 5 Mbps / coax (#2 on MODE_SEL1) 010: CSi0 / 20 Mbps / STP (#3 on MODE_SEL1) 011: CSi0 / 20 Mbps / coax (#4 on MODE_SEL1) 100: CSi1 / 5 Mbps / STP (#5 on MODE_SEL1) 101: CSi1 / 5 Mbps / coax (#6 on MODE_SEL1) 110: CSi1 / 20 Mbps / STP (#7 on MODE_SEL1) 111: CSi1 / 20 Mbps / coax (#8 on MODE_SEL1) <i>Note: 0x37[6] is the MSB; 0x37[4] is the LSB</i>
		3	MODE_SELO DONE	RW	0	MODE_SELO Done: 0: indicates the MODE_SELO decode has not been latched into the MODE_SELO status bits. 1: indicates the MODE_SELO decode has completed and latched into the MODE_SELO status bits.
		2:0	MODE_SELO	RW	0	MODE_SELO Decode 3-bit decode from MODE_SELO pin, see MODE_SELO table first column "#" for mode selection: 000: 4 data lanes, 1 CSI port active .....Active CSI port determined by MODE_SEL1 CSI_SEL bit. ..... (#1 on MODE_SELO) 001: 4 data lanes, both CSI ports active .....overrides MODE_SEL1. (#2 on MODE_SELO) 010: 2 data lanes, 1 CSI port active .....Active CSI port determined by MODE_SEL1 CSI_SEL bit. ..... (#3 on MODE_SELO) 011: 2 data lanes, both CSI port active .....overrides MODE_SEL1. (#4 on MODE_SELO) 100: RESERVED (#5 on MODE_SELO) 101: RESERVED (#6 on MODE_SELO) 110: RESERVED (#7 on MODE_SELO) 111: RESERVED (#8 on MODE_SELO) <i>Note: 0x37[2] is the MSB; 0x37[0] is the LSB</i>
0x3A	I2S_DIVSEL	7	reg_ov_mdiv	RW	0x0	0: No override for MCLK divider 1: Override divider select for MCLK
		6:4	reg_mdiv	RW	0x0	Divide ratio select for VCO output (32*REF/M) 000: Divide by 32 (=REF/M) 001: Divide by 16 (=2*REF/M) 010: Divide by 8 (=4*REF/M) 011: Divide by 4 (=8*REF/M) 100: Reserved 101: Divide by 2 (=16*REF/M) 110: Reserved 111: Divide by 1 (32*REF/M)
		3	RESERVED	R	0x0	
		2	reg_ov_mselect	RW	0x0	0: Divide ratio of reference clock VCO selected by PLL-SM 1: Override divide ratio of clock to VCO
		1:0	reg_mselect	RW	0x0	Divide ratio select for VCO input (M) 00: Divide by 1 01: Divide by 2 10: Divide by 4 11: Divide by 8

**Register Maps (continued)**
**Table 12. Serial Control Bus Registers (continued)**

ADD (hex)	Register Name	Bit(s)	Function	Type	Default Value (hex)	Description
0x41	LINK ERROR COUNT	7:5	RESERVED	RW	0	Reserved
		4	LINK ERROR COUNT ENABLE	RW	0	Enable serial link data integrity error count 1: Enable error count 0: DISABLE
		3:0	LINK ERROR COUNT	RW	0x3	Link error count threshold. Counter is pixel clock based. clk0, clk1 and DCA are monitored for link errors, if error count is enabled, deserializer loose lock once error count reaches threshold. If disabled deserializer loose lock with one error.
0x43	HSCC_CONTROL	7:5	RESERVED	RW	0	Reserved
		4	SPI_MISO_MODE	RW	0	SPI MISO pin mode during Reverse SPI mode During Reverse SPI mode, SPI_MISO is typically an output signal. For bused SPI applications, it may be necessary to tri-state the SPI_MISO output if the device is not selected (SPI_SS = 0). 0 : Always enable SPI_MISO output driver 1 : Tri-state SPI_MISO output if SPI_SS is not asserted (low)
		3	SPI_CPOL	RW	0	SPI Clock Polarity Control 0 : SPI Data driven on Falling clock edge, sampled on Rising clock edge 1 : SPI Data driven on Rising clock edge, sampled on Falling clock edge
		2:0	HSCC_MODE	RW	0	High-Speed Control Channel Mode Enables high-speed modes for the secondary link back-channel, allowing higher speed signaling of GPIOs or SPI interface: These bits indicates the High Speed Control Channel mode of operation: 000: Normal frame, GPIO mode 001: High Speed GPIO mode, 1 GPIO 010: High Speed GPIO mode, 2 GPIOs 011: High Speed GPIO mode: 4 GPIOs 100: Reserved 101: Reserved 110: High Speed, Forward Channel SPI mode 111: High Speed, Reverse Channel SPI mode
0x44	ADAPTIVE EQ BYPASS					Adaptive Equalizer Bypass register If PORT1_SEL is set, this register sets port1 AEQ controls
		7:5	EQ STAGE 1 SELECT VALUE	RW	0x3	EQ select value[5:3] - Used if adaptive EQ is bypassed.
		4	RESERVED	RW	0	Reserved
		3:1	EQ STAGE 2 SELECT VALUE	RW	0	EQ select value [2:0] - Used if adaptive EQ is bypassed.
		0	ADAPTIVE EQ BYPASS	RW	0	1: Disable adaptive EQ 0: Enable adaptive EQ
0x45	ADAPTIVE EQ MIN MAX					Adaptive Equalizer Configuration If PORT1_SEL is set, this register sets port1 AEQ configuration
		7:4	RESERVED	RW	0x08	Reserved
		3:0	ADAPTIVE EQ FLOOR VALUE	RW		When AEQ floor is enabled by mode-sel pin or register (reg_35[5:4]) the starting setting is given by this register.

**Register Maps (continued)**
**Table 12. Serial Control Bus Registers (continued)**

ADD (hex)	Register Name	Bit(s)	Function	Type	Default Value (hex)	Description
0x52	CML OUTPUT CTL1	7	CML CHANNEL SELECT 1	RW	0	Selects between PORT0 and PORT1 to output onto CMLOUT±. 0: Recovered forward channel data from RIN0± is output on CMLOUT± 1: Recovered forward channel data from RIN1± is output on CMLOUT± CMLOUT driver must be enabled by setting 0x56[3] = 1. Note: This bit must match 0x57[2:1] setting for PORT0 or PORT1.
		6:0	RESERVED	RW	0	Reserved
0x56	CML OUTPUT ENABLE	7:4	RESERVED	RW	0	Reserved
		3	CMLOUT ENABLE	RW	0	Enable CMLOUT± Loop-through Driver 0: Disabled (Default) 1: Enabled
		2:0	RESERVED	RW	0	Reserved
0x57	CML OUTPUT CTL2	7:3	RESERVED	RW	0	Reserved
		2:1	CML CHANNEL SELECT 2	RW	0	Selects between PORT0 and PORT1 to output onto CMLOUT±. 01: Recovered forward channel data from RIN0± is output on CMLOUT± 10: Recovered forward channel data from RIN1± is output on CMLOUT± CMLOUT driver must be enabled by setting 0x56[3] = 1. Note: This must match 0x52[7] setting for PORT0 or PORT1.
		0	RESERVED	RW	0	Reserved

**Register Maps (continued)**
**Table 12. Serial Control Bus Registers (continued)**

ADD (hex)	Register Name	Bit(s)	Function	Type	Default Value (hex)	Description
0x64	PGCTL	7:4	PATGEN_SEL	RW	1	<p>Fixed Pattern Select</p> <p>This field selects the pattern to output when in Fixed Pattern Mode. Scaled patterns are evenly distributed across the horizontal or vertical active regions. This field is ignored when Auto-Scrolling Mode is enabled. The following table shows the color selections in non-inverted followed by inverted color mode:</p> <p>0000: Reserved  0001: White/Black  0010: Black/White  0011: Red/Cyan  0100: Green/Magenta  0101: Blue/Yellow  0110: Horizontally Scaled Black to White/White to Black  0111: Horizontally Scaled Black to Red/White to Cyan  1000: Horizontally Scaled Black to Green/White to Magenta  1001: Horizontally Scaled Black to Blue/White to Yellow  1010: Vertically Scaled Black to White/White to Black  1011: Vertically Scaled Black to Red/White to Cyan  1100: Vertically Scaled Black to Green/White to Magenta  1101: Vertically Scaled Black to Blue/White to Yellow  1110: Custom color (or its inversion) configured in PGRS, PGGS, PGBS registers  1111: Reserved</p> <p>See TI App Note <a href="#">AN-2198</a></p>
		3	PATGEN_UNH	RW	0	<p>Enables the UNH-IOL compliance test pattern:</p> <p>0: Pattern type selected by PATGEN_SEL  1: Compliance test pattern is selected. Value of PATGEN_SEL is ignored.</p>
		2	PATGEN_COLOR	RW	0	<p>Enable Color Bars Pattern</p> <p>0: Color Bars disabled (default)  1: Color bars enabled</p> <p>Overrides the selection from bits [7:4]</p>
		1	PATGEN_VCOM_REV	RW	0	<p>Reverse the order of color bands in VCOM pattern</p> <p>0: Color sequence from top left is (YCBR) (default)  1: Color sequence from top left is (RBCY)</p>
		0	PATGEN_EN	RW	0	<p>Pattern Generator Enable:</p> <p>1: Enable Pattern Generator  0: Disable Pattern Generator</p>

**Register Maps (continued)**
**Table 12. Serial Control Bus Registers (continued)**

ADD (hex)	Register Name	Bit(s)	Function	Type	Default Value (hex)	Description
0x65	PGCFG	7:5	RESERVED	R	0	Reserved
		4	PATGEN_18B	RW	0	18-bit Mode Select: 1: Enable 18-bit color pattern generation. Scaled patterns will have 64 levels of brightness and the R, G, and B outputs use the six most significant color bits. 0: Enable 24-bit pattern generation. Scaled patterns use 256 levels of brightness. This bit has no effect in external timing mode (PATGEN_TSEL = 0).
		3	PATGEN_EXTCLK	RW	0	Select PCLK of Pattern generator 1: Selects the external pixel clock when using internal timing. 0: Selects the internal divided clock when using internal timing. This bit has no effect in external timing mode (PATGEN_TSEL = 0).
		2	PATGEN_TSEL	RW	0	Timing Select Control: 1: The Pattern Generator creates its own video timing as configured in the Pattern Generator Total Frame Size, Active Frame Size, Horizontal Sync Width, Vertical Sync Width, Horizontal Back Porch, Vertical Back Porch, and Sync Configuration registers. 0: the Pattern Generator uses external video timing from the pixel clock, Data Enable, Horizontal Sync, and Vertical Sync signals.
		1	PATGEN_INV	RW	0	Enable Inverted Color Patterns: 1: Invert the color output. 0: Do not invert the color output.
		0	PATGEN_ASCRL	RW	0	Auto-Scroll Enable: 1: The Pattern Generator will automatically move to the next enabled pattern after the number of frames specified in the Pattern Generator Frame Time (PGFT) register. 0: The Pattern Generator retains the current pattern.
0x66	PGIA	7:0	PATGEN_IA	RW	0	Indirect Address: This 8-bit field sets the indirect address for accesses to indirectly-mapped registers. It should be written prior to reading or writing the Pattern Generator Indirect Data register. See TI App Note <a href="#">AN-2198</a> .
0x67	PGID	7:0	PATGEN_ID	RW	0	Indirect Data: When writing to indirect registers, this register contains the data to be written. When reading from indirect registers, this register contains the readback value. See TI App Note <a href="#">AN-2198</a> .
0x68	PGDBG	7:4	RESERVED	RW	0	Reserved
		3	PATGEN_BIST_EN	RW	0	Pattern Generator BIST Enable: Enables Pattern Generator in BIST mode. Pattern Generator will compare received video data with local generator pattern. Upstream device must be programmed to the same pattern.
		2:0	RESERVED	RW	0	Reserved
0x69	PGTSTDAT	7	PATGEN_BIST_ERR	R	0	Pattern Generator BIST Error Flag During Pattern Generator BIST mode, this bit indicates if the BIST engine has detected errors. If the BIST Error Count (available in the Pattern Generator indirect registers) is non-zero, this flag will be set.
		6:0	RESERVED	R	0	



**Register Maps (continued)**
**Table 12. Serial Control Bus Registers (continued)**

ADD (hex)	Register Name	Bit(s)	Function	Type	Default Value (hex)	Description
0x6A	CSICFG0	7:6	RESERVED	RW	00	Reserved
		5:4	LANE_CNT	RW	00	Setup number of data lanes for the CSI ports. 00/01: 4 data lanes 10: 2 data lanes
		3	ULPM	RW	0	When set, put the data lanes in ultra-low power mode (LP00) by sending out a LP signalling sequence.
		2	ULPS	RW	0	When set with ULPM, put the clock lane into ultra-low power mode. No effect if ULPM is not set.
		1	CONTS_CLK	RW	0	When set, keep the clock lane running (in HS mode) during line blank (DE=0) and frame black (VS not active)
		0	CSI_DIS	RW	0	When set, disable the CSI state machine. Function as a soft reset.
0x6B	CSICFG1	7:4	OFMT	RW	0000	Program the output CSI data formats 0000: RGB888 0001: RGB666 0010: RGB565 0011: YUV420 Legacy 0100: YUV420 0101: YUV422_8 0110: RAW8 0111: RAW10 1000: RAW12 1001: YUV420 (CSPS)
		3:2	IFMT	RW	00	Program the input data format in HDMI terminology 00: RGB444 01: YUV422 10: YUV444 11: RAW
		1	INV_VS	RW	0	When set, the VS received from the digital receiver will be inverted. Because the CSI logic works on active-high VS, this bit is typically set when the VS from the data source is active-low.
		0	INV_DE	RW	0	When set, the DE received from the digital receiver will be inverted. Because the CSI logic works on active-high DE, this bit is typically set when the DE from the data source is active-low.
0x6C	CSIIA	7:0	CSI_IA	RW	0	Indirect address port for accessing CSI registers. Refer to <a href="#">Table 13</a>
0x6D	CSIID	7:0	CSI_ID	RW	0	Indirect data port for accessing CSI registers. Refer to <a href="#">Table 13</a>
0x6E	GPI Pin Status 1	7	GPI7 Pin Status	R	0	GPI7/I2S_WC pin status
		6	GPI6 Pin Status	R	0	GPI6/I2S_DA pin status
		5	GPI5 Pin Status	R	0	GPI5/I2S_DB pin status
		4	RESERVED	R	0	Reserved for future use
		3	GPI3 Pin Status	R	0	GPI3 / I2S_DD pin status
		2	GPI2 Pin Status	R	0	GPI2 / I2S_DC pin status
		1	GPI1 Pin Status	R	0	GPI1 pin status
		0	GPI0 Pin Status	R	0	GPI0 pin status
0x6F	GPI Pin Status 2	7:1	RESERVED	R	0	Reserved for future use
		0	GPI8 Pin Status	R	0	GPI8/I2S_CLK pin status

**Register Maps (continued)**
**Table 12. Serial Control Bus Registers (continued)**

ADD (hex)	Register Name	Bit(s)	Function	Type	Default Value (hex)	Description
0xF0	RX ID	7:0	ID0	R	0x5F	First byte ID code, '_'
0xF1		7:0	ID1	R	0x55	2nd byte of ID code, 'U'
0xF2		7:0	ID2	R	0x48	3rd byte of ID code. Value will be either 'B' or 'H'. 'H' indicates an HDCP capable device.
0xF3		7:0	ID3	R	0x39	4th byte of ID code: '9'
0xF4		7:0	ID4	R	0x34	5th byte of ID code: '4'
0xF5		7:0	ID5	R	0x30	6th byte of ID code: '0'

**Table 13. CSI Indirect Register Table**

Offset (hex)	Register Name	Bit(s)	Default Value (hex)	Function
0x09	RAW_ALIGN	7:5	0x00	Reserved
		4		Raw Align. 0: RAW Output onto LSB's of RGB Bus 1: RAW Output onto MSB's of RGB Bus
		3:0		Reserved
0x13	CSI_EN_PORT0	7	0	Register Control 0 = Disable 1 = Enable
		6	0	Reserved
		5:0	0x3F	0x00 = Disable CSI Port 0 0x3F = Enable CSI Port 0
0x14	CSI_EN_PORT1	7	0	Register Control 0 = Disable 1 = Enable
		6	0	Reserved
		5:0	0x00	0x00 = Disable CSI Port 1 0x3F = Enable CSI Port 1
0x16	CSIPASS	7:3	0x02	Reserved
		2		CSI_PASS to GPIO3. Configures GPIO3 to output the PASS signal when this bit is set HIGH.
		1		CSI_PASS to GPIO0. Configures GPIO0 to output the PASS signal when this bit is set HIGH. This is the default.
		0		CSI_PASS. This bit reflects the status of the PASS signal.
0x2E	CSI_VC_ID	7:6	0x00	CSI Virtual Channel identifier. 00: CSI-2 outputs with ID as virtual channel 0. 01: CSI-2 outputs with ID as virtual channel 1. 10: CSI-2 outputs with ID as virtual channel 2. 11: CSI-2 outputs with ID as virtual channel 3.
		5:0		Reserved

## 9 Application and Implementation

---

### NOTE

Information in the following applications sections is not part of the TI component specification, and TI does not warrant its accuracy or completeness. TI's customers are responsible for determining suitability of components for their purposes. Customers should validate and test their design implementation to confirm system functionality.

---

### 9.1 Application Information

The DS90UB940-Q1 is a FPD-Link III Deserializer which, in conjunction with the DS90UB949/947-Q1 Serializers, converts 1-lane or 2-lane FPD-Link III streams into a MIPI CSI-2 interface. The Deserializer is capable of operating over cost-effective 50Ω single-ended coaxial or 100Ω differential shielded twisted-pair (STP) cables. It recovers the data from two FPD-Link III serial streams and translates it into a Camera Serial Interface (CSI-2) format compatible with MIPI DPHY/CSI-2 supporting video resolutions up to WUXGA and 1080p60 with 24-bit color depth.

### 9.2 Typical Applications

Bypass capacitors should be placed near the power supply pins. At a minimum, four (4) 10μF capacitors should be used for local device bypassing. Ferrite beads are placed on the two sets of supply pins (VDD33 and VDDIO ) for effective noise suppression. The interface to the graphics source is LVDS. The VDDIO pins may be connected to 3.3V or 1.8V. A capacitor and resistor are placed on the PDB pin to delay the enabling of the device until power is stable. See [Figure 37](#) for a typical STP connection diagram and for a typical coax connection diagram.

Typical Applications (continued)

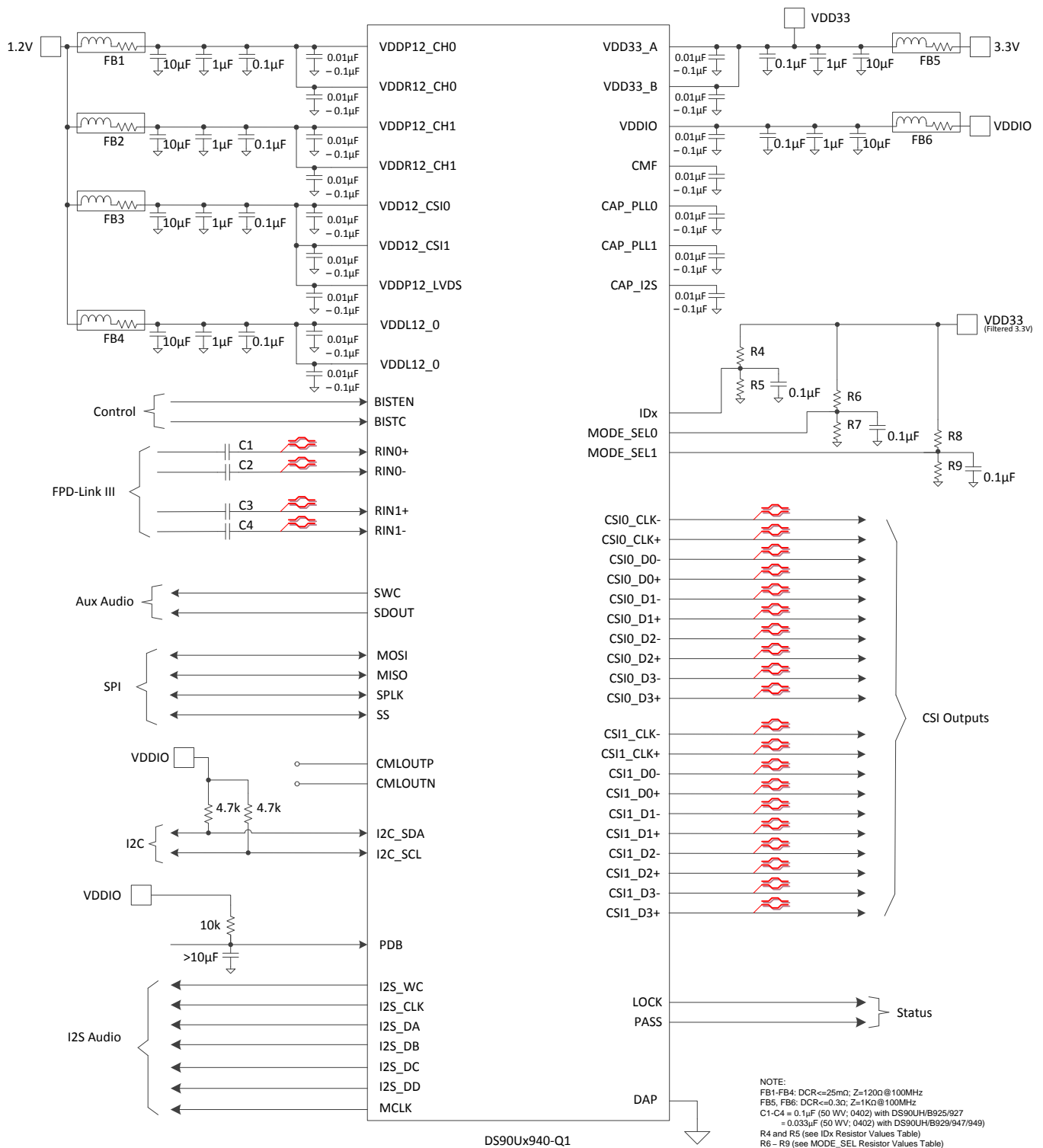

Figure 37. Typical Connection Diagram (STP)

Typical Applications (continued)

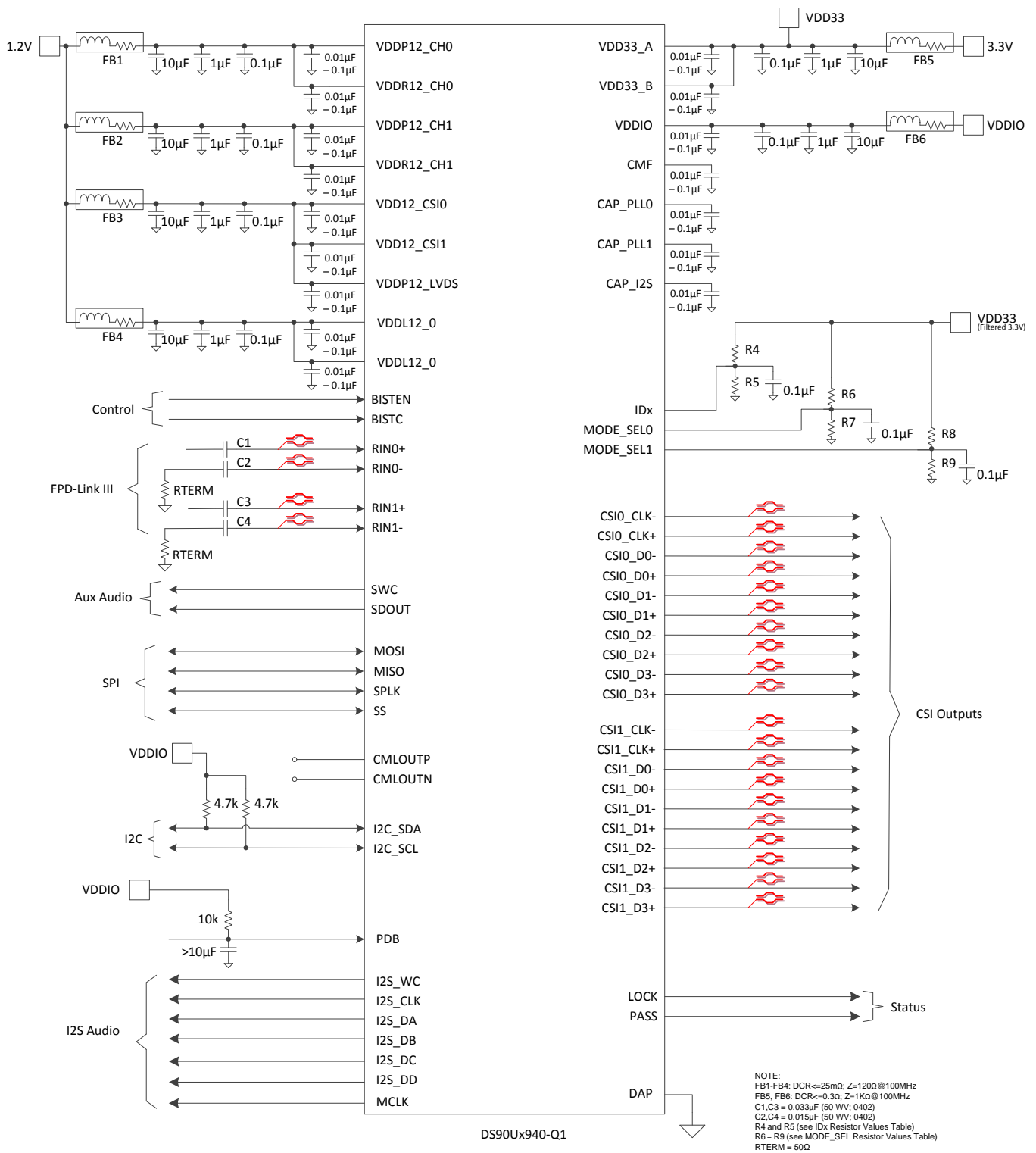

Figure 38. Typical Connection Diagram (Coax)

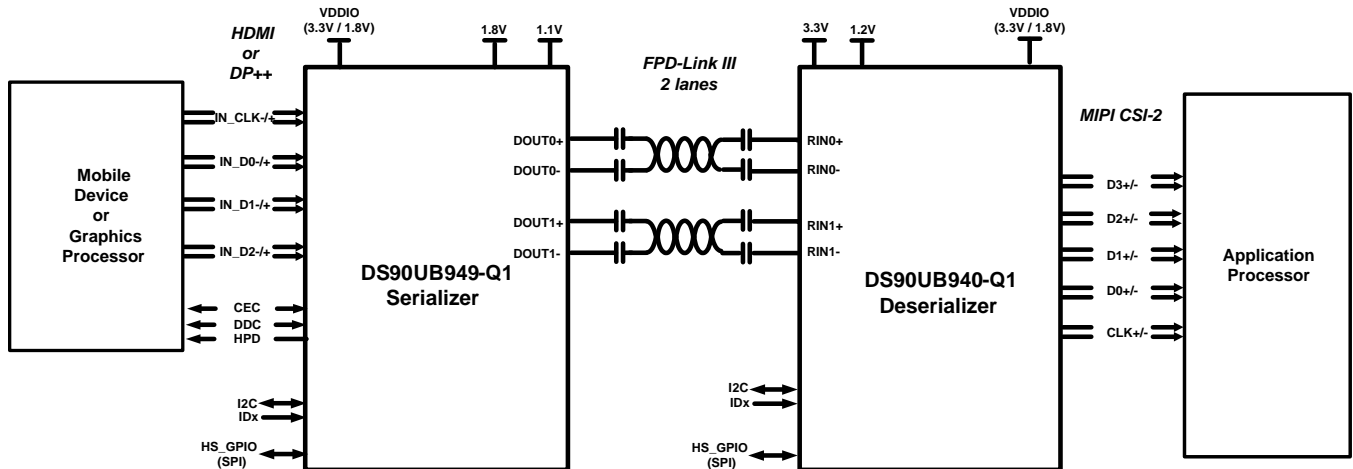

Figure 39.

9.2.1 Design Requirements

For the typical design application, use the following as input parameters.

Table 14. Design Parameters

Design Parameter	Example Value
VDDIO	1.8V or 3.3V
VDD12	1.2V
VDD33	3.3V
AC Coupling Capacitor for RIN0± and RIN1±	33 nF

The SER/DES supports only AC-coupled interconnects through an integrated DC-balanced decoding scheme. External AC coupling capacitors must be placed in series in the FPD-Link III signal path as illustrated in Figure 40. For applications utilizing single-ended 50 Ω coaxial cable, the unused data pins (RIN0-, RIN1-) should utilize a 15 nF capacitor and should be terminated with a 50 Ω resistor.

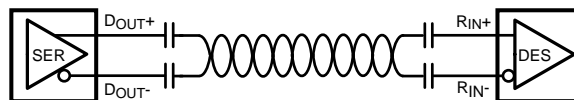

Figure 40. AC-Coupled Connection (STP)

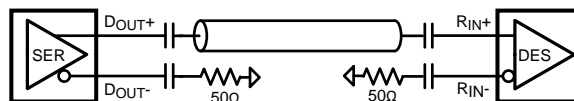

Figure 41. AC-Coupled Connection (Coaxial)

For high-speed FPD-Link III transmissions, the smallest available package should be used for the AC coupling capacitor. This will help minimize degradation of signal quality due to package parasitics. The I/O's require 33 nF AC coupling capacitors to the line.

## 9.2.2 Detailed Design Procedure

### 9.2.2.1 PCB Layout and Power System Considerations

Circuit board layout and stack-up for the LVDS serializer and deserializer devices should be designed to provide low-noise power to the device. Good layout practice will also separate high frequency or high-level inputs and outputs to minimize unwanted stray noise, feedback and interference. Power system performance may be greatly improved by using thin dielectrics (2 to 4 mil) for power / ground sandwiches. This arrangement utilizes the plane capacitance for the PCB power system and has low-inductance, which has proven effectiveness especially at high frequencies, and makes the value and placement of external bypass capacitors less critical. External bypass capacitors should include both RF ceramic and tantalum electrolytic types. RF capacitors may use values in the range of 0.01  $\mu\text{F}$  to 10  $\mu\text{F}$ . Tantalum capacitors may be in the 2.2  $\mu\text{F}$  to 10  $\mu\text{F}$  range. The voltage rating of the tantalum capacitors should be at least 5X the power supply voltage being used.

MLCC surface mount capacitors are recommended due to their smaller parasitic properties. When using multiple capacitors per supply pin, locate the smaller value closer to the pin. A large bulk capacitor is recommended at the point of power entry. This is typically in the 50  $\mu\text{F}$  to 100  $\mu\text{F}$  range and will smooth low frequency switching noise. It is recommended to connect power and ground pins directly to the power and ground planes with bypass capacitors connected to the plane with via on both ends of the capacitor. Connecting power or ground pins to an external bypass capacitor will increase the inductance of the path. A small body size X7R chip capacitor, such as 0603 or 0805, is recommended for external bypass. A small body sized capacitor has less inductance. The user must pay attention to the resonance frequency of these external bypass capacitors, usually in the range of 20MHz-30MHz. To provide effective bypassing, multiple capacitors are often used to achieve low impedance between the supply rails over the frequency of interest. At high frequency, it is also a common practice to use two vias from power and ground pins to the planes, reducing the impedance at high frequency.

Use at least a four layer board with a power and ground plane. Locate LVCMOS signals away from the LVDS lines to prevent coupling from the LVCMOS lines to the LVDS lines. Closely coupled differential lines of 100  $\Omega$  are typically recommended for LVDS interconnect. The closely coupled lines help to ensure that coupled noise will appear as common mode and thus is rejected by the receivers. The tightly coupled lines will also radiate less.

At least 32 thermal vias are necessary from the device center DAP to the ground plane. They connect the device ground to the PCB ground plane, as well as conduct heat from the exposed pad of the package to the PCB ground plane. More information on the WQFN style package, including PCB design and manufacturing requirements, is provided in TI Application Note: AN-1187.

### 9.2.2.2 CML Interconnect Guidelines

See AN-1108 and AN-905 for full details.

- Use 100 $\Omega$  coupled differential pairs
- Use the S/2S/3S rule in spacings
  - S = space between the pair
  - 2S = space between pairs
  - 3S = space to LVCMOS signal
- Minimize the number of Vias
- Use differential connectors when operating above 500Mbps line speed
- Maintain balance of the traces
- Minimize skew within the pair
- Terminate as close to the TX outputs and RX inputs as possible

Additional general guidance can be found in the LVDS Owner's Manual - available in PDF format from the Texas Instruments web site at: [SNLA187](#)

## 9.2.3 Application Performance Plots

The plots below correspond to 1080p60 video application with 2-lane FPD-Link III input and MIPI 4 lanes output.

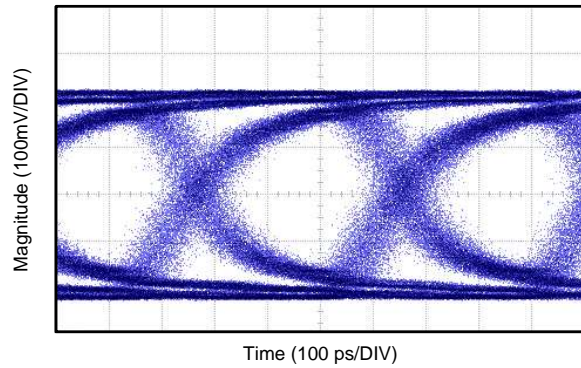

**Figure 42. Loop-through CML Output at 2.6 Gbps Serial Line Rate**

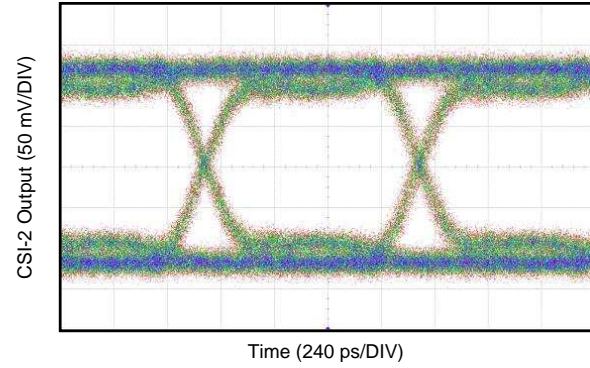

**Figure 43. CSI-2 Data Output at 1040 Mbps**

## 10 Power Supply Recommendations

This device provides separate power and ground pins for different portions of the circuit. This is done to isolate switching noise effects between different sections of the circuit. Separate planes on the PCB are typically not required. Pin Description table provide guidance on which circuit blocks are connected to which power pin pairs. In some cases, an external filter may be used to provide clean power to sensitive circuits such as PLLs.

### 10.1 Power Up Requirements and PDB Pin

When power is applied, power from the highest voltage rail to the lowest voltage rail on any of the supply pins. For 3.3V IO operation, VDDIO and VDD33 can be powered by the same supply and ramped simultaneously. The power supply ramp (VDD12, VDD33, and VDDIO) should be faster than 1.5ms with a monotonic rise. A large capacitor on the PDB pin is needed to ensure PDB arrives after all the supply pins have settled to the recommended operating voltage. When PDB pin is pulled up to VDD33, a 10 k $\Omega$  pull-up and a >10  $\mu$ F capacitor to GND are required to delay the PDB input signal rise. All inputs must not be driven until both VDD33 and VDDIO has reached steady state. Pins VDD33\_A and VDD33\_B should both be externally connected, bypassed, and driven to the same potential (they are not internally connected).

## 11 Layout

### 11.1 Layout Guidelines

Circuit board layout and stack-up for the FPD-Link III devices should be designed to provide low-noise power feed to the device. Good layout practice will also separate high frequency or high-level inputs and outputs to minimize unwanted stray noise pickup, feedback and interference. Power system performance may be greatly improved by using thin dielectrics (2 to 4 mils) for power/ground sandwiches. This arrangement provides plane capacitance for the PCB power system with low-inductance parasitics, which has proven especially effective at high frequencies, and makes the value and placement of external bypass capacitors less critical. External bypass capacitors should include both RF ceramic and tantalum electrolytic types. RF capacitors may use values in the range of 0.01  $\mu$ F to 0.1  $\mu$ F. Tantalum capacitors may be in the 2.2  $\mu$ F to 10  $\mu$ F range. Voltage rating of the tantalum capacitors should be at least 5X the power supply voltage being used.

Surface mount capacitors are recommended due to their smaller parasitics. When using multiple capacitors per supply pin, locate the smaller value closer to the pin. A large bulk capacitor is recommend at the point of power entry. This is typically in the 50  $\mu$ F to 100  $\mu$ F range and will smooth low frequency switching noise. It is recommended to connect power and ground pins directly to the power and ground planes with bypass capacitors connected to the plane with via on both ends of the capacitor. Connecting power or ground pins to an external bypass capacitor will increase the inductance of the path.



## Layout Guidelines (continued)

A small body size X7R chip capacitor, such as 0603 or 0402, is recommended for external bypass. Its small body size reduces the parasitic inductance of the capacitor. The user must pay attention to the resonance frequency of these external bypass capacitors, usually in the range of 20MHz to 30 MHz. To provide effective bypassing, multiple capacitors are often used to achieve low impedance between the supply rails over the frequency of interest. At high frequency, it is also a common practice to use two vias from power and ground pins to the planes, reducing the impedance at high frequency.

Some devices provide separate power and ground pins for different portions of the circuit. This is done to isolate switching noise effects between different sections of the circuit. Separate planes on the PCB are typically not required. Pin Description tables typically provide guidance on which circuit blocks are connected to which power pin pairs. In some cases, an external filter may be used to provide clean power to sensitive circuits such as PLLs.

Use at least a four layer board with a power and ground plane. Locate LVCMOS signals away from the CML lines to prevent coupling from the LVCMOS lines to the CML lines. Closely-coupled differential lines of 100  $\Omega$  are typically recommended for CML interconnect. The closely coupled lines help to ensure that coupled noise will appear as common-mode and thus is rejected by the receivers. The tightly coupled lines will also radiate less.

Information on the WQFN style package is provided in TI Application Note: [AN-1187](#).

### 11.2 Layout Example

Stencil parameters such as aperture area ratio and the fabrication process have a significant impact on paste deposition. Inspection of the stencil prior to placement of the WQFN package is highly recommended to improve board assembly yields. If the via and aperture openings are not carefully monitored, the solder may flow unevenly through the DAP. Stencil parameters for aperture opening and via locations are shown in [Figure 44](#):

**Table 15. No Pullback WQFN Stencil Aperture Summary**

Device	Pin Count	Mkt Dwg	PCB I/O Pad Size (mm)	PCB Pitch (mm)	PCB DAP Size (mm)	Stencil I/O Aperture (mm)	Stencil DAP Aperture (mm)	Number OF DAP Aperture Openings	Gap between DAP Aperture (Dim A mm)
DS90UB940-Q1	64	NKD	0.25 x 0.6	0.5	7.2 x 7.2	0.25 x 0.6	1.16 x 1.16	25	0.2

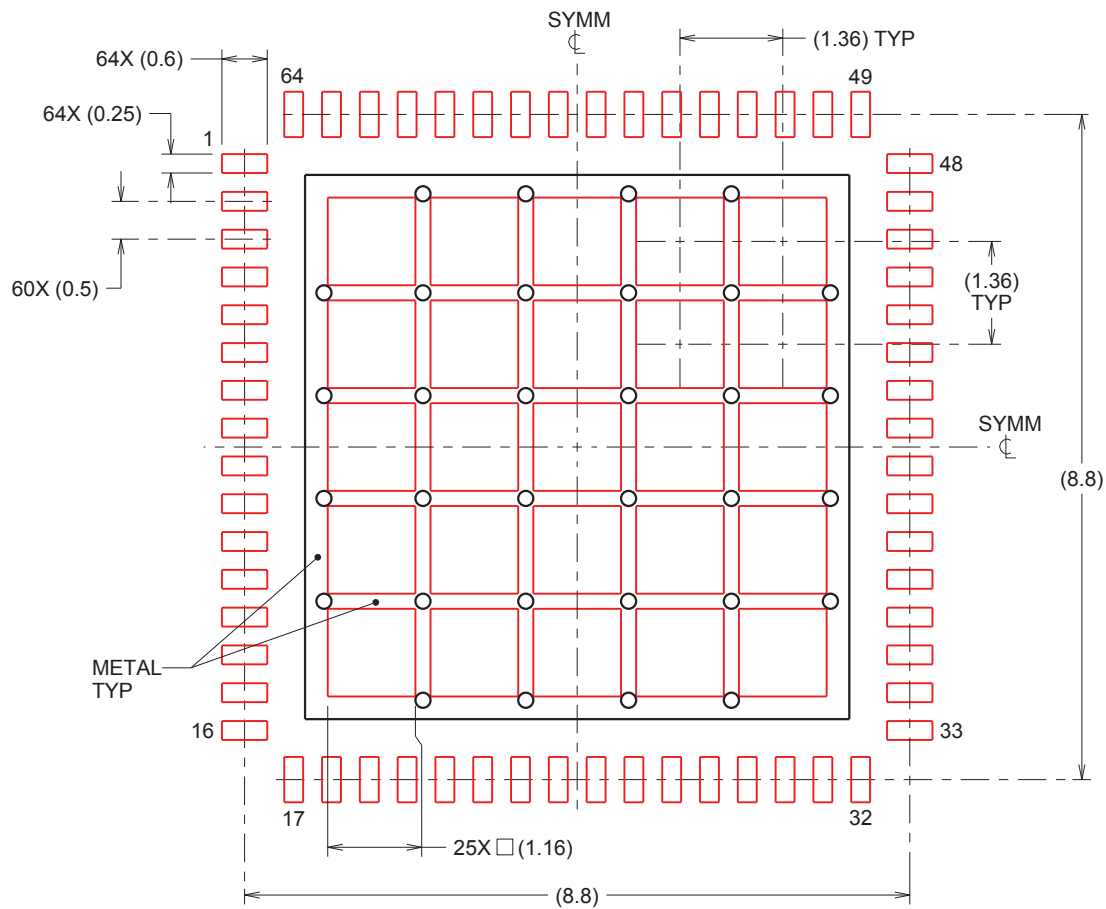

**Figure 44. 64-Pin WQFN Stencil Example of Via and Opening Placement (dimensions in mm)**

Figure 45 (PCB layout example) is derived from a layout design of the DS90UB940-Q1. This graphic and additional layout description are used to demonstrate both proper routing and proper solder techniques when designing in the Deserializer.

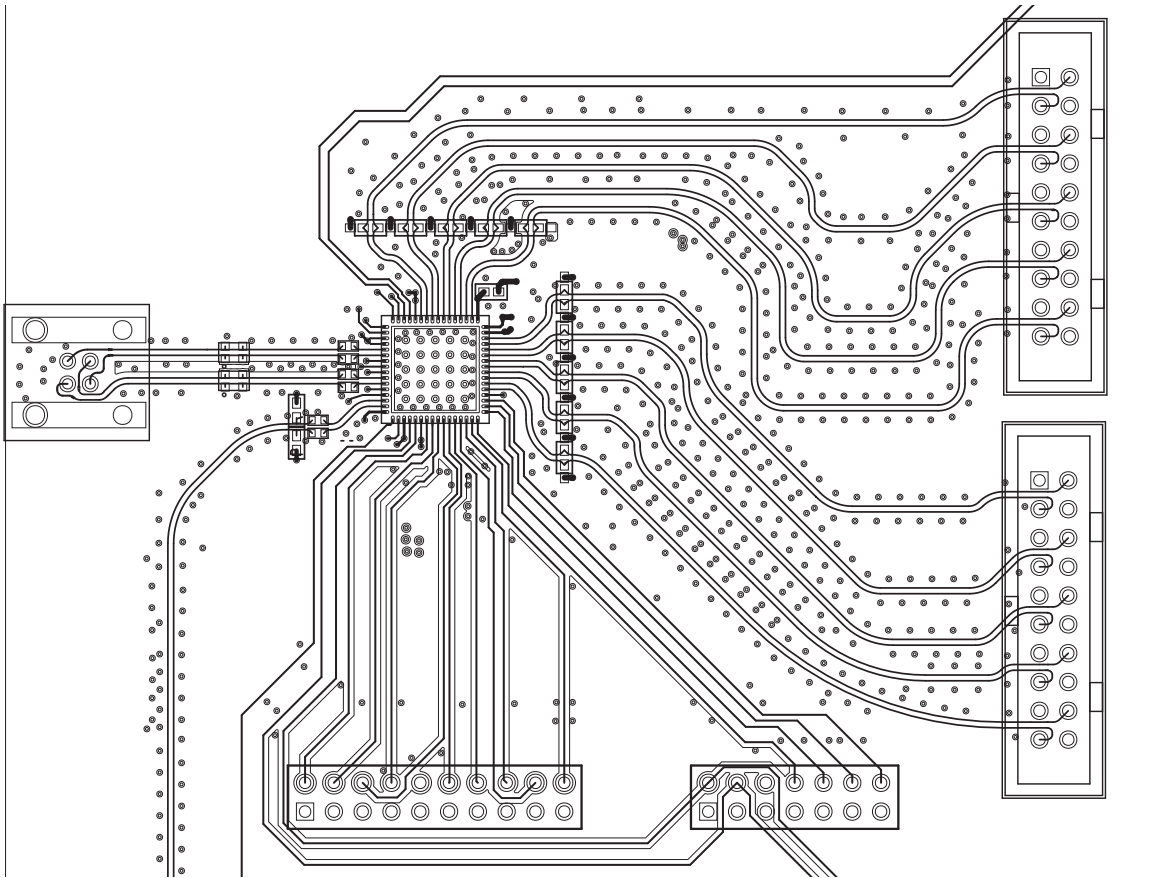

**Figure 45. DS90UB940-Q1 Deserializer Example Layout**

## 12 器件和文档支持

### 12.1 文档支持

#### 12.1.1 相关文档

相关文档如下:

- 《焊接规范应用报告》， [SNOA549](#)
- 《IC 封装热指标应用报告》， [SPRA953](#)
- 《通道链路 PCB 和互连设计指南》， [SNLA008](#)
- 《传输线路 RAPIDESIGNER 操作和应用指南》， [SNLA035](#)
- 《无引线框架封装 (LLP) 应用报告》， [SNOA401](#)
- 《LVDS 所有者手册》， [SNLA187](#)
- 《通过具有双向控制通道的 FPD-Link III 进行 I2C 通信》， [SNLA131](#)
- 《使用 DS90Ux92x FPD-Link III 器件的 I2S 音频接口》， [SNLA221](#)
- 《探索 720p FPD-Link III 器件的内部测试图案生成特性》， [SNLA132](#)

### 12.2 社区资源

The following links connect to TI community resources. Linked contents are provided "AS IS" by the respective contributors. They do not constitute TI specifications and do not necessarily reflect TI's views; see TI's [Terms of Use](#).

**TI E2E™ Online Community** *TI's Engineer-to-Engineer (E2E) Community*. Created to foster collaboration among engineers. At [e2e.ti.com](http://e2e.ti.com), you can ask questions, share knowledge, explore ideas and help solve problems with fellow engineers.

**Design Support** *TI's Design Support* Quickly find helpful E2E forums along with design support tools and contact information for technical support.

### 12.3 商标

E2E is a trademark of Texas Instruments.  
All other trademarks are the property of their respective owners.

### 12.4 静电放电警告



这些装置包含有限的内置 ESD 保护。存储或装卸时，应将导线一起截短或将装置放置于导电泡棉中，以防止 MOS 门极遭受静电损伤。

### 12.5 Glossary

[SLYZ022](#) — *TI Glossary*.

This glossary lists and explains terms, acronyms, and definitions.

## 13 机械、封装和可订购信息

以下页中包括机械、封装和可订购信息。这些信息是针对指定器件可提供的最新数据。这些数据会在无通知且不对本文档进行修订的情况下发生改变。欲获得该数据表的浏览器版本，请查阅左侧的导航栏。

**PACKAGING INFORMATION**

Orderable Device	Status (1)	Package Type	Package Drawing	Pins	Package Qty	Eco Plan (2)	Lead finish/ Ball material (6)	MSL Peak Temp (3)	Op Temp (°C)	Device Marking (4/5)	Samples
DS90UB940TNKDRQ1	ACTIVE	WQFN	NKD	64	2000	RoHS & Green	SN	Level-3-260C-168 HR	-40 to 105	90UB940Q1	<a href="#">Samples</a>
DS90UB940TNKDTQ1	ACTIVE	WQFN	NKD	64	250	RoHS & Green	SN	Level-3-260C-168 HR	-40 to 105	90UB940Q1	<a href="#">Samples</a>

(1) The marketing status values are defined as follows:

**ACTIVE:** Product device recommended for new designs.

**LIFEBUY:** TI has announced that the device will be discontinued, and a lifetime-buy period is in effect.

**NRND:** Not recommended for new designs. Device is in production to support existing customers, but TI does not recommend using this part in a new design.

**PREVIEW:** Device has been announced but is not in production. Samples may or may not be available.

**OBSOLETE:** TI has discontinued the production of the device.

(2) **RoHS:** TI defines "RoHS" to mean semiconductor products that are compliant with the current EU RoHS requirements for all 10 RoHS substances, including the requirement that RoHS substance do not exceed 0.1% by weight in homogeneous materials. Where designed to be soldered at high temperatures, "RoHS" products are suitable for use in specified lead-free processes. TI may reference these types of products as "Pb-Free".

**RoHS Exempt:** TI defines "RoHS Exempt" to mean products that contain lead but are compliant with EU RoHS pursuant to a specific EU RoHS exemption.

**Green:** TI defines "Green" to mean the content of Chlorine (Cl) and Bromine (Br) based flame retardants meet JS709B low halogen requirements of <=1000ppm threshold. Antimony trioxide based flame retardants must also meet the <=1000ppm threshold requirement.

(3) MSL, Peak Temp. - The Moisture Sensitivity Level rating according to the JEDEC industry standard classifications, and peak solder temperature.

(4) There may be additional marking, which relates to the logo, the lot trace code information, or the environmental category on the device.

(5) Multiple Device Markings will be inside parentheses. Only one Device Marking contained in parentheses and separated by a "~" will appear on a device. If a line is indented then it is a continuation of the previous line and the two combined represent the entire Device Marking for that device.

(6) Lead finish/Ball material - Orderable Devices may have multiple material finish options. Finish options are separated by a vertical ruled line. Lead finish/Ball material values may wrap to two lines if the finish value exceeds the maximum column width.

**Important Information and Disclaimer:**The information provided on this page represents TI's knowledge and belief as of the date that it is provided. TI bases its knowledge and belief on information provided by third parties, and makes no representation or warranty as to the accuracy of such information. Efforts are underway to better integrate information from third parties. TI has taken and continues to take reasonable steps to provide representative and accurate information but may not have conducted destructive testing or chemical analysis on incoming materials and chemicals. TI and TI suppliers consider certain information to be proprietary, and thus CAS numbers and other limited information may not be available for release.

In no event shall TI's liability arising out of such information exceed the total purchase price of the TI part(s) at issue in this document sold by TI to Customer on an annual basis.



**TAPE AND REEL INFORMATION**

**QUADRANT ASSIGNMENTS FOR PIN 1 ORIENTATION IN TAPE**

\*All dimensions are nominal

Device	Package Type	Package Drawing	Pins	SPQ	Reel Diameter (mm)	Reel Width W1 (mm)	A0 (mm)	B0 (mm)	K0 (mm)	P1 (mm)	W (mm)	Pin1 Quadrant
DS90UB940TNKDRQ1	WQFN	NKD	64	2000	330.0	16.4	9.3	9.3	1.3	12.0	16.0	Q1
DS90UB940TNKDTQ1	WQFN	NKD	64	250	178.0	16.4	9.3	9.3	1.3	12.0	16.0	Q1

**TAPE AND REEL BOX DIMENSIONS**

\*All dimensions are nominal

Device	Package Type	Package Drawing	Pins	SPQ	Length (mm)	Width (mm)	Height (mm)
DS90UB940TNKDRQ1	WQFN	NKD	64	2000	356.0	356.0	36.0
DS90UB940TNKDTQ1	WQFN	NKD	64	250	208.0	191.0	35.0



## GENERIC PACKAGE VIEW

**NKD 64**

**WQFN - 0.8 mm max height**

9 x 9, 0.5 mm pitch

PLASTIC QUAD FLATPACK - NO LEAD

This image is a representation of the package family, actual package may vary.  
Refer to the product data sheet for package details.

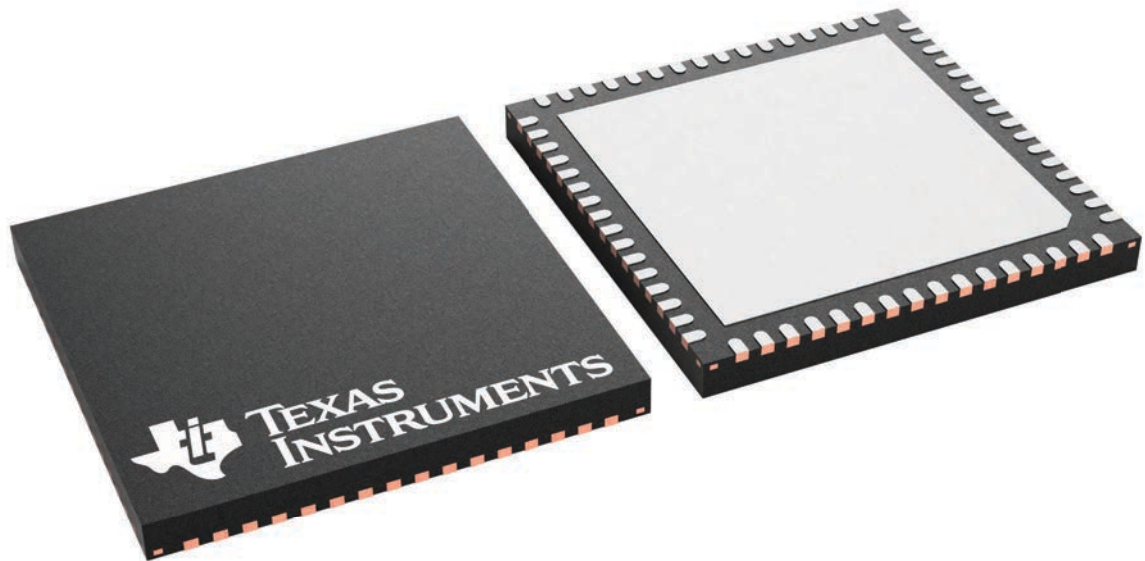

4229637/A

# PACKAGE OUTLINE

NKD0064A

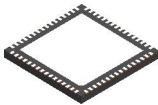

WQFN - 0.8 mm max height

WQFN

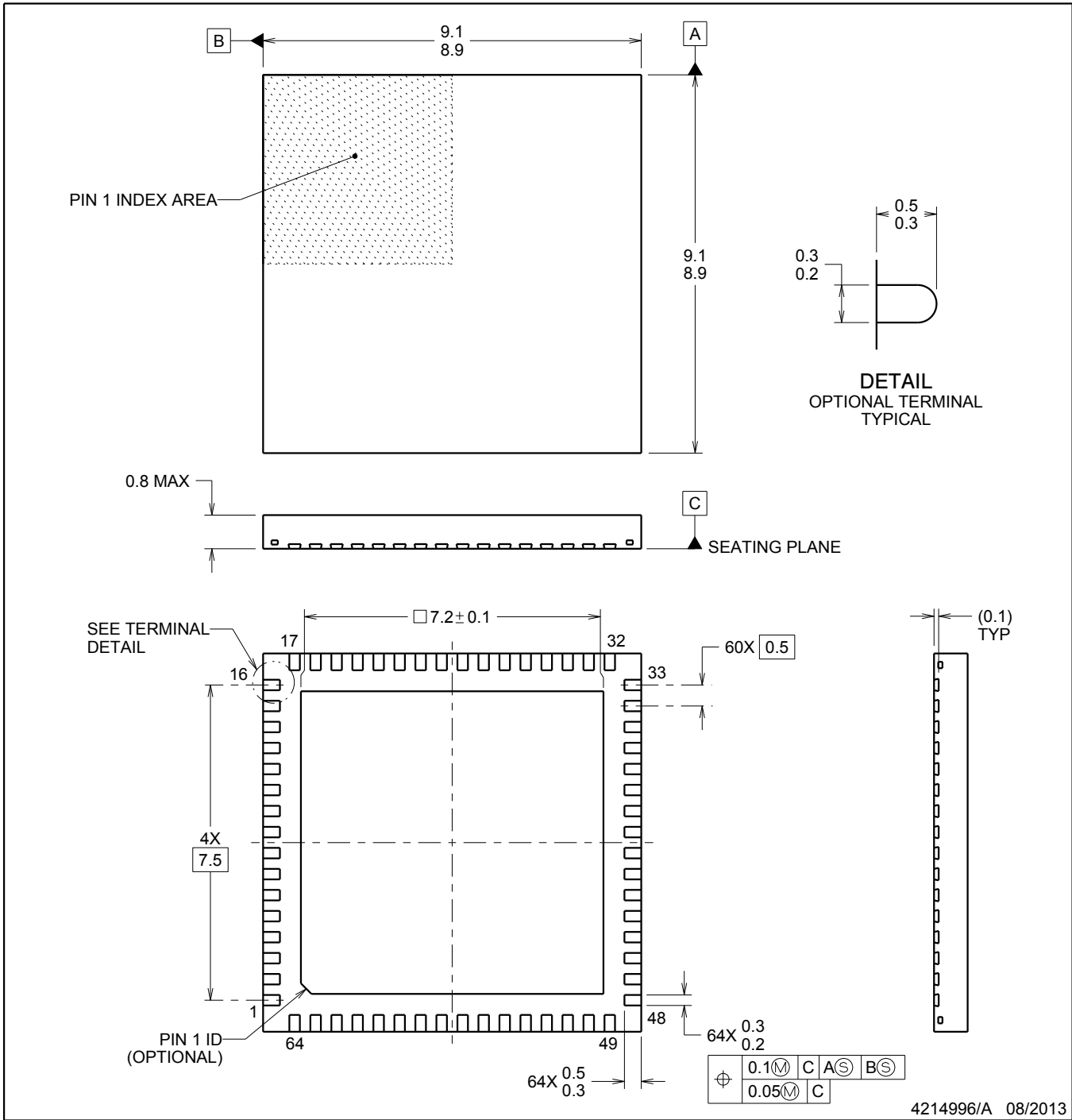

**NOTES:**

1. All linear dimensions are in millimeters. Dimensions in parenthesis are for reference only. Dimensioning and tolerancing per ASME Y14.5M.
2. This drawing is subject to change without notice.
3. The package thermal pad must be soldered to the printed circuit board for thermal and mechanical performance.

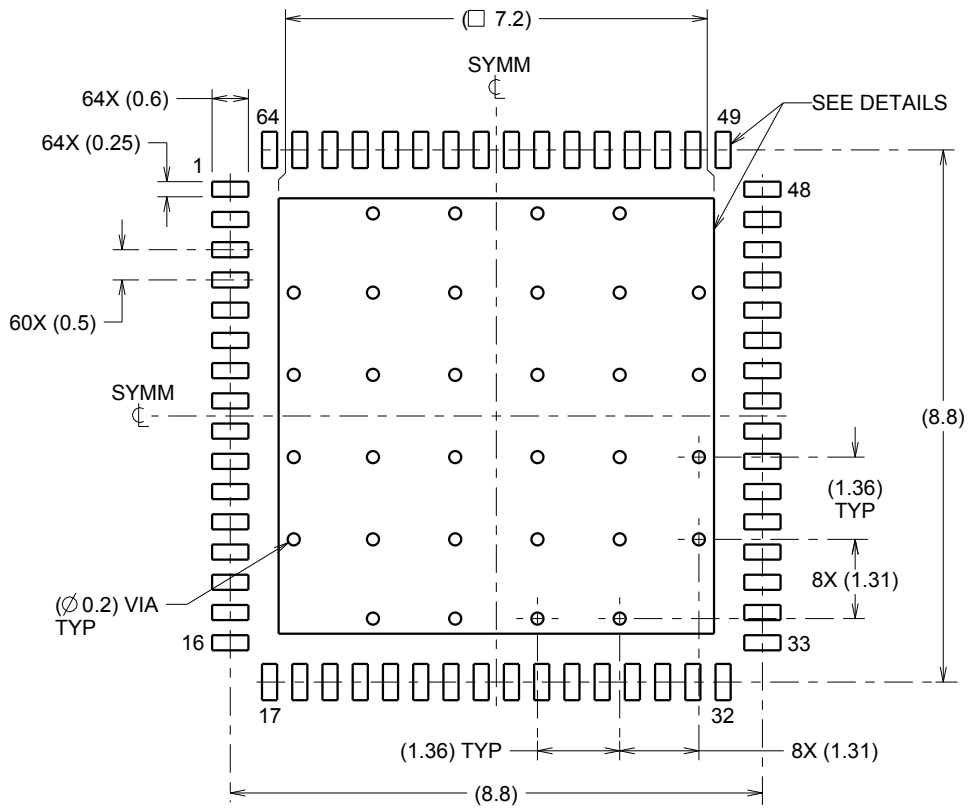

LAND PATTERN EXAMPLE  
SCALE:8X

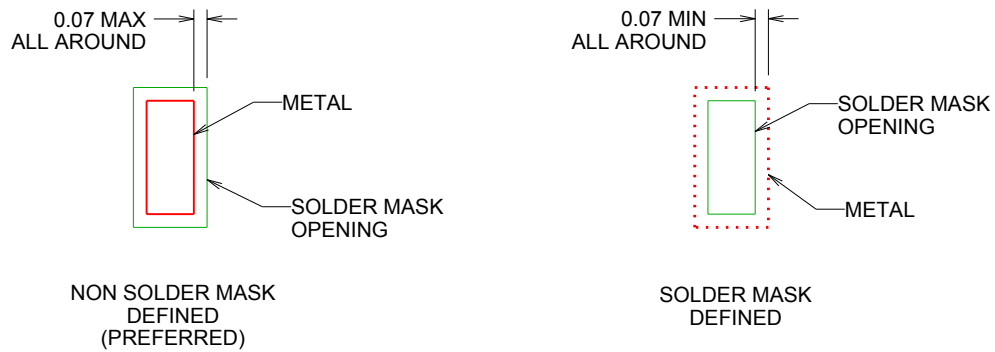

SOLDER MASK DETAILS

4214996/A 08/2013

NOTES: (continued)

- This package is designed to be soldered to a thermal pad on the board. For more information, refer to QFN/SON PCB application note in literature No. SLUA271 ([www.ti.com/lit/sluea271](http://www.ti.com/lit/sluea271)).

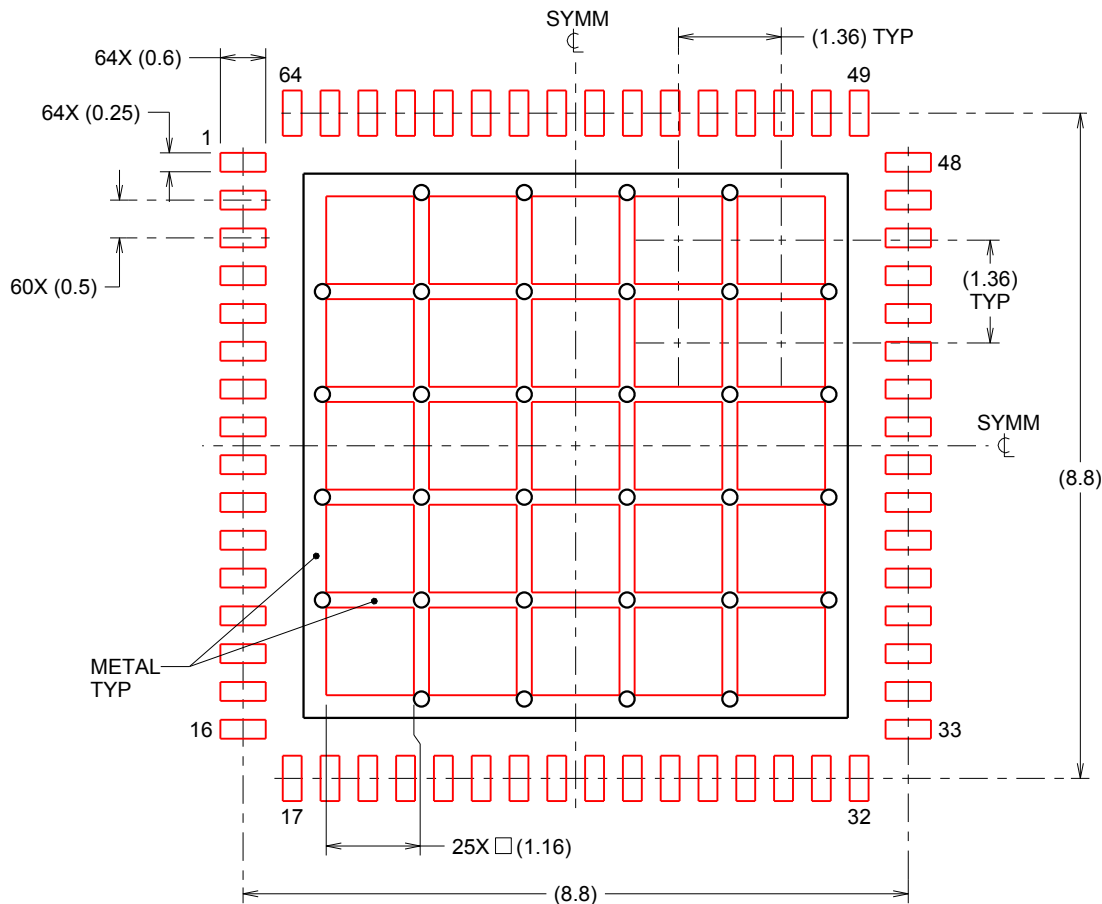

**SOLDERPASTE EXAMPLE**  
 BASED ON 0.125mm THICK STENCIL  
 EXPOSED PAD  
 65% PRINTED SOLDER COVERAGE BY AREA  
 SCALE:10X

4214996/A 08/2013

NOTES: (continued)

5. Laser cutting apertures with trapezoidal walls and rounded corners may offer better paste release. IPC-7525 may have alternate design recommendations.

## 重要声明和免责声明

TI“按原样”提供技术和可靠性数据（包括数据表）、设计资源（包括参考设计）、应用或其他设计建议、网络工具、安全信息和其他资源，不保证没有瑕疵且不做任何明示或暗示的担保，包括但不限于对适销性、某特定用途方面的适用性或不侵犯任何第三方知识产权的暗示担保。

这些资源可供使用 TI 产品进行设计的熟练开发人员使用。您将自行承担以下全部责任：(1) 针对您的应用选择合适的 TI 产品，(2) 设计、验证并测试您的应用，(3) 确保您的应用满足相应标准以及任何其他功能安全、信息安全、监管或其他要求。

这些资源如有变更，恕不另行通知。TI 授权您仅可将这些资源用于研发本资源所述的 TI 产品的应用。严禁对这些资源进行其他复制或展示。您无权使用任何其他 TI 知识产权或任何第三方知识产权。您应全额赔偿因在这些资源的使用中对 TI 及其代表造成的任何索赔、损害、成本、损失和债务，TI 对此概不负责。

TI 提供的产品受 [TI 的销售条款](#) 或 [ti.com](#) 上其他适用条款/TI 产品随附的其他适用条款的约束。TI 提供这些资源并不会扩展或以其他方式更改 TI 针对 TI 产品发布的适用的担保或担保免责声明。

TI 反对并拒绝您可能提出的任何其他或不同的条款。

邮寄地址：Texas Instruments, Post Office Box 655303, Dallas, Texas 75265

Copyright © 2024，德州仪器 (TI) 公司