

## LM60 2.7V、SOT-23 或 TO-92 温度传感器

### 1 特性

- 校准后的线性比例因子为 6.25mV/°C
- 额定温度范围为 -40°C 至 +125°C
- 适用于远程 应用
- 采用 SOT-23 和 TO-92 封装
- 主要技术规格
  - 25°C 时的精度:  $\pm 2^\circ\text{C}$  和  $\pm 3^\circ\text{C}$  (最大值)
  - -40°C 至 +125°C 时的精度:  $\pm 4^\circ\text{C}$  (最大值)
  - -25°C 至 +125°C 时的精度:  $\pm 3^\circ\text{C}$  (最大值)
  - 温度斜率: 6.25mV/°C
  - 电源电压范围: 2.7V 至 10V
  - 25°C 时的电流消耗: 110 $\mu\text{A}$  (最大值)
  - 非线性:  $\pm 0.8^\circ\text{C}$  (最大值)
  - 输出阻抗: 800 $\Omega$  (最大值)

### 2 应用

- 手机和计算机
- 电源模块
- 电池管理
- 传真机和打印机
- HVAC 和磁盘驱动器
- 电器

### 3 说明

LM60 器件是一种精密集成电路温度传感器，可由 2.7V 单电源供电，并可检测 -40°C 至 +125°C 的温度范围。此器件的输出电压与摄氏温度成正比 (6.25mV/°C)，并具有 424mV 的

直流失调电压。凭借此失调电压，在无需负电源的情况下即可读取负温度值。对于 -40°C 至 +125°C 的温度范围，此器件的标称输出电压范围介于 174mV 至 1205mV 之间。此器件经校准后可在室温下提供  $\pm 2^\circ\text{C}$  的精度，而在 -25°C 至 +125°C 的完整温度范围内提供  $\pm 3^\circ\text{C}$  的精度。

此器件的线性输出、+424mV 失调电压和出厂校准简化了要求读取负温度值的单电源环境中所需要的外部电路。因为此器件的静态电流小于 110 $\mu\text{A}$ ，所以在 SOT-23 封装中的静止空气中，自热限制在非常低的 0.1°C。此器件本身便具备关断功能，这是因为其自身功耗低，因此可直接通过许多逻辑门的输出供电。

器件信息(1)

器件型号	封装	封装尺寸 (标称值)
LM60	TO-92 (3)	4.30mm × 4.30mm
	SOT-23 (3)	2.92mm × 1.30mm

(1) 如需了解所有可用封装，请参阅数据表末尾的可订购产品附录。

简化电路原理图

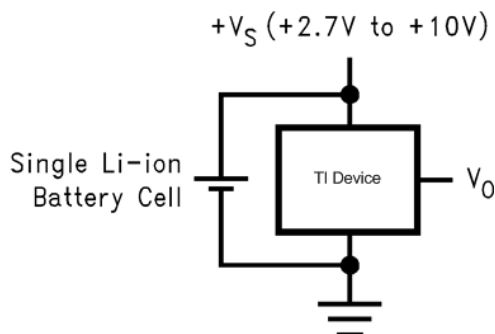

Copyright © 2017, Texas Instruments Incorporated

全范围摄氏温度传感器  
(-40°C 至 +125°C)

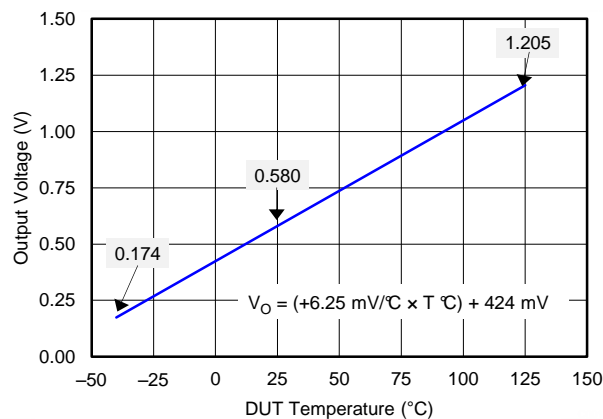

## 目录

<b>1</b>	特性 .....	<b>1</b>	8.4	Device Functional Modes.....	<b>9</b>
<b>2</b>	应用 .....	<b>1</b>	<b>9</b>	<b>Application and Implementation</b> .....	<b>10</b>
<b>3</b>	说明 .....	<b>1</b>	9.1	Application Information.....	<b>10</b>
<b>4</b>	修订历史记录 .....	<b>2</b>	9.2	Typical Applications .....	<b>11</b>
<b>5</b>	<b>Device Comparison Table</b> .....	<b>3</b>	9.3	System Examples .....	<b>13</b>
<b>6</b>	<b>Pin Configuration and Functions</b> .....	<b>4</b>	<b>10</b>	<b>Power Supply Recommendations</b> .....	<b>13</b>
<b>7</b>	<b>Specifications</b> .....	<b>4</b>	<b>11</b>	<b>Layout</b> .....	<b>14</b>
7.1	Absolute Maximum Ratings .....	<b>4</b>	11.1	Layout Guidelines .....	<b>14</b>
7.2	ESD Ratings .....	<b>4</b>	11.2	Layout Example .....	<b>14</b>
7.3	Recommended Operating Conditions .....	<b>5</b>	11.3	Thermal Considerations .....	<b>14</b>
7.4	Thermal Information .....	<b>5</b>	<b>12</b>	器件和文档支持 .....	<b>16</b>
7.5	Electrical Characteristics .....	<b>5</b>	12.1	接收文档更新通知 .....	<b>16</b>
7.6	Typical Characteristics .....	<b>7</b>	12.2	社区资源 .....	<b>16</b>
<b>8</b>	<b>Detailed Description</b> .....	<b>9</b>	12.3	商标 .....	<b>16</b>
8.1	Overview .....	<b>9</b>	12.4	静电放电警告 .....	<b>16</b>
8.2	Functional Block Diagram .....	<b>9</b>	12.5	Glossary .....	<b>16</b>
8.3	Feature Description .....	<b>9</b>	<b>13</b>	机械、封装和可订购信息 .....	<b>16</b>

## 4 修订历史记录

<b>Changes from Revision E (September 2015) to Revision F</b>		<b>Page</b>
•	将汽车器件移到了单独的数据表中 (SNIS197) .....	<b>1</b>
•	Added tablenote for the LM60B .....	<b>3</b>
•	Added tablenote for the LM60B .....	<b>5</b>

<b>Changes from Revision D (November 2012) to Revision E</b>		<b>Page</b>
•	已添加 引脚配置和功能 部分、ESD 额定值表、特性说明 部分，器件功能模式，应用和实施部分，电源相关建议部分，布局部分，器件和文档支持部分以及机械、封装和可订购信息部分 .....	<b>1</b>

## 5 Device Comparison Table

ORDER NUMBER	ACCURACY OVER SPECIFIED TEMPERATURE RANGE	SPECIFIED TEMPERATURE RANGE
LM60BIM3	±3	–25°C ≤ T <sub>A</sub> ≤ +125°C <sup>(1)</sup>
LM60BIM3X		
LM60CIM3	±4	–40°C ≤ T <sub>A</sub> ≤ +125°C
LM60CIM3X		
LM60QIM3	±4	–40°C ≤ T <sub>A</sub> ≤ +125°C
LM60QIM3X		
LM60BIZ	±3	–25°C ≤ T <sub>A</sub> ≤ +125°C
LM60CIZ	±4	–40°C ≤ T <sub>A</sub> ≤ +125°C

(1) LM60B will operate down to –40°C without damage but the accuracy is only ensured from –25°C to 125°C.

## 6 Pin Configuration and Functions



### Pin Functions

NAME	PIN		TYPE	DESCRIPTION
	SOT-23	TO92		
GND	3	3	GND	Device ground, connected to power supply negative terminal
V <sub>OUT</sub>	2	2	O	Temperature sensor analog output
+V <sub>S</sub>	1	1	POWER	Positive power supply pin

## 7 Specifications

### 7.1 Absolute Maximum Ratings

over operating free-air temperature range (unless otherwise noted)<sup>(1)</sup>

	MIN	MAX	UNIT
Supply voltage	-0.2	12	V
Output voltage	-0.6	V <sub>S</sub> + 0.6	V
Output current		10	mA
Input current at any pin <sup>(2)</sup>		5	mA
Maximum junction temperature (T <sub>JMAX</sub> )		125	°C
Storage temperature (T <sub>stg</sub> )	-65	150	°C

- (1) Stresses beyond those listed under *Absolute Maximum Ratings* may cause permanent damage to the device. These are stress ratings only, which do not imply functional operation of the device at these or any other conditions beyond those indicated under *Recommended Operating Conditions*. Exposure to absolute-maximum-rated conditions for extended periods may affect device reliability.
- (2) When the input voltage (V<sub>I</sub>) at any pin exceeds power supplies (V<sub>I</sub> < GND or V<sub>I</sub> > +V<sub>S</sub>), the current at that pin should be limited to 5 mA.

### 7.2 ESD Ratings

		VALUE	UNIT
<b>LM60 in DBZ Package</b>			
V <sub>(ESD)</sub>	Electrostatic discharge <sup>(1)</sup>	Human-body model (HBM)	V
		Machine model (MM)	
<b>LM60 in LP Package</b>			
V <sub>(ESD)</sub>	Electrostatic discharge <sup>(1)</sup>	Human-body model (HBM)	V
		Machine model (MM)	

- (1) The human body model is a 100-pF capacitor discharged through a 1.5-kΩ resistor into each pin. The machine model is a 200-pF capacitor discharged directly into each pin.

### 7.3 Recommended Operating Conditions

over operating free-air temperature range (unless otherwise noted)<sup>(1)</sup>

	MIN	MAX	UNIT
LM60B ( $T_{MIN} \leq T_A \leq T_{MAX}$ )	-25 <sup>(2)</sup>	125	°C
LM60C ( $T_{MIN} \leq T_A \leq T_{MAX}$ )	-40	125	°C
Supply voltage (+V <sub>S</sub> )	2.7	10	V

- (1) Soldering process must comply with National Semiconductor's Reflow Temperature Profile specifications. Refer to [www.national.com/packaging](http://www.national.com/packaging). Reflow temperature profiles are different for lead-free and non-lead-free packages.
- (2) LM60B will operate down to -40°C without damage but the accuracy is only ensured from -25°C to 125°C.

### 7.4 Thermal Information

THERMAL METRIC <sup>(1)</sup>		LM60		UNIT
		DBZ (SOT-23)	LP (TO-92)	
		3 PINS	3 PINS	
R <sub>θJA</sub> <sup>(2)</sup>	Junction-to-ambient thermal resistance	266	162	°C/W
R <sub>θJC(top)</sub>	Junction-to-case (top) thermal resistance	135	85	°C/W
R <sub>θJB</sub>	Junction-to-board thermal resistance	59	—	°C/W
ψ <sub>JT</sub>	Junction-to-top characterization parameter	18	29	°C/W
ψ <sub>JB</sub>	Junction-to-board characterization parameter	58	142	°C/W

- (1) For more information about traditional and new thermal metrics, see the [Semiconductor or IC Package Thermal Metrics](#) application report.
- (2) The junction to ambient thermal resistance (R<sub>θJA</sub>) is specified without a heat sink in still air.

### 7.5 Electrical Characteristics

Unless otherwise noted, these specifications apply for +V<sub>S</sub> = 3 V<sub>DC</sub> and I<sub>LOAD</sub> = 1 μA. All limits T<sub>A</sub> = T<sub>J</sub> = 25°C unless otherwise noted.

PARAMETER	TEST CONDITIONS		MIN <sup>(1)</sup>	TYP <sup>(2)</sup>	MAX <sup>(1)</sup>	UNIT
Accuracy <sup>(3)</sup>	LM60B		-2		2	°C
		T <sub>A</sub> = T <sub>J</sub> = T <sub>MIN</sub> to T <sub>MAX</sub>	-3		3	
	LM60C		-3		3	°C
		T <sub>A</sub> = T <sub>J</sub> = T <sub>MIN</sub> to T <sub>MAX</sub>	-4		4	
Output voltage at 0°C				424		mV
Nonlinearity <sup>(4)</sup>	LM60B	T <sub>A</sub> = T <sub>J</sub> = T <sub>MIN</sub> to T <sub>MAX</sub>	-0.6		±0.6	°C
	LM60C	T <sub>A</sub> = T <sub>J</sub> = T <sub>MIN</sub> to T <sub>MAX</sub>	-0.8		±0.8	
Sensor gain (average slope)				6.25		mV/°C
	LM60B	T <sub>A</sub> = T <sub>J</sub> = T <sub>MIN</sub> to T <sub>MAX</sub>	6.06		6.44	
	LM60C	T <sub>A</sub> = T <sub>J</sub> = T <sub>MIN</sub> to T <sub>MAX</sub>	6		6.5	
Output impedance	T <sub>A</sub> = T <sub>J</sub> = T <sub>MIN</sub> to T <sub>MAX</sub>				800	Ω

- (1) Limits are specified to TI's AOQL (Average Outgoing Quality Level).
- (2) Typicals are at T<sub>J</sub> = T<sub>A</sub> = 25°C and represent most likely parametric norm.
- (3) Accuracy is defined as the error between the output voltage and 6.25 mV/°C times the case temperature of the device plus 424 mV, at specified conditions of voltage, current, and temperature (expressed in °C).
- (4) Nonlinearity is defined as the deviation of the output-voltage-versus-temperature curve from the best-fit straight line, over the rated temperature range of the device.

**Electrical Characteristics (continued)**

Unless otherwise noted, these specifications apply for  $+V_S = 3 V_{DC}$  and  $I_{LOAD} = 1 \mu A$ . All limits  $T_A = T_J = 25^\circ C$  unless otherwise noted.

PARAMETER	TEST CONDITIONS		MIN <sup>(1)</sup>	TYP <sup>(2)</sup>	MAX <sup>(1)</sup>	UNIT
Line regulation <sup>(5)</sup>	$3 V \leq +V_S \leq 10 V$	$T_A = T_J = T_{MIN}$ to $T_{MAX}$	-0.3		0.3	mV/V
	$2.7 V \leq +V_S \leq 3.3 V$	$T_A = T_J = T_{MIN}$ to $T_{MAX}$	-2.3		2.3	mV
Quiescent current	$2.7 V \leq +V_S \leq 10 V$			82	110	$\mu A$
		$T_A = T_J = T_{MIN}$ to $T_{MAX}$			125	$\mu A$
Change of quiescent current	$2.7 V \leq +V_S \leq 10 V$			$\pm 5$		$\mu A$
Temperature coefficient of quiescent current				0.2		$\mu A/^\circ C$
Long-term stability <sup>(6)</sup>	$T_J = T_{MAX} = 125^\circ C$ for 1000 hours			$\pm 0.2$		$^\circ C$

- (5) Regulation is measured at constant junction temperature, using pulse testing with a low duty cycle. Changes in output due to heating effects can be computed by multiplying the internal dissipation by the thermal resistance.
- (6) For best long-term stability, any precision circuit will give best results if the unit is aged at a warm temperature, temperature cycled for at least 46 hours before long-term life test begins for both temperatures. This is especially true when a small (surface-mount) part is wave-soldered; allow time for stress relaxation to occur. The majority of the drift will occur in the first 1000 hours at elevated temperatures. The drift after 1000 hours will not continue at the first 1000 hour rate.

## 7.6 Typical Characteristics

To generate these curves, the device was mounted to a printed-circuit board as shown in [Figure 20](#).

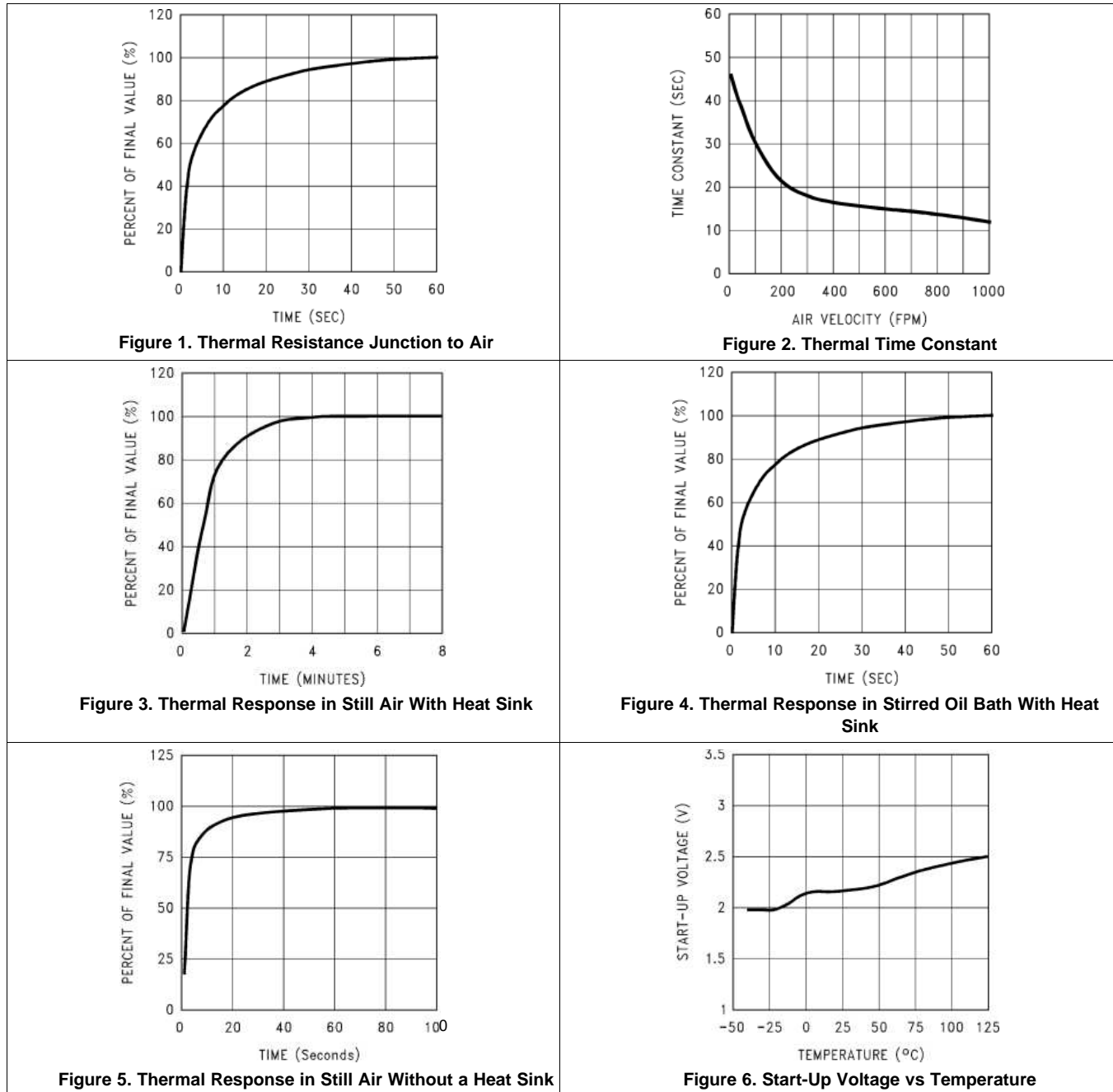

**Typical Characteristics (continued)**

To generate these curves, the device was mounted to a printed-circuit board as shown in Figure 20.

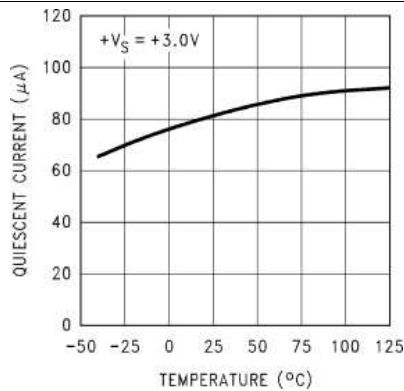

**Figure 7. Quiescent Current vs Temperature**

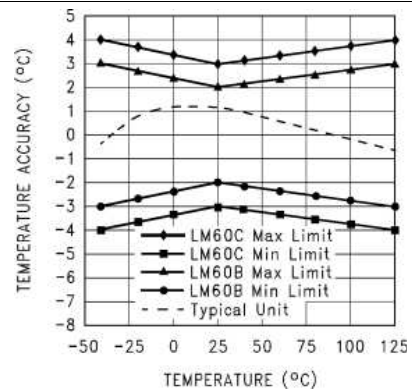

**Figure 8. Accuracy vs Temperature**

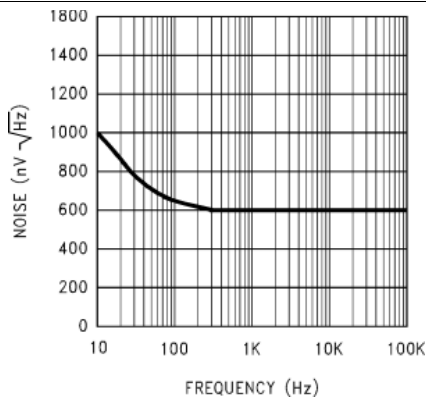

**Figure 9. Noise Voltage**

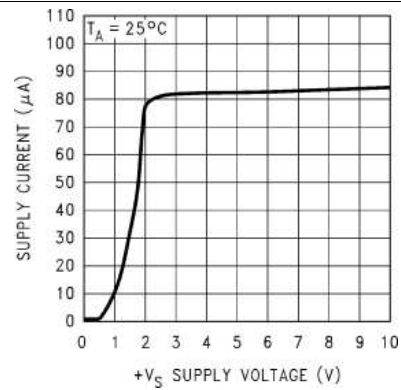

**Figure 10. Supply Voltage vs Supply Current**

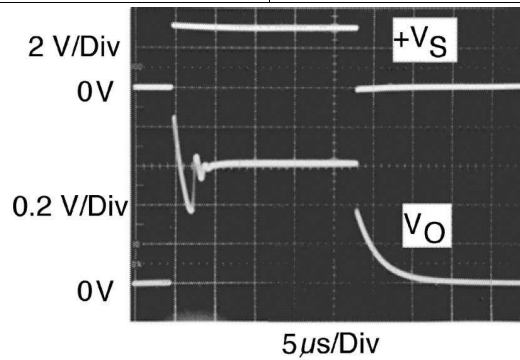

**Figure 11. Start-Up Response**

SVA-1268122



## 8 Detailed Description

### 8.1 Overview

The LM60 devices are precision analog bipolar temperature sensors that can sense a  $-40^{\circ}\text{C}$  to  $+125^{\circ}\text{C}$  temperature range while operating from a single 2.7-V supply. The output voltage of the LM60 is linearly proportional to Celsius (Centigrade) temperature ( $6.25\text{ mV}/^{\circ}\text{C}$ ) and has a DC offset of 424 mV. The offset allows reading negative temperatures with a single positive supply. The nominal output voltage of the device ranges from 174 mV to 1205 mV for a  $-40^{\circ}\text{C}$  to  $+125^{\circ}\text{C}$  temperature range. The device is calibrated to provide accuracies of  $\pm 2.0^{\circ}\text{C}$  at room temperature and  $\pm 3^{\circ}\text{C}$  over the full  $-25^{\circ}\text{C}$  to  $+125^{\circ}\text{C}$  temperature range.

With a quiescent current of the device is less than  $110\ \mu\text{A}$ , self-heating is limited to a very low  $0.1^{\circ}\text{C}$  in still air in the SOT-23 package. Shutdown capability for the device is intrinsic because its inherent low power consumption allows it to be powered directly from the output of many logic gates.

The output of the LM60 is a Class A base emitter follower, thus the LM60 can source quite a bit of current while sinking less than  $1\ \mu\text{A}$ . In any event load current should be minimized in order to limit its contribution to the total temperature error. The temperature-sensing element is based on a delta  $V_{\text{BE}}$  topology of two transistors (Q1 and Q2 in [Functional Block Diagram](#)) that are sized with a 10:1 area ratio.

### 8.2 Functional Block Diagram

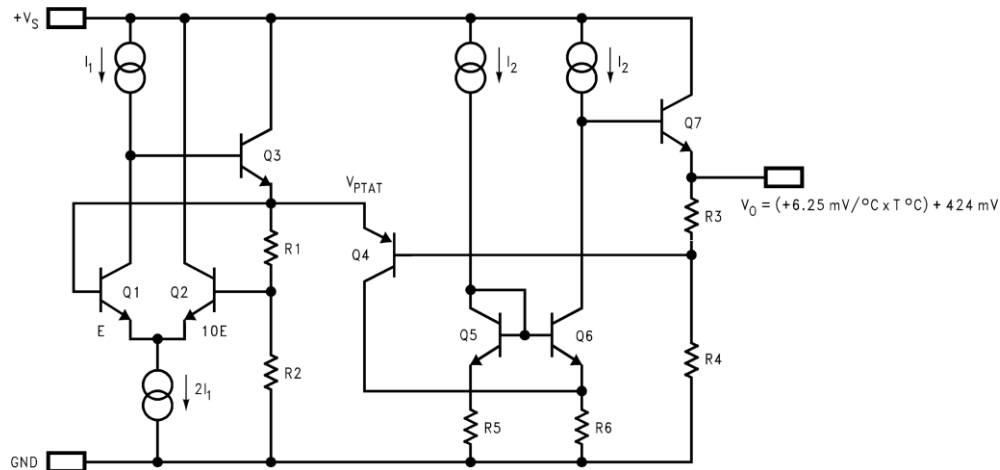

### 8.3 Feature Description

#### 8.3.1 LM60 Transfer Function

The LM60 follows a simple linear transfer function to achieve the accuracy as listed in [Electrical Characteristics](#) as given:

$$V_O = (6.25\text{ mV}/^{\circ}\text{C} \times T\ ^{\circ}\text{C}) + 424\text{ mV}$$

where

- T is the temperature
- $V_O$  is the LM60 output voltage

(1)

### 8.4 Device Functional Modes

The only functional mode for this device is an analog output directly proportional to temperature.

## 9 Application and Implementation

### NOTE

Information in the following applications sections is not part of the TI component specification, and TI does not warrant its accuracy or completeness. TI's customers are responsible for determining suitability of components for their purposes. Customers should validate and test their design implementation to confirm system functionality.

### 9.1 Application Information

The device has a low supply current and a wide supply range, therefore it can easily be driven by a battery.

#### 9.1.1 Capacitive Loads

The device handles capacitive loading well. Without any special precautions, the device can drive any capacitive load as shown in [Figure 12](#). Over the specified temperature range the device has a maximum output impedance of  $800\ \Omega$ . In an extremely noisy environment, adding some filtering to minimize noise pick-up may be required. TI recommends that  $0.1\ \mu\text{F}$  be added from  $+V_S$  to GND to bypass the power supply voltage, as shown in [Figure 13](#). In a noisy environment, adding a capacitor from the output to ground may be required. A  $1\text{-}\mu\text{F}$  output capacitor with the  $800\text{-}\Omega$  output impedance forms a 199-Hz, low-pass filter. Because the thermal time constant of the device is much slower than the 6.3-ms time constant formed by the RC, the overall response time of the device is not significantly affected. For much larger capacitors, this additional time lag increases the overall response time of the device.

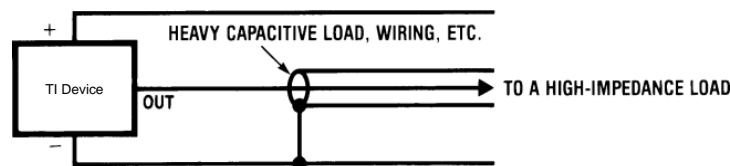

Copyright © 2017, Texas Instruments Incorporated

**Figure 12. No Decoupling Required for Capacitive Load**

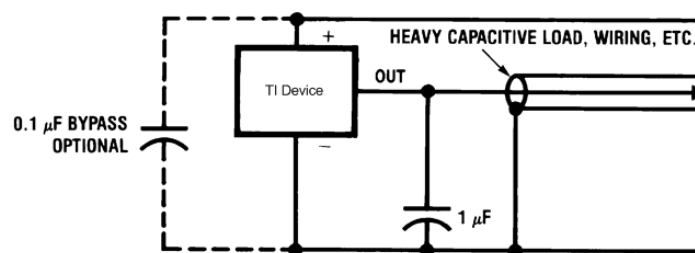

Copyright © 2017, Texas Instruments Incorporated

**Figure 13. Filter Added for Noisy Environment**

## 9.2 Typical Applications

### 9.2.1 Full-Range Centigrade Temperature Sensor

Because the LM60 is a simple temperature sensor that provides an analog output, design requirements related to the layout are also important. Refer to [Layout](#) for details.

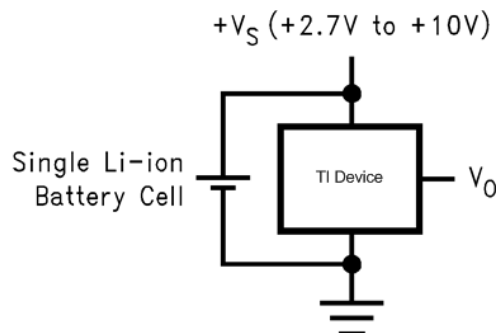

Copyright © 2017, Texas Instruments Incorporated

$$V_O = (6.25 \text{ mV/}^\circ\text{C} \times T^\circ\text{C}) + 424 \text{ mV}$$

**Figure 14. Full-Range Centigrade Temperature Sensor (–40°C to +125°C) Operating From a Single Li-Ion Battery Cell**

#### 9.2.1.1 Design Requirements

For this design example, use the design parameters listed in [Table 1](#).

**Table 1. Temperature and Typical V<sub>O</sub> Values of [Figure 14](#)**

TEMPERATURE (T)	TYPICAL V <sub>O</sub>
125°C	1205 mV
100°C	1049 mV
25°C	580 mV
0°C	424 mV
–25°C	268 mV
–40°C	174 mV

### 9.2.1.2 Detailed Design Procedure

Selection of the LM60 is based on the output voltage transfer function being able to meet the needs of the rest of the system.

### 9.2.1.3 Application Curve

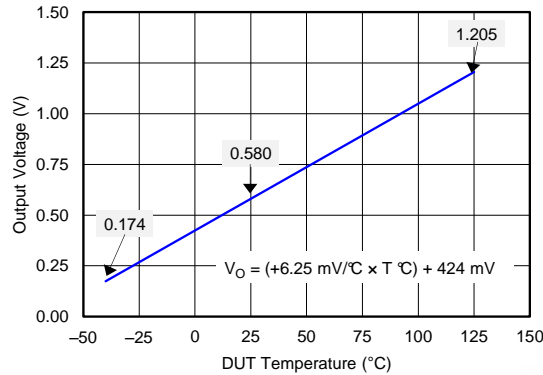
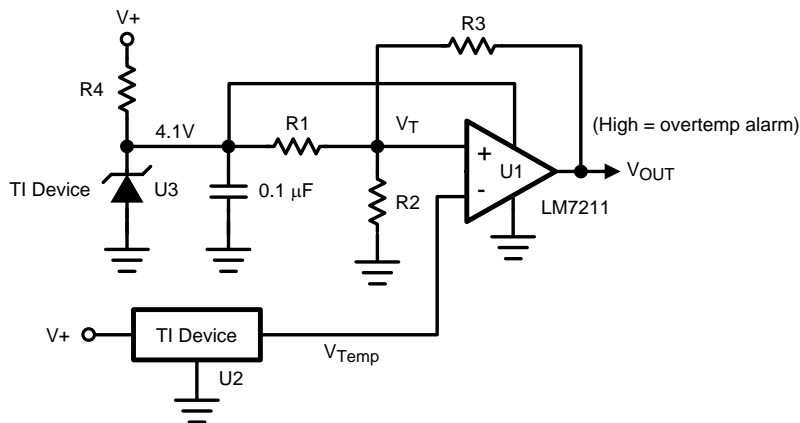

Figure 15. LM60 Output Transfer Function

## 9.2.2 Centigrade Thermostat Application



Copyright © 2017, Texas Instruments Incorporated

Figure 16. Centigrade Thermostat

### 9.2.2.1 Design Requirements

A simple thermostat can be created by using a reference (LM4040) and a comparator (LM7211) as shown in Figure 16.

### 9.2.2.2 Detailed Design Procedure

Use Equation 2 and Equation 3 to calculate the threshold values for T1 and T2.

$$V_{T1} = \frac{(4.1)R2}{R2 + R1 || R3} \tag{2}$$

$$V_{T2} = \frac{(4.1)R2 || R3}{R1 + R2 || R3} \tag{3}$$

### 9.2.2.3 Application Curve

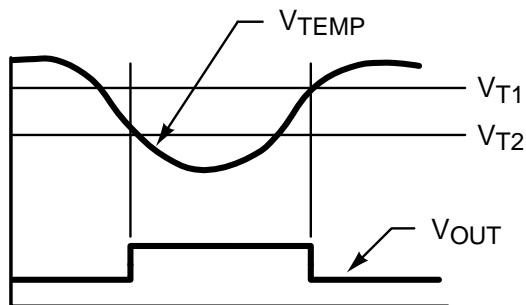
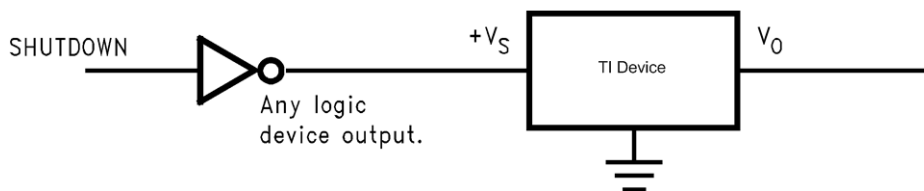

Figure 17. Thermostat Output Waveform

## 9.3 System Examples

### 9.3.1 Conserving Power Dissipation With Shutdown

The LM60 draws very little power, therefore it can simply be shutdown by driving the LM60 supply pin with the output of a logic gate as shown in Figure 18.



Copyright © 2017, Texas Instruments Incorporated

Figure 18. Conserving Power Dissipation With Shutdown

## 10 Power Supply Recommendations

In an extremely noisy environment, add some filtering to minimize noise pick-up. Adding 0.1  $\mu\text{F}$  from  $+V_S$  to GND is recommended to bypass the power supply voltage, as shown in Figure 13. In a noisy environment, add a capacitor from the output to ground.

## 11 Layout

### 11.1 Layout Guidelines

The LM60 can be applied easily in the same way as other integrated-circuit temperature sensors. It can be glued or cemented to a surface. The temperature that the LM60 is sensing will be within about +0.1°C of the surface temperature that the leads of the LM60 are attached to.

This presumes that the ambient air temperature is almost the same as the surface temperature. If the air temperature were much higher or lower than the surface temperature, the actual temperature of the device die would be at an intermediate temperature between the surface temperature and the air temperature.

To ensure good thermal conductivity the backside of the device die is directly attached to the GND pin. The lands and traces to the device will, of course, be part of the printed-circuit board, which is the object whose temperature is being measured. These printed-circuit board lands and traces do not cause the temperature of the device to deviate from the desired temperature.

Alternatively, the device can be mounted inside a sealed-end metal tube, and can then be dipped into a bath or screwed into a threaded hole in a tank. As with any IC, the device and accompanying wiring and circuits must be kept insulated and dry to avoid leakage and corrosion. Specifically when the device operates at cold temperatures where condensation can occur. Printed-circuit coatings and varnishes such as a conformal coating and epoxy paints or dips are often used to ensure that moisture cannot corrode the device or connections.

### 11.2 Layout Example

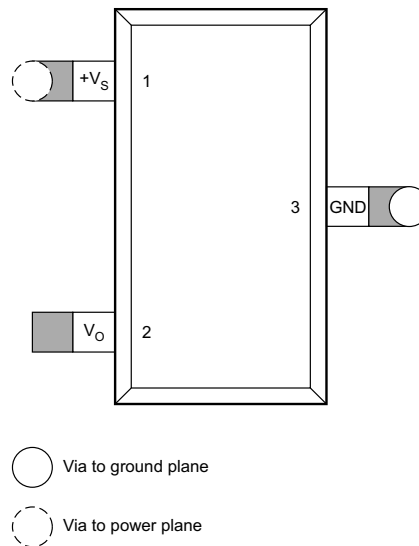

1/2-inch square printed circuit board with 2-oz. copper foil or similar.

**Figure 19. PCB Layout**

### 11.3 Thermal Considerations

The thermal resistance junction to ambient ( $R_{\theta JA}$ ) is the parameter used to calculate the rise of a device junction temperature due to the device power dissipation. Use [Equation 4](#) to calculate the rise in the die temperature of the device.

$$T_J = T_A + R_{\theta JA} [(+V_S I_Q) + (+V_S - V_O) I_L]$$

where

- $I_Q$  is the quiescent current
- $I_L$  is the load current on the output

(4)

### Thermal Considerations (continued)

Table 2 summarizes the rise in die temperature of the LM60 without any loading, and the thermal resistance for different conditions. The values in Table 2 were actually measured where as the values shown in Thermal Information were calculated using modeling methods as described in the *Semiconductor and IC Package Thermal Metrics* (SPRA953) application report.

**Table 2. Temperature Rise of LM60 Due to Self-Heating and Thermal Resistance ( $R_{\theta JA}$ )**

	SOT-23 <sup>(1)</sup> NO HEAT SINK		SOT-23 <sup>(2)</sup> SMALL HEAT FIN		TO-92 <sup>(1)</sup> NO HEAT FIN		TO-92 <sup>(3)</sup> SMALL HEAT FIN	
	$R_{\theta JA}$	$T_J - T_A$	$R_{\theta JA}$	$T_J - T_A$	$R_{\theta JA}$	$T_J - T_A$	$R_{\theta JA}$	$T_J - T_A$
	(°C/W)	(°C)	(°C/W)	(°C)	(°C/W)	(°C)	(°C/W)	(°C)
Still air	450	0.17	260	0.1	180	0.07	140	0.05
Moving air	—	—	180	0.07	90	0.034	70	0.026

- (1) Part soldered to 30 gauge wire.
- (2) Heat sink used is 1/2-in square printed-circuit board with 2-oz. foil with part attached as shown in Figure 20.
- (3) Part glued or leads soldered to 1-in square of 1/16-in printed-circuit board with 2-oz. foil or similar.

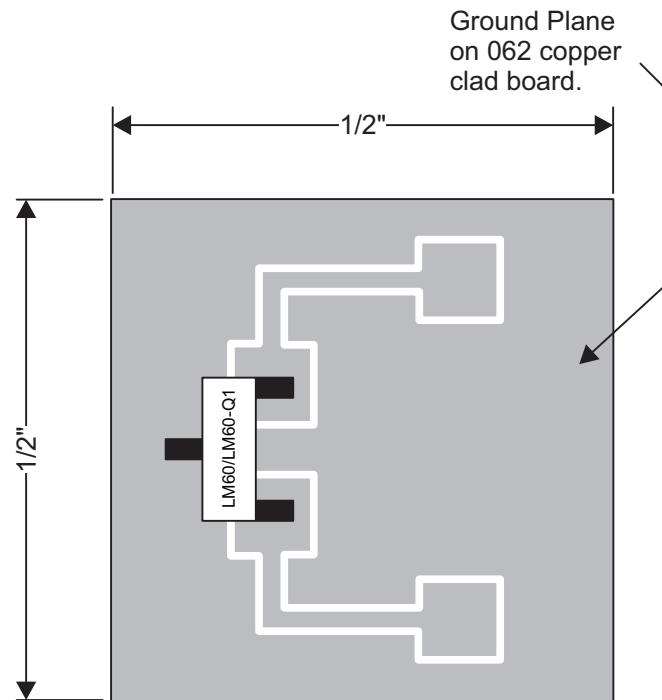

1/2-in Square Printed-Circuit Board with 2-oz. Copper Foil or Similar.

**Figure 20. Printed-Circuit Board Used for Heat Sink to Generate Thermal Response Curves**

## 12 器件和文档支持

### 12.1 接收文档更新通知

要接收文档更新通知，请转至 [TI.com](http://TI.com) 上的器件产品文件夹。单击右上角的 [通知我](#) 进行注册，即可每周接收产品信息更改摘要。有关更改的详细信息，请查看任何已修订文档中包含的修订历史记录。

### 12.2 社区资源

下列链接提供到 TI 社区资源的连接。链接的内容由各个分销商“按照原样”提供。这些内容并不构成 TI 技术规范，并且不一定反映 TI 的观点；请参阅 TI 的 [《使用条款》](#)。

**TI E2E™ 在线社区** [TI 的工程师对工程师 \(E2E\) 社区](#)。此社区的创建目的在于促进工程师之间的协作。在 [e2e.ti.com](http://e2e.ti.com) 中，您可以咨询问题、分享知识、拓展思路并与同行工程师一道帮助解决问题。

**设计支持** [TI 参考设计支持](#) 可帮助您快速查找有帮助的 E2E 论坛、设计支持工具以及技术支持的联系信息。

### 12.3 商标

E2E is a trademark of Texas Instruments.  
All other trademarks are the property of their respective owners.

### 12.4 静电放电警告



这些装置包含有限的内置 ESD 保护。存储或装卸时，应将导线一起截短或将装置放置于导电泡棉中，以防止 MOS 门极遭受静电损伤。

### 12.5 Glossary

[SLYZ022](#) — *TI Glossary*.

This glossary lists and explains terms, acronyms, and definitions.

## 13 机械、封装和可订购信息

以下页面包含机械、封装和可订购信息。这些信息是指定器件的最新可用数据。这些数据如有变更，恕不另行通知和修订此文档。如欲获取此数据表的浏览器版本，请参阅左侧的导航。



**PACKAGING INFORMATION**

Orderable Device	Status (1)	Package Type	Package Drawing	Pins	Package Qty	Eco Plan (2)	Lead finish/ Ball material (6)	MSL Peak Temp (3)	Op Temp (°C)	Device Marking (4/5)	Samples
LM60BIM3	NRND	SOT-23	DBZ	3	1000	Non-RoHS & Green	Call TI	Level-1-260C-UNLIM	-25 to 125	T6B	
LM60BIM3X	NRND	SOT-23	DBZ	3	3000	Non-RoHS & Green	Call TI	Level-1-260C-UNLIM	-25 to 125	T6B	
LM60BIM3X/NOPB	ACTIVE	SOT-23	DBZ	3	3000	RoHS & Green	SN	Level-1-260C-UNLIM	-25 to 125	T6B	Samples
LM60BIZ/LFT3	ACTIVE	TO-92	LP	3	2000	RoHS & Green	SN	N / A for Pkg Type		LM60 BIZ	Samples
LM60BIZ/NOPB	ACTIVE	TO-92	LP	3	1800	RoHS & Green	Call TI	N / A for Pkg Type	-25 to 125	LM60 BIZ	Samples
LM60CIM3	NRND	SOT-23	DBZ	3	1000	Non-RoHS & Green	Call TI	Level-1-260C-UNLIM	-40 to 125	T6C	
LM60CIM3X	NRND	SOT-23	DBZ	3	3000	Non-RoHS & Green	Call TI	Level-1-260C-UNLIM	-40 to 125	T6C	
LM60CIM3X/NOPB	ACTIVE	SOT-23	DBZ	3	3000	RoHS & Green	SN	Level-1-260C-UNLIM	-40 to 125	T6C	Samples
LM60CIZ/NOPB	ACTIVE	TO-92	LP	3	1800	RoHS & Green	Call TI	N / A for Pkg Type	-40 to 125	LM60 CIZ	Samples

(1) The marketing status values are defined as follows:

**ACTIVE:** Product device recommended for new designs.

**LIFEBUY:** TI has announced that the device will be discontinued, and a lifetime-buy period is in effect.

**NRND:** Not recommended for new designs. Device is in production to support existing customers, but TI does not recommend using this part in a new design.

**PREVIEW:** Device has been announced but is not in production. Samples may or may not be available.

**OBSELETE:** TI has discontinued the production of the device.

(2) **RoHS:** TI defines "RoHS" to mean semiconductor products that are compliant with the current EU RoHS requirements for all 10 RoHS substances, including the requirement that RoHS substance do not exceed 0.1% by weight in homogeneous materials. Where designed to be soldered at high temperatures, "RoHS" products are suitable for use in specified lead-free processes. TI may reference these types of products as "Pb-Free".

**RoHS Exempt:** TI defines "RoHS Exempt" to mean products that contain lead but are compliant with EU RoHS pursuant to a specific EU RoHS exemption.

**Green:** TI defines "Green" to mean the content of Chlorine (Cl) and Bromine (Br) based flame retardants meet JS709B low halogen requirements of <=1000ppm threshold. Antimony trioxide based flame retardants must also meet the <=1000ppm threshold requirement.

(3) MSL, Peak Temp. - The Moisture Sensitivity Level rating according to the JEDEC industry standard classifications, and peak solder temperature.

- (4) There may be additional marking, which relates to the logo, the lot trace code information, or the environmental category on the device.
- (5) Multiple Device Markings will be inside parentheses. Only one Device Marking contained in parentheses and separated by a "~" will appear on a device. If a line is indented then it is a continuation of the previous line and the two combined represent the entire Device Marking for that device.
- (6) Lead finish/Ball material - Orderable Devices may have multiple material finish options. Finish options are separated by a vertical ruled line. Lead finish/Ball material values may wrap to two lines if the finish value exceeds the maximum column width.

**Important Information and Disclaimer:**The information provided on this page represents TI's knowledge and belief as of the date that it is provided. TI bases its knowledge and belief on information provided by third parties, and makes no representation or warranty as to the accuracy of such information. Efforts are underway to better integrate information from third parties. TI has taken and continues to take reasonable steps to provide representative and accurate information but may not have conducted destructive testing or chemical analysis on incoming materials and chemicals. TI and TI suppliers consider certain information to be proprietary, and thus CAS numbers and other limited information may not be available for release.

In no event shall TI's liability arising out of such information exceed the total purchase price of the TI part(s) at issue in this document sold by TI to Customer on an annual basis.

**OTHER QUALIFIED VERSIONS OF LM60 :**

- Automotive : [LM60-Q1](#)

NOTE: Qualified Version Definitions:

- Automotive - Q100 devices qualified for high-reliability automotive applications targeting zero defects

**TAPE AND REEL INFORMATION**

**QUADRANT ASSIGNMENTS FOR PIN 1 ORIENTATION IN TAPE**

\*All dimensions are nominal

Device	Package Type	Package Drawing	Pins	SPQ	Reel Diameter (mm)	Reel Width W1 (mm)	A0 (mm)	B0 (mm)	K0 (mm)	P1 (mm)	W (mm)	Pin1 Quadrant
LM60BIM3	SOT-23	DBZ	3	1000	178.0	8.4	3.3	2.9	1.22	4.0	8.0	Q3
LM60BIM3X	SOT-23	DBZ	3	3000	178.0	8.4	3.3	2.9	1.22	4.0	8.0	Q3
LM60BIM3X/NOPB	SOT-23	DBZ	3	3000	178.0	8.4	3.3	2.9	1.22	4.0	8.0	Q3
LM60CIM3	SOT-23	DBZ	3	1000	178.0	8.4	3.3	2.9	1.22	4.0	8.0	Q3
LM60CIM3X	SOT-23	DBZ	3	3000	178.0	8.4	3.3	2.9	1.22	4.0	8.0	Q3
LM60CIM3X/NOPB	SOT-23	DBZ	3	3000	178.0	8.4	3.3	2.9	1.22	4.0	8.0	Q3

**TAPE AND REEL BOX DIMENSIONS**

\*All dimensions are nominal

Device	Package Type	Package Drawing	Pins	SPQ	Length (mm)	Width (mm)	Height (mm)
LM60BIM3	SOT-23	DBZ	3	1000	208.0	191.0	35.0
LM60BIM3X	SOT-23	DBZ	3	3000	208.0	191.0	35.0
LM60BIM3X/NOPB	SOT-23	DBZ	3	3000	208.0	191.0	35.0
LM60CIM3	SOT-23	DBZ	3	1000	208.0	191.0	35.0
LM60CIM3X	SOT-23	DBZ	3	3000	208.0	191.0	35.0
LM60CIM3X/NOPB	SOT-23	DBZ	3	3000	208.0	191.0	35.0

## GENERIC PACKAGE VIEW

LP 3

TO-92 - 5.34 mm max height

TRANSISTOR OUTLINE



Images above are just a representation of the package family, actual package may vary.  
Refer to the product data sheet for package details.

4040001-2/F

LP0003A



# PACKAGE OUTLINE

TO-92 - 5.34 mm max height

TO-92



4215214/B 04/2017

### NOTES:

1. All linear dimensions are in millimeters. Any dimensions in parenthesis are for reference only. Dimensioning and tolerancing per ASME Y14.5M.
2. This drawing is subject to change without notice.
3. Lead dimensions are not controlled within this area.
4. Reference JEDEC TO-226, variation AA.
5. Shipping method:
  - a. Straight lead option available in bulk pack only.
  - b. Formed lead option available in tape and reel or ammo pack.
  - c. Specific products can be offered in limited combinations of shipping medium and lead options.
  - d. Consult product folder for more information on available options.

# EXAMPLE BOARD LAYOUT

LP0003A

TO-92 - 5.34 mm max height

TO-92



LAND PATTERN EXAMPLE  
STRAIGHT LEAD OPTION  
NON-SOLDER MASK DEFINED  
SCALE:15X



LAND PATTERN EXAMPLE  
FORMED LEAD OPTION  
NON-SOLDER MASK DEFINED  
SCALE:15X

4215214/B 04/2017

# TAPE SPECIFICATIONS

LP0003A

TO-92 - 5.34 mm max height

TO-92



FOR FORMED LEAD OPTION PACKAGE

4215214/B 04/2017



# DBZ0003A



# PACKAGE OUTLINE

SOT-23 - 1.12 mm max height

SMALL OUTLINE TRANSISTOR

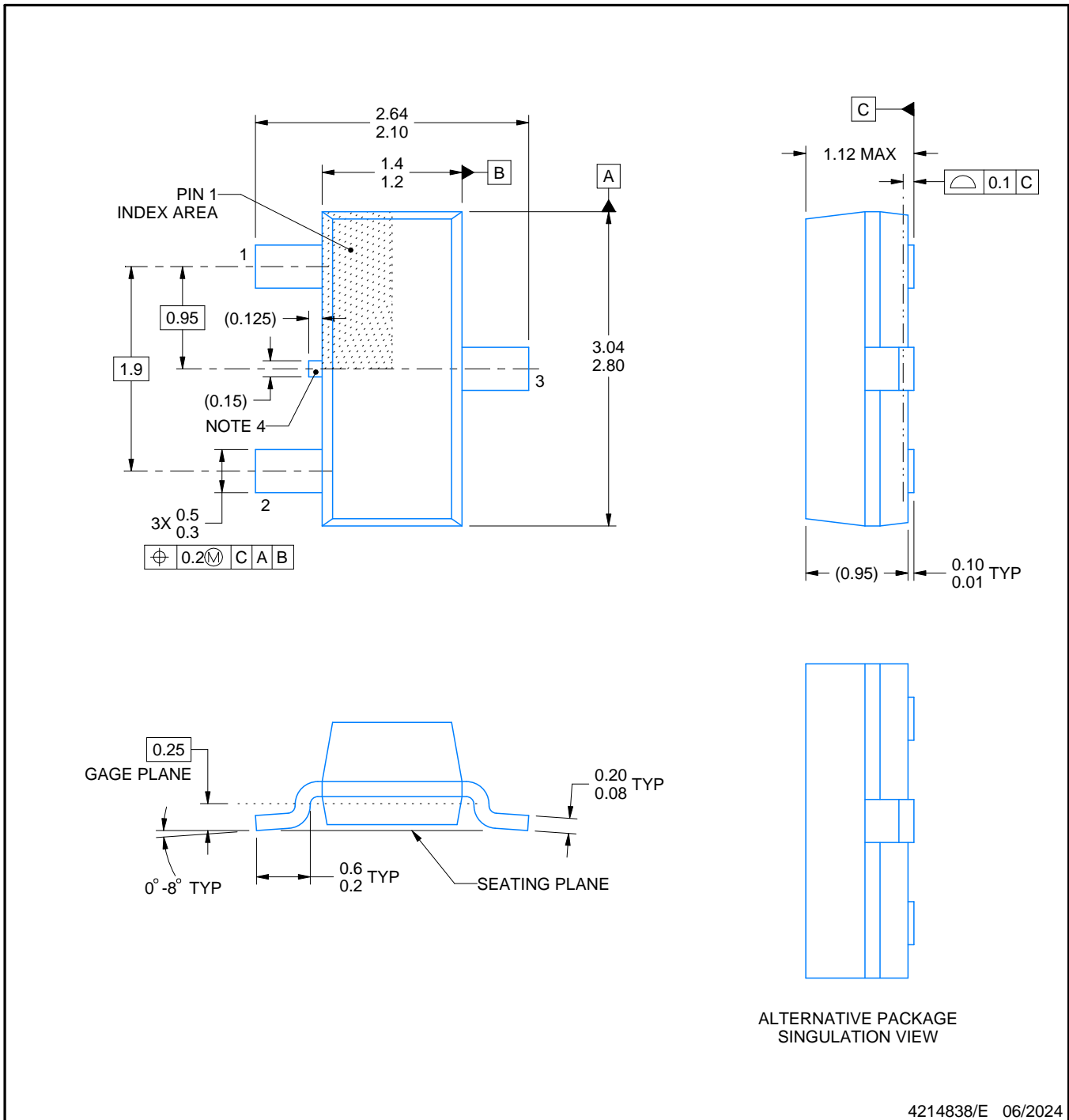

4214838/E 06/2024

# EXAMPLE BOARD LAYOUT

DBZ0003A

SOT-23 - 1.12 mm max height

SMALL OUTLINE TRANSISTOR

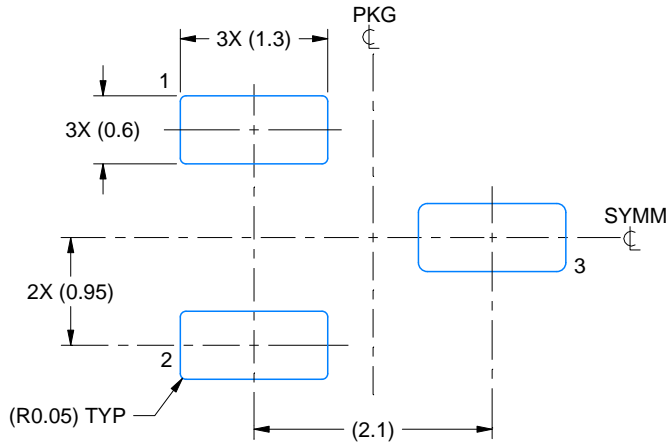

LAND PATTERN EXAMPLE  
SCALE:15X

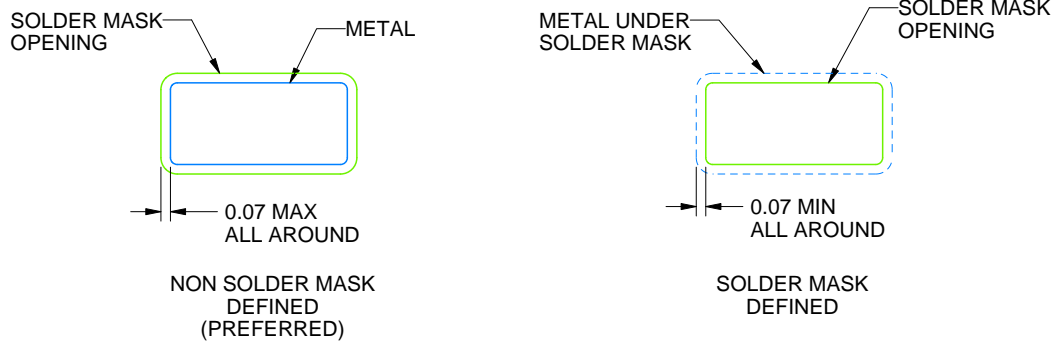

SOLDER MASK DETAILS

4214838/E 06/2024

NOTES: (continued)

5. Publication IPC-7351 may have alternate designs.
6. Solder mask tolerances between and around signal pads can vary based on board fabrication site.

# EXAMPLE STENCIL DESIGN

DBZ0003A

SOT-23 - 1.12 mm max height

SMALL OUTLINE TRANSISTOR

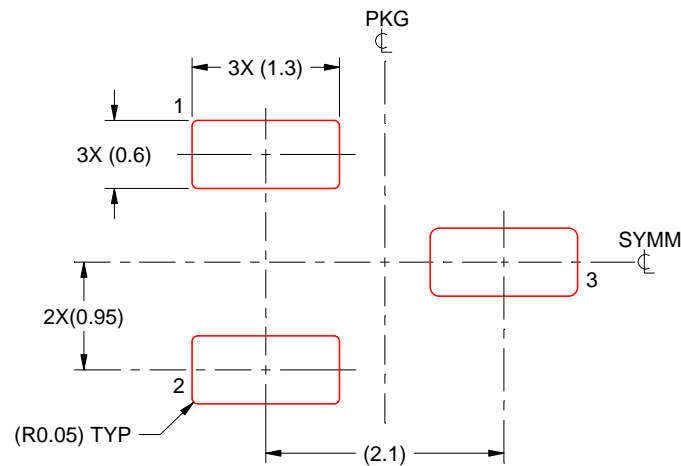

SOLDER PASTE EXAMPLE  
BASED ON 0.125 THICK STENCIL  
SCALE:15X

4214838/E 06/2024

NOTES: (continued)

7. Laser cutting apertures with trapezoidal walls and rounded corners may offer better paste release. IPC-7525 may have alternate design recommendations.
8. Board assembly site may have different recommendations for stencil design.

## 重要声明和免责声明

TI“按原样”提供技术和可靠性数据（包括数据表）、设计资源（包括参考设计）、应用或其他设计建议、网络工具、安全信息和其他资源，不保证没有瑕疵且不做任何明示或暗示的担保，包括但不限于对适销性、某特定用途方面的适用性或不侵犯任何第三方知识产权的暗示担保。

这些资源可供使用 TI 产品进行设计的熟练开发人员使用。您将自行承担以下全部责任：(1) 针对您的应用选择合适的 TI 产品，(2) 设计、验证并测试您的应用，(3) 确保您的应用满足相应标准以及任何其他功能安全、信息安全、监管或其他要求。

这些资源如有变更，恕不另行通知。TI 授权您仅可将这些资源用于研发本资源所述的 TI 产品的应用。严禁对这些资源进行其他复制或展示。您无权使用任何其他 TI 知识产权或任何第三方知识产权。您应全额赔偿因在这些资源的使用中对 TI 及其代表造成的任何索赔、损害、成本、损失和债务，TI 对此概不负责。

TI 提供的产品受 [TI 的销售条款](#) 或 [ti.com](#) 上其他适用条款/TI 产品随附的其他适用条款的约束。TI 提供这些资源并不会扩展或以其他方式更改 TI 针对 TI 产品发布的适用的担保或担保免责声明。

TI 反对并拒绝您可能提出的任何其他或不同的条款。

邮寄地址：Texas Instruments, Post Office Box 655303, Dallas, Texas 75265  
Copyright © 2024，德州仪器 (TI) 公司