

采用 QFN 封装且具有 2.95V 至 14.5V 输入和电流共享的 LMZ31506 6A 电源模块

1 特性

- 完整的集成式电源解决方案可实现小尺寸和扁平设计
- 9mm × 15mm × 2.8mm 封装
 - 引脚与 LMZ31503 兼容
- 效率高达 96%
- 宽输出电压调节范围
 - 0.6V 至 5.5V，基准精度为 1%
- 支持针对更高电流的并联运行
- 可选分离电源轨可实现低至 1.6V 的输入电压
- 可调开关频率
 - (250kHz 至 780kHz)
- 与外部时钟同步
- 可调慢速启动
- 输出电压排序/跟踪
- 电源正常输出
- 可编程欠压锁定 (UVLO)
- 输出过流保护 (断续模式)
- 过温保护
- 预偏置输出启动
- 运行温度范围: -40°C 至 85°C
- 增强的热性能: 13°C/W
- 符合 EN55022 B 类辐射标准
 - 集成屏蔽电感器
- 使用 LMZ31506 并借助 WEBENCH® 电源设计器创建定制设计方案

2 应用

- 宽带和通信基础设施
- 自动化测试和医疗设备
- 紧凑型外设组件互连接口 (PCI)，PCI 快速接口和 PCI 扩展 (PXI) 快速接口
- DSP 和 FPGA 负载点应用

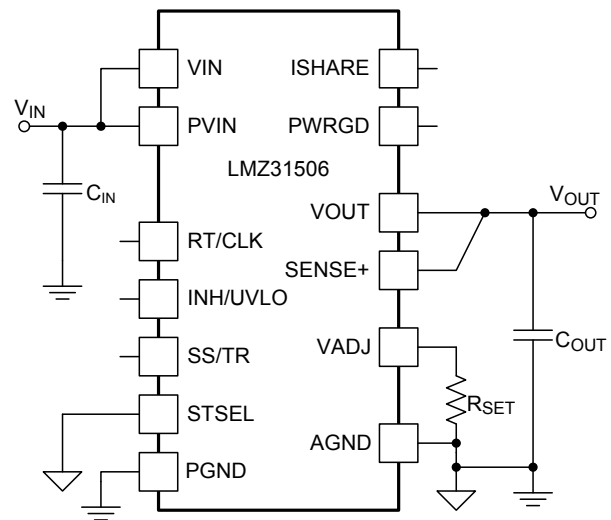
3 说明

LMZ31506 电源模块是一款易于使用的集成式电源解决方案，它在一个扁平的 QFN 封装内整合了一个带有功率 MOSFET 的 6A 直流/直流转换器、一个屏蔽式电感器和多个无源器件。此整体电源解决方案仅需三个外部组件，并省去了环路补偿和磁性元件选择过程。

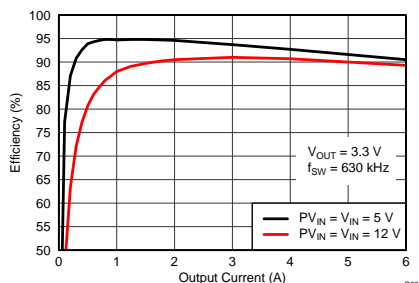
9mm × 15mm × 2.8 mm QFN 封装能轻松焊接到印制电路板上，并且可实现效率高于 90% 的紧凑型负载点设计以及结至环境的热阻抗仅为 13°C/W 的出色功率耗散。在环境温度为 85°C 且无气流的情况下，该器件可提供 6A 的满额输出电流。

LMZ31506 提供了分离式负载点设计的灵活性和功能集，非常适合为高性能 DSP 和 FPGA 供电。先进的封装技术可提供一个与标准 QFN 贴装和测试技术兼容的耐用且可靠的电源解决方案。

简化应用



效率



4 Specifications

4.1 Absolute Maximum Ratings⁽¹⁾

over operating temperature range (unless otherwise noted)

		VALUE		UNIT
		MIN	MAX	
Input Voltage	VIN, PVIN, INH/UVLO	–0.3	16	V
	PWRGD, RT/CLK	–0.3	6	V
	VADJ, SS/TR, STSEL, ISHARE	–0.3	3	V
Output Voltage	PH	–1	20	V
	PH 10ns Transient	–3	20	V
V _{DIFF} (GND to exposed thermal pad)		–0.2	0.2	V
Source Current	RT/CLK	–100	+100	μA
	PH		Current Limit	A
Sink Current	PH		Current Limit	A
	PVIN		Current Limit	A
	PWRGD	–0.1	5	mA
Operating Junction Temperature		–40	125 ⁽²⁾	°C
Storage Temperature		–65	150	°C
Peak Reflow Case Temperature ⁽³⁾			245 ⁽⁴⁾	°C
Maximum Number of Reflows Allowed ⁽³⁾			3 ⁽⁴⁾	
Mechanical Shock	Mil-STD-883D, Method 2002.3, 1 msec, 1/2 sine, mounted		1500	G
Mechanical Vibration	Mil-STD-883D, Method 2007.2, 20-2000Hz		20	

(1) Stresses beyond those listed under absolute maximum ratings may cause permanent damage to the device. These are stress ratings only, and functional operation of the device at these or any other conditions beyond those indicated under recommended operating conditions is not implied. Exposure to absolute-maximum-rated conditions for extended periods may affect device reliability.

(2) See the temperature derating curves in the Typical Characteristics section for thermal information.

(3) For soldering specifications, refer to the [Soldering Requirements for BQFN Packages](#) application note.

(4) Devices with a date code prior to week 14 2018 (1814) have a peak reflow case temperature of 240°C with a maximum of one reflow.

4.2 Thermal Information

THERMAL METRIC ⁽¹⁾		LMZ31506	UNIT
		RUQ47	
		47 PINS	
θ_{JA}	Junction-to-ambient thermal resistance ⁽²⁾	13	°C/W
$\theta_{Jc\text{top}}$	Junction-to-case (top) thermal resistance ⁽³⁾	9	°C/W
$\theta_{Jc\text{bot}}$	Junction-to-case (bottom) thermal resistance ⁽⁴⁾	3.8	°C/W
θ_{JB}	Junction-to-board thermal resistance ⁽⁵⁾	6	°C/W
ψ_{JT}	Junction-to-top characterization parameter ⁽⁶⁾	2.5	°C/W
ψ_{JB}	Junction-to-board characterization parameter ⁽⁷⁾	5	°C/W

- (1) For more information about traditional and new thermal metrics, see the [Semiconductor and IC Package Thermal Metrics](#) application report, [SPRA953](#).
- (2) The junction-to-ambient thermal resistance, θ_{JA} , applies to devices soldered directly to a 100 mm x 100 mm double-sided PCB with 1 oz. copper and natural convection cooling. Additional airflow reduces θ_{JA} .
- (3) The junction-to-case (top) thermal resistance is obtained by simulating a cold plate test on the package top. No specific JEDEC standard test exists, but a close description can be found in the ANSI SEMI standard G30-88.
- (4) The junction-to-case (bottom) thermal resistance is obtained by simulating a cold plate test on the exposed (power) pad. No specific JEDEC standard test exists, but a close description can be found in the ANSI SEMI standard G30-88.
- (5) The junction-to-board thermal resistance is obtained by simulating in an environment with a ring cold plate fixture to control the PCB temperature, as described in JESD51-8.
- (6) The junction-to-top characterization parameter, ψ_{JT} , estimates the junction temperature, T_J , of a device in a real system, using a procedure described in JESD51-2A (sections 6 and 7). $T_J = \psi_{JT} * P_{\text{dis}} + T_T$; where P_{dis} is the power dissipated in the device and T_T is the temperature of the top of the device.
- (7) The junction-to-board characterization parameter, ψ_{JB} , estimates the junction temperature, T_J , of a device in a real system, using a procedure described in JESD51-2A (sections 6 and 7). $T_J = \psi_{JB} * P_{\text{dis}} + T_B$; where P_{dis} is the power dissipated in the device and T_B is the temperature of the board 1mm from the device.

4.3 Package Specifications

LMZ31506		UNIT
Weight		1.26 grams
Flammability	Meets UL 94 V-O	
MTBF Calculated reliability	Per Bellcore TR-332, 50% stress, $T_A = 40^\circ\text{C}$, ground benign	33.9 Mhrs

4.4 Electrical Characteristics

Over -40°C to 85°C free-air temperature, $P_{\text{VIN}} = V_{\text{IN}} = 12\text{ V}$, $V_{\text{OUT}} = 1.8\text{ V}$, $I_{\text{OUT}} = 6\text{ A}$,
 $C_{\text{IN}1} = 2 \times 22\ \mu\text{F}$ ceramic, $C_{\text{IN}2} = 68\ \mu\text{F}$ poly-tantalum, $C_{\text{OUT}1} = 4 \times 47\ \mu\text{F}$ ceramic (unless otherwise noted)

PARAMETER	TEST CONDITIONS	MIN	TYP	MAX	UNIT		
I_{OUT}	Output current	$T_A = 85^\circ\text{C}$, natural convection			6	A	
V_{IN}	Input bias voltage range	Over I_{OUT} range			4.5	14.5	V
P_{VIN}	Input switching voltage range	Over I_{OUT} range			1.6 ⁽¹⁾	14.5 ⁽²⁾	V
UV_{LO}	V_{IN} Undervoltage lockout	VIN = increasing		4.0	4.5	V	
		VIN = decreasing		3.5	3.85		
$V_{\text{OUT(adj)}}$	Output voltage adjust range	Over I_{OUT} range			0.6 ⁽²⁾	5.5	V
V_{OUT}	Set-point voltage tolerance	$T_A = 25^\circ\text{C}$, $I_{\text{OUT}} = 0\text{ A}$			$\pm 1.0\%$ ⁽³⁾		
	Temperature variation	$-40^\circ\text{C} \leq T_A \leq +85^\circ\text{C}$, $I_{\text{OUT}} = 0\text{ A}$			$\pm 0.3\%$		
	Line regulation	Over P_{VIN} range, $T_A = 25^\circ\text{C}$, $I_{\text{OUT}} = 0\text{ A}$			$\pm 0.1\%$		
	Load regulation	Over I_{OUT} range, $T_A = 25^\circ\text{C}$			$\pm 0.1\%$		
	Total output voltage variation	Includes set-point, line, load, and temperature variation			$\pm 1.5\%$ ⁽³⁾		

- (1) The minimum P_{VIN} voltage is 1.6V or ($V_{\text{OUT}} + 0.9\text{V}$), whichever is greater. V_{IN} must be greater than 4.5V.
- (2) The maximum P_{VIN} voltage is 14.5V or ($15 \times V_{\text{OUT}}$), whichever is less.
- (3) The stated limit of the set-point voltage tolerance includes the tolerance of both the internal voltage reference and the internal adjustment resistor. The overall output voltage tolerance will be affected by the tolerance of the external R_{SET} resistor.

Electrical Characteristics (continued)

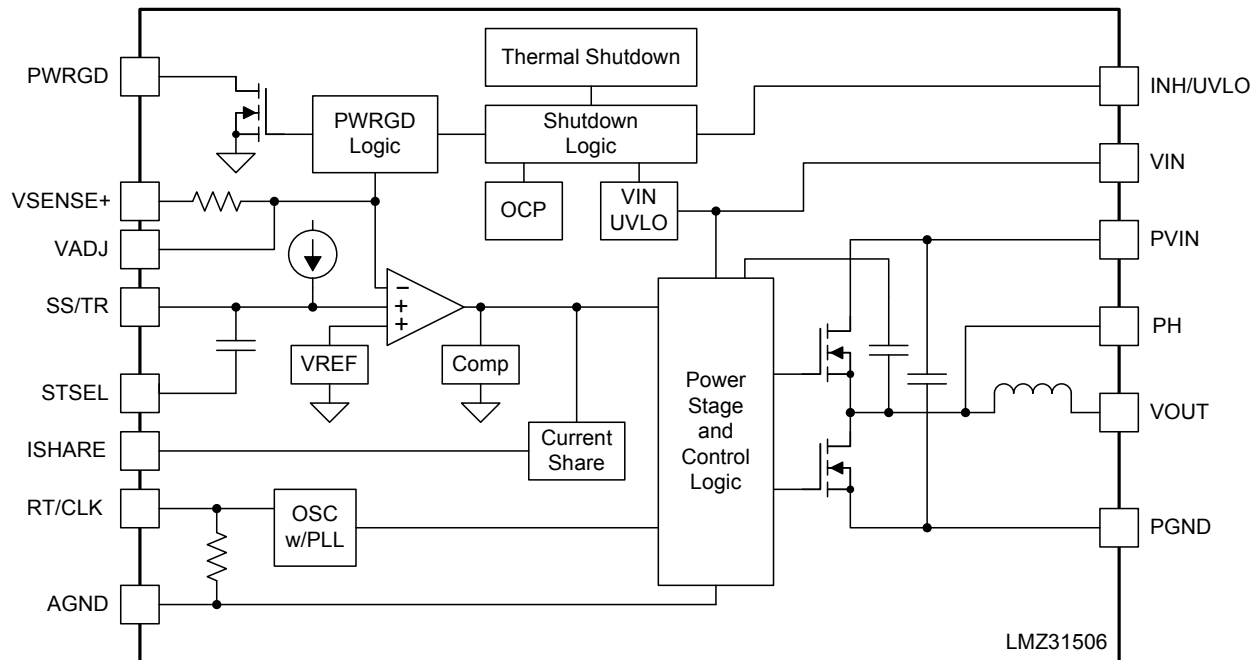
Over -40°C to 85°C free-air temperature, $\text{PVIN} = \text{VIN} = 12\text{ V}$, $\text{V}_{\text{OUT}} = 1.8\text{ V}$, $\text{I}_{\text{OUT}} = 6\text{ A}$,
 $\text{C}_{\text{IN}1} = 2 \times 22\text{ }\mu\text{F}$ ceramic, $\text{C}_{\text{IN}2} = 68\text{ }\mu\text{F}$ poly-tantalum, $\text{C}_{\text{OUT}1} = 4 \times 47\text{ }\mu\text{F}$ ceramic (unless otherwise noted)

PARAMETER	TEST CONDITIONS		MIN	TYP	MAX	UNIT	
η Efficiency	PVIN = VIN = 12 V I _O = 2 A	V _{OUT} = 5 V, f _{SW} = 780 kHz		92 %			
		V _{OUT} = 3.3 V, f _{SW} = 630 kHz		91 %			
		V _{OUT} = 2.5 V, f _{SW} = 530 kHz		89 %			
		V _{OUT} = 1.8 V, f _{SW} = 480 kHz		88 %			
		V _{OUT} = 1.2 V, f _{SW} = 480 kHz		85 %			
		V _{OUT} = 0.8 V, f _{SW} = 480 kHz		80 %			
	PVIN = VIN = 5 V I _O = 2 A	V _{OUT} = 3.3V, f _{SW} = 630 kHz		95 %			
		V _{OUT} = 2.5V, f _{SW} = 530 kHz		93 %			
		V _{OUT} = 1.8V, f _{SW} = 480 kHz		91 %			
		V _{OUT} = 1.2V, f _{SW} = 480 kHz		89 %			
		V _{OUT} = 0.8V, f _{SW} = 480 kHz		85 %			
		V _{OUT} = 0.6V, f _{SW} = 250 kHz		83 %			
Output voltage ripple	20 MHz bandwidth			30		mV _{PP}	
I _{LIM} Overcurrent threshold				11		A	
Transient response	1.0 A/ μs load step from 50 to 100% I _{OUT(max)}	Recovery time		80		μs	
		V _{OUT} over/undershoot		60		mV	
V _{INH-H} Inhibit Control	Inhibit High Voltage		1.30	Open ⁽⁴⁾		V	
V _{INH-L} Inhibit Control	Inhibit Low Voltage		-0.3	1.05		V	
INH Input current	INH < 1.1 V			-1.15		μA	
INH Hysteresis current	INH > 1.26 V			-3.4		μA	
I _{I(stby)} Input standby current	INH pin to AGND			2	4	μA	
Power Good	PWRGD Thresholds	V _{OUT} rising	Good	94%			
			Fault	109%			
	V _{OUT} falling	Fault	91%				
		Good	106%				
PWRGD Low Voltage	I(PWRGD) = 2 mA			0.3	V		
f _{SW} Switching frequency	Over VIN and I _{OUT} ranges, RT/CLK pin OPEN		200	250	300	kHz	
f _{CLK} Synchronization frequency	CLK Control			250	780	kHz	
V _{CLK-H} CLK High-Level				2.0	5.5	V	
V _{CLK-L} CLK Low-Level					0.8	V	
D _{CLK} CLK Duty cycle				20%	80%		
Thermal Shutdown	Thermal shutdown		160	175		$^{\circ}\text{C}$	
	Thermal shutdown hysteresis			10		$^{\circ}\text{C}$	
C _{IN} External input capacitance		Ceramic	44 ⁽⁵⁾			μF	
		Non-ceramic	68 ⁽⁵⁾				
C _{OUT} External output capacitance		Ceramic	47 ⁽⁶⁾	200	1500	μF	
		Non-ceramic		220 ⁽⁶⁾	5000		
		Equivalent series resistance (ESR)			35	m Ω	

- (4) This control pin has an internal pullup. If this pin is left open circuit, the device operates when input power is applied. A small low-leakage MOSFET is recommended for control. See the application section for further guidance.
- (5) A minimum of 100 μF of polymer tantalum and/or ceramic external capacitance is required across the input (VIN and PVIN connected) for proper operation. Locate the capacitor close to the device. See [Table 4](#) for more details. When operating with split VIN and PVIN rails, place 4.7 μF of ceramic capacitance directly at the VIN pin.
- (6) The amount of required output capacitance varies depending on the output voltage (see [Table 3](#)). The amount of required capacitance must include at least 1x 47 μF ceramic capacitor. Locate the capacitance close to the device. Adding additional capacitance close to the load improves the response of the regulator to load transients. See [Table 3](#) and [Table 4](#) more details.

5 Device Information

Functional Block Diagram



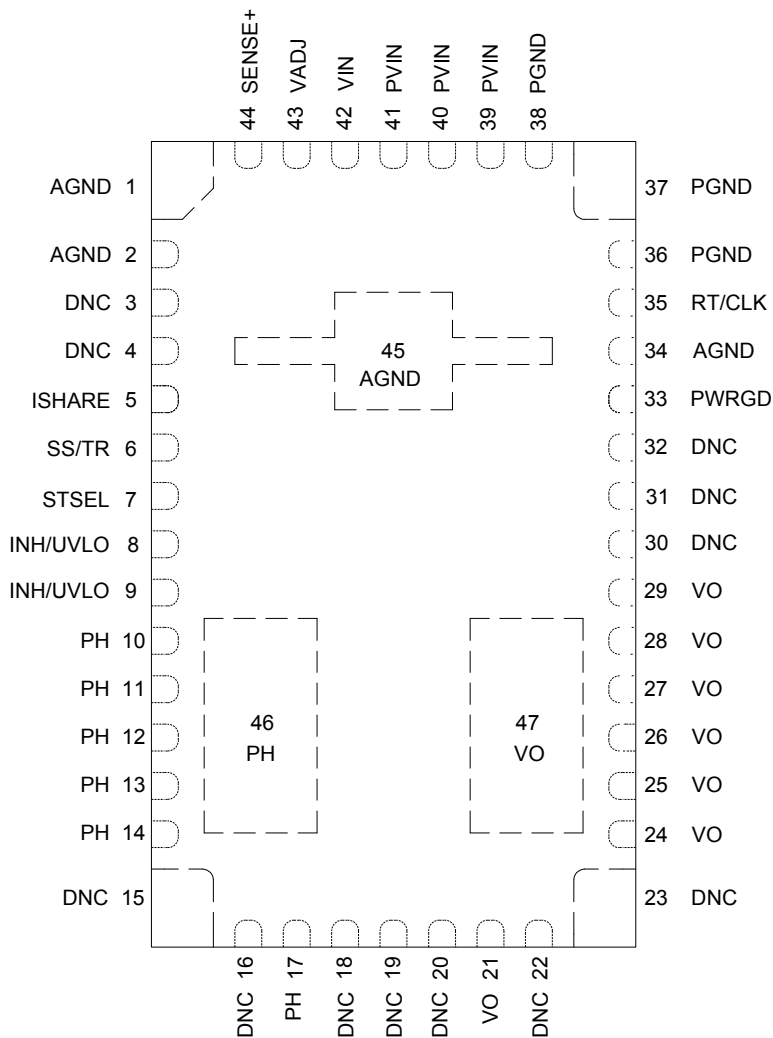
Pin Descriptions

TERMINAL		DESCRIPTION
NAME	NO.	
AGND	1	Zero VDC reference for the analog control circuitry. Connect AGND to PGND at a single point. Connect near the output capacitors. See Figure 43 for a recommended layout.
	2	
	34	
	45	
INH/UVLO	8	Inhibit and UVLO adjust pin. Use an open drain or open collector output logic to control the INH function. A resistor divider between this pin, AGND and VIN adjusts the UVLO voltage. Tie both pins together when using this control.
	9	
ISHARE	5	Current share pin. Connect this pin to other LMZ31506 device's ISHARE pin when paralleling multiple LMZ31506 devices. When unused, treat this pin as a Do Not Connect (DNC) and leave it isolated from all other signals or ground.
DNC	3	Do Not Connect. Do not connect these pins to AGND, to another DNC pin, or to any other voltage. These pins are connected to internal circuitry. Each pin must be soldered to an isolated pad.
	4	
	15	
	16	
	18	
	19	
	20	
	22	
	23	
	30	
	31	
PGND	36	Common ground connection for the PVIN, VIN, and VOUT power connections. See Figure 43 for a recommended layout.
	37	
	38	
PH	10	Phase switch node. These pins should be connected to a small copper island under the device for thermal relief. Do not connect any external component to this pin or tie it to a pin of another function.
	11	
	12	
	13	
	14	
	17	
PWRGD	33	Power good fault pin. Asserts low if the output voltage is out of range. A pull-up resistor is required.
	39	Input switching voltage. This pin supplies voltage to the power switches of the converter. See Figure 43 for a recommended layout.
PVIN	40	
	41	
RT/CLK	35	This pin automatically selects between RT mode and CLK mode. A timing resistor adjusts the switching frequency of the device. In CLK mode, the device synchronizes to an external clock.
SENSE+	44	Remote sense connection. Connect this pin to VOUT at the load for improved regulation. This pin must be connected to VOUT at the load, or at the module pins.
SS/TR	6	Slow-start and tracking pin. Connecting an external capacitor to this pin adjusts the output voltage rise time. A voltage applied to this pin allows for tracking and sequencing control.
STSEL	7	Slow-start or track feature select. Connect this pin to AGND to enable the internal SS capacitor with a SS interval of approximately 1.1 ms. Leave this pin open to enable the TR feature.
VADJ	43	Connecting a resistor between this pin and AGND sets the output voltage.
VIN	42	Input bias voltage pin. Supplies the control circuitry of the power converter. See Figure 43 for a recommended layout.

Pin Descriptions (continued)

TERMINAL		DESCRIPTION
NAME	NO.	
VOUT	21	Output voltage. Connect output capacitors between these pins and PGND.
	24	
	25	
	26	
	27	
	28	
	29	
	47	

**RUQ PACKAGE
47 PIN
TOP VIEW**



6 Typical Characteristics (PVIN = VIN = 12 V)

The electrical characteristic data has been developed from actual products tested at 25°C. This data is considered typical for the converter. Applies to Figure 1, Figure 2, and Figure 3. The temperature derating curves represent the conditions at which internal components are at or below the manufacturer's maximum operating temperatures. Derating limits apply to devices soldered directly to a 100 mm × 100 mm double-sided PCB with 1 oz. copper. Applies to Figure 4.

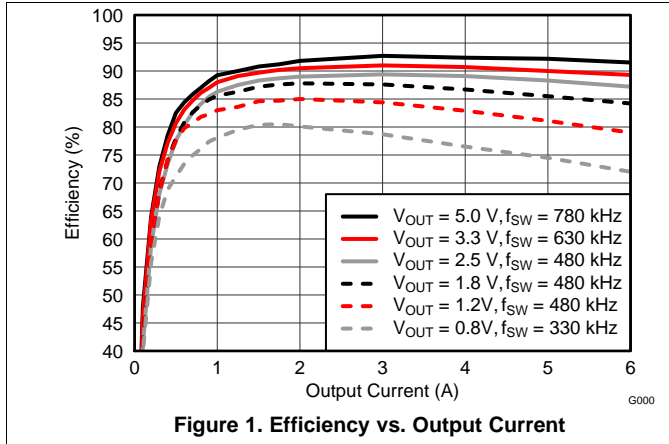


Figure 1. Efficiency vs. Output Current

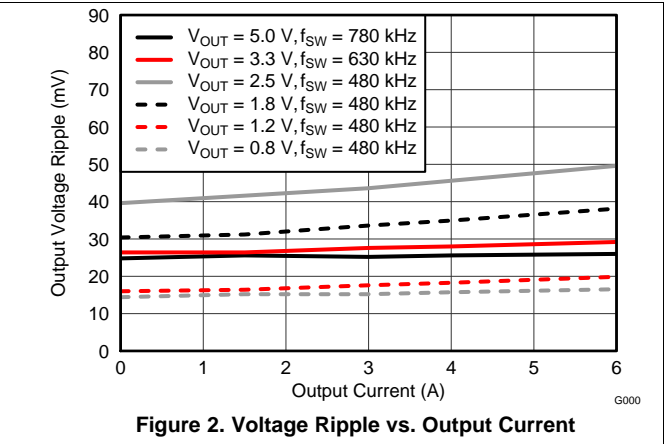


Figure 2. Voltage Ripple vs. Output Current

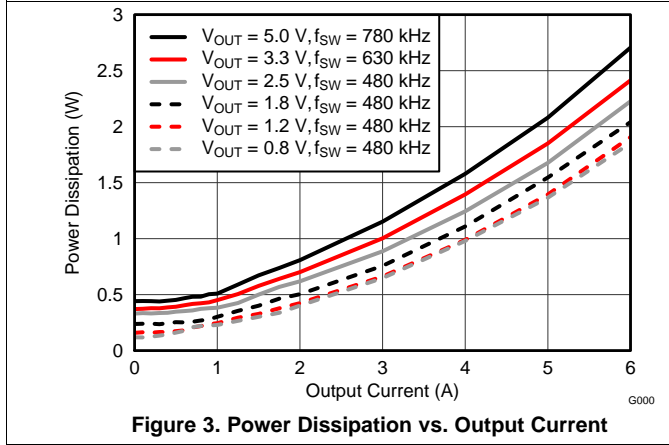


Figure 3. Power Dissipation vs. Output Current

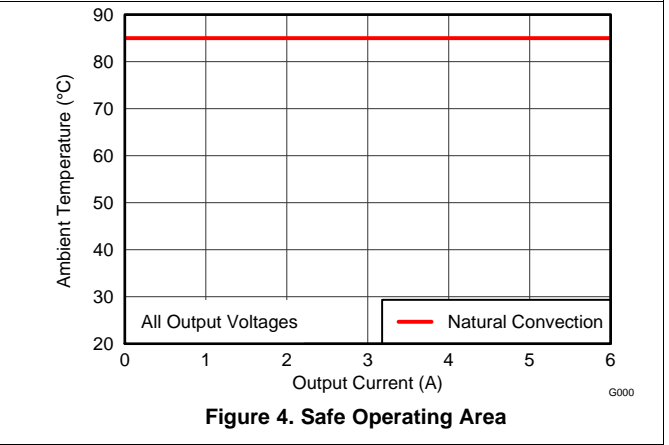


Figure 4. Safe Operating Area

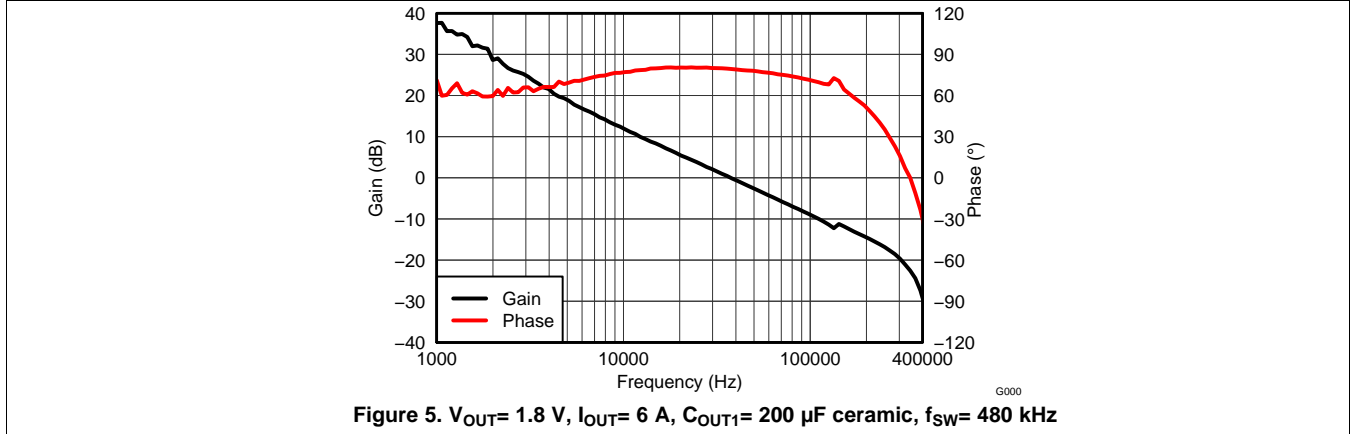


Figure 5. $V_{OUT} = 1.8 V$, $I_{OUT} = 6 A$, $C_{OUT1} = 200 \mu F$ ceramic, $f_{SW} = 480 kHz$

7 Typical Characteristics (PVIN = VIN = 5 V)

The electrical characteristic data has been developed from actual products tested at 25°C. This data is considered typical for the converter. Applies to Figure 6, Figure 7, and Figure 8. The temperature derating curves represent the conditions at which internal components are at or below the manufacturer's maximum operating temperatures. Derating limits apply to devices soldered directly to a 100 mm × 100 mm double-sided PCB with 1 oz. copper. Applies to Figure 9.

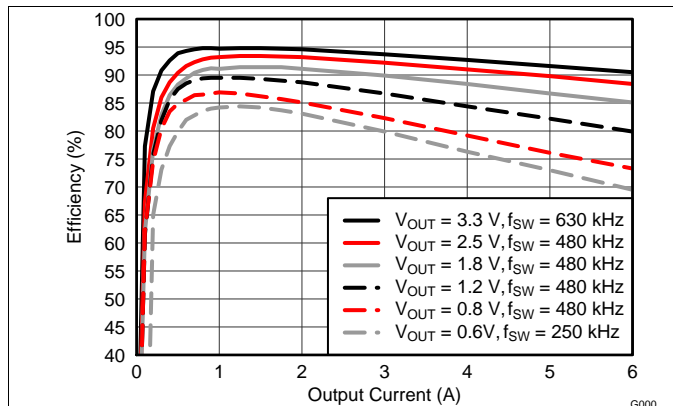


Figure 6. Efficiency vs. Output Current

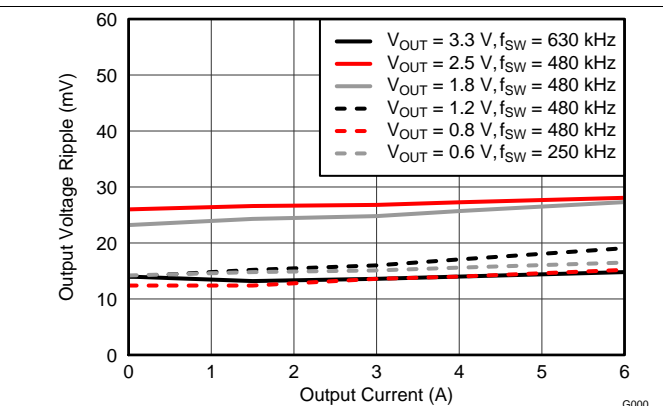


Figure 7. Voltage Ripple vs. Output Current

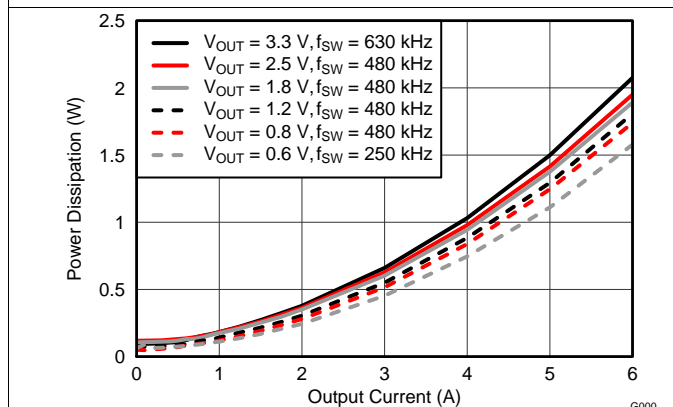


Figure 8. Power Dissipation vs. Output Current

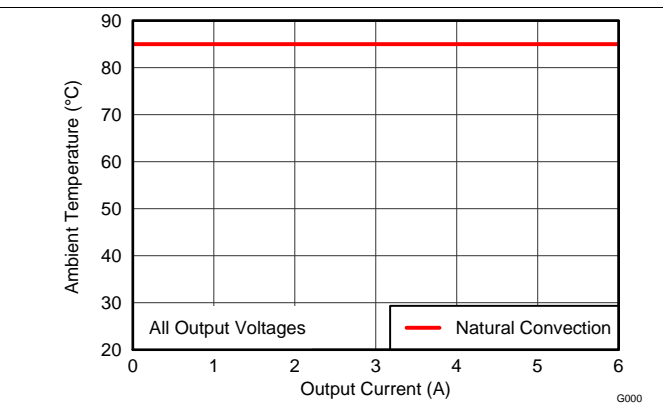


Figure 9. Safe Operating Area

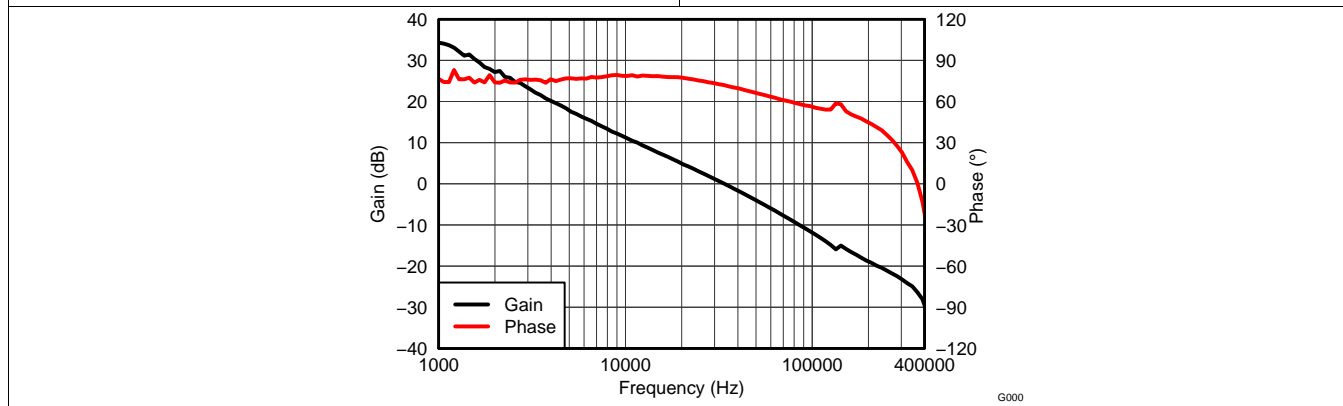


Figure 10. V_{OUT} = 1.8 V, I_{OUT} = 6 A, C_{OUT1} = 200 μF ceramic, f_{SW} = 480 kHz

8 Typical Characteristics (PVIN = 12 V, VIN = 5 V)

The electrical characteristic data has been developed from actual products tested at 25°C. This data is considered typical for the converter. Applies to Figure 11, Figure 12, and Figure 13. The temperature derating curves represent the conditions at which internal components are at or below the manufacturer's maximum operating temperatures. Derating limits apply to devices soldered directly to a 100 mm x 100 mm double-sided PCB with 1 oz. copper. Applies to Figure 14 and Figure 15.

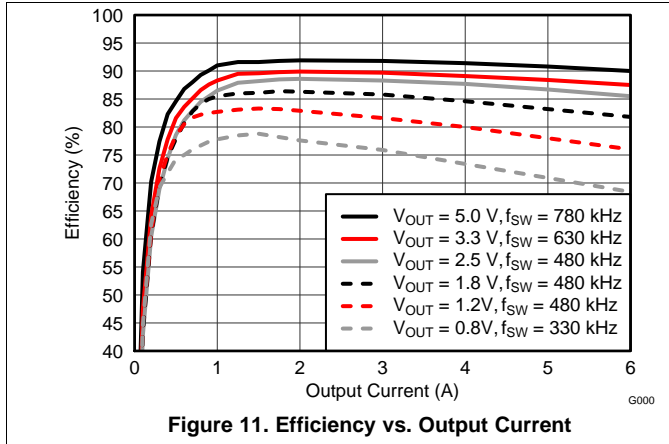


Figure 11. Efficiency vs. Output Current

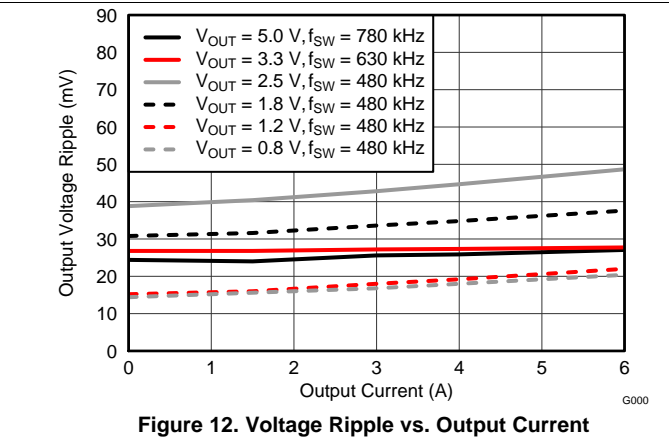


Figure 12. Voltage Ripple vs. Output Current

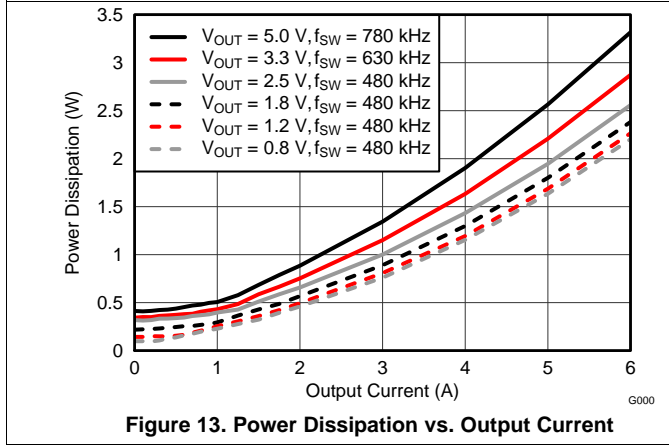


Figure 13. Power Dissipation vs. Output Current

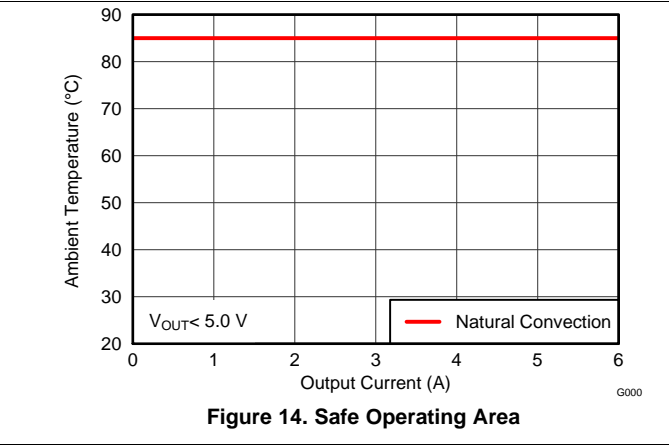


Figure 14. Safe Operating Area

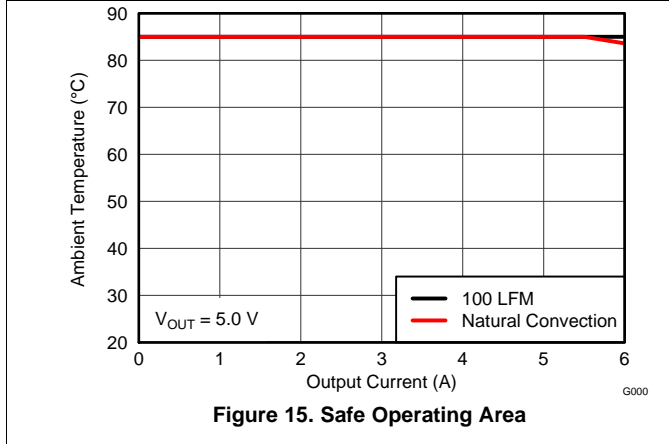


Figure 15. Safe Operating Area

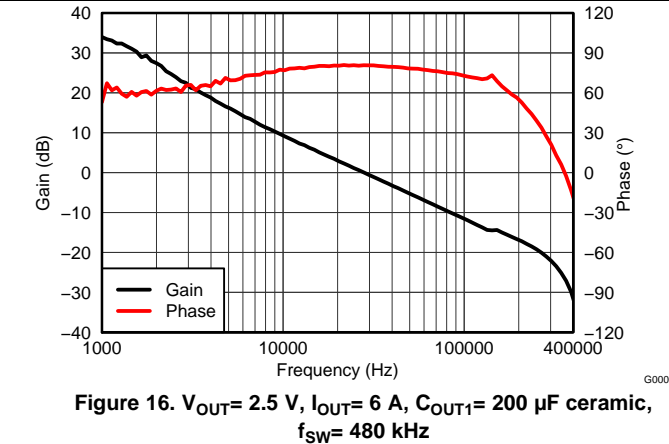


Figure 16. V_{OUT} = 2.5 V, I_{OUT} = 6 A, C_{OUT1} = 200 μF ceramic, f_{SW} = 480 kHz

9 Application Information

9.1 Adjusting the Output Voltage

The VADJ control sets the output voltage of the LMZ31506. The output voltage adjustment range is from 0.6 V to 5.5 V. The adjustment method requires the addition of R_{SET} , which sets the output voltage, the connection of SENSE+ to VOUT, and in some cases R_{RT} which sets the switching frequency. The R_{SET} resistor must be connected directly between the VADJ (pin 43) and AGND (pin 45). The SENSE+ pin (pin 44) must be connected to VOUT either at the load for improved regulation or at VOUT of the device. The R_{RT} resistor must be connected directly between the RT/CLK (pin 35) and AGND (pin 34). [Table 1](#) gives the standard external R_{SET} resistor for a number of common bus voltages, along with the required R_{RT} resistor for that output voltage.

Table 1. Standard R_{SET} Resistor Values for Common Output Voltages

RESISTORS	OUTPUT VOLTAGE V_{OUT} (V)						
	0.9	1.0	1.2	1.8	2.5	3.3	5.0
R_{SET} (k Ω)	2.87	2.15	1.43	0.715	0.453	0.316	0.196
R_{RT} (k Ω)	261	261	200	200	165	121	86.6

For other output voltages, the value of the required resistor can either be calculated using the following formula, or simply selected from the range of values given in [Table 2](#).

$$R_{SET} = \frac{1.43}{\left(\left(\frac{V_{OUT}}{0.6}\right) - 1\right)} \text{ (k}\Omega\text{)} \quad (1)$$

Table 2. Standard R_{SET} Resistor Values

V_{OUT} (V)	R_{SET} (k Ω)	R_{RT} (k Ω)	f_{sw} (kHz)	V_{OUT} (V)	R_{SET} (k Ω)	R_{RT} (k Ω)	f_{sw} (kHz)
0.6	open	open	250	3.1	0.348	140	580
0.7	8.66	590	330	3.2	0.332	140	580
0.8	4.32	590	330	3.3	0.316	121	630
0.9	2.87	261	430	3.4	0.309	121	630
1.0	2.15	261	430	3.5	0.294	121	630
1.1	1.74	261	430	3.6	0.287	121	630
1.2	1.43	200	480	3.7	0.280	121	630
1.3	1.24	200	480	3.8	0.267	107	680
1.4	1.07	200	480	3.9	0.261	107	680
1.5	0.953	200	480	4.0	0.255	107	680
1.6	0.866	200	480	4.1	0.243	107	680
1.7	0.787	200	480	4.2	0.237	95.3	730
1.8	0.715	200	480	4.3	0.232	95.3	730
1.9	0.665	200	480	4.4	0.226	95.3	730
2.0	0.619	200	480	4.5	0.221	95.3	730
2.1	0.576	200	480	4.6	0.215	95.3	730
2.2	0.536	200	480	4.7	0.210	95.3	730
2.3	0.511	200	480	4.8	0.205	86.6	780
2.4	0.475	200	480	4.9	0.200	86.6	780
2.5	0.453	200	480	5.0	0.196	86.6	780
2.6	0.432	165	530	5.1	0.191	86.6	780
2.7	0.412	165	530	5.2	0.187	86.6	780
2.8	0.392	165	530	5.3	0.182	86.6	780
2.9	0.374	165	530	5.4	0.178	86.6	780
3.0	0.357	140	580	5.5	0.174	86.6	780

9.2 Capacitor Recommendations for the LMZ31506 Power Supply

9.2.1 Capacitor Technologies

9.2.1.1 Electrolytic, Polymer-Electrolytic Capacitors

When using electrolytic capacitors, high-quality, computer-grade electrolytic capacitors are recommended. Polymer-electrolytic type capacitors are recommended for applications where the ambient operating temperature is less than 0°C. The Sanyo OS-CON capacitor series is suggested due to the lower ESR, higher rated surge, power dissipation, ripple current capability, and small package size. Aluminum electrolytic capacitors provide adequate decoupling over the frequency range of 2 kHz to 150 kHz, and are suitable when ambient temperatures are above 0°C.

9.2.1.2 Ceramic Capacitors

The performance of aluminum electrolytic capacitors is less effective than ceramic capacitors above 150 kHz. Multilayer ceramic capacitors have a low ESR and a resonant frequency higher than the bandwidth of the regulator. They can be used to reduce the reflected ripple current at the input as well as improve the transient response of the output.

9.2.1.3 Tantalum, Polymer-Tantalum Capacitors

Polymer-tantalum type capacitors are recommended for applications where the ambient operating temperature is less than 0°C. The Sanyo POSCAP series and Kemet T530 capacitor series are recommended rather than many other tantalum types due to their lower ESR, higher rated surge, power dissipation, ripple current capability, and small package size. Tantalum capacitors that have no stated ESR or surge current rating are not recommended for power applications.

9.2.2 Input Capacitor

The LMZ31506 requires a minimum input capacitance of 100 μF of ceramic and/or polymer-tantalum capacitors. The ripple current rating of the capacitor must be at least 450 mArms. [Table 4](#) includes a preferred list of capacitors by vendor.

9.2.3 Output Capacitor

The required output capacitance is determined by the output voltage of the LMZ31506. See [Table 3](#) for the amount of required capacitance. The required output capacitance must be comprised of all ceramic capacitors. When adding additional non-ceramic bulk capacitors, low-ESR devices like the ones recommended in [Table 4](#) are required. The required capacitance above the minimum is determined by actual transient deviation requirements. See [Table 5](#) for typical transient response values for several output voltage, input voltage and capacitance combinations. [Table 4](#) includes a preferred list of capacitors by vendor.

Table 3. Required Output Capacitance

V _{OUT} RANGE (V)		MINIMUM REQUIRED C _{OUT} (μF)
MIN	MAX	
0.6	< 0.8	400 μF ceramic
0.8	< 1.2	300 μF ceramic
1.2	< 3.0	200 μF ceramic
3.0	< 4.0	100 μF ceramic
4.0	5.5	47 μF ceramic

Table 4. Recommended Input/Output Capacitors⁽¹⁾

VENDOR	SERIES	PART NUMBER	CAPACITOR CHARACTERISTICS		
			WORKING VOLTAGE (V)	CAPACITANCE (μF)	ESR ⁽²⁾ (mΩ)
Murata	X5R	GRM32ER61E226K	16	22	2
TDK	X5R	C3225X5R0J476K	6.3	47	2
Murata	X5R	GRM32ER60J476M	6.3	47	2
Sanyo	POSCAP	16TQC68M	16	68	50
Kemet	T520	T520V107M010ASE025	10	100	25
Sanyo	POSCAP	6TPE100MI	6.3	100	25
Sanyo	POSCAP	2R5TPE220M7	2.5	220	7
Kemet	T530	T530D227M006ATE006	6.3	220	6
Kemet	T530	T530D337M006ATE010	6.3	330	10
Sanyo	POSCAP	2TPF330M6	2.0	330	6
Sanyo	POSCAP	6TPE330MFL	6.3	330	15

(1) Capacitor Supplier Verification

Please verify availability of capacitors identified in this table.

RoHS, Lead-free and Material Details

Please consult capacitor suppliers regarding material composition, RoHS status, lead-free status, and manufacturing process requirements.

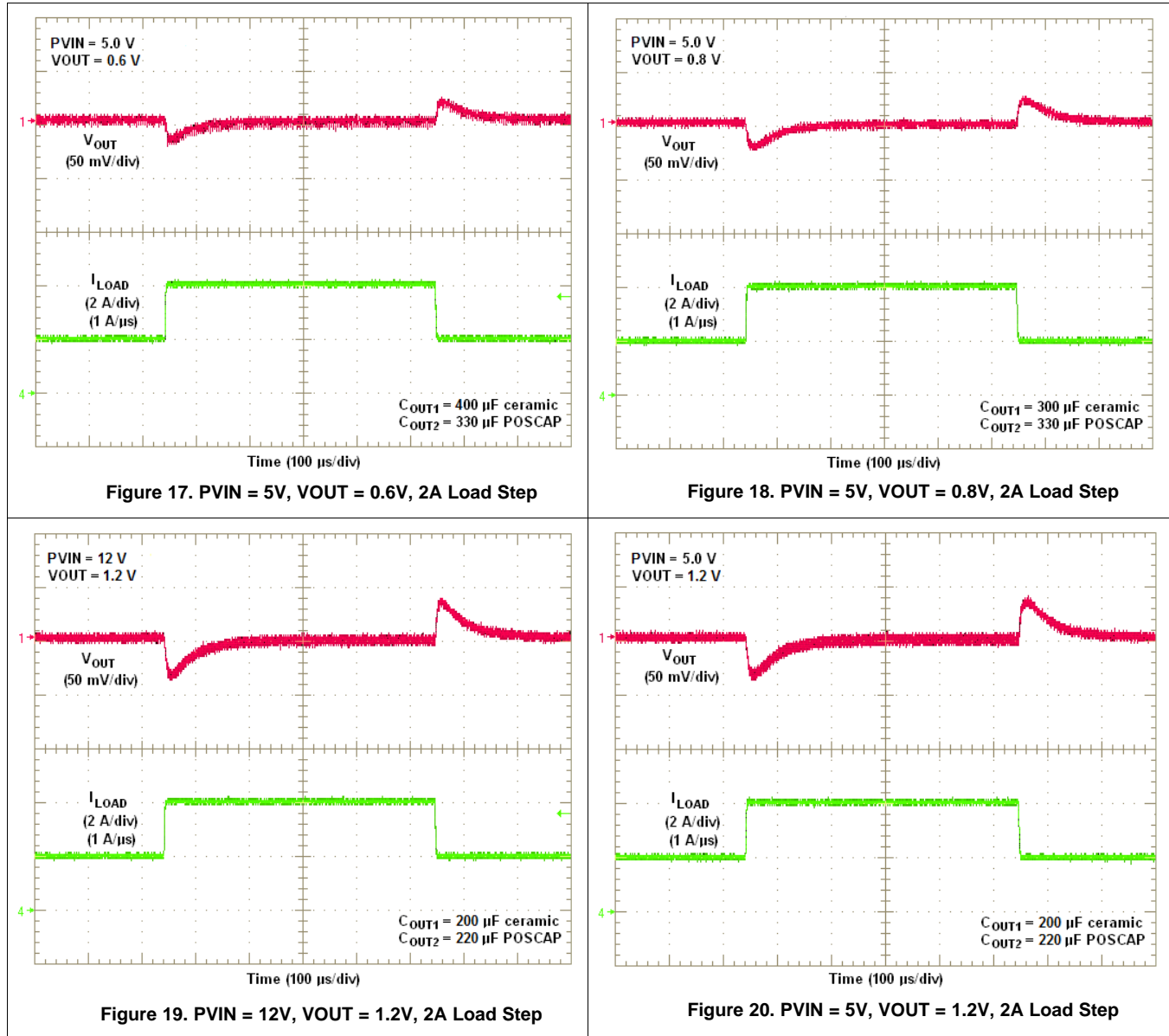
(2) Maximum ESR @ 100kHz, 25°C.

9.3 Transient Response

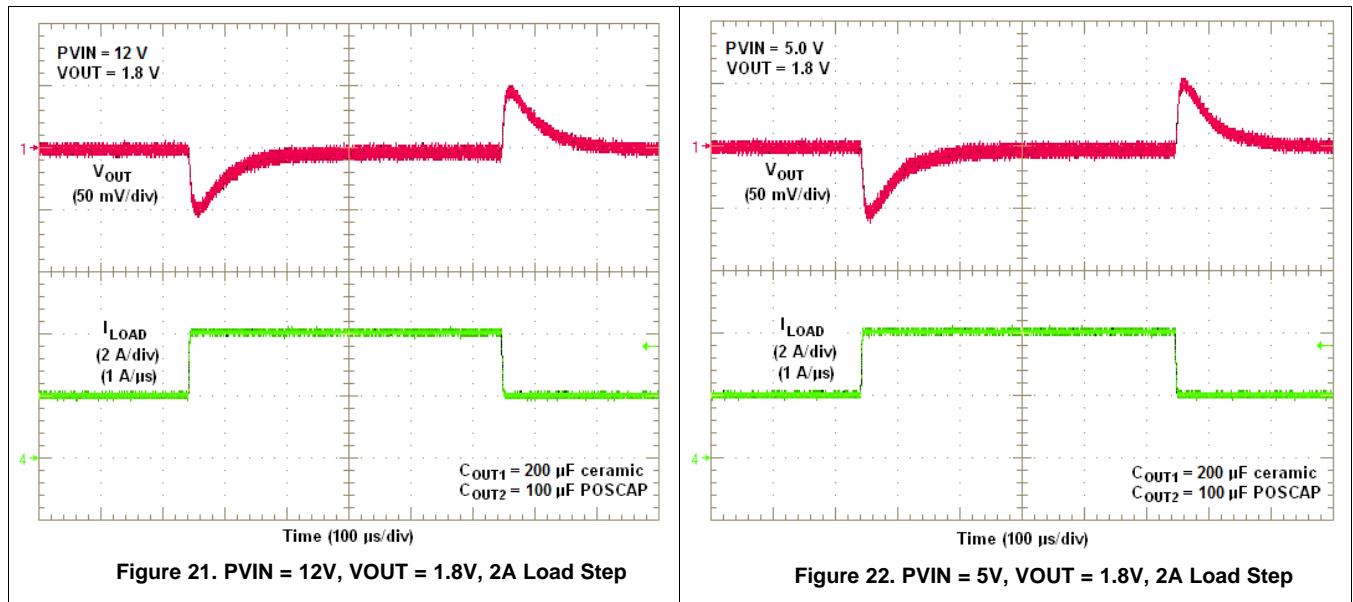
Table 5. Output Voltage Transient Response

C _{IN1} = 47 μF CERAMIC, C _{IN2} = 220 μF POLYMER-TANTALUM						
V _{OUT} (V)	V _{IN} (V)	C _{OUT1} Ceramic	C _{OUT2} BULK	VOLTAGE DEVIATION (mV)		RECOVERY TIME (μs)
				2 A LOAD STEP, (1 A/μs)	3 A LOAD STEP, (1 A/μs)	
0.6	5	400 μF	330 μF	20	30	120
0.8	5	300 μF	220 μF	25	35	140
		300 μF	330 μF	20	30	140
	12	300 μF	220 μF	30	35	140
		300 μF	330 μF	25	30	140
1.2	5	200 μF	100 μF	40	50	150
		200 μF	220 μF	35	45	150
	12	200 μF	100 μF	35	45	150
		200 μF	220 μF	30	40	150
1.8	5	200 μF	-	65	85	160
		200 μF	100 μF	55	96	160
	12	200 μF	-	55	80	160
		200 μF	100 μF	50	75	160
3.3	5	100 μF	100 μF	90	140	180
	12	100 μF	100 μF	85	125	180

9.4 Transient Waveforms



Transient Waveforms (continued)



9.5 Application Schematics

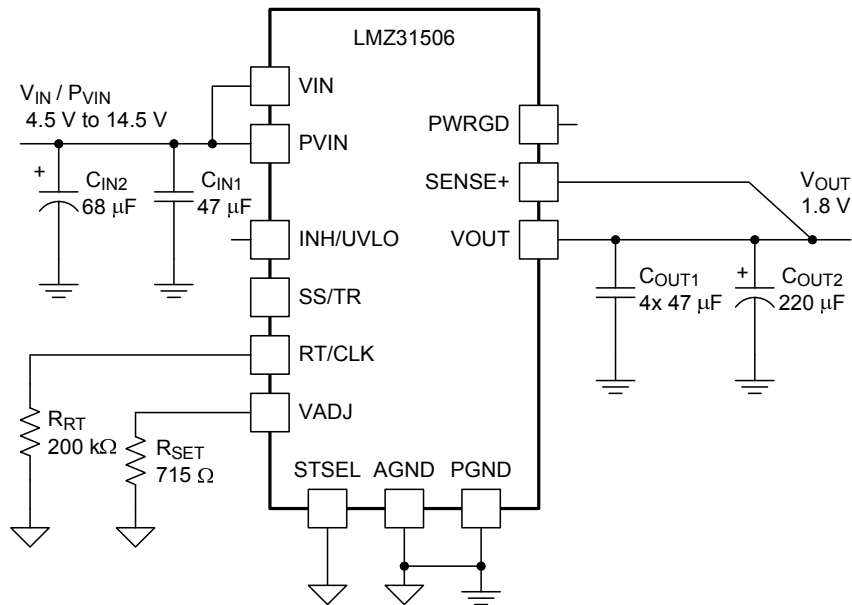


Figure 23. Typical Schematic
 $P_{VIN} = V_{IN} = 4.5V$ to $14.5V$, $V_{OUT} = 1.8V$

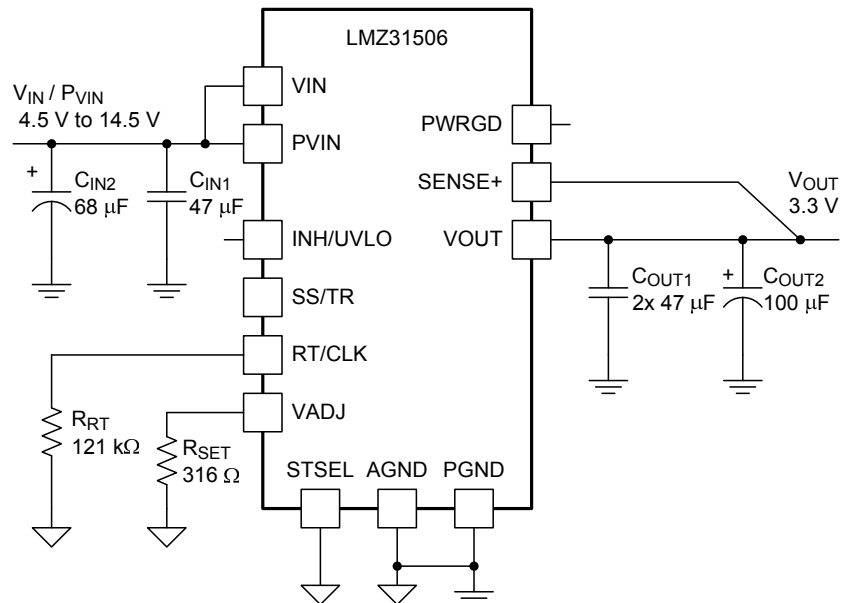
Application Schematics (continued)


Figure 24. Typical Schematic
 $P_{VIN} = V_{IN} = 4.5 \text{ V to } 14.5 \text{ V}$, $V_{OUT} = 3.3 \text{ V}$

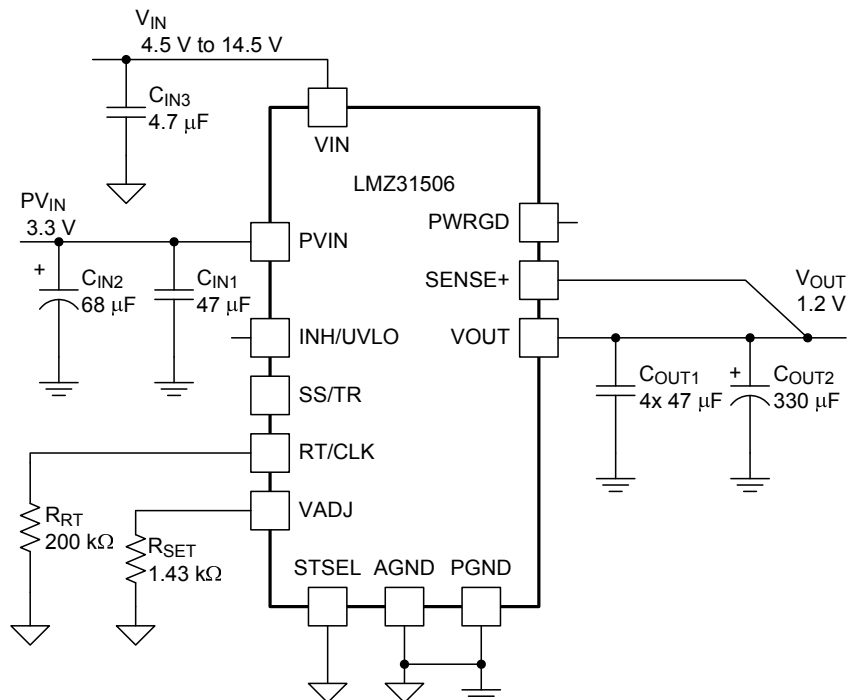


Figure 25. Typical Schematic
 $P_{VIN} = 3.3 \text{ V}$, $V_{IN} = 4.5 \text{ V to } 14.5 \text{ V}$, $V_{OUT} = 1.2 \text{ V}$

9.6 Custom Design With WEBENCH® Tools

[Click here](#) to create a custom design using the LMZ31506 device with the WEBENCH® Power Designer.

1. Start by entering the input voltage (V_{IN}), output voltage (V_{OUT}), and output current (I_{OUT}) requirements.
2. Optimize the design for key parameters such as efficiency, footprint, and cost using the optimizer dial.
3. Compare the generated design with other possible solutions from Texas Instruments.

The WEBENCH Power Designer provides a customized schematic along with a list of materials with real-time pricing and component availability.

In most cases, these actions are available:

- Run electrical simulations to see important waveforms and circuit performance
- Run thermal simulations to understand board thermal performance
- Export customized schematic and layout into popular CAD formats
- Print PDF reports for the design, and share the design with colleagues

Get more information about WEBENCH tools at www.ti.com/WEBENCH.

9.7 VIN and PVIN Input Voltage

The LMZ31506 allows for a variety of applications by using the VIN and PVIN pins together or separately. The VIN voltage supplies the internal control circuits of the device. The PVIN voltage provides the input voltage to the power converter system.

If tied together, the input voltage for the VIN pin and the PVIN pin can range from 4.5 V to 14.5 V. If using the VIN pin separately from the PVIN pin, the VIN pin must be between 4.5 V and 14.5 V, and the PVIN pin can range from as low as 1.6 V to 14.5 V. A voltage divider connected to the INH/UVLO pin can adjust the either input voltage UVLO appropriately. See the [Programmable Undervoltage Lockout \(UVLO\)](#) section of this datasheet for more information.

9.8 3.3-V Input Operation

Applications operating from 3.3 V must provide at least 4.5 V for VIN. See application note, [SLVA561](#) for help creating 5 V from 3.3 V using a small, simple charge pump device.

9.9 Power Good (PWRGD)

The PWRGD pin is an open drain output. Once the voltage on the SENSE+ pin is between 94% and 106% of the set voltage, the PWRGD pin pull-down is released and the pin floats. The recommended pull-up resistor value is between 10 k Ω and 100 k Ω to a voltage source that is 5.5 V or less. The PWRGD pin is in a defined state once VIN is greater than 1.0 V, but with reduced current sinking capability. The PWRGD pin achieves full current sinking capability once the VIN pin is above 4.5V. The PWRGD pin is pulled low when the voltage on SENSE+ is lower than 91% or greater than 109% of the nominal set voltage. Also, the PWRGD pin is pulled low if the input UVLO or thermal shutdown is asserted, the INH pin is pulled low, or the SS/TR pin is below 1.4 V.

9.10 Parallel Operation

Up to six LMZ31506 devices can be paralleled for increased output current. Multiple connections must be made between the paralleled devices and the component selection is slightly different than for a stand-alone LMZ31506 device. A typical LMZ31506 parallel schematic is shown in [Figure 26](#). Refer to application note, [SLVA574](#) for information and design help when paralleling multiple LMZ31506 devices.

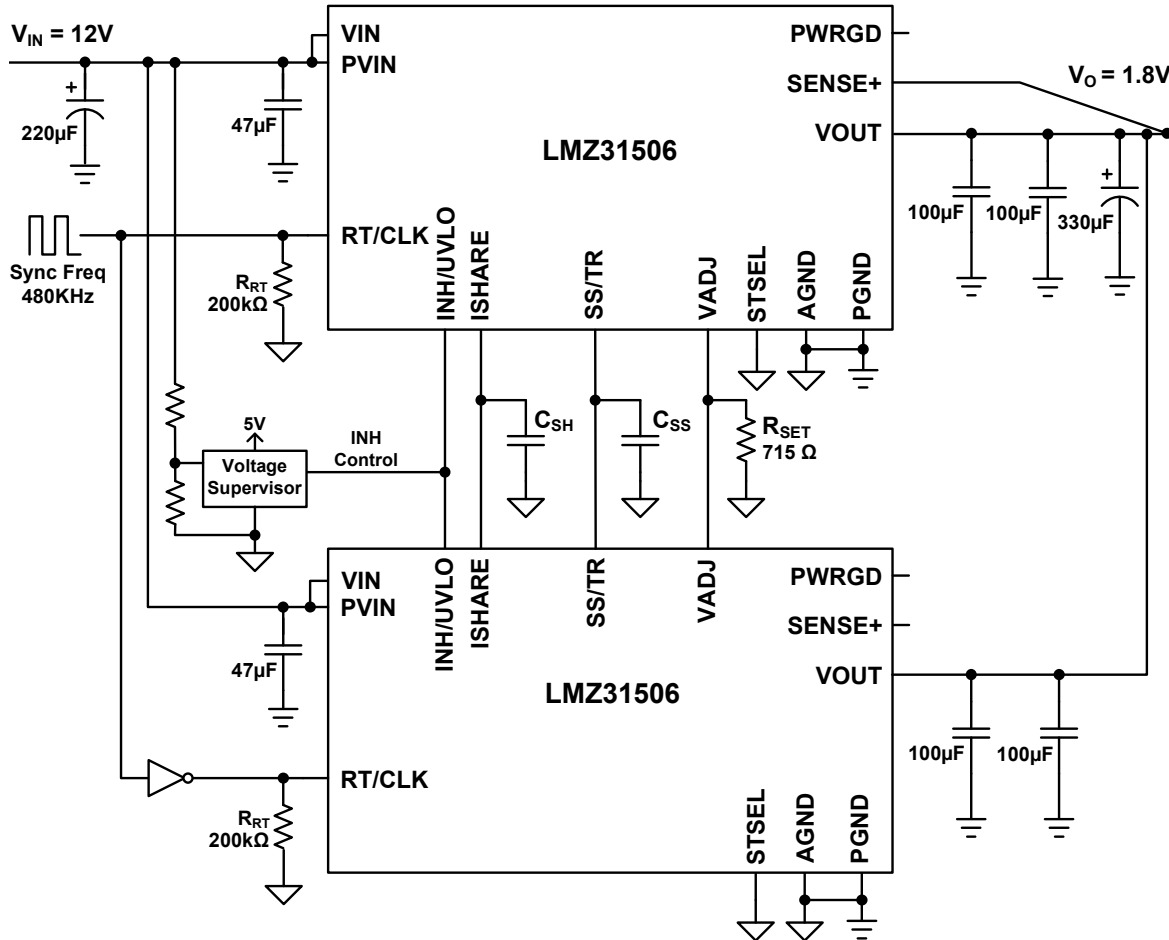
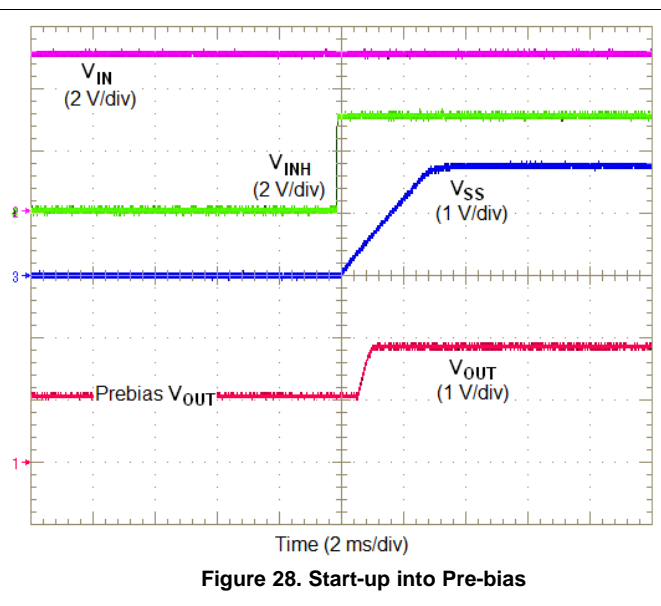
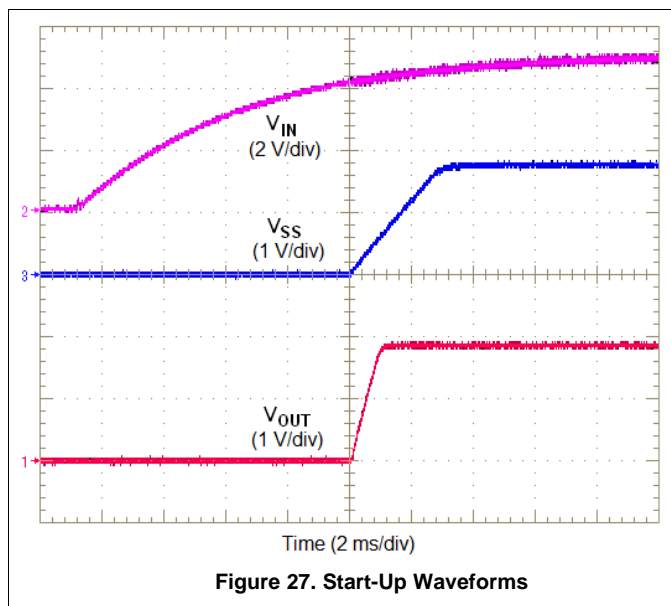


Figure 26. Typical LMZ31506 Parallel Schematic

9.11 Power-Up Characteristics

When configured as shown in the front page schematic, the LMZ31506 produces a regulated output voltage following the application of a valid input voltage. During the power-up, internal soft-start circuitry slows the rate that the output voltage rises, thereby limiting the amount of in-rush current that can be drawn from the input source. The soft-start circuitry introduces a short time delay from the point that a valid input voltage is recognized. [Figure 27](#) shows the start-up waveforms for a LMZ31506, operating from a 5-V input ($P_{VIN}=V_{IN}$) and with the output voltage adjusted to 1.8 V. [Figure 28](#) shows the start-up waveforms for a LMZ31506 starting up into a pre-biased output voltage. The waveforms were measured with a 3-A constant current load.



9.12 Pre-Biased Start-Up

The LMZ31506 has been designed to prevent discharging a pre-biased output. During monotonic pre-biased startup, the LMZ31506 does not allow current to sink until the SS/TR pin voltage is higher than 1.4 V.

9.13 Remote Sense

The SENSE+ pin must be connected to V_{OUT} at the load, or at the device pins.

Connecting the SENSE+ pin to V_{OUT} at the load improves the load regulation performance of the device by allowing it to compensate for any I-R voltage drop between its output pins and the load. An I-R drop is caused by the high output current flowing through the small amount of pin and trace resistance. This should be limited to a maximum of 300 mV.

NOTE

The remote sense feature is not designed to compensate for the forward drop of nonlinear or frequency dependent components that may be placed in series with the converter output. Examples include OR-ing diodes, filter inductors, ferrite beads, and fuses. When these components are enclosed by the SENSE+ connection, they are effectively placed inside the regulation control loop, which can adversely affect the stability of the regulator.

9.14 Thermal Shutdown

The internal thermal shutdown circuitry forces the device to stop switching if the junction temperature exceeds 175°C typically. The device reinitiates the power up sequence when the junction temperature drops below 165°C typically.

9.15 Output On/Off Inhibit (INH)

The INH pin provides electrical on/off control of the device. Once the INH pin voltage exceeds the threshold voltage, the device starts operation. If the INH pin voltage is pulled below the threshold voltage, the regulator stops switching and enters low quiescent current state.

The INH pin has an internal pull-up current source, allowing the user to float the INH pin for enabling the device. If an application requires controlling the INH pin, use an open drain/collector device, or a suitable logic gate to interface with the pin.

Figure 29 shows the typical application of the inhibit function. The Inhibit control has its own internal pull-up to VIN potential. An open-collector or open-drain device is recommended to control this input.

Turning Q1 on applies a low voltage to the inhibit control (INH) pin and disables the output of the supply, shown in Figure 30. If Q1 is turned off, the supply executes a soft-start power-up sequence, as shown in Figure 31. A regulated output voltage is produced within 3 ms. The waveforms were measured with a 3-A constant current load.

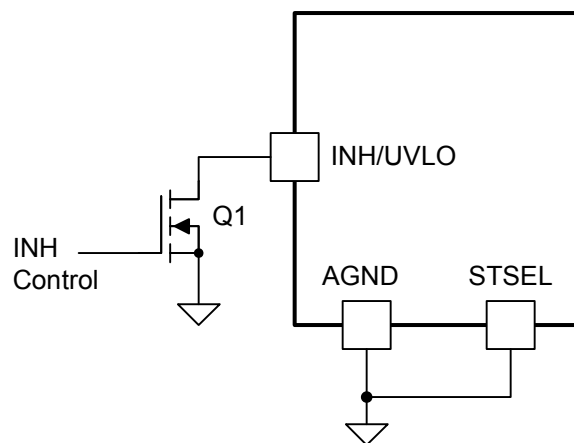


Figure 29. Typical Inhibit Control

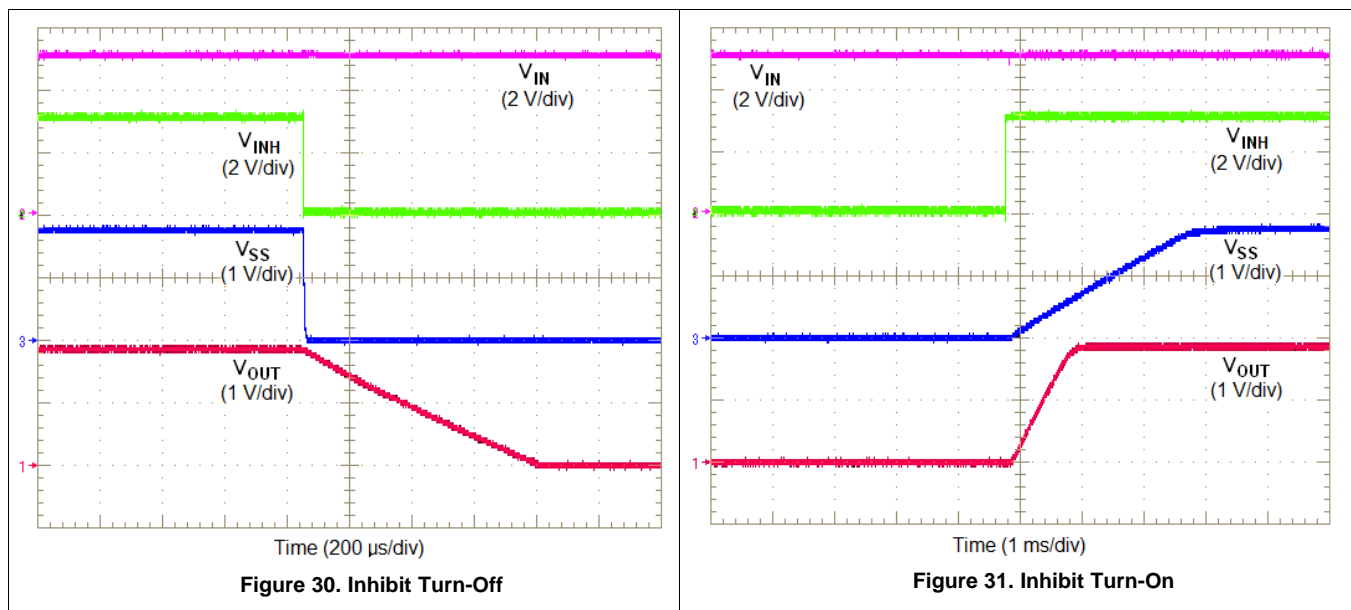


Figure 30. Inhibit Turn-Off

Figure 31. Inhibit Turn-On

9.16 Slow Start (SS/TR)

Connecting the STSEL pin to AGND and leaving SS/TR pin open enables the internal SS capacitor with a slow start interval of approximately 1.1 ms. Adding additional capacitance between the SS pin and AGND increases the slow start time. Table 6 shows an additional SS capacitor connected to the SS/TR pin and the STSEL pin connected to AGND. See Table 6 below for SS capacitor values and timing interval.

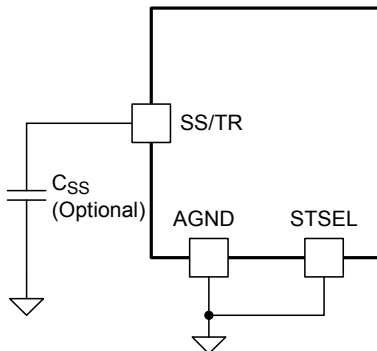


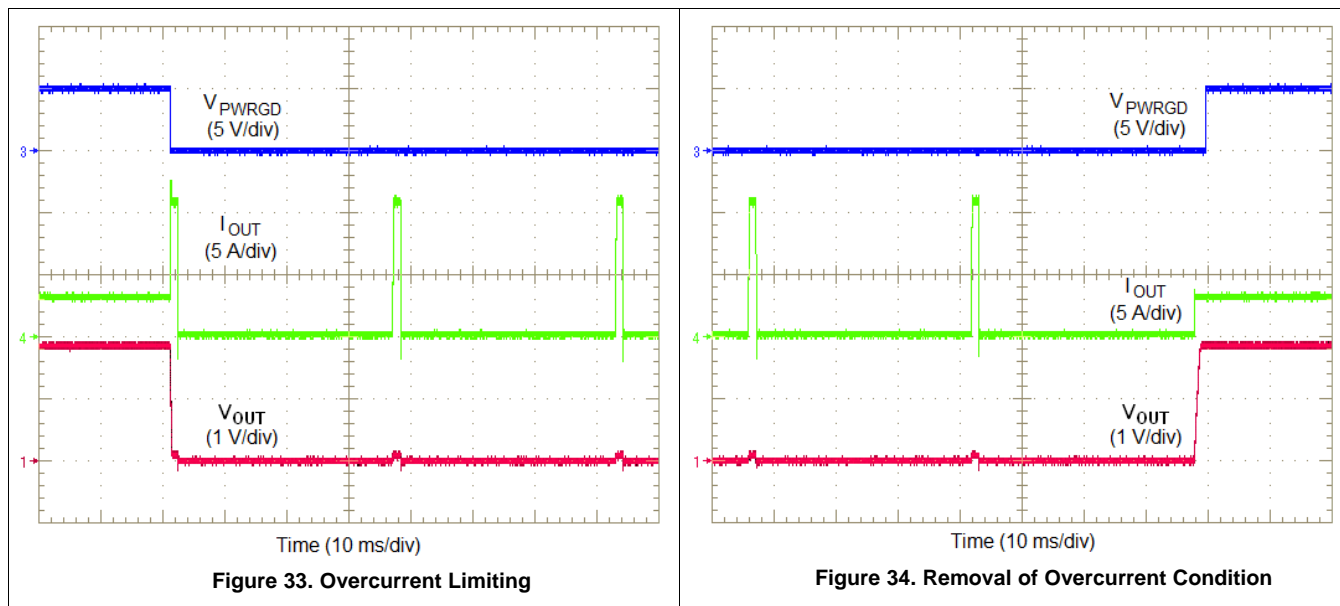
Figure 32. Slow-Start Capacitor (C_{SS}) and STSEL Connection

Table 6. Slow-Start Capacitor Values and Slow-Start Time

C _{SS} (pF)	open	2200	4700	10000	15000	22000	25000
SS Time (msec)	1.1	1.9	2.8	4.6	6.4	8.8	9.8

9.17 Overcurrent Protection

For protection against load faults, the LMZ31506 incorporates output overcurrent protection. Applying a load that exceeds the regulator's overcurrent threshold causes the regulated output to shut down. Following shutdown, the module periodically attempts to recover by initiating a soft-start power-up as shown in Figure 33. This is described as a hiccup mode of operation, whereby the module continues in a cycle of successive shutdown and power up until the load fault is removed. During this period, the average current flowing into the fault is significantly reduced. Once the fault is removed, the module automatically recovers and returns to normal operation as shown in Figure 34.



9.18 Synchronization (CLK)

An internal phase locked loop (PLL) has been implemented to allow synchronization between 250 kHz and 780 kHz, and to easily switch from RT mode to CLK mode. To implement the synchronization feature, connect a square wave clock signal to the RT/CLK pin with a duty cycle between 20% to 80%. The clock signal amplitude must transition lower than 0.8 V and higher than 2.0 V. The start of the switching cycle is synchronized to the falling edge of RT/CLK pin. In applications where both RT mode and CLK mode are needed, the device can be configured as shown in .

Before the external clock is present, the device works in RT mode and the switching frequency is set by RT resistor. When the external clock is present, the CLK mode overrides the RT mode. The first time the CLK pin is pulled above the RT/CLK high threshold (2.0 V), the device switches from RT mode to th CLK mode and the RT/CLK pin becomes high impedance as the PLL starts to lock onto the frequency of the external clock. It is not recommended to switch from CLK mode back to RT mode because the internal switching frequency drops to 100 kHz first before returning to the switching frequency set by the RT resistor (R_{RT}).

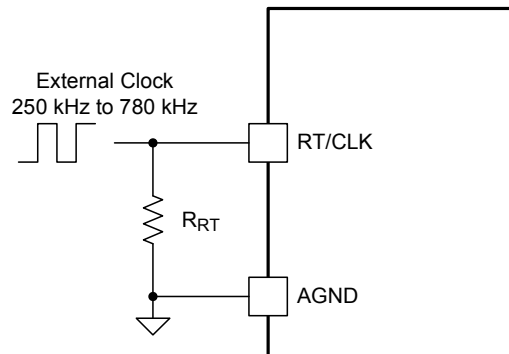


Figure 35. CLK/RT Configuration

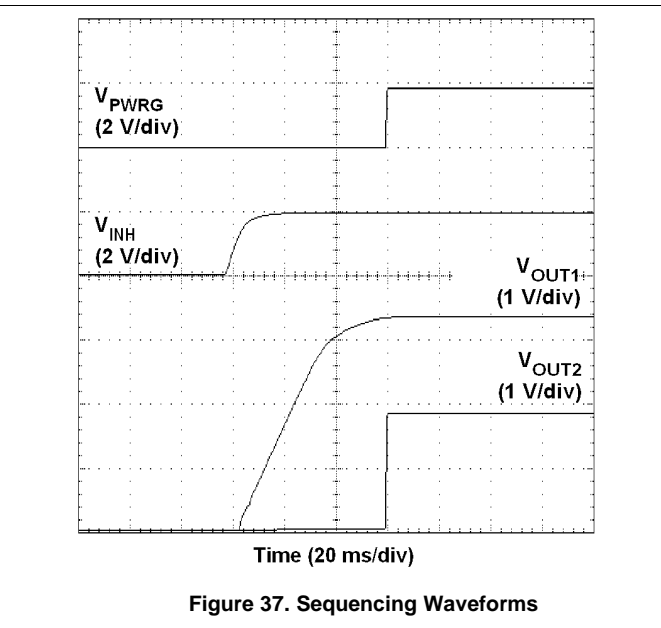
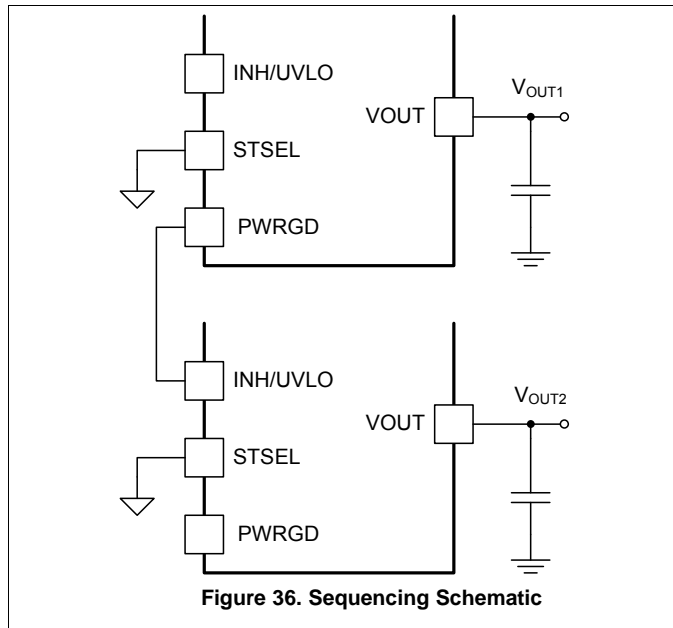
The synchronization frequency must be selected based on the output voltages of the devices being synchronized. [Table 7](#) shows the allowable frequencies for a given range of output voltages. For the most efficient solution, always synchronize to the lowest allowable frequency. For example, an application requires synchronizing three LMZ31506 devices with output voltages of 1.2 V, 1.8 V and 3.3 V, all powered from $PV_{IN} = 12$ V. [Table 7](#) shows that all three output voltages should be synchronized to 630 kHz.

Table 7. Synchronization Frequency vs Output Voltage

SYNCHRONIZATION FREQUENCY (kHz)	R_{RT} (k Ω)	$PV_{IN} = 12$ V		$PV_{IN} = 5$ V	
		V_{OUT} RANGE (V)		V_{OUT} RANGE (V)	
		MIN	MAX	MIN	MAX
250	open	0.6	1.0	0.6	1.3
280	1100	0.6	1.2	0.6	1.6
330	590	0.6	1.5	0.6	4.5
380	357	0.7	1.7	0.6	4.5
430	261	0.8	2.1	0.6	4.5
480	200	0.9	2.5	0.6	4.5
530	165	1.0	2.9	0.6	4.5
580	140	1.1	3.2	0.6	4.5
630	121	1.2	3.7	0.6	4.5
680	107	1.3	4.1	0.6	4.5
730	95.3	1.4	4.7	0.6	4.5
780	86.6	1.5	5.5	0.6	4.5

9.19 Sequencing (SS/TR)

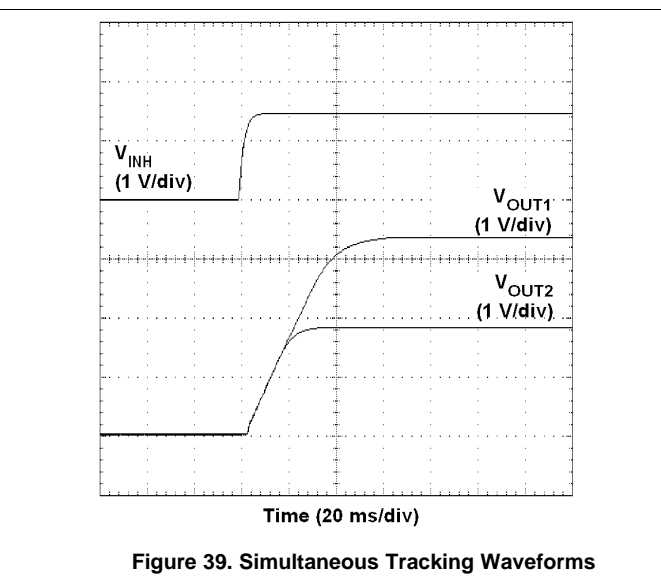
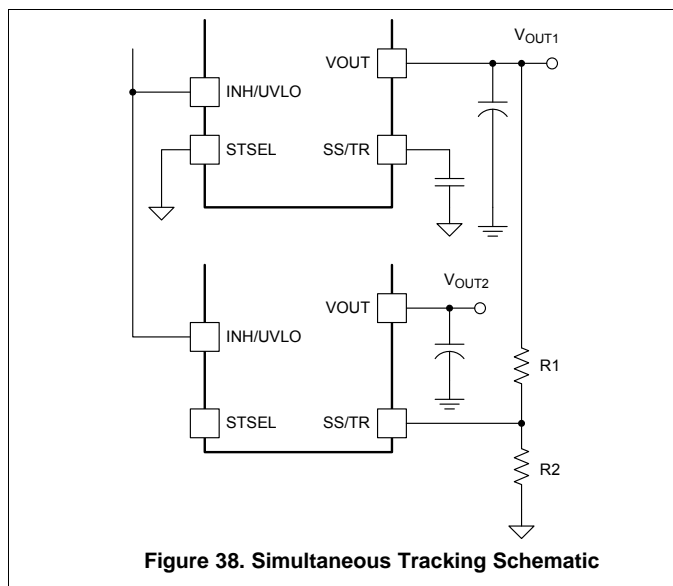
Many of the common power supply sequencing methods can be implemented using the SS/TR, INH and PWRGD pins. The sequential method is illustrated in Figure 36 using two LMZ31506 devices. The PWRGD pin of the first device is coupled to the INH pin of the second device which enables the second power supply once the primary supply reaches regulation. Figure 37 shows sequential turn-on waveforms of two LMZ31506 devices.



Simultaneous power supply sequencing can be implemented by connecting the resistor network of R1 and R2 shown in Figure 38 to the output of the power supply that needs to be tracked or to another voltage reference source. Figure 39 shows simultaneous turn-on waveforms of two LMZ31506 devices. Use Equation 2 and Equation 3 to calculate the values of R1 and R2.

$$R1 = \frac{(V_{OUT2} \times 12.6)}{0.6} \text{ (k}\Omega\text{)} \quad (2)$$

$$R2 = \frac{0.6 \times R1}{(V_{OUT2} - 0.6)} \text{ (k}\Omega\text{)} \quad (3)$$



9.20 Programmable Undervoltage Lockout (UVLO)

The LMZ31506 implements internal UVLO circuitry on the VIN pin. The device is disabled when the VIN pin voltage falls below the internal VIN UVLO threshold. The internal VIN UVLO rising threshold is 4.5 V(max) with a typical hysteresis of 150 mV.

If an application requires either a higher UVLO threshold on the VIN pin or a higher UVLO threshold for a combined VIN and PVIN, then the UVLO pin can be configured as shown in Figure 40 or Figure 41. Table 8 lists standard values for R_{UVLO1} and R_{UVLO2} to adjust the VIN UVLO voltage up.

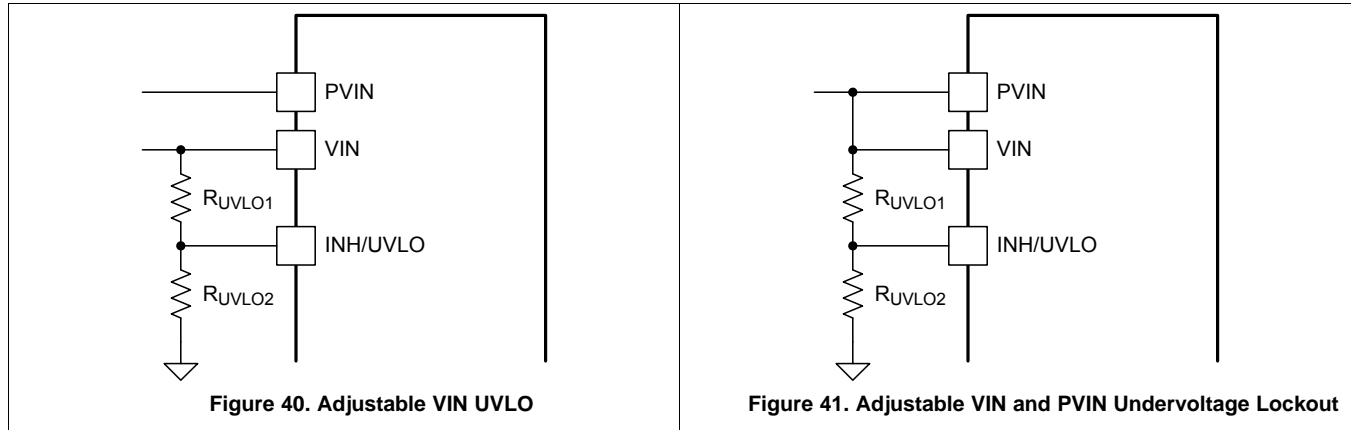


Table 8. Standard Resistor values for Adjusting VIN UVLO

VIN UVLO (V)	5.0	5.5	6.0	6.5	7.0	7.5	8.0	8.5	9.0	9.5	10.0
R_{UVLO1} (k Ω)	68.1	68.1	68.1	68.1	68.1	68.1	68.1	68.1	68.1	68.1	68.1
R_{UVLO2} (k Ω)	21.5	18.7	16.9	15.4	14.0	13.0	12.1	11.3	10.5	9.76	9.31
Hysteresis (mV)	400	415	430	450	465	480	500	515	530	550	565

For a split rail application, if a secondary UVLO on PVIN is required, VIN must be $\geq 4.5V$. Figure 42 shows the PVIN UVLO configuration. Use Table 9 to select R_{UVLO1} and R_{UVLO2} for PVIN. If PVIN UVLO is set for less than 3.0 V, a 5.1-V zener diode should be added to clamp the voltage on the UVLO pin below 6 V.

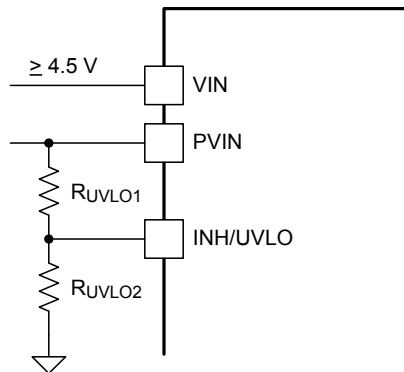


Figure 42. Adjustable PVIN Undervoltage Lockout, (VIN $\geq 4.5V$)

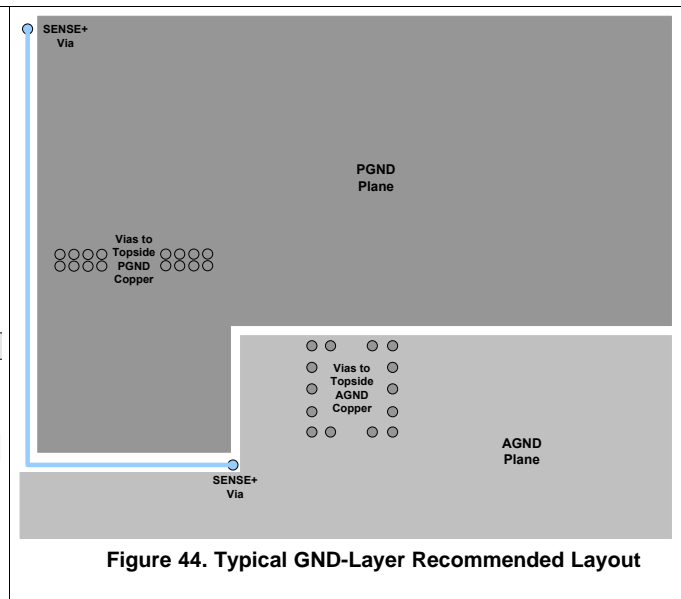
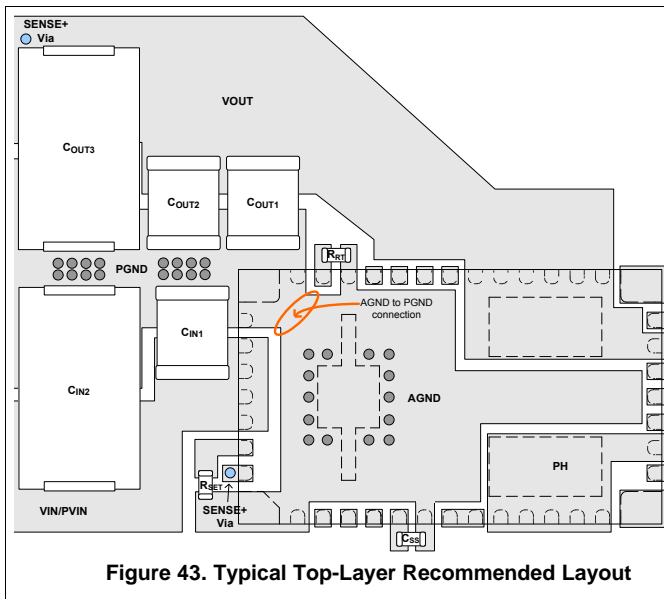
Table 9. Standard Resistor Values for Adjusting PVIN UVLO, (VIN $\geq 4.5V$)

PVIN UVLO (V)	2.0	2.5	3.0	3.5	4.0	4.5	
R_{UVLO1} (k Ω)	68.1	68.1	68.1	68.1	68.1	68.1	For higher PVIN UVLO voltages see Table UV for resistor values
R_{UVLO2} (k Ω)	95.3	60.4	44.2	34.8	28.7	24.3	
Hysteresis (mV)	300	315	335	350	365	385	

9.21 Layout Considerations

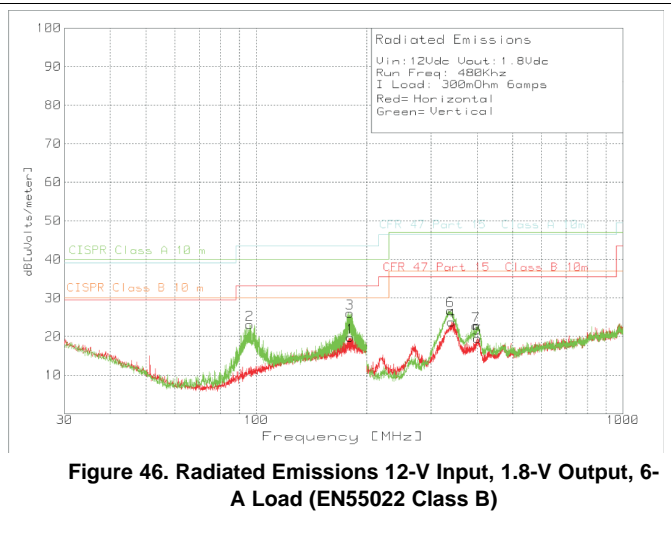
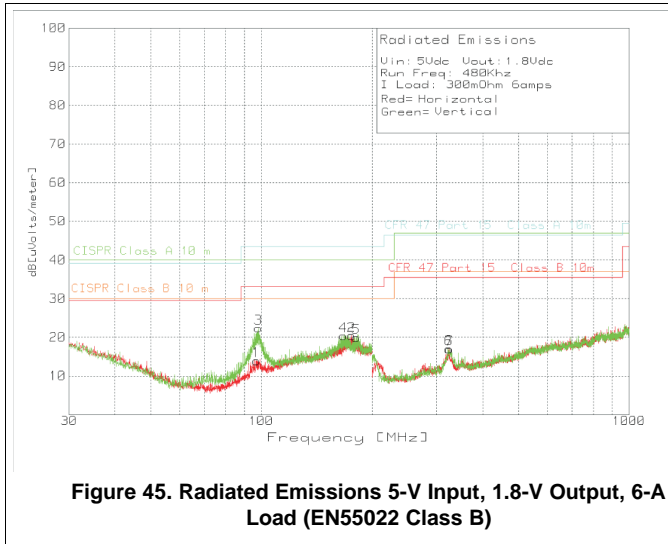
To achieve optimal electrical and thermal performance, an optimized PCB layout is required. [Figure 43](#) and [Figure 44](#) show two layers of a typical PCB layout. Some considerations for an optimized layout are:

- Use large copper areas for power planes (PVIN, VOUT, and PGND) to minimize conduction loss and thermal stress.
- Place ceramic input and output capacitors close to the device pins to minimize high frequency noise.
- Locate additional output capacitors between the ceramic capacitor and the load.
- Place a dedicated AGND copper area beneath the LMZ31506.
- Isolate the PH copper area from the VOUT copper area using the AGND copper area.
- Connect the AGND and PGND copper area at one point; see AGND to PGND connection point in [Figure 43](#).
- Place R_{SET} , R_{RT} , and C_{SS} as close as possible to their respective pins.
- Use multiple vias to connect the power planes to internal layers.



9.22 EMI

The LMZ31506 is compliant with EN55022 Class B radiated emissions. [Figure 46](#) and [Figure 45](#) show typical examples of radiated emissions plots for the LMZ31506 operating from 5V and 12V respectively. Both graphs include the plots of the antenna in the horizontal and vertical positions.



10 Revision History

NOTE: Page numbers for previous revisions may differ from page numbers in the current version.

Changes from Revision A (June 2017) to Revision B	Page
• 添加 LMZ31506 的 WEBENCH® 设计链接	1
• Increased the peak reflow temperature and maximum number of reflows to JEDEC specifications for improved manufacturability	2
• 添加器件支持部分	28
• 添加机械、封装和可订购信息部分	29

Changes from Original (July 2013) to Revision A	Page
• Added peak reflow and maximum number of reflows information	2

11 器件和文档支持

11.1 器件支持

11.1.1 开发支持

11.1.1.1 使用 WEBENCH® 工具创建定制设计

单击[此处](#)，使用 LMZ31506 器件并借助 WEBENCH® 电源设计器创建定制设计方案。

1. 首先键入输入电压 (V_{IN})、输出电压 (V_{OUT}) 和输出电流 (I_{OUT}) 要求。
2. 使用优化器拨盘优化关键参数设计，如效率、封装和成本。
3. 将生成的设计与德州仪器 (TI) 的其他解决方案进行比较。

WEBENCH 电源设计器可提供定制原理图以及罗列实时价格和组件供货情况的物料清单。

在多数情况下，可执行以下操作：

- 运行电气仿真，观察重要波形以及电路性能
- 运行热性能仿真，了解电路板热性能
- 将定制原理图和布局方案导出至常用 CAD 格式
- 打印设计方案的 PDF 报告并与同事共享

有关 WEBENCH 工具的详细信息，请访问 www.ti.com.cn/WEBENCH。

11.2 文档支持

11.2.1 相关文档

请参阅如下相关文档：

[BQFN 封装的焊接要求](#)

11.3 接收文档更新通知

要接收文档更新通知，请导航至 TI.com.cn 上的器件产品文件夹。单击右上角的[通知我](#)进行注册，即可每周接收产品信息更改摘要。有关更改的详细信息，请查看任何已修订文档中包含的修订历史记录。

11.4 社区资源

下列链接提供到 TI 社区资源的连接。链接的内容由各个分销商“按照原样”提供。这些内容并不构成 TI 技术规范，并且不一定反映 TI 的观点；请参阅 TI 的 [《使用条款》](#)。

TI E2E™ 在线社区 *TI 的工程师对工程师 (E2E) 社区*。此社区的创建目的在于促进工程师之间的协作。在 e2e.ti.com 中，您可以咨询问题、分享知识、拓展思路并与同行工程师一道帮助解决问题。

设计支持 *TI 参考设计支持* 可帮助您快速查找有帮助的 E2E 论坛、设计支持工具以及技术支持的联系信息。

11.5 商标

E2E is a trademark of Texas Instruments.

WEBENCH is a registered trademark of Texas Instruments.

All other trademarks are the property of their respective owners.

11.6 静电放电警告



ESD 可能会损坏该集成电路。德州仪器 (TI) 建议通过适当的预防措施处理所有集成电路。如果不遵守正确的处理措施和安装程序，可能会损坏集成电路。

ESD 的损坏小至导致微小的性能降级，大至整个器件故障。精密的集成电路可能更容易受到损坏，这是因为非常细微的参数更改都可能会导致器件与其发布的规格不相符。

11.7 术语表

[SLYZ022](#) — *TI 术语表*。

这份术语表列出并解释术语、缩写和定义。

12 机械、封装和可订购信息

以下页面包含机械、封装和可订购信息。这些信息是指定器件的最新可用数据。数据如有变更，恕不另行通知，且不会对此文档进行修订。如需获取此数据表的浏览器版本，请参阅左侧的导航栏。

PACKAGING INFORMATION

Orderable Device	Status (1)	Package Type	Package Drawing	Pins	Package Qty	Eco Plan (2)	Lead/Ball Finish (6)	MSL Peak Temp (3)	Op Temp (°C)	Device Marking (4/5)	Samples
LMZ31506RUQR	ACTIVE	B1QFN	RUQ	47	500	RoHS Exempt & Green	NIPDAU	Level-3-245C-168 HR	-40 to 85	LMZ31506	Samples
LMZ31506RUQT	ACTIVE	B1QFN	RUQ	47	250	RoHS Exempt & Green	NIPDAU	Level-3-245C-168 HR	-40 to 85	LMZ31506	Samples

(1) The marketing status values are defined as follows:

ACTIVE: Product device recommended for new designs.

LIFEBUY: TI has announced that the device will be discontinued, and a lifetime-buy period is in effect.

NRND: Not recommended for new designs. Device is in production to support existing customers, but TI does not recommend using this part in a new design.

PREVIEW: Device has been announced but is not in production. Samples may or may not be available.

OBSOLETE: TI has discontinued the production of the device.

(2) **RoHS:** TI defines "RoHS" to mean semiconductor products that are compliant with the current EU RoHS requirements for all 10 RoHS substances, including the requirement that RoHS substance do not exceed 0.1% by weight in homogeneous materials. Where designed to be soldered at high temperatures, "RoHS" products are suitable for use in specified lead-free processes. TI may reference these types of products as "Pb-Free".

RoHS Exempt: TI defines "RoHS Exempt" to mean products that contain lead but are compliant with EU RoHS pursuant to a specific EU RoHS exemption.

Green: TI defines "Green" to mean the content of Chlorine (Cl) and Bromine (Br) based flame retardants meet JS709B low halogen requirements of <=1000ppm threshold. Antimony trioxide based flame retardants must also meet the <=1000ppm threshold requirement.

(3) MSL, Peak Temp. - The Moisture Sensitivity Level rating according to the JEDEC industry standard classifications, and peak solder temperature.

(4) There may be additional marking, which relates to the logo, the lot trace code information, or the environmental category on the device.

(5) Multiple Device Markings will be inside parentheses. Only one Device Marking contained in parentheses and separated by a "~" will appear on a device. If a line is indented then it is a continuation of the previous line and the two combined represent the entire Device Marking for that device.

(6) Lead/Ball Finish - Orderable Devices may have multiple material finish options. Finish options are separated by a vertical ruled line. Lead/Ball Finish values may wrap to two lines if the finish value exceeds the maximum column width.

Important Information and Disclaimer:The information provided on this page represents TI's knowledge and belief as of the date that it is provided. TI bases its knowledge and belief on information provided by third parties, and makes no representation or warranty as to the accuracy of such information. Efforts are underway to better integrate information from third parties. TI has taken and continues to take reasonable steps to provide representative and accurate information but may not have conducted destructive testing or chemical analysis on incoming materials and chemicals. TI and TI suppliers consider certain information to be proprietary, and thus CAS numbers and other limited information may not be available for release.

In no event shall TI's liability arising out of such information exceed the total purchase price of the TI part(s) at issue in this document sold by TI to Customer on an annual basis.

TAPE AND REEL INFORMATION

QUADRANT ASSIGNMENTS FOR PIN 1 ORIENTATION IN TAPE


*All dimensions are nominal

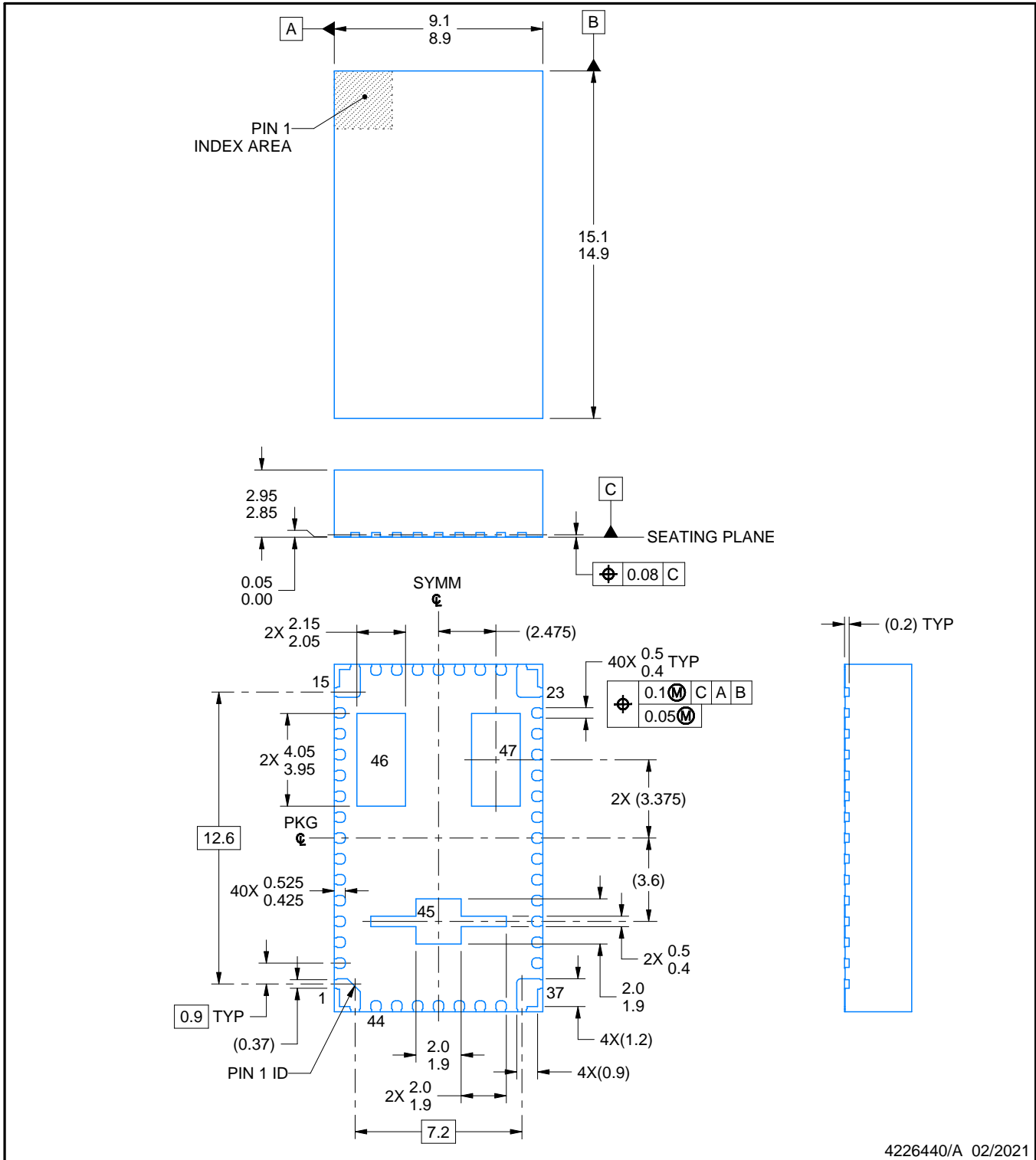
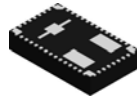
Device	Package Type	Package Drawing	Pins	SPQ	Reel Diameter (mm)	Reel Width W1 (mm)	A0 (mm)	B0 (mm)	K0 (mm)	P1 (mm)	W (mm)	Pin1 Quadrant
LMZ31506RUQR	B1QFN	RUQ	47	500	330.0	24.4	9.35	15.35	3.1	16.0	24.0	Q1
LMZ31506RUQT	B1QFN	RUQ	47	250	330.0	24.4	9.35	15.35	3.1	16.0	24.0	Q1

TAPE AND REEL BOX DIMENSIONS



*All dimensions are nominal

Device	Package Type	Package Drawing	Pins	SPQ	Length (mm)	Width (mm)	Height (mm)
LMZ31506RUQR	B1QFN	RUQ	47	500	383.0	353.0	58.0
LMZ31506RUQT	B1QFN	RUQ	47	250	383.0	353.0	58.0



4226440/A 02/2021

NOTES:

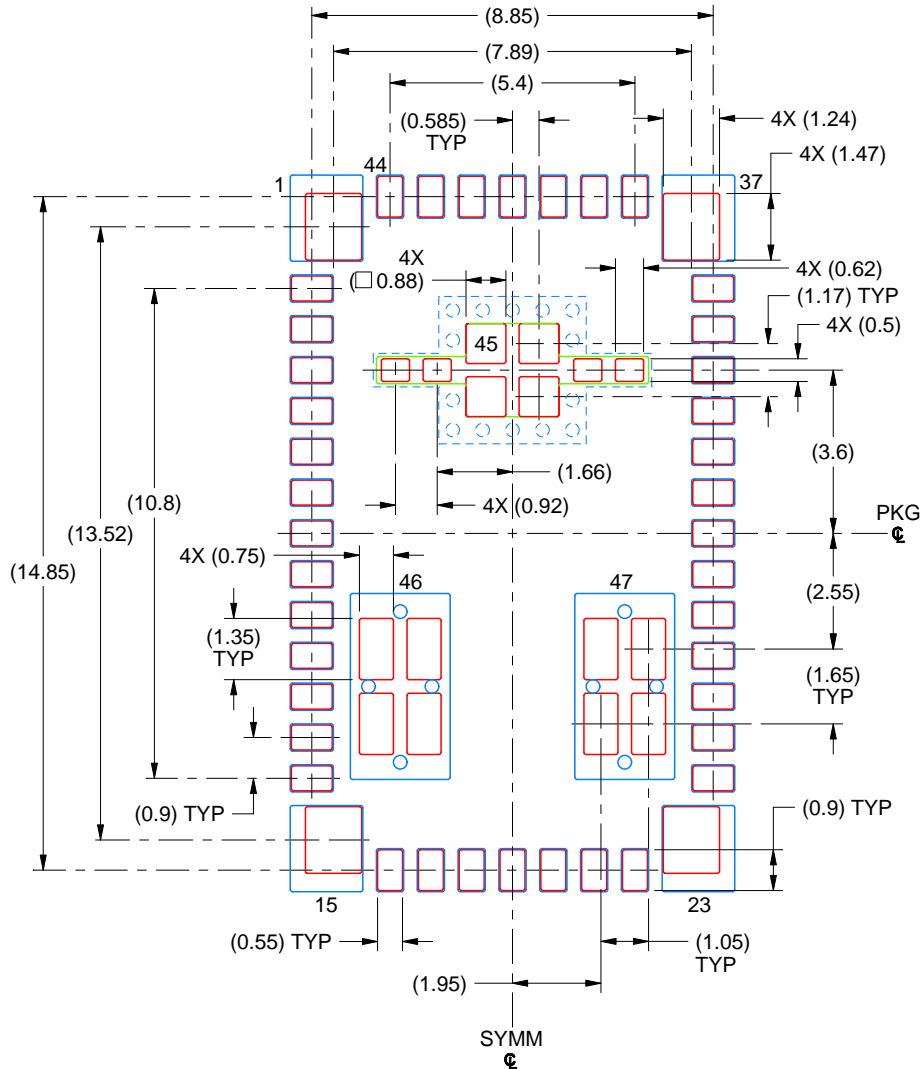
1. All linear dimensions are in millimeters. Any dimensions in parenthesis are for reference only. Dimensioning and tolerancing per ASME Y14.5M.
2. This drawing is subject to change without notice.
3. The package thermal pads must be soldered to the printed circuit board for optimal thermal and mechanical performance.

EXAMPLE STENCIL DESIGN

RUQ0047A

B1QFN - 2.95 mm max height

PLASTIC QUAD FLATPACK - NO LEAD



SOLDER PASTE EXAMPLE
 BASED ON 0.1 mm STENCIL THICKNESS

CORNER PINS 1, 15, 23 & 37:
 60% PRINTED SOLDER COVERAGE BY AREA UNDER PACKAGE

EXPOSED PAD 45:
 66% PRINTED SOLDER COVERAGE BY AREA UNDER PACKAGE

EXPOSED PAD 46 & 47:
 45% PRINTED SOLDER COVERAGE BY AREA UNDER PACKAGE
 SCALE:6X

4226440/A 02/2021

NOTES: (continued)

6. Laser cutting apertures with trapezoidal walls and rounded corners may offer better paste release. IPC-7525 may have alternate design recommendations.

重要声明和免责声明

TI 提供技术和可靠性数据（包括数据表）、设计资源（包括参考设计）、应用或其他设计建议、网络工具、安全信息和其他资源，不保证没有瑕疵且不做任何明示或暗示的担保，包括但不限于对适销性、某特定用途方面的适用性或不侵犯任何第三方知识产权的暗示担保。

这些资源可供使用 TI 产品进行设计的熟练开发人员使用。您将自行承担以下全部责任：(1) 针对您的应用选择合适的 TI 产品，(2) 设计、验证并测试您的应用，(3) 确保您的应用满足相应标准以及任何其他安全、安保或其他要求。这些资源如有变更，恕不另行通知。TI 授权您仅可将这些资源用于研发本资源所述的 TI 产品的应用。严禁对这些资源进行其他复制或展示。您无权使用任何其他 TI 知识产权或任何第三方知识产权。您应全额赔偿因在这些资源的使用中对 TI 及其代表造成的任何索赔、损害、成本、损失和债务，TI 对此概不负责。

TI 提供的产品受 TI 的销售条款 (<https://www.ti.com.cn/zh-cn/legal/termsofsale.html>) 或 [ti.com.cn](https://www.ti.com.cn) 上其他适用条款/TI 产品随附的其他适用条款的约束。TI 提供这些资源并不会扩展或以其他方式更改 TI 针对 TI 产品发布的适用的担保或担保免责声明。

邮寄地址：上海市浦东新区世纪大道 1568 号中建大厦 32 楼，邮政编码：200122
Copyright © 2021 德州仪器半导体技术（上海）有限公司