

具有 $\pm 15\text{kV}$ ESD 保护功能的 MAX3221 3V 至 5.5V RS-232 线路驱动器和接收器

1 特性

- 使用人体放电模型 (HBM) 时, RS-232 总线引脚 ESD 保护大于 $\pm 15\text{kV}$
- 符合或超出 TIA/EIA-232-F 和 ITU V.28 标准的要求
- 由 3V 至 5.5V V_{CC} 电源供电
- 运行速率高达 250kbps
- 一个驱动器和一个接收器
- 低待机电流: $1\ \mu\text{A}$ (典型值)
- 外部电容器: $4 \times 0.1\ \mu\text{F}$
- 接受 5V 逻辑输入及 3.3V 电源
- 备选高速引脚兼容器件 (1Mbps)
 - SNx5C3221
- 自动断电功能可自动禁用驱动器以节省能耗

2 应用

- 工业 PC
- 有线网络
- 数据中心和企业级计算
- 电池供电型系统
- PDA
- 笔记本电脑
- 便携式计算机
- 掌上电脑
- 手持设备

3 说明

MAX3221 器件包含一个线路驱动器、一个具有专用使用引脚的线路接收器和一个具有引脚对引脚 (串行端口连接引脚, 包括 GND) $\pm 15\text{kV}$ ESD 保护功能的双电荷泵电路。该器件符合 TIA/EIA-232-F 的要求并在异步通信控制器与串行端口连接器之间提供电气接口。电荷泵和四个小型外部电容器支持由 3V 至 5.5V 单电源供电。

这些器件以高达 250kbps 的数据信号传输速率和最大值为 $30\text{V}/\mu\text{s}$ 的驱动器输出压摆率运行。

串行端口处于非活动状态时, 可提供灵活的电源管理控制选项。当 $\overline{\text{FORCEON}}$ 为低电平且 $\overline{\text{FORCEOFF}}$ 为高电平时, 自动断电功能启用。在这种运行模式下, 如果器件在接收器输入端未感应到有效的

RS-232 信号, 则会禁用驱动器输出, 且电源电流将降低至 $1\ \mu\text{A}$ 。INVALID 输出会通知用户接收器输入端是否存在 RS-232 信号。

器件信息

器件型号	封装 ⁽¹⁾	封装尺寸 (标称值)
MAX3221	SSOP (DB) (32)	6.20mm × 5.30mm
	TSSOP (PW) (32)	5.00mm × 4.40mm

(1) 如需了解所有可用封装, 请参阅数据表末尾的可订购产品附录。

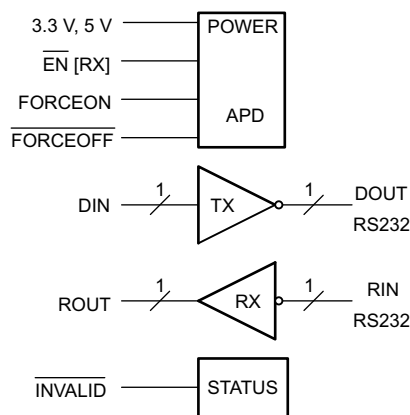

简化图



Table of Contents

1 特性	1	8 Detailed Description	11
2 应用	1	8.1 Overview.....	11
3 说明	1	8.2 Functional Block Diagram.....	11
4 Revision History	2	8.3 Feature Description.....	11
5 Pin Configuration and Functions	3	8.4 Device Functional Modes.....	12
6 Specifications	4	9 Application and Implementation	13
6.1 Absolute Maximum Ratings.....	4	9.1 Application Information.....	13
6.2 ESD Ratings.....	4	9.2 Typical Application.....	13
6.3 Recommended Operating Conditions.....	4	10 Power Supply Recommendations	14
6.4 Thermal Information.....	5	11 Layout	15
6.5 Electrical Characteristics - Power.....	5	11.1 Layout Guidelines.....	15
6.6 Electrical Characteristics - Driver.....	5	11.2 Layout Example.....	15
6.7 Electrical Characteristics - Receiver.....	6	12 Device and Documentation Support	16
6.8 Electrical Characteristics - Status.....	6	12.1 支持资源.....	16
6.9 Switching Characteristics - Driver.....	6	12.2 Trademarks.....	16
6.10 Switching Characteristics - Receiver.....	7	12.3 静电放电警告.....	16
6.11 Switching Characteristics - Status.....	7	12.4 术语表.....	16
6.12 Typical Characteristics.....	7	13 Mechanical, Packaging, and Orderable Information	16
7 Parameter Measurement Information	8		

4 Revision History

注：以前版本的页码可能与当前版本的页码不同

Changes from Revision O (June 2015) to Revision P (July 2021) Page

- 更改了 *应用* 列表.....1
- Changed the values in the *Thermal Information* table for DB and PW packages.....5

Changes from Revision N (January 2014) to Revision O (June 2015) Page

- 添加了 *引脚配置和功能* 部分、*ESD* 等级表、*特性说明* 部分、*器件功能模式*、*应用和实施* 部分、*电源相关建议* 部分、*布局* 部分、*器件和文档支持* 部分以及 *机械、封装和可订购信息* 部分.....1

Changes from Revision M (March 2004) to Revision N (January 2013) Page

- 将文档更新为新的 TI 数据表格式 - 无规格变化.....1
- 删除了 *订购信息* 表.....1

5 Pin Configuration and Functions



图 5-1. DB or PW Package, 16-Pin SSOP or TSSOP, Top View

表 5-1. Pin Functions

PIN		I/O	DESCRIPTION
NAME	NO.		
C1+	2	—	Positive terminals of the voltage-doubler charge-pump capacitors
C2+	5		
C1 -	4	—	Negative terminals of the voltage-doubler charge-pump capacitors
C2 -	6		
DIN	11	I	Driver input
DOUT	13	O	RS-232 driver output
EN	1	I	Low input enables receiver ROUT output. High input sets ROUT to high impedance.
FORCEOFF	16	I	Automatic power-down control input
FORCEON	12	I	Automatic power-down control input
GND	14	—	Ground
INVALID	10	O	Invalid output pin. Output low when all RIN inputs are unpowered.
RIN	8	I	RS-232 receiver input
ROUT	9	O	Receiver output
V _{CC}	15	—	3-V to 5.5-V supply voltage
V+	3	O	5.5-V supply generated by the charge pump
V-	7	O	- 5.5-V supply generated by the charge pump

6 Specifications

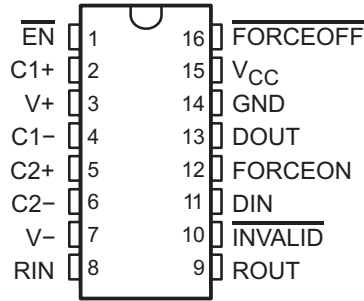
6.1 Absolute Maximum Ratings

over operating free-air temperature range (unless otherwise noted)⁽¹⁾

			MIN	MAX	UNIT
V _{CC} to GND			- 0.3	6	V
V+ to GND			- 0.3	7	
V- to GND			0.3	- 7	
V+ + V- ⁽²⁾				13	
V _I	Input voltage	DIN, EN, FORCEOFF, and FORCEON to GND	- 0.3	6	V
		RIN to GND		±25	
V _O	Output voltage	DOUT to GND		±13.2	V
		ROUT to GND	- 0.3	V _{CC} + 0.3	
T _J	Junction temperature ⁽³⁾			150	°C
T _{stg}	Storage temperature range		- 65	150	

- (1) Operation outside the *Absolute Maximum Ratings* may cause permanent device damage. *Absolute Maximum Ratings* do not imply functional operation of the device at these or any other conditions beyond those listed under *Recommended Operating Conditions*. If used outside the *Recommended Operating Conditions* but within the *Absolute Maximum Ratings*, the device may not be fully functional, and this may affect device reliability, functionality, performance, and shorten the device lifetime.
- (2) V+ and V- can have maximum magnitudes of 7 V, but their absolute difference cannot exceed 13 V.
- (3) Maximum power dissipation is a function of T_{J(max)}, R_{θJA}, and T_A. The maximum allowable power dissipation at any allowable ambient temperature is P_D = (T_{J(max)} - T_A) / R_{θJA}. Operating at the absolute maximum T_J of 150°C can affect reliability.

6.2 ESD Ratings

			VALUE	UNIT	
V _(ESD)	Electrostatic discharge	Human body model (HBM), per ANSI/ESDA/JEDEC JS-001 ⁽¹⁾	All pins except 8, 13	±3000	V
			Pins 8, 13	±15,000	
		Charged-device model (CDM), per JEDEC specification JESD22-C101 ⁽²⁾	±1500		

- (1) JEDEC document JEP155 states that 500-V HBM allows safe manufacturing with a standard ESD control process.
- (2) JEDEC document JEP157 states that 250-V CDM allows safe manufacturing with a standard ESD control process.

6.3 Recommended Operating Conditions

(see [图 9-1](#))⁽¹⁾

			MIN	NOM	MAX	UNIT
Supply voltage		V _{CC} = 3.3 V	3	3.3	3.6	V
		V _{CC} = 5 V	4.5	5	5.5	
V _{IH}	Driver high-level input voltage	DIN, FORCEOFF, FORCEON, EN	V _{CC} = 3.3 V	2		V
			V _{CC} = 5 V	2.4		
V _{IL}	Driver low-level input voltage	DIN, FORCEOFF, FORCEON, EN			0.8	V
V _I	Driver input voltage	DIN, FORCEOFF, FORCEON, EN	0		5.5	V
	Receiver input voltage		- 25		25	
T _A	Operating free-air temperature	MAX3221C	0		70	°C
		MAX3221I	- 40		85	

- (1) Test conditions are C1 - C4 = 0.1 μF at V_{CC} = 3.3 V ± 0.3 V; C1 = 0.047 μF, C2 - C4 = 0.33 μF at V_{CC} = 5 V ± 0.5 V.

6.4 Thermal Information

THERMAL METRIC ⁽¹⁾		MAX3221		UNIT
		DB (SSOP)	PW (TSSOP)	
		16 PINS	16 PINS	
$R_{\theta JA}$	Junction-to-ambient thermal resistance	105.8	110.9	°C/W
$R_{\theta JC(top)}$	Junction-to-case (top) thermal resistance	51.9	41.7	°C/W
$R_{\theta JB}$	Junction-to-board thermal resistance	57.6	57.2	°C/W
ψ_{JT}	Junction-to-top characterization parameter	14.1	4.2	°C/W
ψ_{JB}	Junction-to-board characterization parameter	56.8	56.6	°C/W

(1) For more information about traditional and new thermal metrics, see the *Semiconductor and IC Package Thermal Metrics* application report, [SPRA953](#).

6.5 Electrical Characteristics - Power

over recommended ranges of supply voltage and operating free-air temperature (unless otherwise noted)⁽²⁾

PARAMETER		TEST CONDITIONS		MIN	TYP ⁽¹⁾	MAX	UNIT
I_I	Input leakage current	FORCEOFF, FORCEON, EN		±0.01		±1	µA
I_{CC}	Supply current	Automatic power-down disabled	No load, FORCEOFF and FORCEON at V_{CC}		0.3	1	mA
		Powered off	No load, $V_{CC} = 3.3\text{ V to }5\text{ V}$		1	10	µA
		Automatic power-down enabled	No load, FORCEOFF at V_{CC} , FORCEON at GND, All RIN are open or grounded		1	10	

(1) All typical values are at $V_{CC} = 3.3\text{ V}$ or $V_{CC} = 5\text{ V}$, and $T_A = 25^\circ\text{C}$.

(2) Test conditions are $C1 - C4 = 0.1\ \mu\text{F}$ at $V_{CC} = 3.3\text{ V} \pm 0.3\text{ V}$; $C1 = 0.047\ \mu\text{F}$, $C2 - C4 = 0.33\ \mu\text{F}$ at $V_{CC} = 5\text{ V} \pm 0.5\text{ V}$.

6.6 Electrical Characteristics - Driver

over recommended ranges of supply voltage and operating free-air temperature (unless otherwise noted)⁽³⁾

PARAMETER		TEST CONDITIONS		MIN	TYP ⁽¹⁾	MAX	UNIT
V_{OH}	High-level output voltage	D_{OUT} at $R_L = 3\text{ k}\Omega$ to GND, $D_{IN} = \text{GND}$		5	5.4		V
V_{OL}	Low-level output voltage	D_{OUT} at $R_L = 3\text{ k}\Omega$ to GND, $D_{IN} = V_{CC}$		-5	-5.4		V
I_{IH}	High-level input current	$V_I = V_{CC}$			±0.01	±1	µA
I_{IL}	Low-level input current	V_I at GND			±0.01	±1	µA
I_{OS}	Short-circuit output current ⁽²⁾	$V_{CC} = 3.6\text{ V}$	$V_O = 0\text{ V}$		±35	±60	mA
		$V_{CC} = 5.5\text{ V}$	$V_O = 0\text{ V}$		±35	±60	
r_O	Output resistance	V_{CC} , $V+$, and $V- = 0\text{ V}$	$V_O = \pm 2\text{ V}$	300	10M		Ω
I_{off}	Output leakage current	FORCEOFF = GND	$V_O = \pm 12\text{ V}$, $V_{CC} = 3\text{ V to }3.6\text{ V}$			±25	µA
			$V_O = \pm 12\text{ V}$, $V_{CC} = 4.5\text{ V to }5.5\text{ V}$			±25	

(1) All typical values are at $V_{CC} = 3.3\text{ V}$ or $V_{CC} = 5\text{ V}$, and $T_A = 25^\circ\text{C}$.

(2) Short-circuit durations should be controlled to prevent exceeding the device absolute power dissipation ratings, and not more than one output should be shorted at a time.

(3) Test conditions are $C1 - C4 = 0.1\ \mu\text{F}$ at $V_{CC} = 3.3\text{ V} \pm 0.3\text{ V}$; $C1 = 0.047\ \mu\text{F}$, $C2 - C4 = 0.33\ \mu\text{F}$ at $V_{CC} = 5\text{ V} \pm 0.5$

6.7 Electrical Characteristics – Receiver

over recommended ranges of supply voltage and operating free-air temperature (unless otherwise noted)⁽²⁾

PARAMETER		TEST CONDITIONS	MIN	TYP ⁽¹⁾	MAX	UNIT
V _{OH}	High-level output voltage	I _{OH} = -1 mA	V _{CC} - 0.6	V _{CC} - 0.1		V
V _{OL}	Low-level output voltage	I _{OL} = 1.6 mA			0.4	V
V _{IT+}	Positive-going input threshold voltage	V _{CC} = 3.3 V		1.5	2.4	V
		V _{CC} = 5 V		1.8	2.4	
V _{IT-}	Negative-going input threshold voltage	V _{CC} = 3.3 V	0.6	1.1		V
		V _{CC} = 5 V	0.8	1.4		
V _{hys}	Input hysteresis (V _{IT+} - V _{IT-})			0.5		V
I _{off}	Output leakage current	FORCEOFF = 0 V		±0.05	±10	μA
r _i	Input resistance	V _i = ±3 V to ±25 V	3	5	7	kΩ

(1) All typical values are at V_{CC} = 3.3 V or V_{CC} = 5 V, and T_A = 25°C.

(2) Test conditions are C1 - C4 = 0.1 μF at V_{CC} = 3.3 V ± 0.3 V; C1 = 0.047 μF, C2 - C4 = 0.33 μF at V_{CC} = 5 V ± 0.5 V.

6.8 Electrical Characteristics – Status

over recommended ranges of supply voltage and operating free-air temperature (unless otherwise noted)⁽²⁾

PARAMETER		TEST CONDITIONS	MIN	TYP ⁽¹⁾	MAX	UNIT
V _{T+(valid)}	Receiver input threshold for INVALID high-level output voltage	FORCEON = GND, FORCEOFF = V _{CC}			2.7	V
V _{T-(valid)}	Receiver input threshold for INVALID high-level output voltage	FORCEON = GND, FORCEOFF = V _{CC}	-2.7			V
V _{T(invalid)}	Receiver input threshold for INVALID low-level output voltage	FORCEON = GND, FORCEOFF = V _{CC}	-0.3		0.3	V
V _{OH}	INVALID high-level output voltage	I _{OH} = -1 mA, FORCEON = GND, FORCEOFF = V _{CC}	V _{CC} - 0.6			V
V _{OL}	INVALID low-level output voltage	I _{OH} = -1 mA, FORCEON = GND, FORCEOFF = V _{CC}			0.4	V

(1) All typical values are at V_{CC} = 3.3 V or V_{CC} = 5 V, and T_A = 25°C.

(2) Test conditions are C1 - C4 = 0.1 μF at V_{CC} = 3.3 V ± 0.3 V; C1 = 0.047 μF, C2 - C4 = 0.33 μF at V_{CC} = 5 V ± 0.5 V.

6.9 Switching Characteristics – Driver

over recommended ranges of supply voltage and operating free-air temperature (unless otherwise noted)⁽³⁾

PARAMETER		TEST CONDITIONS	MIN	TYP ⁽¹⁾	MAX	UNIT
	Maximum data rate	C _L = 1000 pF, R _L = 3 kΩ, see Fig 7-1	150	250		kbps
t _{sk(p)}	Pulse skew ⁽²⁾	C _L = 150 to 2500 pF, R _L = 3 kΩ to 7 kΩ, see Fig 7-2		100		ns
SR(tr)	Slew rate, transition region (see Fig 7-1)	V _{CC} = 3.3 V, R _L = 3 kΩ to 7 kΩ	C _L = 150 to 1000 pF	6	30	V/μs
			C _L = 150 to 2500 pF	4	30	

(1) All typical values are at V_{CC} = 3.3 V or V_{CC} = 5 V, and T_A = 25°C.

(2) Pulse skew is defined as |t_{PLH} - t_{PHL}| of each channel of the same device.

(3) Test conditions are C1 - C4 = 0.1 μF at V_{CC} = 3.3 V ± 0.3 V; C1 = 0.047 μF, C2 - C4 = 0.33 μF at V_{CC} = 5 V ± 0.5 V.

6.10 Switching Characteristics - Receiver

over recommended ranges of supply voltage and operating free-air temperature (unless otherwise noted)⁽³⁾

PARAMETER		TEST CONDITIONS	MIN	TYP ⁽¹⁾	MAX	UNIT
t_{PLH}	Propagation delay time, low- to high-level output	$C_L = 150 \text{ pF}$, see 图 7-3		150		ns
t_{PHL}	Propagation delay time, high- to low-level output	$C_L = 150 \text{ pF}$, see 图 7-3		150		ns
t_{en}	Output enable time	$C_L = 150 \text{ pF}$, $R_L = 3 \text{ k}\Omega$, see 图 7-4		200		ns
t_{dis}	Output disable time	$C_L = 150 \text{ pF}$, $R_L = 3 \text{ k}\Omega$, see 图 7-4		200		ns
$t_{sk(p)}$	Pulse skew ⁽²⁾	See 图 7-3		50		ns

(1) All typical values are at $V_{CC} = 3.3 \text{ V}$ or $V_{CC} = 5 \text{ V}$, and $T_A = 25^\circ\text{C}$.

(2) Pulse skew is defined as $|t_{PLH} - t_{PHL}|$ of each channel of the same device.

(3) Test conditions are $C1 - C4 = 0.1 \text{ }\mu\text{F}$ at $V_{CC} = 3.3 \text{ V} \pm 0.3 \text{ V}$; $C1 = 0.047 \text{ }\mu\text{F}$, $C2 - C4 = 0.33 \text{ }\mu\text{F}$ at $V_{CC} = 5 \text{ V} \pm 0.5 \text{ V}$.

6.11 Switching Characteristics - Status

over recommended ranges of supply voltage and operating free-air temperature (unless otherwise noted)⁽²⁾

PARAMETER		MIN	TYP ⁽¹⁾	MAX	UNIT
t_{valid}	Propagation delay time, low- to high-level output		1		μs
$t_{invalid}$	Propagation delay time, high- to low-level output		30		μs
t_{en}	Supply enable time		100		μs

(1) All typical values are at $V_{CC} = 3.3 \text{ V}$ or $V_{CC} = 5 \text{ V}$, and $T_A = 25^\circ\text{C}$.

(2) Test conditions are $C1 - C4 = 0.1 \text{ }\mu\text{F}$ at $V_{CC} = 3.3 \text{ V} \pm 0.3 \text{ V}$; $C1 = 0.047 \text{ }\mu\text{F}$, $C2 - C4 = 0.33 \text{ }\mu\text{F}$ at $V_{CC} = 5 \text{ V} \pm 0.5 \text{ V}$.

6.12 Typical Characteristics

$V_{CC} = 3.3 \text{ V}$



图 6-1. DOUT V_{OH} vs Load Current



图 6-2. DOUT V_{OL} vs Load Current

7 Parameter Measurement Information

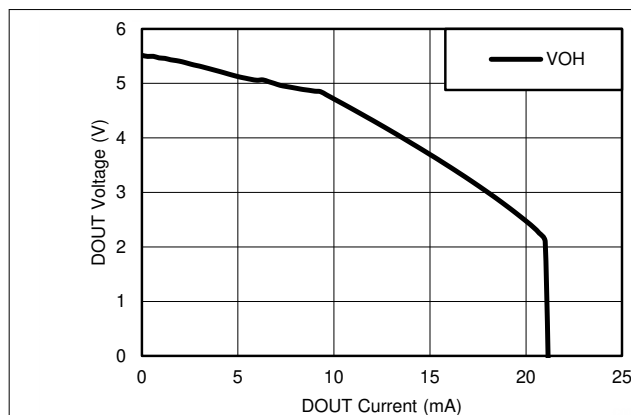

- A. C_L includes probe and jig capacitance.
- B. The pulse generator has the following characteristics: PRR = 250 kbps, $Z_O = 50\ \Omega$, 50% duty cycle, $t_r \leq 10\text{ ns}$, $t_f \leq 10\text{ ns}$.

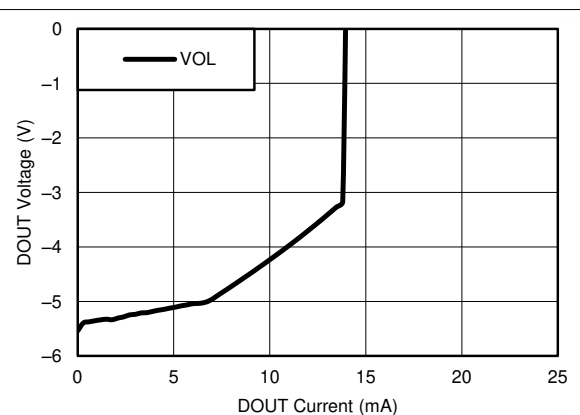
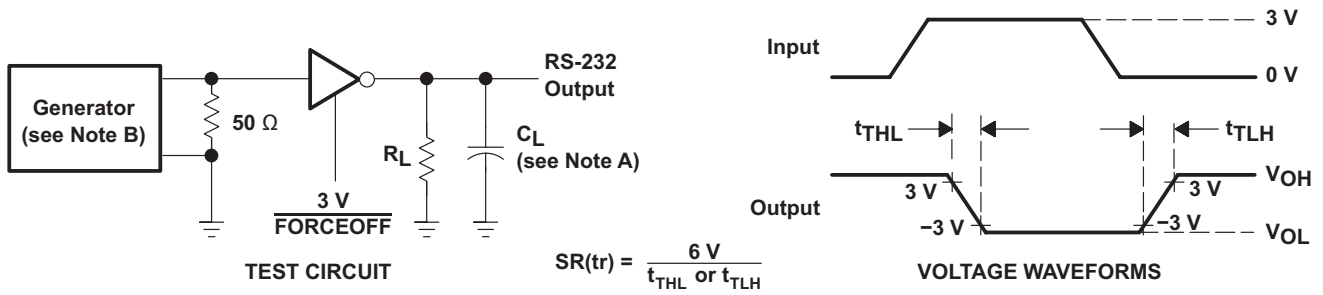
图 7-1. Driver Slew Rate

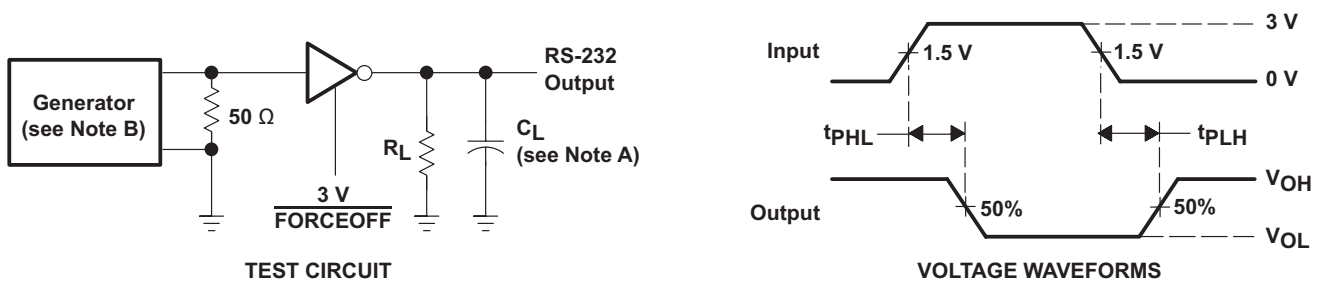

- A. C_L includes probe and jig capacitance.
- B. The pulse generator has the following characteristics: PRR = 250 kbps, $Z_O = 50\ \Omega$, 50% duty cycle, $t_r \leq 10\text{ ns}$, $t_f \leq 10\text{ ns}$.

图 7-2. Driver Pulse Skew

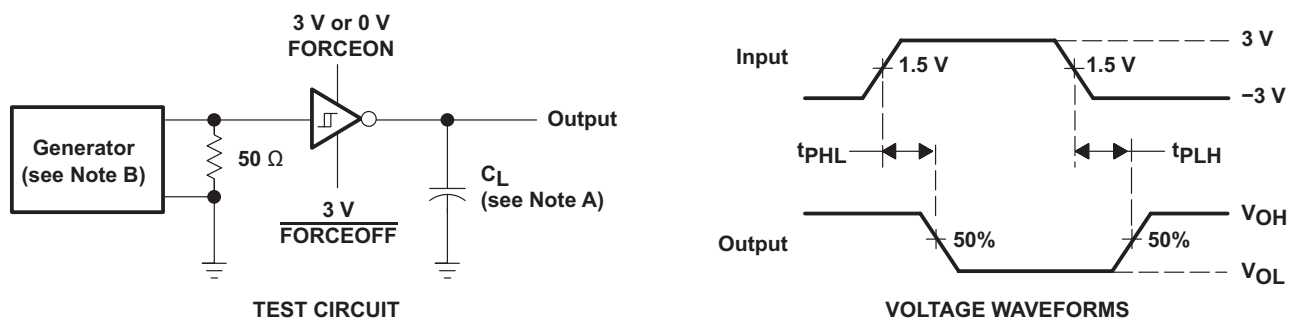

- A. C_L includes probe and jig capacitance.
- B. The pulse generator has the following characteristics: $Z_O = 50\ \Omega$, 50% duty cycle, $t_r \leq 10\text{ ns}$, $t_f \leq 10\text{ ns}$.

图 7-3. Receiver Propagation Delay Times

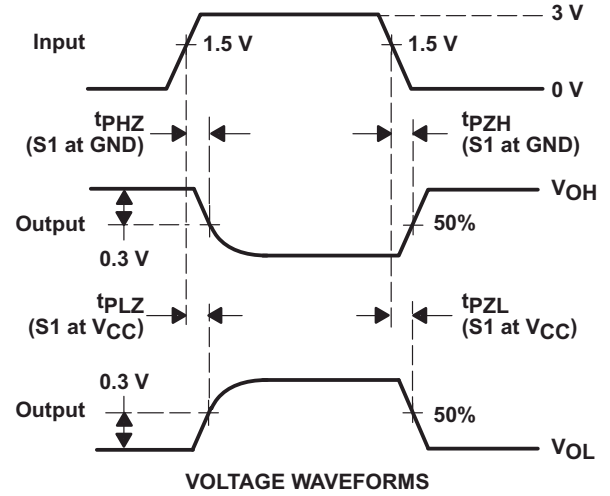
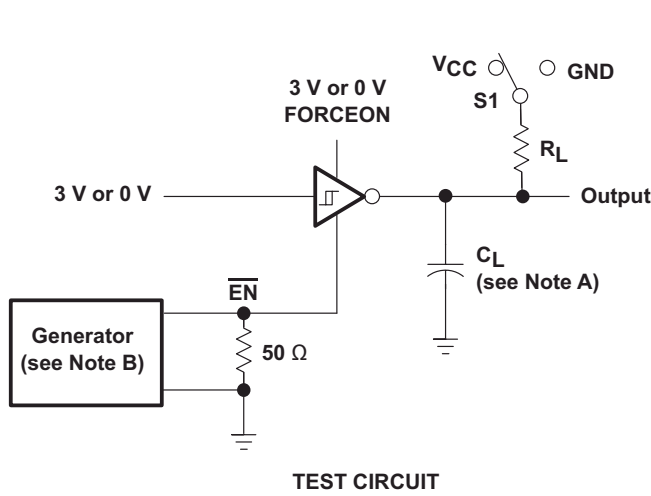

- A. C_L includes probe and jig capacitance.
- B. The pulse generator has the following characteristics: $Z_O = 50 \Omega$, 50% duty cycle, $t_r \leq 10 \text{ ns}$, $t_f \leq 10 \text{ ns}$.
- C. t_{PLZ} and t_{PHZ} are the same as t_{dis} .
- D. t_{PZL} and t_{PZH} are the same as t_{en} .

图 7-4. Receiver Enable and Disable Times

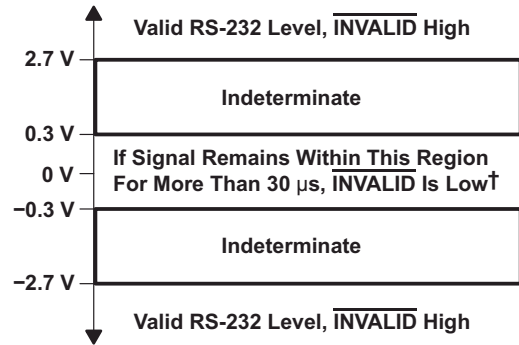
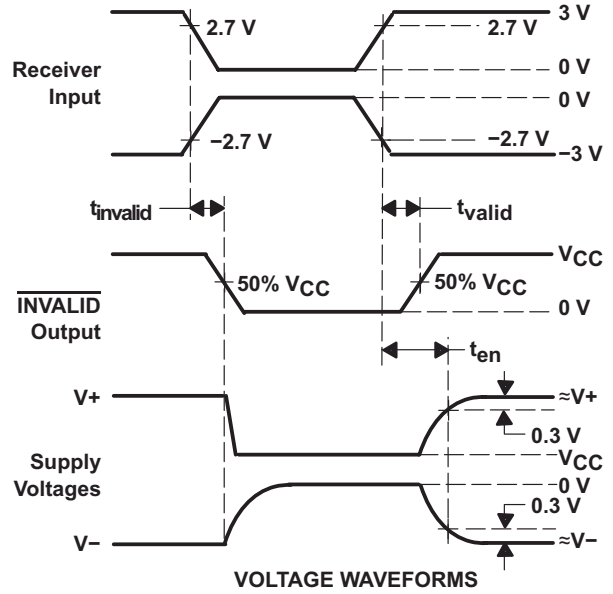
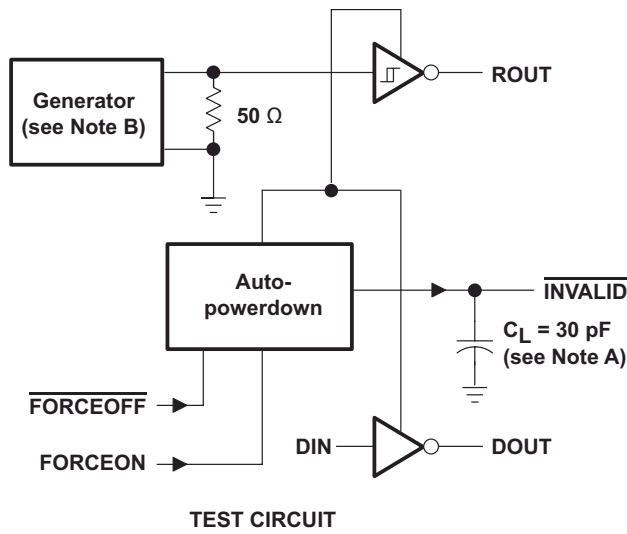

† Auto-powerdown disables drivers and reduces supply current to 1 μA.

图 7-5. INVALID Propagation Delay Times and Driver Enabling Time

8 Detailed Description

8.1 Overview

The MAX3221 device is a one-driver and one-receiver RS-232 interface device. All RS-232 inputs and outputs are protected to ± 15 kV using the Human Body Model. The charge pump requires only four small 0.1- μ F capacitors for operation from a 3.3-V supply. The MAX3221 is capable of running at data rates up to 250 kbps, while maintaining RS-232-compliant output levels.

Automatic power-down can be disabled when $\overline{\text{FORCEON}}$ and $\overline{\text{FORCEOFF}}$ are high. With automatic power-down plus enabled, the device activates automatically when a valid signal is applied to any receiver input. The device can automatically power down the driver to save power when the RIN input is unpowered.

$\overline{\text{INVALID}}$ is high (valid data) if receiver input voltage is greater than 2.7 V or less than -2.7 V, or has been between -0.3 V and 0.3 V for less than 30 μ s. $\overline{\text{INVALID}}$ is low (invalid data) if receiver input voltages are between -0.3 V and 0.3 V for more than 30 μ s. Refer to [Figure 7-5](#) for receiver input levels.

8.2 Functional Block Diagram

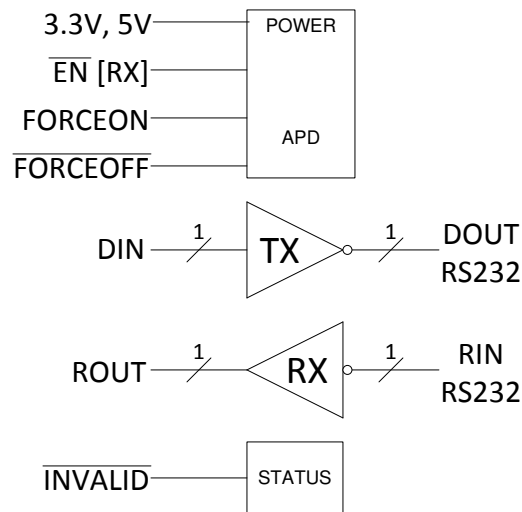

8.3 Feature Description

8.3.1 Power

The power block increases, inverts, and regulates voltage at V+ and V- pins using a charge pump that requires four external capacitors. Auto-power-down feature for driver is controlled by $\overline{\text{FORCEON}}$ and $\overline{\text{FORCEOFF}}$ inputs. Receiver is controlled by $\overline{\text{EN}}$ input. See [Table 8-1](#) and [Table 8-2](#).

When MAX3221 is unpowered, it can be safely connected to an active remote RS232 device.

8.3.2 RS232 Driver

One driver interfaces standard logic level to RS232 levels. DIN input must be valid high or low.

8.3.3 RS232 Receiver

One receiver interfaces RS232 levels to standard logic levels. An open input will result in a high output on ROUT. RIN input includes an internal standard RS232 load. A logic high input on the $\overline{\text{EN}}$ pin will shutdown the receiver output.

8.3.4 RS232 Status

The $\overline{\text{INVALID}}$ output goes low when RIN input is unpowered for more than 30 μ s. The $\overline{\text{INVALID}}$ output goes high when receiver has a valid input. The $\overline{\text{INVALID}}$ output is active when V_{CC} is powered regardless of $\overline{\text{FORCEON}}$ and $\overline{\text{FORCEOFF}}$ inputs (see [Table 8-3](#)).

8.4 Device Functional Modes

表 8-1, 表 8-2, 和 表 8-3 show the behavior of the driver, receiver, and INVALID(activelow) features under all possible relevant combinations of inputs.

表 8-1. Driver⁽¹⁾

INPUTS				OUTPUT		DRIVER STATUS
DIN	FORCEON	FORCEOFF	VALID RIN RS-232 LEVEL	DOUT		
X	X	L	X	Z		Powered off
L	H	H	X	H		Normal operation with automatic power down disabled
H	H	H	X	L		
L	L	H	Yes	H		Normal operation with automatic power down enabled
H	L	H	Yes	L		
L	L	H	No	Z		Powered off by automatic power down feature
H	L	H	No	Z		

(1) H = high level, L = low level, X = irrelevant, Z = high impedance, Yes = $|RIN| > 2.7 V$, No = $|RIN| < 0.3 V$

表 8-2. Receiver⁽¹⁾

INPUTS			OUTPUT		RECEIVER STATUS
RIN	EN	VALID RIN RS-232 LEVEL	ROUT		
X	H	X	Z		Output off
L	L	X	H		Normal operation
H	L	X	L		
Open	L	No	H		

(1) H = high level, L = low level, X = irrelevant, Z = high impedance (off), Open = input disconnected or connected driver off

表 8-3. INVALID⁽¹⁾

INPUTS				OUTPUT
RIN	FORCEON	FORCEOFF	EN	INVALID
L	X	X	X	H
H	X	X	X	H
Open	X	X	X	L

(1) H = high level, L = low level, X = irrelevant, Z = high impedance (off), Open = input disconnected or connected driver off



图 8-1. Logic Diagram

9 Application and Implementation

Note

以下应用部分中的信息不属于 TI 器件规格的范围，TI 不担保其准确性和完整性。TI 的客户应负责确定器件是否适用于其应用。客户应验证并测试其设计，以确保系统功能。

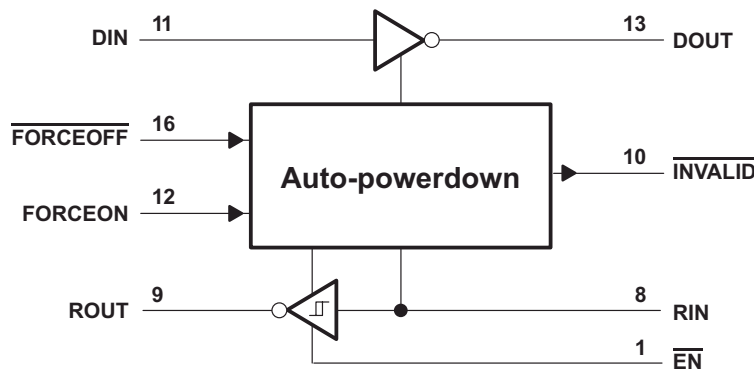
9.1 Application Information

The MAX3221 line driver and receiver is a specialized device for 3-V to 5.5-V RS-232 communication applications. This application is a generic implementation of this device with all required external components. For proper operation, add capacitors as shown in 图 9-1.

9.2 Typical Application

ROUT and DIN connect to UART or general purpose logic lines. FORCEON and FORCEOFF may be connected to general purpose logic lines or tied to ground or V_{CC}. INVALID may be connected to a general purpose logic line or left unconnected. RIN and DOUT lines connect to a RS232 connector or cable. DIN, FORCEON, and FORCEOFF inputs must not be left unconnected.

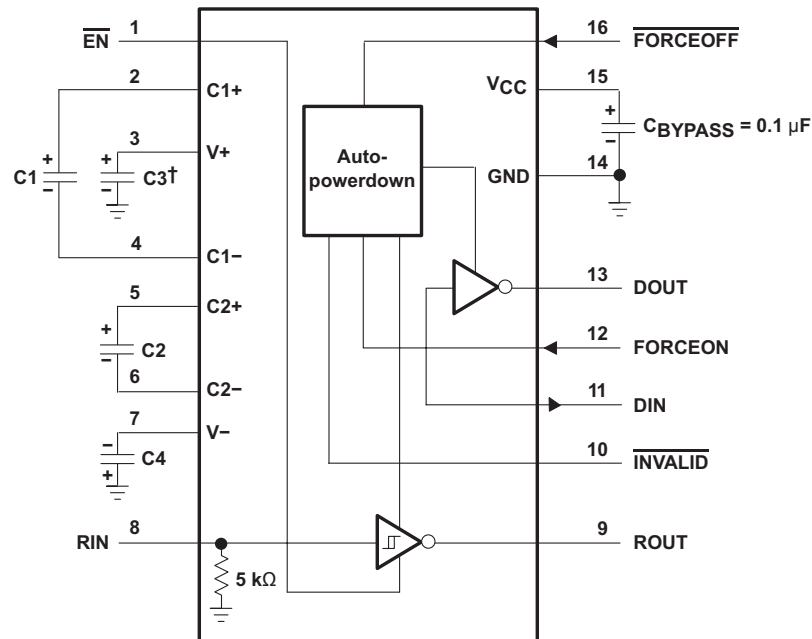

† C3 can be connected to V_{CC} or GND.

NOTES: A. Resistor values shown are nominal.

B. Nonpolarized ceramic capacitors are acceptable. If polarized tantalum or electrolytic capacitors are used, they should be connected as shown.

V_{CC} vs CAPACITOR VALUES

V _{CC}	C1	C2, C3, and C4
3.3 V ± 0.3 V	0.1 μF	0.1 μF
5 V ± 0.5 V	0.047 μF	0.33 μF
3 V to 5.5 V	0.1 μF	0.47 μF

图 9-1. Typical Operating Circuit and Capacitor Values

9.2.1 Design Requirements

- Recommended V_{CC} is 3.3 V or 5 V.
 - 3 V to 5.5 V is also possible
- Maximum recommended bit rate is 250 kbps.
- Use capacitors as shown in [图 9-1](#).

9.2.2 Detailed Design Procedure

- DIN, $\overline{\text{FORCEOFF}}$ and FORCEON inputs must be connected to valid low or high logic levels.
- Select capacitor values based on V_{CC} level for best performance.

9.2.3 Application Curve

Curves for V_{CC} of 3.3 V and 250 kbps alternative bit data stream.



图 9-2. 250-kbps Driver to Receiver Loopback Timing Waveform, $V_{CC} = 3.3 \text{ V}$

10 Power Supply Recommendations

TI recommends a 0.1- μF capacitor to filter noise on the power supply pin. For additional filter capability, a 0.01- μF capacitor may be added in parallel as well. Power supply input voltage is recommended to be any valid level in [Recommended Operating Conditions](#).

11 Layout

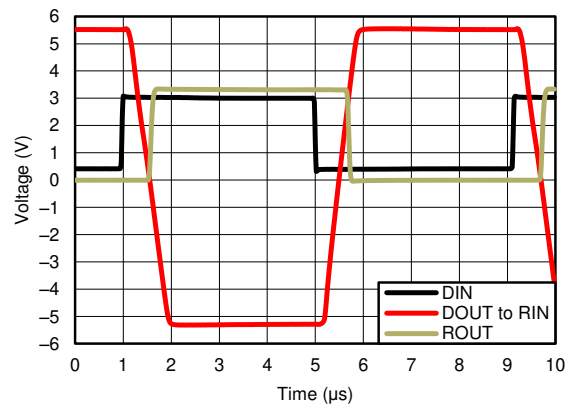
11.1 Layout Guidelines

Keep the external capacitor traces short. This is more important on C1 and C2 nodes that have the fastest rise and fall times.

11.2 Layout Example



图 11-1. Layout Diagram

12 Device and Documentation Support

12.1 支持资源

TI E2E™ 支持论坛是工程师的重要参考资料，可直接从专家获得快速、经过验证的解答和设计帮助。搜索现有解答或提出自己的问题可获得所需的快速设计帮助。

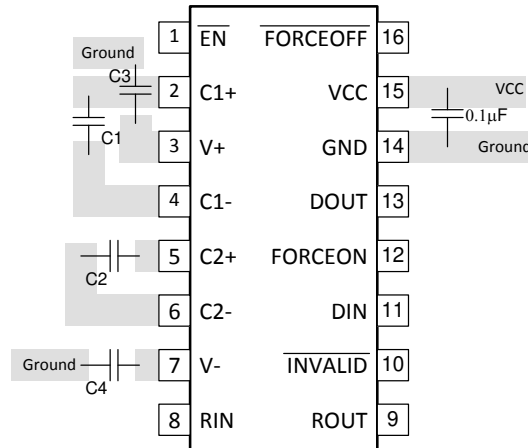
链接的内容由各个贡献者“按原样”提供。这些内容并不构成 TI 技术规范，并且不一定反映 TI 的观点；请参阅 TI 的《使用条款》。

12.2 Trademarks

TI E2E™ is a trademark of Texas Instruments.

所有商标均为其各自所有者的财产。

12.3 静电放电警告



静电放电 (ESD) 会损坏这个集成电路。德州仪器 (TI) 建议通过适当的预防措施处理所有集成电路。如果不遵守正确的处理和安装程序，可能会损坏集成电路。

ESD 的损坏小至导致微小的性能降级，大至整个器件故障。精密的集成电路可能更容易受到损坏，这是因为非常细微的参数更改都可能会导致器件与其发布的规格不相符。

12.4 术语表

[TI 术语表](#) 本术语表列出并解释了术语、首字母缩略词和定义。

13 Mechanical, Packaging, and Orderable Information

The following pages include mechanical packaging and orderable information. This information is the most current data available for the designated devices. This data is subject to change without notice and revision of this document. For browser based versions of this data sheet, refer to the left hand navigation.

PACKAGING INFORMATION

Orderable Device	Status (1)	Package Type	Package Drawing	Pins	Package Qty	Eco Plan (2)	Lead finish/ Ball material (6)	MSL Peak Temp (3)	Op Temp (°C)	Device Marking (4/5)	Samples
MAX3221CDBR	ACTIVE	SSOP	DB	16	2000	RoHS & Green	NIPDAU	Level-1-260C-UNLIM	0 to 70	MA3221C	Samples
MAX3221CDBRG4	ACTIVE	SSOP	DB	16	2000	RoHS & Green	NIPDAU	Level-1-260C-UNLIM	0 to 70	MA3221C	Samples
MAX3221CPWR	ACTIVE	TSSOP	PW	16	2000	RoHS & Green	NIPDAU	Level-1-260C-UNLIM	0 to 70	MA3221C	Samples
MAX3221CPWRE4	ACTIVE	TSSOP	PW	16	2000	RoHS & Green	NIPDAU	Level-1-260C-UNLIM	0 to 70	MA3221C	Samples
MAX3221CPWRG4	ACTIVE	TSSOP	PW	16	2000	RoHS & Green	NIPDAU	Level-1-260C-UNLIM	0 to 70	MA3221C	Samples
MAX3221IDBR	ACTIVE	SSOP	DB	16	2000	RoHS & Green	NIPDAU	Level-1-260C-UNLIM	-40 to 85	MB3221I	Samples
MAX3221IDBRE4	ACTIVE	SSOP	DB	16	2000	RoHS & Green	NIPDAU	Level-1-260C-UNLIM	-40 to 85	MB3221I	Samples
MAX3221IDBRG4	ACTIVE	SSOP	DB	16	2000	RoHS & Green	NIPDAU	Level-1-260C-UNLIM	-40 to 85	MB3221I	Samples
MAX3221IPWR	ACTIVE	TSSOP	PW	16	2000	RoHS & Green	NIPDAU	Level-1-260C-UNLIM	-40 to 85	MB3221I	Samples
MAX3221IPWRG4	ACTIVE	TSSOP	PW	16	2000	RoHS & Green	NIPDAU	Level-1-260C-UNLIM	-40 to 85	MB3221I	Samples

(1) The marketing status values are defined as follows:

ACTIVE: Product device recommended for new designs.

LIFEBUY: TI has announced that the device will be discontinued, and a lifetime-buy period is in effect.

NRND: Not recommended for new designs. Device is in production to support existing customers, but TI does not recommend using this part in a new design.

PREVIEW: Device has been announced but is not in production. Samples may or may not be available.

OBSOLETE: TI has discontinued the production of the device.

(2) **RoHS:** TI defines "RoHS" to mean semiconductor products that are compliant with the current EU RoHS requirements for all 10 RoHS substances, including the requirement that RoHS substance do not exceed 0.1% by weight in homogeneous materials. Where designed to be soldered at high temperatures, "RoHS" products are suitable for use in specified lead-free processes. TI may reference these types of products as "Pb-Free".

RoHS Exempt: TI defines "RoHS Exempt" to mean products that contain lead but are compliant with EU RoHS pursuant to a specific EU RoHS exemption.

Green: TI defines "Green" to mean the content of Chlorine (Cl) and Bromine (Br) based flame retardants meet JS709B low halogen requirements of <=1000ppm threshold. Antimony trioxide based flame retardants must also meet the <=1000ppm threshold requirement.

(3) MSL, Peak Temp. - The Moisture Sensitivity Level rating according to the JEDEC industry standard classifications, and peak solder temperature.

(4) There may be additional marking, which relates to the logo, the lot trace code information, or the environmental category on the device.

⁽⁵⁾ Multiple Device Markings will be inside parentheses. Only one Device Marking contained in parentheses and separated by a "~" will appear on a device. If a line is indented then it is a continuation of the previous line and the two combined represent the entire Device Marking for that device.

⁽⁶⁾ Lead finish/Ball material - Orderable Devices may have multiple material finish options. Finish options are separated by a vertical ruled line. Lead finish/Ball material values may wrap to two lines if the finish value exceeds the maximum column width.

Important Information and Disclaimer:The information provided on this page represents TI's knowledge and belief as of the date that it is provided. TI bases its knowledge and belief on information provided by third parties, and makes no representation or warranty as to the accuracy of such information. Efforts are underway to better integrate information from third parties. TI has taken and continues to take reasonable steps to provide representative and accurate information but may not have conducted destructive testing or chemical analysis on incoming materials and chemicals. TI and TI suppliers consider certain information to be proprietary, and thus CAS numbers and other limited information may not be available for release.

In no event shall TI's liability arising out of such information exceed the total purchase price of the TI part(s) at issue in this document sold by TI to Customer on an annual basis.

OTHER QUALIFIED VERSIONS OF MAX3221 :

- Enhanced Product : [MAX3221-EP](#)

NOTE: Qualified Version Definitions:

- Enhanced Product - Supports Defense, Aerospace and Medical Applications

TAPE AND REEL INFORMATION

QUADRANT ASSIGNMENTS FOR PIN 1 ORIENTATION IN TAPE

*All dimensions are nominal

Device	Package Type	Package Drawing	Pins	SPQ	Reel Diameter (mm)	Reel Width W1 (mm)	A0 (mm)	B0 (mm)	K0 (mm)	P1 (mm)	W (mm)	Pin1 Quadrant
MAX3221CDBR	SSOP	DB	16	2000	330.0	16.4	8.35	6.6	2.4	12.0	16.0	Q1
MAX3221CPWR	TSSOP	PW	16	2000	330.0	12.4	6.9	5.6	1.6	8.0	12.0	Q1
MAX3221CPWR	TSSOP	PW	16	2000	330.0	12.4	6.9	5.6	1.6	8.0	12.0	Q1
MAX3221IDBR	SSOP	DB	16	2000	330.0	16.4	8.35	6.6	2.4	12.0	16.0	Q1
MAX3221IPWR	TSSOP	PW	16	2000	330.0	12.4	6.9	5.6	1.6	8.0	12.0	Q1
MAX3221IPWR	TSSOP	PW	16	2000	330.0	12.4	6.9	5.6	1.6	8.0	12.0	Q1
MAX3221IPWRG4	TSSOP	PW	16	2000	330.0	12.4	6.9	5.6	1.6	8.0	12.0	Q1
MAX3221IPWRG4	TSSOP	PW	16	2000	330.0	12.4	6.9	5.6	1.6	8.0	12.0	Q1

TAPE AND REEL BOX DIMENSIONS

*All dimensions are nominal

Device	Package Type	Package Drawing	Pins	SPQ	Length (mm)	Width (mm)	Height (mm)
MAX3221CDBR	SSOP	DB	16	2000	356.0	356.0	35.0
MAX3221CPWR	TSSOP	PW	16	2000	356.0	356.0	35.0
MAX3221CPWR	TSSOP	PW	16	2000	356.0	356.0	35.0
MAX3221IDBR	SSOP	DB	16	2000	356.0	356.0	35.0
MAX3221IPWR	TSSOP	PW	16	2000	356.0	356.0	35.0
MAX3221IPWR	TSSOP	PW	16	2000	356.0	356.0	35.0
MAX3221IPWRG4	TSSOP	PW	16	2000	356.0	356.0	35.0
MAX3221IPWRG4	TSSOP	PW	16	2000	356.0	356.0	35.0



4220204/A 02/2017

NOTES:

1. All linear dimensions are in millimeters. Any dimensions in parenthesis are for reference only. Dimensioning and tolerancing per ASME Y14.5M.
2. This drawing is subject to change without notice.
3. This dimension does not include mold flash, protrusions, or gate burrs. Mold flash, protrusions, or gate burrs shall not exceed 0.15 mm per side.
4. This dimension does not include interlead flash. Interlead flash shall not exceed 0.25 mm per side.
5. Reference JEDEC registration MO-153.

EXAMPLE BOARD LAYOUT

PW0016A

TSSOP - 1.2 mm max height

SMALL OUTLINE PACKAGE



LAND PATTERN EXAMPLE
EXPOSED METAL SHOWN
SCALE: 10X



SOLDER MASK DETAILS

4220204/A 02/2017

NOTES: (continued)

- 6. Publication IPC-7351 may have alternate designs.
- 7. Solder mask tolerances between and around signal pads can vary based on board fabrication site.

EXAMPLE STENCIL DESIGN

PW0016A

TSSOP - 1.2 mm max height

SMALL OUTLINE PACKAGE



SOLDER PASTE EXAMPLE
BASED ON 0.125 mm THICK STENCIL
SCALE: 10X

4220204/A 02/2017

NOTES: (continued)

8. Laser cutting apertures with trapezoidal walls and rounded corners may offer better paste release. IPC-7525 may have alternate design recommendations.
9. Board assembly site may have different recommendations for stencil design.

DB0016A



PACKAGE OUTLINE

SSOP - 2 mm max height

SMALL OUTLINE PACKAGE



4220763/A 05/2022

NOTES:

1. All linear dimensions are in millimeters. Any dimensions in parenthesis are for reference only. Dimensioning and tolerancing per ASME Y14.5M.
2. This drawing is subject to change without notice.
3. This dimension does not include mold flash, protrusions, or gate burrs. Mold flash, protrusions, or gate burrs shall not exceed 0.15 mm per side.
4. Reference JEDEC registration MO-150.

EXAMPLE BOARD LAYOUT

DB0016A

SSOP - 2 mm max height

SMALL OUTLINE PACKAGE



LAND PATTERN EXAMPLE
EXPOSED METAL SHOWN
SCALE: 10X



4220763/A 05/2022

NOTES: (continued)

- 5. Publication IPC-7351 may have alternate designs.
- 6. Solder mask tolerances between and around signal pads can vary based on board fabrication site.

EXAMPLE STENCIL DESIGN

DB0016A

SSOP - 2 mm max height

SMALL OUTLINE PACKAGE

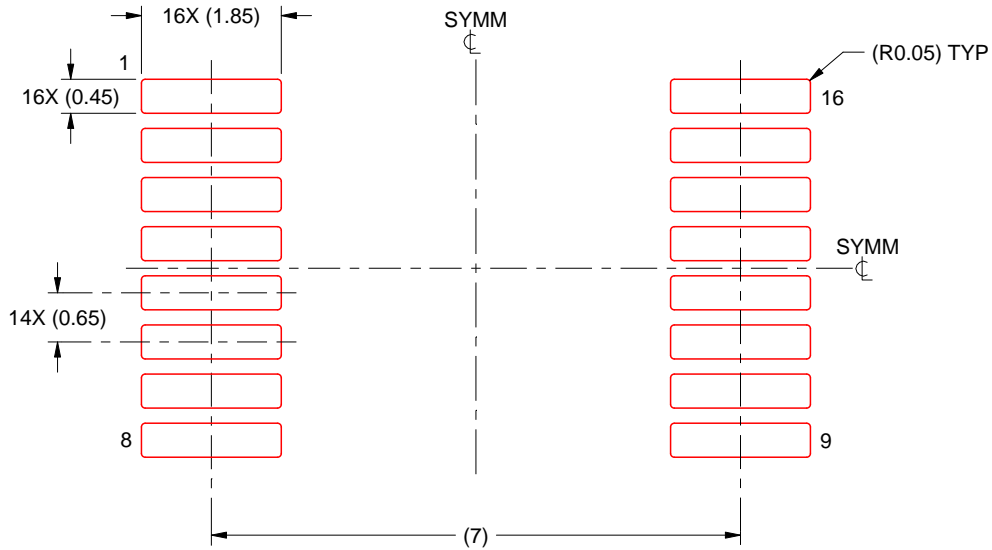

SOLDER PASTE EXAMPLE
BASED ON 0.125 mm THICK STENCIL
SCALE: 10X

4220763/A 05/2022

NOTES: (continued)

7. Laser cutting apertures with trapezoidal walls and rounded corners may offer better paste release. IPC-7525 may have alternate design recommendations.
8. Board assembly site may have different recommendations for stencil design.

重要声明和免责声明

TI“按原样”提供技术和可靠性数据（包括数据表）、设计资源（包括参考设计）、应用或其他设计建议、网络工具、安全信息和其他资源，不保证没有瑕疵且不做任何明示或暗示的担保，包括但不限于对适销性、某特定用途方面的适用性或不侵犯任何第三方知识产权的暗示担保。

这些资源可供使用 TI 产品进行设计的熟练开发人员使用。您将自行承担以下全部责任：(1) 针对您的应用选择合适的 TI 产品，(2) 设计、验证并测试您的应用，(3) 确保您的应用满足相应标准以及任何其他功能安全、信息安全、监管或其他要求。

这些资源如有变更，恕不另行通知。TI 授权您仅可将这些资源用于研发本资源所述的 TI 产品的应用。严禁对这些资源进行其他复制或展示。您无权使用任何其他 TI 知识产权或任何第三方知识产权。您应全额赔偿因在这些资源的使用中对 TI 及其代表造成的任何索赔、损害、成本、损失和债务，TI 对此概不负责。

TI 提供的产品受 [TI 的销售条款](#) 或 [ti.com](#) 上其他适用条款/TI 产品随附的其他适用条款的约束。TI 提供这些资源并不会扩展或以其他方式更改 TI 针对 TI 产品发布的适用的担保或担保免责声明。

TI 反对并拒绝您可能提出的任何其他或不同的条款。

邮寄地址：Texas Instruments, Post Office Box 655303, Dallas, Texas 75265

Copyright © 2023，德州仪器 (TI) 公司