

SNx5C116x 双路差分驱动器和接收器

1 特性

- 达到或超出 TIA/EIA-422-B 和 ITU Recommendation V.11 标准的要求
- BiCMOS 工艺技术
- 低电源电流要求：9mA (最大值)
- 低脉冲偏斜
- 接收器输入阻抗：17kΩ (典型值)
- 接收器输入灵敏度：±200mV
- 接收器共模输入电压范围为 -7V 至 7V
- 使用 5V 单电源供电
- 无干扰上电和断电保护
- 接收器三态输出低电平有效使能 (仅限 SN65C1167 和 SN75C1167)
- MC34050 和 MC34051 的改良替代品

2 应用

- 电机驱动器
- 工厂自动化
- 楼宇自动化

3 说明

SN65C1167、SN75C1167、SN65C1168 和 SN75C1168 双路驱动器和接收器是专为平衡传输线路而设计的集成电路。这些器件符合 TIA/EIA-422-B 和 ITU 建议 V.11 的要求。

SN65C1167 和 SN75C1167 整合了双三态差分线路驱动器和三态差分线路接收器，两者均采用 5V 单电源供电。驱动器和接收器分别具有高电平有效和低电平有效使能端，它们可以在外部连接在一起，用作方向控制。SN65C1168 和 SN75C1168 驱动器具有单独的高电平有效使能端。

封装信息

器件型号	封装 ⁽¹⁾	封装尺寸 ⁽²⁾
SN65C1167	DB (SSOP)	6.2mm x 5.30mm
	NS (SOP)	10.3mm x 5.30mm
SN75C1167	DB (SSOP)	6.2mm x 5.30mm
	N (PDIP)	19.3mm x 6.35mm
	NS (SOP)	10.3mm x 5.30mm
SN65C1168	N (PDIP)	19.3mm x 6.35mm
	NS (SOP)	10.3mm x 5.30mm
	PW (TSSOP)	5mm x 4.40mm
SN75C1168	DB (SSOP)	6.2mm x 5.30mm
	N (PDIP)	19.3mm x 6.35mm
	NS (SOP)	10.3mm x 5.30mm
	PW (TSSOP)	5mm x 4.4mm

(1) 有关更多信息，请参阅节 10。

(2) 封装尺寸 (长 x 宽) 为标称值，并包括引脚 (如适用)。

SN65C1167, SN75C1167

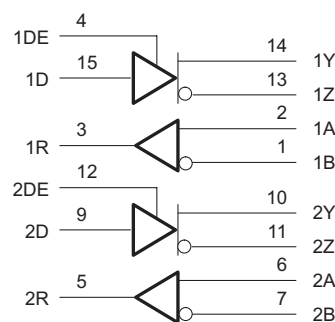
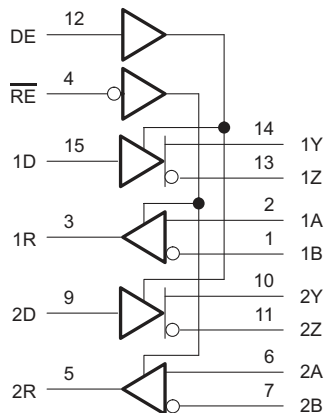

逻辑图 (正逻辑)



Table of Contents

1 特性	1	7 Detailed Description	12
2 应用	1	7.1 Functional Block Diagram.....	12
3 说明	1	7.2 Device Functional Modes.....	13
4 Pin Configuration and Functions	3	8 Device and Documentation Support	14
5 Specifications	5	8.1 Documentation Support.....	14
5.1 Absolute Maximum Ratings.....	5	8.2 接收文档更新通知.....	14
5.2 ESD Ratings.....	5	8.3 支持资源.....	14
5.3 Recommended Operating Conditions.....	5	8.4 Trademarks.....	14
5.4 Thermal Information.....	6	8.5 静电放电警告.....	14
5.5 Electrical Characteristics, Driver Section ⁽²⁾	6	8.6 术语表.....	14
5.6 Switching Characteristics.....	8	9 Revision History	14
5.7 Electrical Characteristics, Receiver Section.....	8	10 Mechanical, Packaging, and Orderable Information	14
5.8 Switching Characteristics.....	9		
6 Parameter Measurement Information	10		

4 Pin Configuration and Functions



图 4-1. SN65C1167: DB or NS Package
SN75C1167: DB, N, or NS Package
(Top View)

表 4-1. Pin Functions, SNx5C1167

PIN		TYPE ⁽¹⁾	DESCRIPTION
NAME	NO.		
1B	1	I	Inverting Input of Channel 1 Differential Receiver
1A	2	I	Non-Inverting Input of Channel 1 Differential Receiver
1R	3	O	Single Ended Receiver Output for Channel 1
RE	4	I	Receiver Active Low Enable Input for Channel 1 and 2
2R	5	O	Single Ended Receiver Output for Channel 2
2A	6	I	Non-Inverting Input of Channel 1 Differential Receiver
2B	7	I	Inverting Input of Channel 2 Differential Receiver
GND	8	G	Device Ground
2D	9	I	Single Ended Driver Input for Channel 2
2Y	10	O	Non-Inverting Output of Channel 2 Differential Driver
2Z	11	O	Inverting Output of Channel 2 Differential Driver
DE	12	I	Driver Active High Enable Input for Channel 1 and 2
1Z	13	O	Inverting Output of Channel 1 Differential Driver
1Y	14	O	Non-Inverting Output of Channel 1 Differential Driver
1D	15	I	Single Ended Driver Input for Channel 1
V _{CC}	16	P	Device VCC, connect 4.5V to 5.5V Source between this Pin and Device Ground

(1) I = Input, O = Output, I/O = Input or Output, G = Ground, P = Power.

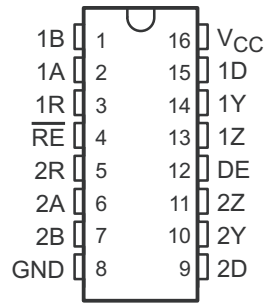
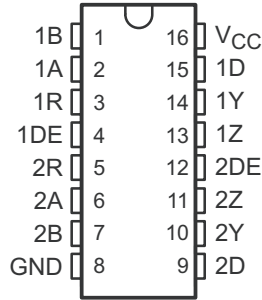

**图 4-2. SN65C1168: N, NS, or PW Package
 SN75C1168: DB, N, NS, or PW Package
 (Top View)**

表 4-2. Pin Functions, SNx5C1168

PIN		TYPE ⁽¹⁾	DESCRIPTION
NAME	NO.		
1B	1	I	Inverting Input of Channel 1 Differential Receiver
1A	2	I	Non-Inverting Input of Channel 1 Differential Receiver
1R	3	O	Single Ended Receiver Output for Channel 1
1DE	4	I	Driver Active High Enable Input for Channel 1
2R	5	O	Single Ended Receiver Output for Channel 2
2A	6	I	Non-Inverting Input of Channel 1 Differential Receiver
2B	7	I	Inverting Input of Channel 2 Differential Receiver
GND	8	G	Device Ground
2D	9	I	Single Ended Driver Input for Channel 2
2Y	10	O	Non-Inverting Output of Channel 2 Differential Driver
2Z	11	O	Inverting Output of Channel 2 Differential Driver
2DE	12	I	Driver Active High Enable Input for Channel 2
1Z	13	O	Inverting Output of Channel 1 Differential Driver
1Y	14	O	Non-Inverting Output of Channel 1 Differential Driver
1D	15	I	Single Ended Driver Input for Channel 1
V _{CC}	16	P	Device VCC, connect 4.5V to 5.5V Source between this Pin and Device Ground

(1) I = Input, O = Output, I/O = Input or Output, G = Ground, P = Power.

5 Specifications

5.1 Absolute Maximum Ratings

over operating free-air temperature range (unless otherwise noted)⁽¹⁾

			MIN	MAX	UNIT
V _{CC}	Supply voltage range ⁽²⁾		- 0.5	7	V
V _I	Input voltage range	Driver	- 0.5	V _{CC} + 0.5	V
		A or B, Receiver	- 11	14	
V _{ID}	Differential input voltage range ⁽³⁾	Receiver	- 14	14	V
V _O	Output voltage range	Driver	- 0.5	7	V
I _{IK} or I _{OK}	Clamp current range	Driver		±20	mA
I _O	Output current range	Driver		±150	mA
		Receiver		±25	
I _{CC}	Supply current			200	mA
	GND current			-200	
T _J	Operating virtual junction temperature			150	°C
T _{stg}	Storage temperature range		- 65	150	°C

- (1) Stresses beyond those listed under *Absolute Maximum Ratings* may cause permanent damage to the device. These are stress ratings only, which do not imply functional operation of the device at these or any other conditions beyond those indicated under *Recommended Operating Conditions*. Exposure to absolute-maximum-rated conditions for extended periods may affect device reliability.
- (2) All voltages values except differential input voltage are with respect to the network GND.
- (3) Differential input voltage is measured at the noninverting terminal with respect to the inverting terminal.

5.2 ESD Ratings

			VALUE	UNIT
V _(ESD)	Electrostatic discharge	Human-body model (HBM), per ANSI/ESDA/JEDEC JS-001 ⁽¹⁾	± 8kV	V
		Charged-device model (CDM), per JEDEC specification JESD22-C101 ⁽²⁾	± 1kV	

- (1) JEDEC document JEP155 states that 500V HBM allows safe manufacturing with a standard ESD control process.
- (2) JEDEC document JEP157 states that 250V CDM allows safe manufacturing with a standard ESD control process.

5.3 Recommended Operating Conditions

over operating free-air temperature range (unless otherwise noted)

			MIN	NOM	MAX	UNIT
V _{CC}	Supply voltage		4.5	5	5.5	V
V _{IC}	Common-mode input voltage ⁽¹⁾	Receiver			±7	V
V _{ID}	Differential input voltage	Receiver			±7	V
V _{IH}	High-level input voltage	Except A, B	2			V
V _{IL}	Low-level input voltage	Except A, B			0.8	V
I _{OH}	High-level output current	Receiver			-6	mA
		Driver			-20	
I _{OL}	Low-level output current	Receiver			6	mA
		Driver			20	

5.3 Recommended Operating Conditions (续)

over operating free-air temperature range (unless otherwise noted)

		MIN	NOM	MAX	UNIT	
T _A	Operating free-air temperature	SN75C1167, SN75C1168		0	70	°C
		SN65C1167, SN65C1168		-40	85	

(1) Refer to TIA/EIA-422-B for exact conditions.

5.4 Thermal Information

THERMAL METRIC ⁽¹⁾		DB (SSOP)	N (PDIP)	NS (SOP)	PW (TSSOP)	UNIT
		16 PINS	16 PINS	16 PINS	16 PINS	
R _{θJA}	Junction-to-ambient thermal resistance	102.6	60.6	88.5	107.5	°C/W
R _{θJC(top)}	Junction-to-case (top) thermal resistance	48.7	48.1	46.2	38.4	°C/W
R _{θJB}	Junction-to-board thermal resistance	54.3	40.6	50.7	53.7	°C/W
ψ _{JT}	Junction-to-top characterization parameter	11.8	27.5	13.5	3.2	°C/W
ψ _{JB}	Junction-to-board characterization parameter	53.5	40.3	50.3	53.1	°C/W
R _{θJC(bot)}	Junction-to-case (bottom) thermal resistance	N/A	N/A	N/A	N/A	°C/W

(1) For more information about traditional and new thermal metrics, see the [Semiconductor and IC Package Thermal Metrics application report](#).

5.5 Electrical Characteristics, Driver Section⁽²⁾

over recommended ranges of supply voltage and operating free-air temperature (unless otherwise noted)

PARAMETER		TEST CONDITIONS		MIN	TYP ⁽¹⁾	MAX	UNIT	
V _{IK}	Input clamp voltage	I _I = -18mA				-1.5	V	
V _{OH}	High-level output voltage	V _{IH} = 2V, V _{IL} = 0.8V, I _{OH} = -20mA		2.4	3.4		V	
V _{OL}	Low-level output voltage	V _{IH} = 2V, V _{IL} = 0.8V, I _{OL} = 20mA			0.2	0.4	V	
V _{OD1}	Differential output voltage	I _O = 0mA		2		6	V	
V _{OD2}	Differential output voltage ⁽²⁾	R _L = 100Ω, See 图 6-1		2	3.1		V	
Δ V _{OD}	Change in magnitude of differential output voltage						±0.4	V
V _{OC}	Common-mode output voltage						±3	V
Δ V _{Ocl}	Change in magnitude of common-mode output voltage						±0.4	V
I _{O(OFF)}	Output current with power off	V _{CC} = 0V	V _O = 6V V _O = -0.25V			100 -100	μA	
I _{OZ}	High-impedance-state output current	V _O = 2.5				20	μA	
		V _O = 5				-20		
I _{IH}	High-level input current	V _I = V _{CC} or V _{IH}				1	μA	
I _{IL}	Low-level input current	V _I = GND or V _{IL}				-1	μA	
I _{OS}	Short-circuit output current ⁽³⁾	V _O = V _{CC} or GND,		-30		-150	mA	
I _{CC}	Supply current (total package) ⁽⁴⁾	No load, Enabled	V _I = V _{CC} or GND		4	6	mA	
			V _I = 2.4 or 0.5V		5	9		
C _i	Input capacitance				6		pF	

(1) All typical values are at V_{CC} = 5V, and T_A = 25°C.

(2) Refer to TIA/EIA-422-B for exact conditions.

(3) Not more than one output should be shorted at a time, and the duration of the short circuit should not exceed one second.

(4) This parameter is measured per input, while the other inputs are at V_{CC} or GND.

5.6 Switching Characteristics

over recommended ranges of supply voltage and operating free-air temperature (unless otherwise noted)

PARAMETER		TEST CONDITIONS		MIN	TYP ⁽¹⁾	MAX	UNIT
t_{PHL}	Propagation delay time, high- to low-level output	R1 = R2 = 50 Ω , C1 = C2 = C3 = 40pF, See 图 6-2	R3 = 500 Ω , S1 is open,		7	12	ns
t_{PLH}	Propagation delay time, low- to high-level output				7	12	ns
$t_{sk(p)}$	Pulse skew				0.5	4	ns
t_r	Rise time	R1 = R2 = 50 Ω , C1 = C2 = C3 = 40pF, See 图 6-3	R3 = 500 Ω , S1 is open,		5	10	ns
t_f	Fall time				5	10	ns
t_{PZH}	Output enable time to high level	R1 = R2 = 50 Ω , C1 = C2 = C3 = 40pF, See 图 6-4	R3 = 500 Ω , S1 is closed,		10	19	ns
t_{PZL}	Output enable time to low level				10	19	ns
t_{PHZ}	Output disable time from low level	R1 = R2 = 50 Ω , C1 = C2 = C3 = 40pF, See 图 6-4	R3 = 500 Ω , S1 is closed,		7	16	ns
t_{PLZ}	Output disable time from high level				7	16	ns

(1) All typical values are at $V_{CC} = 5V$, and $T_A = 25^\circ C$.

5.7 Electrical Characteristics, Receiver Section

over recommended ranges of supply voltage and operating free-air temperature (unless otherwise noted)

PARAMETER		TEST CONDITIONS		MIN	TYP ⁽¹⁾	MAX	UNIT
V_{IT+}	Positive-going input threshold voltage, differential input					0.2	V
V_{IT-}	Negative-going input threshold voltage, differential input			-0.2 ⁽²⁾			V
V_{hys}	Input hysteresis ($V_{IT+} - V_{IT-}$)				60		mV
V_{IK}	Input clamp voltage, \overline{RE}	SN75C1167	$I_I = -18$ mA			-1.5	V
V_{OH}	High-level output voltage		$V_{ID} = 200$ mV, $I_{OH} = -6$ mA	3.8	4.2		V
V_{OL}	Low-level output voltage		$V_{ID} = -200$ mV, $I_{OL} = 6$ mA		0.1	0.3	V
I_{OZ}	High-impedance-state output current	SN75C1167	$V_O = V_{CC}$ or GND		± 0.5	± 5	μA
I_I	Line input current		Other input at 0 V			1.5	mA
						-2.5	
I_I	Enable input current, \overline{RE}	SN75C1167	$V_I = V_{CC}$ or GND			± 1	μA
r_i	Input resistance		$V_{IC} = -7$ V to 7 V, Other input at 0 V	4	17		k Ω
I_{CC}	Supply current (total package)		No load, Enabled			4	mA
						5	

(1) All typical values are at $V_{CC} = 5V$ and $T_A = 25^\circ C$.

(2) The algebraic convention, where the less positive (more negative) limit is designated as minimum, is used in this data sheet for common-mode input voltage and threshold voltage levels only.

(3) Refer to TIA/EIA-422-B for exact conditions.

5.8 Switching Characteristics

over operating free-air temperature range (unless otherwise noted) ⁽²⁾

PARAMETER		TEST CONDITIONS	MIN	TYP ⁽¹⁾	MAX	UNIT
t _{PLH}	Propagation delay time, low- to high-level output	See 图 6-5	9	17	27	ns
t _{PHL}	Propagation delay time, high- to low-level output		9	17	27	ns
t _{TLH}	Transition time, low- to high-level output	V _{IC} = 0V, See 图 6-5		4	9	ns
t _{THL}	Transition time, high- to low-level output			4	9	ns
t _{PZH}	Output enable time to high level	R _L = 1kW, See 图 6-6		13	22	ns
t _{PZL}	Output enable time to low level			13	22	ns
t _{PHZ}	Output disable time from high level			13	22	ns
t _{PLZ}	Output disable time from low level			13	22	ns

(1) All typical values are at V_{CC} = 5V and T_A = 25°C.

(2) Measured per input while the other inputs are at V_{CC} or GND

6 Parameter Measurement Information



图 6-1. Driver Test Circuit, V_{OD} and V_{OC}



- A. C1, C2, and C3 include probe and jig capacitance.
 B. The input pulse is supplied by a generator having the following characteristics: PRR = 1MHz, 50% duty cycle, $t_r = t_f \leq 6\text{ns}$.

图 6-2. Driver Test Circuit and Voltage Waveforms

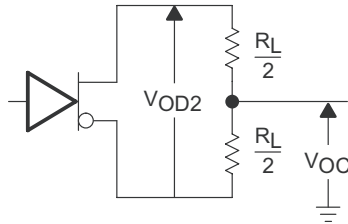
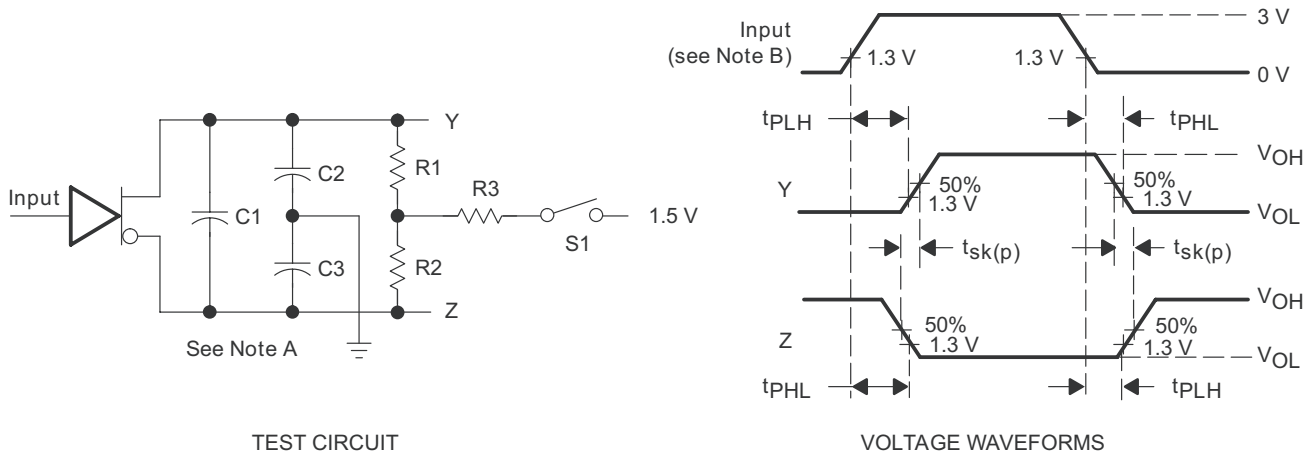
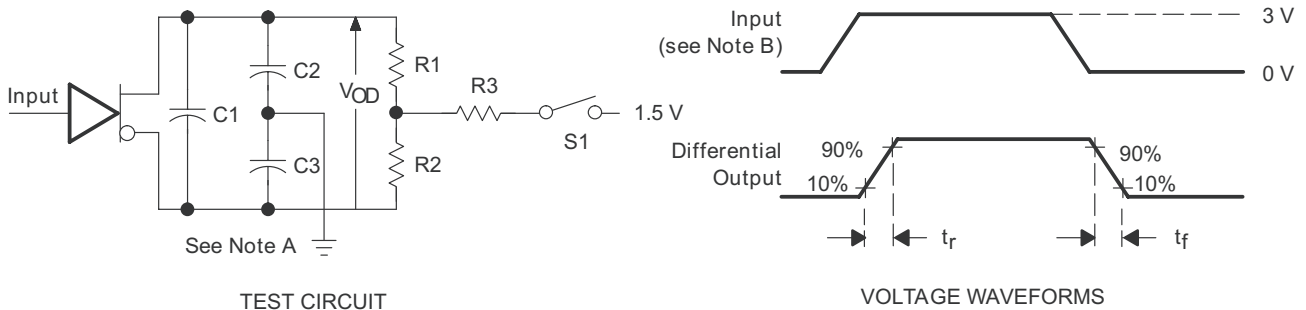

- A. C1, C2, and C3 include probe and jig capacitance.
 B. The input pulse is supplied by a generator having the following characteristics: PRR = 1MHz, 50% duty cycle, $t_r = t_f \leq 6\text{ns}$.

图 6-3. Driver Test Circuit and Voltage Waveforms

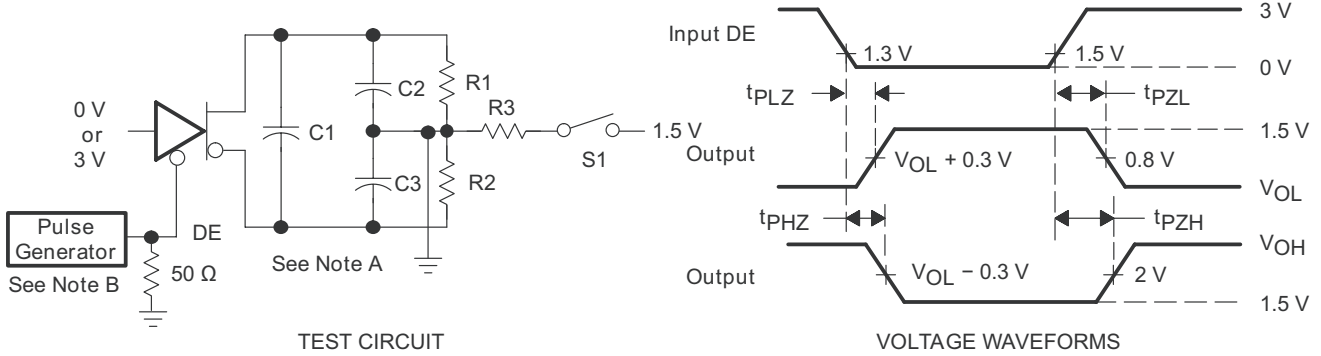

- A. C1, C2, and C3 include probe and jig capacitance.
- B. The input pulse is supplied by a generator having the following characteristics: PRR = 1MHz, 50% duty cycle, $t_r = t_f \leq 6\text{ns}$.

图 6-4. Driver Test Circuit and Voltage Waveforms

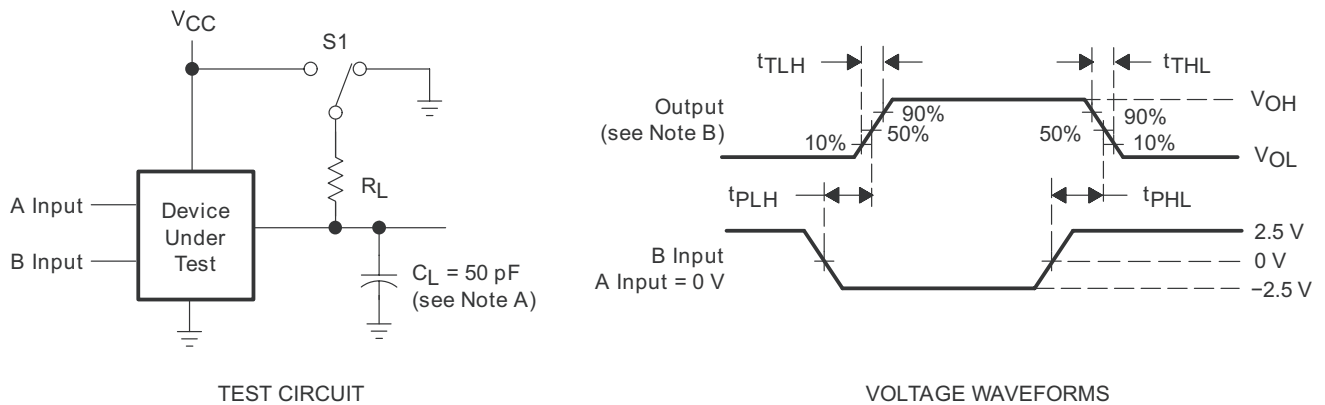

- A. C_L includes probe and jig capacitance.
- B. The input pulse is supplied by a generator having the following characteristics: PRR = 1MHz, 50% duty cycle, $t_r = t_f \leq 6\text{ns}$.

图 6-5. Receiver Test Circuit and Voltage Waveforms

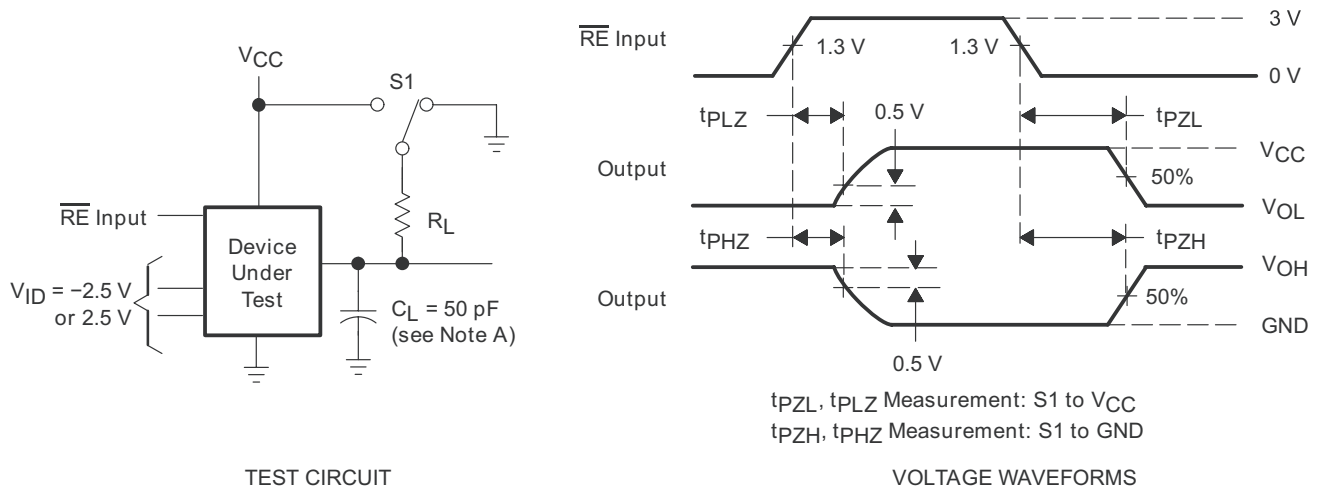

- A. C_L includes probe and jig capacitance.
- B. The input pulse is supplied by a generator having the following characteristics: PRR = 1MHz, 50% duty cycle, $t_r = t_f \leq 6\text{ns}$.

图 6-6. Receiver Test Circuit and Voltage Waveforms

7 Detailed Description

7.1 Functional Block Diagram



图 7-1. Schematic of Inputs



图 7-2. Schematic of Outputs

7.2 Device Functional Modes

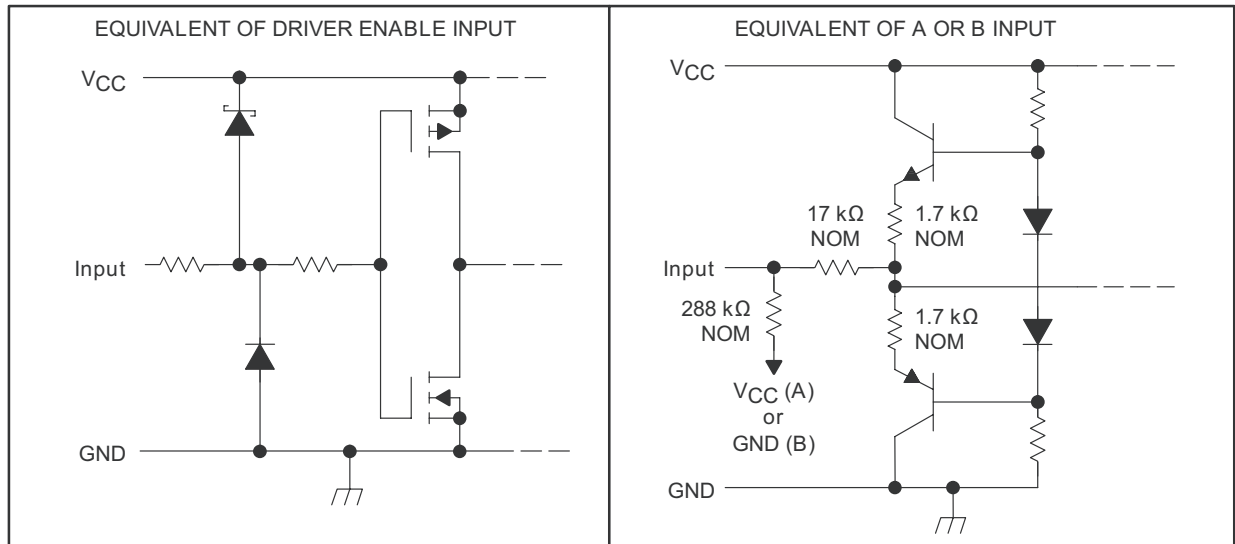
7.2.1 Functions Table

表 7-1. Each Driver⁽¹⁾

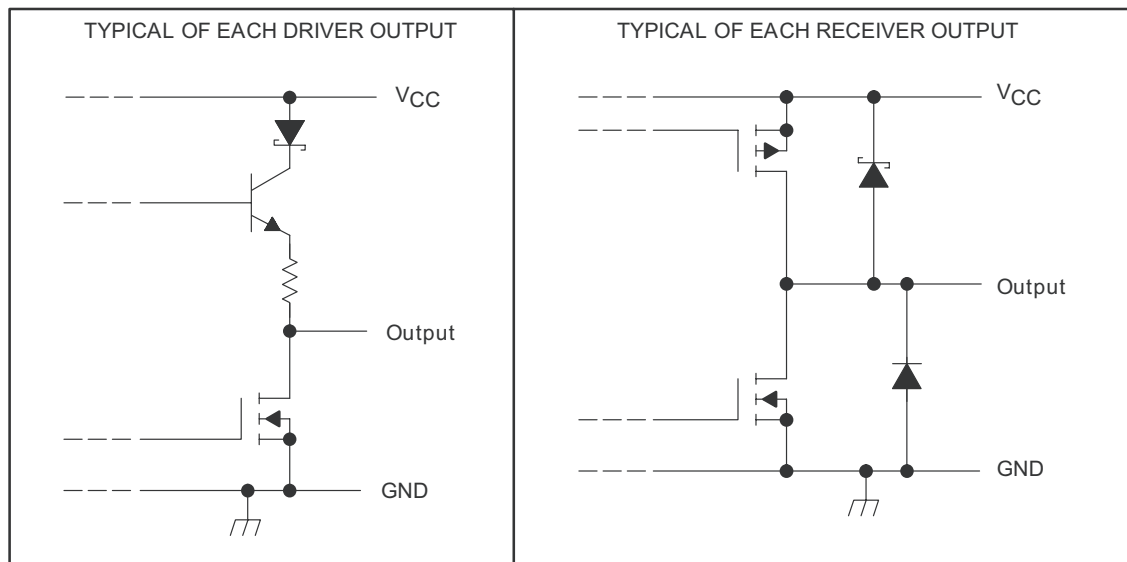
INPUT D	ENABLE DE	OUTPUTS	
		Y	Z
H	H	H	L
L	H	L	H
X	L	Z	Z

(1) H = high level, L = low level, X = irrelevant, Z = high impedance

表 7-2. Each Receiver⁽¹⁾

DIFFERENTIAL INPUTS A - B	ENABLE RE	OUTPUT R
$V_{ID} \geq 0.2V$	L	H
$-0.2V < V_{ID} < 0.2V$	L	?
$V_{ID} \leq -0.2V$	L	L
X	H	Z
Open	L	H

(1) H = high level, L = low level, ? = indeterminate, X = irrelevant,
Z = high impedance (off), Open = input disconnected or connected driver off

8 Device and Documentation Support

8.1 Documentation Support

8.2 接收文档更新通知

要接收文档更新通知，请导航至 [ti.com](https://www.ti.com) 上的器件产品文件夹。点击 [通知](#) 进行注册，即可每周接收产品信息更改摘要。有关更改的详细信息，请查看任何已修订文档中包含的修订历史记录。

8.3 支持资源

[TI E2E™ 中文支持论坛](#) 是工程师的重要参考资料，可直接从专家处获得快速、经过验证的解答和设计帮助。搜索现有解答或提出自己的问题，获得所需的快速设计帮助。

链接的内容由各个贡献者“按原样”提供。这些内容并不构成 TI 技术规范，并且不一定反映 TI 的观点；请参阅 TI 的 [使用条款](#)。

8.4 Trademarks

TI E2E™ is a trademark of Texas Instruments.

所有商标均为其各自所有者的财产。

8.5 静电放电警告



静电放电 (ESD) 会损坏这个集成电路。德州仪器 (TI) 建议通过适当的预防措施处理所有集成电路。如果不遵守正确的处理和安装程序，可能会损坏集成电路。

ESD 的损坏小至导致微小的性能降级，大至整个器件故障。精密的集成电路可能更容易受到损坏，这是因为非常细微的参数更改都可能会导致器件与其发布的规格不相符。

8.6 术语表

TI 术语表

本术语表列出并解释了术语、首字母缩略词和定义。

9 Revision History

注：以前版本的页码可能与当前版本的页码不同

Changes from Revision F (November 2009) to Revision G (February 2024)	Page
• 更改了整个文档中的表格、图和交叉参考的编号格式.....	1
• Changed the I_{CC} for $V_I = 2.4$ or $0.5V$ MAX value From: 3mA To: 9mA in the <i>Electrical Characteristics, Driver Section</i>	6

10 Mechanical, Packaging, and Orderable Information

The following pages include mechanical, packaging, and orderable information. This information is the most current data available for the designated devices. This data is subject to change without notice and revision of this document. For browser-based versions of this data sheet, refer to the left-hand navigation.

PACKAGING INFORMATION

Orderable Device	Status (1)	Package Type	Package Drawing	Pins	Package Qty	Eco Plan (2)	Lead finish/ Ball material (6)	MSL Peak Temp (3)	Op Temp (°C)	Device Marking (4/5)	Samples
SN65C1168N	ACTIVE	PDIP	N	16	25	RoHS & Green	NIPDAU	N / A for Pkg Type	-40 to 85	SN65C1168N	Samples
SN65C1168PW	OBSOLETE	TSSOP	PW	16		TBD	Call TI	Call TI	-40 to 85	CB1168	
SN65C1168PWR	OBSOLETE	TSSOP	PW	16		TBD	Call TI	Call TI	-40 to 85	CB1168	
SN75C1167DB	OBSOLETE	SSOP	DB	16		TBD	Call TI	Call TI		CA1167	
SN75C1167DBR	ACTIVE	SSOP	DB	16	2000	RoHS & Green	NIPDAU	Level-1-260C-UNLIM	0 to 70	CA1167	Samples
SN75C1167N	ACTIVE	PDIP	N	16	25	RoHS & Green	NIPDAU	N / A for Pkg Type	0 to 70	SN75C1167N	Samples
SN75C1168DBR	ACTIVE	SSOP	DB	16	2000	RoHS & Green	NIPDAU	Level-1-260C-UNLIM	0 to 70	CA1168	Samples
SN75C1168N	ACTIVE	PDIP	N	16	25	RoHS & Green	NIPDAU	N / A for Pkg Type	0 to 70	SN75C1168N	Samples
SN75C1168NE4	ACTIVE	PDIP	N	16	25	RoHS & Green	NIPDAU	N / A for Pkg Type	0 to 70	SN75C1168N	Samples
SN75C1168NS	ACTIVE	SO	NS	16	50	RoHS & Green	NIPDAU	Level-1-260C-UNLIM	0 to 70	75C1168	Samples
SN75C1168NSR	OBSOLETE	SO	NS	16		TBD	Call TI	Call TI	0 to 70	75C1168	
SN75C1168PW	OBSOLETE	TSSOP	PW	16		TBD	Call TI	Call TI	0 to 70	CA1168	

(1) The marketing status values are defined as follows:

ACTIVE: Product device recommended for new designs.

LIFEBUY: TI has announced that the device will be discontinued, and a lifetime-buy period is in effect.

NRND: Not recommended for new designs. Device is in production to support existing customers, but TI does not recommend using this part in a new design.

PREVIEW: Device has been announced but is not in production. Samples may or may not be available.

OBSOLETE: TI has discontinued the production of the device.

(2) **RoHS:** TI defines "RoHS" to mean semiconductor products that are compliant with the current EU RoHS requirements for all 10 RoHS substances, including the requirement that RoHS substance do not exceed 0.1% by weight in homogeneous materials. Where designed to be soldered at high temperatures, "RoHS" products are suitable for use in specified lead-free processes. TI may reference these types of products as "Pb-Free".

RoHS Exempt: TI defines "RoHS Exempt" to mean products that contain lead but are compliant with EU RoHS pursuant to a specific EU RoHS exemption.

Green: TI defines "Green" to mean the content of Chlorine (Cl) and Bromine (Br) based flame retardants meet JS709B low halogen requirements of <=1000ppm threshold. Antimony trioxide based flame retardants must also meet the <=1000ppm threshold requirement.

(3) MSL, Peak Temp. - The Moisture Sensitivity Level rating according to the JEDEC industry standard classifications, and peak solder temperature.

- (4) There may be additional marking, which relates to the logo, the lot trace code information, or the environmental category on the device.
- (5) Multiple Device Markings will be inside parentheses. Only one Device Marking contained in parentheses and separated by a "~" will appear on a device. If a line is indented then it is a continuation of the previous line and the two combined represent the entire Device Marking for that device.
- (6) Lead finish/Ball material - Orderable Devices may have multiple material finish options. Finish options are separated by a vertical ruled line. Lead finish/Ball material values may wrap to two lines if the finish value exceeds the maximum column width.

Important Information and Disclaimer:The information provided on this page represents TI's knowledge and belief as of the date that it is provided. TI bases its knowledge and belief on information provided by third parties, and makes no representation or warranty as to the accuracy of such information. Efforts are underway to better integrate information from third parties. TI has taken and continues to take reasonable steps to provide representative and accurate information but may not have conducted destructive testing or chemical analysis on incoming materials and chemicals. TI and TI suppliers consider certain information to be proprietary, and thus CAS numbers and other limited information may not be available for release.

In no event shall TI's liability arising out of such information exceed the total purchase price of the TI part(s) at issue in this document sold by TI to Customer on an annual basis.

TAPE AND REEL INFORMATION

QUADRANT ASSIGNMENTS FOR PIN 1 ORIENTATION IN TAPE

*All dimensions are nominal

Device	Package Type	Package Drawing	Pins	SPQ	Reel Diameter (mm)	Reel Width W1 (mm)	A0 (mm)	B0 (mm)	K0 (mm)	P1 (mm)	W (mm)	Pin1 Quadrant
SN75C1167DBR	SSOP	DB	16	2000	330.0	16.4	8.35	6.6	2.4	12.0	16.0	Q1
SN75C1167DBR	SSOP	DB	16	2000	330.0	16.4	8.35	6.6	2.4	12.0	16.0	Q1
SN75C1168DBR	SSOP	DB	16	2000	330.0	16.4	8.35	6.6	2.4	12.0	16.0	Q1

TAPE AND REEL BOX DIMENSIONS



*All dimensions are nominal

Device	Package Type	Package Drawing	Pins	SPQ	Length (mm)	Width (mm)	Height (mm)
SN75C1167DBR	SSOP	DB	16	2000	356.0	356.0	35.0
SN75C1167DBR	SSOP	DB	16	2000	353.0	353.0	32.0
SN75C1168DBR	SSOP	DB	16	2000	356.0	356.0	35.0

TUBE

*All dimensions are nominal

Device	Package Name	Package Type	Pins	SPQ	L (mm)	W (mm)	T (μm)	B (mm)
SN65C1168N	N	PDIP	16	25	506	13.97	11230	4.32
SN75C1167N	N	PDIP	16	25	506	13.97	11230	4.32
SN75C1168N	N	PDIP	16	25	506	13.97	11230	4.32
SN75C1168NE4	N	PDIP	16	25	506	13.97	11230	4.32
SN75C1168NS	NS	SOP	16	50	530	10.5	4000	4.1



PACKAGE OUTLINE

NS0016A

SOP - 2.00 mm max height

SOP

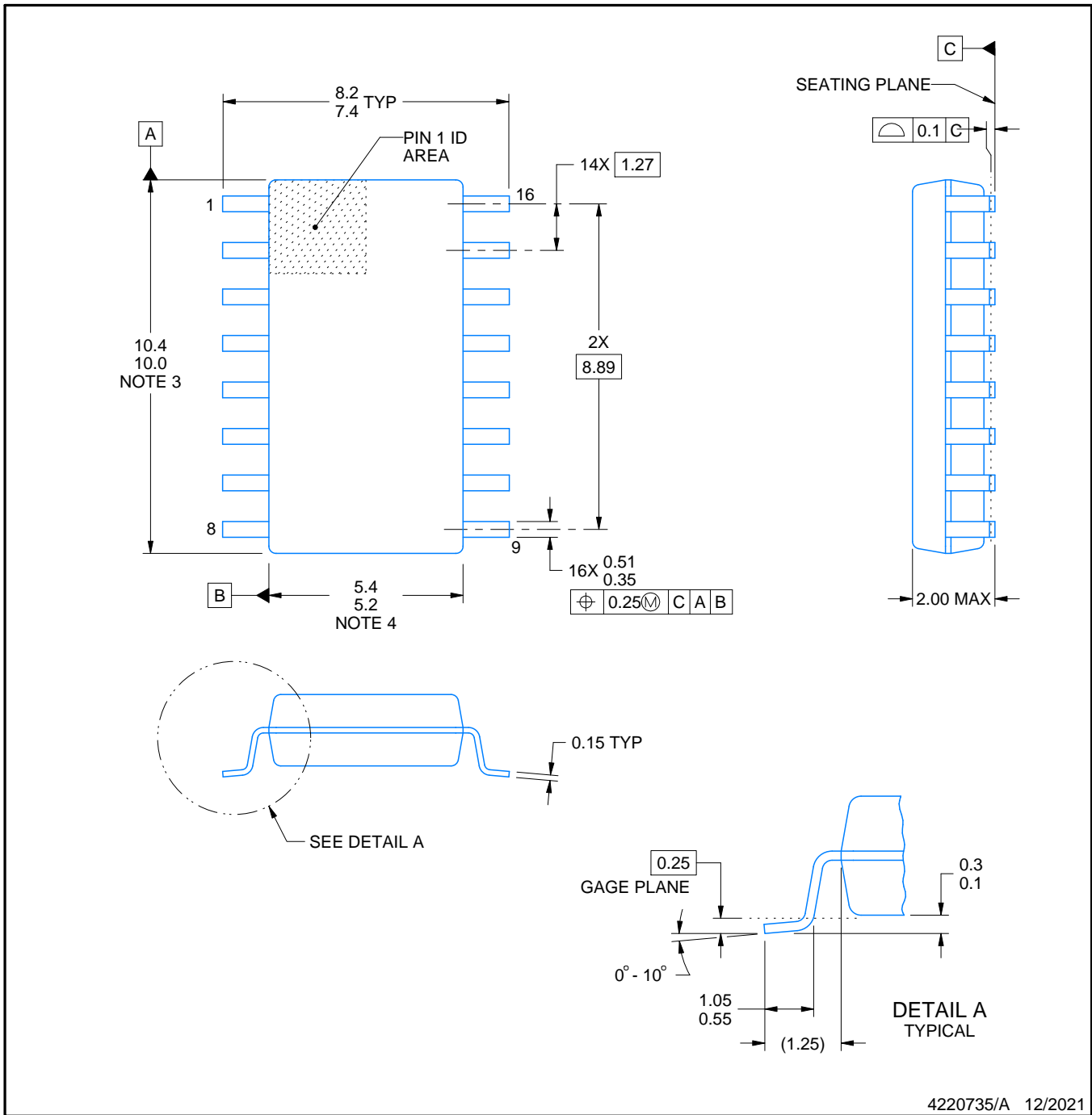

4220735/A 12/2021

NOTES:

1. All linear dimensions are in millimeters. Dimensions in parenthesis are for reference only. Dimensioning and tolerancing per ASME Y14.5M.
2. This drawing is subject to change without notice.
3. This dimension does not include mold flash, protrusions, or gate burrs. Mold flash, protrusions, or gate burrs shall not exceed 0.15 mm, per side.
4. This dimension does not include interlead flash. Interlead flash shall not exceed 0.25 mm, per side.

EXAMPLE BOARD LAYOUT

NS0016A

SOP - 2.00 mm max height

SOP



SOLDER MASK DETAILS

4220735/A 12/2021

NOTES: (continued)

5. Publication IPC-7351 may have alternate designs.

6. Solder mask tolerances between and around signal pads can vary based on board fabrication site.

EXAMPLE STENCIL DESIGN

NS0016A

SOP - 2.00 mm max height

SOP



SOLDER PASTE EXAMPLE
BASED ON 0.125 mm THICK STENCIL
SCALE:7X

4220735/A 12/2021

NOTES: (continued)

7. Laser cutting apertures with trapezoidal walls and rounded corners may offer better paste release. IPC-7525 may have alternate design recommendations.
8. Board assembly site may have different recommendations for stencil design.



4220204/A 02/2017

NOTES:

1. All linear dimensions are in millimeters. Any dimensions in parenthesis are for reference only. Dimensioning and tolerancing per ASME Y14.5M.
2. This drawing is subject to change without notice.
3. This dimension does not include mold flash, protrusions, or gate burrs. Mold flash, protrusions, or gate burrs shall not exceed 0.15 mm per side.
4. This dimension does not include interlead flash. Interlead flash shall not exceed 0.25 mm per side.
5. Reference JEDEC registration MO-153.

EXAMPLE BOARD LAYOUT

PW0016A

TSSOP - 1.2 mm max height

SMALL OUTLINE PACKAGE



LAND PATTERN EXAMPLE
EXPOSED METAL SHOWN
SCALE: 10X



4220204/A 02/2017

NOTES: (continued)

- 6. Publication IPC-7351 may have alternate designs.
- 7. Solder mask tolerances between and around signal pads can vary based on board fabrication site.

EXAMPLE STENCIL DESIGN

PW0016A

TSSOP - 1.2 mm max height

SMALL OUTLINE PACKAGE



SOLDER PASTE EXAMPLE
BASED ON 0.125 mm THICK STENCIL
SCALE: 10X

4220204/A 02/2017

NOTES: (continued)

8. Laser cutting apertures with trapezoidal walls and rounded corners may offer better paste release. IPC-7525 may have alternate design recommendations.
9. Board assembly site may have different recommendations for stencil design.

DB0016A



PACKAGE OUTLINE

SSOP - 2 mm max height

SMALL OUTLINE PACKAGE



4220763/A 05/2022

NOTES:

1. All linear dimensions are in millimeters. Any dimensions in parenthesis are for reference only. Dimensioning and tolerancing per ASME Y14.5M.
2. This drawing is subject to change without notice.
3. This dimension does not include mold flash, protrusions, or gate burrs. Mold flash, protrusions, or gate burrs shall not exceed 0.15 mm per side.
4. Reference JEDEC registration MO-150.

EXAMPLE BOARD LAYOUT

DB0016A

SSOP - 2 mm max height

SMALL OUTLINE PACKAGE



LAND PATTERN EXAMPLE
EXPOSED METAL SHOWN
SCALE: 10X



4220763/A 05/2022

NOTES: (continued)

- 5. Publication IPC-7351 may have alternate designs.
- 6. Solder mask tolerances between and around signal pads can vary based on board fabrication site.

EXAMPLE STENCIL DESIGN

DB0016A

SSOP - 2 mm max height

SMALL OUTLINE PACKAGE

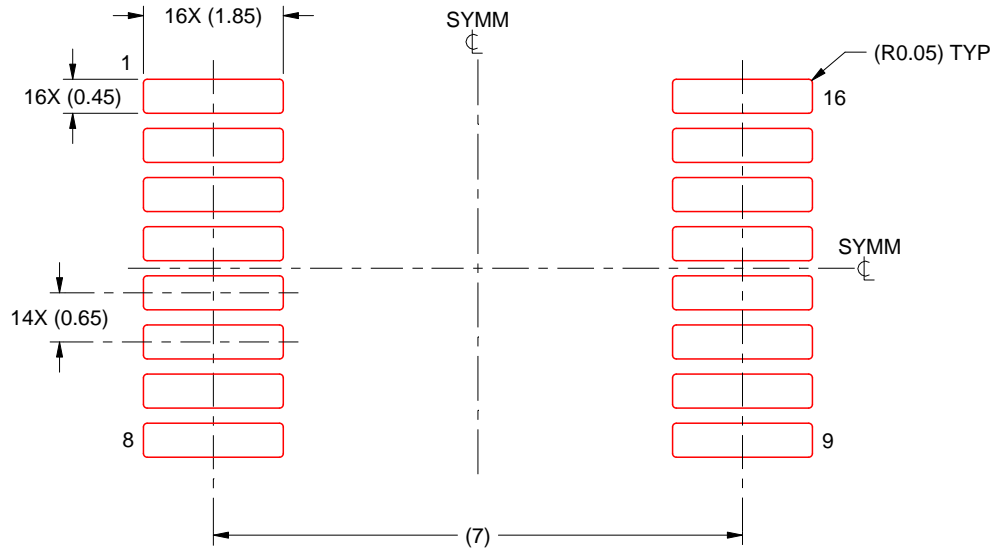

SOLDER PASTE EXAMPLE
BASED ON 0.125 mm THICK STENCIL
SCALE: 10X

4220763/A 05/2022

NOTES: (continued)

7. Laser cutting apertures with trapezoidal walls and rounded corners may offer better paste release. IPC-7525 may have alternate design recommendations.
8. Board assembly site may have different recommendations for stencil design.

MECHANICAL DATA

NS (R-PDSO-G)**

PLASTIC SMALL-OUTLINE PACKAGE

14-PINS SHOWN



- NOTES:
- A. All linear dimensions are in millimeters.
 - B. This drawing is subject to change without notice.
 - C. Body dimensions do not include mold flash or protrusion, not to exceed 0,15.

N (R-PDIP-T**)

PLASTIC DUAL-IN-LINE PACKAGE

16 PINS SHOWN



4040049/E 12/2002

- NOTES:
- A. All linear dimensions are in inches (millimeters).
 - B. This drawing is subject to change without notice.
 - $\triangle C$ Falls within JEDEC MS-001, except 18 and 20 pin minimum body length (Dim A).
 - $\triangle D$ The 20 pin end lead shoulder width is a vendor option, either half or full width.

重要声明和免责声明

TI“按原样”提供技术和可靠性数据（包括数据表）、设计资源（包括参考设计）、应用或其他设计建议、网络工具、安全信息和其他资源，不保证没有瑕疵且不做任何明示或暗示的担保，包括但不限于对适销性、某特定用途方面的适用性或不侵犯任何第三方知识产权的暗示担保。

这些资源可供使用 TI 产品进行设计的熟练开发人员使用。您将自行承担以下全部责任：(1) 针对您的应用选择合适的 TI 产品，(2) 设计、验证并测试您的应用，(3) 确保您的应用满足相应标准以及任何其他功能安全、信息安全、监管或其他要求。

这些资源如有变更，恕不另行通知。TI 授权您仅可将这些资源用于研发本资源所述的 TI 产品的应用。严禁对这些资源进行其他复制或展示。您无权使用任何其他 TI 知识产权或任何第三方知识产权。您应全额赔偿因在这些资源的使用中对 TI 及其代表造成的任何索赔、损害、成本、损失和债务，TI 对此概不负责。

TI 提供的产品受 [TI 的销售条款](#) 或 [ti.com](#) 上其他适用条款/TI 产品随附的其他适用条款的约束。TI 提供这些资源并不会扩展或以其他方式更改 TI 针对 TI 产品发布的适用的担保或担保免责声明。

TI 反对并拒绝您可能提出的任何其他或不同的条款。

邮寄地址：Texas Instruments, Post Office Box 655303, Dallas, Texas 75265

Copyright © 2024，德州仪器 (TI) 公司