

SN74AUP1T08 低功耗、1.8/2.5/3.3V 输入、3.3V CMOS 输出、单路 2 输入{1}正与门

1 特性

- 静电放电 (ESD) 性能测试符合 JESD 22 标准
 - 2000V 人体放电模型{1} (A114-B, II 类)
 - 1000V 充电器件模型 (C101)
- 单电源电压转换器
- 输出电平高达电源 V_{CC} CMOS 电平
 - 1.8V 至 3.3V ($V_{CC}=3.3V$ 时)
 - 2.5V 至 3.3V ($V_{CC}=3.3V$ 时)
 - 1.8V 至 2.5V ($V_{CC}=2.5V$ 时)
 - 3.3V 至 2.5V ($V_{CC}=2.5V$ 时)
- 施密特触发器输入可抑制输入噪声并提供更佳的输出信号完整性
- $I_{关闭}$ 支持部分断电 ($V_{CC}=0$)
- 超低静态功耗：
0.1 μ A
- 超低动态功耗：
0.9 μ A
- 闩锁性能超过 100mA，符合 JESD 78 II 类规范的要求
- 可提供无铅封装：SC70 (DCK)
2 x 2.1 x 0.65mm (高 1.1mm)
- 有关更多逻辑门选项，请访问 www.ti.com/littlelogic

2 说明

SN74AUP1T08 执行布尔函数 $Y = A \cdot B$ or $Y = \overline{A + B}$ ，专门用于逻辑电平转换应用，在此类应用中输出以电源 V_{CC} 为基准。

AUP 技术是行业最低功耗逻辑技术，此技术设计用于扩展运行中的电池寿命。所有接受 1.8V LVCMOS 信号的输入电平，同时由一个单 3.3V 或 2.5V V_{CC} 电源供电运行。该产品还可以保持出色的信号完整性（请见图 5-1 和图 5-2）。

2.3V 至 3.6V 的宽 V_{CC} 范围有可能实现开关输出电平连接至外部控制器或处理器。

施密特触发器输入（正负输入转换之间的 $\Delta V_T=210mV$ ）改进了开关转换期间的抗扰度，这对于模拟混合模式设计十分有用。施密特触发器输入抑制输入噪声、确保输出信号的完整性并可实现慢输入信号转换。

$I_{关闭}$ 特性可实现省电条件 ($V_{CC}=0V$)，这在便携式和移动应用中十分重要。当 $V_{CC}=0V$ 时，介于 0V 至 3.6V 范围内的信号可被施加到器件的输入和输出上。在这些条件下，不会对器件造成损坏。

SN74AUP1T08 经设计优化具有 4mA 电流驱动能力，可减少由高驱动输出导致的线路反射、过冲和下冲。

器件信息

器件型号	封装 ⁽¹⁾	封装尺寸 (标称值)
SN74AUP1T08	SC70 (5)	2mm x 1.25mm

(1) 如需了解所有可用封装，请参阅数据表末尾的可订购产品附录。



逻辑图 (与门)



Table of Contents

1 特性	1	5.10 Operating Characteristics.....	7
2 说明	1	5.11 Typical Characteristics.....	7
3 Revision History	2	6 Parameter Measurement Information	8
4 Pin Configuration and Functions	3	7 Detailed Description	10
5 Specifications	4	7.1 Functional Block Diagram.....	10
5.1 Absolute Maximum Ratings.....	4	7.2 Device Functional Modes.....	10
5.2 Recommended Operating Conditions.....	4	8 Device and Documentation Support	11
5.3 Electrical Characteristics.....	4	8.1 Documentation Support.....	11
5.4 Switching Characteristics.....	5	8.2 Receiving Notification of Documentation Updates....	11
5.5 Switching Characteristics.....	6	8.3 Support Resources.....	11
5.6 Switching Characteristics.....	6	8.4 Trademarks.....	11
5.7 Switching Characteristics.....	6	8.5 Glossary.....	11
5.8 Switching Characteristics.....	6	9 Mechanical, Packaging, and Orderable Information..	11
5.9 Switching Characteristics.....	7		

3 Revision History

注：以前版本的页码可能与当前版本的页码不同

Changes from Revision * (April 2010) to Revision A (September 2020)	Page
• 添加了器件信息表、器件功能模式、器件和文档支持部分以及机械、封装和可订购信息部分.....	1
• 更新了整个文档的表、图和交叉参考的编号格式.....	1

4 Pin Configuration and Functions



图 4-1. DCK Package 5-Pin SC70 Top View

5 Specifications

5.1 Absolute Maximum Ratings

over operating free-air temperature range (unless otherwise noted)⁽¹⁾

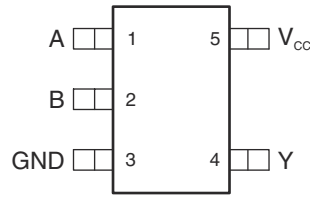
		MIN	MAX	UNIT
V _{CC}	Supply voltage range	- 0.5	4.6	V
V _I	Input voltage range ⁽²⁾	- 0.5	4.6	V
V _O	Voltage range applied to any output in the high-impedance or power-off state ⁽²⁾	- 0.5	4.6	V
V _O	Output voltage range in the high or low state ⁽²⁾	- 0.5	V _{CC} + 0.5	V
I _{IK}	Input clamp current	V _I < 0		- 50 mA
I _{OK}	Output clamp current	V _O < 0		- 50 mA
I _O	Continuous output current			±20 mA
	Continuous current through V _{CC} or GND			±50 mA
θ _{JA}	Package thermal impedance ⁽³⁾	DCK package		259 °C/W
T _{stg}	Storage temperature	- 65	150	°C

- (1) Stresses beyond those listed under "absolute maximum ratings" may cause permanent damage to the device. These are stress ratings only, and functional operation of the device at these or any other conditions beyond those indicated under "recommended operating conditions" is not implied. Exposure to absolute-maximum-rated conditions for extended periods may affect device reliability.
- (2) The input negative-voltage and output voltage ratings may be exceeded if the input and output current ratings are observed.
- (3) The package thermal impedance is calculated in accordance with JESD 51-7.

5.2 Recommended Operating Conditions

See⁽¹⁾

		MIN	MAX	UNIT
V _{CC}	Supply voltage	2.3	3.6	V
V _I	Input voltage	0	3.6	V
V _O	Output voltage	0	V _{CC}	V
I _{OH}	High-level output current	V _{CC} = 2.3 V		- 3.1 mA
		V _{CC} = 3 V		- 4
I _{OL}	Low-level output current	V _{CC} = 2.3 V		3.1 mA
		V _{CC} = 3 V		4
T _A	Operating free-air temperature	- 40	85	°C

- (1) All unused inputs of the device must be held at V_{CC} or GND to ensure proper device operation. See [Implications of Slow or Floating CMOS Inputs](#), SCBA004.

5.3 Electrical Characteristics

over recommended operating free-air temperature range (unless otherwise noted)

PARAMETER	TEST CONDITIONS	V _{CC}	T _A = 25°C			T _A = - 40°C to 85°C		UNIT
			MIN	TYP	MAX	MIN	MAX	
V _{T+} Positive-going input threshold voltage		2.3 V to 2.7 V	0.6		1.1	0.6	1.1	V
		3 V to 3.6 V	0.75		1.16	0.75	1.19	
V _{T-} Negative-going input threshold voltage		2.3 V to 2.7 V	0.35		0.6	0.35	0.6	V
		3 V to 3.6 V	0.5		0.85	0.5	0.85	
ΔV _T Hysteresis (V _{T+} - V _{T-})		2.3 V to 2.7 V	0.23		0.6	0.1	0.6	V
		3 V to 3.6 V	0.25		0.56	0.15	0.56	
V _{OH}	I _{OH} = - 20 μA	2.3 V to 3.6 V	V _{CC} - 0.1		V _{CC} - 0.1		V	

5.3 Electrical Characteristics (continued)

over recommended operating free-air temperature range (unless otherwise noted)

PARAMETER	TEST CONDITIONS	V _{CC}	T _A = 25°C			T _A = -40°C to 85°C		UNIT	
			MIN	TYP	MAX	MIN	MAX		
	I _{OH} = -2.3 mA	2.3 V	2.05			1.97			
	I _{OH} = -3.1 mA		1.9			1.85			
	I _{OH} = -2.7 mA	3 V	2.72			2.67			
	I _{OH} = -4 mA		2.6			2.55			
V _{OL}	I _{OL} = 20 μA	2.3 V to 3.6 V				0.1	0.1	V	
	I _{OL} = 2.3 mA	2.3 V				0.31	0.33		
	I _{OL} = 3.1 mA					0.44	0.45		
	I _{OL} = 2.7 mA	3 V				0.31	0.33		
	I _{OL} = 4 mA					0.44	0.45		
I _I	All inputs V _I = 3.6 V or GND	0 V to 3.6 V				0.1	0.5	μA	
I _{off}	V _I or V _O = 0 V to 3.6 V	0 V				0.1	0.5	μA	
Δ I _{off}	V _I or V _O = 3.6 V	0 V to 0.2 V				0.2	0.5	μA	
I _{CC}	V _I = 3.6 V or GND, I _O = 0	2.3 V to 3.6 V				0.5	0.9	μA	
Δ I _{CC}	One input at 0.3 V or 1.1 V, Other inputs at 0 or V _{CC} , I _O = 0	2.3 V to 2.7 V						4	μA
	One input at 0.45 V or 1.2 V, Other inputs at 0 or V _{CC} , I _O = 0	3 V to 3.6 V						12	
C _i	V _I = V _{CC} or GND	3.3 V	1.5					pF	
C _o	V _O = V _{CC} or GND	3.3 V	3					pF	

5.4 Switching Characteristics

over recommended operating free-air temperature range, V_{CC} = 2.5 V ± 0.2 V, V_I = 1.8 V ± 0.15 V (unless otherwise noted) (see [Figure 6-1](#))

PARAMETER	FROM (INPUT)	TO (OUTPUT)	C _L	T _A = 25°C			T _A = -40°C to 85°C		UNIT
				MIN	TYP	MAX	MIN	MAX	
t _{pd}	A or B	Y	5 pF	1.8	2.3	2.9	0.5	6.8	ns
			10 pF	2.3	2.8	3.4	1	7.9	
			15 pF	2.6	3.1	3.8	1	8.7	
			30 pF	3.8	4.4	5.1	1.5	10.8	

5.5 Switching Characteristics

over recommended operating free-air temperature range, $V_{CC} = 2.5\text{ V} \pm 0.2\text{ V}$, $V_I = 2.5\text{ V} \pm 0.2\text{ V}$ (unless otherwise noted) (see [Figure 6-1](#))

PARAMETER	FROM (INPUT)	TO (OUTPUT)	C_L	$T_A = 25^\circ\text{C}$			$T_A = -40^\circ\text{C}$ to 85°C		UNIT
				MIN	TYP	MAX	MIN	MAX	
t_{pd}	A or B	Y	5 pF	1.8	2.3	3.1	0.5	6	ns
			10 pF	2.2	2.8	3.5	1	7.1	
			15 pF	2.6	3.2	5.2	1	7.9	
			30 pF	3.7	4.4	5.2	1.5	10	

5.6 Switching Characteristics

over recommended operating free-air temperature range, $V_{CC} = 2.5\text{ V} \pm 0.2\text{ V}$, $V_I = 3.3\text{ V} \pm 0.3\text{ V}$ (unless otherwise noted) (see [Figure 6-1](#))

PARAMETER	FROM (INPUT)	TO (OUTPUT)	C_L	$T_A = 25^\circ\text{C}$			$T_A = -40^\circ\text{C}$ to 85°C		UNIT
				MIN	TYP	MAX	MIN	MAX	
t_{pd}	A or B	Y	5 pF	2	2.7	3.5	0.5	5.5	ns
			10 pF	2.4	3.1	3.9	1	6.5	
			15 pF	2.8	3.5	4.3	1	7.4	
			30 pF	4	4.7	5.5	1.5	9.5	

5.7 Switching Characteristics

over recommended operating free-air temperature range, $V_{CC} = 3.3\text{ V} \pm 0.3\text{ V}$, $V_I = 1.8\text{ V} \pm 0.15\text{ V}$ (unless otherwise noted) (see [Figure 6-1](#))

PARAMETER	FROM (INPUT)	TO (OUTPUT)	C_L	$T_A = 25^\circ\text{C}$			$T_A = -40^\circ\text{C}$ to 85°C		UNIT
				MIN	TYP	MAX	MIN	MAX	
t_{pd}	A or B	Y	5 pF	1.6	2	2.5	0.5	8	ns
			10 pF	2	2.4	2.9	1	8.5	
			15 pF	2.3	2.8	3.3	1	9.1	
			30 pF	3.4	3.9	4.4	1.5	9.8	

5.8 Switching Characteristics

over recommended operating free-air temperature range, $V_{CC} = 3.3\text{ V} \pm 0.3\text{ V}$, $V_I = 2.5\text{ V} \pm 0.2\text{ V}$ (unless otherwise noted) (see [Figure 6-1](#))

PARAMETER	FROM (INPUT)	TO (OUTPUT)	C_L	$T_A = 25^\circ\text{C}$			$T_A = -40^\circ\text{C}$ to 85°C		UNIT
				MIN	TYP	MAX	MIN	MAX	
t_{pd}	A or B	Y	5 pF	1.6	1.9	2.4	0.5	5.3	ns
			10 pF	2	2.3	2.7	1	6.1	
			15 pF	2.3	2.7	3.1	1	6.8	
			30 pF	3.4	3.8	4.2	1.5	8.5	

5.9 Switching Characteristics

over recommended operating free-air temperature range, $V_{CC} = 3.3\text{ V} \pm 0.3\text{ V}$, $V_I = 3.3\text{ V} \pm 0.3\text{ V}$ (unless otherwise noted) (see 图 6-1)

PARAMETER	FROM (INPUT)	TO (OUTPUT)	C_L	$T_A = 25^\circ\text{C}$			$T_A = -40^\circ\text{C}$ to 85°C		UNIT
				MIN	TYP	MAX	MIN	MAX	
t_{pd}	A or B	Y	5 pF	1.6	2.1	2.7	0.5	4.7	ns
			10 pF	2	2.4	3	1	5.7	
			15 pF	2.3	2.7	3.3	1	6.2	
			30 pF	3.4	3.8	4.4	1.5	7.8	

5.10 Operating Characteristics

$T_A = 25^\circ\text{C}$

PARAMETER	TEST CONDITIONS	$V_{CC} = 2.5\text{ V}$	$V_{CC} = 3.3\text{ V}$	UNIT
		TYP	TYP	
C_{pd} Power dissipation capacitance	$f = 10\text{ MHz}$	4	5	pF

5.11 Typical Characteristics

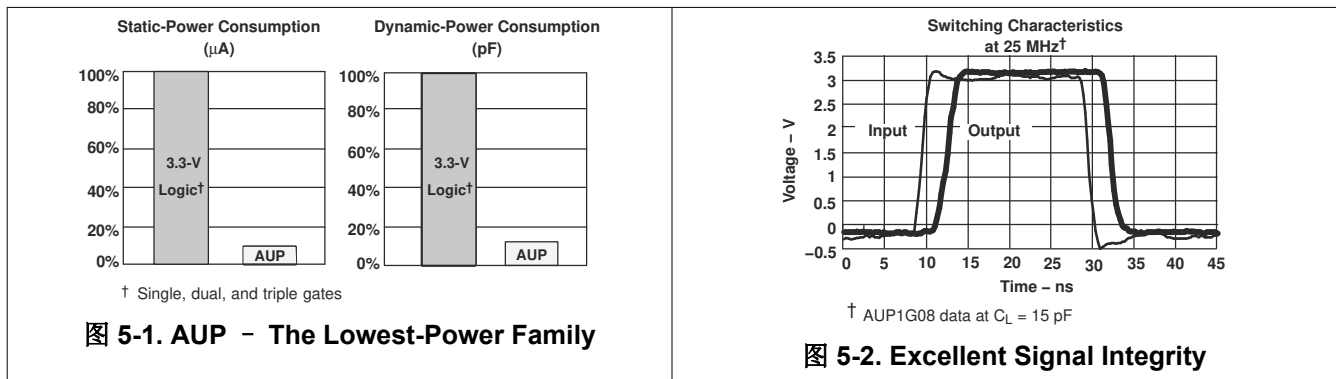

6 Parameter Measurement Information

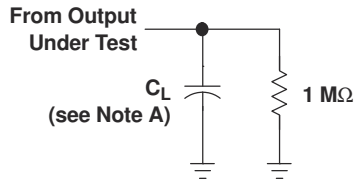

LOAD CIRCUIT

	$V_{CC} = 2.5\text{ V}$ $\pm 0.2\text{ V}$	$V_{CC} = 3.3\text{ V}$ $\pm 0.3\text{ V}$
C_L	5, 10, 15, 30 pF	5, 10, 15, 30 pF
V_{MI}	$V_I/2$	$V_I/2$
V_{MO}	$V_{CC}/2$	$V_{CC}/2$

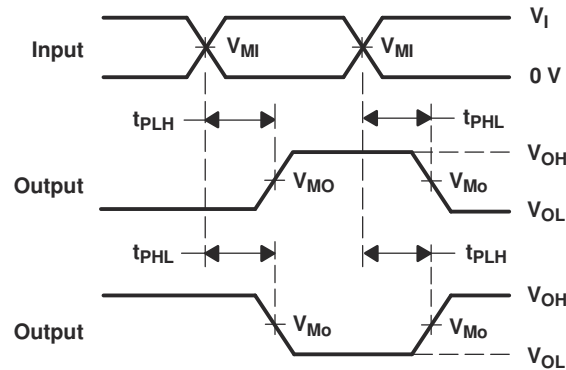

VOLTAGE WAVEFORMS
PROPAGATION DELAY TIMES
INVERTING AND NONINVERTING OUTPUTS

- NOTES: A. C_L includes probe and jig capacitance.
 B. All input pulses are supplied by generators having the following characteristics: PRR \leq 10 MHz, $Z_O = 50\ \Omega$, slew rate \geq 1 V/ns.
 C. The outputs are measured one at a time, with one transition per measurement.
 D. t_{PLH} and t_{PHL} are the same as t_{pd} .

图 6-1. Load Circuit And Voltage Waveforms



图 6-2. Typical Design Examples



图 6-3. Switching Thresholds For 1.8-V To 3.3-V Translation

7 Detailed Description

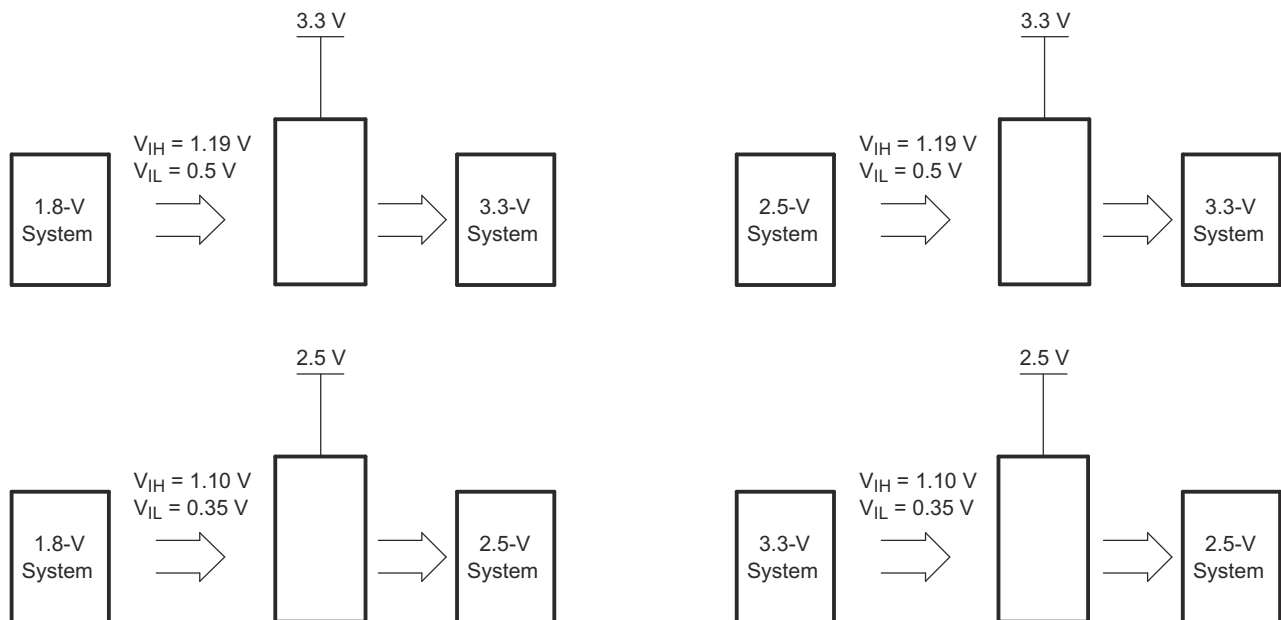
7.1 Functional Block Diagram

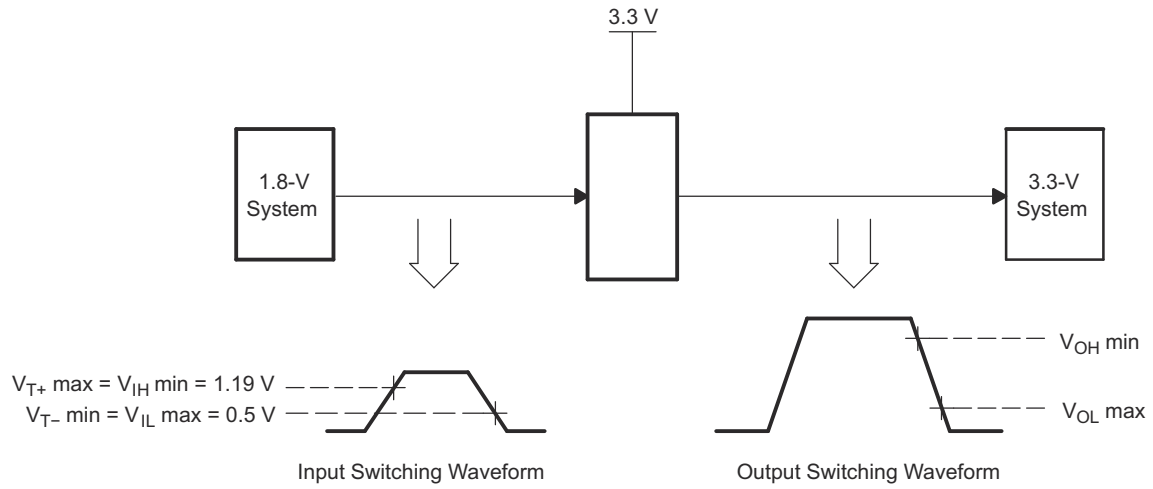

图 7-1. Logic Diagram (AND Gate)

7.2 Device Functional Modes

表 7-1 through 表 7-3 list the functional modes of the SN74AUP1T08 device.

Table 7-1. Function Table

INPUTS (Lower Level Input)		OUTPUT (V _{CC} CMOS)
A	B	Y
H	H	H
L	X	L
X	L	L

Table 7-2. Supply V_{CC} = 2.3 V To 2.7 V (2.5 V)

INPUTS V _{T+} max = V _{IH} min V _{T-} min = V _{IL} max		OUTPUT CMOS
A	B	Y
V _{IH} = 1.1 V V _{IL} = 0.35 V		V _{OH} = 1.85 V V _{OL} = 0.45 V

Table 7-3. Supply V_{CC} = 3 V To 3.6 V (3.3 V)

INPUTS V _{T+} max = V _{IH} min V _{T-} min = V _{IL} max		OUTPUT CMOS
A	B	Y
V _{IH} = 1.19 V V _{IL} = 0.5 V		V _{OH} = 2.55 V V _{OL} = 0.45 V

8 Device and Documentation Support

8.1 Documentation Support

8.1.1 Related Documentation

For related documentation see the following:

[Implications of Slow or Floating CMOS Inputs](#), SCBA004

8.2 Receiving Notification of Documentation Updates

To receive notification of documentation updates, navigate to the device product folder on [ti.com](#). Click on *Subscribe to updates* to register and receive a weekly digest of any product information that has changed. For change details, review the revision history included in any revised document.

8.3 Support Resources

[TI E2E™ support forums](#) are an engineer's go-to source for fast, verified answers and design help — straight from the experts. Search existing answers or ask your own question to get the quick design help you need.

Linked content is provided "AS IS" by the respective contributors. They do not constitute TI specifications and do not necessarily reflect TI's views; see TI's [Terms of Use](#).

8.4 Trademarks

TI E2E™ is a trademark of Texas Instruments.

所有商标均为其各自所有者的财产。

8.5 Glossary

[TI Glossary](#) This glossary lists and explains terms, acronyms, and definitions.

9 Mechanical, Packaging, and Orderable Information

The following pages include mechanical, packaging, and orderable information. This information is the most current data available for the designated devices. This data is subject to change without notice and revision of this document. For browser-based versions of this data sheet, refer to the left-hand navigation.

PACKAGING INFORMATION

Orderable Device	Status (1)	Package Type	Package Drawing	Pins	Package Qty	Eco Plan (2)	Lead finish/ Ball material (6)	MSL Peak Temp (3)	Op Temp (°C)	Device Marking (4/5)	Samples
SN74AUP1T08DCKR	ACTIVE	SC70	DCK	5	3000	RoHS & Green	NIPDAU SN	Level-1-260C-UNLIM	-40 to 85	6EF	Samples

(1) The marketing status values are defined as follows:

ACTIVE: Product device recommended for new designs.

LIFEBUY: TI has announced that the device will be discontinued, and a lifetime-buy period is in effect.

NRND: Not recommended for new designs. Device is in production to support existing customers, but TI does not recommend using this part in a new design.

PREVIEW: Device has been announced but is not in production. Samples may or may not be available.

OBSELETE: TI has discontinued the production of the device.

(2) **RoHS:** TI defines "RoHS" to mean semiconductor products that are compliant with the current EU RoHS requirements for all 10 RoHS substances, including the requirement that RoHS substance do not exceed 0.1% by weight in homogeneous materials. Where designed to be soldered at high temperatures, "RoHS" products are suitable for use in specified lead-free processes. TI may reference these types of products as "Pb-Free".

RoHS Exempt: TI defines "RoHS Exempt" to mean products that contain lead but are compliant with EU RoHS pursuant to a specific EU RoHS exemption.

Green: TI defines "Green" to mean the content of Chlorine (Cl) and Bromine (Br) based flame retardants meet JS709B low halogen requirements of <=1000ppm threshold. Antimony trioxide based flame retardants must also meet the <=1000ppm threshold requirement.

(3) MSL, Peak Temp. - The Moisture Sensitivity Level rating according to the JEDEC industry standard classifications, and peak solder temperature.

(4) There may be additional marking, which relates to the logo, the lot trace code information, or the environmental category on the device.

(5) Multiple Device Markings will be inside parentheses. Only one Device Marking contained in parentheses and separated by a "~" will appear on a device. If a line is indented then it is a continuation of the previous line and the two combined represent the entire Device Marking for that device.

(6) Lead finish/Ball material - Orderable Devices may have multiple material finish options. Finish options are separated by a vertical ruled line. Lead finish/Ball material values may wrap to two lines if the finish value exceeds the maximum column width.

Important Information and Disclaimer:The information provided on this page represents TI's knowledge and belief as of the date that it is provided. TI bases its knowledge and belief on information provided by third parties, and makes no representation or warranty as to the accuracy of such information. Efforts are underway to better integrate information from third parties. TI has taken and continues to take reasonable steps to provide representative and accurate information but may not have conducted destructive testing or chemical analysis on incoming materials and chemicals. TI and TI suppliers consider certain information to be proprietary, and thus CAS numbers and other limited information may not be available for release.

In no event shall TI's liability arising out of such information exceed the total purchase price of the TI part(s) at issue in this document sold by TI to Customer on an annual basis.

TAPE AND REEL INFORMATION

QUADRANT ASSIGNMENTS FOR PIN 1 ORIENTATION IN TAPE

*All dimensions are nominal

Device	Package Type	Package Drawing	Pins	SPQ	Reel Diameter (mm)	Reel Width W1 (mm)	A0 (mm)	B0 (mm)	K0 (mm)	P1 (mm)	W (mm)	Pin1 Quadrant
SN74AUP1T08DCKR	SC70	DCK	5	3000	178.0	9.0	2.4	2.5	1.2	4.0	8.0	Q3

TAPE AND REEL BOX DIMENSIONS

*All dimensions are nominal

Device	Package Type	Package Drawing	Pins	SPQ	Length (mm)	Width (mm)	Height (mm)
SN74AUP1T08DCKR	SC70	DCK	5	3000	180.0	180.0	18.0

DCK0005A



PACKAGE OUTLINE

SOT - 1.1 max height

SMALL OUTLINE TRANSISTOR

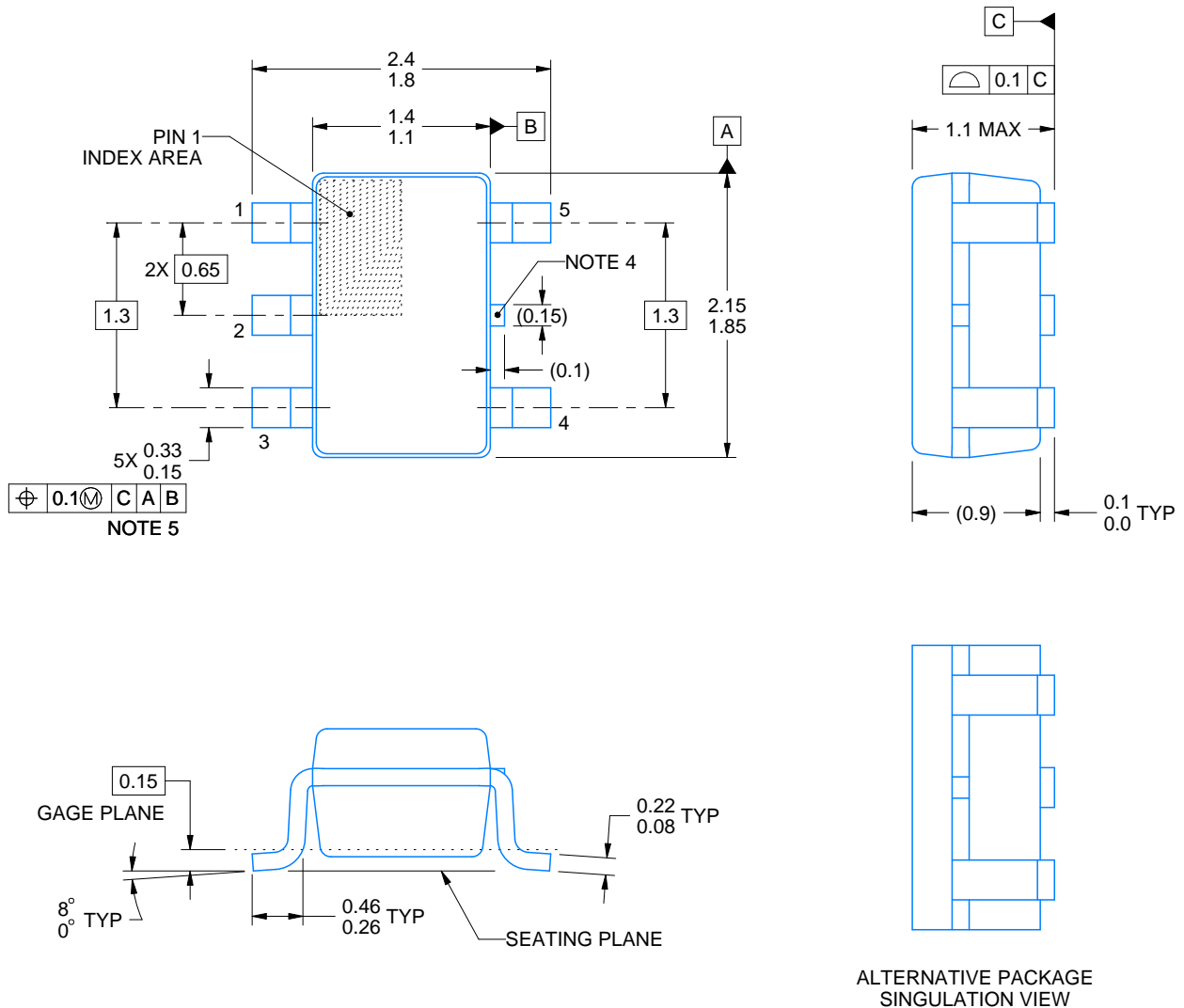

4214834/E 06/2024

NOTES:

1. All linear dimensions are in millimeters. Any dimensions in parenthesis are for reference only. Dimensioning and tolerancing per ASME Y14.5M.
2. This drawing is subject to change without notice.
3. Reference JEDEC MO-203.
4. Support pin may differ or may not be present.
5. Lead width does not comply with JEDEC.
6. Body dimensions do not include mold flash, protrusions, or gate burrs. Mold flash, protrusions, or gate burrs shall not exceed 0.25mm per side

EXAMPLE BOARD LAYOUT

DCK0005A

SOT - 1.1 max height

SMALL OUTLINE TRANSISTOR



LAND PATTERN EXAMPLE
EXPOSED METAL SHOWN
SCALE:18X



SOLDER MASK DETAILS

4214834/E 06/2024

NOTES: (continued)

- 7. Publication IPC-7351 may have alternate designs.
- 8. Solder mask tolerances between and around signal pads can vary based on board fabrication site.

EXAMPLE STENCIL DESIGN

DCK0005A

SOT - 1.1 max height

SMALL OUTLINE TRANSISTOR



SOLDER PASTE EXAMPLE
BASED ON 0.125 THICK STENCIL
SCALE: 18X

4214834/E 06/2024

NOTES: (continued)

9. Laser cutting apertures with trapezoidal walls and rounded corners may offer better paste release. IPC-7525 may have alternate design recommendations.
10. Board assembly site may have different recommendations for stencil design.

重要声明和免责声明

TI“按原样”提供技术和可靠性数据（包括数据表）、设计资源（包括参考设计）、应用或其他设计建议、网络工具、安全信息和其他资源，不保证没有瑕疵且不做任何明示或暗示的担保，包括但不限于对适销性、某特定用途方面的适用性或不侵犯任何第三方知识产权的暗示担保。

这些资源可供使用 TI 产品进行设计的熟练开发人员使用。您将自行承担以下全部责任：(1) 针对您的应用选择合适的 TI 产品，(2) 设计、验证并测试您的应用，(3) 确保您的应用满足相应标准以及任何其他功能安全、信息安全、监管或其他要求。

这些资源如有变更，恕不另行通知。TI 授权您仅可将这些资源用于研发本资源所述的 TI 产品的应用。严禁对这些资源进行其他复制或展示。您无权使用任何其他 TI 知识产权或任何第三方知识产权。您应全额赔偿因在这些资源的使用中对 TI 及其代表造成的任何索赔、损害、成本、损失和债务，TI 对此概不负责。

TI 提供的产品受 [TI 的销售条款](#) 或 [ti.com](#) 上其他适用条款/TI 产品随附的其他适用条款的约束。TI 提供这些资源并不会扩展或以其他方式更改 TI 针对 TI 产品发布的适用的担保或担保免责声明。

TI 反对并拒绝您可能提出的任何其他或不同的条款。

邮寄地址：Texas Instruments, Post Office Box 655303, Dallas, Texas 75265

Copyright © 2024，德州仪器 (TI) 公司