

SN5404, SN54LS04, SN54S04, SN7404, SN74LS04, SN74S04 HEX INVERTERS

SDLS029C – DECEMBER 1983 – REVISED JANUARY 2004

- Dependable Texas Instruments Quality and Reliability

description/ordering information

These devices contain six independent inverters.

SN5404 . . . J PACKAGE
SN54LS04, SN54S04 . . . J OR W PACKAGE
SN7404, SN74S04 . . . D, N, OR NS PACKAGE
SN74LS04 . . . D, DB, N, OR NS PACKAGE

(TOP VIEW)



SN5404 . . . W PACKAGE

(TOP VIEW)

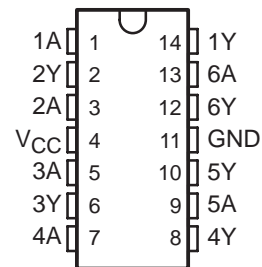

SN54LS04, SN54S04 . . . FK PACKAGE

(TOP VIEW)

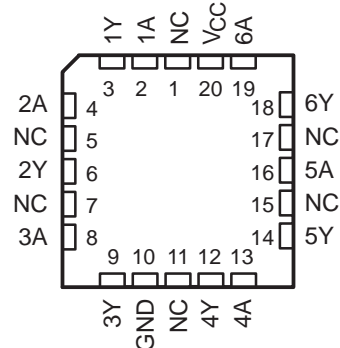

NC – No internal connection



Please be aware that an important notice concerning availability, standard warranty, and use in critical applications of Texas Instruments semiconductor products and disclaimers thereto appears at the end of this data sheet.

PRODUCTION DATA information is current as of publication date. Products conform to specifications per the terms of Texas Instruments standard warranty. Production processing does not necessarily include testing of all parameters.

 **TEXAS
INSTRUMENTS**

POST OFFICE BOX 655303 • DALLAS, TEXAS 75265

Copyright © 2004, Texas Instruments Incorporated
On products compliant to MIL-PRF-38535, all parameters are tested unless otherwise noted. On all other products, production processing does not necessarily include testing of all parameters.

**SN5404, SN54LS04, SN54S04,
SN7404, SN74LS04, SN74S04
HEX INVERTERS**

SDLS029C – DECEMBER 1983 – REVISED JANUARY 2004

ORDERING INFORMATION

T_A	PACKAGE†		ORDERABLE PART NUMBER	TOP-SIDE MARKING
0°C to 70°C	PDIP – N	Tube	SN7404N	SN7404N
		Tube	SN74LS04N	SN74LS04N
		Tube	SN74S04N	SN74S04N
	SOIC – D	Tube	SN7404D	7404
		Tape and reel	SN7404DR	
		Tube	SN74LS04D	LS04
		Tape and reel	SN74LS04DR	
		Tube	SN74S04D	S04
		Tape and reel	SN74S04DR	
	SOP – NS	Tape and reel	SN7404NSR	SN7404
		Tape and reel	SN74LS04NSR	74LS04
		Tape and reel	SN74S04NSR	74S04
	SSOP – DB	Tape and reel	SN74LS04DBR	LS04
	–55°C to 125°C	CDIP – J	Tube	SN5404J
Tube			SNJ5404J	SNJ5404J
Tube			SN54LS04J	SN54LS04J
Tube			SN54S04J	SN54S04J
Tube			SNJ54LS04J	SNJ54LS04J
Tube			SNJ54S04J	SNJ54S04J
CFP – W		Tube	SNJ5404W	SNJ5404W
		Tube	SNJ54LS04W	SNJ54LS04W
		Tube	SNJ54S04W	SNJ54S04W
LCCC – FK		Tube	SNJ54LS04FK	SNJ54LS04FK
		Tube	SNJ54S04FK	SNJ54S04FK

† Package drawings, standard packing quantities, thermal data, symbolization, and PCB design guidelines are available at www.ti.com/sc/package.

**FUNCTION TABLE
(each inverter)**

INPUT A	OUTPUT Y
H	L
L	H



**SN5404, SN54LS04, SN54S04,
SN7404, SN74LS04, SN74S04
HEX INVERTERS**

SDLS029C – DECEMBER 1983 – REVISED JANUARY 2004

logic diagram (positive logic)



$$Y = \bar{A}$$

SN5404, SN54LS04, SN54S04, SN7404, SN74LS04, SN74S04 HEX INVERTERS

SDLS029C – DECEMBER 1983 – REVISED JANUARY 2004

schematics (each gate)



Resistor values shown are nominal.

SN5404, SN54LS04, SN54S04, SN7404, SN74LS04, SN74S04 HEX INVERTERS

SDLS029C – DECEMBER 1983 – REVISED JANUARY 2004

absolute maximum ratings over operating free-air temperature range (unless otherwise noted)†

Supply voltage, V_{CC} (see Note 1)	7 V
Input voltage, V_I : '04, 'S04	5.5 V
'LS04	7 V
Package thermal impedance, θ_{JA} (see Note 2): D package	86°C/W
DB package	96°C/W
N package	80°C/W
NS package	76°C/W
Storage temperature range, T_{stg}	-65°C to 150°C

† Stresses beyond those listed under “absolute maximum ratings” may cause permanent damage to the device. This are stress ratings only, and functional operation of the device at these or any other conditions beyond those indicated under “recommended operating conditions” is not implied. Exposure to absolute-maximum-rated conditions for extended periods may affect device reliability.

- NOTES: 1. Voltage values are with respect to network ground terminal.
2. The package thermal impedance is calculated in accordance with JESD 51-7.

recommended operating conditions (see Note 3)

		SN5404			SN7404			UNIT
		MIN	NOM	MAX	MIN	NOM	MAX	
V_{CC}	Supply voltage	4.5	5	5.5	4.75	5	5.25	V
V_{IH}	High-level input voltage	2			2			V
V_{IL}	Low-level input voltage	0.8			0.8			V
I_{OH}	High-level output current	-0.4			-0.4			mA
I_{OL}	Low-level output current	16			16			mA
T_A	Operating free-air temperature	-55	125		0	70		°C

NOTE 3: All unused inputs of the device must be held at V_{CC} or GND to ensure proper device operation. Refer to the TI application report, *Implications of Slow or Floating CMOS Inputs*, literature number SCBA004.

electrical characteristics over recommended operating free-air temperature range (unless otherwise noted)

PARAMETER	TEST CONDITIONS‡	SN5404			SN7404			UNIT
		MIN	TYP§	MAX	MIN	TYP§	MAX	
V_{IK}	$V_{CC} = \text{MIN}$, $I_I = -12 \text{ mA}$	-1.5			-1.5			V
V_{OH}	$V_{CC} = \text{MIN}$, $V_{IL} = 0.8 \text{ V}$, $I_{OH} = -0.4 \text{ mA}$	2.4	3.4		2.4	3.4	V	
V_{OL}	$V_{CC} = \text{MIN}$, $V_{IH} = 2 \text{ V}$, $I_{OL} = 16 \text{ mA}$	0.2 0.4			0.2 0.4			V
I_I	$V_{CC} = \text{MAX}$, $V_I = 5.5 \text{ V}$	1			1			mA
I_{IH}	$V_{CC} = \text{MAX}$, $V_I = 2.4 \text{ V}$	40			40			µA
I_{IL}	$V_{CC} = \text{MAX}$, $V_I = 0.4 \text{ V}$	-1.6			-1.6			mA
I_{OS}^{\parallel}	$V_{CC} = \text{MAX}$	-20	-55		-18	-55		mA
I_{CCH}	$V_{CC} = \text{MAX}$, $V_I = 0 \text{ V}$	6 12			6 12			mA
I_{CCL}	$V_{CC} = \text{MAX}$, $V_I = 4.5 \text{ V}$	18 33			18 33			mA

‡ For conditions shown as MIN or MAX, use the appropriate value specified under recommended operating conditions.

§ All typical values are at $V_{CC} = 5 \text{ V}$, $T_A = 25^\circ\text{C}$.

¶ Not more than one output should be shorted at a time.



SN5404, SN54LS04, SN54S04, SN7404, SN74LS04, SN74S04 HEX INVERTERS

SDLS029C – DECEMBER 1983 – REVISED JANUARY 2004

switching characteristics, $V_{CC} = 5\text{ V}$, $T_A = 25^\circ\text{C}$ (see Figure 1)

PARAMETER	FROM (INPUT)	TO (OUTPUT)	TEST CONDITIONS	SN5404 SN7404			UNIT
				MIN	TYP	MAX	
t_{PLH}	A	Y	$R_L = 400\ \Omega$, $C_L = 15\text{ pF}$	12		22	ns
t_{PHL}				8		15	

recommended operating conditions (see Note 3)

		SN54LS04			SN74LS04			UNIT
		MIN	NOM	MAX	MIN	NOM	MAX	
V_{CC}	Supply voltage	4.5	5	5.5	4.75	5	5.25	V
V_{IH}	High-level input voltage	2			2			V
V_{IL}	Low-level input voltage	0.7			0.8			V
I_{OH}	High-level output current	-0.4			-0.4			mA
I_{OL}	Low-level output current	4			8			mA
T_A	Operating free-air temperature	-55	125		0	70		$^\circ\text{C}$

NOTE 3: All unused inputs of the device must be held at V_{CC} or GND to ensure proper device operation. Refer to the TI application report, *Implications of Slow or Floating CMOS Inputs*, literature number SCBA004.

electrical characteristics over recommended operating free-air temperature range (unless otherwise noted)

PARAMETER	TEST CONDITIONS†	SN54LS04			SN74LS04			UNIT
		MIN	TYP‡	MAX	MIN	TYP‡	MAX	
V_{IK}	$V_{CC} = \text{MIN}$, $I_I = -18\text{ mA}$	-1.5			-1.5			V
V_{OH}	$V_{CC} = \text{MIN}$, $V_{IL} = \text{MAX}$, $I_{OH} = -0.4\text{ mA}$	2.5	3.4		2.7	3.4		V
V_{OL}	$V_{CC} = \text{MIN}$, $V_{IH} = 2\text{ V}$	$I_{OL} = 4\text{ mA}$		0.4		0.4		V
		$I_{OL} = 8\text{ mA}$				0.25 0.5		
I_I	$V_{CC} = \text{MAX}$, $V_I = 7\text{ V}$	0.1			0.1			mA
I_{IH}	$V_{CC} = \text{MAX}$, $V_I = 2.7\text{ V}$	20			20			μA
I_{IL}	$V_{CC} = \text{MAX}$, $V_I = 0.4\text{ V}$	-0.4			-0.4			mA
$I_{OS}§$	$V_{CC} = \text{MAX}$	-20	-100		-20	-100		mA
I_{CCH}	$V_{CC} = \text{MAX}$, $V_I = 0\text{ V}$	1.2 2.4		1.2 2.4		1.2 2.4		mA
I_{CCL}	$V_{CC} = \text{MAX}$, $V_I = 4.5\text{ V}$	3.6 6.6		3.6 6.6		3.6 6.6		mA

† For conditions shown as MIN or MAX, use the appropriate value specified under recommended operating conditions.

‡ All typical values are at $V_{CC} = 5\text{ V}$, $T_A = 25^\circ\text{C}$.

§ Not more than one output should be shorted at a time, and the duration of the short-circuit should not exceed one second.

switching characteristics, $V_{CC} = 5\text{ V}$, $T_A = 25^\circ\text{C}$ (see Figure 2)

PARAMETER	FROM (INPUT)	TO (OUTPUT)	TEST CONDITIONS	SN54LS04 SN74LS04			UNIT
				MIN	TYP	MAX	
t_{PLH}	A	Y	$R_L = 2\text{ k}\Omega$, $C_L = 15\text{ pF}$	9		15	ns
t_{PHL}				10		15	



SN5404, SN54LS04, SN54S04, SN7404, SN74LS04, SN74S04 HEX INVERTERS

SDLS029C – DECEMBER 1983 – REVISED JANUARY 2004

recommended operating conditions (see Note 3)

		SN54S04			SN74S04			UNIT
		MIN	NOM	MAX	MIN	NOM	MAX	
V_{CC}	Supply voltage	4.5	5	5.5	4.75	5	5.25	V
V_{IH}	High-level input voltage	2			2			V
V_{IL}	Low-level input voltage			0.8			0.8	V
I_{OH}	High-level output current			-1			-1	mA
I_{OL}	Low-level output current			20			20	mA
T_A	Operating free-air temperature	-55		125	0		70	°C

NOTE 3: All unused inputs of the device must be held at V_{CC} or GND to ensure proper device operation. Refer to the TI application report, *Implications of Slow or Floating CMOS Inputs*, literature number SCBA004.

electrical characteristics over recommended operating free-air temperature range (unless otherwise noted)

PARAMETER	TEST CONDITIONS†	SN54S04			SN74S04			UNIT
		MIN	TYP‡	MAX	MIN	TYP‡	MAX	
V_{IK}	$V_{CC} = \text{MIN}$, $I_I = -18 \text{ mA}$			-1.2			-1.2	V
V_{OH}	$V_{CC} = \text{MIN}$, $V_{IL} = 0.8 \text{ V}$, $I_{OH} = -1 \text{ mA}$	2.5	3.4		2.7	3.4		V
V_{OL}	$V_{CC} = \text{MIN}$, $V_{IH} = 2 \text{ V}$, $I_{OL} = 20 \text{ mA}$			0.5			0.5	V
I_I	$V_{CC} = \text{MAX}$, $V_I = 5.5 \text{ V}$			1			1	mA
I_{IH}	$V_{CC} = \text{MAX}$, $V_I = 2.7 \text{ V}$			50			50	μA
I_{IL}	$V_{CC} = \text{MAX}$, $V_I = 0.5 \text{ V}$			-2			-2	mA
$I_{OS}§$	$V_{CC} = \text{MAX}$	-40		-100	-40		-100	mA
I_{CCH}	$V_{CC} = \text{MAX}$, $V_I = 0 \text{ V}$		15	24		15	24	mA
I_{CCL}	$V_{CC} = \text{MAX}$, $V_I = 4.5 \text{ V}$		30	54		30	54	mA

† For conditions shown as MIN or MAX, use the appropriate value specified under recommended operating conditions.

‡ All typical values are at $V_{CC} = 5 \text{ V}$, $T_A = 25^\circ\text{C}$.

§ Not more than one output should be shorted at a time, and the duration of the short-circuit should not exceed one second.

switching characteristics, $V_{CC} = 5 \text{ V}$, $T_A = 25^\circ\text{C}$ (see Figure 1)

PARAMETER	FROM (INPUT)	TO (OUTPUT)	TEST CONDITIONS	SN54S04 SN74S04			UNIT
				MIN	TYP	MAX	
t_{PLH}	A	Y	$R_L = 280 \Omega$, $C_L = 15 \text{ pF}$	3		4.5	ns
t_{PHL}				3		5	
t_{PLH}	A	Y	$R_L = 280 \Omega$, $C_L = 50 \text{ pF}$	4.5		5	ns
t_{PHL}				5			

**SN5404, SN54LS04, SN54S04,
SN7404, SN74LS04, SN74S04
HEX INVERTERS**

SDLS029C – DECEMBER 1983 – REVISED JANUARY 2004

**PARAMETER MEASUREMENT INFORMATION
SERIES 54/74 AND 54S/74S DEVICES**



- NOTES: A. C_L includes probe and jig capacitance.
 B. All diodes are 1N3064 or equivalent.
 C. Waveform 1 is for an output with internal conditions such that the output is low, except when disabled by the output control. Waveform 2 is for an output with internal conditions such that the output is high, except when disabled by the output control.
 D. S1 and S2 are closed for t_{PLH} , t_{PHL} , t_{PHZ} , and t_{PZL} ; S1 is open and S2 is closed for t_{PZH} ; S1 is closed and S2 is open for t_{PZL} .
 E. All input pulses are supplied by generators having the following characteristics: $PRR \leq 1$ MHz, $Z_O \approx 50 \Omega$; t_r and $t_f \leq 7$ ns for Series 54/74 devices and t_r and $t_f \leq 2.5$ ns for Series 54S/74S devices.
 F. The outputs are measured one at a time, with one input transition per measurement.

Figure 1. Load Circuits and Voltage Waveforms

PARAMETER MEASUREMENT INFORMATION
SERIES 54LS/74LS DEVICES



- NOTES: A. C_L includes probe and jig capacitance.
 B. All diodes are 1N3064 or equivalent.
 C. Waveform 1 is for an output with internal conditions such that the output is low, except when disabled by the output control. Waveform 2 is for an output with internal conditions such that the output is high, except when disabled by the output control.
 D. S1 and S2 are closed for t_{PLH} , t_{PHL} , t_{PHZ} , and t_{PLZ} ; S1 is open and S2 is closed for t_{PZH} ; S1 is closed and S2 is open for t_{PZL} .
 E. Phase relationships between inputs and outputs have been chosen arbitrarily for these examples.
 F. All input pulses are supplied by generators having the following characteristics: PRR \leq 1 MHz, $Z_O \approx 50 \Omega$, $t_r \leq 1.5$ ns, $t_f \leq 2.6$ ns.
 G. The outputs are measured one at a time, with one input transition per measurement.

Figure 2. Load Circuits and Voltage Waveforms

PACKAGING INFORMATION

Orderable Device	Status (1)	Package Type	Package Drawing	Pins	Package Qty	Eco Plan (2)	Lead finish/ Ball material (6)	MSL Peak Temp (3)	Op Temp (°C)	Device Marking (4/5)	Samples
JM38510/00105BCA	ACTIVE	CDIP	J	14	25	Non-RoHS & Green	SNPB	N / A for Pkg Type	-55 to 125	JM38510/ 00105BCA	Samples
JM38510/00105BDA	ACTIVE	CFP	W	14	25	Non-RoHS & Green	SNPB	N / A for Pkg Type	-55 to 125	JM38510/ 00105BDA	Samples
JM38510/07003BCA	ACTIVE	CDIP	J	14	25	Non-RoHS & Green	SNPB	N / A for Pkg Type	-55 to 125	JM38510/ 07003BCA	Samples
JM38510/07003BDA	ACTIVE	CFP	W	14	25	Non-RoHS & Green	SNPB	N / A for Pkg Type	-55 to 125	JM38510/ 07003BDA	Samples
JM38510/30003B2A	ACTIVE	LCCC	FK	20	55	Non-RoHS & Green	SNPB	N / A for Pkg Type	-55 to 125	JM38510/ 30003B2A	Samples
JM38510/30003BCA	ACTIVE	CDIP	J	14	25	Non-RoHS & Green	SNPB	N / A for Pkg Type	-55 to 125	JM38510/ 30003BCA	Samples
JM38510/30003BDA	ACTIVE	CFP	W	14	25	Non-RoHS & Green	SNPB	N / A for Pkg Type	-55 to 125	JM38510/ 30003BDA	Samples
JM38510/30003SCA	ACTIVE	CDIP	J	14	25	Non-RoHS & Green	SNPB	N / A for Pkg Type	-55 to 125	JM38510/ 30003SCA	Samples
M38510/00105BCA	ACTIVE	CDIP	J	14	25	Non-RoHS & Green	SNPB	N / A for Pkg Type	-55 to 125	JM38510/ 00105BCA	Samples
M38510/00105BDA	ACTIVE	CFP	W	14	25	Non-RoHS & Green	SNPB	N / A for Pkg Type	-55 to 125	JM38510/ 00105BDA	Samples
M38510/07003BCA	ACTIVE	CDIP	J	14	25	Non-RoHS & Green	SNPB	N / A for Pkg Type	-55 to 125	JM38510/ 07003BCA	Samples
M38510/07003BDA	ACTIVE	CFP	W	14	25	Non-RoHS & Green	SNPB	N / A for Pkg Type	-55 to 125	JM38510/ 07003BDA	Samples
M38510/30003B2A	ACTIVE	LCCC	FK	20	55	Non-RoHS & Green	SNPB	N / A for Pkg Type	-55 to 125	JM38510/ 30003B2A	Samples
M38510/30003BCA	ACTIVE	CDIP	J	14	25	Non-RoHS & Green	SNPB	N / A for Pkg Type	-55 to 125	JM38510/ 30003BCA	Samples
M38510/30003BDA	ACTIVE	CFP	W	14	25	Non-RoHS & Green	SNPB	N / A for Pkg Type	-55 to 125	JM38510/ 30003BDA	Samples
M38510/30003SCA	ACTIVE	CDIP	J	14	25	Non-RoHS & Green	SNPB	N / A for Pkg Type	-55 to 125	JM38510/ 30003SCA	Samples

Orderable Device	Status (1)	Package Type	Package Drawing	Pins	Package Qty	Eco Plan (2)	Lead finish/ Ball material (6)	MSL Peak Temp (3)	Op Temp (°C)	Device Marking (4/5)	Samples
SN5404J	ACTIVE	CDIP	J	14	25	Non-RoHS & Green	SNPB	N / A for Pkg Type	-55 to 125	SN5404J	Samples
SN54LS04J	ACTIVE	CDIP	J	14	25	Non-RoHS & Green	SNPB	N / A for Pkg Type	-55 to 125	SN54LS04J	Samples
SN54S04J	ACTIVE	CDIP	J	14	25	Non-RoHS & Green	SNPB	N / A for Pkg Type	-55 to 125	SN54S04J	Samples
SN7404DR	ACTIVE	SOIC	D	14	2500	RoHS & Green	NIPDAU	Level-1-260C-UNLIM	0 to 70	7404	Samples
SN7404N	ACTIVE	PDIP	N	14	25	RoHS & Green	NIPDAU	N / A for Pkg Type	0 to 70	SN7404N	Samples
SN7404NE4	ACTIVE	PDIP	N	14	25	RoHS & Green	NIPDAU	N / A for Pkg Type	0 to 70	SN7404N	Samples
SN74LS04D	ACTIVE	SOIC	D	14	50	RoHS & Green	NIPDAU	Level-1-260C-UNLIM	0 to 70	LS04	Samples
SN74LS04DBR	ACTIVE	SSOP	DB	14	2000	RoHS & Green	NIPDAU	Level-1-260C-UNLIM		LS04	Samples
SN74LS04DG4	ACTIVE	SOIC	D	14	50	RoHS & Green	NIPDAU	Level-1-260C-UNLIM	0 to 70	LS04	Samples
SN74LS04DR	ACTIVE	SOIC	D	14	2500	RoHS & Green	NIPDAU	Level-1-260C-UNLIM	0 to 70	LS04	Samples
SN74LS04DRG4	ACTIVE	SOIC	D	14	2500	RoHS & Green	NIPDAU	Level-1-260C-UNLIM	0 to 70	LS04	Samples
SN74LS04N	ACTIVE	PDIP	N	14	25	RoHS & Green	NIPDAU	N / A for Pkg Type	0 to 70	SN74LS04N	Samples
SN74LS04NE4	ACTIVE	PDIP	N	14	25	RoHS & Green	NIPDAU	N / A for Pkg Type	0 to 70	SN74LS04N	Samples
SN74LS04NSR	ACTIVE	SO	NS	14	2000	RoHS & Green	NIPDAU	Level-1-260C-UNLIM	0 to 70	74LS04	Samples
SN74S04DR	ACTIVE	SOIC	D	14	2500	RoHS & Green	NIPDAU	Level-1-260C-UNLIM	0 to 70	S04	Samples
SN74S04N	ACTIVE	PDIP	N	14	25	RoHS & Green	NIPDAU	N / A for Pkg Type	0 to 70	SN74S04N	Samples
SN74S04NE4	ACTIVE	PDIP	N	14	25	RoHS & Green	NIPDAU	N / A for Pkg Type	0 to 70	SN74S04N	Samples
SN74S04NSR	ACTIVE	SO	NS	14	2000	RoHS & Green	NIPDAU	Level-1-260C-UNLIM	0 to 70	74S04	Samples
SNJ5404J	ACTIVE	CDIP	J	14	25	Non-RoHS & Green	SNPB	N / A for Pkg Type	-55 to 125	SNJ5404J	Samples
SNJ5404W	ACTIVE	CFP	W	14	25	Non-RoHS & Green	SNPB	N / A for Pkg Type	-55 to 125	SNJ5404W	Samples

Orderable Device	Status (1)	Package Type	Package Drawing	Pins	Package Qty	Eco Plan (2)	Lead finish/ Ball material (6)	MSL Peak Temp (3)	Op Temp (°C)	Device Marking (4/5)	Samples
SNJ54LS04FK	ACTIVE	LCCC	FK	20	55	Non-RoHS & Green	SNPB	N / A for Pkg Type	-55 to 125	SNJ54LS04FK	Samples
SNJ54LS04J	ACTIVE	CDIP	J	14	25	Non-RoHS & Green	SNPB	N / A for Pkg Type	-55 to 125	SNJ54LS04J	Samples
SNJ54LS04W	ACTIVE	CFP	W	14	25	Non-RoHS & Green	SNPB	N / A for Pkg Type	-55 to 125	SNJ54LS04W	Samples
SNJ54S04FK	ACTIVE	LCCC	FK	20	55	Non-RoHS & Green	SNPB	N / A for Pkg Type	-55 to 125	SNJ54S04FK	Samples
SNJ54S04J	ACTIVE	CDIP	J	14	25	Non-RoHS & Green	SNPB	N / A for Pkg Type	-55 to 125	SNJ54S04J	Samples
SNJ54S04W	ACTIVE	CFP	W	14	25	Non-RoHS & Green	SNPB	N / A for Pkg Type	-55 to 125	SNJ54S04W	Samples

(1) The marketing status values are defined as follows:

ACTIVE: Product device recommended for new designs.

LIFEBUY: TI has announced that the device will be discontinued, and a lifetime-buy period is in effect.

NRND: Not recommended for new designs. Device is in production to support existing customers, but TI does not recommend using this part in a new design.

PREVIEW: Device has been announced but is not in production. Samples may or may not be available.

OBsolete: TI has discontinued the production of the device.

(2) **RoHS:** TI defines "RoHS" to mean semiconductor products that are compliant with the current EU RoHS requirements for all 10 RoHS substances, including the requirement that RoHS substance do not exceed 0.1% by weight in homogeneous materials. Where designed to be soldered at high temperatures, "RoHS" products are suitable for use in specified lead-free processes. TI may reference these types of products as "Pb-Free".

RoHS Exempt: TI defines "RoHS Exempt" to mean products that contain lead but are compliant with EU RoHS pursuant to a specific EU RoHS exemption.

Green: TI defines "Green" to mean the content of Chlorine (Cl) and Bromine (Br) based flame retardants meet JS709B low halogen requirements of <=1000ppm threshold. Antimony trioxide based flame retardants must also meet the <=1000ppm threshold requirement.

(3) MSL, Peak Temp. - The Moisture Sensitivity Level rating according to the JEDEC industry standard classifications, and peak solder temperature.

(4) There may be additional marking, which relates to the logo, the lot trace code information, or the environmental category on the device.

(5) Multiple Device Markings will be inside parentheses. Only one Device Marking contained in parentheses and separated by a "~" will appear on a device. If a line is indented then it is a continuation of the previous line and the two combined represent the entire Device Marking for that device.

(6) Lead finish/Ball material - Orderable Devices may have multiple material finish options. Finish options are separated by a vertical ruled line. Lead finish/Ball material values may wrap to two lines if the finish value exceeds the maximum column width.

Important Information and Disclaimer: The information provided on this page represents TI's knowledge and belief as of the date that it is provided. TI bases its knowledge and belief on information provided by third parties, and makes no representation or warranty as to the accuracy of such information. Efforts are underway to better integrate information from third parties. TI has taken and continues to take reasonable steps to provide representative and accurate information but may not have conducted destructive testing or chemical analysis on incoming materials and chemicals. TI and TI suppliers consider certain information to be proprietary, and thus CAS numbers and other limited information may not be available for release.

In no event shall TI's liability arising out of such information exceed the total purchase price of the TI part(s) at issue in this document sold by TI to Customer on an annual basis.

OTHER QUALIFIED VERSIONS OF SN5404, SN54LS04, SN54LS04-SP, SN54S04, SN7404, SN74LS04, SN74S04 :

- Catalog : [SN7404](#), [SN74LS04](#), [SN54LS04](#), [SN74S04](#)
- Military : [SN5404](#), [SN54LS04](#), [SN54S04](#)
- Space : [SN54LS04-SP](#)

NOTE: Qualified Version Definitions:

- Catalog - TI's standard catalog product
- Military - QML certified for Military and Defense Applications
- Space - Radiation tolerant, ceramic packaging and qualified for use in Space-based application

TAPE AND REEL INFORMATION

QUADRANT ASSIGNMENTS FOR PIN 1 ORIENTATION IN TAPE

*All dimensions are nominal

Device	Package Type	Package Drawing	Pins	SPQ	Reel Diameter (mm)	Reel Width W1 (mm)	A0 (mm)	B0 (mm)	K0 (mm)	P1 (mm)	W (mm)	Pin1 Quadrant
SN7404DR	SOIC	D	14	2500	330.0	16.4	6.5	9.0	2.1	8.0	16.0	Q1
SN74LS04DBR	SSOP	DB	14	2000	330.0	16.4	8.35	6.6	2.4	12.0	16.0	Q1
SN74LS04DR	SOIC	D	14	2500	330.0	16.4	6.5	9.0	2.1	8.0	16.0	Q1
SN74LS04NSR	SO	NS	14	2000	330.0	16.4	8.2	10.5	2.5	12.0	16.0	Q1
SN74S04DR	SOIC	D	14	2500	330.0	16.4	6.5	9.0	2.1	8.0	16.0	Q1
SN74S04NSR	SO	NS	14	2000	330.0	16.4	8.2	10.5	2.5	12.0	16.0	Q1

TAPE AND REEL BOX DIMENSIONS

*All dimensions are nominal

Device	Package Type	Package Drawing	Pins	SPQ	Length (mm)	Width (mm)	Height (mm)
SN7404DR	SOIC	D	14	2500	356.0	356.0	35.0
SN74LS04DBR	SSOP	DB	14	2000	356.0	356.0	35.0
SN74LS04DR	SOIC	D	14	2500	356.0	356.0	35.0
SN74LS04NSR	SO	NS	14	2000	356.0	356.0	35.0
SN74S04DR	SOIC	D	14	2500	356.0	356.0	35.0
SN74S04NSR	SO	NS	14	2000	356.0	356.0	35.0

TUBE

*All dimensions are nominal

Device	Package Name	Package Type	Pins	SPQ	L (mm)	W (mm)	T (µm)	B (mm)
JM38510/00105BDA	W	CFP	14	25	506.98	26.16	6220	NA
JM38510/07003BDA	W	CFP	14	25	506.98	26.16	6220	NA
JM38510/30003B2A	FK	LCCC	20	55	506.98	12.06	2030	NA
JM38510/30003BDA	W	CFP	14	25	506.98	26.16	6220	NA
M38510/00105BDA	W	CFP	14	25	506.98	26.16	6220	NA
M38510/07003BDA	W	CFP	14	25	506.98	26.16	6220	NA
M38510/30003B2A	FK	LCCC	20	55	506.98	12.06	2030	NA
M38510/30003BDA	W	CFP	14	25	506.98	26.16	6220	NA
SN7404N	N	PDIP	14	25	506	13.97	11230	4.32
SN7404N	N	PDIP	14	25	506	13.97	11230	4.32
SN7404NE4	N	PDIP	14	25	506	13.97	11230	4.32
SN7404NE4	N	PDIP	14	25	506	13.97	11230	4.32
SN74LS04D	D	SOIC	14	50	506.6	8	3940	4.32
SN74LS04DG4	D	SOIC	14	50	506.6	8	3940	4.32
SN74LS04N	N	PDIP	14	25	506	13.97	11230	4.32
SN74LS04N	N	PDIP	14	25	506	13.97	11230	4.32
SN74LS04NE4	N	PDIP	14	25	506	13.97	11230	4.32
SN74LS04NE4	N	PDIP	14	25	506	13.97	11230	4.32
SN74S04N	N	PDIP	14	25	506	13.97	11230	4.32
SN74S04N	N	PDIP	14	25	506	13.97	11230	4.32
SN74S04NE4	N	PDIP	14	25	506	13.97	11230	4.32
SN74S04NE4	N	PDIP	14	25	506	13.97	11230	4.32
SNJ5404W	W	CFP	14	25	506.98	26.16	6220	NA
SNJ54LS04FK	FK	LCCC	20	55	506.98	12.06	2030	NA
SNJ54LS04W	W	CFP	14	25	506.98	26.16	6220	NA
SNJ54S04FK	FK	LCCC	20	55	506.98	12.06	2030	NA

MECHANICAL DATA

NS (R-PDSO-G**)

PLASTIC SMALL-OUTLINE PACKAGE

14-PINS SHOWN



- NOTES:
- A. All linear dimensions are in millimeters.
 - B. This drawing is subject to change without notice.
 - C. Body dimensions do not include mold flash or protrusion, not to exceed 0,15.

W (R-GDFP-F14)

CERAMIC DUAL FLATPACK



- NOTES:
- A. All linear dimensions are in inches (millimeters).
 - B. This drawing is subject to change without notice.
 - C. This package can be hermetically sealed with a ceramic lid using glass frit.
 - D. Index point is provided on cap for terminal identification only.
 - E. Falls within MIL STD 1835 GDFP1-F14

DB0014A



PACKAGE OUTLINE

SSOP - 2 mm max height

SMALL OUTLINE PACKAGE



NOTES:

1. All linear dimensions are in millimeters. Any dimensions in parenthesis are for reference only. Dimensioning and tolerancing per ASME Y14.5M.
2. This drawing is subject to change without notice.
3. This dimension does not include mold flash, protrusions, or gate burrs. Mold flash, protrusions, or gate burrs shall not exceed 0.15 mm per side.
4. Reference JEDEC registration MO-150.

EXAMPLE BOARD LAYOUT

DB0014A

SSOP - 2 mm max height

SMALL OUTLINE PACKAGE



LAND PATTERN EXAMPLE
EXPOSED METAL SHOWN
SCALE: 10X



4220762/A 05/2024

NOTES: (continued)

- 5. Publication IPC-7351 may have alternate designs.
- 6. Solder mask tolerances between and around signal pads can vary based on board fabrication site.

EXAMPLE STENCIL DESIGN

DB0014A

SSOP - 2 mm max height

SMALL OUTLINE PACKAGE



SOLDER PASTE EXAMPLE
BASED ON 0.125 mm THICK STENCIL
SCALE: 10X

4220762/A 05/2024

NOTES: (continued)

7. Laser cutting apertures with trapezoidal walls and rounded corners may offer better paste release. IPC-7525 may have alternate design recommendations.
8. Board assembly site may have different recommendations for stencil design.

GENERIC PACKAGE VIEW

FK 20

LCCC - 2.03 mm max height

8.89 x 8.89, 1.27 mm pitch

LEADLESS CERAMIC CHIP CARRIER

This image is a representation of the package family, actual package may vary.
Refer to the product data sheet for package details.



4229370VA\

J 14

GENERIC PACKAGE VIEW
CDIP - 5.08 mm max height
CERAMIC DUAL IN LINE PACKAGE



Images above are just a representation of the package family, actual package may vary.
Refer to the product data sheet for package details.

4040083-5/G

J0014A



PACKAGE OUTLINE

CDIP - 5.08 mm max height

CERAMIC DUAL IN LINE PACKAGE



4214771/A 05/2017

NOTES:

1. All controlling linear dimensions are in inches. Dimensions in brackets are in millimeters. Any dimension in brackets or parenthesis are for reference only. Dimensioning and tolerancing per ASME Y14.5M.
2. This drawing is subject to change without notice.
3. This package is hermetically sealed with a ceramic lid using glass frit.
4. Index point is provided on cap for terminal identification only and on press ceramic glass frit seal only.
5. Falls within MIL-STD-1835 and GDIP1-T14.

EXAMPLE BOARD LAYOUT

J0014A

CDIP - 5.08 mm max height

CERAMIC DUAL IN LINE PACKAGE



LAND PATTERN EXAMPLE
NON-SOLDER MASK DEFINED
SCALE: 5X



4214771/A 05/2017

D (R-PDSO-G14)

PLASTIC SMALL OUTLINE



- NOTES:
- A. All linear dimensions are in inches (millimeters).
 - B. This drawing is subject to change without notice.
 -  Body length does not include mold flash, protrusions, or gate burrs. Mold flash, protrusions, or gate burrs shall not exceed 0.006 (0,15) each side.
 -  Body width does not include interlead flash. Interlead flash shall not exceed 0.017 (0,43) each side.
 - E. Reference JEDEC MS-012 variation AB.

D (R-PDSO-G14)

PLASTIC SMALL OUTLINE



4211283-3/E 08/12

- NOTES:
- A. All linear dimensions are in millimeters.
 - B. This drawing is subject to change without notice.
 - C. Publication IPC-7351 is recommended for alternate designs.
 - D. Laser cutting apertures with trapezoidal walls and also rounding corners will offer better paste release. Customers should contact their board assembly site for stencil design recommendations. Refer to IPC-7525 for other stencil recommendations.
 - E. Customers should contact their board fabrication site for solder mask tolerances between and around signal pads.

N (R-PDIP-T**)

PLASTIC DUAL-IN-LINE PACKAGE

16 PINS SHOWN



- NOTES:
- A. All linear dimensions are in inches (millimeters).
 - B. This drawing is subject to change without notice.
 - Falls within JEDEC MS-001, except 18 and 20 pin minimum body length (Dim A).
 - The 20 pin end lead shoulder width is a vendor option, either half or full width.

IMPORTANT NOTICE AND DISCLAIMER

TI PROVIDES TECHNICAL AND RELIABILITY DATA (INCLUDING DATA SHEETS), DESIGN RESOURCES (INCLUDING REFERENCE DESIGNS), APPLICATION OR OTHER DESIGN ADVICE, WEB TOOLS, SAFETY INFORMATION, AND OTHER RESOURCES "AS IS" AND WITH ALL FAULTS, AND DISCLAIMS ALL WARRANTIES, EXPRESS AND IMPLIED, INCLUDING WITHOUT LIMITATION ANY IMPLIED WARRANTIES OF MERCHANTABILITY, FITNESS FOR A PARTICULAR PURPOSE OR NON-INFRINGEMENT OF THIRD PARTY INTELLECTUAL PROPERTY RIGHTS.

These resources are intended for skilled developers designing with TI products. You are solely responsible for (1) selecting the appropriate TI products for your application, (2) designing, validating and testing your application, and (3) ensuring your application meets applicable standards, and any other safety, security, regulatory or other requirements.

These resources are subject to change without notice. TI grants you permission to use these resources only for development of an application that uses the TI products described in the resource. Other reproduction and display of these resources is prohibited. No license is granted to any other TI intellectual property right or to any third party intellectual property right. TI disclaims responsibility for, and you will fully indemnify TI and its representatives against, any claims, damages, costs, losses, and liabilities arising out of your use of these resources.

TI's products are provided subject to [TI's Terms of Sale](#) or other applicable terms available either on [ti.com](https://www.ti.com) or provided in conjunction with such TI products. TI's provision of these resources does not expand or otherwise alter TI's applicable warranties or warranty disclaimers for TI products.

TI objects to and rejects any additional or different terms you may have proposed.

Mailing Address: Texas Instruments, Post Office Box 655303, Dallas, Texas 75265
Copyright © 2024, Texas Instruments Incorporated