

TLV809

3 引脚电源电压监控器

1 特性

- 高精度电源电压监控器：
2.5V、3V、3.3V、5V
- 具有 200ms 固定延时时间的上电复位发生器
- 电源电流：9 μ A (典型值)
- 温度范围：-40°C 至 +85°C
- 3 引脚 SOT-23 封装
- 与 MAX809 引脚对引脚兼容

2 应用

- 工厂自动化
- 便携式和电池供电类设备
- 机顶盒
- 服务器
- 电器
- 电表
- 楼宇自动化

3 说明

TLV809 系列监控电路主要为数字信号处理器 (DSP) 以及基于处理器的系统提供电路初始化和时序监控。较新的 [TLV809E](#) 是引脚对引脚兼容的备选器件。

在启动期间，置位为 $\overline{\text{RESET}}$ ，前提是电源电压 (V_{DD}) 超过 1.1V。之后，监控电路就会监测 V_{DD} ，并使 $\overline{\text{RESET}}$ 保持有效状态，前提是 V_{DD} 保持在阈值电压 V_{IT} 以下。内部计时器将会延迟输出恢复至无效状态 (高电平) 的时间，以确保系统正常复位。延时时间 ($t_{\text{d(typ)}} = 200\text{ms}$) 从 V_{DD} 上升到高于阈值电压 V_{IT} 后开始。当电源电压降至 V_{IT} 阈值电压以下时，输出再次变为有效状态 (低电平)。无需外部组件。该系列中的所有器件均具有一个通过内部分压器设定的固定感应阈值电压 (V_{IT})。

该产品系列专为 2.5V、3V、3.3V 以及 5V 电源电压而设计。电路采用 3 引脚 SOT-23 封装。TLV809 器件的额定工作温度范围为 -40°C 至 +85°C。

器件信息

器件型号	封装 (1)	封装尺寸 (标称值)
TLV809	SOT-23 (3)、DBV	2.90mm × 1.60mm
	SOT-23 (3)、DBZ	2.92mm × 1.30mm

(1) 如需了解所有可用封装，请参阅数据表末尾的可订购产品附录。

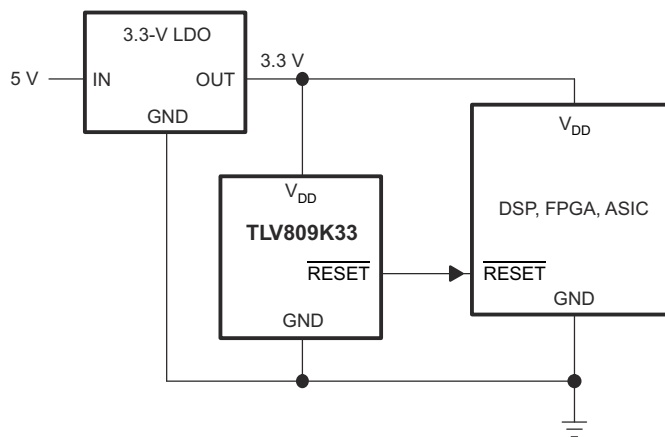

典型应用



Table of Contents

1 特性	1	8.2 Functional Block Diagram.....	9
2 应用	1	8.3 Feature Description.....	9
3 说明	1	8.4 Device Functional Modes.....	9
4 Revision History	2	9 Application and Implementation	10
5 Device Comparison	4	9.1 Application Information.....	10
6 Pin Configuration and Functions	4	9.2 Typical Application.....	11
Pin Functions.....	4	10 Power Supply Recommendations	12
7 Specifications	5	11 Layout	12
7.1 Absolute Maximum Ratings.....	5	11.1 Layout Guidelines.....	12
7.2 ESD Ratings.....	5	11.2 Layout Example.....	12
7.3 Recommended Operating Conditions.....	5	12 Device and Documentation Support	13
7.4 Thermal Information.....	5	12.1 Documentation Support.....	13
7.5 Electrical Characteristics.....	6	12.2 支持资源.....	13
7.6 Timing Requirements.....	6	12.3 Trademarks.....	13
7.7 Switching Characteristics.....	6	12.4 静电放电警告.....	13
7.8 Timing Diagrams.....	7	12.5 术语表.....	13
7.9 Typical Characteristics.....	8	13 Mechanical, Packaging, and Orderable Information	13
8 Detailed Description	9		
8.1 Overview.....	9		

4 Revision History

Changes from Revision E (November 2020) to Revision F (December 2020)	Page
• Corrected missed change of VDD from 7 to 6.5 in <i>Absolute Maximum Ratings</i> for all other pins and in note2.....	5
Changes from Revision D (March 2016) to Revision E (November 2020)	Page
• 更新了整个文档的表、图和交叉参考的编号格式.....	1
• 更新了 <i>描述</i> 部分.....	1
• Updated <i>Device Comparison</i>	4
• Changed VDD from 7 to 6.5 in <i>Absolute Maximum Ratings</i>	5
• Changed V _{OL} @ 500μA from 0.2 to 0.3 in <i>Electrical Characteristics</i>	6
• Changed t _w pulse duration from 3 to 10μs in <i>Timing Requirements</i>	6
• Changed t _{PHL} from 1 to 10μs in <i>Switching Characteristics</i>	6
• Deleted figure for Minimum Pulse Duration At V _{DD} in Typical Characteristics.....	8
• Changed figure from Pulse Duration to V _{OL} , I _{OL} in the Typical Application Section.....	11
Changes from Revision C (February 2012) to Revision D (March 2016)	Page
• 添加了 <i>器件信息表</i> 、 <i>引脚配置和功能</i> 部分、 <i>ESD 等级表</i> 、 <i>概述</i> 部分、 <i>特性描述</i> 部分、 <i>器件功能模式</i> 部分、 <i>应用和实施</i> 部分、 <i>电源相关建议</i> 部分、 <i>布局</i> 部分、 <i>器件和文档支持</i> 部分以及 <i>机械、封装和可订购信息</i> 部分.....	1
• 删除了第 1 页中的引脚排列图.....	1
• 更改了 <i>描述</i> 部分：添加了第三段，更改了这部分的措辞，使之更加清晰.....	1
• Deleted soldering temperature parameter from <i>Absolute Maximum Ratings</i> table.....	5
• Changed I _{DD} parameter test conditions in <i>Electrical Characteristics</i> table.....	6
Changes from Revision B (September 2010) to Revision C (February 2012)	Page
• Updated ordering information.....	4
Changes from Revision A (July 2010) to Revision B (September 2010)	Page
• 已按照最新标准更新了文档格式.....	1
• 在引脚排列图上增加了 DBZ 封装.....	1
• Added <i>Thermal Information</i> table.....	5

• Changed  7-3	8
---	---

5 Device Comparison

表 5-1. Device Threshold Options

PRODUCT	THRESHOLD VOLTAGE
TLV809J25	2.25 V
TLV809L30	2.64 V
TLV809K33	2.93 V
TLV809I50	4.55 V

表 5-2. Device Family Comparison

DEVICE	FUNCTION
TLV803	Open-Drain, $\overline{\text{RESET}}$ Output
TLV809	Push-Pull, $\overline{\text{RESET}}$ Output
TLV810	Push-Pull, RESET Output

6 Pin Configuration and Functions

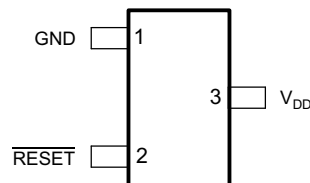

**图 6-1. DBV, DBZ Packages
3-Pin SOT-23
Top View**

Pin Functions

PIN		I/O	DESCRIPTION
NO.	NAME		
1	GND	—	Ground pin. This pin must be connected to ground with a low-impedance connection.
2	RESET	O	$\overline{\text{RESET}}$ pin. $\overline{\text{RESET}}$ is an active low signal, asserting when V_{DD} is below the threshold voltage. When V_{DD} rises above V_{IT} , there is a delay time (t_d) until $\overline{\text{RESET}}$ deasserts. $\overline{\text{RESET}}$ is a push-pull output stage.
3	V_{DD}	I	Supply voltage pin. A 0.1- μF ceramic capacitor from this pin to ground is recommended to improve stability of the threshold voltage.

7 Specifications

7.1 Absolute Maximum Ratings

over operating free-air temperature range (unless otherwise noted)⁽¹⁾

		MIN	MAX	UNIT
V _{DD}	Supply voltage ⁽²⁾		6.5	V
	All other pins ⁽²⁾	-0.3	6.5	
I _{OL}	Maximum low output current		5	mA
I _{OH}	Maximum high output current		-5	mA
I _{IK}	Input clamp current (V _I < 0 or V _I > V _{DD})		±20	mA
I _{OK}	Output clamp current (V _O < 0 or V _O > V _{DD})		±20	mA
T _A	Operating free-air temperature	-40	85	°C
T _{stg}	Storage temperature	-65	150	°C

- (1) Stresses beyond those listed under *Absolute Maximum Ratings* may cause permanent damage to the device. These are stress ratings only, which do not imply functional operation of the device at these or any other conditions beyond those indicated under *Recommended Operating Conditions*. Exposure to absolute-maximum-rated conditions for extended periods may affect device reliability.
- (2) All voltage values are with respect to GND. For reliable operation, do not operate the device at 6.5 V for more than t = 1000h continuously.

7.2 ESD Ratings

			VALUE	UNIT
V _(ESD)	Electrostatic discharge	Human-body model (HBM), per ANSI/ESDA/JEDEC JS-001 ⁽¹⁾	±2000	V
		Charged-device model (CDM), per JEDEC specification JESD22-C101 ⁽²⁾	±500	

- (1) JEDEC document JEP155 states that 500-V HBM allows safe manufacturing with a standard ESD control process.
- (2) JEDEC document JEP157 states that 250-V CDM allows safe manufacturing with a standard ESD control process.

7.3 Recommended Operating Conditions

at specified temperature range (unless otherwise noted)

		MIN	NOM	MAX	UNIT
V _{DD}	Supply voltage	2		6	V
C _{IN}	V _{DD} bypass capacitor		0.1		µF
T _A	Operating free-air temperature range	-40		85	°C

7.4 Thermal Information

THERMAL METRIC ⁽¹⁾		TLV809		UNIT
		DBV (SOT-23)	DBZ (SOT-23)	
		3 PINS	3 PINS	
R _{θJA}	Junction-to-ambient thermal resistance	242.1	286.9	°C/W
R _{θJC(top)}	Junction-to-case (top) thermal resistance	213.0	105.6	°C/W
R _{θJB}	Junction-to-board thermal resistance	123.4	124.4	°C/W
ψ _{JT}	Junction-to-top characterization parameter	45.7	25.8	°C/W
ψ _{JB}	Junction-to-board characterization parameter	130.9	107.9	°C/W
R _{θJC(bot)}	Junction-to-case (bottom) thermal resistance	—	—	°C/W

- (1) For more information about traditional and new thermal metrics, see the *Semiconductor and IC Package Thermal Metrics* application report, [SPRA953](#).

7.5 Electrical Characteristics

at $T_A = -40^\circ\text{C}$ to $+85^\circ\text{C}$ (unless otherwise noted); typical values are at $T_A = 25^\circ\text{C}$

PARAMETER		TEST CONDITIONS	MIN	TYP	MAX	UNIT	
V_{OH}	High-level output voltage	$V_{DD} = 2.5\text{ V to }6\text{ V}, I_{OH} = -500\ \mu\text{A}$	$V_{DD} - 0.2$			V	
		$V_{DD} = 3.3\text{ V}, I_{OH} = -2\text{ mA}$	$V_{DD} - 0.4$				
		$V_{DD} = 6\text{ V}, I_{OH} = -4\text{ mA}$	$V_{DD} - 0.4$				
V_{OL}	Low-level output voltage	$V_{DD} = 2\text{ V to }6\text{ V}, I_{OH} = 500\ \mu\text{A}$	0.3			V	
		$V_{DD} = 3.3\text{ V}, I_{OH} = 2\text{ mA}$	0.4				
		$V_{DD} = 6\text{ V}, I_{OH} = 4\text{ mA}$	0.4				
Power-up reset voltage ⁽¹⁾		$V_{DD} \geq 1.1\text{ V}, I_{OL} = 50\ \mu\text{A}$	0.2			V	
V_{IT-}	Negative-going input threshold voltage ⁽²⁾	$T_A = -40^\circ\text{C to }+85^\circ\text{C}$	TLV809J25	2.20	2.25	2.30	V
			TLV809L30	2.58	2.64	2.70	
			TLV809K33	2.87	2.93	2.99	
			TLV809I50	4.45	4.55	4.65	
V_{hys}	Hysteresis		TLV809J25	30		mV	
			TLV809L30	35			
			TLV809K33	40			
			TLV809I50	60			
I_{DD}	Supply current	$V_{DD} = 2\text{ V}, \overline{\text{RESET}}$ is unconnected	9		12	μA	
		$V_{DD} = 6\text{ V}, \overline{\text{RESET}}$ is unconnected	20		25		
C_I	Input capacitance	$V_I = 0\text{ V to }V_{DD}$	5			pF	

(1) The lowest supply voltage at which $\overline{\text{RESET}}$ becomes active. $t_r, V_{DD} \geq 15\text{ ms/V}$.

(2) To ensure best stability of the threshold voltage, place a bypass capacitor (0.1- μF ceramic) near the supply pins.

7.6 Timing Requirements

at $T_A = 25^\circ\text{C}$, $R_L = 1\text{ M}\Omega$, and $C_L = 50\text{ pF}$

		MIN	NOM	MAX	UNIT
t_w	Pulse duration at V_{DD}	$V_{DD} = V_{IT-} + 0.2\text{ V}, V_{DD} = V_{IT-} - 0.2\text{ V}$		10	μs

7.7 Switching Characteristics

at $T_A = 25^\circ\text{C}$, $R_L = 1\text{ M}\Omega$, and $C_L = 50\text{ pF}$

PARAMETER		TEST CONDITIONS	MIN	TYP	MAX	UNIT
t_d	Delay time	$V_{DD} \geq V_{IT-} + 0.2\text{ V}$; see Figure 7-1	120	200	280	ms
t_{PHL}	Propagation (delay) time, high-to-low-level output	V_{DD} to $\overline{\text{RESET}}$ delay $V_{IL} = V_{IT-} - 0.2\text{ V}, V_{IH} = V_{IT-} + 0.2\text{ V}$	10			μs

7.8 Timing Diagrams



图 7-1. Timing Diagram

7.9 Typical Characteristics



图 7-2. Low-Level Output Voltage vs Low-Level Output Current

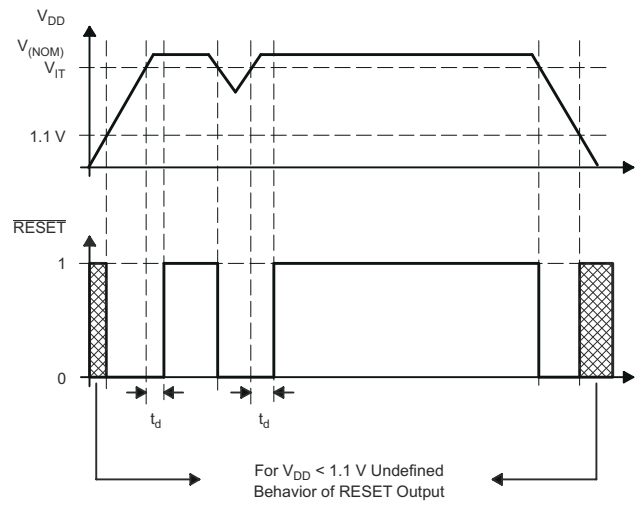

图 7-3. Supply Current vs Supply Voltage

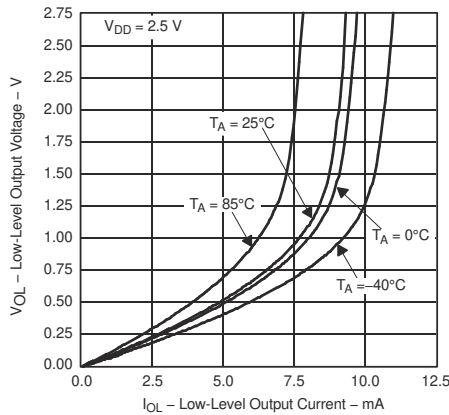

图 7-4. High-Level Output Voltage vs High-Level Output Current

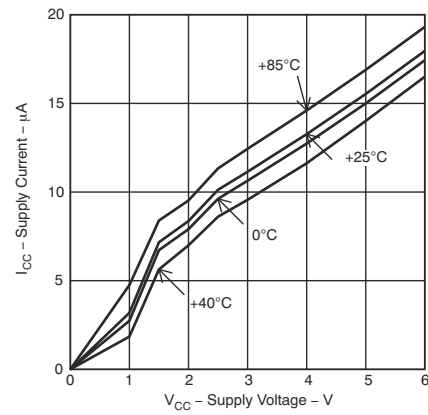

图 7-5. High-Level Output Voltage vs High-Level Output Current

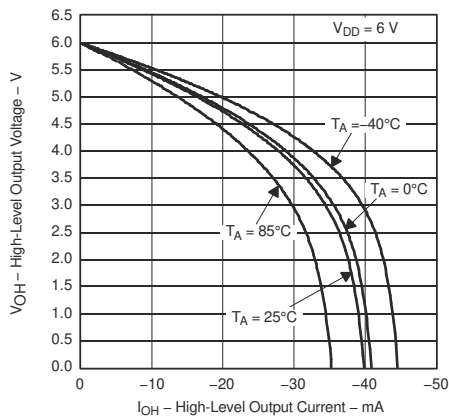

图 7-6. Normalized Input Threshold Voltage vs Free-Air Temperature at V_{DD}

8 Detailed Description

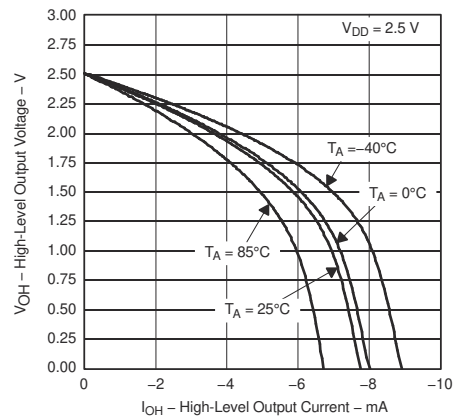
8.1 Overview

The TLV809 is a 3-pin voltage detector with fixed detection thresholds, an active-low push-pull $\overline{\text{RESET}}$ output, and an internal timer to delay the $\overline{\text{RESET}}$ signal when V_{DD} rises above the threshold voltage.

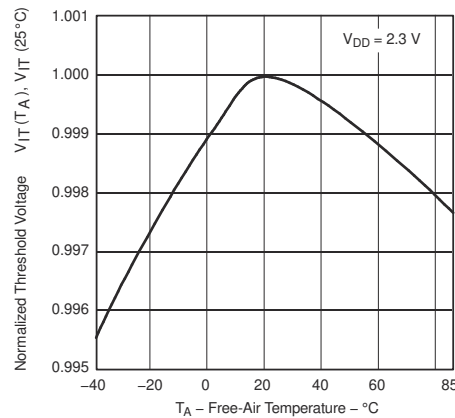
8.2 Functional Block Diagram

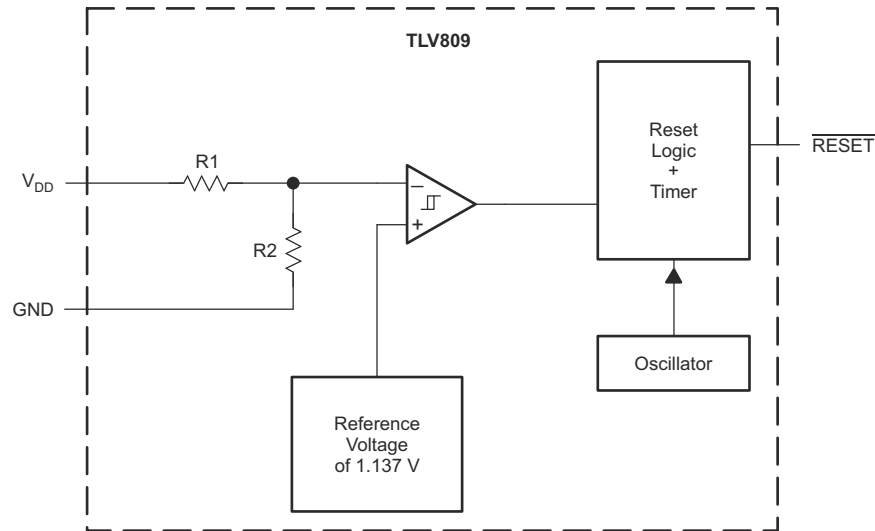

8.3 Feature Description

8.3.1 Supply Voltage Monitoring

The device actively monitors its supply voltage to ensure that the power supply is above a certain voltage threshold.

The device offers various fixed threshold options that are approximately 10% below several standard supply voltages (2.5 V, 3.0 V, 3.3 V, 5.0 V).

8.3.2 $\overline{\text{RESET}}$ Output

The device has a $\overline{\text{RESET}}$ output to indicate the status of the input power supply.

$\overline{\text{RESET}}$ is an active low signal, asserting when V_{DD} is below the threshold voltage. When V_{DD} rises above V_{IT} , there is a delay time (t_d) until $\overline{\text{RESET}}$ deasserts.

$\overline{\text{RESET}}$ is a push-pull output stage.

8.4 Device Functional Modes

When the input supply voltage is in its recommended operating range (2 V to 6 V), the device is in a normal operational mode. In normal operational mode the device monitors V_{DD} for undervoltage detection.

When the input supply is below its recommended operating range, the device is in shutdown mode and therefore tries to assert $\overline{\text{RESET}}$.

9 Application and Implementation

备注

以下应用部分中的信息不属于 TI 器件规格的范围，TI 不担保其准确性和完整性。TI 的客户应负责确定器件是否适用于其应用。客户应验证并测试其设计，以确保系统功能。

9.1 Application Information

9.1.1 V_{DD} Transient Rejection

The device has built-in rejection of fast transients on the V_{DD} pin. The rejection of transients depends on both the duration and the amplitude of the transient. The amplitude of the transient is measured from the bottom of the transient to the negative threshold voltage of the device, as shown in 图 9-1.



图 9-1. Voltage Transient Measurement

The device does not respond to transients that are fast duration and low amplitude or long duration and small amplitude. Transients meeting or longer than the t_w specified in the 节 7.6 section triggers a reset.

9.1.2 Reset During Power-Up and Power-Down

The device output is valid when V_{DD} is greater than 1.1 V. When V_{DD} is less than 1.1 V, the output transistor turns off and becomes high impedance. The voltage on the $\overline{\text{RESET}}$ pin rises to the voltage level connected to the pullup resistor. 图 9-2 shows a typical waveform for power-up.

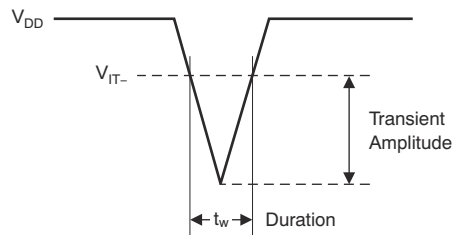

图 9-2. Power-Up Response

9.2 Typical Application

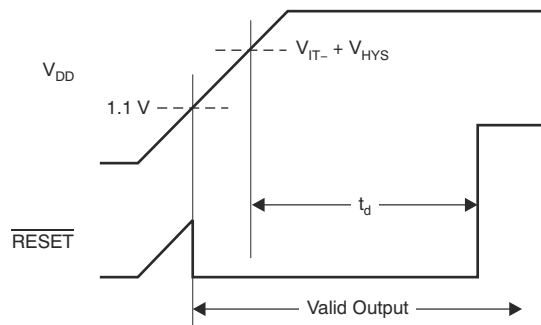

图 9-3. Monitoring a 3.3-V Supply

9.2.1 Design Requirements

The device must ensure that the supply voltage does not drop more than 15% below 3.3 V. If the supply voltage falls below 3.3 V – 15%, then the load must be disabled.

9.2.2 Detailed Design Procedure

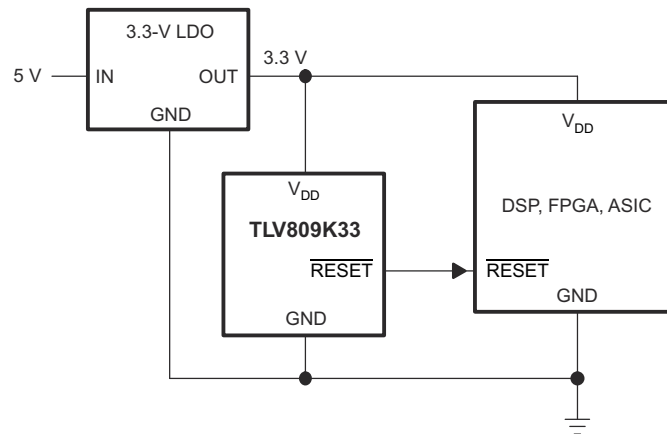
The TLV809K33 is selected to ensure that V_{DD} is greater than 2.87 V when the load is enabled.

9.2.3 Application Curve



图 9-4. Low-Level Output Voltage vs Low-Level Output Current

10 Power Supply Recommendations

Power the device with a low-impedance supply. A 0.1- μF bypass capacitor from V_{DD} to ground is recommended.

11 Layout

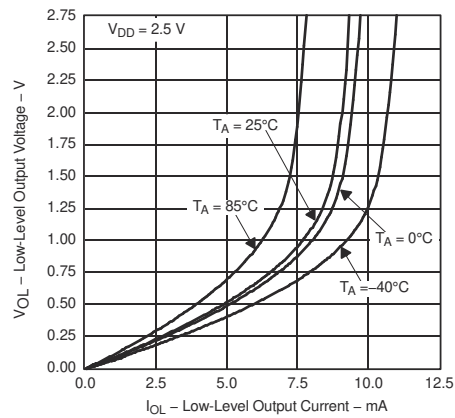
11.1 Layout Guidelines

Place the device near the load for the input power supply, with a low-impedance connection to the power supply pins of the load to sense the supply voltage.

11.2 Layout Example



图 11-1. Example Layout

12 Device and Documentation Support

12.1 Documentation Support

12.1.1 Related Documentation

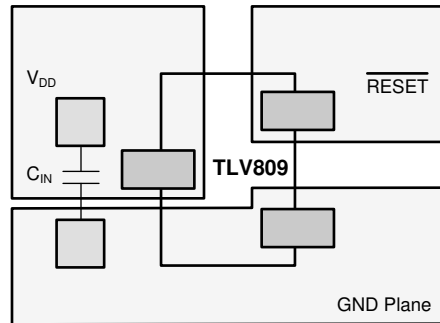
TLV803 Data Sheet, [SBVS157](#)

TLV810 Data Sheet, [SBVS158](#)

12.2 支持资源

TI E2E™ 支持论坛是工程师的重要参考资料，可直接从专家获得快速、经过验证的解答和设计帮助。搜索现有解答或提出自己的问题可获得所需的快速设计帮助。

链接的内容由各个贡献者“按原样”提供。这些内容并不构成 TI 技术规范，并且不一定反映 TI 的观点；请参阅 TI 的《[使用条款](#)》。

12.3 Trademarks

TI E2E™ is a trademark of Texas Instruments.
所有商标均为其各自所有者的财产。

12.4 静电放电警告



静电放电 (ESD) 会损坏这个集成电路。德州仪器 (TI) 建议通过适当的预防措施处理所有集成电路。如果不遵守正确的处理和安装程序，可能会损坏集成电路。

ESD 的损坏小至导致微小的性能降级，大至整个器件故障。精密的集成电路可能更容易受到损坏，这是因为非常细微的参数更改都可能会导致器件与其发布的规格不相符。

12.5 术语表

[TI 术语表](#) 本术语表列出并解释了术语、首字母缩略词和定义。

13 Mechanical, Packaging, and Orderable Information

The following pages include mechanical, packaging, and orderable information. This information is the most current data available for the designated devices. This data is subject to change without notice and revision of this document. For browser-based versions of this data sheet, refer to the left-hand navigation.

PACKAGING INFORMATION

Orderable part number	Status (1)	Material type (2)	Package Pins	Package qty Carrier	RoHS (3)	Lead finish/ Ball material (4)	MSL rating/ Peak reflow (5)	Op temp (°C)	Part marking (6)
TLV809I50DBVR	Active	Production	SOT-23 (DBV) 3	3000 LARGE T&R	Yes	NIPDAU	Level-1-260C-UNLIM	-40 to 85	VTBI
TLV809I50DBVR.A	Active	Production	SOT-23 (DBV) 3	3000 LARGE T&R	Yes	NIPDAU	Level-1-260C-UNLIM	-40 to 85	VTBI
TLV809I50DBVT	Active	Production	SOT-23 (DBV) 3	250 SMALL T&R	Yes	NIPDAU	Level-1-260C-UNLIM	-40 to 85	VTBI
TLV809I50DBVT.A	Active	Production	SOT-23 (DBV) 3	250 SMALL T&R	Yes	NIPDAU	Level-1-260C-UNLIM	-40 to 85	VTBI
TLV809I50DBZR	Active	Production	SOT-23 (DBZ) 3	3000 LARGE T&R	Yes	NIPDAU SN	Level-1-260C-UNLIM	-40 to 85	BCMV
TLV809I50DBZR.A	Active	Production	SOT-23 (DBZ) 3	3000 LARGE T&R	Yes	NIPDAU	Level-1-260C-UNLIM	-40 to 85	BCMV
TLV809I50DBZT	Active	Production	SOT-23 (DBZ) 3	250 SMALL T&R	Yes	NIPDAU SN	Level-1-260C-UNLIM	-40 to 85	BCMV
TLV809I50DBZT.A	Active	Production	SOT-23 (DBZ) 3	250 SMALL T&R	Yes	NIPDAU	Level-1-260C-UNLIM	-40 to 85	BCMV
TLV809J25DBVR	Active	Production	SOT-23 (DBV) 3	3000 LARGE T&R	Yes	NIPDAU	Level-1-260C-UNLIM	-40 to 85	VTCI
TLV809J25DBVR.A	Active	Production	SOT-23 (DBV) 3	3000 LARGE T&R	Yes	NIPDAU	Level-1-260C-UNLIM	-40 to 85	VTCI
TLV809J25DBVT	Active	Production	SOT-23 (DBV) 3	250 SMALL T&R	Yes	NIPDAU	Level-1-260C-UNLIM	-40 to 85	VTCI
TLV809J25DBVT.A	Active	Production	SOT-23 (DBV) 3	250 SMALL T&R	Yes	NIPDAU	Level-1-260C-UNLIM	-40 to 85	VTCI
TLV809J25DBZR	Active	Production	SOT-23 (DBZ) 3	3000 LARGE T&R	Yes	NIPDAU SN	Level-1-260C-UNLIM	-40 to 85	BCMT
TLV809J25DBZR.A	Active	Production	SOT-23 (DBZ) 3	3000 LARGE T&R	Yes	NIPDAU	Level-1-260C-UNLIM	-40 to 85	BCMT
TLV809J25DBZT	Active	Production	SOT-23 (DBZ) 3	250 SMALL T&R	Yes	NIPDAU SN NIPDAUAG	Level-1-260C-UNLIM	-40 to 85	BCMT
TLV809J25DBZT.A	Active	Production	SOT-23 (DBZ) 3	250 SMALL T&R	Yes	NIPDAU	Level-1-260C-UNLIM	-40 to 85	BCMT
TLV809K33DBVR	Active	Production	SOT-23 (DBV) 3	3000 LARGE T&R	Yes	NIPDAU	Level-1-260C-UNLIM	-40 to 85	VTRI
TLV809K33DBVR.A	Active	Production	SOT-23 (DBV) 3	3000 LARGE T&R	Yes	NIPDAU	Level-1-260C-UNLIM	-40 to 85	VTRI
TLV809K33DBVT	Active	Production	SOT-23 (DBV) 3	250 SMALL T&R	Yes	NIPDAU	Level-1-260C-UNLIM	-40 to 85	VTRI
TLV809K33DBVT.A	Active	Production	SOT-23 (DBV) 3	250 SMALL T&R	Yes	NIPDAU	Level-1-260C-UNLIM	-40 to 85	VTRI
TLV809K33DBZR	Active	Production	SOT-23 (DBZ) 3	3000 LARGE T&R	Yes	NIPDAU SN	Level-1-260C-UNLIM	-40 to 85	BCMX
TLV809K33DBZR.A	Active	Production	SOT-23 (DBZ) 3	3000 LARGE T&R	Yes	NIPDAU	Level-1-260C-UNLIM	-40 to 85	BCMX
TLV809K33DBZT	Active	Production	SOT-23 (DBZ) 3	250 SMALL T&R	Yes	NIPDAU SN	Level-1-260C-UNLIM	-40 to 85	BCMX
TLV809K33DBZT.A	Active	Production	SOT-23 (DBZ) 3	250 SMALL T&R	Yes	NIPDAU	Level-1-260C-UNLIM	-40 to 85	BCMX
TLV809L30DBVR	Active	Production	SOT-23 (DBV) 3	3000 LARGE T&R	Yes	NIPDAU	Level-1-260C-UNLIM	-40 to 85	VTXI
TLV809L30DBVR.A	Active	Production	SOT-23 (DBV) 3	3000 LARGE T&R	Yes	NIPDAU	Level-1-260C-UNLIM	-40 to 85	VTXI
TLV809L30DBVT	Active	Production	SOT-23 (DBV) 3	250 SMALL T&R	Yes	NIPDAU	Level-1-260C-UNLIM	-40 to 85	VTXI
TLV809L30DBVT.A	Active	Production	SOT-23 (DBV) 3	250 SMALL T&R	Yes	NIPDAU	Level-1-260C-UNLIM	-40 to 85	VTXI

Orderable part number	Status (1)	Material type (2)	Package Pins	Package qty Carrier	RoHS (3)	Lead finish/ Ball material (4)	MSL rating/ Peak reflow (5)	Op temp (°C)	Part marking (6)
TLV809L30DBZR	Active	Production	SOT-23 (DBZ) 3	3000 LARGE T&R	Yes	NIPDAU SN	Level-1-260C-UNLIM	-40 to 85	BCMZ
TLV809L30DBZR.A	Active	Production	SOT-23 (DBZ) 3	3000 LARGE T&R	Yes	NIPDAU	Level-1-260C-UNLIM	-40 to 85	BCMZ
TLV809L30DBZT	Active	Production	SOT-23 (DBZ) 3	250 SMALL T&R	Yes	NIPDAU SN	Level-1-260C-UNLIM	-40 to 85	BCMZ
TLV809L30DBZT.A	Active	Production	SOT-23 (DBZ) 3	250 SMALL T&R	Yes	NIPDAU	Level-1-260C-UNLIM	-40 to 85	BCMZ

(1) **Status:** For more details on status, see our [product life cycle](#).

(2) **Material type:** When designated, preproduction parts are prototypes/experimental devices, and are not yet approved or released for full production. Testing and final process, including without limitation quality assurance, reliability performance testing, and/or process qualification, may not yet be complete, and this item is subject to further changes or possible discontinuation. If available for ordering, purchases will be subject to an additional waiver at checkout, and are intended for early internal evaluation purposes only. These items are sold without warranties of any kind.

(3) **RoHS values:** Yes, No, RoHS Exempt. See the [TI RoHS Statement](#) for additional information and value definition.

(4) **Lead finish/Ball material:** Parts may have multiple material finish options. Finish options are separated by a vertical ruled line. Lead finish/Ball material values may wrap to two lines if the finish value exceeds the maximum column width.

(5) **MSL rating/Peak reflow:** The moisture sensitivity level ratings and peak solder (reflow) temperatures. In the event that a part has multiple moisture sensitivity ratings, only the lowest level per JEDEC standards is shown. Refer to the shipping label for the actual reflow temperature that will be used to mount the part to the printed circuit board.

(6) **Part marking:** There may be an additional marking, which relates to the logo, the lot trace code information, or the environmental category of the part.

Multiple part markings will be inside parentheses. Only one part marking contained in parentheses and separated by a "-" will appear on a part. If a line is indented then it is a continuation of the previous line and the two combined represent the entire part marking for that device.

Important Information and Disclaimer:The information provided on this page represents TI's knowledge and belief as of the date that it is provided. TI bases its knowledge and belief on information provided by third parties, and makes no representation or warranty as to the accuracy of such information. Efforts are underway to better integrate information from third parties. TI has taken and continues to take reasonable steps to provide representative and accurate information but may not have conducted destructive testing or chemical analysis on incoming materials and chemicals. TI and TI suppliers consider certain information to be proprietary, and thus CAS numbers and other limited information may not be available for release.

In no event shall TI's liability arising out of such information exceed the total purchase price of the TI part(s) at issue in this document sold by TI to Customer on an annual basis.

TAPE AND REEL INFORMATION

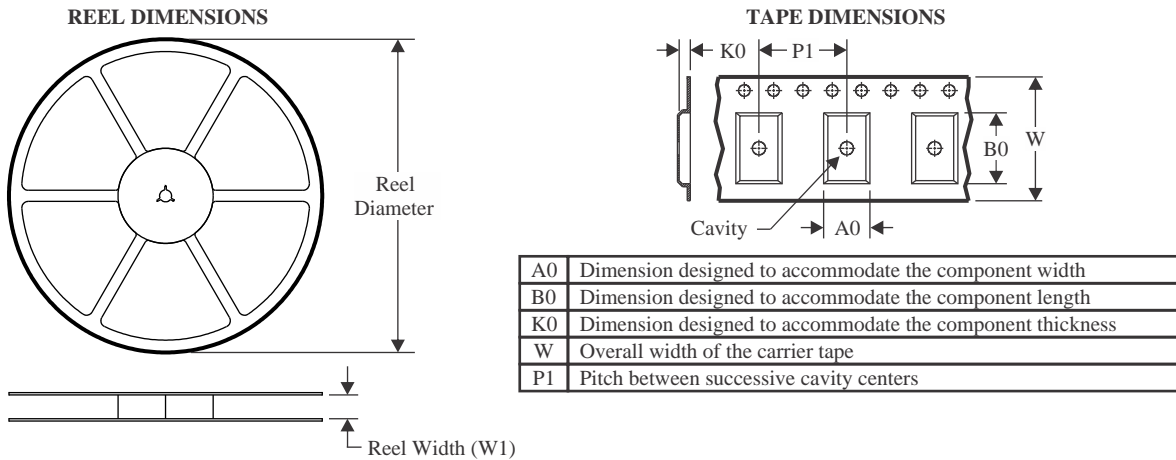

QUADRANT ASSIGNMENTS FOR PIN 1 ORIENTATION IN TAPE

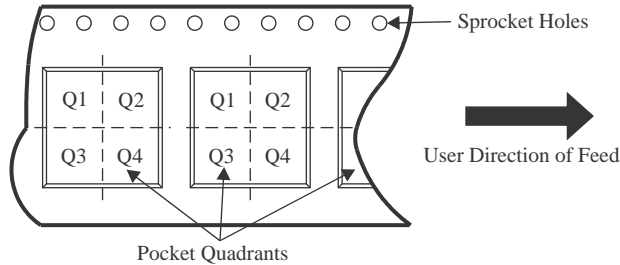

*All dimensions are nominal

Device	Package Type	Package Drawing	Pins	SPQ	Reel Diameter (mm)	Reel Width W1 (mm)	A0 (mm)	B0 (mm)	K0 (mm)	P1 (mm)	W (mm)	Pin1 Quadrant
TLV809I50DBVR	SOT-23	DBV	3	3000	178.0	9.0	3.3	3.2	1.4	4.0	8.0	Q3
TLV809I50DBVT	SOT-23	DBV	3	250	178.0	9.0	3.3	3.2	1.4	4.0	8.0	Q3
TLV809I50DBZR	SOT-23	DBZ	3	3000	178.0	9.0	3.15	2.77	1.22	4.0	8.0	Q3
TLV809I50DBZR	SOT-23	DBZ	3	3000	180.0	8.4	2.9	3.35	1.35	4.0	8.0	Q3
TLV809I50DBZT	SOT-23	DBZ	3	250	180.0	8.4	2.9	3.35	1.35	4.0	8.0	Q3
TLV809I50DBZT	SOT-23	DBZ	3	250	178.0	9.0	3.15	2.77	1.22	4.0	8.0	Q3
TLV809J25DBVR	SOT-23	DBV	3	3000	178.0	9.0	3.3	3.2	1.4	4.0	8.0	Q3
TLV809J25DBVT	SOT-23	DBV	3	250	178.0	9.0	3.3	3.2	1.4	4.0	8.0	Q3
TLV809J25DBZR	SOT-23	DBZ	3	3000	180.0	8.4	2.9	3.35	1.35	4.0	8.0	Q3
TLV809J25DBZT	SOT-23	DBZ	3	250	180.0	8.4	2.9	3.35	1.35	4.0	8.0	Q3
TLV809J25DBZT	SOT-23	DBZ	3	250	178.0	9.0	3.15	2.77	1.22	4.0	8.0	Q3
TLV809K33DBVR	SOT-23	DBV	3	3000	178.0	9.0	3.3	3.2	1.4	4.0	8.0	Q3
TLV809K33DBVT	SOT-23	DBV	3	250	178.0	9.0	3.3	3.2	1.4	4.0	8.0	Q3
TLV809K33DBZR	SOT-23	DBZ	3	3000	180.0	8.4	2.9	3.35	1.35	4.0	8.0	Q3
TLV809K33DBZT	SOT-23	DBZ	3	250	178.0	9.0	3.15	2.77	1.22	4.0	8.0	Q3
TLV809K33DBZT	SOT-23	DBZ	3	250	180.0	8.4	2.9	3.35	1.35	4.0	8.0	Q3

Device	Package Type	Package Drawing	Pins	SPQ	Reel Diameter (mm)	Reel Width W1 (mm)	A0 (mm)	B0 (mm)	K0 (mm)	P1 (mm)	W (mm)	Pin1 Quadrant
TLV809L30DBVR	SOT-23	DBV	3	3000	178.0	9.0	3.3	3.2	1.4	4.0	8.0	Q3
TLV809L30DBVT	SOT-23	DBV	3	250	178.0	9.0	3.3	3.2	1.4	4.0	8.0	Q3
TLV809L30DBZR	SOT-23	DBZ	3	3000	178.0	9.0	3.15	2.77	1.22	4.0	8.0	Q3
TLV809L30DBZR	SOT-23	DBZ	3	3000	180.0	8.4	2.9	3.35	1.35	4.0	8.0	Q3
TLV809L30DBZT	SOT-23	DBZ	3	250	178.0	9.0	3.15	2.77	1.22	4.0	8.0	Q3
TLV809L30DBZT	SOT-23	DBZ	3	250	180.0	8.4	2.9	3.35	1.35	4.0	8.0	Q3

TAPE AND REEL BOX DIMENSIONS

*All dimensions are nominal

Device	Package Type	Package Drawing	Pins	SPQ	Length (mm)	Width (mm)	Height (mm)
TLV809I50DBVR	SOT-23	DBV	3	3000	180.0	180.0	18.0
TLV809I50DBVT	SOT-23	DBV	3	250	180.0	180.0	18.0
TLV809I50DBZR	SOT-23	DBZ	3	3000	180.0	180.0	18.0
TLV809I50DBZR	SOT-23	DBZ	3	3000	210.0	185.0	35.0
TLV809I50DBZT	SOT-23	DBZ	3	250	210.0	185.0	35.0
TLV809I50DBZT	SOT-23	DBZ	3	250	180.0	180.0	18.0
TLV809J25DBVR	SOT-23	DBV	3	3000	180.0	180.0	18.0
TLV809J25DBVT	SOT-23	DBV	3	250	180.0	180.0	18.0
TLV809J25DBZR	SOT-23	DBZ	3	3000	210.0	185.0	35.0
TLV809J25DBZT	SOT-23	DBZ	3	250	210.0	185.0	35.0
TLV809J25DBZT	SOT-23	DBZ	3	250	180.0	180.0	18.0
TLV809K33DBVR	SOT-23	DBV	3	3000	180.0	180.0	18.0
TLV809K33DBVT	SOT-23	DBV	3	250	180.0	180.0	18.0
TLV809K33DBZR	SOT-23	DBZ	3	3000	210.0	185.0	35.0
TLV809K33DBZT	SOT-23	DBZ	3	250	180.0	180.0	18.0
TLV809K33DBZT	SOT-23	DBZ	3	250	210.0	185.0	35.0
TLV809L30DBVR	SOT-23	DBV	3	3000	180.0	180.0	18.0
TLV809L30DBVT	SOT-23	DBV	3	250	180.0	180.0	18.0

Device	Package Type	Package Drawing	Pins	SPQ	Length (mm)	Width (mm)	Height (mm)
TLV809L30DBZR	SOT-23	DBZ	3	3000	180.0	180.0	18.0
TLV809L30DBZR	SOT-23	DBZ	3	3000	210.0	185.0	35.0
TLV809L30DBZT	SOT-23	DBZ	3	250	180.0	180.0	18.0
TLV809L30DBZT	SOT-23	DBZ	3	250	210.0	185.0	35.0

DBZ0003A

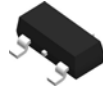

PACKAGE OUTLINE

SOT-23 - 1.12 mm max height

SMALL OUTLINE TRANSISTOR

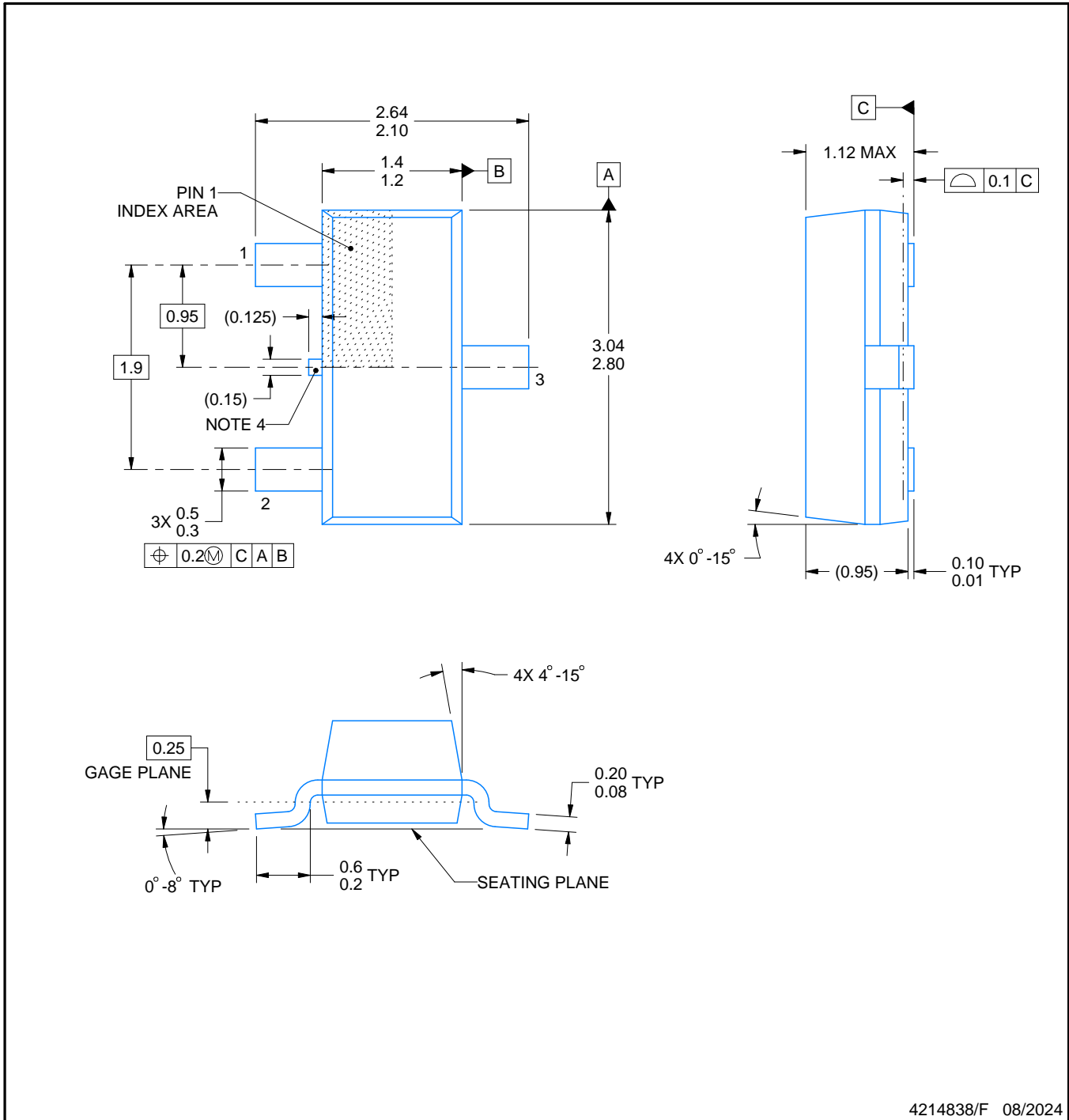

4214838/F 08/2024

NOTES:

- All linear dimensions are in millimeters. Any dimensions in parenthesis are for reference only. Dimensioning and tolerancing per ASME Y14.5M.
- This drawing is subject to change without notice.
- Reference JEDEC registration TO-236, except minimum foot length.
- Support pin may differ or may not be present.
- Body dimensions do not include mold flash, protrusions, or gate burrs. Mold flash, protrusions, or gate burrs shall not exceed 0.25mm per side

EXAMPLE BOARD LAYOUT

DBZ0003A

SOT-23 - 1.12 mm max height

SMALL OUTLINE TRANSISTOR

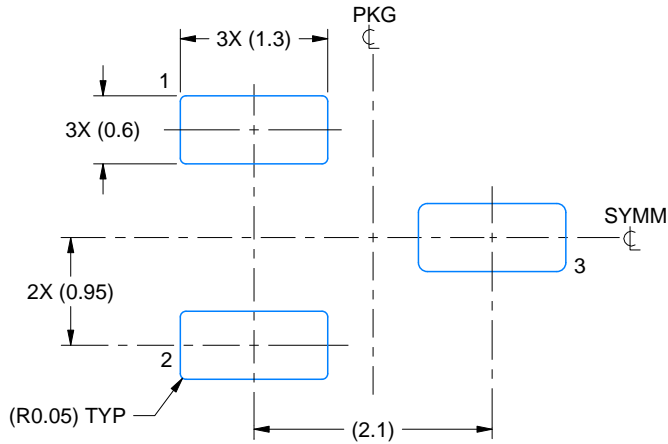

LAND PATTERN EXAMPLE
SCALE:15X



SOLDER MASK DETAILS

4214838/F 08/2024

NOTES: (continued)

5. Publication IPC-7351 may have alternate designs.
6. Solder mask tolerances between and around signal pads can vary based on board fabrication site.

EXAMPLE STENCIL DESIGN

DBZ0003A

SOT-23 - 1.12 mm max height

SMALL OUTLINE TRANSISTOR

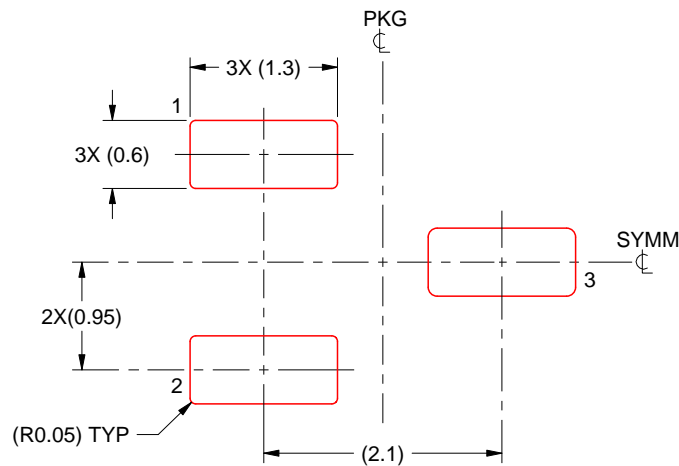

SOLDER PASTE EXAMPLE
BASED ON 0.125 THICK STENCIL
SCALE:15X

4214838/F 08/2024

NOTES: (continued)

7. Laser cutting apertures with trapezoidal walls and rounded corners may offer better paste release. IPC-7525 may have alternate design recommendations.
8. Board assembly site may have different recommendations for stencil design.



DBV0003A

PACKAGE OUTLINE

SOT-23 - 1.45 mm max height

SMALL OUTLINE TRANSISTOR

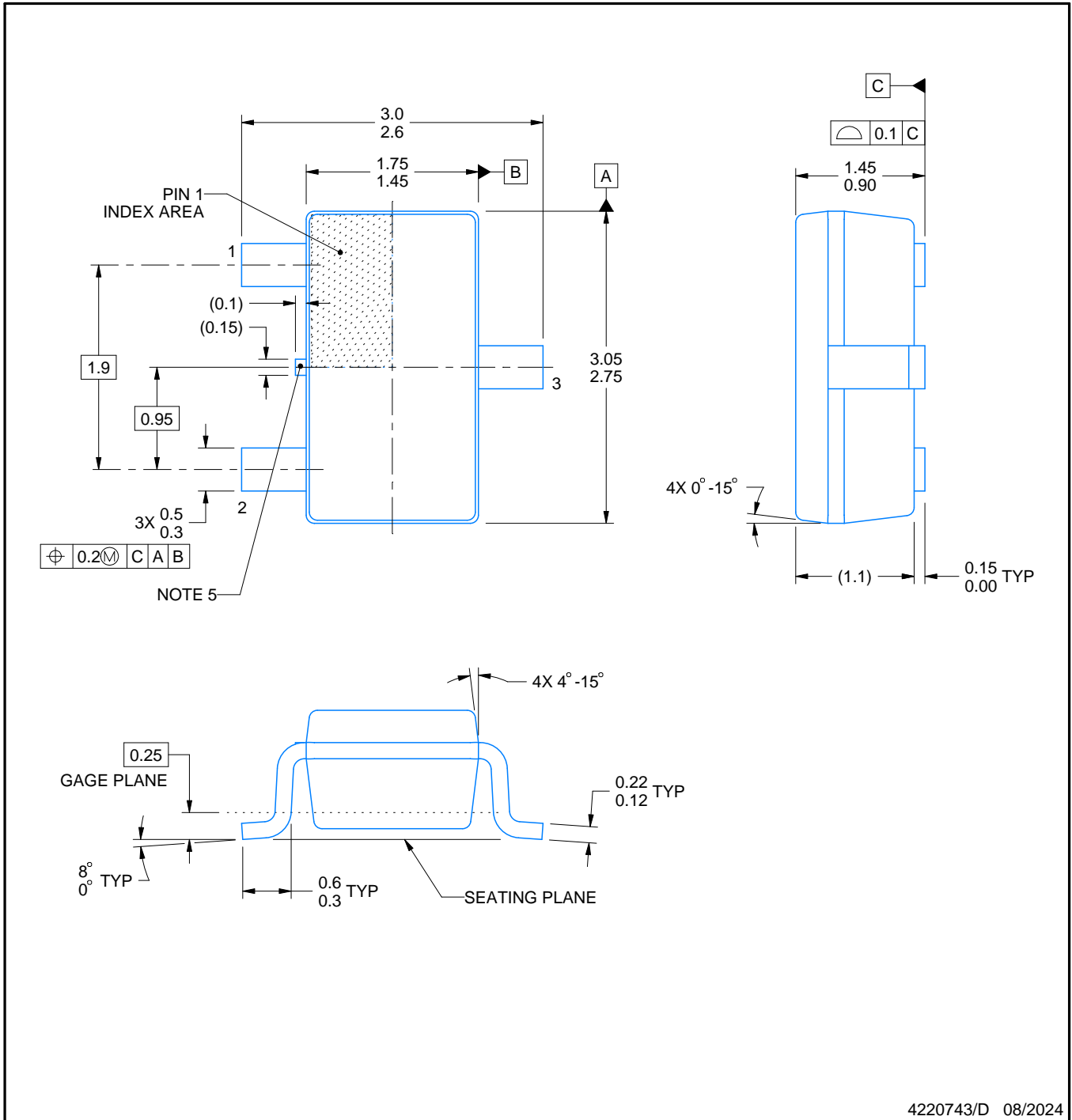

4220743/D 08/2024

NOTES:

1. All linear dimensions are in millimeters. Any dimensions in parenthesis are for reference only. Dimensioning and tolerancing per ASME Y14.5M.
2. This drawing is subject to change without notice.
3. Reference JEDEC MO-178.
4. Body dimensions do not include mold flash, protrusions, or gate burrs. Mold flash, protrusions, or gate burrs shall not exceed 0.25 mm per side.
5. Support pin may differ or may not be present.

EXAMPLE BOARD LAYOUT

DBV0003A

SOT-23 - 1.45 mm max height

SMALL OUTLINE TRANSISTOR

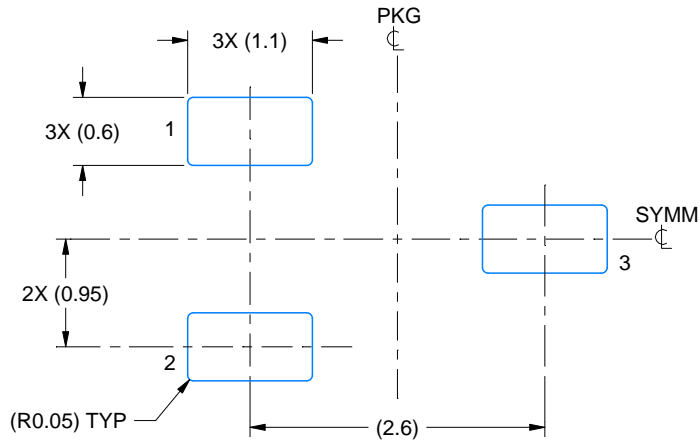

LAND PATTERN EXAMPLE
EXPOSED METAL SHOWN
SCALE:15X

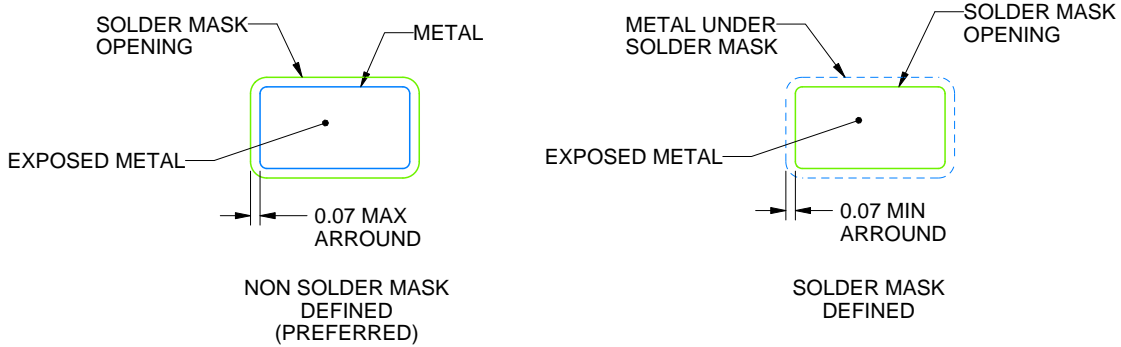

SOLDER MASK DETAILS

4220743/D 08/2024

NOTES: (continued)

- 6. Publication IPC-7351 may have alternate designs.
- 7. Solder mask tolerances between and around signal pads can vary based on board fabrication site.

EXAMPLE STENCIL DESIGN

DBV0003A

SOT-23 - 1.45 mm max height

SMALL OUTLINE TRANSISTOR

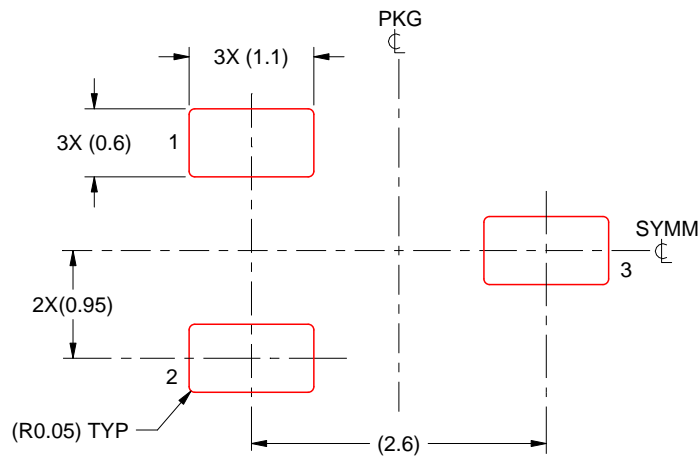

SOLDER PASTE EXAMPLE
BASED ON 0.125 mm THICK STENCIL
SCALE:15X

4220743/D 08/2024

NOTES: (continued)

8. Laser cutting apertures with trapezoidal walls and rounded corners may offer better paste release. IPC-7525 may have alternate design recommendations.
9. Board assembly site may have different recommendations for stencil design.

重要通知和免责声明

TI“按原样”提供技术和可靠性数据（包括数据表）、设计资源（包括参考设计）、应用或其他设计建议、网络工具、安全信息和其他资源，不保证没有瑕疵且不做任何明示或暗示的担保，包括但不限于对适销性、与某特定用途的适用性或不侵犯任何第三方知识产权的暗示担保。

这些资源可供使用 TI 产品进行设计的熟练开发人员使用。您将自行承担以下全部责任：(1) 针对您的应用选择合适的 TI 产品，(2) 设计、验证并测试您的应用，(3) 确保您的应用满足相应标准以及任何其他安全、安保法规或其他要求。

这些资源如有变更，恕不另行通知。TI 授权您仅可将这些资源用于研发本资源所述的 TI 产品的相关应用。严禁以其他方式对这些资源进行复制或展示。您无权使用任何其他 TI 知识产权或任何第三方知识产权。对于因您对这些资源的使用而对 TI 及其代表造成的任何索赔、损害、成本、损失和债务，您将全额赔偿，TI 对此概不负责。

TI 提供的产品受 [TI 销售条款](#)、[TI 通用质量指南](#) 或 [ti.com](#) 上其他适用条款或 TI 产品随附的其他适用条款的约束。TI 提供这些资源并不会扩展或以其他方式更改 TI 针对 TI 产品发布的适用的担保或担保免责声明。除非德州仪器 (TI) 明确将某产品指定为定制产品或客户特定产品，否则其产品均为按确定价格收入目录的标准通用器件。

TI 反对并拒绝您可能提出的任何其他或不同的条款。

版权所有 © 2025，德州仪器 (TI) 公司

最后更新日期：2025 年 10 月