

TMUX7219-Q1 具有 1.8V 逻辑电平和闩锁效应抑制特性的 44V 2:1 (SPDT) 精密开关

1 特性

- 符合面向汽车应用的 AEC-Q100 标准
 - 器件温度等级 1：-40°C 至 125°C 环境工作温度范围
- 功能安全型
 - 可提供用于功能安全系统设计的文档
- 闩锁效应抑制
- 双电源电压范围：±4.5V 至 ±22V
- 单电源电压范围：4.5V 至 44V
- 低导通电阻：2.1 Ω
- 低电荷注入：-10pC
- 大电流支持：330mA (最大值)
- 兼容 1.8V 逻辑电平
- 失效防护逻辑
- 轨到轨运行
- 双向信号路径
- 先断后合开关

2 应用

- 电动汽车充电站电源模块
- 高级驾驶辅助系统 (ADAS)
- 汽车网关
- 模拟和数字多路复用/多路信号分离
- 汽车音响主机
- 远程信息处理控制单元
- 紧急呼叫 (eCall)
- 信息娱乐系统
- 车身控制模块 (BCM)
- 车身电子装置和照明
- 电池管理系统 (BMS)
- HVAC 控制器模块
- ADAS 域控制器

3 说明

TMUX7219-Q1 是一款具有闩锁效应抑制特性的互补金属氧化物半导体 (CMOS) 开关，采用单通道 2:1 (SPDT) 配置。此器件在单电源 (4.5V 至 44 V)、双电源 (±4.5V 至 ±22V) 或非对称电源 (例如 $V_{DD} = 12V$, $V_{SS} = -5V$) 供电时均能正常运行。TMUX7219-Q1 可在源极 (Sx) 和漏极 (D) 引脚上支持从 V_{SS} 到 V_{DD} 范围的双向模拟和数字信号。

可以通过控制 EN 引脚来启用或禁用 TMUX7219-Q1。当禁用时，两个信号路径开关都被关闭。当启用时，SEL 引脚可用于打开信号路径 1 (S1 至 D) 或信号路径 2 (S2 至 D)。所有逻辑控制输入均支持 1.8V 到 V_{DD} 的逻辑电平，因此，当器件在有效电源电压范围内运行时，可确保 TTL 和 CMOS 逻辑兼容性。失效防护逻辑电路允许先在控制引脚上施加电压，然后在电源引脚上施加电压，从而保护器件免受潜在的损害。

TMUX72xx 系列具有闩锁效应抑制特性，可防止器件内寄生结构之间通常由过压事件引起的大电流不良事件。闩锁状态通常会一直持续到电源轨关闭为止，并可能导致器件失效。闩锁效应抑制特性使得 TMUX72xx 系列开关和多路复用器能够在恶劣的环境中使用。

器件信息

器件型号	封装 ⁽¹⁾	本体尺寸 (标称值)
TMUX7219-Q1	VSSOP (8) DGK	3.00mm × 3.00mm
	WSON (8) RQX	3.00mm × 2.00mm

(1) 如需了解所有可用封装，请参阅数据表末尾的封装选项附录。

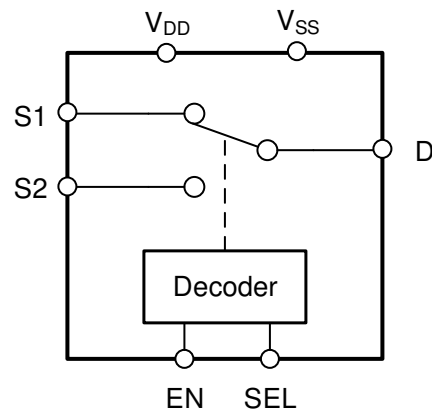

功能方框图



Table of Contents

1 特性	1	6.9 Charge Injection.....	28
2 应用	1	6.10 Off Isolation.....	28
3 说明	1	6.11 Crosstalk.....	29
4 Pin Configuration and Functions	3	6.12 Bandwidth.....	29
5 Specifications	4	6.13 THD + Noise.....	30
5.1 Absolute Maximum Ratings.....	4	6.14 Power Supply Rejection Ratio (PSRR).....	30
5.2 ESD Ratings.....	4	7 Detailed Description	31
5.3 Thermal Information.....	4	7.1 Overview.....	31
5.4 Recommended Operating Conditions.....	5	7.2 Functional Block Diagram.....	31
5.5 Source or Drain Continuous Current.....	5	7.3 Feature Description.....	31
5.6 ±15 V Dual Supply: Electrical Characteristics	6	7.4 Device Functional Modes.....	34
5.7 ±15 V Dual Supply: Switching Characteristics	7	7.5 Truth Tables.....	34
5.8 ±20 V Dual Supply: Electrical Characteristics.....	9	8 Application and Implementation	35
5.9 ±20 V Dual Supply: Switching Characteristics.....	10	8.1 Application Information.....	35
5.10 44 V Single Supply: Electrical Characteristics	12	8.2 Typical Applications.....	35
5.11 44 V Single Supply: Switching Characteristics	13	8.3 Power Supply Recommendations.....	36
5.12 12 V Single Supply: Electrical Characteristics	15	8.4 Layout.....	36
5.13 12 V Single Supply: Switching Characteristics	16	9 Device and Documentation Support	38
5.14 Typical Characteristics.....	18	9.1 Documentation Support.....	38
6 Parameter Measurement Information	24	9.2 Receiving Notification of Documentation Updates....	38
6.1 On-Resistance.....	24	9.3 支持资源.....	38
6.2 Off-Leakage Current.....	24	9.4 Trademarks.....	38
6.3 On-Leakage Current.....	25	9.5 静电放电警告.....	38
6.4 Transition Time.....	25	9.6 术语表.....	38
6.5 $t_{ON(EN)}$ and $t_{OFF(EN)}$	26	10 Revision History	38
6.6 Break-Before-Make.....	26	11 Mechanical, Packaging, and Orderable Information	39
6.7 $t_{ON(VDD)}$ Time.....	27		
6.8 Propagation Delay.....	27		

4 Pin Configuration and Functions



图 4-1. DGK Package, 8-Pin VSSOP (Top View)



图 4-2. RQX Package, 8-Pin WSON (Top View)

表 4-1. Pin Functions

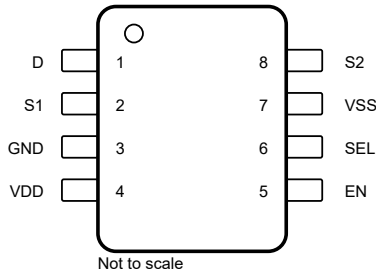
PIN			TYPE ⁽¹⁾	DESCRIPTION ⁽²⁾
NAME	RQX	DGK		
D	1	1	I/O	Drain pin. Can be an input or output.
S1	2	2	I/O	Source pin 1. Can be an input or output.
GND	3	3	P	Ground (0 V) reference
V _{DD}	4	4	P	Positive power supply. This pin is the most positive power-supply potential. For reliable operation, connect a decoupling capacitor ranging from 0.1 μ F to 10 μ F between V _{DD} and GND.
EN	5	5	I	Active high logic enable, has internal pull-up resistor. When this pin is low, all switches are turned off. When this pin is high, the SEL logic input determine which switch is turned on.
SEL	6	6	I	Logic control input, has internal pull-down resistor. Controls the switch connection as shown in 节 7.5.
V _{SS}	7	7	P	Negative power supply. This pin is the most negative power-supply potential. In single-supply applications, this pin can be connected to ground. For reliable operation, connect a decoupling capacitor ranging from 0.1 μ F to 10 μ F between V _{SS} and GND.
S2	8	8	I/O	Source pin 2. Can be an input or output.
Thermal Pad	—	—	—	The thermal pad is not connected internally. There is no requirement to electrically connect this pad. If connected, it is recommended that the pad be left floating or tied to GND.

(1) I = input, O = output, I/O = input and output, P = power.

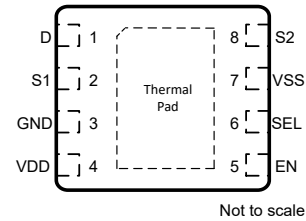
(2) Refer to 节 7.4 for what to do with unused pins.

5 Specifications

5.1 Absolute Maximum Ratings

over operating free-air temperature range (unless otherwise noted)^{(1) (2)}

		MIN	MAX	UNIT
V _{DD} - V _{SS}	Supply voltage		48	V
V _{DD}		- 0.5	48	V
V _{SS}		- 48	0.5	V
V _{SEL} or V _{EN}	Logic control input pin voltage (SEL, EN) ⁽³⁾	- 0.5	48	V
I _{SEL} or I _{EN}	Logic control input pin current (SEL, EN) ⁽³⁾	- 30	30	mA
V _S or V _D	Source or drain voltage (Sx, D) ⁽³⁾	V _{SS} - 0.5	V _{DD} +0.5	V
I _{IK}	Diode clamp current ⁽³⁾	- 30	30	mA
I _S or I _{D (CONT)}	Source or drain continuous current (Sx, D)		I _{DC} + 10 % ⁽⁴⁾	mA
T _A	Ambient temperature	- 55	150	°C
T _{stg}	Storage temperature	- 65	150	°C
T _J	Junction temperature		150	°C
P _{tot}	Total power dissipation ⁽⁵⁾		460	mW

- (1) Stresses beyond those listed under *Absolute Maximum Rating* may cause permanent damage to the device. These are stress ratings only, which do not imply functional operation of the device at these or any other conditions beyond those indicated under *Recommended Operating Condition*. Exposure to absolute-maximum-rated conditions for extended periods may affect device reliability.
- (2) All voltages are with respect to ground, unless otherwise specified.
- (3) Pins are diode-clamped to the power-supply rails. Over voltage signals must be voltage and current limited to maximum ratings.
- (4) Refer to *Source or Drain Continuous Current* table for I_{DC} specifications.
- (5) For DGK package: P_{tot} derates linearly above T_A = 70°C by 6.7mW/°C.

5.2 ESD Ratings

			VALUE	UNIT
V _(ESD)	Electrostatic discharge	Human body model (HBM), per ANSI/ESDA/ JEDEC JS-001, all pins ⁽¹⁾	±2000	V
		Charged device model (CDM), per JEDEC specification JESD22-C101, all pins ⁽²⁾	±500	

- (1) JEDEC document JEP155 states that 500-V HBM allows safe manufacturing with a standard ESD control process.
- (2) JEDEC document JEP157 states that 250-V CDM allows safe manufacturing with a standard ESD control process.

5.3 Thermal Information

THERMAL METRIC ⁽¹⁾		TMUX7219-Q1	UNIT
		DGK (VSSOP)	
		8 PINS	
R _{θJA}	Junction-to-ambient thermal resistance	152.1	°C/W
R _{θJC(top)}	Junction-to-case (top) thermal resistance	48.4	°C/W
R _{θJB}	Junction-to-board thermal resistance	73.2	°C/W
Ψ _{JT}	Junction-to-top characterization parameter	4.1	°C/W
Ψ _{JB}	Junction-to-board characterization parameter	71.8	°C/W
R _{θJC(bot)}	Junction-to-case (bottom) thermal resistance	N/A	°C/W

- (1) For more information about traditional and new thermal metrics, see the [Semiconductor and IC Package Thermal Metrics](#) application report.

5.4 Recommended Operating Conditions

over operating free-air temperature range (unless otherwise noted)

		MIN	NOM	MAX	UNIT
$V_{DD} - V_{SS}$ ⁽¹⁾	Power supply voltage differential	4.5		44	V
V_{DD}	Positive power supply voltage	4.5		44	V
V_S or V_D	Signal path input/output voltage (source or drain pin) (Sx, D)	V_{SS}		V_{DD}	V
V_{SEL} or V_{EN}	Address or enable pin voltage	0		44	V
I_S or I_D (CONT)	Source or drain continuous current (Sx, D)			I_{DC} ⁽²⁾	mA
T_A	Ambient temperature	- 40		125	°C

(1) V_{DD} and V_{SS} can be any value as long as $4.5\text{ V} \leq (V_{DD} - V_{SS}) \leq 44\text{ V}$, and the minimum V_{DD} is met.

(2) Refer to *Source or Drain Continuous Current* table for I_{DC} specifications.

5.5 Source or Drain Continuous Current

at supply voltage of $V_{DD} \pm 10\%$, $V_{SS} \pm 10\%$ (unless otherwise noted)

CONTINUOUS CURRENT PER CHANNEL (I_{DC})		$T_A = 25^\circ\text{C}$	$T_A = 85^\circ\text{C}$	$T_A = 125^\circ\text{C}$	UNIT
PACKAGE	TEST CONDITIONS				
DGK (VSSOP)	+44 V Single Supply ⁽¹⁾	330	210	120	mA
	$\pm 15\text{ V}$ Dual Supply	330	210	120	mA
	+12 V Single Supply	240	160	100	mA
	$\pm 5\text{ V}$ Dual Supply	240	160	100	mA
	+5 V Single Supply	180	120	80	mA

(1) Specified for nominal supply voltage only.

5.6 ±15 V Dual Supply: Electrical Characteristics

V_{DD} = +15 V ± 10%, V_{SS} = - 15 V ± 10%, GND = 0 V (unless otherwise noted)

Typical at V_{DD} = +15 V, V_{SS} = - 15 V, T_A = 25°C (unless otherwise noted)

PARAMETER		TEST CONDITIONS	T _A	MIN	TYP	MAX	UNIT	
ANALOG SWITCH								
R _{ON}	On-resistance	V _S = - 10 V to +10 V I _D = - 10 mA Refer to On-Resistance	25°C		2.1	2.9	Ω	
			- 40°C to +85°C			3.8	Ω	
			- 40°C to +125°C			4.5	Ω	
Δ R _{ON}	On-resistance mismatch between channels	V _S = - 10 V to +10 V I _D = - 10 mA Refer to On-Resistance	25°C		0.05	0.25	Ω	
			- 40°C to +85°C			0.3	Ω	
			- 40°C to +125°C			0.35	Ω	
R _{ON FLAT}	On-resistance flatness	V _S = - 10 V to +10 V I _S = - 10 mA Refer to On-Resistance	25°C		0.5	0.6	Ω	
			- 40°C to +85°C			0.7	Ω	
			- 40°C to +125°C			0.85	Ω	
R _{ON DRIFT}	On-resistance drift	V _S = 0 V, I _S = - 10 mA Refer to On-Resistance	- 40°C to +125°C		0.01		Ω/°C	
I _{S(OFF)}	Source off leakage current ⁽¹⁾	V _{DD} = 16.5 V, V _{SS} = - 16.5 V Switch state is off V _S = +10 V / - 10 V V _D = - 10 V / + 10 V Refer to Off-Leakage Current	25°C	- 0.2	0.1	0.2	nA	
			- 40°C to +85°C		- 2		2	nA
			- 40°C to +125°C		- 25		25	nA
I _{D(OFF)}	Drain off leakage current ⁽¹⁾	V _{DD} = 16.5 V, V _{SS} = - 16.5 V Switch state is off V _S = +10 V / - 10 V V _D = - 10 V / + 10 V Refer to Off-Leakage Current	25°C	- 2	0.1	2	nA	
			- 40°C to +85°C		- 4		4	nA
			- 40°C to +125°C		- 60		60	nA
I _{S(ON)} I _{D(ON)}	Channel on leakage current ⁽²⁾	V _{DD} = 16.5 V, V _{SS} = - 16.5 V Switch state is on V _S = V _D = ±10 V Refer to On-Leakage Current	25°C	- 2	0.1	2	nA	
			- 40°C to +85°C		- 4		4	nA
			- 40°C to +125°C		- 60		60	nA
LOGIC INPUTS (SEL / EN pins)								
V _{IH}	Logic voltage high		- 40°C to +125°C	1.3		44	V	
V _{IL}	Logic voltage low		- 40°C to +125°C	0		0.8	V	
I _{IH}	Input leakage current		- 40°C to +125°C		0.005	2	μA	
I _{IL}	Input leakage current		- 40°C to +125°C	- 1	- 0.005		μA	
C _{IN}	Logic input capacitance		- 40°C to +125°C		3		pF	
POWER SUPPLY								
I _{DD}	V _{DD} supply current	V _{DD} = 16.5 V, V _{SS} = - 16.5 V Logic inputs = 0 V, 5 V, or V _{DD}	25°C		30	40	μA	
			- 40°C to +85°C			48	μA	
			- 40°C to +125°C			62	μA	
I _{SS}	V _{SS} supply current	V _{DD} = 16.5 V, V _{SS} = - 16.5 V Logic inputs = 0 V, 5 V, or V _{DD}	25°C		3	10	μA	
			- 40°C to +85°C			15	μA	
			- 40°C to +125°C			25	μA	

(1) When V_S is positive, V_D is negative, or when V_S is negative, V_D is positive.

(2) When V_S is at a voltage potential, V_D is floating, or when V_D is at a voltage potential, V_S is floating.

5.7 ±15 V Dual Supply: Switching Characteristics

$V_{DD} = +15\text{ V} \pm 10\%$, $V_{SS} = -15\text{ V} \pm 10\%$, $GND = 0\text{ V}$ (unless otherwise noted)

Typical at $V_{DD} = +15\text{ V}$, $V_{SS} = -15\text{ V}$, $T_A = 25^\circ\text{C}$ (unless otherwise noted)

PARAMETER		TEST CONDITIONS	T_A	MIN	TYP	MAX	UNIT
t_{TRAN}	Transition time from control input	$V_S = 10\text{ V}$ $R_L = 300\ \Omega$, $C_L = 35\text{ pF}$ Refer to Transition Time	25°C		120	175	ns
			-40°C to +85°C			190	ns
			-40°C to +125°C			210	ns
$t_{\text{ON (EN)}}$	Turn-on time from enable	$V_S = 10\text{ V}$ $R_L = 300\ \Omega$, $C_L = 35\text{ pF}$ Refer to Turn-on and Turn-off Time	25°C		100	170	ns
			-40°C to +85°C			185	ns
			-40°C to +125°C			200	ns
$t_{\text{OFF (EN)}}$	Turn-off time from enable	$V_S = 10\text{ V}$ $R_L = 300\ \Omega$, $C_L = 35\text{ pF}$ Refer to Turn-on and Turn-off Time	25°C		100	180	ns
			-40°C to +85°C			195	ns
			-40°C to +125°C			210	ns
t_{BBM}	Break-before-make time delay	$V_S = 10\text{ V}$, $R_L = 300\ \Omega$, $C_L = 35\text{ pF}$ Refer to Break-Before-Make	25°C		50		ns
			-40°C to +85°C		1		ns
			-40°C to +125°C		1		ns
$T_{\text{ON (VDD)}}$	Device turn on time (V_{DD} to output)	V_{DD} rise time = 100ns $R_L = 300\ \Omega$, $C_L = 35\text{ pF}$ Refer to Turn-on (VDD) Time	25°C		0.19		ms
			-40°C to +85°C			0.2	ms
			-40°C to +125°C			0.2	ms
t_{PD}	Propagation delay	$R_L = 50\ \Omega$, $C_L = 5\text{ pF}$ Refer to Propagation Delay	25°C		700		ps
Q_{INJ}	Charge injection	$V_D = 0\text{ V}$, $C_L = 1\text{ nF}$ Refer to Charge Injection	25°C		-10		pC
O_{ISO}	Off-isolation	$R_L = 50\ \Omega$, $C_L = 5\text{ pF}$ $V_S = 0\text{ V}$, $f = 100\text{ kHz}$ Refer to Off Isolation	25°C		-75		dB
O_{ISO}	Off-isolation	$R_L = 50\ \Omega$, $C_L = 5\text{ pF}$ $V_S = 0\text{ V}$, $f = 1\text{ MHz}$ Refer to Off Isolation	25°C		-55		dB
X_{TALK}	Crosstalk	$R_L = 50\ \Omega$, $C_L = 5\text{ pF}$ $V_S = 0\text{ V}$, $f = 100\text{ kHz}$ Refer to Crosstalk	25°C		-117		dB
X_{TALK}	Crosstalk	$R_L = 50\ \Omega$, $C_L = 5\text{ pF}$ $V_S = 0\text{ V}$, $f = 1\text{ MHz}$ Refer to Crosstalk	25°C		-106		dB
BW	-3dB Bandwidth	$R_L = 50\ \Omega$, $C_L = 5\text{ pF}$ $V_S = 0\text{ V}$ Refer to Bandwidth	25°C		40		MHz
I_L	Insertion loss	$R_L = 50\ \Omega$, $C_L = 5\text{ pF}$ $V_S = 0\text{ V}$, $f = 1\text{ MHz}$	25°C		-0.18		dB
ACPSRR	AC Power Supply Rejection Ratio	$V_{PP} = 0.62\text{ V}$ on V_{DD} and V_{SS} $R_L = 50\ \Omega$, $C_L = 5\text{ pF}$, $f = 1\text{ MHz}$ Refer to ACPSRR	25°C		-64		dB
THD+N	Total Harmonic Distortion + Noise	$V_{PP} = 15\text{ V}$, $V_{BIAS} = 0\text{ V}$ $R_L = 10\text{ k}\Omega$, $C_L = 5\text{ pF}$, $f = 20\text{ Hz}$ to 20 kHz Refer to THD + Noise	25°C		0.0005		%
$C_{S(\text{OFF})}$	Source off capacitance	$V_S = 0\text{ V}$, $f = 1\text{ MHz}$	25°C		33		pF
$C_{D(\text{OFF})}$	Drain off capacitance	$V_S = 0\text{ V}$, $f = 1\text{ MHz}$	25°C		48		pF

$V_{DD} = +15\text{ V} \pm 10\%$, $V_{SS} = -15\text{ V} \pm 10\%$, GND = 0 V (unless otherwise noted)

Typical at $V_{DD} = +15\text{ V}$, $V_{SS} = -15\text{ V}$, $T_A = 25^\circ\text{C}$ (unless otherwise noted)

PARAMETER		TEST CONDITIONS	T_A	MIN	TYP	MAX	UNIT
$C_{S(ON)}$, $C_{D(ON)}$	On capacitance	$V_S = 0\text{ V}$, $f = 1\text{ MHz}$	25°C		148		pF

5.8 ±20 V Dual Supply: Electrical Characteristics

$V_{DD} = +20\text{ V} \pm 10\%$, $V_{SS} = -20\text{ V} \pm 10\%$, $GND = 0\text{ V}$ (unless otherwise noted)

Typical at $V_{DD} = +20\text{ V}$, $V_{SS} = -20\text{ V}$, $T_A = 25^\circ\text{C}$ (unless otherwise noted)

PARAMETER		TEST CONDITIONS	T_A	MIN	TYP	MAX	UNIT	
ANALOG SWITCH								
R_{ON}	On-resistance	$V_S = -15\text{ V to }+15\text{ V}$ $I_D = -10\text{ mA}$ Refer to On-Resistance	25°C	1.9	2.7		Ω	
			-40°C to +85°C			3.5	Ω	
			-40°C to +125°C			4.2	Ω	
ΔR_{ON}	On-resistance mismatch between channels	$V_S = -15\text{ V to }+15\text{ V}$ $I_D = -10\text{ mA}$ Refer to On-Resistance	25°C	0.04	0.22		Ω	
			-40°C to +85°C			0.28	Ω	
			-40°C to +125°C			0.3	Ω	
$R_{ON\ FLAT}$	On-resistance flatness	$V_S = -15\text{ V to }+15\text{ V}$ $I_S = -10\text{ mA}$ Refer to On-Resistance	25°C	0.3	0.75		Ω	
			-40°C to +85°C			0.9	Ω	
			-40°C to +125°C			1.2	Ω	
$R_{ON\ DRIFT}$	On-resistance drift	$V_S = 0\text{ V}$, $I_S = -10\text{ mA}$ Refer to On-Resistance	-40°C to +125°C	0.009			$\Omega/^\circ\text{C}$	
$I_{S(OFF)}$	Source off leakage current ⁽¹⁾	$V_{DD} = 22\text{ V}$, $V_{SS} = -22\text{ V}$ Switch state is off $V_S = +15\text{ V} / -15\text{ V}$ $V_D = -15\text{ V} / +15\text{ V}$ Refer to Off-Leakage Current	25°C	-2	0.1	2	nA	
			-40°C to +85°C				5	nA
			-40°C to +125°C				30	nA
$I_{D(OFF)}$	Drain off leakage current ⁽¹⁾	$V_{DD} = 22\text{ V}$, $V_{SS} = -22\text{ V}$ Switch state is off $V_S = +15\text{ V} / -15\text{ V}$ $V_D = -15\text{ V} / +15\text{ V}$ Refer to Off-Leakage Current	25°C	-3	0.1	3	nA	
			-40°C to +85°C				10	nA
			-40°C to +125°C				70	nA
$I_{S(ON)}$ $I_{D(ON)}$	Channel on leakage current ⁽²⁾	$V_{DD} = 22\text{ V}$, $V_{SS} = -22\text{ V}$ Switch state is on $V_S = V_D = \pm 15\text{ V}$ Refer to On-Leakage Current	25°C	-3	0.1	3	nA	
			-40°C to +85°C				10	nA
			-40°C to +125°C				70	nA
LOGIC INPUTS (SEL / EN pins)								
V_{IH}	Logic voltage high		-40°C to +125°C	1.3		44	V	
V_{IL}	Logic voltage low		-40°C to +125°C	0		0.8	V	
I_{IH}	Input leakage current		-40°C to +125°C		0.005	2	μA	
I_{IL}	Input leakage current		-40°C to +125°C	-1	-0.005		μA	
C_{IN}	Logic input capacitance		-40°C to +125°C		3		pF	
POWER SUPPLY								
I_{DD}	V_{DD} supply current	$V_{DD} = 22\text{ V}$, $V_{SS} = -22\text{ V}$ Logic inputs = 0 V, 5 V, or V_{DD}	25°C	34	44		μA	
			-40°C to +85°C			50	μA	
			-40°C to +125°C			65	μA	
I_{SS}	V_{SS} supply current	$V_{DD} = 22\text{ V}$, $V_{SS} = -22\text{ V}$ Logic inputs = 0 V, 5 V, or V_{DD}	25°C	4	9		μA	
			-40°C to +85°C			12	μA	
			-40°C to +125°C			25	μA	

(1) When V_S is positive, V_D is negative, or when V_S is negative, V_D is positive.

(2) When V_S is at a voltage potential, V_D is floating, or when V_D is at a voltage potential, V_S is floating.

5.9 ±20 V Dual Supply: Switching Characteristics

$V_{DD} = +20\text{ V} \pm 10\%$, $V_{SS} = -20\text{ V} \pm 10\%$, $GND = 0\text{ V}$ (unless otherwise noted)

Typical at $V_{DD} = +20\text{ V}$, $V_{SS} = -20\text{ V}$, $T_A = 25^\circ\text{C}$ (unless otherwise noted)

PARAMETER		TEST CONDITIONS	T_A	MIN	TYP	MAX	UNIT
t_{TRAN}	Transition time from control input	$V_S = 10\text{ V}$ $R_L = 300\ \Omega$, $C_L = 35\text{ pF}$ Refer to Transition Time	25°C		110	175	ns
			-40°C to +85°C			190	ns
			-40°C to +125°C			205	ns
$t_{\text{ON (EN)}}$	Turn-on time from enable	$V_S = 10\text{ V}$ $R_L = 300\ \Omega$, $C_L = 35\text{ pF}$ Refer to Turn-on and Turn-off Time	25°C		110	170	ns
			-40°C to +85°C			185	ns
			-40°C to +125°C			200	ns
$t_{\text{OFF (EN)}}$	Turn-off time from enable	$V_S = 10\text{ V}$ $R_L = 300\ \Omega$, $C_L = 35\text{ pF}$ Refer to Turn-on and Turn-off Time	25°C		90	180	ns
			-40°C to +85°C			190	ns
			-40°C to +125°C			200	ns
t_{BBM}	Break-before-make time delay	$V_S = 10\text{ V}$, $R_L = 300\ \Omega$, $C_L = 35\text{ pF}$ Refer to Break-Before-Make	25°C		55		ns
			-40°C to +85°C		1		ns
			-40°C to +125°C		1		ns
$T_{\text{ON (VDD)}}$	Device turn on time (V_{DD} to output)	V_{DD} rise time = 100ns $R_L = 300\ \Omega$, $C_L = 35\text{ pF}$ Refer to Turn-on (VDD) Time	25°C		0.18		ms
			-40°C to +85°C			0.2	ms
			-40°C to +125°C			0.2	ms
t_{PD}	Propagation delay	$R_L = 50\ \Omega$, $C_L = 5\text{ pF}$ Refer to Propagation Delay	25°C		715		ps
Q_{INJ}	Charge injection	$V_D = 0\text{ V}$, $C_L = 1\text{ nF}$ Refer to Charge Injection	25°C		-15		pC
O_{ISO}	Off-isolation	$R_L = 50\ \Omega$, $C_L = 5\text{ pF}$ $V_S = 0\text{ V}$, $f = 100\text{ kHz}$ Refer to Off Isolation	25°C		-75		dB
O_{ISO}	Off-isolation	$R_L = 50\ \Omega$, $C_L = 5\text{ pF}$ $V_S = 0\text{ V}$, $f = 1\text{ MHz}$ Refer to Off Isolation	25°C		-55		dB
X_{TALK}	Crosstalk	$R_L = 50\ \Omega$, $C_L = 5\text{ pF}$ $V_S = 0\text{ V}$, $f = 100\text{ kHz}$ Refer to Crosstalk	25°C		-117		dB
X_{TALK}	Crosstalk	$R_L = 50\ \Omega$, $C_L = 5\text{ pF}$ $V_S = 0\text{ V}$, $f = 1\text{ MHz}$ Refer to Crosstalk	25°C		-106		dB
BW	-3dB Bandwidth	$R_L = 50\ \Omega$, $C_L = 5\text{ pF}$ $V_S = 0\text{ V}$, Refer to Bandwidth	25°C		38		MHz
I_L	Insertion loss	$R_L = 50\ \Omega$, $C_L = 5\text{ pF}$ $V_S = 0\text{ V}$, $f = 1\text{ MHz}$	25°C		-0.16		dB
ACPSRR	AC Power Supply Rejection Ratio	$V_{PP} = 0.62\text{ V}$ on V_{DD} and V_{SS} $R_L = 50\ \Omega$, $C_L = 5\text{ pF}$, $f = 1\text{ MHz}$ Refer to ACPSRR	25°C		-63		dB
THD+N	Total Harmonic Distortion + Noise	$V_{PP} = 20\text{ V}$, $V_{BIAS} = 0\text{ V}$ $R_L = 10\text{ k}\Omega$, $C_L = 5\text{ pF}$, $f = 20\text{ Hz}$ to 20 kHz Refer to THD + Noise	25°C		0.0005		%
$C_{S(\text{OFF})}$	Source off capacitance	$V_S = 0\text{ V}$, $f = 1\text{ MHz}$	25°C		32		pF
$C_{D(\text{OFF})}$	Drain off capacitance	$V_S = 0\text{ V}$, $f = 1\text{ MHz}$	25°C		45		pF

$V_{DD} = +20\text{ V} \pm 10\%$, $V_{SS} = -20\text{ V} \pm 10\%$, $GND = 0\text{ V}$ (unless otherwise noted)

Typical at $V_{DD} = +20\text{ V}$, $V_{SS} = -20\text{ V}$, $T_A = 25^\circ\text{C}$ (unless otherwise noted)

PARAMETER		TEST CONDITIONS	T_A	MIN	TYP	MAX	UNIT
$C_{S(ON)}$, $C_{D(ON)}$	On capacitance	$V_S = 0\text{ V}$, $f = 1\text{ MHz}$	25°C		146		pF

5.10 44 V Single Supply: Electrical Characteristics

$V_{DD} = +44\text{ V}$, $V_{SS} = 0\text{ V}$, $GND = 0\text{ V}$ (unless otherwise noted)

Typical at $V_{DD} = +44\text{ V}$, $V_{SS} = 0\text{ V}$, $T_A = 25^\circ\text{C}$ (unless otherwise noted)

PARAMETER		TEST CONDITIONS	T_A	MIN	TYP	MAX	UNIT	
ANALOG SWITCH								
R_{ON}	On-resistance	$V_S = 0\text{ V to }40\text{ V}$ $I_D = -10\text{ mA}$ Refer to On-Resistance	25°C		2.2	2.8	Ω	
			-40°C to +85°C			3.6	Ω	
			-40°C to +125°C			4.2	Ω	
ΔR_{ON}	On-resistance mismatch between channels	$V_S = 0\text{ V to }40\text{ V}$ $I_D = -10\text{ mA}$ Refer to On-Resistance	25°C		0.1	0.2	Ω	
			-40°C to +85°C			0.3	Ω	
			-40°C to +125°C			0.35	Ω	
$R_{ON\ FLAT}$	On-resistance flatness	$V_S = 0\text{ V to }40\text{ V}$ $I_D = -10\text{ mA}$ Refer to On-Resistance	25°C		0.2	1	Ω	
			-40°C to +85°C			1.3	Ω	
			-40°C to +125°C			1.5	Ω	
$R_{ON\ DRIFT}$	On-resistance drift	$V_S = 22\text{ V}$, $I_S = -10\text{ mA}$ Refer to On-Resistance	-40°C to +125°C		0.008		$\Omega/^\circ\text{C}$	
$I_{S(OFF)}$	Source off leakage current ⁽¹⁾	$V_{DD} = 44\text{ V}$, $V_{SS} = 0\text{ V}$ Switch state is off $V_S = 40\text{ V} / 1\text{ V}$ $V_D = 1\text{ V} / 40\text{ V}$ Refer to Off-Leakage Current	25°C	-8	0.1	8	nA	
			-40°C to +85°C		-12		12	nA
			-40°C to +125°C		-40		40	nA
$I_{D(OFF)}$	Drain off leakage current ⁽¹⁾	$V_{DD} = 44\text{ V}$, $V_{SS} = 0\text{ V}$ Switch state is off $V_S = 40\text{ V} / 1\text{ V}$ $V_D = 1\text{ V} / 40\text{ V}$ Refer to Off-Leakage Current	25°C	-10	0.1	10	nA	
			-40°C to +85°C		-15		15	nA
			-40°C to +125°C		-100		100	nA
$I_{S(ON)}$ $I_{D(ON)}$	Channel on leakage current ⁽²⁾	$V_{DD} = 44\text{ V}$, $V_{SS} = 0\text{ V}$ Switch state is on $V_S = V_D = 40\text{ V or }1\text{ V}$ Refer to On-Leakage Current	25°C	-10	0.1	10	nA	
			-40°C to +85°C		-15		15	nA
			-40°C to +125°C		-100		100	nA
LOGIC INPUTS (SEL / EN pins)								
V_{IH}	Logic voltage high		-40°C to +125°C	1.3		44	V	
V_{IL}	Logic voltage low		-40°C to +125°C	0		0.8	V	
I_{IH}	Input leakage current		-40°C to +125°C		0.005	2	μA	
I_{IL}	Input leakage current		-40°C to +125°C	-1	-0.005		μA	
C_{IN}	Logic input capacitance		-40°C to +125°C		3		pF	
POWER SUPPLY								
I_{DD}	V_{DD} supply current	$V_{DD} = 44\text{ V}$, $V_{SS} = 0\text{ V}$ Logic inputs = 0 V, 5 V, or V_{DD}	25°C		17	50	μA	
			-40°C to +85°C			60	μA	
			-40°C to +125°C			75	μA	

(1) When V_S is positive, V_D is negative, or when V_S is negative, V_D is positive.

(2) When V_S is at a voltage potential, V_D is floating, or when V_D is at a voltage potential, V_S is floating.

5.11 44 V Single Supply: Switching Characteristics

$V_{DD} = +44\text{ V}$, $V_{SS} = 0\text{ V}$, $GND = 0\text{ V}$ (unless otherwise noted)

Typical at $V_{DD} = +44\text{ V}$, $V_{SS} = 0\text{ V}$, $T_A = 25^\circ\text{C}$ (unless otherwise noted)

PARAMETER		TEST CONDITIONS	T_A	MIN	TYP	MAX	UNIT
t_{TRAN}	Transition time from control input	$V_S = 18\text{ V}$ $R_L = 300\ \Omega$, $C_L = 35\text{ pF}$ Refer to Transition Time	25°C		120	175	ns
			-40°C to +85°C			190	ns
			-40°C to +125°C			205	ns
$t_{\text{ON (EN)}}$	Turn-on time from enable	$V_S = 18\text{ V}$ $R_L = 300\ \Omega$, $C_L = 35\text{ pF}$ Refer to Turn-on and Turn-off Time	25°C		120	168	ns
			-40°C to +85°C			185	ns
			-40°C to +125°C			195	ns
$t_{\text{OFF (EN)}}$	Turn-off time from enable	$V_S = 18\text{ V}$ $R_L = 300\ \Omega$, $C_L = 35\text{ pF}$ Refer to Turn-on and Turn-off Time	25°C		120	180	ns
			-40°C to +85°C			200	ns
			-40°C to +125°C			205	ns
t_{BBM}	Break-before-make time delay	$V_S = 18\text{ V}$, $R_L = 300\ \Omega$, $C_L = 35\text{ pF}$ Refer to Break-Before-Make	25°C		45		ns
			-40°C to +85°C		1		ns
			-40°C to +125°C		1		ns
$T_{\text{ON (VDD)}}$	Device turn on time (V_{DD} to output)	V_{DD} rise time = 1 μs $R_L = 300\ \Omega$, $C_L = 35\text{ pF}$ Refer to Turn-on (VDD) Time	25°C		0.15		ms
			-40°C to +85°C			0.17	ms
			-40°C to +125°C			0.17	ms
t_{PD}	Propagation delay	$R_L = 50\ \Omega$, $C_L = 5\text{ pF}$ Refer to Propagation Delay	25°C		930		ps
Q_{INJ}	Charge injection	$V_D = 22\text{ V}$, $C_L = 1\text{ nF}$ Refer to Charge Injection	25°C		-16		pC
O_{ISO}	Off-isolation	$R_L = 50\ \Omega$, $C_L = 5\text{ pF}$ $V_S = 6\text{ V}$, $f = 100\text{ kHz}$ Refer to Off Isolation	25°C		-75		dB
O_{ISO}	Off-isolation	$R_L = 50\ \Omega$, $C_L = 5\text{ pF}$ $V_S = 6\text{ V}$, $f = 1\text{ MHz}$ Refer to Off Isolation	25°C		-55		dB
X_{TALK}	Crosstalk	$R_L = 50\ \Omega$, $C_L = 5\text{ pF}$ $V_S = 6\text{ V}$, $f = 100\text{ kHz}$ Refer to Crosstalk	25°C		-117		dB
X_{TALK}	Crosstalk	$R_L = 50\ \Omega$, $C_L = 5\text{ pF}$ $V_S = 6\text{ V}$, $f = 1\text{ MHz}$ Refer to Crosstalk	25°C		-106		dB
BW	-3dB Bandwidth	$R_L = 50\ \Omega$, $C_L = 5\text{ pF}$ $V_S = 6\text{ V}$ Refer to Bandwidth	25°C		37		MHz
I_L	Insertion loss	$R_L = 50\ \Omega$, $C_L = 5\text{ pF}$ $V_S = 6\text{ V}$, $f = 1\text{ MHz}$	25°C		-0.18		dB
ACPSRR	AC Power Supply Rejection Ratio	$V_{PP} = 0.62\text{ V}$ on V_{DD} and V_{SS} $R_L = 50\ \Omega$, $C_L = 5\text{ pF}$, $f = 1\text{ MHz}$ Refer to ACPSRR	25°C		-60		dB
THD+N	Total Harmonic Distortion + Noise	$V_{PP} = 22\text{ V}$, $V_{BIAS} = 22\text{ V}$ $R_L = 10\text{ k}\Omega$, $C_L = 5\text{ pF}$, $f = 20\text{ Hz}$ to 20 kHz Refer to THD + Noise	25°C		0.0004		%
$C_{\text{S(OFF)}}$	Source off capacitance	$V_S = 6\text{ V}$, $f = 1\text{ MHz}$	25°C		34		pF
$C_{\text{D(OFF)}}$	Drain off capacitance	$V_S = 6\text{ V}$, $f = 1\text{ MHz}$	25°C		48		pF

TMUX7219-Q1

ZHCSMZ0B - JANUARY 2021 - REVISED JULY 2024

 $V_{DD} = +44\text{ V}$, $V_{SS} = 0\text{ V}$, $GND = 0\text{ V}$ (unless otherwise noted)

 Typical at $V_{DD} = +44\text{ V}$, $V_{SS} = 0\text{ V}$, $T_A = 25^\circ\text{C}$ (unless otherwise noted)

PARAMETER		TEST CONDITIONS	T_A	MIN	TYP	MAX	UNIT
$C_{S(ON)}$, $C_{D(ON)}$	On capacitance	$V_S = 6\text{ V}$, $f = 1\text{ MHz}$	25°C		146		pF

5.12 12 V Single Supply: Electrical Characteristics

$V_{DD} = +12\text{ V} \pm 10\%$, $V_{SS} = 0\text{ V}$, $GND = 0\text{ V}$ (unless otherwise noted)

Typical at $V_{DD} = +12\text{ V}$, $V_{SS} = 0\text{ V}$, $T_A = 25^\circ\text{C}$ (unless otherwise noted)

PARAMETER		TEST CONDITIONS	T_A	MIN	TYP	MAX	UNIT	
ANALOG SWITCH								
R_{ON}	On-resistance	$V_S = 0\text{ V to }10\text{ V}$ $I_D = -10\text{ mA}$ Refer to On-Resistance	25°C	4.6		6	Ω	
			-40°C to +85°C			7.5	Ω	
			-40°C to +125°C			8.4	Ω	
ΔR_{ON}	On-resistance mismatch between channels	$V_S = 0\text{ V to }10\text{ V}$ $I_D = -10\text{ mA}$ Refer to On-Resistance	25°C	0.08		0.2	Ω	
			-40°C to +85°C			0.32	Ω	
			-40°C to +125°C			0.35	Ω	
$R_{ON\ FLAT}$	On-resistance flatness	$V_S = 0\text{ V to }10\text{ V}$ $I_S = -10\text{ mA}$ Refer to On-Resistance	25°C	1.2		2	Ω	
			-40°C to +85°C			2.2	Ω	
			-40°C to +125°C			2.4	Ω	
$R_{ON\ DRIFT}$	On-resistance drift	$V_S = 6\text{ V}$, $I_S = -10\text{ mA}$ Refer to On-Resistance	-40°C to +125°C		0.017		$\Omega/^\circ\text{C}$	
$I_{S(OFF)}$	Source off leakage current ⁽¹⁾	$V_{DD} = 13.2\text{ V}$, $V_{SS} = 0\text{ V}$ Switch state is off $V_S = 10\text{ V} / 1\text{ V}$ $V_D = 1\text{ V} / 10\text{ V}$ Refer to Off-Leakage Current	25°C	-1	0.1	1	nA	
			-40°C to +85°C				3	nA
			-40°C to +125°C				25	nA
$I_{D(OFF)}$	Drain off leakage current ⁽¹⁾	$V_{DD} = 13.2\text{ V}$, $V_{SS} = 0\text{ V}$ Switch state is off $V_S = 10\text{ V} / 1\text{ V}$ $V_D = 1\text{ V} / 10\text{ V}$ Refer to Off-Leakage Current	25°C	-2	0.1	2	nA	
			-40°C to +85°C				4	nA
			-40°C to +125°C				60	nA
$I_{S(ON)}$ $I_{D(ON)}$	Channel on leakage current ⁽²⁾	$V_{DD} = 13.2\text{ V}$, $V_{SS} = 0\text{ V}$ Switch state is on $V_S = V_D = 10\text{ V or }1\text{ V}$ Refer to On-Leakage Current	25°C	-2	0.1	2	nA	
			-40°C to +85°C				4	nA
			-40°C to +125°C				60	nA
LOGIC INPUTS (SEL / EN pins)								
V_{IH}	Logic voltage high		-40°C to +125°C	1.3		44	V	
V_{IL}	Logic voltage low		-40°C to +125°C	0		0.8	V	
I_{IH}	Input leakage current		-40°C to +125°C		0.005	2	μA	
I_{IL}	Input leakage current		-40°C to +125°C	-1	-0.005		μA	
C_{IN}	Logic input capacitance		-40°C to +125°C		3		pF	
POWER SUPPLY								
I_{DD}	V_{DD} supply current	$V_{DD} = 13.2\text{ V}$, $V_{SS} = 0\text{ V}$ Logic inputs = 0 V, 5 V, or V_{DD}	25°C		10	35	μA	
			-40°C to +85°C				45	μA
			-40°C to +125°C				55	μA

(1) When V_S is positive, V_D is negative, or when V_S is negative, V_D is positive.

(2) When V_S is at a voltage potential, V_D is floating, or when V_D is at a voltage potential, V_S is floating.

5.13 12 V Single Supply: Switching Characteristics

$V_{DD} = +12\text{ V} \pm 10\%$, $V_{SS} = 0\text{ V}$, $GND = 0\text{ V}$ (unless otherwise noted)

Typical at $V_{DD} = +12\text{ V}$, $V_{SS} = 0\text{ V}$, $T_A = 25^\circ\text{C}$ (unless otherwise noted)

PARAMETER		TEST CONDITIONS	T_A	MIN	TYP	MAX	UNIT
t_{TRAN}	Transition time from control input	$V_S = 8\text{ V}$ $R_L = 300\ \Omega$, $C_L = 35\text{ pF}$ Refer to Transition Time	25°C		180	185	ns
			-40°C to +85°C			215	ns
			-40°C to +125°C			235	ns
$t_{\text{ON (EN)}}$	Turn-on time from enable	$V_S = 8\text{ V}$ $R_L = 300\ \Omega$, $C_L = 35\text{ pF}$ Refer to Turn-on and Turn-off Time	25°C		120	180	ns
			-40°C to +85°C			210	ns
			-40°C to +125°C			230	ns
$t_{\text{OFF (EN)}}$	Turn-off time from enable	$V_S = 8\text{ V}$ $R_L = 300\ \Omega$, $C_L = 35\text{ pF}$ Refer to Turn-on and Turn-off Time	25°C		130	210	ns
			-40°C to +85°C			235	ns
			-40°C to +125°C			250	ns
t_{BBM}	Break-before-make time delay	$V_S = 8\text{ V}$, $R_L = 300\ \Omega$, $C_L = 35\text{ pF}$ Refer to Break-Before-Make	25°C		40		ns
			-40°C to +85°C		1		ns
			-40°C to +125°C		1		ns
$T_{\text{ON (VDD)}}$	Device turn on time (V_{DD} to output)	V_{DD} rise time = 100ns $R_L = 300\ \Omega$, $C_L = 35\text{ pF}$ Refer to Turn-on (VDD) Time	25°C		0.19		ms
			-40°C to +85°C			0.2	ms
			-40°C to +125°C			0.2	ms
t_{PD}	Propagation delay	$R_L = 50\ \Omega$, $C_L = 5\text{ pF}$ Refer to Propagation Delay	25°C		740		ps
Q_{INJ}	Charge injection	$V_D = 6\text{ V}$, $C_L = 1\text{ nF}$ Refer to Charge Injection	25°C		-6		pC
O_{ISO}	Off-isolation	$R_L = 50\ \Omega$, $C_L = 5\text{ pF}$ $V_S = 6\text{ V}$, $f = 100\text{ kHz}$ Refer to Charge Injection	25°C		-75		dB
O_{ISO}	Off-isolation	$R_L = 50\ \Omega$, $C_L = 5\text{ pF}$ $V_S = 6\text{ V}$, $f = 1\text{ MHz}$ Refer to Off Isolation	25°C		-55		dB
X_{TALK}	Crosstalk	$R_L = 50\ \Omega$, $C_L = 5\text{ pF}$ $V_S = 6\text{ V}$, $f = 100\text{ kHz}$ Refer to Crosstalk	25°C		-117		dB
X_{TALK}	Crosstalk	$R_L = 50\ \Omega$, $C_L = 5\text{ pF}$ $V_S = 6\text{ V}$, $f = 1\text{ MHz}$ Refer to Crosstalk	25°C		-106		dB
BW	-3dB Bandwidth	$R_L = 50\ \Omega$, $C_L = 5\text{ pF}$ $V_S = 6\text{ V}$ Refer to Bandwidth	25°C		42		MHz
I_L	Insertion loss	$R_L = 50\ \Omega$, $C_L = 5\text{ pF}$ $V_S = 6\text{ V}$, $f = 1\text{ MHz}$	25°C		-0.3		dB
ACPSRR	AC Power Supply Rejection Ratio	$V_{PP} = 0.62\text{ V}$ on V_{DD} and V_{SS} $R_L = 50\ \Omega$, $C_L = 5\text{ pF}$, $f = 1\text{ MHz}$ Refer to ACPSRR	25°C		-65		dB
THD+N	Total Harmonic Distortion + Noise	$V_{PP} = 6\text{ V}$, $V_{BIAS} = 6\text{ V}$ $R_L = 10\text{ k}\Omega$, $C_L = 5\text{ pF}$, $f = 20\text{ Hz}$ to 20 kHz Refer to THD + Noise	25°C		0.0009		%
$C_{S(\text{OFF})}$	Source off capacitance	$V_S = 6\text{ V}$, $f = 1\text{ MHz}$	25°C		38		pF
$C_{D(\text{OFF})}$	Drain off capacitance	$V_S = 6\text{ V}$, $f = 1\text{ MHz}$	25°C		56		pF

$V_{DD} = +12\text{ V} \pm 10\%$, $V_{SS} = 0\text{ V}$, $GND = 0\text{ V}$ (unless otherwise noted)

 Typical at $V_{DD} = +12\text{ V}$, $V_{SS} = 0\text{ V}$, $T_A = 25^\circ\text{C}$ (unless otherwise noted)

PARAMETER		TEST CONDITIONS	T_A	MIN	TYP	MAX	UNIT
$C_{S(ON)}$, $C_{D(ON)}$	On capacitance	$V_S = 6\text{ V}$, $f = 1\text{ MHz}$	25°C		150		pF

5.14 Typical Characteristics

at $T_A = 25^\circ\text{C}$



图 5-1. On-Resistance vs Source or Drain Voltage - Dual Supply



图 5-2. On-Resistance vs Source or Drain Voltage - Dual Supply

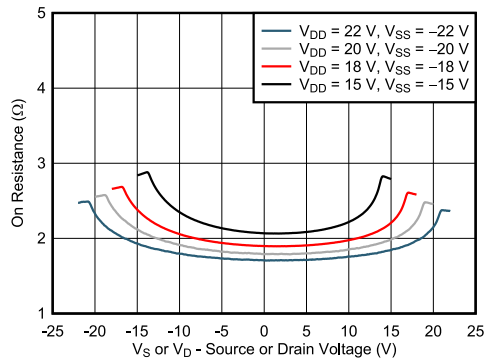

图 5-3. On-Resistance vs Source or Drain Voltage - Single Supply

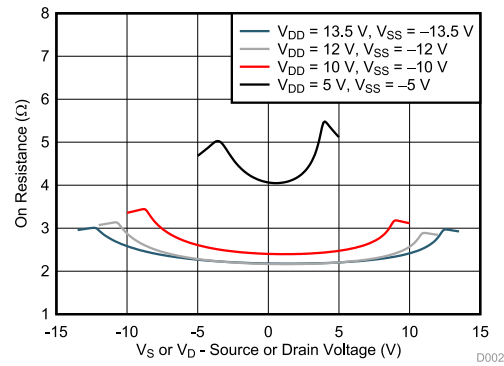

图 5-4. On-Resistance vs Source or Drain Voltage - Single Supply

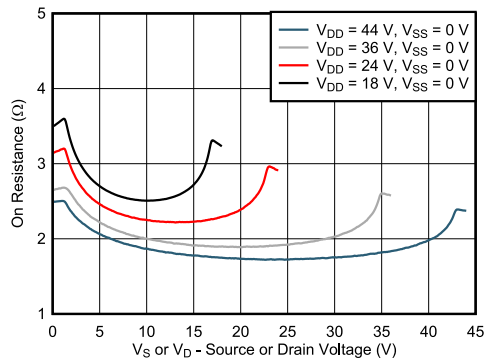

图 5-5. On-Resistance vs Temperature

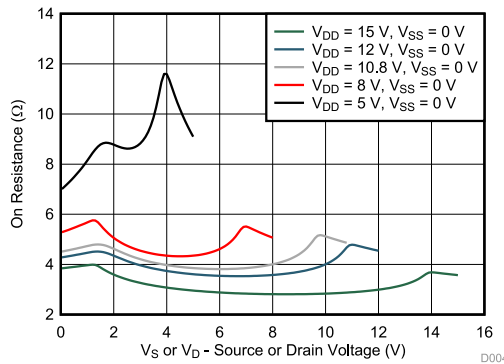

图 5-6. On-Resistance vs Temperature

5.14 Typical Characteristics (continued)

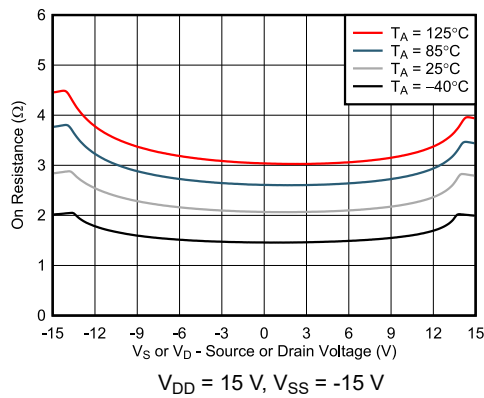
at $T_A = 25^\circ\text{C}$

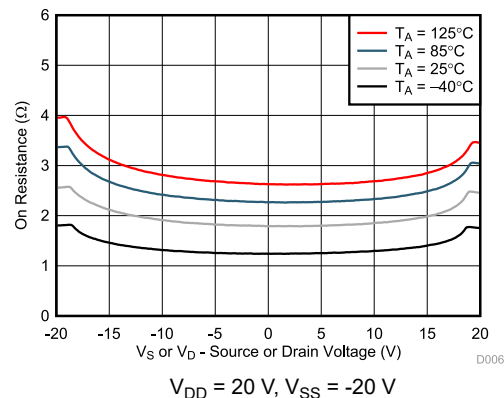

图 5-7. On-Resistance vs Temperature



图 5-8. On-Resistance vs Temperature

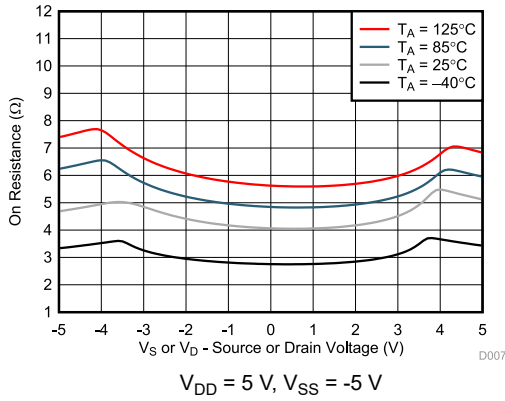

图 5-9. On-Resistance vs Temperature

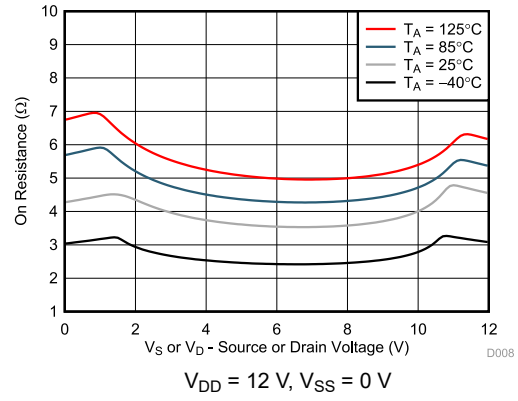

图 5-10. Leakage Current vs Temperature

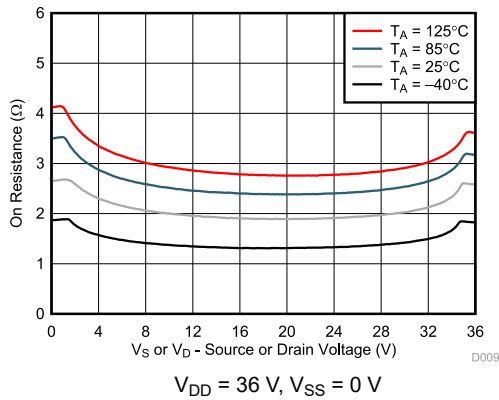

图 5-11. Leakage Current vs Temperature

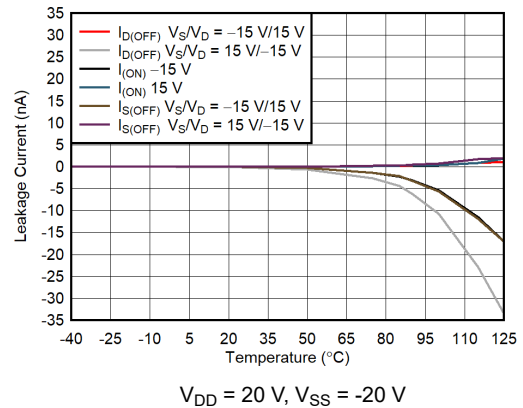

图 5-12. Leakage Current vs Temperature

5.14 Typical Characteristics (continued)

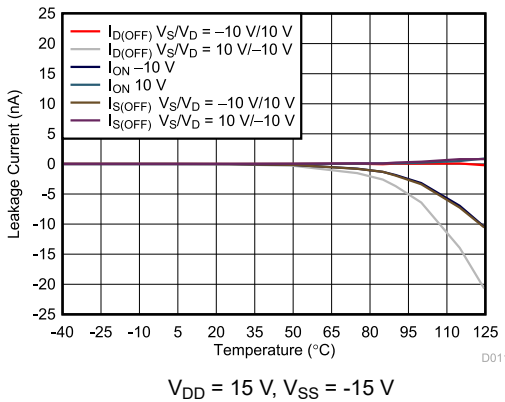
at $T_A = 25^\circ\text{C}$

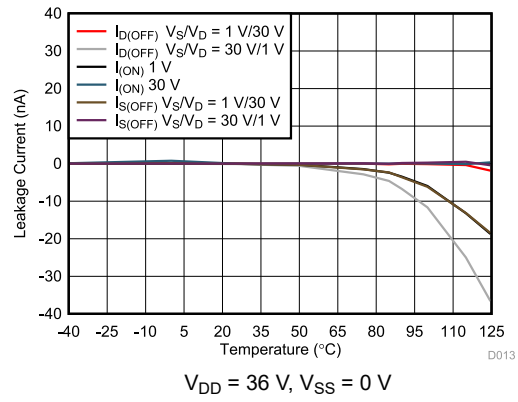
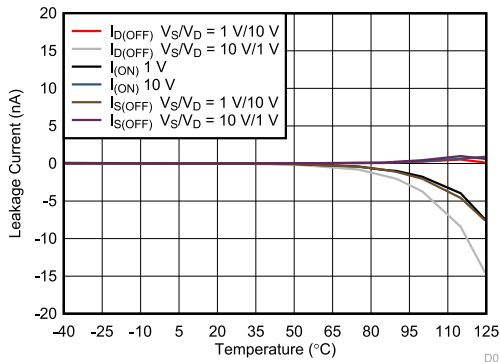

$V_{DD} = 12\text{ V}, V_{SS} = 0\text{ V}$

图 5-13. Leakage Current vs Temperature



图 5-14. Supply Current vs Logic Voltage



图 5-15. Charge Injection vs Source Voltage - Dual Supply

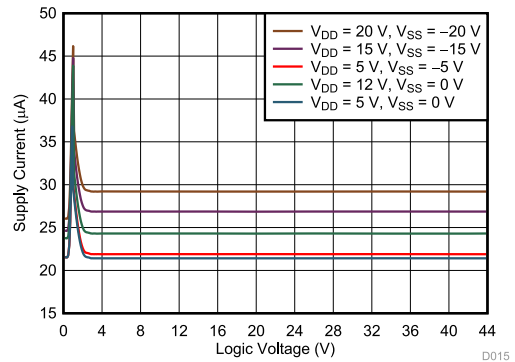

图 5-16. Charge Injection vs Drain Voltage - Dual Supply

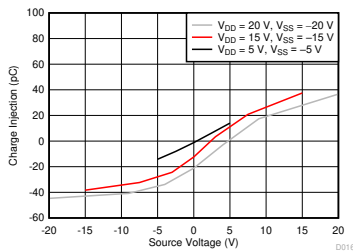

图 5-17. Charge Injection vs Source Voltage - Single Supply

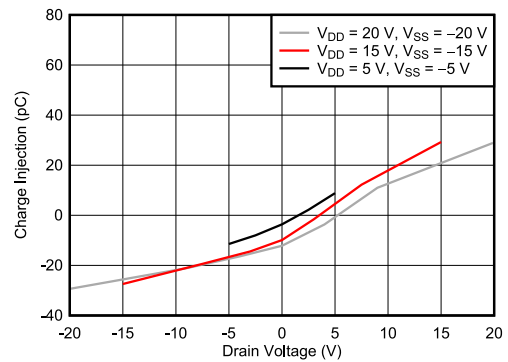

图 5-18. Charge Injection vs Drain Voltage - Single Supply

5.14 Typical Characteristics (continued)

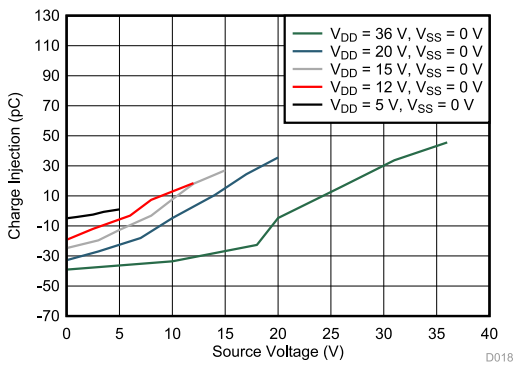
at $T_A = 25^\circ\text{C}$

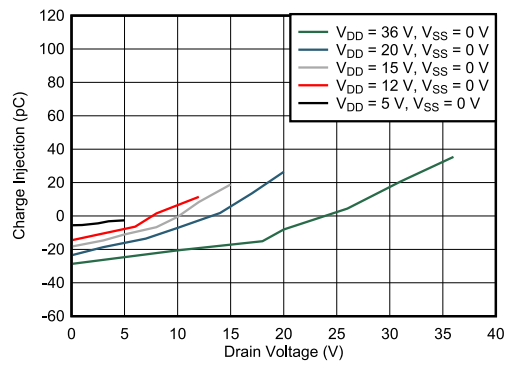
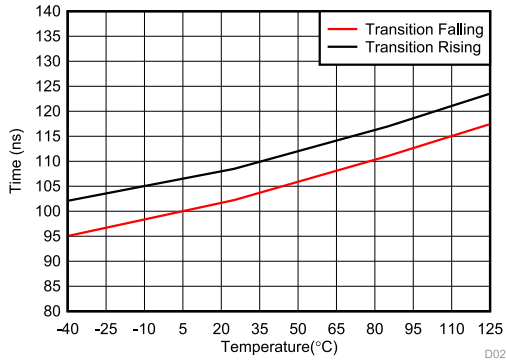

$V_{DD} = 15\text{ V}, V_{SS} = -15\text{ V}$

图 5-19. $T_{\text{TRANSITION}}$ vs Temperature

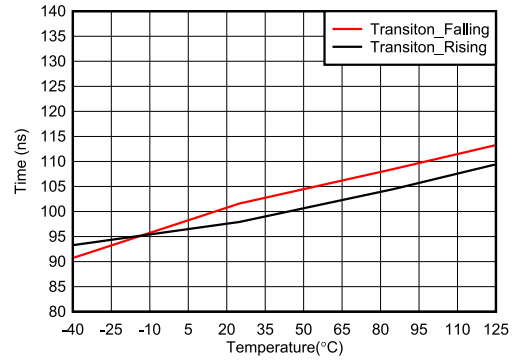

$V_{DD} = 44\text{ V}, V_{SS} = 0\text{ V}$

图 5-20. $T_{\text{TRANSITION}}$ vs Temperature

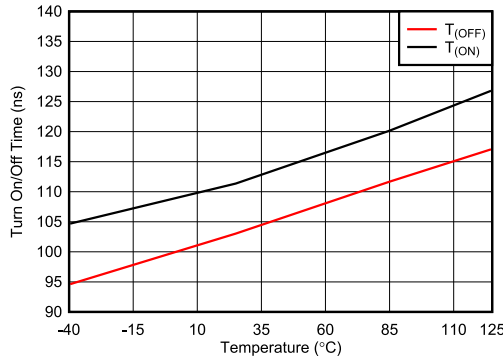

$V_{DD} = 15\text{ V}, V_{SS} = -15\text{ V}$

图 5-21. T_{ON} and T_{OFF} vs Temperature

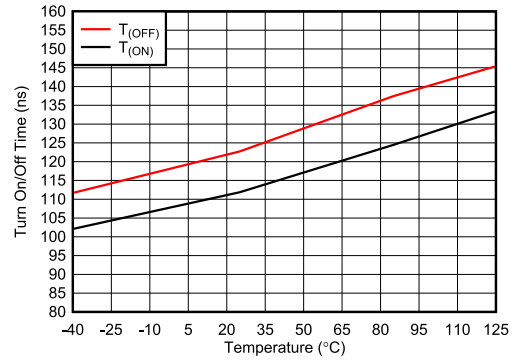

$V_{DD} = 44\text{ V}, V_{SS} = 0\text{ V}$

图 5-22. T_{ON} and T_{OFF} vs Temperature



图 5-23. Off-Isolation vs Frequency



Switch ON (EN = 1)

图 5-24. Crosstalk vs Frequency

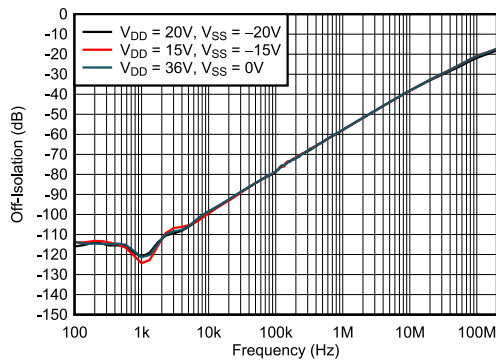
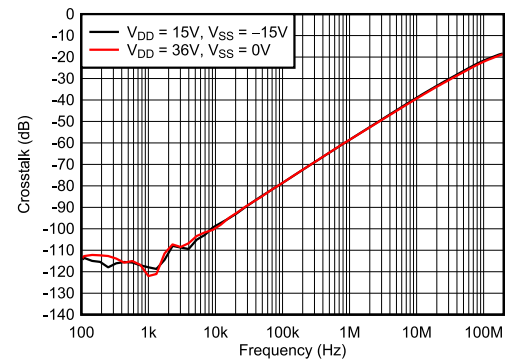
5.14 Typical Characteristics (continued)

at $T_A = 25^\circ\text{C}$



图 5-25. Crosstalk vs Frequency



图 5-26. THD+N vs Frequency (Dual Supply)

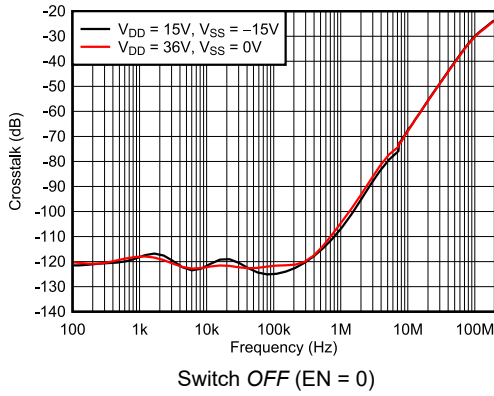

图 5-27. THD+N vs Frequency (Single Supply)

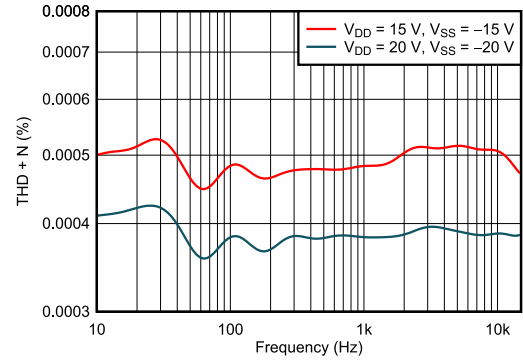

图 5-28. On Response vs Frequency

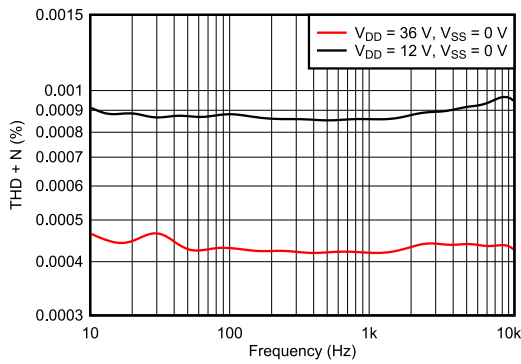

图 5-29. ACPSRR vs Frequency

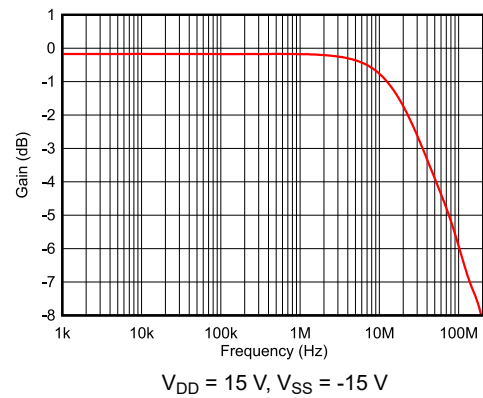

图 5-30. Capacitance vs Source Voltage or Drain Voltage

5.14 Typical Characteristics (continued)

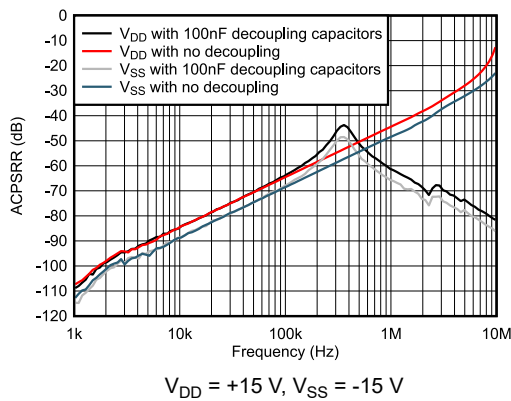
at $T_A = 25^\circ\text{C}$

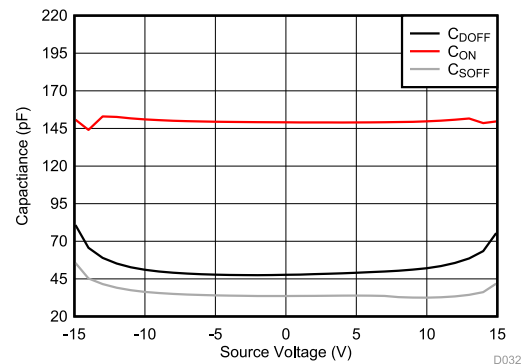

图 5-31. Capacitance vs Source Voltage or Drain Voltage

6 Parameter Measurement Information

6.1 On-Resistance

The on-resistance of a device is the ohmic resistance between the source (Sx) and drain (D) pins of the device. The on-resistance varies with input voltage and supply voltage. The symbol R_{ON} is used to denote on-resistance. 图 6-1 shows the measurement setup used to measure R_{ON} . Voltage (V) and current (I_{SD}) are measured using the following setup, where R_{ON} is computed as $R_{ON} = V / I_{SD}$:

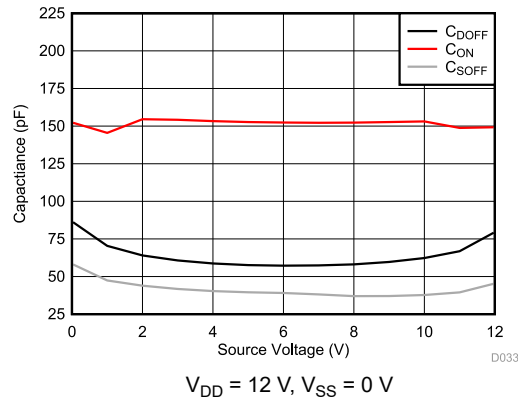

图 6-1. On-Resistance

6.2 Off-Leakage Current

There are two types of leakage currents associated with a switch during the off state:

1. Source off-leakage current.
2. Drain off-leakage current.

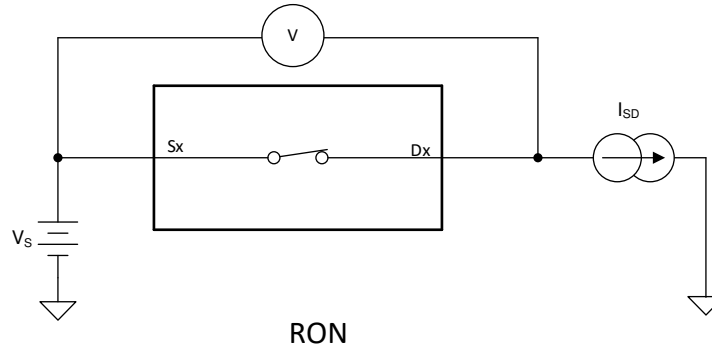
Source leakage current is defined as the leakage current flowing into or out of the source pin when the switch is off. This current is denoted by the symbol $I_{S(OFF)}$.

Drain leakage current is defined as the leakage current flowing into or out of the drain pin when the switch is off. This current is denoted by the symbol $I_{D(OFF)}$.

图 6-2 shows the setup used to measure both off-leakage currents.



图 6-2. Off-Leakage Measurement Setup

6.3 On-Leakage Current

Source on-leakage current is defined as the leakage current flowing into or out of the source pin when the switch is on. This current is denoted by the symbol $I_{S(ON)}$.

Drain on-leakage current is defined as the leakage current flowing into or out of the drain pin when the switch is on. This current is denoted by the symbol $I_{D(ON)}$.

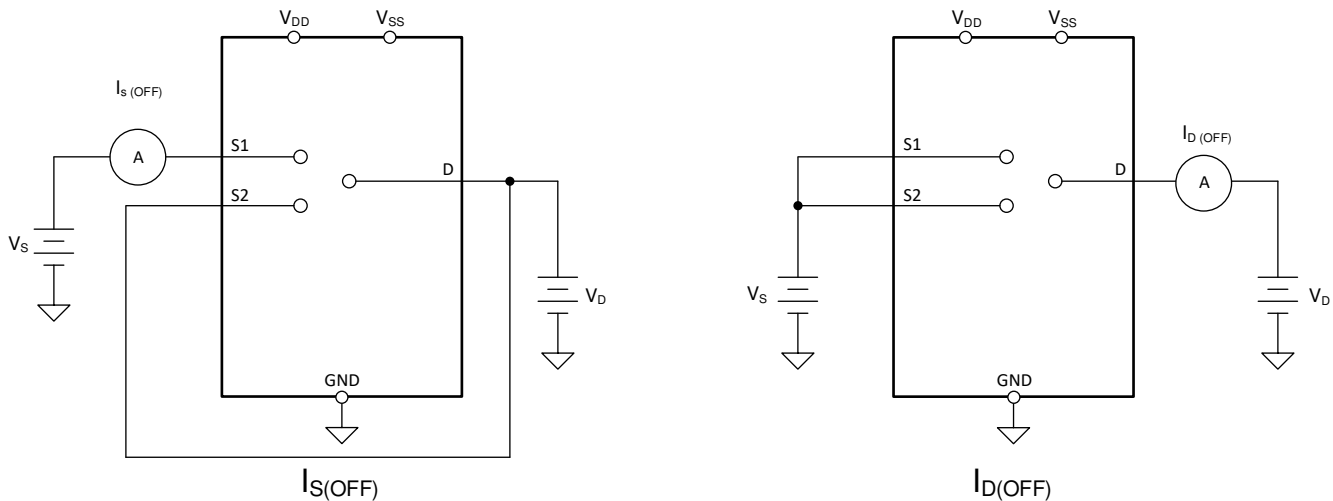
Either the source pin or drain pin is left floating during the measurement. 图 6-3 shows the circuit used for measuring the on-leakage current, denoted by $I_{S(ON)}$ or $I_{D(ON)}$.



图 6-3. On-Leakage Measurement Setup

6.4 Transition Time

Transition time is defined as the time taken by the output of the device to rise or fall 90% after the address signal has risen or fallen past the logic threshold. The 90% transition measurement is utilized to provide the timing of the device. System level timing can then account for the time constant added from the load resistance and load capacitance. 图 6-4 shows the setup used to measure transition time, denoted by the symbol $t_{TRANSITION}$.

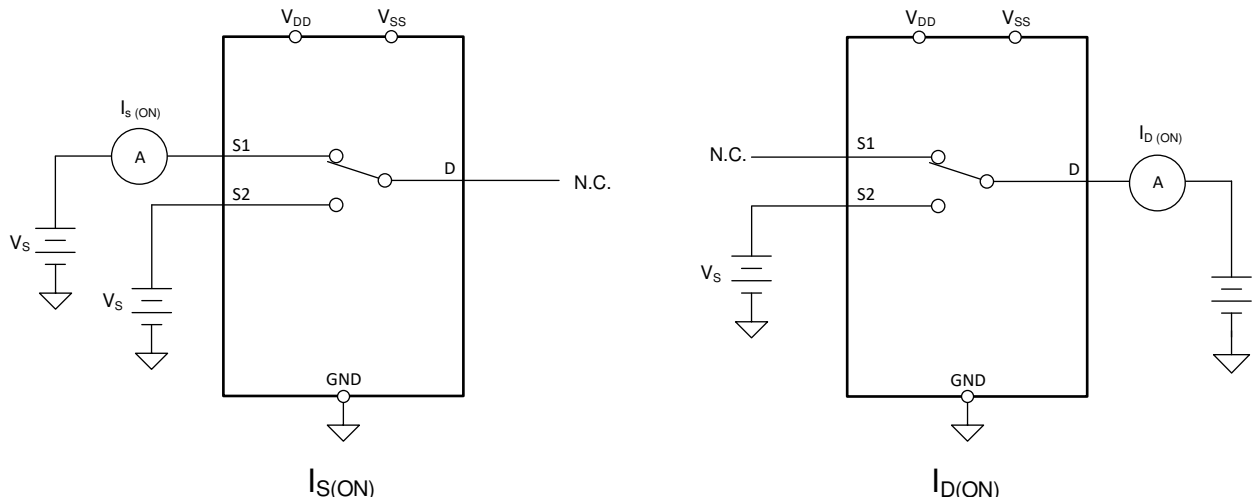

图 6-4. Transition-Time Measurement Setup

6.5 $t_{ON(EN)}$ and $t_{OFF(EN)}$

Turn-on time is defined as the time taken by the output of the device to rise to 90% after the enable has risen past the logic threshold. The 90% measurement is utilized to provide the timing of the device. System level timing can then account for the time constant added from the load resistance and load capacitance. 图 6-5 shows the setup used to measure turn-on time, denoted by the symbol $t_{ON(EN)}$.

Turn-off time is defined as the time taken by the output of the device to fall to 10% after the enable has fallen past the logic threshold. The 10% measurement is utilized to provide the timing of the device. System level timing can then account for the time constant added from the load resistance and load capacitance. 图 6-5 shows the setup used to measure turn-off time, denoted by the symbol $t_{OFF(EN)}$.

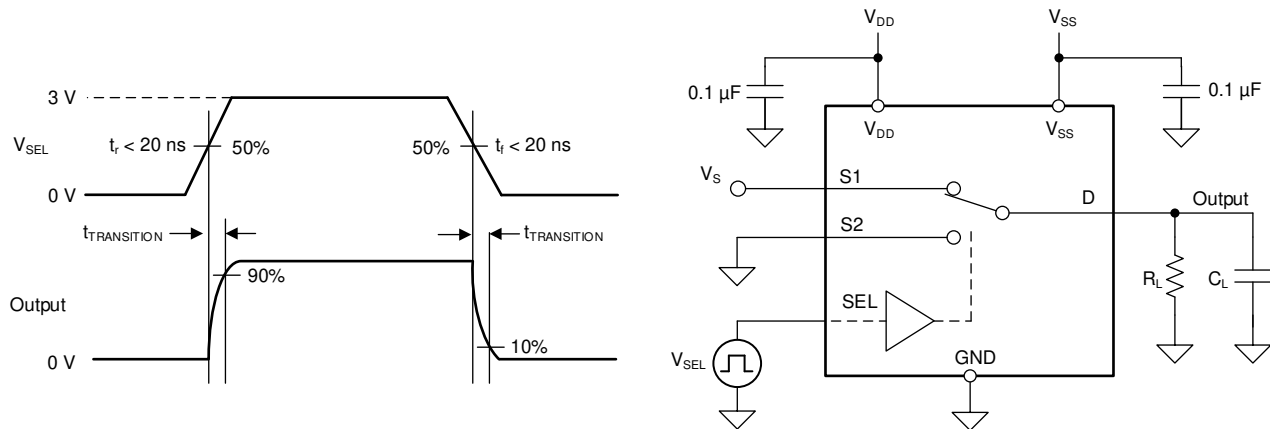

图 6-5. Turn-On and Turn-Off Time Measurement Setup

6.6 Break-Before-Make

Break-before-make delay is a safety feature that prevents two inputs from connecting when the device is switching. The output first breaks from the on-state switch before making the connection with the next on-state switch. The time delay between the *break* and the *make* is known as break-before-make delay. 图 6-6 shows the setup used to measure break-before-make delay, denoted by the symbol $t_{OPEN(BBM)}$.

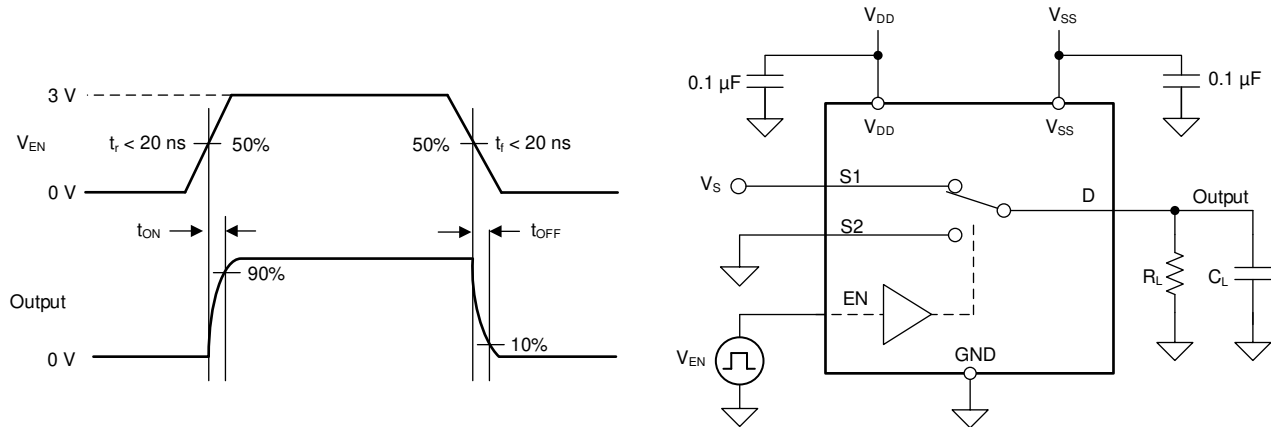

图 6-6. Break-Before-Make Delay Measurement Setup

6.7 $t_{ON(VDD)}$ Time

The $t_{ON(VDD)}$ time is defined as the time taken by the output of the device to rise to 90% after the supply has risen past the supply threshold. The 90% measurement is used to provide the timing of the device turning on in the system. 图 6-7 shows the setup used to measure turn on time, denoted by the symbol $t_{ON(VDD)}$.

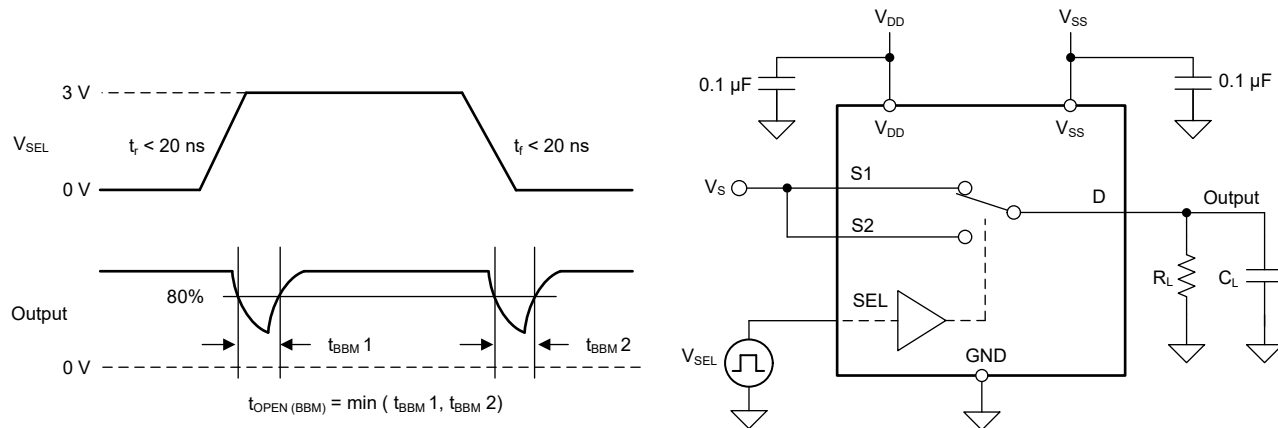

图 6-7. $t_{ON(VDD)}$ Time Measurement Setup

6.8 Propagation Delay

Propagation delay is defined as the time taken by the output of the device to rise or fall 50% after the input signal has risen or fallen past the 50% threshold. 图 6-8 shows the setup used to measure propagation delay, denoted by the symbol t_{PD} .

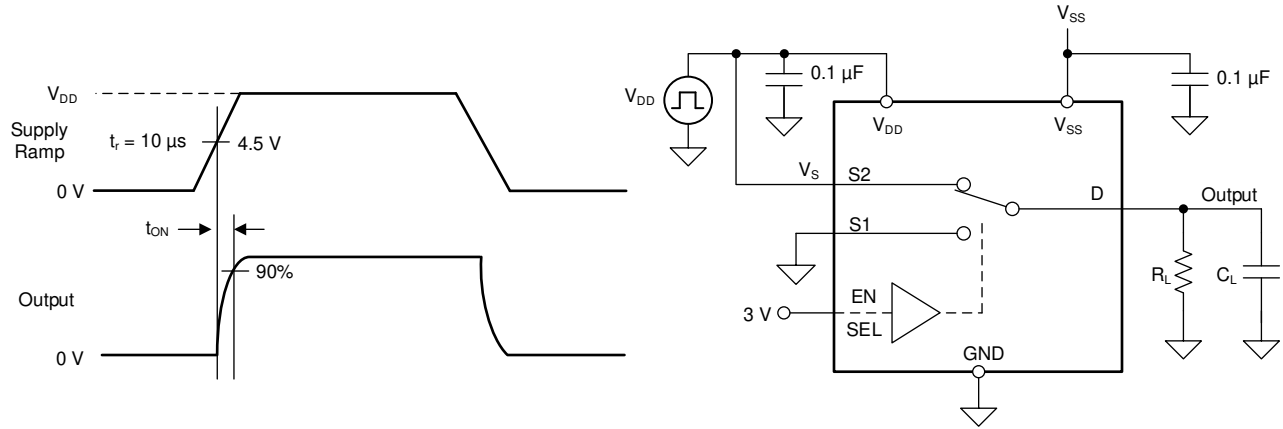

图 6-8. Propagation Delay Measurement Setup

6.9 Charge Injection

The TMUX7219-Q1 has a transmission-gate topology. Any mismatch in capacitance between the NMOS and PMOS transistors results in a charge injected into the drain or source during the falling or rising edge of the gate signal. The amount of charge injected into the source or drain of the device is known as charge injection, and is denoted by the symbol Q_C . 图 6-9 shows the setup used to measure charge injection from source (Sx) to drain (D).

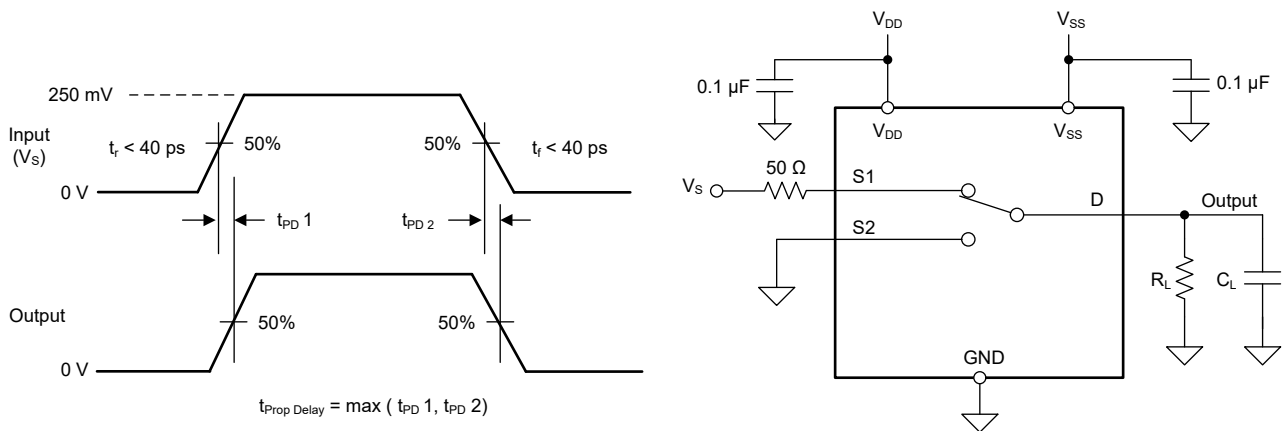

图 6-9. Charge-Injection Measurement Setup

6.10 Off Isolation

Off isolation is defined as the ratio of the signal at the drain pin (D) of the device when a signal is applied to the source pin (Sx) of an off-channel. 图 6-10 shows the setup used to measure, and the equation used to calculate off isolation.

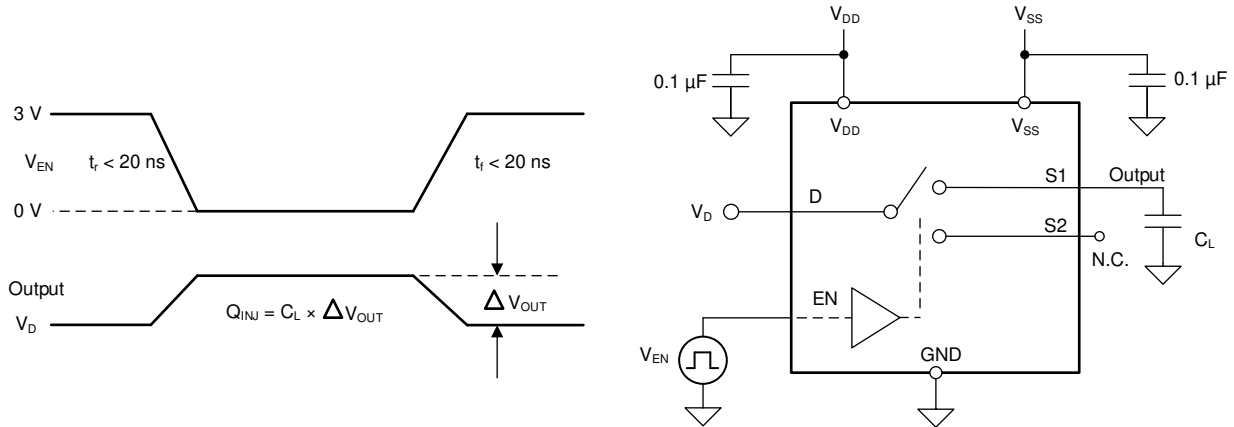
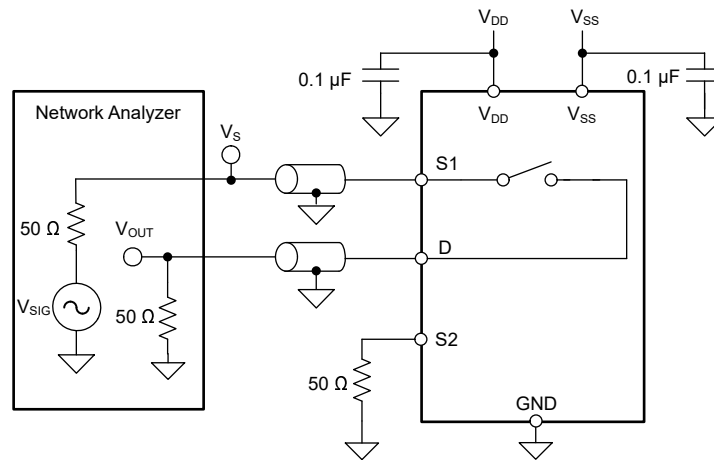

$$\text{Off Isolation} = 20 \times \text{Log} \frac{V_{\text{OUT}}}{V_S}$$

图 6-10. Off Isolation Measurement Setup

6.11 Crosstalk

Crosstalk is defined as the ratio of the signal at the drain pin (D) of a different channel, when a signal is applied at the source pin (Sx) of an on-channel. 图 6-11 shows the setup used to measure, and the equation used to calculate crosstalk.



图 6-11. Crosstalk Measurement Setup

6.12 Bandwidth

Bandwidth is defined as the range of frequencies that are attenuated by less than 3 dB when the input is applied to the source pin (Sx) of an on-channel, and the output is measured at the drain pin (D) of the device. 图 6-12 shows the setup used to measure bandwidth.

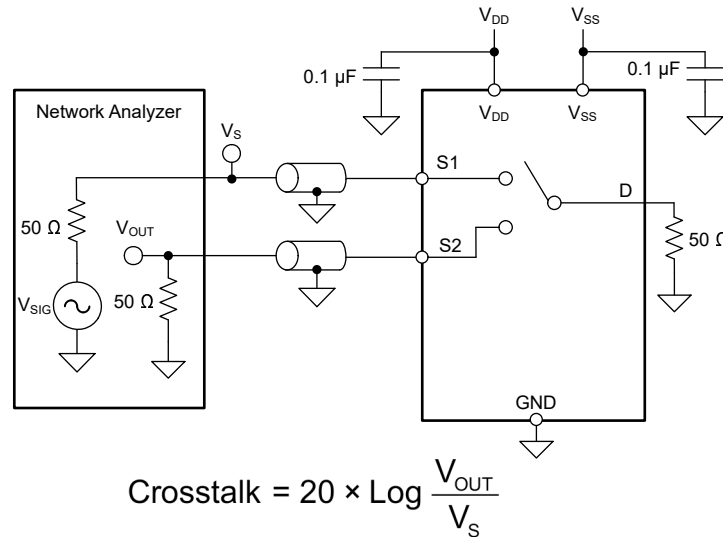

图 6-12. Bandwidth Measurement Setup

6.13 THD + Noise

The total harmonic distortion (THD) of a signal is a measurement of the harmonic distortion, and is defined as the ratio of the sum of the powers of all harmonic components to the power of the fundamental frequency at the mux output.

The on-resistance of the device varies with the amplitude of the input signal and results in distortion when the drain pin is connected to a low-impedance load. Total harmonic distortion plus noise is denoted as THD + N.

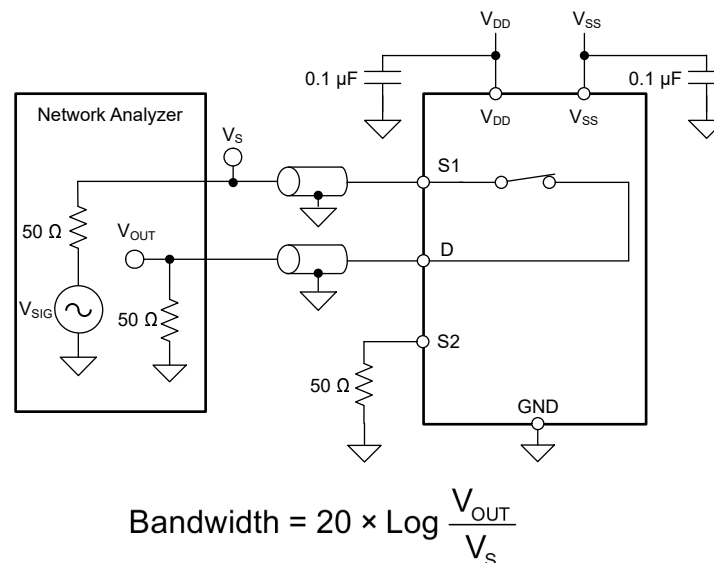

图 6-13. THD + N Measurement Setup

6.14 Power Supply Rejection Ratio (PSRR)

PSRR measures the ability of a device to prevent noise and spurious signals that appear on the supply voltage pin from coupling to the output of the switch. The DC voltage on the device supply is modulated by a sine wave of 620 mV_{PP}. The ratio of the amplitude of signal on the output to the amplitude of the modulated signal is the ACPSRR. A high ratio represents a high degree of tolerance to supply rail variation.

This helps stabilize the supply and immediately filter as much of the supply noise as possible.

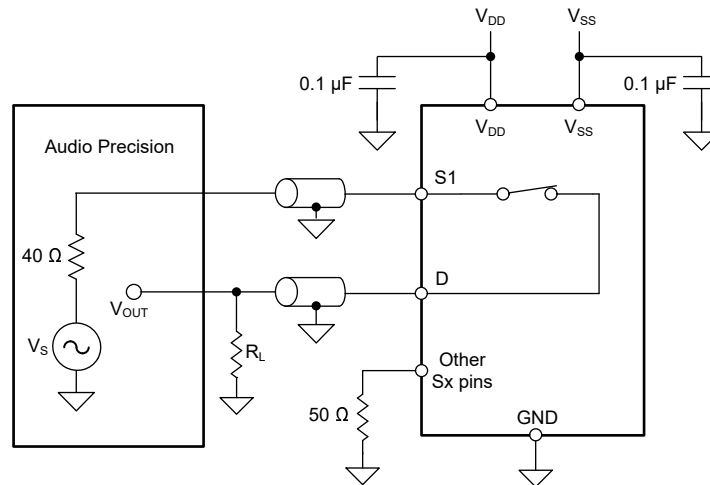
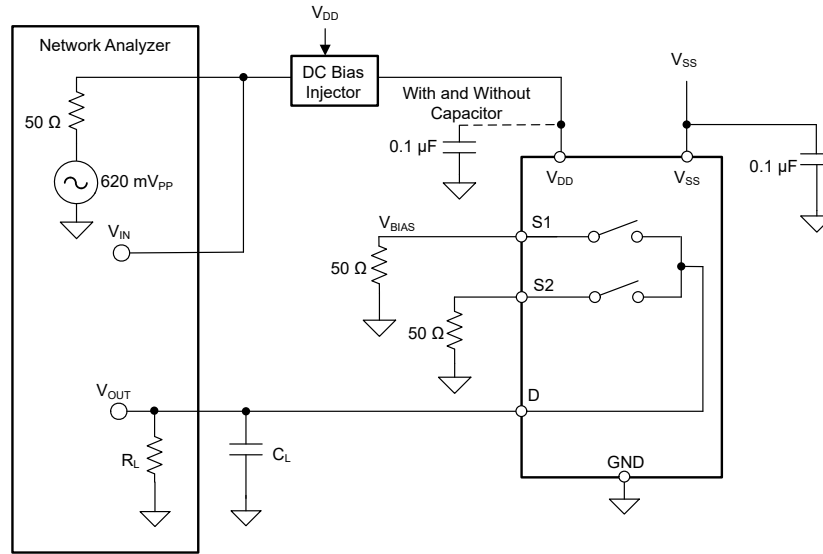

$$PSRR = 20 \times \text{Log} \frac{V_{OUT}}{V_{IN}}$$

图 6-14. ACPSRR Measurement Setup

7 Detailed Description

7.1 Overview

The TMUX7219-Q1 is a 2:1, 1-channel switch. Each input is turned on or turned off based on the state of the select line and enable pin.

7.2 Functional Block Diagram

The following figure shows the functional block diagram of the TMUX7219-Q1.

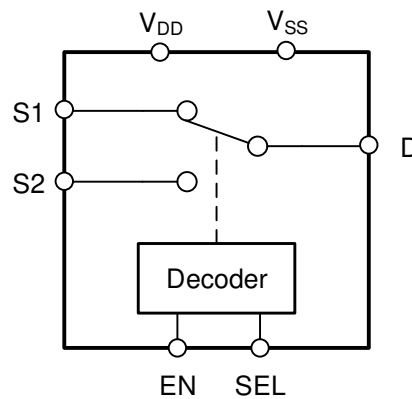

7.3 Feature Description

7.3.1 Bidirectional Operation

The TMUX7219-Q1 conducts equally well from source (Sx) to drain (D) or from drain (D) to source (Sx). Each channel has very similar characteristics in both directions and supports both analog and digital signals.

7.3.2 Rail-to-Rail Operation

The valid signal path input and output voltage for TMUX7219-Q1 ranges from V_{SS} to V_{DD} .

7.3.3 1.8 V Logic Compatible Inputs

The TMUX7219-Q1 has 1.8 V logic compatible control for all logic control inputs. 1.8 V logic level inputs allows the device to interface with processors that have lower logic I/O rails and eliminates the need for an external translator, which saves both space and BOM cost. For more information on 1.8 V logic implementations refer to [Simplifying Design with 1.8 V logic Muxes and Switches](#).

7.3.4 Integrated Pull-Up and Pull-Down Resistor on Logic Pins

The TMUX7219-Q1 has internal weak pull-up and pull-down resistors to GND to ensure the logic pins are not left floating. The value of this pull-down resistor is approximately 4 M Ω , but is clamped to about 1 μ A at higher voltages. The EN pin integrates a pull-up resistor to V_{DD} and the SEL pin integrates a pull-down resistor. This feature integrates up to two external components and reduces system size and cost.

7.3.5 Fail-Safe Logic

The TMUX7219-Q1 supports Fail-Safe Logic on the control input pins (EN and SEL) allowing for operation up to 44 V above ground, regardless of the state of the supply pins. This feature allows voltages on the control pins to be applied before the supply pin, protecting the device from potential damage. Fail-Safe Logic minimizes system complexity by removing the need for power supply sequencing on the logic control pins. For example, the Fail-Safe Logic feature allows the logic input pins of the TMUX7219-Q1 to be ramped to +44 V while V_{DD} and V_{SS} = 0 V. The logic control inputs are protected against positive faults of up to +44 V in powered-off condition, but do not offer protection against negative overvoltage conditions.

7.3.6 Latch-Up Immune

Latch-up is a condition where a low impedance path is created between a supply pin and ground. This condition is caused by a trigger (current injection or overvoltage), but once activated, the low impedance path remains even after the trigger is no longer present. This low impedance path may cause system upset or catastrophic damage due to excessive current levels. The latch-up condition typically requires a power cycle to eliminate the low impedance path.

The TMUX72xx-Q1 family of devices are constructed on Silicon on Insulator (SOI) based process where an oxide layer is added between the PMOS and NMOS transistor of each CMOS switch to prevent parasitic structures from forming. The oxide layer is also known as an insulating trench and prevents triggering of latch up events due to overvoltage or current injections. The latch-up immunity feature allows the TMUX72xx-Q1 family of switches and multiplexers to be used in harsh environments. For more information on latch-up immunity refer to [Using Latch Up Immune Multiplexers to Help Improve System Reliability](#).

7.3.7 Ultra-Low Charge Injection

图 7-1 shows how the TMUX7219-Q1 has a transmission gate topology. Any mismatch in the stray capacitance associated with the NMOS and PMOS causes an output level change whenever the switch is opened or closed.



图 7-1. Transmission Gate Topology

The TMUX7219-Q1 contains specialized architecture to reduce charge injection on the source (Sx). To further reduce charge injection in a sensitive application, a compensation capacitor (Cp) can be added on the drain (D). This will ensure that excess charge from the switch transition will be pushed into the compensation capacitor on the drain (D) instead of the source (Sx). As a general rule, Cp should be 20× larger than the equivalent load capacitance on the source (Sx).  shows charge injection variation with source voltage with different compensation capacitors on the drain side.

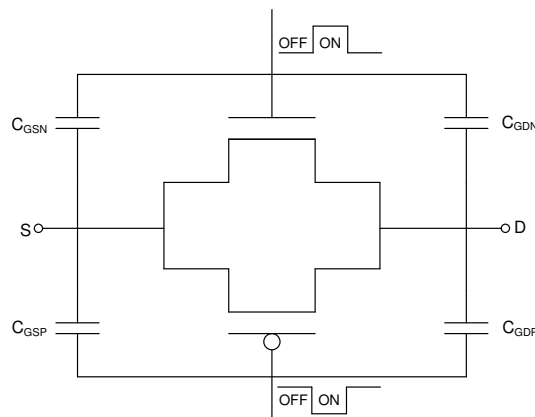
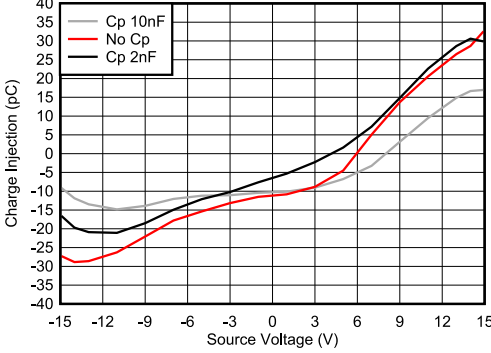

图 7-2. Charge Injection Compensation

7.4 Device Functional Modes

When the EN pin of the TMUX7219-Q1 is pulled high, one of the switches is closed based on the state of the SEL pin. When the EN pin is pulled low, both of the switches are in an open state regardless of the state of the SEL pin. The control pins can be as high as 44 V.

The TMUX7219-Q1 can operate without any external components except for the supply decoupling capacitors. The EN pin has an internal pull-up resistor of $4\text{ M}\Omega$, and SEL pin has internal pull-down resistor of $4\text{ M}\Omega$. If unused, EN pin must be tied to V_{DD} and SEL pin must be tied to GND to ensure the device does not consume additional current as highlighted in [Implications of Slow or Floating CMOS Inputs](#). Unused signal path inputs (S1, S2, or D) should be connected to GND.

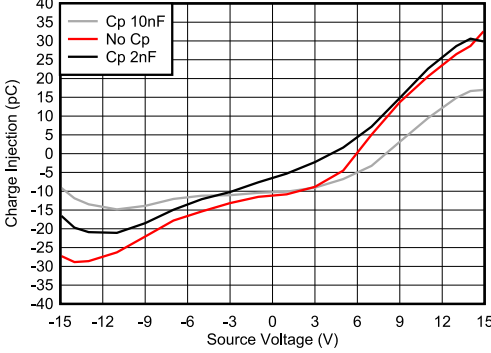
7.5 Truth Tables

表 7-1 show the truth tables for the TMUX7219-Q1.

表 7-1. TMUX7219-Q1 Truth Table

EN	SEL	Selected Source Connected To Drain (D) Pin
0	X ⁽¹⁾	All sources are off (HI-Z)
1	0	S1
1	1	S2

(1) X denotes *do not care*.

8 Application and Implementation

备注

以下应用部分中的信息不属于 TI 器件规格的范围，TI 不担保其准确性和完整性。TI 的客户应负责确定器件是否适用于其应用。客户应验证并测试其设计，以确保系统功能。

8.1 Application Information

TMUX7219-Q1 is part of the precision switches and multiplexers family of devices. TMUX7219-Q1 offers low RON, low on and off leakage currents, and ultra-low charge injection performance. These properties make TMUX7219-Q1 ideal for implementing high precision industrial systems requiring selection of one of two inputs or outputs.

8.2 Typical Applications

8.2.1 Data Acquisition Calibration

One application of the TMUX7219-Q1 is in Data Acquisition systems (DAQ). To account for system loss and ensure the lowest possible noise floor, a calibration path is needed. To minimize board space and automate this procedure, many applications utilize a 2:1 (SPDT) switch. 图 8-1 shows the TMUX7219-Q1 configured for switching a calibration path on a precision measurement module.



图 8-1. Calibration Path Switching for Data Acquisition

8.2.2 Design Requirements

For the design example, use the parameters listed in 表 8-1.

表 8-1. Design Parameters

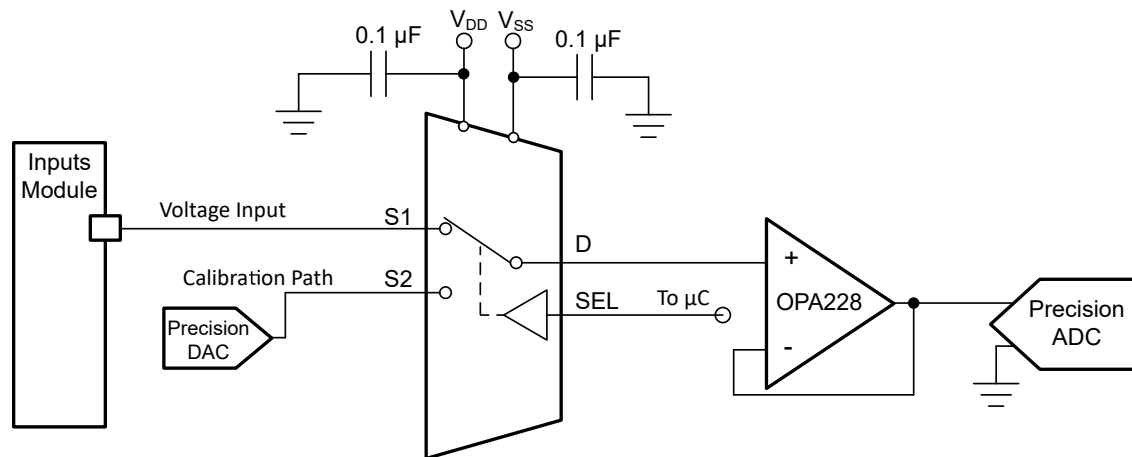
PARAMETERS	VALUES
Supply (V_{DD})	12 V
Supply (V_{SS})	-12 V
MUX I/O signal range	-12 V to 12 V (Rail-to-Rail)
Control logic thresholds	1.8 V compatible (up to V_{DD})
EN	EN pulled high to enable the switch

8.2.3 Detailed Design Procedure

The application shown in 图 8-1 demonstrates how to generate a $\pm 12\text{V}$ PWM signal that is created by toggling the TMUX7219-Q1. This PWM signal generated by the EVSE on the control pilot line signals to the car the available current of the charger, and the car will respond with a charging status. This handshake results in a safe method for supplying power to vehicle. The TMUX7219-Q1 can support 1.8V logic signals on the control input, allowing the device to interface with low logic controls of an FPGA or MCU. The TMUX7219-Q1 can be operated without any external components except for the supply decoupling capacitors. The select pin has an internal pull-down resistor to prevent floating input logic. All inputs to the switch must fall within the recommend operating conditions of the TMUX7219-Q1 including signal range and continuous current. For this design with a positive supply of 12V on V_{DD} , and negative supply of -12V on V_{SS} , the signal range can be 12V to -12V . The max continuous current (I_{DC}) can be up to 330mA as shown in 节 5.4 for wide-range current measurement.

8.3 Power Supply Recommendations

The TMUX7219-Q1 operates across a wide supply range of $\pm 4.5\text{ V}$ to $\pm 22\text{ V}$ (4.5 V to 44 V in single-supply mode). The device also performs well with asymmetrical supplies such as $V_{DD} = 12\text{ V}$ and $V_{SS} = -5\text{ V}$.

Power-supply bypassing improves noise margin and prevents switching noise propagation from the supply rails to other components. Good power-supply decoupling is important to achieve optimum performance. For improved supply noise immunity, use a supply decoupling capacitor ranging from $0.1\ \mu\text{F}$ to $10\ \mu\text{F}$ at both the V_{DD} and V_{SS} pins to ground. Place the bypass capacitors as close to the power supply pins of the device as possible using low-impedance connections. TI recommends using multi-layer ceramic chip capacitors (MLCCs) that offer low equivalent series resistance (ESR) and inductance (ESL) characteristics for power-supply decoupling purposes. For very sensitive systems, or for systems in harsh noise environments, avoiding the use of vias for connecting the capacitors to the device pins may offer superior noise immunity. The use of multiple vias in parallel lowers the overall inductance and is beneficial for connections to ground and power planes. Always ensure the ground (GND) connection is established before supplies are ramped.

8.4 Layout

8.4.1 Layout Guidelines

When a PCB trace turns a corner at a 90° angle, a reflection can occur. A reflection occurs primarily because of the change of width of the trace. At the apex of the turn, the trace width increases to 1.414 times the width. This increase upsets the transmission-line characteristics, especially the distributed capacitance and self-inductance of the trace which results in the reflection. Not all PCB traces can be straight and therefore some traces must turn corners. 图 8-2 shows progressively better techniques of rounding corners. Only the last example (BEST) maintains constant trace width and minimizes reflections.



图 8-2. Trace Example

Route high-speed signals using a minimum of vias and corners which reduces signal reflections and impedance changes. When a via must be used, increase the clearance size around it to minimize its capacitance. Each via introduces discontinuities in the signal's transmission line and increases the chance of picking up interference

from the other layers of the board. Be careful when designing test points, through-hole pins are not recommended at high frequencies.

图 8-3 shows an example of a PCB layout with the TMUX7219-Q1. Some key considerations are as follows:

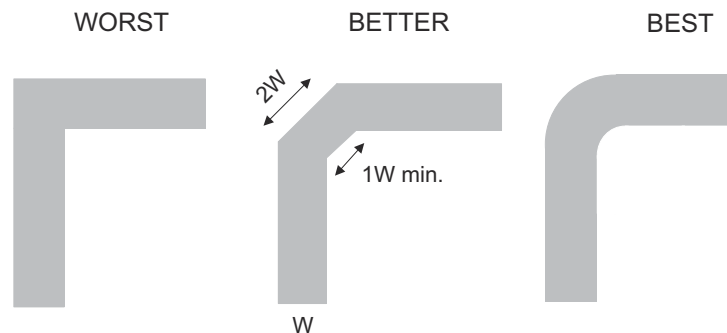
- For reliable operation, connect a decoupling capacitor ranging from 0.1 μF to 10 μF between VDD/VSS and GND. We recommend a 0.1 μF and 1 μF capacitor, placing the lowest value capacitor as close to the pin as possible. Make sure that the capacitor voltage rating is sufficient for the supply voltage.
- Keep the input lines as short as possible.
- Use a solid ground plane to help reduce electromagnetic interference (EMI) noise pickup.
- Do not run sensitive analog traces in parallel with digital traces. Avoid crossing digital and analog traces if possible, and only make perpendicular crossings when necessary.
- Using multiple vias in parallel will lower the overall inductance and is beneficial for connection to ground planes.

8.4.2 Layout Example



图 8-3. TMUX7219-Q1DGK Layout Example

9 Device and Documentation Support

9.1 Documentation Support

9.1.1 Related Documentation

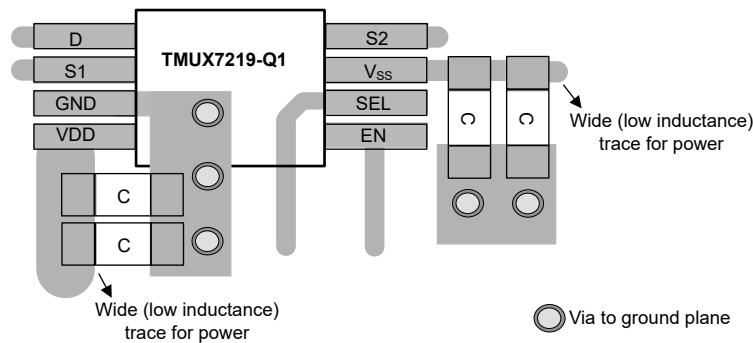
For related documentation, see the following:

- Texas Instruments, [Improve Stability Issues with Low CON Multiplexers](#) application brief
- Texas Instruments, [Improving Signal Measurement Accuracy in Automated Test Equipment](#) application brief
- Texas Instruments, [Multiplexers and Signal Switches Glossary](#) application report
- Texas Instruments, [QFN/SON PCB Attachment](#) application report
- Texas Instruments, [Quad Flatpack No-Lead Logic Packages](#) application report
- Texas Instruments, [Simplifying Design with 1.8 V logic Muxes and Switches](#) application brief
- Texas Instruments, [System-Level Protection for High-Voltage Analog Multiplexers](#) application report
- Texas Instruments, [TMUX7219-Q1 Functional Safety, FIT Rate, Failure Mode Distribution and Pin FMA](#) functional safety FIT rate, FMD and Pin-FMA

9.2 Receiving Notification of Documentation Updates

To receive notification of documentation updates, navigate to the device product folder on ti.com. In the upper right corner, click on *Alert me* to register and receive a weekly digest of any product information that has changed. For change details, review the revision history included in any revised document.

9.3 支持资源

TI E2E™ 中文支持论坛是工程师的重要参考资料，可直接从专家处获得快速、经过验证的解答和设计帮助。搜索现有解答或提出自己的问题，获得所需的快速设计帮助。

链接的内容由各个贡献者“按原样”提供。这些内容并不构成 TI 技术规范，并且不一定反映 TI 的观点；请参阅 TI 的[使用条款](#)。

9.4 Trademarks

TI E2E™ is a trademark of Texas Instruments.

所有商标均为其各自所有者的财产。

9.5 静电放电警告



静电放电 (ESD) 会损坏这个集成电路。德州仪器 (TI) 建议通过适当的预防措施处理所有集成电路。如果不遵守正确的处理和安装程序，可能会损坏集成电路。

ESD 的损坏小至导致微小的性能降级，大至整个器件故障。精密的集成电路可能更容易受到损坏，这是因为非常细微的参数更改都可能会导致器件与其发布的规格不相符。

9.6 术语表

TI 术语表 本术语表列出并解释了术语、首字母缩略词和定义。

10 Revision History

注：以前版本的页码可能与当前版本的页码不同

Changes from Revision A (June 2021) to Revision B (July 2024)	Page
• Updated IIH max specification.....	6

Changes from Revision * (January 2021) to Revision A (June 2021)	Page
• 将数据表的状态从 <i>预告信息</i> 更改为 <i>量产数据</i>	1

11 Mechanical, Packaging, and Orderable Information

The following pages include mechanical, packaging, and orderable information. This information is the most current data available for the designated devices. This data is subject to change without notice and revision of this document. For browser-based versions of this data sheet, refer to the left-hand navigation.

PACKAGING INFORMATION

Orderable Device	Status (1)	Package Type	Package Drawing	Pins	Package Qty	Eco Plan (2)	Lead finish/ Ball material (6)	MSL Peak Temp (3)	Op Temp (°C)	Device Marking (4/5)	Samples
TMUX7219DGKRQ1	ACTIVE	VSSOP	DGK	8	2500	RoHS & Green	NIPDAU	Level-1-260C-UNLIM	-40 to 125	(X219, X219Q) Q	Samples

(1) The marketing status values are defined as follows:

ACTIVE: Product device recommended for new designs.

LIFEBUY: TI has announced that the device will be discontinued, and a lifetime-buy period is in effect.

NRND: Not recommended for new designs. Device is in production to support existing customers, but TI does not recommend using this part in a new design.

PREVIEW: Device has been announced but is not in production. Samples may or may not be available.

OBSOLETE: TI has discontinued the production of the device.

(2) **RoHS:** TI defines "RoHS" to mean semiconductor products that are compliant with the current EU RoHS requirements for all 10 RoHS substances, including the requirement that RoHS substance do not exceed 0.1% by weight in homogeneous materials. Where designed to be soldered at high temperatures, "RoHS" products are suitable for use in specified lead-free processes. TI may reference these types of products as "Pb-Free".

RoHS Exempt: TI defines "RoHS Exempt" to mean products that contain lead but are compliant with EU RoHS pursuant to a specific EU RoHS exemption.

Green: TI defines "Green" to mean the content of Chlorine (Cl) and Bromine (Br) based flame retardants meet JS709B low halogen requirements of <=1000ppm threshold. Antimony trioxide based flame retardants must also meet the <=1000ppm threshold requirement.

(3) MSL, Peak Temp. - The Moisture Sensitivity Level rating according to the JEDEC industry standard classifications, and peak solder temperature.

(4) There may be additional marking, which relates to the logo, the lot trace code information, or the environmental category on the device.

(5) Multiple Device Markings will be inside parentheses. Only one Device Marking contained in parentheses and separated by a "~" will appear on a device. If a line is indented then it is a continuation of the previous line and the two combined represent the entire Device Marking for that device.

(6) Lead finish/Ball material - Orderable Devices may have multiple material finish options. Finish options are separated by a vertical ruled line. Lead finish/Ball material values may wrap to two lines if the finish value exceeds the maximum column width.

Important Information and Disclaimer:The information provided on this page represents TI's knowledge and belief as of the date that it is provided. TI bases its knowledge and belief on information provided by third parties, and makes no representation or warranty as to the accuracy of such information. Efforts are underway to better integrate information from third parties. TI has taken and continues to take reasonable steps to provide representative and accurate information but may not have conducted destructive testing or chemical analysis on incoming materials and chemicals. TI and TI suppliers consider certain information to be proprietary, and thus CAS numbers and other limited information may not be available for release.

In no event shall TI's liability arising out of such information exceed the total purchase price of the TI part(s) at issue in this document sold by TI to Customer on an annual basis.

OTHER QUALIFIED VERSIONS OF TMUX7219-Q1 :

- Catalog : [TMUX7219](#)

NOTE: Qualified Version Definitions:

- Catalog - TI's standard catalog product

TAPE AND REEL INFORMATION

QUADRANT ASSIGNMENTS FOR PIN 1 ORIENTATION IN TAPE

*All dimensions are nominal

Device	Package Type	Package Drawing	Pins	SPQ	Reel Diameter (mm)	Reel Width W1 (mm)	A0 (mm)	B0 (mm)	K0 (mm)	P1 (mm)	W (mm)	Pin1 Quadrant
TMUX7219DGKRQ1	VSSOP	DGK	8	2500	330.0	12.4	5.25	3.35	1.25	8.0	12.0	Q1

TAPE AND REEL BOX DIMENSIONS

*All dimensions are nominal

Device	Package Type	Package Drawing	Pins	SPQ	Length (mm)	Width (mm)	Height (mm)
TMUX7219DGKRQ1	VSSOP	DGK	8	2500	366.0	364.0	50.0

DGK0008A

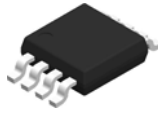

PACKAGE OUTLINE
VSSOP - 1.1 mm max height

SMALL OUTLINE PACKAGE



4214862/A 04/2023

NOTES:

PowerPAD is a trademark of Texas Instruments.

1. All linear dimensions are in millimeters. Any dimensions in parenthesis are for reference only. Dimensioning and tolerancing per ASME Y14.5M.
2. This drawing is subject to change without notice.
3. This dimension does not include mold flash, protrusions, or gate burrs. Mold flash, protrusions, or gate burrs shall not exceed 0.15 mm per side.
4. This dimension does not include interlead flash. Interlead flash shall not exceed 0.25 mm per side.
5. Reference JEDEC registration MO-187.

EXAMPLE BOARD LAYOUT

DGK0008A

™ VSSOP - 1.1 mm max height

SMALL OUTLINE PACKAGE



LAND PATTERN EXAMPLE
EXPOSED METAL SHOWN
SCALE: 15X



SOLDER MASK DETAILS

4214862/A 04/2023

NOTES: (continued)

6. Publication IPC-7351 may have alternate designs.
7. Solder mask tolerances between and around signal pads can vary based on board fabrication site.
8. Vias are optional depending on application, refer to device data sheet. If any vias are implemented, refer to their locations shown on this view. It is recommended that vias under paste be filled, plugged or tented.
9. Size of metal pad may vary due to creepage requirement.

EXAMPLE STENCIL DESIGN

DGK0008A

™ VSSOP - 1.1 mm max height

SMALL OUTLINE PACKAGE



SOLDER PASTE EXAMPLE
SCALE: 15X

4214862/A 04/2023

NOTES: (continued)

11. Laser cutting apertures with trapezoidal walls and rounded corners may offer better paste release. IPC-7525 may have alternate design recommendations.
12. Board assembly site may have different recommendations for stencil design.

重要声明和免责声明

TI“按原样”提供技术和可靠性数据（包括数据表）、设计资源（包括参考设计）、应用或其他设计建议、网络工具、安全信息和其他资源，不保证没有瑕疵且不做任何明示或暗示的担保，包括但不限于对适销性、某特定用途方面的适用性或不侵犯任何第三方知识产权的暗示担保。

这些资源可供使用 TI 产品进行设计的熟练开发人员使用。您将自行承担以下全部责任：(1) 针对您的应用选择合适的 TI 产品，(2) 设计、验证并测试您的应用，(3) 确保您的应用满足相应标准以及任何其他功能安全、信息安全、监管或其他要求。

这些资源如有变更，恕不另行通知。TI 授权您仅可将这些资源用于研发本资源所述的 TI 产品的应用。严禁对这些资源进行其他复制或展示。您无权使用任何其他 TI 知识产权或任何第三方知识产权。您应全额赔偿因在这些资源的使用中对 TI 及其代表造成的任何索赔、损害、成本、损失和债务，TI 对此概不负责。

TI 提供的产品受 [TI 的销售条款](#) 或 [ti.com](#) 上其他适用条款/TI 产品随附的其他适用条款的约束。TI 提供这些资源并不会扩展或以其他方式更改 TI 针对 TI 产品发布的适用的担保或担保免责声明。

TI 反对并拒绝您可能提出的任何其他或不同的条款。

邮寄地址：Texas Instruments, Post Office Box 655303, Dallas, Texas 75265

Copyright © 2024，德州仪器 (TI) 公司