

低 I_Q ，单升压双同步降压稳压器

 查询样品: **TPS43330A-Q1**

特性

- 符合汽车应用要求
- 具有符合 **AEC-Q100** 的下列结果:
 - 器件温度 1 级: **-40°C 至 +125°C** 的环境运行温度范围
 - 器件人体模型 (HBM) 静电放电 (ESD) 分类等级 **H2**
 - 器件充电器件模型 (CDM) ESD 分类等级 **C2**
- 两个同步降压控制器
- 一个预升压控制器
- 当启用升压时, 输入电压范围高达 **40V**, (瞬态电压高达 **60V**), 运行电压低至 **2V**
- 低功耗模式 I_Q : **30 μ A** (一个降压控制器打开), **35 μ A** (两个降压控制器打开)
- 低关断电流 I_{sh} < **4 μ A**
- 降压输出范围 **0.9 至 11V**
- 可选升压输出: **7V, 8.85V 或者 10V**
- 可编程频率和外部同步范围为 **150 至 600kHz**
- 独立的使能输入 (**ENA, ENB, ENC**)
- 轻负载时, 可选择强制持续模式或自动低功耗模式
- 感应电阻器或者电感器直流电阻 (**DCR**) 感测对于降压控制器
- 降压通道之间的异相开关
- 峰值栅极驱动电流 **1.5A**

- 耐热增强型 **38** 引脚散热薄型小外形尺寸封装 (**HTSSOP**)(**DAP**) **PowerPAD™** 封装

应用范围

- 汽车电子启动/停止、信息娱乐、导航仪表盘系统
- 工业和汽车用多轨直流配电系统和电子控制单元

说明

TPS43330A-Q1 包括两个电流模式同步降压控制器和一个电压模式升压控制器。此器件非常适合于作为对 I_Q 要求较低的预稳压器级, 并且适用于在遇到由意外事件引起的电源中断时, 需要不对系统造成损害的应用。集成升压控制器使得器件能够在输入低至 **2V** 时运行, 而又不会出现降压稳压器输出级的下降。在轻负载时, 可以启用降压控制器来在自动低功耗模式下运行, 消耗的静态电流仅为 **30 μ A**。

降压控制器有独立的软启动功能和电源正常指示器。降压控制器中的电流折返和升压控制器中的逐周期电流限制提供了外部金属氧化物半导体场效应晶体管 (MOSFET) 保护。开关频率可在 **150kHz 至 600kHz** 之间进行设定或者可将它与一个处于同一范围内的外部时钟同步。



图 1. 典型应用图



Please be aware that an important notice concerning availability, standard warranty, and use in critical applications of Texas Instruments semiconductor products and disclaimers thereto appears at the end of this data sheet.

PowerPAD is a trademark of Texas Instruments.

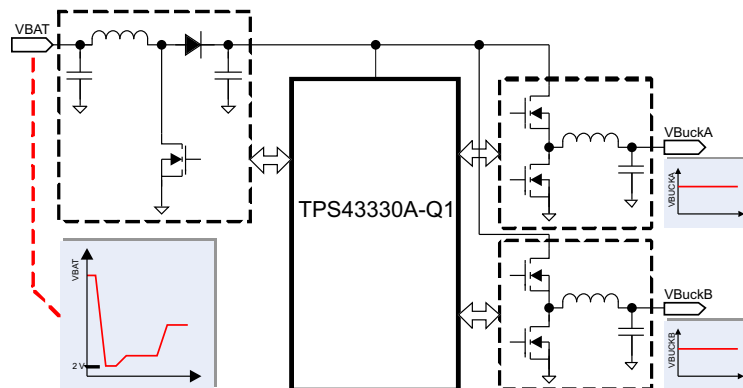
PRODUCTION DATA information is current as of publication date. Products conform to specifications per the terms of the Texas Instruments standard warranty. Production processing does not necessarily include testing of all parameters.

Copyright © 2013, Texas Instruments Incorporated
English Data Sheet: **SLVSC16**

PACKAGE AND ORDERING INFORMATION

For the most-current package and ordering information, see the Package Option Addendum at the end of this document, or see the TI Web site at www.ti.com.

Package drawings, thermal data, and symbolization are available at www.ti.com/packaging.



This integrated circuit can be damaged by ESD. Texas Instruments recommends that all integrated circuits be handled with appropriate precautions. Failure to observe proper handling and installation procedures can cause damage.

ESD damage can range from subtle performance degradation to complete device failure. Precision integrated circuits may be more susceptible to damage because very small parametric changes could cause the device not to meet its published specifications.

ABSOLUTE MAXIMUM RATINGS⁽¹⁾

		MIN	MAX	UNIT	
Voltage	Input voltage: VIN, VBAT	-0.3	60	V	
Voltage (buck function: BuckA and BuckB)	Ground: PGND-AGND, PGND-AGND	-0.3	0.3	V	
	Enable inputs: ENA, ENB	-0.3	60	V	
	Bootstrap inputs: CBA, CBB	-0.3	68	V	
	Bootstrap inputs: CBA-PHA, CBB-PHB	-0.3	8.8	V	
	Phase inputs: PHA, PHB	-0.7	60	V	
	Phase inputs: PHA, PHB (for 150 ns)	-1	60	V	
	Feedback inputs: FBA, FBB	-0.3	13	V	
	Error-amplifier outputs: COMPA, COMPB	-0.3	13	V	
	High-side MOSFET drivers: GA1-PHA, GB1-PHB	-0.3	8.8	V	
	Low-side MOSFET drivers: GA2-PGND, GB2-PGND	-0.3	8.8	V	
	Current-sense voltage: SA1, SA2, SB1, SB2	-0.3	13	V	
	Soft start: SSA, SSB	-0.3	13	V	
	Power-good outputs: PGA, PGB	-0.3	13	V	
	Power-good delay: DLYAB	-0.3	13	V	
Switching-frequency timing resistor: RT	-0.3	13	V		
SYNC, EXTSUP	-0.3	13	V		
Voltage (boost function)	Low-side MOSFET driver: GC1-PGND	-0.3	8.8	V	
	Error-amplifier output: COMPC	-0.3	13	V	
	Enable input: ENC	-0.3	13	V	
	Current-limit sense: DS	-0.3	60	V	
	Output-voltage select: DIV	-0.3	8.8	V	
Voltage (PMOS driver)	P-channel MOSFET driver: GC2	-0.3	60	V	
	P-channel MOSFET driver: VIN-GC2	-0.3	8.8	V	
	Gate-driver supply: VREG	-0.3	8.8	V	
Temperature	Junction temperature: T _J	-40	150	°C	
	Operating temperature: T _A	-40	125	°C	
	Storage temperature: T _{stg}	-55	165	°C	
Electrostatic discharge ratings	Human-body model (HBM) AEC-Q100 Classification Level H2	±2		kV	
	Charged-device model (CDM) AEC-Q100 Classification Level C2	VBAT, ENC, SYNC, VIN	±750		V
		All other pins	±500		
	Machine model (MM)	PGA, PGB	±150		
All other pins		±200			

(1) Stresses beyond those listed under *Absolute Maximum Ratings* may cause permanent damage to the device. These are stress ratings only, and functional operation of the device at these or any other conditions beyond those indicated under *Recommended Operating Conditions* is not implied. Exposure to absolute-maximum-rated conditions for extended periods may affect device reliability. All voltage values are with respect to AGND, unless otherwise specified.

THERMAL INFORMATION

THERMAL METRIC ⁽¹⁾		TPS4333x-Q1	
		DAP	UNIT
		38 PINS	
θ_{JA}	Junction-to-ambient thermal resistance ⁽²⁾	27.3	°C/W
θ_{JcTop}	Junction-to-case (top) thermal resistance ⁽³⁾	19.6	°C/W
θ_{JB}	Junction-to-board thermal resistance ⁽⁴⁾	15.9	°C/W
ψ_{JT}	Junction-to-top characterization parameter ⁽⁵⁾	0.24	°C/W
ψ_{JB}	Junction-to-board characterization parameter ⁽⁶⁾	6.6	°C/W
θ_{JcBot}	Junction-to-case (bottom) thermal resistance ⁽⁷⁾	1.2	°C/W

- (1) For more information about traditional and new thermal metrics, see the *IC Package Thermal Metrics* application report, [SPRA953](#).
- (2) The junction-to-ambient thermal resistance under natural convection is obtained in a simulation on a JEDEC-standard, high-K board, as specified in JESD51-7, in an environment described in JESD51-2a.
- (3) The junction-to-case (top) thermal resistance is obtained by simulating a cold plate test on the package top. No specific JEDEC-standard test exists, but a close description can be found in the ANSI SEMI standard G30-88.
- (4) The junction-to-board thermal resistance is obtained by simulating in an environment with a ring cold plate fixture to control the PCB temperature, as described in JESD51-8.
- (5) The junction-to-top characterization parameter, ψ_{JT} , estimates the junction temperature of a device in a real system and is extracted from the simulation data for obtaining θ_{JA} , using a procedure described in JESD51-2a (sections 6 and 7).
- (6) The junction-to-board characterization parameter, ψ_{JB} , estimates the junction temperature of a device in a real system and is extracted from the simulation data for obtaining θ_{JA} , using a procedure described in JESD51-2a (sections 6 and 7).
- (7) The junction-to-case (bottom) thermal resistance is obtained by simulating a cold plate test on the exposed (power) pad. No specific JEDEC standard test exists, but a close description can be found in the ANSI SEMI standard G30-88.

RECOMMENDED OPERATING CONDITIONS

		MIN	MAX	UNIT
Buck function: BuckA and BuckB voltage	Input voltage: VIN, VBAT	4	40	V
	Enable inputs: ENA, ENB	0	40	
	Boot inputs: CBA, CBB	4	48	
	Phase inputs: PHA, PHB	-0.6	40	
	Current-sense voltage: SA1, SA2, SB1, SB2	0	11	
	Power-good output: PGA, PGB	0	11	
	SYNC, EXTSUP	0	9	
Boost function	Enable input: ENC	0	9	V
	Voltage sense: DS		40	
	DIV	0	V _{REG}	
	Operating temperature: T _A	-40	125	

DC ELECTRICAL CHARACTERISTICS

$V_{IN} = 8\text{ V to }18\text{ V}$, $T_J = -40^\circ\text{C to }+150^\circ\text{C}$ (unless otherwise noted)

NO.	PARAMETER	TEST CONDITIONS	MIN	TYP	MAX	UNIT		
1.0 Input Supply								
1.1	V_{BAT}	Supply voltage	Boost controller enabled, after satisfying initial start-up condition		2	40	V	
1.2	V_{IN}	Input voltage required for device on initial start-up			6.5	40	V	
		Buck regulator operating range after initial start-up			4	40		
1.3	$V_{IN(UV)}$	Buck undervoltage lockout	V_{IN} falling. After a reset, initial start-up conditions may apply. ⁽¹⁾		3.5	3.6	3.8	V
			V_{IN} rising. After a reset, initial start-up conditions may apply. ⁽¹⁾			3.8	4	V
1.4	V_{BOOST_UNLOCK}	Boost unlock threshold	V_{BAT} rising		8.2	8.5	8.8	V
1.5	I_{Q_LPM}	LPM quiescent current: ⁽²⁾	$V_{IN} = 13\text{ V}$, BuckA: LPM, BuckB: off, $T_A = 25^\circ\text{C}$			30	40	μA
			$V_{IN} = 13\text{ V}$, BuckB: LPM, BuckA: off, $T_A = 25^\circ\text{C}$					
			$V_{IN} = 13\text{ V}$, BuckA, B: LPM, $T_A = 25^\circ\text{C}$			35	45	μA
1.6	I_{Q_LPM}	LPM quiescent current: ⁽²⁾	$V_{IN} = 13\text{ V}$, BuckA: LPM, BuckB: off, $T_A = 125^\circ\text{C}$			40	50	μA
			$V_{IN} = 13\text{ V}$, BuckB: LPM, BuckA: off, $T_A = 125^\circ\text{C}$					
			$V_{IN} = 13\text{ V}$, BuckA, B: LPM, $T_A = 125^\circ\text{C}$			45	55	μA
1.7	I_{Q_NRM}	Quiescent current: normal (PWM) mode ⁽²⁾	SYNC = HIGH, $T_A = 25^\circ\text{C}$					mA
			$V_{IN} = 13\text{ V}$, BuckA: CCM, BuckB: off, $T_A = 25^\circ\text{C}$			4.85	5.3	
			$V_{IN} = 13\text{ V}$, BuckB: CCM, BuckA: off, $T_A = 25^\circ\text{C}$					
			$V_{IN} = 13\text{ V}$, BuckA, B: CCM, $T_A = 25^\circ\text{C}$			7	7.6	
1.8	I_{Q_NRM}	Quiescent current: normal (PWM) mode ⁽²⁾	SYNC = HIGH, $T_A = 125^\circ\text{C}$					mA
			$V_{IN} = 13\text{ V}$, BuckA: CCM, BuckB: off, $T_A = 125^\circ\text{C}$			5	5.5	
			$V_{IN} = 13\text{ V}$, BuckB: CCM, BuckA: off, $T_A = 125^\circ\text{C}$					
			$V_{IN} = 13\text{ V}$, BuckA, B: CCM, $T_A = 125^\circ\text{C}$			7.5	8	
1.9	I_{bat_sh}	Shutdown current	BuckA, B: off, $V_{BAT} = 13\text{ V}$, $T_A = 25^\circ\text{C}$			2.5	4	μA
1.10	I_{bat_sh}	Shutdown current	BuckA, B: off, $V_{BAT} = 13\text{ V}$, $T_A = 125^\circ\text{C}$			3	5	μA
1.11	$V_{IN_LPMexit}$	V_{IN} level to exit LPM	V_{IN} falling		7.7	8	8.3	V
1.12	$V_{IN_LPMentry}$	V_{IN} level to enable entering LPM	V_{IN} rising		8.2	8.5	8.8	V
1.13	V_{IN_LPMhys}	Hysteresis	V_{IN} rising or falling		0.4	0.5	0.6	V
2.0 Input Voltage V_{BAT} - Undervoltage Lockout								
2.1	$V_{BAT(UV)}$	Boost-input undervoltage	V_{BAT} falling. After a reset, initial start-up conditions may apply. ⁽¹⁾		1.8	1.9	2	V
			V_{BAT} rising. After a reset, initial start-up conditions may apply. ⁽¹⁾		2.4	2.5	2.6	V
2.2	$UVLO_{Hys}$	Hysteresis			500	600	700	mV
2.3	$UVLO_{filter}$	Filter time				5		μs
3.0 Input Voltage V_{IN} - Overvoltage Lockout								
3.1	V_{OVLO}	Overvoltage shutdown	V_{IN} rising		45	46	47	V
			V_{IN} falling		43	44	45	
3.2	$OVLO_{Hys}$	Hysteresis			1	2	3	V
3.3	$OVLO_{filter}$	Filter time				5		μs
4.0 Boost Controller								
4.1	$V_{boost7V}$	Boost $V_{OUT} = 7\text{ V}$	DIV = low, $V_{BAT} = 2\text{ V to }7\text{ V}$		6.8	7	7.3	V
4.2	$V_{boost7V-th}$	Boost-enable threshold	Boost $V_{OUT} = 7\text{ V}$, V_{BAT} falling		7.5	8	8.5	V
		Boost-disable threshold	Boost $V_{OUT} = 7\text{ V}$, V_{BAT} rising		8	8.5	9	
		Boost hysteresis	Boost $V_{OUT} = 7\text{ V}$, V_{BAT} rising or falling		0.4	0.5	0.6	
4.3	$V_{boost10V}$	Boost $V_{OUT} = 10\text{ V}$	DIV = open, $V_{BAT} = 2\text{ V to }10\text{ V}$		9.7	10	10.4	V

(1) If V_{BAT} and V_{REG} remain adequate, the buck can continue to operate if V_{IN} is $> 3.8\text{ V}$.

(2) Quiescent current specification is non-switching current consumption without including the current in the external-feedback resistor divider.

DC ELECTRICAL CHARACTERISTICS (continued)
 $V_{IN} = 8\text{ V to }18\text{ V}$, $T_J = -40^\circ\text{C to }+150^\circ\text{C}$ (unless otherwise noted)

NO.	PARAMETER		TEST CONDITIONS	MIN	TYP	MAX	UNIT
4.4	$V_{\text{boost}10\text{V-th}}$	Boost-enable threshold	Boost $V_{\text{OUT}} = 10\text{ V}$, V_{BAT} falling	10.5	11	11.5	V
		Boost-disable threshold	Boost $V_{\text{OUT}} = 10\text{ V}$, V_{BAT} rising	11	11.5	12	
		Boost hysteresis	Boost $V_{\text{OUT}} = 10\text{ V}$, V_{BAT} rising or falling	0.4	0.5	0.6	
4.5	$V_{\text{boost}8.85\text{V}}$	Boost $V_{\text{OUT}} = 8.85\text{ V}$	$\text{DIV} = V_{\text{REG}}$, $V_{\text{BAT}} = 2\text{ V to }8.85\text{ V}$	8.35	8.85	9.35	V
4.6	$V_{\text{boost}8.85\text{V-th}}$	Boost-enable threshold	Boost $V_{\text{OUT}} = 8.85\text{ V}$, V_{BAT} falling	9.15	9.85	10.45	V
		Boost-disable threshold	Boost $V_{\text{OUT}} = 8.85\text{ V}$, V_{BAT} rising	9.65	10.35	10.85	
		Boost hysteresis	Boost $V_{\text{OUT}} = 8.85\text{ V}$, V_{BAT} rising or falling	0.4	0.5	0.6	
Boost-Switch Current Limit							
4.7	V_{DS}	Current-limit sensing	DS input with respect to PGND A	0.175	0.2	0.225	V
4.8	t_{DS}	Leading-edge blanking			200		ns
Gate Driver for Boost Controller							
4.9	$I_{\text{GC1 Peak}}$	Gate-driver peak current			1.5		A
4.10	$r_{\text{DS(on)}}$	Source and sink driver	$V_{\text{REG}} = 5.8\text{ V}$, I_{GC1} current = 200 mA			2	Ω
Gate Driver for PMOS							
4.11	$r_{\text{DS(on)}}$	PMOS OFF			10	20	Ω
4.12	$I_{\text{PMOS_ON}}$	Gate current	$V_{\text{IN}} = 13.5\text{ V}$, $V_{\text{GS}} = -5\text{ V}$	10			mA
4.13	$t_{\text{delay_ON}}$	Turnon delay	$C = 10\text{ nF}$		5	10	μs
Boost-Controller Switching Frequency							
4.14	$f_{\text{sw-Boost}}$	Boost switching frequency			$f_{\text{SW_Buck}} / 2$		kHz
4.15	D_{Boost}	Boost duty cycle			90%		
Error Amplifier (OTA) for Boost Converters							
4.16	G_{mBOOST}	Forward transconductance	$V_{\text{BAT}} = 12\text{ V}$	0.8		1.35	mS
			$V_{\text{BAT}} = 5\text{ V}$	0.35		0.65	
5.0	Buck Controllers						
5.1	V_{BuckA} OR V_{BuckB}	Adjustable output-voltage range		0.9		11	V
5.2	$V_{\text{ref, NRM}}$	Internal reference and tolerance voltage in normal mode	Measure FBX pin	0.792	0.8	0.808	V
				-1%		1%	
5.3	$V_{\text{ref, LPM}}$	Internal reference and tolerance voltage in low-power mode	Measure FBX pin	0.784	0.8	0.816	V
				-2%		2%	
5.4	V_{sense}	V sense for forward-current limit in CCM	Measured across Sx1 and Sx2, FBx = 0.75 V (low duty-cycle)	60	75	90	mV
5.5		V sense for reverse-current limit in CCM	Measured across Sx1 and Sx2, FBx = 1 V	-65	-37.5	-23	mV
5.6	$V_{\text{I-Foldback}}$	V sense for output short	Measured across Sx1 and Sx2, FBx = 0 V	17	32.5	48	mV
5.7	t_{dead}	Shoot-through delay, blanking time			20		ns
5.8	DC_{NRM}	High-side minimum on-time			100		ns
		Maximum duty cycle (digitally controlled)			98.75%		
5.9	DC_{LPM}	Duty cycle, LPM			80%		
5.10	$I_{\text{LPM_Entry}}$	LPM entry-threshold load current as fraction of maximum set load current			1%	(3)	
	$I_{\text{LPM_Exit}}$	LPM exit-threshold load current as fraction of maximum set load current		(3)	10%		
High-Side External NMOS Gate Drivers for Buck Controller							
5.11	$I_{\text{GX1_peak}}$	Gate-driver peak current			1.5		A
5.12	$r_{\text{DS(on)}}$	Source and sink driver	$V_{\text{REG}} = 5.8\text{ V}$, I_{GX1} current = 200 mA			2	Ω

(3) The exit threshold specification is to be always higher than the entry threshold.

DC ELECTRICAL CHARACTERISTICS (continued)
 $V_{IN} = 8\text{ V to }18\text{ V}$, $T_J = -40^\circ\text{C to }+150^\circ\text{C}$ (unless otherwise noted)

NO.	PARAMETER		TEST CONDITIONS	MIN	TYP	MAX	UNIT
Low-Side NMOS Gate Drivers for Buck Controller							
5.13	I_{GX2_peak}	Gate-driver peak current			1.5		A
5.14	R_{DS_ON}	Source and sink driver	$V_{REG} = 5.8\text{ V}$, I_{GX2} current = 200 mA			2	Ω
Error Amplifier (OTA) for Buck Converters							
5.15	G_{mBUCK}	Transconductance	COMP _A , COMP _B = 0.8 V, source/sink = 5 μ A, test in feedback loop	0.72	1	1.35	mS
6.0	Digital Inputs: ENA, ENB, ENC, SYNC						
6.1	V_{IH}	Higher threshold	$V_{IN} = 13\text{ V}$	1.7			V
6.2	V_{IL}	Lower threshold	$V_{IN} = 13\text{ V}$			0.7	V
6.3	R_{IH_SYNC}	Pulldown resistance on SYNC	$V_{SYNC} = 5\text{ V}$		500		k Ω
6.4	R_{IL_ENC}	Pulldown resistance on ENC	$V_{ENC} = 5\text{ V}$		500		k Ω
6.5	I_{IL_ENx}	Pullup current source on ENA, ENB	$V_{ENx} = 0\text{ V}$		0.5	2	μ A
7.0	Boost Output Voltage: DIV						
7.1	V_{IH_DIV}	Higher threshold	$V_{REG} = 5.8\text{ V}$	$V_{REG} - 0.2$			V
7.2	V_{IL_DIV}	Lower threshold				0.2	V
7.3	V_{oz_DIV}	Voltage on DIV if unconnected	Voltage on DIV if unconnected		$V_{REG} / 2$		V
8.0	Switching Parameter – Buck DC-DC Controllers						
8.1	f_{SW_Buck}	Buck switching frequency	RT pin: GND	360	400	440	kHz
8.2	f_{SW_Buck}	Buck switching frequency	RT pin: 60-k Ω external resistor	360	400	440	kHz
8.3	f_{SW_adj}	Buck adjustable range with external resistor	RT pin: external resistor	150		600	kHz
8.4	f_{SYNC}	Buck synchronization range	External clock input	150		600	kHz
9.0	Internal Gate-Driver Supply						
9.1	V_{REG}	Internal regulated supply	$V_{IN} = 8\text{ V to }18\text{ V}$, $V_{EXTSUP} = 0\text{ V}$, SYNC = high	5.5	5.8	6.1	V
		Load regulation	$I_{VREG} = 0\text{ mA to }100\text{ mA}$, $V_{EXTSUP} = 0\text{ V}$, SYNC = high		0.2%	1%	
9.2	$V_{REG(EXTSUP)}$	Internal regulated supply	$V_{EXTSUP} = 8.5\text{ V}$	7.2	7.5	7.8	V
		Load regulation	$I_{EXTSUP} = 0\text{ mA to }125\text{ mA}$, SYNC = High $V_{EXTSUP} = 8.5\text{ V to }13\text{ V}$		0.2%	1%	
9.3	$V_{EXTSUP-th}$	EXTSUP switch-over voltage threshold	$I_{VREG} = 0\text{ mA to }100\text{ mA}$, V_{EXTSUP} ramping positive	4.4	4.6	4.8	V
9.4	$V_{EXTSUP-Hys}$	EXTSUP switch-over hysteresis		150		250	mV
9.5	$I_{VREG-Limit}$	Current limit on VREG	$V_{EXTSUP} = 0\text{ V}$, normal mode as well as LPM	100		400	mA
9.6	$I_{VREG_EXTSUP-Limit}$	Current limit on VREG when using EXTSUP	$I_{VREG} = 0\text{ mA to }100\text{ mA}$, $V_{EXTSUP} = 8.5\text{ V}$, SYNC = High	125		400	mA
10.0	Soft Start						
10.1	I_{SSx}	Soft-start source current	V_{SSA} and $V_{SSB} = 0\text{ V}$	40	50	60	μ A
11.0	Oscillator (RT)						
11.1	V_{RT}	Oscillator reference voltage			1.2		V
12.0	Power Good / Delay						
12.1	PG_{th1}	Power-good threshold	FBx falling	-5%	-7%	-9%	
12.2	PG_{hys}	Hysteresis			2%		
12.3	PG_{drop}	Voltage drop	$I_{PGA} = 5\text{ mA}$			450	mV
12.4			$I_{PGA} = 1\text{ mA}$			100	mV
12.5	PG_{leak}	Power-good leakage	$V_{SX2} = V_{PGx} = 13\text{ V}$			1	μ A
12.6	$t_{deglitch}$	Power-good deglitch time		2		16	μ s
12.7	t_{delay}	Reset delay	External capacitor = 1 nF $V_{BuckX} < PG_{th1}$		1		ms
12.8	t_{delay_fix}	Fixed reset delay	No external capacitor, pin open		20	50	μ s
12.9	I_{OH}	Activate current source (current to charge external capacitor)		30	40	50	μ A
12.10	I_{IL}	Activate current sink (current to discharge external capacitor)		30	40	50	μ A

DC ELECTRICAL CHARACTERISTICS (continued)
 $V_{IN} = 8\text{ V to }18\text{ V}$, $T_J = -40^{\circ}\text{C to }+150^{\circ}\text{C}$ (unless otherwise noted)

NO.	PARAMETER		TEST CONDITIONS	MIN	TYP	MAX	UNIT
13.0	Overtemperature Protection						
13.1	T_{shutdown}	Junction-temperature shutdown threshold		150	165		$^{\circ}\text{C}$
13.2	T_{hys}	Junction-temperature hysteresis			15		$^{\circ}\text{C}$

DEVICE INFORMATION

DAP PACKAGE
(TOP VIEW)

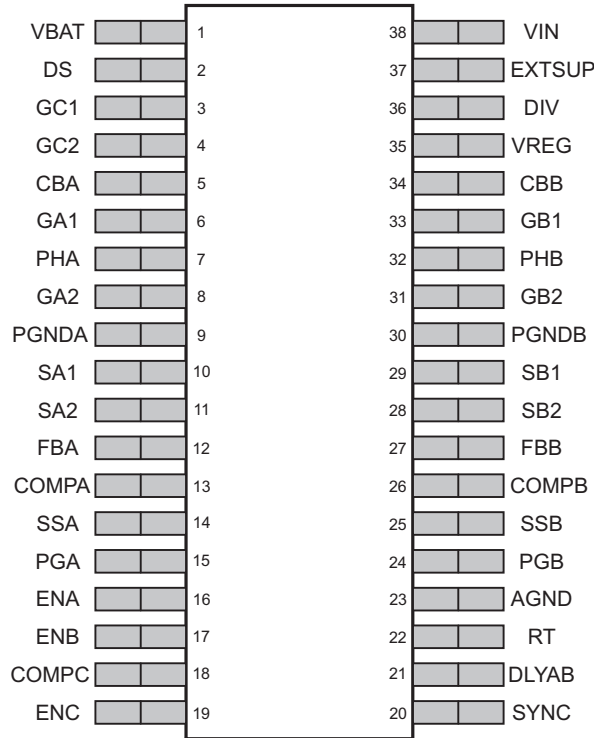

PIN FUNCTIONS

NAME	NO.	I/O	DESCRIPTION
AGND	23	O	Analog ground reference
CBA	5	I	A capacitor on this pin acts as the voltage supply for the high-side N-channel MOSFET gate-drive circuitry in buck controller BuckA. When the buck is in a dropout condition, the device automatically reduces the duty cycle of the high-side MOSFET to approximately 95% on every fourth cycle to allow the capacitor to recharge.
CBB	34	I	A capacitor on this pin acts as the voltage supply for the high-side N-channel MOSFET gate-drive circuitry in buck controller BuckB. When the buck is in a dropout condition, the device automatically reduces the duty cycle of the high-side MOSFET to approximately 95% on every fourth cycle to allow the capacitor to recharge.
COMPA	13	O	Error amplifier output of BuckA and compensation node for voltage-loop stability. The voltage at this node sets the target for the peak current through the inductor of BuckA. Clamping this voltage on the upper and lower ends provides current-limit protection for the external MOSFETs.
COMPB	26	O	Error amplifier output of BuckB and compensation node for voltage-loop stability. The voltage at this node sets the target for the peak current through the inductor of BuckB. Clamping this voltage on the upper and lower ends provides current-limit protection for the external MOSFETs.
COMPC	18	O	Error-amplifier output and loop-compensation node of the boost regulator
DIV	36	I	The status of this pin defines the output voltage of the boost regulator. A high input regulates the boost converter at 8.85 V, a low input sets the value at 7 V, and a floating pin sets 10 V. NOTE: DIV = high and ENC = high inhibits low-power mode on the bucks.
DLYAB	21	O	The capacitor at the DLYAB pin sets the power-good delay interval used to de-glitch the outputs of the power-good comparators. Leaving this pin open sets the power-good delay to an internal default value of 20 μs typical.
DS	2	I	This input monitors the voltage on the external boost-converter low-side MOSFET for overcurrent protection. An alternative connection for better noise immunity is to a sense resistor between the source of the low-side MOSFET and ground via a filter network.
ENA	16	I	Enable input for BuckA (active-high with an internal pullup current source). An input voltage higher than 1.7 V enables the controller, whereas an input voltage lower than 0.7 V disables the controller. When both ENA and ENB are low, the device shuts down and consumes less than 4 μA of current.

PIN FUNCTIONS (continued)

NAME	NO.	I/O	DESCRIPTION
ENB	17	I	Enable input for BuckB (active-high with an internal pullup current source). An input voltage higher than 1.7 V enables the controller, whereas an input voltage lower than 0.7 V disables the controller. When both ENA and ENB are low, the device shuts down and consumes less than 4 μ A of current. NOTE: DIV = high and ENC = high inhibits low-power mode on the bucks.
ENC	19	I	This input enables and disables the boost regulator. An input voltage higher than 1.7 V enables the controller. Voltages lower than 0.7 V disable the controller. Because this pin provides an internal pulldown resistor (500 k Ω), enabling the boost function requires pulling it high. When enabled, the controller starts switching as soon as V_{BAT} falls below the boost threshold, depending upon the programmed output voltage.
EXTSUP	37	I	One can use EXTSUP to supply the VREG regulator from one of the TPS43330A-Q1 buck regulator rails to reduce power dissipation in cases where there is an expectation of high V_{IN} . If EXTSUP is unused, leave the pin open without a capacitor installed.
FBA	12	I	Feedback voltage pin for BuckA. The buck controller regulates the feedback voltage to the internal reference of 0.8 V. A suitable resistor divider network between the buck output and the feedback pin sets the desired output voltage.
FBB	27	I	Feedback voltage pin for BuckB. The buck controller regulates the feedback voltage to the internal reference of 0.8 V. A suitable resistor-divider network between the buck output and the feedback pin sets the desired output voltage.
GA1	6	O	This output drives the external high-side N-channel MOSFET for buck regulator BuckA. The output provides high peak currents to drive capacitive loads. The gate-drive reference is to a floating ground provided by PHA that has a voltage swing provided by CBA.
GA2	8	O	This output drives the external low-side N-channel MOSFET for buck regulator BuckA. The output provides high peak currents to drive capacitive loads. VREG provides the voltage swing on this pin.
GB1	33	O	This output drives the external high-side N-channel MOSFET for buck regulator BuckB. The output provides high peak currents to drive capacitive loads. The gate-drive reference is to a floating ground provided by PHB that has a voltage swing provided by CBB.
GB2	31	O	This output drives the external low-side N-channel MOSFET for buck regulator BuckB. The output provides high peak currents to drive capacitive loads. VREG provides the voltage swing on this pin.
GC1	3	O	This output drives an external low-side N-channel MOSFET for the boost regulator. This output provides high peak currents to drive capacitive loads. VREG provides the voltage swing on this pin.
GC2	4	O	This pin makes a floating output drive available to control the external P-channel MOSFET. This MOSFET bypasses the boost rectifier diode or a reverse-protection diode when the boost status is non-switching or disabled, and thus reduce power losses.
PGA	15	O	Open-drain power-good indicator pin for BuckA. An internal power-good comparator monitors the voltage at the feedback pin and pulls this output low when the output voltage falls below 93% of the set value, or if either V_{IN} or V_{BAT} drops below the respective undervoltage threshold.
PGB	24	O	Open-drain power-good indicator pin for BuckB. An internal power-good comparator monitors the voltage at the feedback pin and pulls this output low when the output voltage falls below 93% of the set value, or if either V_{IN} or V_{BAT} drops below the respective undervoltage threshold.
PGNDA	9	O	Power-ground connection to the source of the low-side N-channel MOSFETs of BuckA
PGNDB	30	O	Power-ground connection to the source of the low-side N-channel MOSFETs of BuckB
PHA	7	O	Switching terminal of buck regulator BuckA, providing a floating ground reference for the high-side MOSFET gate-driver circuitry. PHA senses current reversal in the inductor when discontinuous-mode operation is desired.
PHB	32	O	Switching terminal of buck regulator BuckB, providing a floating ground reference for the high-side MOSFET gate-driver circuitry. PHB senses current reversal in the inductor when discontinuous-mode operation is desired.
RT	22	O	Connecting a resistor to ground on this pin sets the operational switching frequency of the buck and boost controllers. A short circuit to ground on this pin defaults operation to 400 kHz for the buck controllers and 200 kHz for the boost controller.
SA1	10	I	High-impedance differential-voltage inputs from the current-sense element (sense resistor or inductor DCR) for each buck controller. Choose the current-sense element to set the maximum current through the inductor based on the current-limit threshold (subject to tolerances) and considering the typical characteristics across duty cycle and V_{IN} . (SA1 positive node, SA2 negative node).
SA2	11	I	
SB1	29	I	High-impedance differential voltage inputs from the current-sense element (sense resistor or inductor DCR) for each buck controller. Choose the current-sense element to set the maximum current through the inductor based on the current-limit threshold (subject to tolerances) and considering the typical characteristics across duty cycle and V_{IN} . (SB1 positive node, SB2 negative node).
SB2	28	I	
SSA	14	O	Soft-start or tracking input for buck controller BuckA. The buck controller regulates the FBA voltage to the lower of 0.8 V or the SSA pin voltage. An internal pullup current source of 50 μ A is present at the pin, and an appropriate capacitor connected here sets the soft-start ramp interval. Alternatively, a resistor divider connected to another supply provides a tracking input to this pin.

PIN FUNCTIONS (continued)

NAME	NO.	I/O	DESCRIPTION
SSB	25	O	Soft-start or tracking input for buck controller BuckB. The buck controller regulates the FBB voltage to the lower of 0.8 V or the SSB pin voltage. An internal pullup current source of 50 μ A is present at the pin, and an appropriate capacitor connected here sets the soft-start ramp interval. Alternatively, a resistor divider connected to another supply provides a tracking input to this pin.
SYNC	20	I	If an external clock is present on this pin, the device detects it and the internal PLL locks onto the external clock, overriding the internal oscillator frequency. The device synchronizes frequencies from 150 to 600 kHz. A high-logic level on this pin ensures forced continuous-mode operation of the buck controllers and inhibits transition to low-power mode. An open or low allows discontinuous-mode operation and entry into low-power mode at light loads.
VBAT	1	I	Battery input sense for the boost controller. If, with the boost controller enabled, the voltage at VBAT falls below the boost threshold, the device activates the boost controller and regulates the voltage at VIN to the programmed boost output voltage.
VIN	38	I	Main Input pin. VIN is the buck-controller input pin as well as the output of the boost regulator. Additionally, VIN powers the internal control circuits of the device.
VREG	35	O	The device requires an external capacitor on this pin to provide a regulated supply for the gate drivers of the buck and boost controllers. TI recommends capacitance on the order of 4.7 μ F. The regulator obtains power from either VIN or EXTSUP. This pin has current-limit protection; do not use it to drive any other loads.

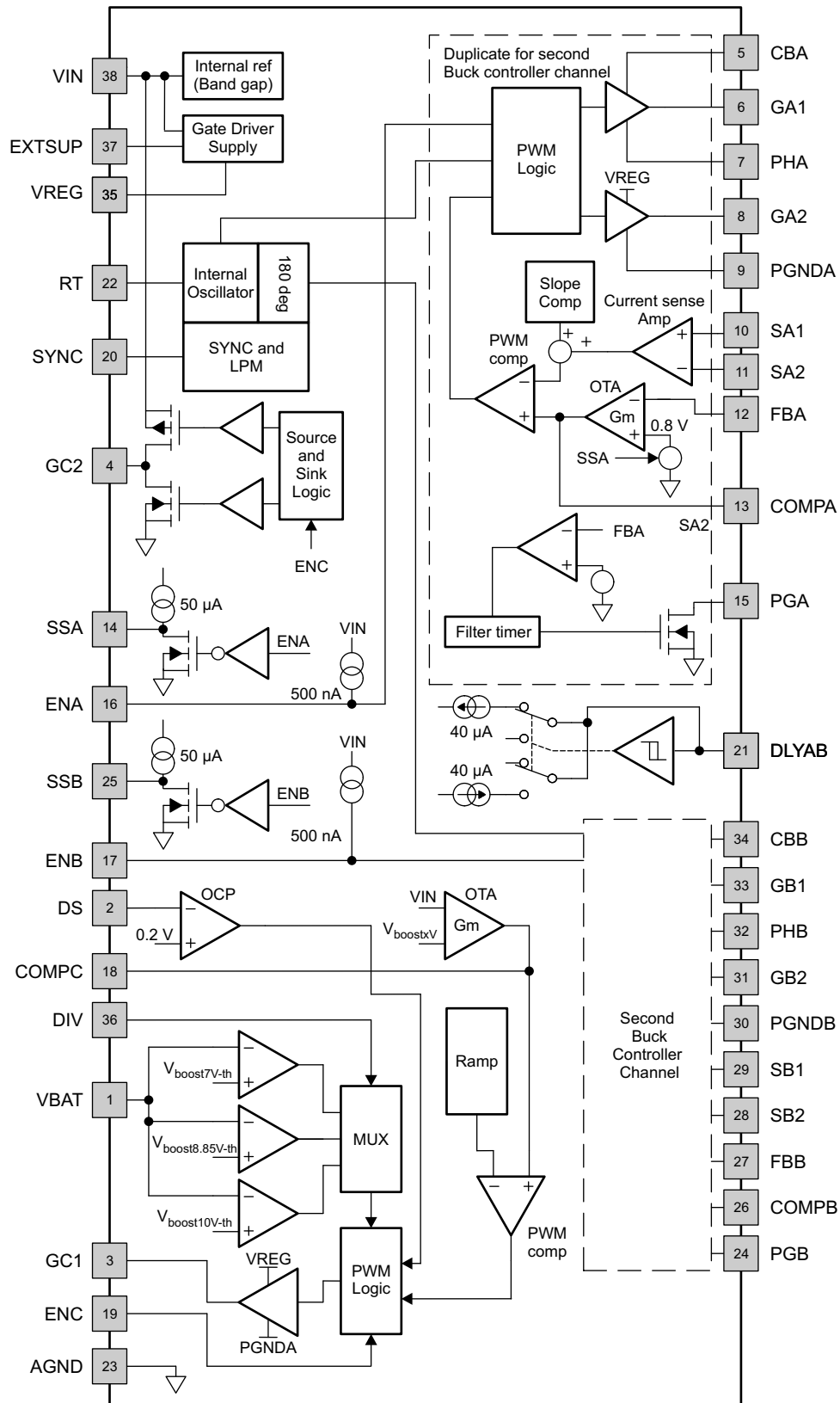
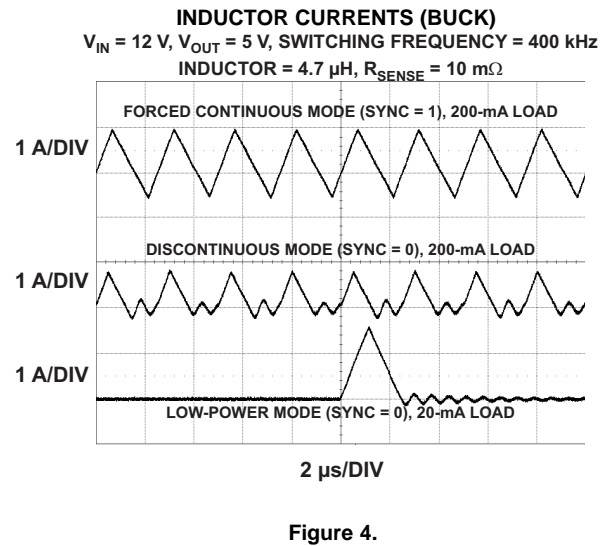
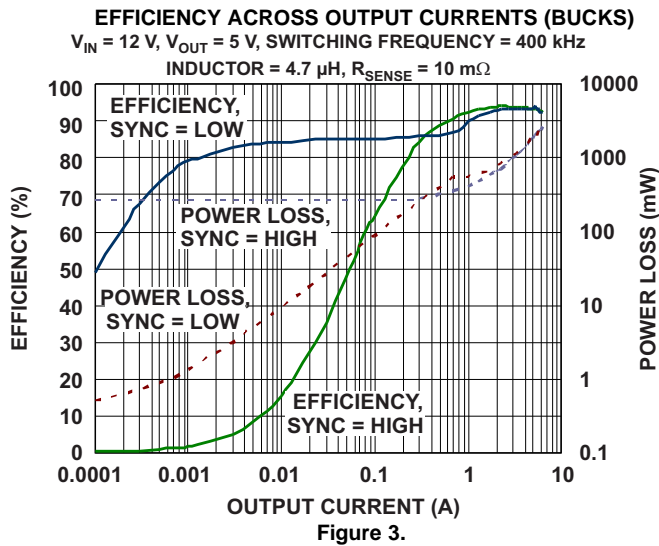
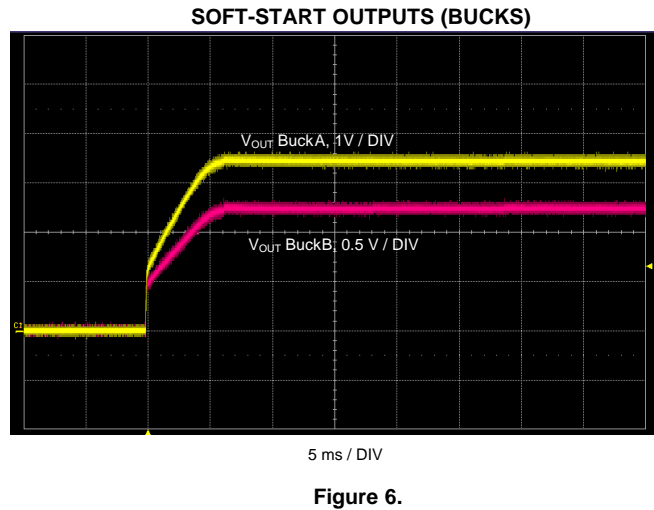
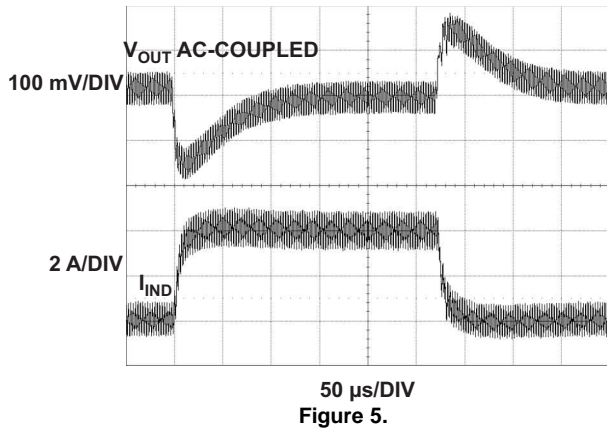

Figure 2. Functional Block Diagram

TYPICAL CHARACTERISTICS



BUCK LOAD STEP: FORCED CONTINUOUS MODE
 (0 TO 4 A AT 2.5 A/ μs)
 $V_{IN} = 12\text{ V}$, $V_{OUT} = 5\text{ V}$, SWITCHING FREQUENCY = 400 kHz
 INDUCTOR = 4.7 μH , $R_{SENSE} = 10\text{ m}\Omega$



BUCK LOAD STEP: LOW-POWER-MODE ENTRY
 (4 A TO 90 mA AT 2.5 A/ μs)
 $V_{IN} = 12\text{ V}$, $V_{OUT} = 5\text{ V}$, SWITCHING FREQUENCY = 400 kHz
 INDUCTOR = 4.7 μH , $R_{SENSE} = 10\text{ m}\Omega$

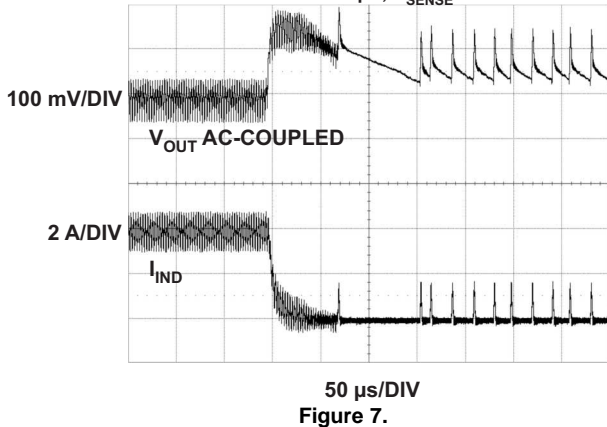

BUCK LOAD STEP: LOW-POWER-MODE EXIT
 (90 mA TO 4 A AT 2.5 A/ μs)
 $V_{IN} = 12\text{ V}$, $V_{OUT} = 5\text{ V}$, SWITCHING FREQUENCY = 400 kHz
 INDUCTOR = 4.7 μH , $R_{SENSE} = 10\text{ m}\Omega$

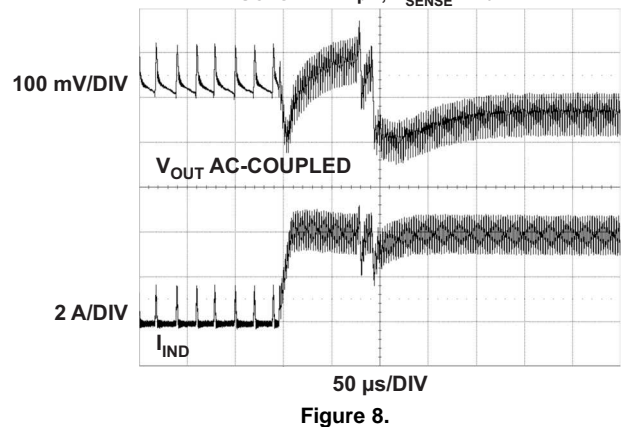

TYPICAL CHARACTERISTICS (continued)

EFFICIENCY ACROSS OUTPUT CURRENTS (BOOST)
 V_{IN} (BOOST OUTPUT) = 10 V, SWITCHING FREQUENCY = 200 kHz,
 INDUCTOR = 1 μ H, R_{SENSE} = 7.5 m Ω

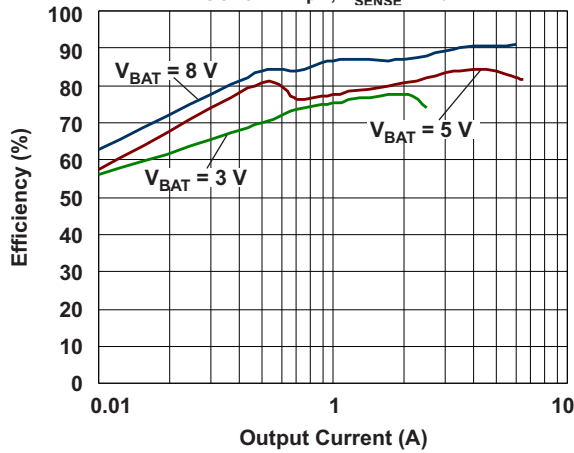

Figure 9.

LOAD STEP RESPONSE (BOOST)
(0 TO 5 A AT 10 A/ μ s)

V_{BAT} (BOOST INPUT) = 5 V, V_{IN} (BOOST OUTPUT) = 10 V,
 SWITCHING FREQUENCY = 200 KHz, INDUCTOR = 680 nH,
 R_{SENSE} = 10 m Ω , C_{IN} = 440 μ F, C_{OUT} = 660 μ F



Figure 10.

CRANKING-PULSE BOOST RESPONSE
(12 V TO 3 V IN 1 ms AT BUCK OUTPUTS 7.5 AND 11.5 W)
 V_{IN} (BOOST OUTPUT) = 10 V, BuckA = 5 V AT 1.5 A,
 BuckB = 3.3 V AT 3.5 A, SWITCHING FREQUENCY = 200 kHz,
 INDUCTOR = 1 μ H, R_{SENSE} = 7.5 m Ω , C_{IN} = 440 μ F, C_{OUT} = 660 μ F

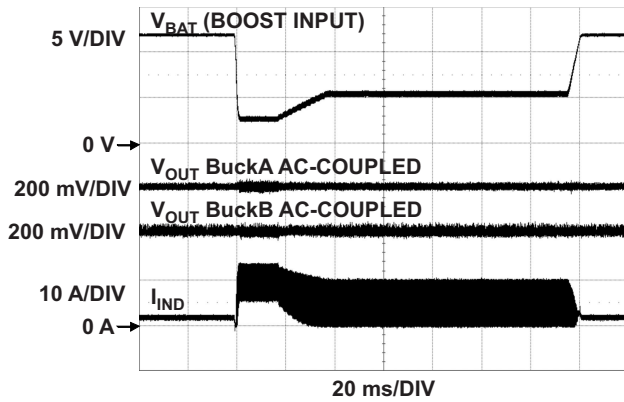

Figure 11.

CRANKING-PULSE BOOST RESPONSE
(12 V TO 4 V IN 1 ms AT BOOST DIRECT OUTPUT 25 W)
 V_{IN} (BOOST OUTPUT) = 10 V, BuckA = 5 V AT 1.5 A,
 BuckB = 3.3V AT 3.5A, SWITCHING FREQUENCY = 200 kHz,
 INDUCTOR = 1 μ H, R_{SENSE} = 7.5 m Ω , C_{IN} = 440 μ F, C_{OUT} = 660 μ F

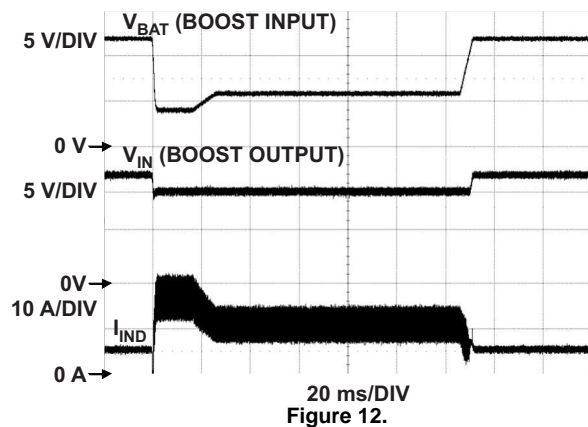

Figure 12.

INDUCTOR CURRENTS (BOOST)
 V_{BAT} (BOOST INPUT) = 5 V, V_{IN} (BOOST OUTPUT) = 10 V,
 SWITCHING FREQUENCY = 200 kHz, INDUCTOR = 1 μ H,
 R_{SENSE} = 7.5 m Ω , C_{IN} = 440 μ F, C_{OUT} = 660 μ F

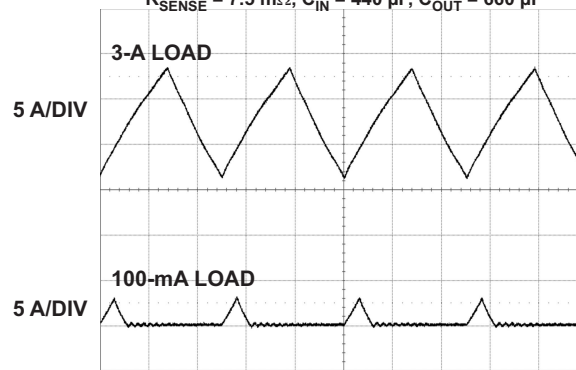

Figure 13.

TYPICAL CHARACTERISTICS (continued)

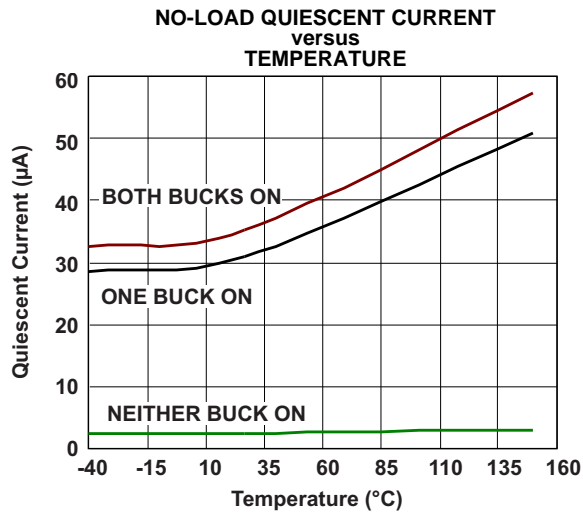

Figure 14.

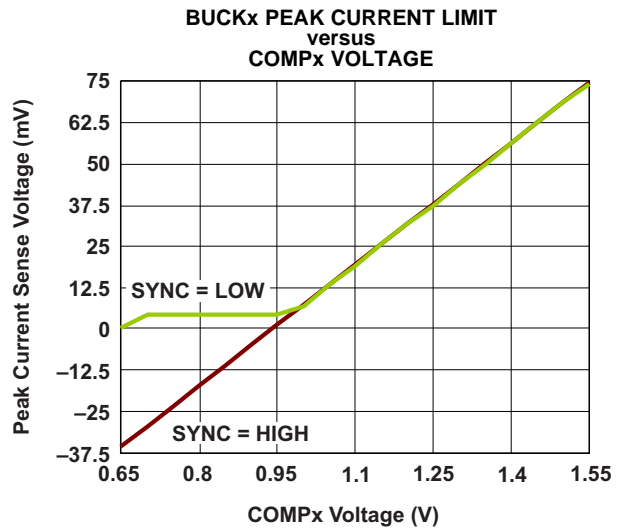

Figure 15.

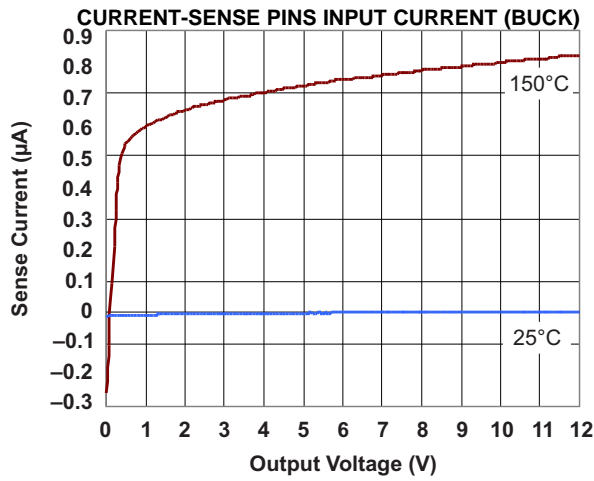

Figure 16.

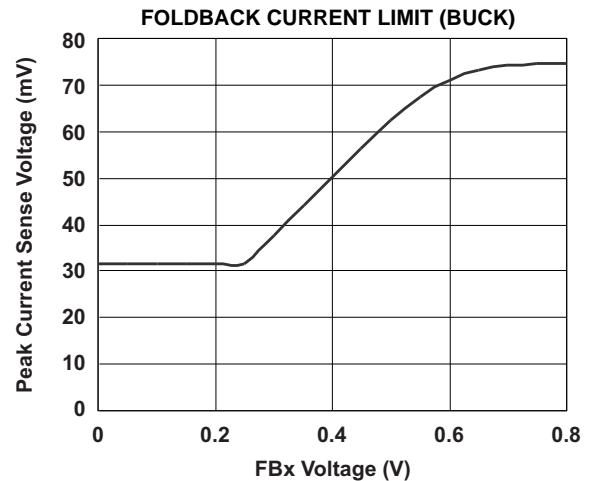

Figure 17.

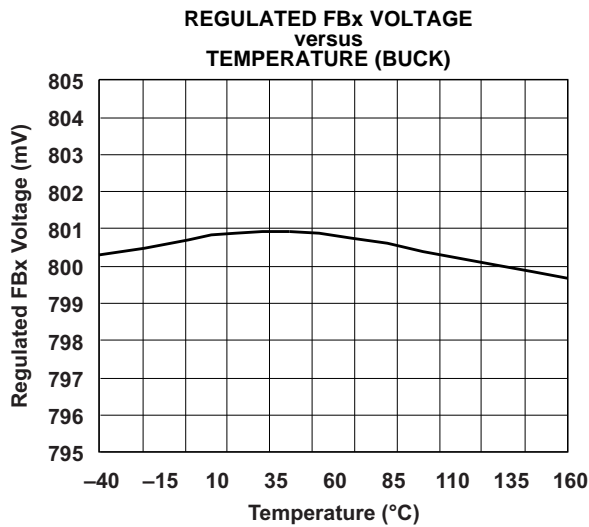

Figure 18.

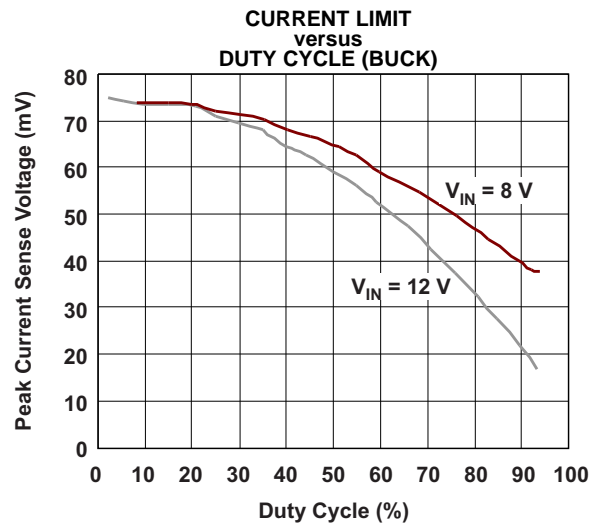

Figure 19.

DETAILED DESCRIPTION

BUCK CONTROLLERS: NORMAL MODE PWM OPERATION

Frequency Selection and External Synchronization

The buck controllers operate using constant-frequency peak-current-mode control for optimal transient behavior and ease of component choices. The switching frequency is programmable between 150 and 600 kHz, depending upon the resistor value at the RT pin. A short-circuit to ground at this pin sets the default switching frequency to 400 kHz. Using a resistor at RT, set another frequency according to [Equation 1](#).

$$f_{\text{SW}} = \frac{X}{RT} \quad (X = 24 \text{ k}\Omega \times \text{MHz})$$

$$f_{\text{SW}} = 24 \times \frac{10^9}{RT} \quad (1)$$

For example,

600 kHz requires 40 k Ω

150 kHz requires 160 k Ω

Synchronizing to an external clock at the SYNC pin in the same frequency range of 150 to 600 kHz is also possible. The device detects clock pulses at this pin, and an internal PLL locks on to the external clock within the specified range. The device also detects a loss of clock at this pin, and on detection of this condition, the device sets the switching frequency to the internal oscillator. The two buck controllers operate at identical switching frequencies, 180 degrees out-of-phase.

Enable Inputs

Independent enable inputs from the ENA and ENB pins enable the buck controllers. These are high-voltage pins, with a threshold of 1.7 V for the high level, and with which direct connection to the battery is permissible for self-bias. The low threshold is 0.7 V. These pins have internal pullup currents of 0.5 μA (typical). As a result, an open circuit on these pins enables the respective buck controllers. When both buck controllers are disabled, the device shuts down and consumes a current of less than 4 μA .

Feedback Inputs

The resistor-feedback divider network connected to the FBx (feedback) pins sets the output voltage. Choose this network such that the regulated voltage at the FBx pin equals 0.8 V. The FBx pins have a 100-nA pullup current source as a protection feature in case the pins open up as a result of physical damage.

Soft-Start Inputs

In order to avoid large inrush currents, each buck controller has an independent programmable soft-start timer. The voltage at the SSx pin acts as the soft-start reference voltage. The 1- μA pullup current available at the SSx pins, in combination with a suitably chosen capacitor, generates a ramp of the desired soft-start speed. After start-up, the pullup current ensures that SSx is higher than the internal reference of 0.8 V; 0.8 V then becomes the reference for the buck controllers. [Equation 2](#) calculates the soft-start ramp time:

$$C_{\text{SS}} = \frac{I_{\text{SS}} \times \Delta t}{\Delta V} \quad (\text{Farads})$$

where,

- $I_{\text{SS}} = 50 \mu\text{A}$ (typical)
 - $\Delta V = 0.8 \text{ V}$
 - C_{SS} is the required capacitor for Δt , the desired soft-start time
- (2)

An alternative use of the soft-start pins is as tracking inputs. In this case, connect them to the supply to be tracked via a suitable resistor-divider network.

Current-Mode Operation

Peak-current-mode control regulates the peak current through the inductor to maintain the output voltage at the set value. The error between the feedback voltage at FBx and the internal reference produces a signal at the output of the error amplifier (COMPx) which serves as the target for the peak inductor current. The device senses the current through the inductor as a differential voltage at Sx1–Sx2 and compares voltage with this target during each cycle. A fall or rise in load current produces a rise or fall in voltage at FBx, causing V_{COMPx} to fall or rise respectively, thus increasing or decreasing the current through the inductor until the average current matches the load. This process maintains the output voltage in regulation.

The top N-channel MOSFET turns on at the beginning of each clock cycle and stays on until the inductor current reaches the peak value. Once this MOSFET turns off, and after a small delay (shoot-through delay) the lower N-channel MOSFET turns on until the start of the next clock cycle. In dropout operation, the high-side MOSFET stays on continuously. In every fourth clock cycle, there is a limit on the duty cycle of 95% in order to charge the bootstrap capacitor at CBx, which allows a maximum duty cycle of 98.75% for the buck regulators. During dropout, the buck regulator switches at one-fourth of the normal frequency.

Current Sensing and Current Limit With Foldback

Clamping of the maximum value of COMPx limits the maximum current through the inductor to a specified value. When the output of the buck regulator (and hence the feedback value at FBx) falls to a low value due to a short circuit or overcurrent condition, the clamped voltage at COMPx successively decreases, thus providing current foldback protection, which protects the high-side external MOSFET from excess current (forward-direction current limit).

Similarly, if a fault condition shorts the output to a high voltage and the low-side MOSFET turns fully on, the COMPx node drops low. A clamp is on the lower end as well in order to limit the maximum current in the low-side MOSFET (reverse-direction current limit).

An external resistor senses the current through the inductor. Choose the sense resistor such that the maximum forward peak current in the inductor generates a voltage of 75 mV across the sense pins. This specified value is for low duty cycles only. At typical duty-cycle conditions around 40% (assuming 5 V output and 12 V input), 50 mV is a more reasonable value, considering tolerances and mismatches. The typical characteristics (see [Figure 19](#)) provide a guide for using the correct current-limit sense voltage.

The current-sense pins Sx1 and Sx2 are high-impedance pins with low leakage across the entire output range, thus allowing DCR current-sensing using the dc resistance of the inductor for higher efficiency. [Figure 20](#) shows DCR sensing. Here, the series resistance (DCR) of the inductor is the sense element. Place the filter components close to the device for noise immunity. Remember that while the DCR sensing gives high efficiency, it is inaccurate due to the temperature sensitivity and a wide variation of the parasitic inductor series resistance. Hence, using the more-accurate sense resistor for current sensing is advantageous.

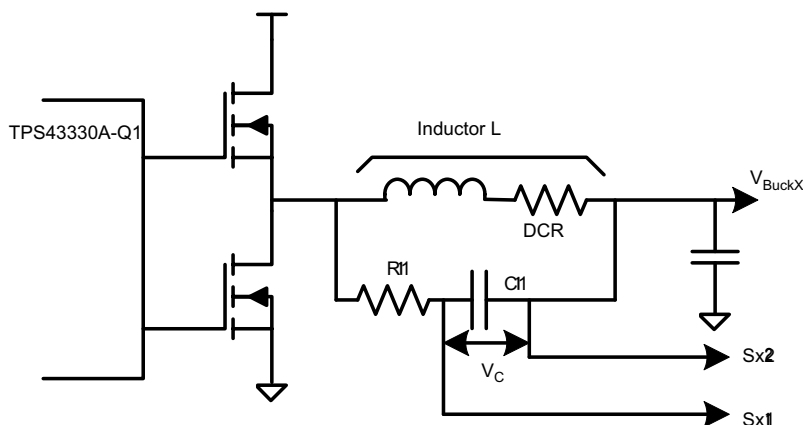

Figure 20. DCR Sensing Configuration

Slope Compensation

Optimal slope compensation, which is adaptive to changes in input voltage and duty cycle, allows stable operation under all conditions. For optimal performance of this circuit, choose the inductor and sense resistor according to the following:

$$\frac{L \times f_{sw}}{R_s} = 200$$

where

- L is the buck-regulator inductor in henries
 - R_s is the sense resistor in ohms
 - f_{sw} is the buck-regulator switching frequency in hertz
- (3)

Power-Good Outputs and Filter Delays

Each buck controller has an independent power-good comparator monitoring the feedback voltage at the FBx pins and indicating whether the output voltage falls below a specified power-good threshold. This threshold has a typical value of 93% of the regulated output voltage. The power-good indicator is available as an open-drain output at the PGx pins. Shutdown of a buck controller causes an internal pulldown of the power-good indicator. Connecting the pullup resistor to a rail other than the output of that particular buck channel causes a constant-current flow through the resistor when the buck controller is powered down.

In order to avoid triggering the power-good indicators due to noise or fast transients on the output voltage, the device uses an internal delay circuit for de-glitching. Similarly, when the output voltage returns to the set value after a long negative transient, assertion of the power-good indicator (release of the open-drain pin) occurs after the same delay. Use of this delay pauses the reset of circuits powered from the buck-regulator rail. Program the duration of the delay by using a suitable capacitor at the DLYAB pin according to [Equation 4](#).

$$\frac{t_{DELAY}}{C_{DLYAB}} = \frac{1 \text{ msec}}{1 \text{ nF}}$$
(4)

When the DLYAB pin is open, the delay setting is for a default value of 20 μ s typical. The power-good delay timing is common to both the buck rails, but the power-good comparators and indicators function independently.

Light-Load PFM Mode

An external clock or a high level on the SYNC pin results in forced continuous-mode operation of the bucks. An open or low on the SYNC pin allows the buck controllers to operate in discontinuous mode at light loads by turning off the low-side MOSFET on detection of a zero-crossing in the inductor current.

In discontinuous mode, as the load decreases, the duration when both the high-side and low-side MOSFETs turn off increases (deep-discontinuous mode). In case the duration exceeds 60% of the clock period and $V_{BAT} > 8 \text{ V}$, the buck controller switches to a low-power operation mode. The design ensures that this switching typically occurs at 1% of the set full-load current if the choice of the inductor and sense resistor is as recommended in the [Slope Compensation](#) section.

In low-power PFM mode, the buck monitors the FBx voltage and compares it with the 0.8-V internal reference. Whenever the FBx value falls below the reference, the high-side MOSFET turns on for a pulse duration inversely proportional to the difference $V_{IN} - Sx2$. At the end of this on-time, the high-side MOSFET turns off and the current in the inductor decays until the current becomes zero. The low-side MOSFET does not turn on. The next pulse occurs the next time FBx falls below the reference value. This pulsing results in a constant volt-second t_{on} hysteretic operation with a total device-quiescent current consumption of 30 μ A when a single-buck channel is active and of 35 μ A when both channels are active.

As the load increases, the pulses become more and more frequent and move closer to each other until the current in the inductor becomes continuous. At this point, the buck controller returns to normal fixed-frequency current-mode control. Another criterion to exit the low-power mode is when V_{IN} falls low enough to require higher than 80% duty cycle of the high-side MOSFET.

The TPS43330A-Q1 supports the full-current load during low-power mode until the transition to normal mode takes place. The design ensures that exit of the low-power mode occurs at 10% (typical) of full-load current if the selection of the inductor and sense resistor is as recommended. Moreover, a hysteresis always exists between the entry and exit thresholds to avoid oscillating between the two modes.

In the event that both buck controllers are active, low-power mode is only possible when both buck controllers have light loads that are low enough for low-power mode entry. With the boost controller enabled, low-power mode is possible only if V_{BAT} is high enough to prevent the boost from switching and if DIV is open or set to GND. A high (V_{REG}) level on DIV inhibits low-power mode, unless ENC is set to low.

Boost Controller

The boost controller has a fixed-frequency voltage-mode architecture and includes cycle-by-cycle current-limit protection for the external N-channel MOSFET. The boost-controller switching-frequency setting is one-half of the buck-controller switching frequency. An internal resistor-divider network programmable to 7 V, 8.85 V, or 10 V sets the output voltage of the boost controller at the VIN pin, based on the low, open, or high status, respectively, of the DIV pin. The device does not recognize a change of the DIV setting while in the low-power mode.

The active-high ENC pin enables the boost controller, which is active when the input voltage at the VBAT pin has crossed the unlock threshold of 8.5 V at least once. A single threshold crossing arms with the boost controller, which starts switching as soon as V_{IN} falls below the value set by the DIV pin, regulating the VIN voltage. Thus, the boost regulator maintains a stable input voltage for the buck regulators during transient events such as a cranking pulse at VBAT.

A voltage at the DS pin exceeding 200 mV pulls the CG1 pin low, turning off the boost external MOSFET. Connecting the DS pin to the drain of the MOSFET or to a sense resistor between the MOSFET source and ground achieves cycle-by-cycle overcurrent protection for the MOSFET. Choose the on-resistance of the MOSFET or the value of the sense resistor in such a way that the on-state voltage at DS does not exceed 200 mV at the maximum-load and minimum-input-voltage conditions. When using a sense resistor, TI recommends connecting a filter network between the DS pin and the sense resistor for better noise immunity.

The boost output (VIN) supplies other circuits in the system, however, they should be high-voltage tolerant. The device regulates the boost output to the programmed value only when VIN is low, and so VIN reaches battery levels.

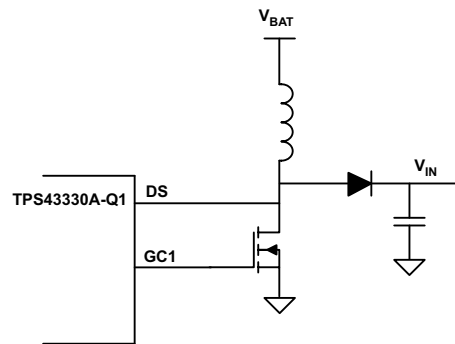

Figure 21. External Drain-Source Voltage Sensing

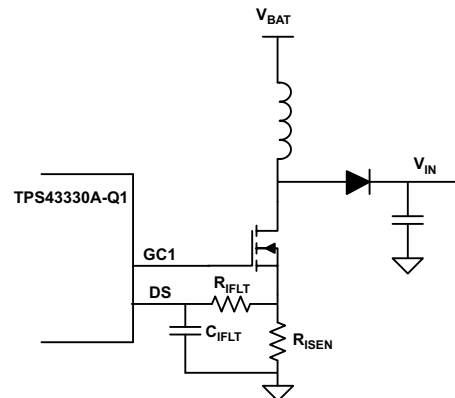

Figure 22. External Current Shunt Resistor

Table 1. Mode Control

SYNC Terminal	Comments
External clock	Device in forced-continuous mode, internal PLL locks into external clock between 150 and 600 kHz.
Low or open	Device enters discontinuous mode. Automatic LPM entry and exit, depending on load conditions
High	Device in forced continuous mode

Table 2. Mode of Operation

ENABLE AND INHIBIT PINS				DRIVER STATUS		DEVICE STATUS	QUIESCENT CURRENT
ENA	ENB	ENC	SYNC	BUCK CONTROLLERS	BOOST CONTROLLER		
Low	Low	Low	X	Shut down	Disabled	Shutdown	Approximately 4 μ A
Low	High	Low	Low	BuckB running	Disabled	BuckB: LPM enabled	Approximately 30 μ A (light loads)
			High			BuckB: LPM inhibited	mA range
High	Low	Low	Low	BuckA running	Disabled	BuckA: LPM enabled	Approximately 30 μ A (light loads)
			High			BuckA: LPM inhibited	mA range
High	High	Low	Low	BuckA and BuckB running	Disabled	BuckA and BuckB: LPM enabled	Approximately 35 μ A (light loads)
			High			BuckA and BuckB: LPM inhibited	mA range
Low	Low	Low	X	Shut down	Disabled	Shutdown	Approximately 4 μ A
Low	High	High	Low	BuckB running	Boost running for $V_{IN} <$ set boost output	BuckB: LPM enabled	Approximately 50 μ A (no boost, light loads)
			High			BuckB: LPM inhibited	mA range
High	Low	High	Low	BuckA running	Boost running for $V_{IN} <$ set boost output	BuckA: LPM enabled	Approximately 50 μ A (no boost, light loads)
			High			BuckA: LPM inhibited	mA range
High	High	High	Low	BuckA and BuckB running	Boost running for $V_{IN} <$ set boost output	BuckA and BuckB: LPM enabled	Approximately 60 μ A (no boost, light loads)
			High			BuckA and BuckB: LPM inhibited	mA range

Gate-Driver Supply (VREG, EXTSUP)

The gate-driver supplies of the buck and boost controllers are from an internal linear regulator whose output (5.8 V typical) is on the VREG pin and requires decoupling with a ceramic capacitor in the range of 3.3 to 10 μF . This pin has internal current-limit protection; do not use it to power any other circuits.

VIN powers the VREG linear regulator by default when the EXTSUP voltage is lower than 4.6 V (typical). If there is an expectation of V_{IN} going to high levels, an excessive power dissipation occurs in this regulator, especially at high switching frequencies and when using large external MOSFETs. In this case, powering this regulator from the EXTSUP pin, which has a connection to a supply lower than V_{IN} but high enough to provide the gate drive, is advantageous. When the voltage on EXTSUP is greater than 4.6 V, the linear regulator automatically switches to EXTSUP as its input, to provide this advantage. Efficiency improvements are possible when using one of the switching regulator rails from the TPS43330A-Q1 or any other voltage available in the system to power EXTSUP. The maximum voltage for application to EXTSUP is 9 V.

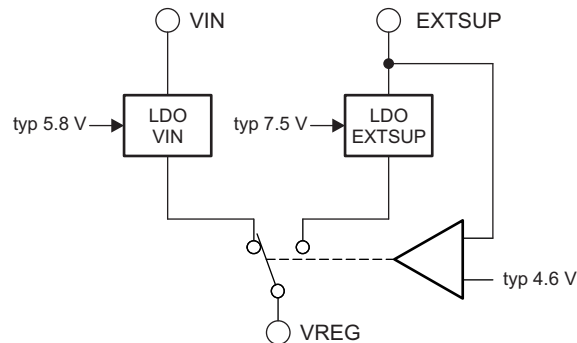

Figure 23. Internal Gate-Driver Supply

Using a voltage above 5.8 V (sourced by VIN) for EXTSUP is advantageous, as this voltage provides a large gate drive and hence better on-resistance of the external MOSFETs.

During low-power mode, the EXTSUP functionality is unavailable. The internal regulator operates as a shunt regulator powered from VIN and has a typical value of 7.5 V. Current-limit protection for VREG is available in low-power mode as well. If EXTSUP is unused, leave the pin open without a capacitor installed.

External P-Channel Drive (GC2) and Reverse-Battery Protection

The TPS43330A-Q1 includes a gate driver for an external P-channel MOSFET which connects across the rectifier diode of the boost regulator. Such connection is useful to reduce power losses when the boost controller is not switching. The gate driver provides a swing of 6 V typical below the VIN voltage in order to drive a P-channel MOSFET. When V_{BAT} falls below the boost-enable threshold, the gate driver turns off the P-channel MOSFET, eliminating the diode bypass.

Another use for the gate driver is to bypass any additional protection diodes connected in series, as shown in [Figure 24](#). [Figure 25](#) also shows a different scheme of reverse battery protection, which may require only a smaller-sized diode to protect the N-channel MOSFET, as the diode conducts only for a part of the switching cycle. Because the diode is not always in the series path, the system efficiency improves.

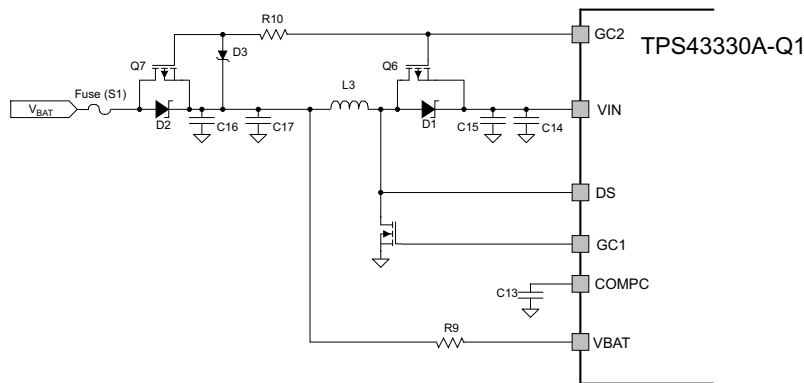

Figure 24. Reverse-Battery Protection Option 1 for Buck-Boost Configuration

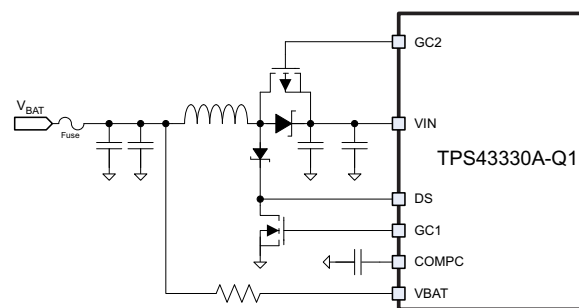

Figure 25. Reverse-Battery Protection Option 2 for Buck-Boost Configuration

Undervoltage Lockout and Overvoltage Protection

The TPS43330A-Q1 starts up at a V_{IN} voltage of 6.5 V (minimum), required for the internal supply (V_{REG}). Once the device starts up, it operates down to a V_{IN} voltage of 3.6 V; below this voltage level, the undervoltage lockout disables the device.

NOTE

If V_{IN} drops, V_{REG} drops as well which reduces the gate-drive voltage, whereas the digital logic is fully functional. Even if ENC is high, there is a requirement to exceed the boost-unlock voltage of typically 8.5 V once, before boost activation takes place (see the [Boost Controller](#) section).

A voltage of 46 V at V_{IN} triggers the overvoltage comparator, which shuts down the device. In order to prevent transient spikes from shutting down the device, the undervoltage and overvoltage protection have filter times of 5 μ s (typical).

When the voltages return to the normal-operating region, the enabled switching regulators start including a new soft-start ramp for the buck regulators.

With the boost controller enabled, a voltage less than 1.9 V (typical) on V_{BAT} triggers an undervoltage lockout and pulls the boost-gate driver (GC1) low (this action has a filter delay of 5 μ s, typical). As a result, V_{IN} falls at a rate dependent on the capacitor and load, eventually triggering V_{IN} undervoltage. A short-falling transient at V_{BAT} even lower than 2 V thus survives if V_{BAT} returns above 2.5 V before V_{IN} discharges to the undervoltage threshold.

Thermal Protection

The TPS43330A-Q1 protects from overheating using an internal thermal-shutdown circuit. If the die temperature exceeds the thermal-shutdown threshold of 165°C due to excessive power dissipation (for example, due to fault conditions such as a short circuit at the gate drivers or VREG), the controllers turn off and then restart when the temperature falls by 15°C.

APPLICATION INFORMATION

The following example illustrates the design process and component selection for the TPS43330A-Q1. Table 3 lists the design-goal parameters.

Table 3. Application Example

PARAMETER	V _{BuckA}	V _{BuckB}	BOOST
Input voltage	V _{IN} = 6 V to 30 V 12 V - typical	V _{IN} = 6 V to 30 V 12 V - typical	V _{BAT} = 5 V (cranking pulse input) to 30 V
Output voltage, V _{OUTx}	5 V	3.3 V	10 V
Maximum output current, I _{OUTx}	3 A	2 A	2.5 A
Load-step output tolerance, ΔV _{OUT} + ΔV _{OUT(Ripple)}	±0.2 V	±0.12 V	±0.5 V
Current output load-step, ΔI _{OUTx}	0.1 to 3 A	0.1 to 2 A	0.1 to 2.5 A
Converter switching frequency, f _{SW}	400 kHz	400 kHz	200 kHz

This example is a starting point and theoretical representation of the values for use in the application; improving the performance of the device may require further optimization of the derived components.

Boost Component Selection

A boost converter operating in continuous-conduction mode (CCM) has a right-half-plane (RHP) zero in its transfer function. The RHP zero relates inversely to the load current and inductor value and directly to the input voltage. The RHP zero limits the maximum bandwidth achievable for the boost regulator. If the bandwidth is too close to the RHP zero frequency, the regulator becomes unstable.

Thus, for high-power systems with low input voltages, choose a low inductor value. A low value increases the amplitude of the ripple currents in the N-channel MOSFET, the inductor, and the capacitors for the boost regulator. Select these components with the ripple-to-RHP zero trade-off in mind and considering the power dissipation effects in the components due to parasitic series resistance.

A boost converter that operates always in the discontinuous mode does not contain the RHP zero in the transfer function. However, designing for the discontinuous mode demands an even lower inductor value that has high ripple currents. Also, ensure that the regulator never enters the continuous-conduction mode; otherwise, it becomes unstable.

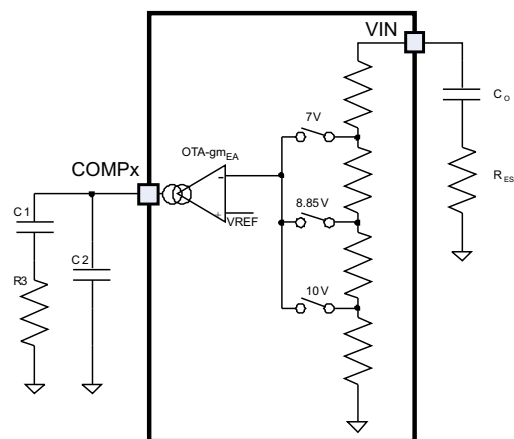

Figure 26. Boost Compensation Components

This design assumes operation in continuous-conduction mode. During light-load conditions, the boost converter operates in discontinuous mode without affecting stability. Hence, the assumptions here cover the worst case for stability.

Boost Maximum Input Current I_{IN_MAX}

The maximum input current flows at the minimum input voltage and maximum load. The efficiency for $V_{BAT} = 5\text{ V}$ at 2.5 A is 80%, based on the typical characteristics plot.

$$P_{INmax} = \frac{P_{OUT}}{\text{Efficiency}} = \frac{25\text{ W}}{0.8} = 31.3\text{ W} \quad (5)$$

Hence,

$$I_{INmax}(\text{at } V_{BAT} = 5\text{ V}) = \frac{31.3\text{ W}}{5\text{ V}} = 6.3\text{ A} \quad (6)$$

Boost Inductor Selection, L

Allow input ripple current of 40% of I_{IN_max} at $V_{BAT} = 5\text{ V}$.

$$L = \frac{V_{BAT} \times t_{ON}}{I_{IRipplemax}} = \frac{V_{BAT}}{I_{IRipplemax} \times 2 \times f_{SW}} = \frac{5\text{ V}}{2.52\text{ A} \times 2 \times 200\text{ kHz}} = 4.9\text{ }\mu\text{H} \quad (7)$$

Choose a lower value of 4 μH in order to ensure a high RHP-zero frequency while making a compromise that expects a high current ripple. This inductor selection also makes the boost converter operate in discontinuous conduction mode, where it is easier to compensate.

The inductor-saturation current must be higher than the peak-inductor current and some percentage higher than the maximum current-limit value set by the external resistive-sensing element.

Determine the saturation rating at the minimum input voltage, maximum output current, and maximum core temperature for the application.

Inductor Ripple Current, I_{RIPPLE}

Based on an inductor value of 4 μH , the ripple current is approximately 3.1 A.

Peak Current in Low-Side FET, I_{PEAK}

$$I_{PEAK} = I_{INmax} + \frac{I_{RIPPLE}}{2} = 6.3\text{ A} + \frac{3.1\text{ A}}{2} = 7.85\text{ A} \quad (8)$$

Based on this peak current value, calculate the external current-sense resistor R_{SENSE} .

$$R_{SENSE} = \frac{0.2\text{ V}}{7.85\text{ A}} = 25\text{ m}\Omega \quad (9)$$

Select 20 $\text{m}\Omega$, allowing for tolerance.

The filter component values R_{IFLT} and C_{IFLT} for current sense are 1.5 $\text{k}\Omega$ and 1 nF, respectively, which allows for good noise immunity.

Right Half-Plane Zero RHP Frequency, f_{RHP}

$$f_{RHP} = \frac{V_{BATmin}}{2\pi \times I_{INmax} \times L} = 32\text{ kHz} \quad (10)$$

Output Capacitor, C_{OUTx}

To ensure stability, choose output capacitor C_{OUTx} such that

$$f_{LC} \leq \frac{f_{RHP}}{10}$$

$$\frac{10}{2\pi \times \sqrt{L \times C_{OUTx}}} \leq \frac{V_{BATmin}}{2\pi \times I_{INmax} \times L}$$

$$C_{OUTx} \geq \left(\frac{10 \times I_{INmax}}{V_{BATmin}} \right)^2 \times L = \left(\frac{10 \times 6.3 \text{ A}}{5 \text{ V}} \right)^2 \times 4 \mu\text{H}$$

$$C_{OUTx \text{ min}} \geq 635 \mu\text{F} \tag{11}$$

Select $C_{OUTx} = 680 \mu\text{F}$.

This capacitor is usually aluminum electrolytic with ESR in the tens-of-milliohms. ESR in this range is good for loop stability, because it provides a phase boost. The output filter components, L and C, create a double pole (180-degree phase shift) at a frequency f_{LC} and the ESR of the output capacitor R_{ESR} creates a zero for the modulator at frequency f_{ESR} . One can determine these frequencies by [Equation 12](#).

$$f_{ESR} = \frac{1}{2\pi \times C_{OUTx} \times R_{ESR}} \text{ Hz, assume } R_{ESR} = 40 \text{ m}\Omega$$

$$f_{ESR} = \frac{1}{2\pi \times 660 \mu\text{F} \times 0.04 \Omega} = 6 \text{ kHz}$$

$$f_{LC} = \frac{1}{2\pi \times \sqrt{L \times C_{OUTx}}} = \frac{1}{2\pi \times \sqrt{4 \mu\text{H} \times 660 \mu\text{F}}} = 3.1 \text{ kHz} \tag{12}$$

This satisfies $f_{LC} \leq 0.1 f_{RHP}$.

Bandwidth of Boost Converter, f_c

Use the following guidelines to set the frequency poles, zeroes, and crossover values for the trade-off between stability and transient response:

$$f_{LC} < f_{ESR} < f_c < f_{RHP \text{ Zero}}$$

$$f_c < f_{RHP \text{ Zero}} / 3$$

$$f_c < f_{SW} / 6$$

$$f_{LC} < f_c / 3$$

Output Ripple Voltage Due to Load Transients, ΔV_{OUTx}

Assume a bandwidth of $f_C = 10$ kHz.

$$\begin{aligned}\Delta V_{OUTx} &= R_{ESR} \times \Delta I_{OUTx} + \frac{\Delta I_{OUTx}}{4 \times C_{OUTx} \times f_C} \\ &= 0.04 \Omega \times 2.5 \text{ A} + \frac{2.5 \text{ A}}{4 \times 660 \mu\text{F} \times 10 \text{ kHz}} = 0.19 \text{ V}\end{aligned}\quad (13)$$

Because the boost converter is active only during brief events such as a cranking pulse, and the buck converters are high-voltage tolerant, a higher excursion on the boost output is tolerable in some cases. In such cases, choose smaller components for the boost output.

Selection of Components for Type II Compensation

The required loop gain for unity-gain bandwidth (UGB) is

$$\begin{aligned}G &= 40 \log\left(\frac{f_C}{f_{LC}}\right) - 20 \log\left(\frac{f_C}{f_{ESR}}\right) \\ G &= 40 \log\left(\frac{10 \text{ kHz}}{3.1 \text{ kHz}}\right) - 20 \log\left(\frac{10 \text{ kHz}}{6 \text{ kHz}}\right) = 15.9 \text{ dB}\end{aligned}\quad (14)$$

The boost-converter error amplifier (OTA) has a G_m that is proportional to the VBAT voltage, which allows a constant loop response across the input-voltage range and makes compensation easier by removing the dependency on V_{BAT} .

$$\begin{aligned}R3 &= \frac{10^{G/20}}{85 \times 10^{-6} \text{ A} / \text{V}^2 \times V_{OUTx}} = 7.2 \text{ k}\Omega \\ C1 &= \frac{10}{2\pi \times f_C \times R3} = \frac{10}{2\pi \times 10 \text{ kHz} \times 7.2 \text{ k}\Omega} = 22 \text{ nF} \\ C2 &= \frac{C1}{2\pi \times R3 \times C1 \times \left(\frac{f_{SW}}{2}\right) - 1} = \frac{22 \text{ nF}}{2\pi \times 7.2 \text{ k}\Omega \times 22 \text{ nF} \times \left(\frac{200 \text{ kHz}}{2}\right) - 1} = 223 \text{ pF}\end{aligned}\quad (15)$$

Input Capacitor, C_{IN}

The input ripple required is lower than 50 mV.

$$\begin{aligned}\Delta V_{C1} &= \frac{I_{RIPPLE}}{8 \times f_{SW} \times C_{IN}} = 10 \text{ mV} \\ C_{IN} &= \frac{I_{RIPPLE}}{8 \times f_{SW} \times \Delta V_{C1}} = 194 \mu\text{F} \\ \Delta V_{ESR} &= I_{RIPPLE} \times R_{ESR} = 40 \text{ mV}\end{aligned}\quad (16)$$

Therefore, TI recommends 220 μF with 10-m Ω ESR.

Output Schottky Diode D1 Selection

Maximizing efficiency requires a Schottky diode with low forward-conducting voltage V_F over temperature and fast switching characteristics. The reverse breakdown voltage must be higher than the maximum input voltage, and the component must have low reverse leakage current. Additionally, the peak forward current must be higher than the peak inductor current. Equation 17 gives the power dissipation in the Schottky diode:

$$P_D = I_{D(\text{PEAK})} \times V_F \times (1 - D)$$

$$D = 1 - \frac{V_{\text{INMIN}}}{V_{\text{OUT}} + V_F} = 1 - \frac{5 \text{ V}}{10 \text{ V} + 0.6 \text{ V}} = 0.53$$

$$P_D = 7.85 \text{ A} \times 0.6 \text{ V} \times (1 - 0.53) = 2.2 \text{ W} \quad (17)$$

Low-Side MOSFET (BOT_SW3)

$$P_{\text{BOOSTFET}} = (I_{\text{PK}})^2 \times r_{\text{DS(on)}}(1 + \text{TC}) \times D + \left(\frac{V_I \times I_{\text{PK}}}{2} \right) \times (t_r + t_f) \times f_{\text{SW}}$$

$$P_{\text{BOOSTFET}} = (7.85 \text{ A})^2 \times 0.02 \Omega \times (1 + 0.4) \times 0.53 + \left(\frac{V_I \times I_{\text{PK}}}{2} \right) \times (20 \text{ ns} + 20 \text{ ns}) \times 200 \text{ kHz} = 1.07 \text{ W} \quad (18)$$

The times t_r and t_f denote the rising and falling times of the switching node and relate to the gate-driver strength of the TPS43330A-Q1 and gate Miller capacitance of the MOSFET. The first term, t_r , denotes the conduction losses, which the low on-resistance of the MOSFET minimizes. The second term, t_f , denotes the transition losses which arise due to the full application of the input voltage across the drain-source of the MOSFET as it turns on or off. Transition losses are higher at high output currents and low input voltages (due to the large input peak current), and when the switching time is low.

NOTE

The on-resistance, $r_{\text{DS(on)}}$, has a positive temperature coefficient, which produces the $(\text{TC} = d \times \Delta T)$ term that signifies the temperature dependence. (Temperature coefficient d is available as a normalized value from MOSFET data sheets and has an assumed starting value of 0.005 per °C.)

BuckA Component Selection

BuckA Component Selection

$$t_{\text{ON min}} = \frac{V_{\text{OUTA}}}{V_{\text{IN max}} \times f_{\text{SW}}} = \frac{3.3 \text{ V}}{30 \text{ V} \times 400 \text{ kHz}} = 275 \text{ ns} \quad (19)$$

$t_{\text{ON min}}$ is higher than the minimum duty cycle specified (100 ns typical). Hence, the minimum duty cycle is achievable at this frequency.

Current-Sense Resistor R_{SENSE}

Based on the typical characteristics for the V_{SENSE} limit with V_{IN} versus duty cycle, the sense limit is approximately 65 mV (at $V_{IN} = 12$ V and duty cycle of 5 V / 12 V = 0.416). Allowing for tolerances and ripple currents, choose a V_{SENSE} maximum of 50 mV.

$$R_{SENSE} = \frac{50 \text{ mV}}{3 \text{ A}} = 17 \text{ m}\Omega \quad (20)$$

Select 15 m Ω .

Inductor Selection L

As explained in the description of the buck controllers (see [DETAILED DESCRIPTION](#)), for optimal slope compensation and loop response, choose the inductor such that:

$$L = K_{FLR} \times \frac{R_{SENSE}}{f_{SW}} = 200 \times \frac{15 \text{ m}\Omega}{400 \text{ kHz}} = 7.5 \text{ }\mu\text{H}$$

- K_{FLR} = coil-selection constant = 200 (21)

Choose a standard value of 8.2 μ H. For the buck converter, choose the inductor saturation currents and core to sustain the maximum currents.

Inductor Ripple Current I_{RIPPLE}

At the nominal input voltage of 12 V, this inductor value causes a ripple current of 30% of $I_{OUT \text{ max}} \approx 1$ A.

Output Capacitor C_{OUTA}

Select an output capacitance C_{OUTA} of 100 μ F with low ESR in the range of 10 m Ω , giving $\Delta V_{OUT(Ripple)} \approx 15$ mV and a ΔV drop of ≈ 180 mV during a load step, which does not trigger the power-good comparator and is within the required limits.

$$C_{OUTA} \approx \frac{2 \times \Delta I_{OUTA}}{f_{SW} \times \Delta V_{OUTA}} = \frac{2 \times 2.9 \text{ A}}{400 \text{ kHz} \times 0.2 \text{ V}} = 72.5 \text{ }\mu\text{F} \quad (22)$$

$$V_{OUTA(Ripple)} = \frac{I_{OUTA(Ripple)}}{8 \times f_{SW} \times C_{OUTA}} + I_{OUTA(Ripple)} \times ESR = \frac{1 \text{ A}}{8 \times 400 \text{ kHz} \times 100 \text{ }\mu\text{F}} + 1 \text{ A} \times 10 \text{ m}\Omega = 13.1 \text{ mV} \quad (23)$$

$$\Delta V_{OUTA} = \frac{\Delta I_{OUTA}}{4 \times f_C \times C_{OUTA}} + \Delta I_{OUTA} \times ESR = \frac{2.9 \text{ A}}{4 \times 50 \text{ kHz} \times 100 \text{ }\mu\text{F}} + 2.9 \text{ A} \times 10 \text{ m}\Omega = 174 \text{ mV} \quad (24)$$

Bandwidth of Buck Converter f_C

Use the following guidelines to set frequency poles, zeroes, and crossover values for the trade-off between stability and transient response.

- Crossover frequency f_C between $f_{SW} / 6$ and $f_{SW} / 10$. Assume $f_C = 50$ kHz.
- Select the zero $f_z \approx f_C / 10$
- Make the second pole $f_{P2} \approx f_{SW} / 2$

Selection of Components for Type II Compensation

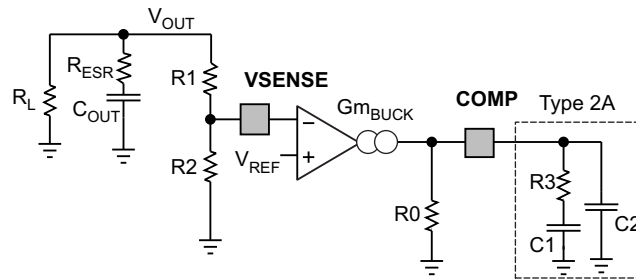

Figure 27. Buck Compensation Components

$$R3 = \frac{2\pi \times f_C \times V_{OUT} \times C_{OUTx}}{Gm_{BUCK} \times K_{CFB} \times V_{REF}} = \frac{2\pi \times 50 \text{ kHz} \times 5 \text{ V} \times 100\mu\text{F}}{Gm_{BUCK} \times K_{CFB} \times V_{REF}} = 23.57 \text{ k}\Omega$$

where

- $V_{OUT} = 5 \text{ V}$
- $C_{OUT} = 100 \mu\text{F}$
- $Gm_{BUCK} = 1 \text{ mS}$
- $V_{REF} = 0.8 \text{ V}$
- $K_{CFB} = 0.125 / R_{SENSE} = 8.33 \text{ S}$ (0.125 is an internal constant) (25)

Use the standard value of $R3 = 24 \text{ k}\Omega$.

$$C1 = \frac{10}{2\pi \times R3 \times f_C} = \frac{10}{2\pi \times 24 \text{ k}\Omega \times 50 \text{ kHz}} = 1.33 \text{ nF} \quad (26)$$

Use the standard value of 1.5 nF .

$$C2 = \frac{C1}{2\pi \times R3 \times C1 \left(\frac{f_{SW}}{2} \right) - 1} = \frac{1.5 \text{ nF}}{2\pi \times 24 \text{ k}\Omega \times 1.5 \text{ nF} \left(\frac{400 \text{ kHz}}{2} \right) - 1} = 33 \text{ pF} \quad (27)$$

The resulting bandwidth of buck converter f_C

$$f_C = \frac{Gm_{BUCK} \times R3 \times K_{CFB}}{2\pi \times C_{OUTx}} \times \frac{V_{REF}}{V_{OUT}}$$

$$f_C = \frac{1 \text{ mS} \times 24 \text{ k}\Omega \times 8.33 \text{ S} \times 0.8 \text{ V}}{2\pi \times 100 \mu\text{F} \times 5 \text{ V}} = 50.9 \text{ kHz} \quad (28)$$

f_C is close to the target bandwidth of 50 kHz .

The resulting zero frequency f_{z1}

$$f_{z1} = \frac{1}{2\pi \times R3 \times C1} = \frac{1}{2\pi \times 24 \text{ k}\Omega \times 1.5 \text{ nF}} = 4.42 \text{ kHz} \quad (29)$$

f_{z1} is close to the $f_C / 10$ guideline of 5 kHz .

The second pole frequency f_{p2}

$$f_{p2} = \frac{1}{2\pi \times R3 \times C2} = \frac{1}{2\pi \times 24 \text{ k}\Omega \times 33 \text{ pF}} = 201 \text{ kHz} \quad (30)$$

f_{p2} is close to the $f_{SW} / 2$ guideline of 200 kHz . Hence, the design satisfies all requirements for a good loop.

Resistor Divider Selection for Setting V_{OUTA} Voltage

$$\beta = \frac{V_{REF}}{V_{OUTA}} = \frac{0.8 \text{ V}}{5 \text{ V}} = 0.16 \quad (31)$$

Choose the divider current through R1 and R2 to be 50 μA . Then

$$R1 + R2 = \frac{5 \text{ V}}{50 \mu\text{A}} = 66 \text{ k}\Omega \quad (32)$$

and

$$\frac{R2}{R1 + R2} = 0.16 \quad (33)$$

Therefore, $R2 = 16 \text{ k}\Omega$ and $R1 = 84 \text{ k}\Omega$.

BuckB Component Selection

Using the same method as for V_{BUCKA} produces the following parameters and components.

$$t_{ON\min} = \frac{V_{OUTB}}{V_{IN\max} \times f_{SW}} = \frac{3.3 \text{ V}}{30 \text{ V} \times 400 \text{ kHz}} = 275 \text{ ns} \quad (34)$$

This result is higher than the minimum duty cycle specified (100 ns typical).

$$R_{SENSE} = \frac{60 \text{ mV}}{2 \text{ A}} = 30 \text{ m}\Omega$$

$$L = 200 \times \frac{30 \text{ m}\Omega}{400 \text{ kHz}} = 15 \mu\text{H} \quad (35)$$

ΔI_{ripple} current $\approx 0.4 \text{ A}$ (approximately 20% of $I_{OUT\max}$)

Select an output capacitance C_{OUTB} of 100 μF with low ESR in the range of 10 $\text{m}\Omega$.

Assume $f_C = 50 \text{ kHz}$.

$$C_{OUTB} \approx \frac{2 \times \Delta I_{OUTB}}{f_{SW} \times \Delta V_{OUTB}} = \frac{2 \times 1.9 \text{ A}}{400 \text{ kHz} \times 0.12 \text{ V}} = 46 \mu\text{F} \quad (36)$$

$$V_{OUTB(\text{Ripple})} = \frac{I_{OUTB(\text{Ripple})}}{8 \times f_{SW} \times C_{OUTB}} + I_{OUTB(\text{Ripple})} \times \text{ESR} = \frac{0.4 \text{ A}}{8 \times 400 \text{ kHz} \times 100 \mu\text{F}} + 0.4 \text{ A} \times 10 \text{ m}\Omega = 5.3 \text{ mV} \quad (37)$$

$$\Delta V_{OUTB} = \frac{\Delta I_{OUTB}}{4 \times f_C \times C_{OUTB}} + \Delta I_{OUTB} \times \text{ESR} = \frac{1.9 \text{ A}}{4 \times 50 \text{ kHz} \times 100 \mu\text{F}} + 1.9 \text{ A} \times 10 \text{ m}\Omega = 114 \text{ mV} \quad (38)$$

$$R3 = \frac{2\pi \times f_C \times V_{OUTB} \times C_{OUTB}}{G_{m\text{BUCK}} \times K_{\text{CFB}} \times V_{REF}} \\ = \frac{2\pi \times 50 \text{ kHz} \times 3.3 \text{ V} \times 100 \mu\text{F}}{1 \text{ mS} \times 4.16 \text{ S} \times 0.8 \text{ V}} = 31 \text{ k}\Omega \quad (39)$$

Use the standard value of $R3 = 30 \text{ k}\Omega$.

$$C1 = \frac{10}{2\pi \times R3 \times f_C} = \frac{10}{2\pi \times 30 \text{ k}\Omega \times 50 \text{ kHz}} = 1.1 \text{ nF} \quad (40)$$

$$\begin{aligned}
 C2 &= \frac{C1}{2\pi \times R3 \times C1 \times \left(\frac{f_{SW}}{2}\right) - 1} \\
 &= \frac{1.1 \text{ nF}}{2\pi \times 30 \text{ k}\Omega \times 1.1 \text{ nF} \times \left(\frac{400 \text{ kHz}}{2}\right) - 1} = 27 \text{ pF}
 \end{aligned}
 \tag{41}$$

$$\begin{aligned}
 f_C &= \frac{Gm_{BUCK} \times R3 \times K_{CFB} \times V_{REF}}{2\pi \times C_{OUTB} \times V_{OUTB}} \\
 &= \frac{1 \text{ mS} \times 30 \text{ k}\Omega \times 4.16 \text{ S} \times 0.8 \text{ V}}{2\pi \times 100 \text{ }\mu\text{F} \times 3.3 \text{ V}} = 48 \text{ kHz}
 \end{aligned}
 \tag{42}$$

f_C is close to the target bandwidth of 50 kHz.

The resulting zero frequency f_{Z1}

$$f_{Z1} = \frac{1}{2\pi \times R3 \times C1} = \frac{1}{2\pi \times 30 \text{ k}\Omega \times 1.1 \text{ nF}} = 4.8 \text{ kHz}
 \tag{43}$$

f_{Z1} is close to the f_C guideline of 5 kHz.

The second pole frequency f_{P2}

$$f_{P2} = \frac{1}{2\pi \times R3 \times C2} = \frac{1}{2\pi \times 30 \text{ k}\Omega \times 27 \text{ pF}} = 196 \text{ kHz}
 \tag{44}$$

f_{P2} is close to the $f_{SW} / 2$ guideline of 200 kHz.

Hence, the design satisfies all requirements for a good loop.

Resistor Divider Selection for Setting V_{OUT} Voltage

$$\beta = \frac{V_{REF}}{V_{OUT}} = \frac{0.8 \text{ V}}{3.3 \text{ V}} = 0.242
 \tag{45}$$

Choose the divider current through R1 and R2 to be 50 μA . Then

$$R1 + R2 = \frac{3.3 \text{ V}}{50 \text{ }\mu\text{A}} = 66 \text{ k}\Omega
 \tag{46}$$

and

$$\frac{R2}{R1 + R2} = 0.242
 \tag{47}$$

Therefore, $R2 = 16 \text{ k}\Omega$ and $R1 = 50 \text{ k}\Omega$.

BuckX High-Side and Low-Side N-Channel MOSFETs

An internal supply, which is 5.8 V typical under normal-operating conditions, provides the gate-drive supply for these MOSFETs. The output is a totem pole, allowing full-voltage drive of V_{REG} to the gate with peak output current of 1.5 A. The reference for the high-side MOSFET is a floating node at the phase terminal (PHx), and the reference for the low-side MOSFET is the power-ground (PGNDx) terminal. For a particular application, select these MOSFETs with consideration for the following parameters: $r_{DS(on)}$, gate charge Qg, drain-to-source breakdown voltage BVDSS, maximum dc current IDC(max), and thermal resistance for the package.

The times t_r and t_f denote the rising and falling times of the switching node and have a relationship to the gate-driver strength of the TPS43330A-Q1 and to the gate Miller capacitance of the MOSFET. The first term, t_r , denotes the conduction losses, which are minimal when the on-resistance of the MOSFET is low. The second term, t_f , denotes the transition losses, which arise due to the full application of the input voltage across the drain-source of the MOSFET as it turns on or off. Transition losses are lower at low currents and when the switching time is low.

$$P_{\text{BuckTOPFET}} = (I_{\text{OUT}})^2 \times r_{\text{DS(on)}}(1 + \text{TC}) \times D + \left(\frac{V_{\text{IN}} \times I_{\text{OUT}}}{2} \right) \times (t_r + t_f) \times f_{\text{SW}} \quad (48)$$

$$P_{\text{BuckLOWEFET}} = (I_{\text{OUT}})^2 \times r_{\text{DS(on)}}(1 + \text{TC}) \times (1 - D) + V_F \times I_{\text{OUT}} \times (2 \times t_d) \times f_{\text{SW}} \quad (49)$$

In addition, during the dead time (t_d) when both the MOSFETs are off, the body diode of the low-side MOSFET conducts, increasing the losses. The second term in [Equation 49](#) denotes this dead time. Using external Schottky diodes in parallel with the low-side MOSFETs of the buck converters helps to reduce this loss.

NOTE

$r_{\text{DS(on)}}$ has a positive temperature coefficient, and the TC term for $r_{\text{DS(on)}}$ accounts for that fact. $\text{TC} = d \times \Delta T[^\circ\text{C}]$. The temperature coefficient d is available as a normalized value from MOSFET data sheets and has an assumed starting value of 0.005 per $^\circ\text{C}$.

Schematics

The following section summarizes the previously calculated example and gives schematic and component proposals.

Table 4. Application Example 1

PARAMETER	V _{BuckA}	V _{BuckB}	BOOST
Input voltage	V _{IN} = 6 V to 30 V 12 V - typical	V _{IN} = 6 V to 30 V 12 V - typical	V _{BAT} = 5 V (cranking pulse input) to 30 V
Output voltage, V _{OUTx}	5 V	3.3 V	10 V
Maximum output current, I _{OUTx}	3 A	2 A	2.5 A
Load-step output tolerance, ΔV _{OUT} + ΔV _{OUT} (Ripple)	±0.2 V	±0.12 V	±0.5 V
Current output load-step, ΔI _{OUTx}	0.1 to 3 A	0.1 to 2 A	0.1 to 2.5 A
Converter switching frequency, f _{SW}	400 kHz	400 kHz	200 kHz

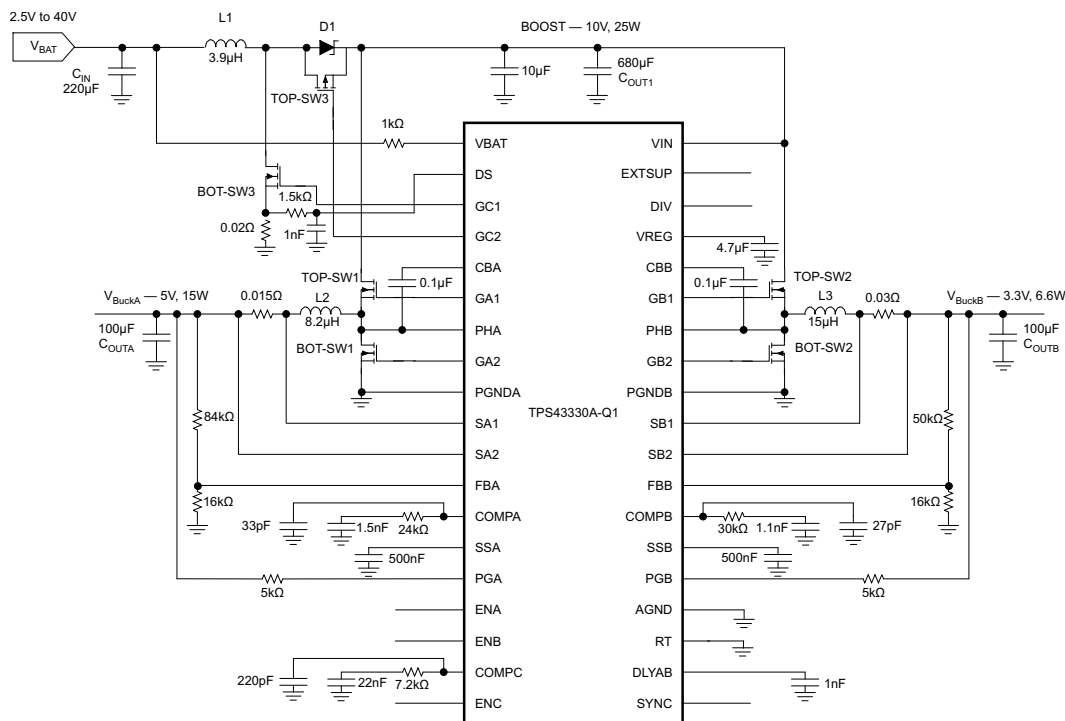

Figure 28. Simplified Application Schematic, Example 1

Table 5. Application Example 1 – Component Proposals

Name	Component Proposal	Value
L1	MSS1278T-392NL (Coilcraft)	4 µH
L2	MSS1278T-822ML (Coilcraft)	8.2 µH
L3	MSS1278T-153ML (Coilcraft)	15 µH
D1	SK103 (Micro Commercial Components)	
TOP_SW3	IRF7416 (International Rectifier)	
TOP_SW1, TOP_SW2	Si4840DY-T1-E3 (Vishay)	
BOT_SW1, BOT_SW2	Si4840DY-T1-E3 (Vishay)	
BOT_SW3	IRFR3504ZTRPBF (International Rectifier)	
C _{OUT1}	EEVFK1J681M (Panasonic)	680 µF
C _{OUTA} , C _{OUTB}	ECASD91A107M010K00 (Murata)	100 µF
C _{IN}	EEEFK1V331P (Panasonic)	220 µF

Table 6. Application Example 2

PARAMETER	V _{BuckA}	V _{BuckB}	BOOST
Input voltage	V _{IN} = 5 V to 30 V 12 V - typical	V _{IN} = 6 V to 30 V 12 V - typical	V _{BAT} = 5 V (cranking pulse input) to 30V
Output voltage, V _{OUTx}	5 V	3.3 V	10 V
Maximum output current, I _{OUTx}	2.7 A	5 A	3 A
Load-step output tolerance, ΔV _{OUT} + ΔV _{OUT} (Ripple)	±0.2 V	±0.12 V	±0.5 V
Current output load step, ΔI _{OUTx}	0.1 to 2.7 A	0.1 to 5 A	0.1 to 3 A
Converter switching frequency, f _{SW}	300 kHz	300 kHz	150 kHz

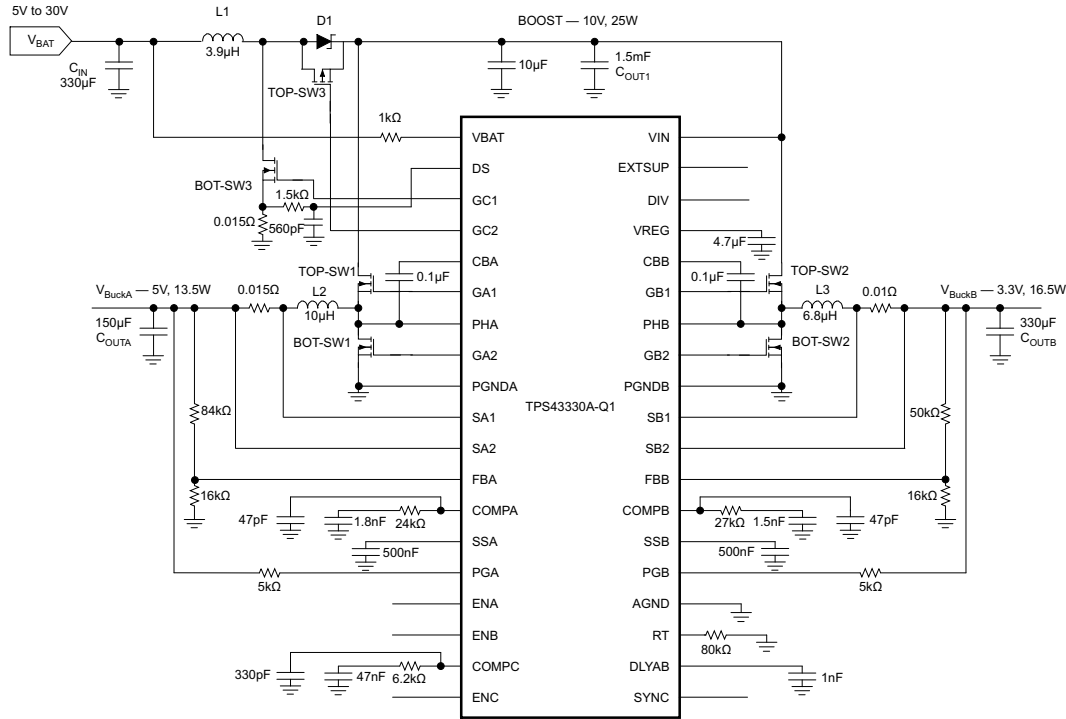

Figure 29. Simplified Application Schematic, Example 2

Table 7. Application Example 2 – Component Proposals

Name	Component Proposal	Value
L1	MSS1278T-392NL (Coilcraft)	3.9 µH
L2	MSS1278T-103ML (Coilcraft)	10 µH
L3	MSS1278T-682ML (Coilcraft)	6.8 µH
D1	SK103 (Micro Commercial Components)	
TOP_SW3	IRF7416 (International Rectifier)	
TOP_SW1, TOP_SW2	Si4840DY-T1-E3 (Vishay)	
BOT_SW1, BOT_SW2	Si4840DY-T1-E3 (Vishay)	
BOT_SW3	IRFR3504ZTRPBF (International Rectifier)	
C _{OUT1}	EEVFK1V152M (Panasonic)	1.5 mF
C _{OUTA}	ECASD91A157M010K00 (Murata)	150 µF
C _{OUTB}	ECASD90G337M008K00 (Murata)	330 µF
C _{IN}	EEEFK1V331P (Panasonic)	330 µF

Table 8. Application Example 3

PARAMETER	V _{BuckA}	V _{BuckB}	BOOST
Input voltage	V _{IN} = 5 V to 30 V 12 V - typical	V _{IN} = 6 V to 30 V 12 V - typical	V _{BAT} = 5 V (cranking pulse input) to 30 V
Output voltage, V _{OUTx}	5 V	2.5 V	10 V
Maximum output current, I _{OUTx}	3 A	1 A	2 A
Load-step output tolerance, ΔV _{OUT} + ΔV _{OUT} (Ripple)	±0.2 V	±0.12 V	±0.5 V
Current output load-step, ΔI _{OUTx}	0.1 to 3 A	0.1 to 1 A	0.1 to 2 A
Converter switching frequency, f _{SW}	400 kHz	400 kHz	200 kHz

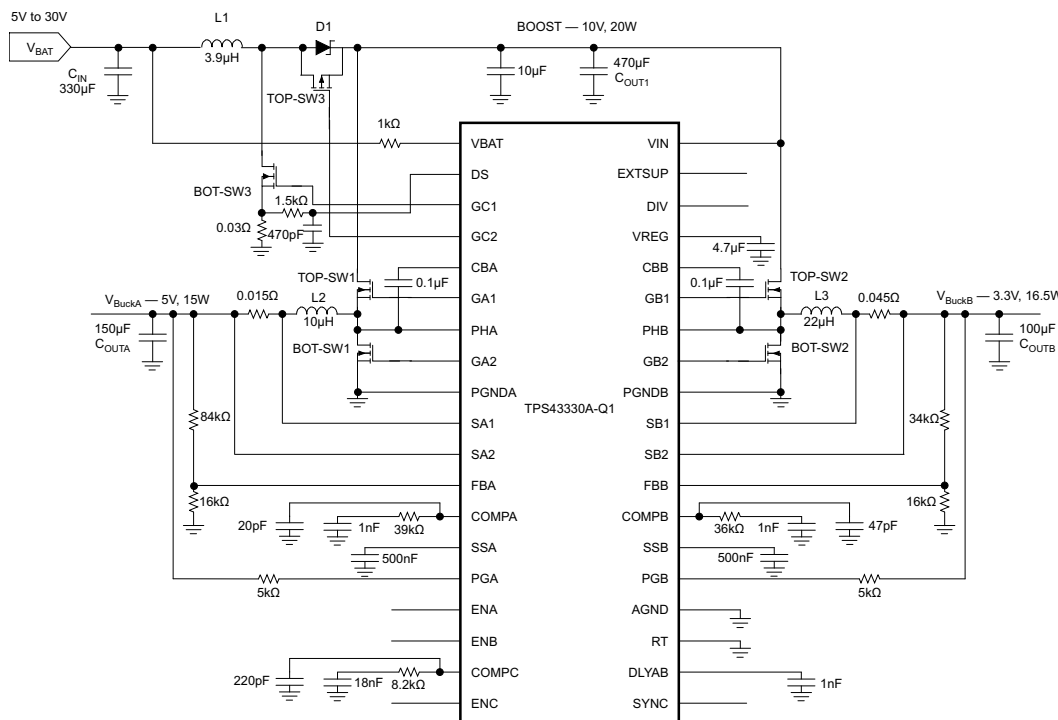

Figure 30. Simplified Application Schematic, Example 3

Table 9. Application Example 3 – Component Proposals

Name	Component Proposal	Value
L1	MSS1278T-392NL (Coilcraft)	3.9 μH
L2	MSS1278T-822ML (Coilcraft)	8.2 μH
L3	MSS1278T-223ML (Coilcraft)	22 μH
D1	SK103 (Micro Commercial Components)	
TOP_SW3	IRF7416 (International Rectifier)	
TOP_SW1, TOP_SW2	Si4840DY-T1-E3 (Vishay)	
BOT_SW1, BOT_SW2	Si4840DY-T1-E3 (Vishay)	
BOT_SW3	IRFR3504ZTRPBF (International Rectifier)	
C _{OUT1}	EEVFK1V471Q (Panasonic)	470 μF
C _{OUTA}	ECASD91A157M010K00 (Murata)	150 μF
C _{OUTB}	ECASD40J107M015K00 (Murata)	100 μF
C _{IN}	EEEFK1V331P (Panasonic)	330 μF

Power Dissipation Derating Profile, 38-Pin HTTSOP PowerPAD™ Package

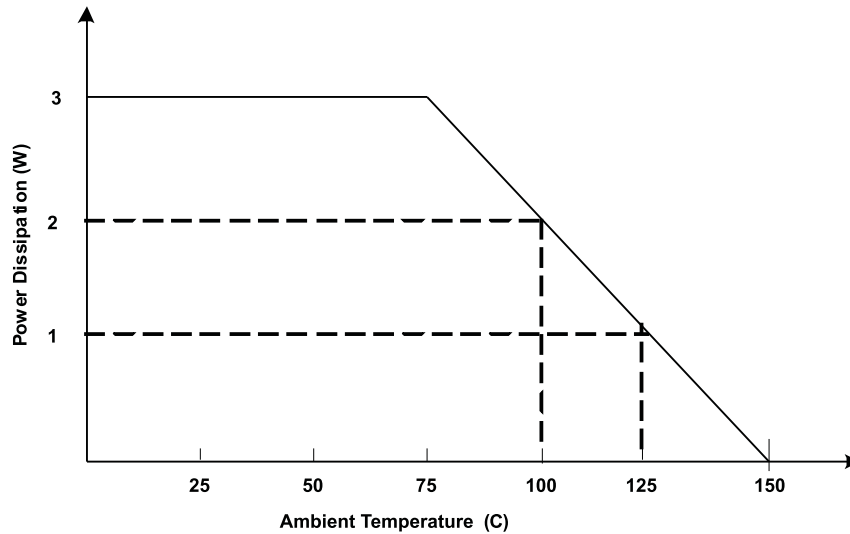

Figure 31. Derating Profile for Power Dissipation Based on High-K JEDEC PCB

PCB Layout Guidelines

Grounding and PCB Circuit Layout Considerations

Boost converter

1. The path formed from the input capacitor to the inductor and BOT_SW3 with the low-side current-sense resistor must have short leads and PC trace lengths. The same applies for the trace from the inductor to Schottky diode D1 to the C_{OUT1} capacitor. Connect the negative terminal of the input capacitor and the negative terminal of the sense resistor together with short trace lengths.
2. The overcurrent-sensing shunt resistor requires noise filtering, and the filter capacitor must be close to the IC pin.

Buck Converter

1. Connect the drain of TOP_SW1 and TOP_SW2 together with the positive terminal of input capacitor C_{OUT1}. The trace length between these terminals must be short.
2. Connect a local decoupling capacitor between the drain of TOP_SWx and the source of BOT_SWx.
3. The Kelvin-current sensing for the shunt resistor has traces with minimum spacing, routed in parallel with each other. Place any filtering capacitors for noise near the IC pins.
4. The resistor divider for sensing the output voltage connects between the positive terminal of either respective output capacitor and C_{OUTA} or C_{OUTB} and the IC signal ground. Do not locate these components and their traces near any switching nodes or high-current traces.

Other Considerations

1. Short PGNDx and AGND to the thermal pad. Use a star-ground configuration if connecting to a non-ground plane system. Use tie-ins for the EXTSUP capacitor, compensation-network ground, and voltage-sense feedback ground networks to this star ground.
2. Connect a compensation network between the compensation pins and IC signal ground. Connect the oscillator resistor (frequency setting) between the RT pin and IC signal ground. These sensitive circuits must not be located near nodes showing high dv/dt; these include the gate-drive outputs, phase pins, and boost circuits (bootstrap).
3. Reduce the surface area of the high-current-carrying loops to a minimum by ensuring optimal component placement. Locate the bypass capacitors as close as possible to the respective power and ground pins.

PCB Layout

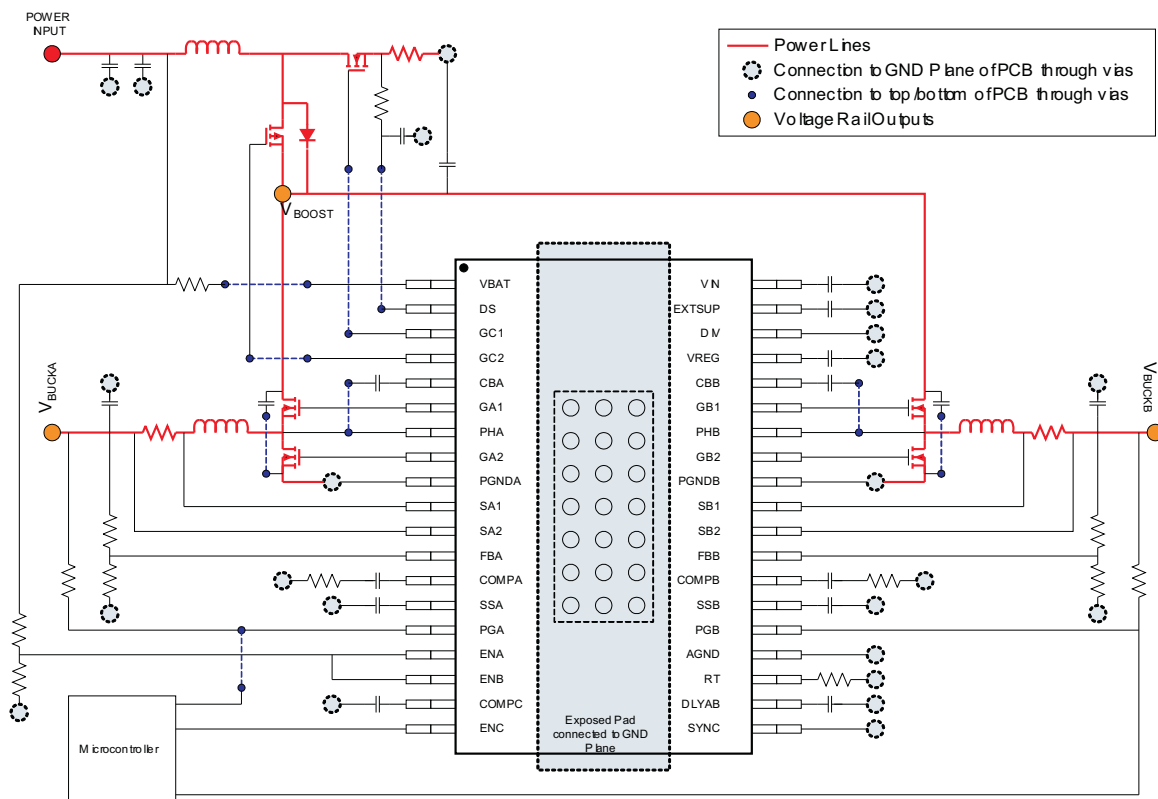

REVISION HISTORY

Changes from Original (August 2013) to Revision A	Page
• Changed 文档状态从产品预览改为生成数据	1

PACKAGING INFORMATION

Orderable Device	Status (1)	Package Type	Package Drawing	Pins	Package Qty	Eco Plan (2)	Lead finish/ Ball material (6)	MSL Peak Temp (3)	Op Temp (°C)	Device Marking (4/5)	Samples
TPS43330AQDAPRQ1	ACTIVE	HTSSOP	DAP	38	2000	RoHS & Green	NIPDAU	Level-3-260C-168 HR	-40 to 125	TPS43330A	Samples

(1) The marketing status values are defined as follows:

ACTIVE: Product device recommended for new designs.

LIFEBUY: TI has announced that the device will be discontinued, and a lifetime-buy period is in effect.

NRND: Not recommended for new designs. Device is in production to support existing customers, but TI does not recommend using this part in a new design.

PREVIEW: Device has been announced but is not in production. Samples may or may not be available.

OBSELETE: TI has discontinued the production of the device.

(2) **RoHS:** TI defines "RoHS" to mean semiconductor products that are compliant with the current EU RoHS requirements for all 10 RoHS substances, including the requirement that RoHS substance do not exceed 0.1% by weight in homogeneous materials. Where designed to be soldered at high temperatures, "RoHS" products are suitable for use in specified lead-free processes. TI may reference these types of products as "Pb-Free".

RoHS Exempt: TI defines "RoHS Exempt" to mean products that contain lead but are compliant with EU RoHS pursuant to a specific EU RoHS exemption.

Green: TI defines "Green" to mean the content of Chlorine (Cl) and Bromine (Br) based flame retardants meet JS709B low halogen requirements of <=1000ppm threshold. Antimony trioxide based flame retardants must also meet the <=1000ppm threshold requirement.

(3) MSL, Peak Temp. - The Moisture Sensitivity Level rating according to the JEDEC industry standard classifications, and peak solder temperature.

(4) There may be additional marking, which relates to the logo, the lot trace code information, or the environmental category on the device.

(5) Multiple Device Markings will be inside parentheses. Only one Device Marking contained in parentheses and separated by a "-" will appear on a device. If a line is indented then it is a continuation of the previous line and the two combined represent the entire Device Marking for that device.

(6) Lead finish/Ball material - Orderable Devices may have multiple material finish options. Finish options are separated by a vertical ruled line. Lead finish/Ball material values may wrap to two lines if the finish value exceeds the maximum column width.

Important Information and Disclaimer:The information provided on this page represents TI's knowledge and belief as of the date that it is provided. TI bases its knowledge and belief on information provided by third parties, and makes no representation or warranty as to the accuracy of such information. Efforts are underway to better integrate information from third parties. TI has taken and continues to take reasonable steps to provide representative and accurate information but may not have conducted destructive testing or chemical analysis on incoming materials and chemicals. TI and TI suppliers consider certain information to be proprietary, and thus CAS numbers and other limited information may not be available for release.

In no event shall TI's liability arising out of such information exceed the total purchase price of the TI part(s) at issue in this document sold by TI to Customer on an annual basis.

TAPE AND REEL INFORMATION

QUADRANT ASSIGNMENTS FOR PIN 1 ORIENTATION IN TAPE

*All dimensions are nominal

Device	Package Type	Package Drawing	Pins	SPQ	Reel Diameter (mm)	Reel Width W1 (mm)	A0 (mm)	B0 (mm)	K0 (mm)	P1 (mm)	W (mm)	Pin1 Quadrant
TPS43330AQDAPRQ1	HTSSOP	DAP	38	2000	330.0	24.4	8.6	13.0	1.8	12.0	24.0	Q1

TAPE AND REEL BOX DIMENSIONS

*All dimensions are nominal

Device	Package Type	Package Drawing	Pins	SPQ	Length (mm)	Width (mm)	Height (mm)
TPS43330AQDAPRQ1	HTSSOP	DAP	38	2000	350.0	350.0	43.0

THERMAL PAD MECHANICAL DATA

DAP (R-PDSO-G38)

PowerPAD™ PLASTIC SMALL OUTLINE

THERMAL INFORMATION

This PowerPAD™ package incorporates an exposed thermal pad that is designed to be attached to a printed circuit board (PCB). The thermal pad must be soldered directly to the PCB. After soldering, the PCB can be used as a heatsink. In addition, through the use of thermal vias, the thermal pad can be attached directly to the appropriate copper plane shown in the electrical schematic for the device, or alternatively, can be attached to a special heatsink structure designed into the PCB. This design optimizes the heat transfer from the integrated circuit (IC).

For additional information on the PowerPAD package and how to take advantage of its heat dissipating abilities, refer to Technical Brief, PowerPAD Thermally Enhanced Package, Texas Instruments Literature No. SLMA002 and Application Brief, PowerPAD Made Easy, Texas Instruments Literature No. SLMA004. Both documents are available at www.ti.com.

The exposed thermal pad dimensions for this package are shown in the following illustration.

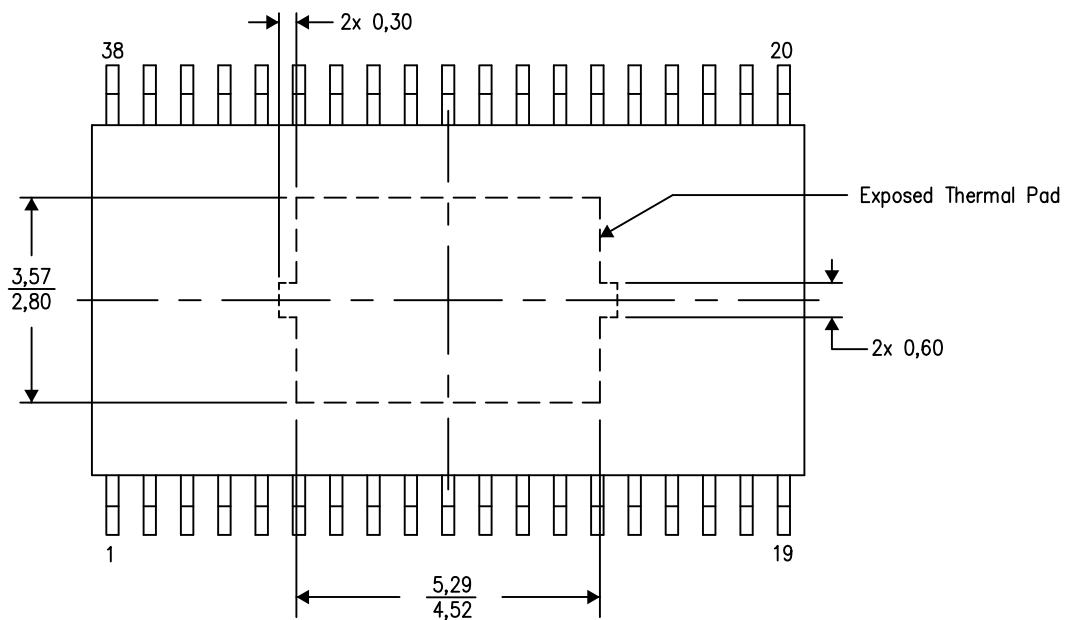

Top View
Exposed Thermal Pad Dimensions

4206319-9/M 09/13

NOTE: All linear dimensions are in millimeters

PowerPAD is a trademark of Texas Instruments.

LAND PATTERN DATA

DAP (R-PDSO-G38) PowerPAD™ PLASTIC SMALL OUTLINE PACKAGE

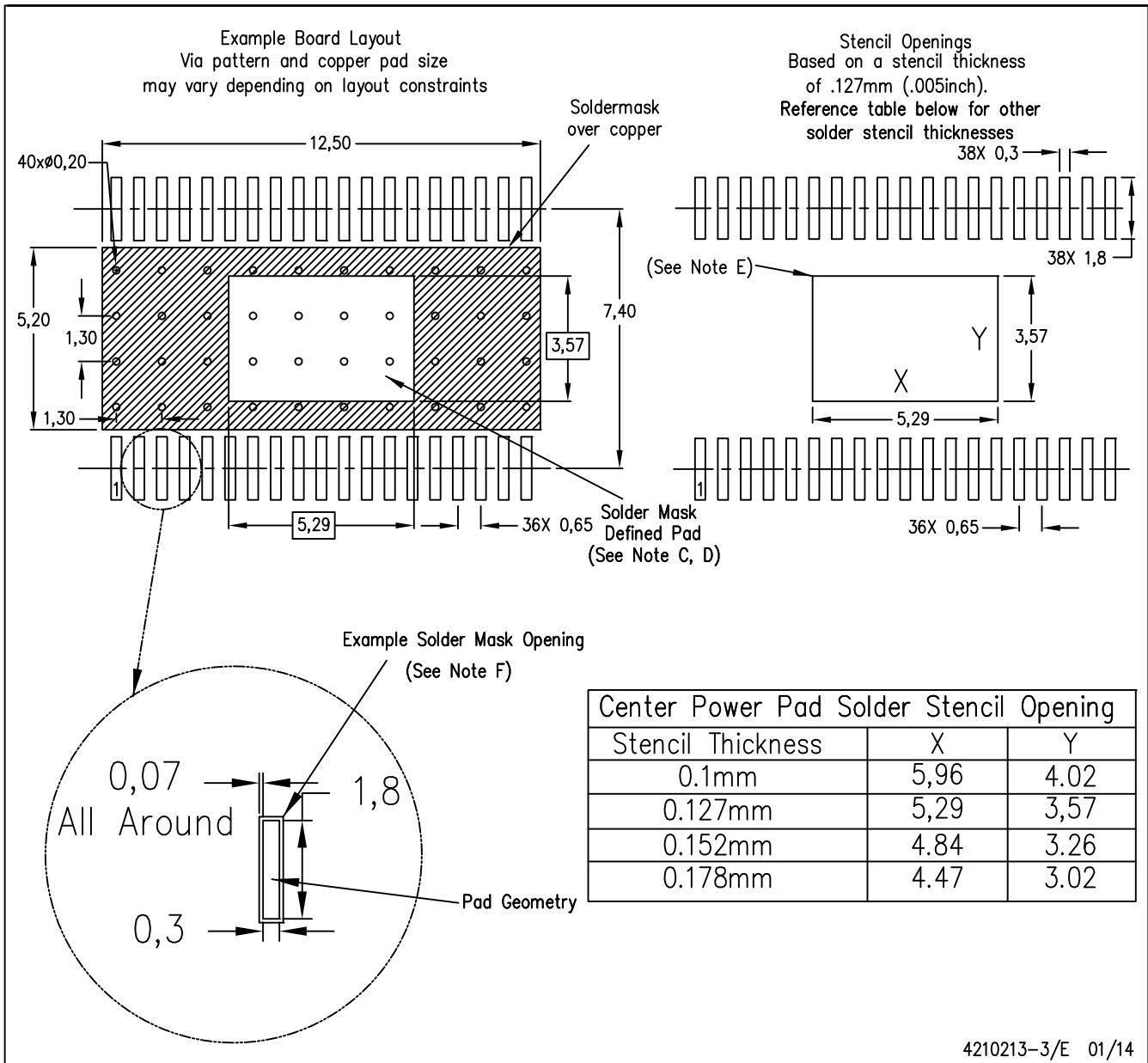

- NOTES:
- All linear dimensions are in millimeters.
 - This drawing is subject to change without notice.
 - Customers should place a note on the circuit board fabrication drawing not to alter the center solder mask defined pad.
 - This package is designed to be soldered to a thermal pad on the board. Refer to Technical Brief, PowerPad Thermally Enhanced Package, Texas Instruments Literature No. SLMA002, SLMA004, and also the Product Data Sheets for specific thermal information, via requirements, and recommended board layout. These documents are available at www.ti.com <<http://www.ti.com>>. Publication IPC-7351 is recommended for alternate designs.
 - Laser cutting apertures with trapezoidal walls and also rounding corners will offer better paste release. Customers should contact their board assembly site for stencil design recommendations. Refer to IPC-7525 for other stencil recommendations.
 - Contact the board fabrication site for recommended soldermask tolerances.

PowerPAD is a trademark of Texas Instruments

重要声明和免责声明

TI“按原样”提供技术和可靠性数据（包括数据表）、设计资源（包括参考设计）、应用或其他设计建议、网络工具、安全信息和其他资源，不保证没有瑕疵且不做任何明示或暗示的担保，包括但不限于对适销性、某特定用途方面的适用性或不侵犯任何第三方知识产权的暗示担保。

这些资源可供使用 TI 产品进行设计的熟练开发人员使用。您将自行承担以下全部责任：(1) 针对您的应用选择合适的 TI 产品，(2) 设计、验证并测试您的应用，(3) 确保您的应用满足相应标准以及任何其他功能安全、信息安全、监管或其他要求。

这些资源如有变更，恕不另行通知。TI 授权您仅可将这些资源用于研发本资源所述的 TI 产品的应用。严禁对这些资源进行其他复制或展示。您无权使用任何其他 TI 知识产权或任何第三方知识产权。您应全额赔偿因在这些资源的使用中对 TI 及其代表造成的任何索赔、损害、成本、损失和债务，TI 对此概不负责。

TI 提供的产品受 [TI 的销售条款](#) 或 [ti.com](#) 上其他适用条款/TI 产品随附的其他适用条款的约束。TI 提供这些资源并不会扩展或以其他方式更改 TI 针对 TI 产品发布的适用的担保或担保免责声明。

TI 反对并拒绝您可能提出的任何其他或不同的条款。

邮寄地址：Texas Instruments, Post Office Box 655303, Dallas, Texas 75265

Copyright © 2023，德州仪器 (TI) 公司