

UCC21750 适用于 SiC/IGBT 并具有主动保护、隔离式模拟感应和高 CMTI 的 10A 拉电流/灌电流增强型隔离式单通道栅极驱动器

1 特性

- 5.7kV_{RMS} 单通道隔离式栅极驱动器
- 高达 2121V_{pk} 的 SiC MOSFET 和 IGBT
- 33V 最大输出驱动电压 (VDD - VEE)
- ±10A 驱动强度和分离输出
- 150V/ns 最小 CMTI
- 具有 200ns 快速响应时间的 DESAT 保护
- 4A 内部有源米勒钳位
- 发生故障时的 400mA 软关断
- 具有 PWM 输出的隔离式模拟传感器
 - 采用 NTC、PTC 或热敏二极管的温度感应
 - 高电压直流链路或相电压
- 过流警报 $\overline{\text{FLT}}$ 和通过 $\overline{\text{RST/EN}}$ 重置
- 针对 $\overline{\text{RST/EN}}$ 的快速启用和禁用响应
- 抑制输入引脚上的 <40ns 噪声瞬态和脉冲
- RDY 上的 12V VDD UVLO (具有电源正常指示功能)
- 具有高达 5V 过冲/欠冲瞬态电压抗扰度的输入/输出
- 130 ns (最大) 传播延迟和 30 ns (最大) 脉冲/器件间偏移
- SOIC-16 DW 封装, 爬电距离和间隙 > 8mm
- 工作结温范围: -40°C 至 +150°C
- 安全相关认证:
 - 符合 DIN EN IEC 60747-17 (VDE 0884-17) 标准的增强型绝缘
 - UL 1577 组件认证计划

2 应用

- 工业电机驱动
- 服务器、电信和工业电源
- 不间断电源 (UPS)
- 光伏逆变器

3 说明

UCC21750 是一款电隔离单通道栅极驱动器, 设计用于直流工作电压高达 2121V 的 SiC MOSFET 和 IGBT, 具有先进的保护功能、出色的动态性能和稳健性。UCC21750 具有高达 ±10A 的峰值拉电流和灌电流。

输入侧通过 SiO₂ 电容隔离技术与输出侧相隔离, 支持高达 1.5kV_{RMS} 的工作电压、12.8kV_{PK} 的浪涌抗扰度, 隔离层寿命超过 40 年, 并提供较低的器件间偏移, 共模噪声抗扰度 (CMTI) 大于 150V/ns。

UCC21750 包括先进的保护特性, 如快速过流和短路检测、分流电流检测支持、故障报告、有源米勒钳位、输入和输出侧电源 UVLO (用于优化 SiC 和 IGBT 开关行为和稳健性)。可以利用隔离式模拟至 PWM 传感器更轻松地感测温度或电压, 从而进一步提高驱动器的多功能性并简化系统设计工作量、尺寸和成本。

器件信息

器件型号	封装 ⁽¹⁾	封装尺寸 (标称值)
UCC21750	DW SOIC-16	10.3mm × 7.5mm

(1) 如需了解所有可用封装, 请参阅数据表末尾的可订购产品附录。

器件引脚配置

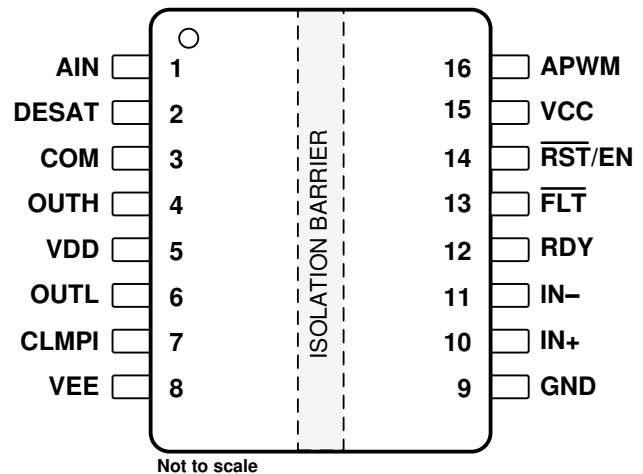

Table of Contents

1 特性	1	7.5 Desaturation (DESAT) Protection.....	21
2 应用	1	8 Detailed Description	23
3 说明	1	8.1 Overview.....	23
4 Revision History	2	8.2 Functional Block Diagram.....	24
5 Pin Configuration and Functions	3	8.3 Feature Description.....	24
6 Specifications	4	8.4 Device Functional Modes.....	30
6.1 Absolute Maximum Ratings.....	4	9 Applications and Implementation	31
6.2 ESD Ratings.....	4	9.1 Application Information.....	31
6.3 Recommended Operating Conditions.....	4	9.2 Typical Application.....	31
6.4 Thermal Information.....	5	10 Power Supply Recommendations	43
6.5 Power Ratings.....	5	11 Layout	44
6.6 Insulation Specifications.....	5	11.1 Layout Guidelines.....	44
6.7 Safety Limiting Values.....	6	11.2 Layout Example.....	45
6.8 Electrical Characteristics.....	6	12 Device and Documentation Support	46
6.9 Safety-Related Certifications.....	8	12.1 Device Support.....	46
6.10 Switching Characteristics.....	9	12.2 Documentation Support.....	46
6.11 Insulation Characteristics Curves.....	10	12.3 接收文档更新通知.....	46
6.12 Typical Characteristics.....	11	12.4 支持资源.....	46
7 Parameter Measurement Information	16	12.5 Trademarks.....	46
7.1 Propagation Delay.....	16	12.6 静电放电警告.....	46
7.2 Input Deglitch Filter.....	17	12.7 术语表.....	46
7.3 Active Miller Clamp.....	18	13 Mechanical, Packaging, and Orderable Information	46
7.4 Undervoltage Lockout (UVLO).....	19		

4 Revision History

注：以前版本的页码可能与当前版本的页码不同

Changes from Revision B (December 2019) to Revision C (January 2023)	Page
• 向特性中添加了安全相关认证.....	1
• Added what to do with unused pins to pin functions table.....	3
• Changed recommended value of decoupling capacitors.....	3
• Added recommended decoupling capacitor layout placement.....	3
• Changed test conditions per DIN EN IEC 60747-17 (VDE 0884-17).....	5
• Changed I _{chg} lower limit to 430uA.....	6
• Changed V _{Ain} lower limit to 0.6V.....	6
• Changed direction of I _{CLMPI} in V _{CLP-CLMPI} test condition.....	6
• Added test condition for soft turn-off current.....	6
• Deleted short circuit clamping max condition.....	6
• Deleted V _{DESATL}	6
• Changed from 150ns to 120ns.....	6
• Changed from 150ns to 148ns.....	6
• Deleted 9600 V from Value column in the V _{IO_{TM}} row.....	6
• Changed VDE and UL to certified.....	8
• Changed DESAT figure.....	28
• Changed DESAT soft turn-off figure.....	28
• Added function state showing gate driver turning on. Changed RDY condition when VCC is PD.....	30
• Added 节 9.2.3.....	42

Changes from Revision A (May 2019) to Revision B (December 2019)	Page
• 将销售状态从“预告信息”更改为“量产数据”。.....	1
• Deleted test voltage, 9600V, from value column.....	5

5 Pin Configuration and Functions



图 5-1. UCC21750 DW SOIC (16) Top View

表 5-1. Pin Functions

PIN		I/O ⁽¹⁾	DESCRIPTION
NAME	NO.		
AIN	1	I	Isolated analog sensing input, parallel a small capacitor to COM for better noise immunity. Tie to COM if unused.
DESAT	2	I	Desaturation current protection input. Tie to COM if unused.
COM	3	P	Common ground reference, connecting to emitter pin for IGBT and source pin for SiC-MOSFET.
OUTH	4	O	Gate driver output pullup
VDD	5	P	Positive supply rail for gate drive voltage. Bypass with a >10- μ F capacitor to COM to support specified gate driver source peak current capability. Place decoupling capacitor close to the pin.
OUTL	6	O	Gate driver output pull down
CLMPI	7	I	Internal active miller clamp, connecting this pin directly to the gate of the power transistor. Leave floating or tie to VEE if unused.
VEE	8	P	Negative supply rail for gate drive voltage. Bypass with a >10- μ F capacitor to COM to support specified gate driver sink peak current capability. Place decoupling capacitor close to the pin.
GND	9	P	Input power supply and logic ground reference.
IN+	10	I	Non-inverting gate driver control input. Tie to VCC if unused.
IN-	11	I	Inverting gate driver control input. Tie to GND if unused.
RDY	12	O	Power good for VCC-GND and VDD-COM. RDY is open drain configuration and can be paralleled with other RDY signals.
FLT	13	O	Active low fault alarm output upon over current or short circuit. $\overline{\text{FLT}}$ is in open drain configuration and can be paralleled with other faults.
RST/EN	14	I	The $\overline{\text{RST/EN}}$ serves two purposes: 1) Enable / shutdown of the output side. The FET is turned off by a regular turn-off, if terminal EN is set to low; 2) Resets the DESAT condition signaled on $\overline{\text{FLT}}$ pin. if terminal $\overline{\text{RST/EN}}$ is set to low for more than 1000ns. A reset of signal $\overline{\text{FLT}}$ is asserted at the rising edge of terminal $\overline{\text{RST/EN}}$. For automatic RESET function, this pin only serves as an EN pin. Enable / shutdown of the output side. The FET is turned off by a regular turn-off, if terminal EN is set to low.
VCC	15	P	Input power supply from 3 V to 5.5 V. Bypass with a >1- μ F capacitor to GND. Place decoupling capacitor close to the pin.
APWM	16	O	Isolated analog sensing PWM output. Leave floating if unused.

(1) P = Power, G = Ground, I = Input, O = Output

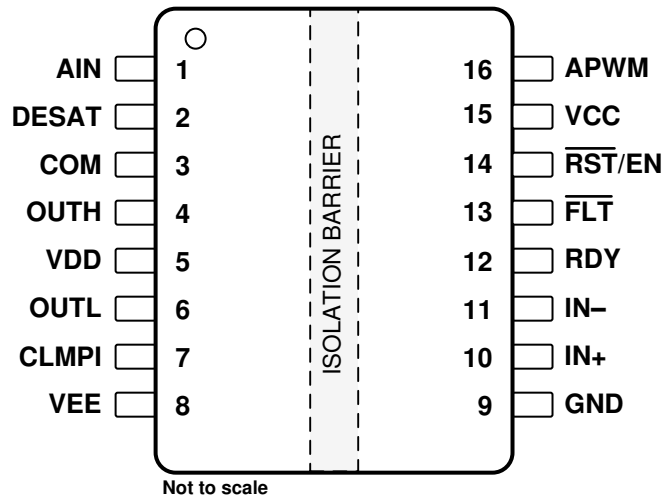
6 Specifications

6.1 Absolute Maximum Ratings

over operating free-air temperature range (unless otherwise noted)⁽¹⁾

PARAMETER		MIN	MAX	UNIT	
VCC	VCC – GND	- 0.3	6	V	
VDD	VDD – COM	- 0.3	36	V	
VEE	VEE – COM	- 17.5	0.3	V	
V _{MAX}	VDD – VEE	- 0.3	36	V	
IN+, IN -, $\overline{\text{RST}}/\text{EN}$		DC	GND – 0.3	VCC	V
		Transient, less than 100 ns ⁽²⁾	GND – 5.0	VCC+5.0	V
DESAT	Reference to COM	COM – 0.3	VDD+0.3	V	
AIN	Reference to COM	- 0.3	5	V	
OUTH, OUTL, CLMPI		DC	VEE – 0.3	VDD	V
		Transient, less than 100 ns ⁽²⁾	VEE – 5.0	VDD+5.0	V
RDY, FLT, APWM		GND – 0.3	VCC	V	
I _{FLT} , I _{RDY}	FLT, and RDY pin input current		20	mA	
I _{APWM}	APWM pin output current		20	mA	
T _J	Junction temperature range	- 40	150	°C	
T _{stg}	Storage temperature range	- 65	150	°C	

- (1) Operation outside the *Absolute Maximum Ratings* may cause permanent device damage. *Absolute Maximum Ratings* do not imply functional operation of the device at these or any other conditions beyond those listed under *Recommended Operating Conditions*. If outside the *Recommended Operating Conditions* but within the *Absolute Maximum Ratings*, the device may not be fully functional, and this may affect device reliability, functionality, performance, and shorten the device lifetime.
- (2) Values are verified by characterization on bench.

6.2 ESD Ratings

		VALUE	UNIT
V _(ESD)	Electrostatic discharge	Human-body model (HBM), per AEC Q100-002 ⁽¹⁾	±4000
		Charged-device model (CDM), per AEC Q100-011	±1500

- (1) AEC Q100-002 indicates that HBM stressing shall be in accordance with the ANSI/ESDA/JEDEC JS-001 specification.

6.3 Recommended Operating Conditions

PARAMETER		MIN	MAX	UNIT	
VCC	VCC – GND	3.0	5.5	V	
VDD	VDD – COM	13	33	V	
V _{MAX}	VDD – VEE	-	33	V	
IN+, IN -, $\overline{\text{RST}}/\text{EN}$	Reference to GND	High level input voltage	0.7×VCC	VCC	V
		Low level input voltage	0	0.3×VCC	
AIN	Reference to COM	0.6	4.5	V	
t _{RST/EN}	Minimum pulse width that reset the fault	1000		ns	
T _A	Ambient temperature	- 40	125	°C	
T _J	Junction temperature	- 40	150	°C	

6.4 Thermal Information

THERMAL METRIC ⁽¹⁾		UCC21750	
		DW (SOIC)	
		16 PINS	
Symbol	Description	Value	UNIT
$R_{\theta JA}$	Junction-to-ambient thermal resistance	68.3	°C/W
$R_{\theta JC(top)}$	Junction-to-case (top) thermal resistance	27.5	°C/W
$R_{\theta JB}$	Junction-to-board thermal resistance	32.9	°C/W
ψ_{JT}	Junction-to-top characterization parameter	14.1	°C/W
ψ_{JB}	Junction-to-board characterization parameter	32.3	°C/W

(1) For more information about traditional and new thermal metrics, see the [Semiconductor and IC Package Thermal Metrics](#) application report.

6.5 Power Ratings

PARAMETER	TEST CONDITIONS	Value	UNIT
P_D	Maximum power dissipation (both sides)	985	mW
P_{D1}	Maximum power dissipation by transmitter side	VCC = 5 V, VDD - COM = 20 V, COM - VEE = 5 V, IN+/- = 5 V, 150 kHz, 50% Duty Cycle for a 10-nF load, T _a = 25°C	20
P_{D2}	Maximum power dissipation by receiver side		965

6.6 Insulation Specifications

PARAMETER	TEST CONDITIONS	VALUE	UNIT
GENERAL			
CLR	External clearance ⁽¹⁾	Shortest terminal-to-terminal distance through air	> 8 mm
CPG	External creepage ⁽¹⁾	Shortest terminal-to-terminal distance across the package surface	> 8 mm
DTI	Distance through the insulation	Minimum internal gap (Internal clearance) of the double insulation (2 × 0.0085 mm)	> 17 μm
CTI	Comparative tracking index	DIN EN 60112 (VDE 0303-11); IEC 60112	> 600 V
	Material group	According to IEC 60664 - 1	I
	Overvoltage Category per IEC 60664 - 1	Rated mains voltage ≤ 300 V _{RMS}	I-IV
		Rated mains voltage ≤ 600 V _{RMS}	I-IV
		Rated mains voltage ≤ 1000 V _{RMS}	I-III
DIN EN IEC 60747-17 (VDE 0884-17)⁽²⁾			
V_{IORM}	Maximum repetitive peak isolation voltage	AC voltage (bipolar)	2121 V _{PK}
V_{IOWM}	Maximum isolation working voltage	AC voltage (sine wave) Time dependent dielectric breakdown (TDDB) test	1500 V _{RMS}
		DC voltage	2121 V _{DC}
V_{IMP}	Maximum impulse voltage	Tested in air, 1.2/50- μ s waveform per IEC 62368-1	8000 V _{PK}
V_{IOTM}	Maximum transient isolation voltage	$V_{TEST}=V_{IOTM}$, t = 60 s (qualification test)	8000 V _{PK}
		$V_{TEST}=1.2 \times V_{IOTM}$, t = 1 s (100% production test)	
V_{IOSM}	Maximum surge isolation voltage ⁽³⁾	Test method per IEC 62368-1, 1.2/50 μ s waveform	12800 V _{PK}

6.6 Insulation Specifications (continued)

PARAMETER		TEST CONDITIONS	VALUE	UNIT
q _{pd}	Apparent charge ⁽⁴⁾	Method a: After I/O safety test subgroup 2/3, V _{ini} = V _{IOTM} , t _{ini} = 60 s; V _{pd(m)} = 1.2 × V _{IORM} = 2545 V _{PK} , t _m = 10 s	≤ 5	pC
		Method a: After environmental tests subgroup 1, V _{ini} = V _{IOTM} , t _{ini} = 60 s; V _{pd(m)} = 1.6 × V _{IORM} = 3394 V _{PK} , t _m = 10 s	≤ 5	
		Method b1: At routine test (100% production) and preconditioning (type test) V _{ini} = V _{IOTM} , t _{ini} = 1 s; V _{pd(m)} = 1.875 × V _{IORM} = 3977 V _{PK} , t _m = 1 s	≤ 5	
C _{IO}	Barrier capacitance, input to output ⁽⁵⁾	V _{IO} = 0.5 sin (2 π ft), f = 1 MHz	~ 1	pF
R _{IO}	Insulation resistance, input to output ⁽⁵⁾	V _{IO} = 500 V, T _A = 25°C	≥ 10 ¹²	Ω
		V _{IO} = 500 V, 100°C ≤ T _A ≤ 125°C	≥ 10 ¹¹	
		V _{IO} = 500 V at T _S = 150°C	≥ 10 ⁹	
	Pollution degree		2	
	Climatic category		40/125/21	
UL 1577				
V _{ISO}	Withstand isolation voltage	V _{TEST} = V _{ISO} = 5700 V _{RMS} , t = 60 s (qualification); V _{TEST} = 1.2 × V _{ISO} = 6840 V _{RMS} , t = 1 s (100% production)	5700	V _{RMS}

- Apply creepage and clearance requirements according to the specific equipment isolation standards of an application. Care must be taken to maintain the creepage and clearance distance of a board design to ensure that the mounting pads of the isolator on the printed circuit board (PCB) do not reduce this distance. Creepage and clearance on a PCB become equal in certain cases. Techniques such as inserting grooves and ribs on the PCB are used to help increase these specifications.
- This coupler is suitable for safe electrical insulation only within the safety ratings. Compliance with the safety ratings shall be ensured by means of suitable protective circuits.
- Testing is carried out in air or oil to determine the intrinsic surge immunity of the isolation barrier.
- Apparent charge is electrical discharge caused by a partial discharge (pd).
- All pins on each side of the barrier tied together creating a two-terminal device.

6.7 Safety Limiting Values

Safety limiting⁽¹⁾ intends to minimize potential damage to the isolation barrier upon failure of input or output circuitry. A failure of the I/O can allow low resistance to ground or the supply and, without current limiting, dissipate sufficient power to overheat the die and damage the isolation barrier, potentially leading to secondary system failures.

PARAMETER		TEST CONDITIONS	MIN	TYP	MAX	UNIT
I _S	Safety input, output, or supply current	R _{θJA} = 68.3°C/W, V _{DD} = 15 V, V _{EE} = -5 V, T _J = 150°C, T _A = 25°C			61	mA
		R _{θJA} = 68.3°C/W, V _{DD} = 20 V, V _{EE} = -5 V, T _J = 150°C, T _A = 25°C			49	
P _S	Safety input, output, or total power	R _{θJA} = 68.3°C/W, V _{DD} = 20 V, V _{EE} = -5 V, T _J = 150°C, T _A = 25°C			1220	mW
T _S	Safety temperature				150	°C

- The safety-limiting constraint is the maximum junction temperature specified in the data sheet. The power dissipation and junction-to-air thermal impedance of the device installed in the application hardware determines the junction temperature. The assumed junction-to-air thermal resistance in the [Thermal Information](#) table is that of a device installed on a high-K test board for leaded surface-mount packages. The power is the recommended maximum input voltage times the current. The junction temperature is then the ambient temperature plus the power times the junction-to-air thermal resistance.

6.8 Electrical Characteristics

VCC = 3.3 V or 5.0 V, 1-μF capacitor from VCC to GND, VDD – COM = 20 V, 18 V or 15 V, COM – VEE = 0 V, 5 V, 8 V or 15 V, C_L = 100 pF, -40°C < T_J < 150°C (unless otherwise noted)^{(1) (2)}.

PARAMETER	TEST CONDITIONS	MIN	TYP	MAX	UNIT
VCC UVLO THRESHOLD AND DELAY					

6.8 Electrical Characteristics (continued)

VCC = 3.3 V or 5.0 V, 1- μ F capacitor from VCC to GND, VDD - COM = 20 V, 18 V or 15 V, COM - VEE = 0 V, 5 V, 8 V or 15 V, C_L = 100 pF, -40°C < T_J < 150°C (unless otherwise noted)^{(1) (2)}.

PARAMETER		TEST CONDITIONS	MIN	TYP	MAX	UNIT
V _{VCC_ON}	VCC - GND		2.55	2.7	2.85	V
V _{VCC_OFF}			2.35	2.5	2.65	
V _{VCC_HYS}				0.2		
t _{VCCFIL}	VCC UVLO Deglitch time		10			μ s
t _{VCC+ to OUT}	VCC UVLO on delay to output high	IN+ = VCC, IN - = GND	28	37.8	50	
t _{VCC- to OUT}	VCC UVLO off delay to output low		5	10	15	
t _{VCC+ to RDY}	VCC UVLO on delay to RDY high	RST/EN = VCC	30	37.8	50	
t _{VCC- to RDY}	VCC UVLO off delay to RDY low		5	10	15	
VDD UVLO THRESHOLD AND DELAY						
V _{VDD_ON}	VDD - COM		10.5	12.0	12.8	V
V _{VDD_OFF}			9.9	10.7	11.8	
V _{VDD_HYS}				0.8		
t _{VDDFIL}	VDD UVLO Deglitch time		5			μ s
t _{VDD+ to OUT}	VDD UVLO on delay to output high	IN+ = VCC, IN - = GND	2	5	8	
t _{VDD- to OUT}	VDD UVLO off delay to output low		5	10		
t _{VDD+ to RDY}	VDD UVLO on delay to RDY high	RST/EN = FLT=High		10	15	
t _{VDD- to RDY}	VDD UVLO off delay to RDY low		10	15		
VCC, VDD QUIESCENT CURRENT						
I _{VCCQ}	VCC quiescent current	OUT(H) = High, f _S = 0Hz, AIN = 2 V	2.5	3	4	mA
		OUT(L) = Low, f _S = 0Hz, AIN = 2 V	1.45	2	2.75	
I _{VDDQ}	VDD quiescent current	OUT(H) = High, f _S = 0Hz, AIN = 2 V	3.6	4	5.9	mA
		OUT(L) = Low, f _S = 0Hz, AIN = 2 V	3.1	3.7	5.3	
LOGIC INPUTS — IN+, IN - and RST/EN						
V _{INH}	Input high threshold	V _{CC} = 3.3 V		1.85	2.31	V
V _{INL}	Input low threshold	V _{CC} = 3.3 V	0.99	1.52		V
V _{INHYS}	Input threshold hysteresis	V _{CC} = 3.3 V		0.33		V
I _{IH}	Input high level input leakage current	V _{IN} = VCC		90		μ A
I _{IL}	Input low level input leakage	V _{IN} = GND		- 90		μ A
R _{IND}	Input pins pull down resistance	see Detailed Description for more information		55		k Ω
R _{INU}	Input pins pull up resistance	see Detailed Description for more information		55		
T _{INFIL}	IN+, IN - and RST/EN deglitch (ON and OFF) filter time	f _S = 50 kHz	28	40	60	ns
T _{RSTFIL}	Deglitch filter time to reset /FLT		400	650	800	ns
GATE DRIVER STAGE						
I _{OUT} , I _{OUTH}	Peak source current	C _L = 0.18 μ F, f _S = 1 kHz		10		A
I _{OUT} , I _{OUTL}	Peak sink current				10	
R _{OUTH}	Output pull-up resistance	I _{OUT} = - 0.1 A		2.5		Ω
R _{OUTL}	Output pull-down resistance	I _{OUT} = 0.1 A		0.3		Ω
V _{OUTH}	High level output voltage	I _{OUT} = - 0.2 A, V _{DD} = 18 V		17.5		V
V _{OUTL}	Low level output voltage	I _{OUT} = 0.2 A		60		mV
ACTIVE PULLDOWN						
V _{OUTPD}	Output active pull down on OUT, OUTL	I _{OUTL} or I _{OUT} = 0.1 \times I _{OUT(L)(tpy)} , VDD=OPEN, VEE=COM	1.5	2	2.5	V
INTERNAL ACTIVE MILLER CLAMP						
V _{CLMPH}	Miller clamp threshold voltage	Reference to VEE	1.5	2.0	2.5	V
V _{CLMPI}	Output low clamp voltage	I _{CLMPI} = 1 A		VEE + 0.5		V
I _{CLMPI}	Output low clamp current	V _{CLMPI} = 0 V, VEE = - 2.5 V		4		A
R _{CLMPI}	Miller clamp pull down resistance	I _{CLMPI} = 0.2 A		0.6		Ω

6.8 Electrical Characteristics (continued)

VCC = 3.3 V or 5.0 V, 1- μ F capacitor from VCC to GND, VDD - COM = 20 V, 18 V or 15 V, COM - VEE = 0 V, 5 V, 8 V or 15 V, C_L = 100 pF, -40°C < T_J < 150°C (unless otherwise noted)^{(1) (2)}.

PARAMETER		TEST CONDITIONS	MIN	TYP	MAX	UNIT
t _{DCLMPI}	Miller clamp ON delay time	C _L = 1.8 nF		15	50	ns
SHORT CIRCUIT CLAMPING						
V _{CLP-OUT(H)}	V _{OUT} - VDD, V _{OUTH} - VDD	OUT = Low, I _{OUT(H)} = 500 mA, t _{CLP} = 10 μ s		0.9		V
V _{CLP-OUT(L)}	V _{OUT} - VDD, V _{OUTL} - VDD	OUT = High, I _{OUT(L)} = 500 mA, t _{CLP} = 10 μ s		1.8		V
V _{CLP-CLMPI}	V _{CLMPI} - VDD	OUT = High, I _{CLMPI} = 20 mA, t _{CLP} = 10 μ s		1.0		V
DESAT PROTECTION						
I _{CHG}	Blanking capacitor charge current	V _{DESAT} = 2.0 V	430	500	570	μ A
I _{DCHG}	Blanking capacitor discharge current	V _{DESAT} = 6.0 V	10	15		mA
V _{DESAT}	Detection Threshold		8.5	9.15	9.8	V
t _{DESATLEB}	Leading edge blank time			200	200	ns
t _{DESATFIL}	DESAT deglitch filter		50	140	230	ns
t _{DESATOFF}	DESAT propagation delay to OUT(L) 90%			200	300	ns
t _{DESATFLT}	DESAT to FLT low delay		400	580	750	ns
INTERNAL SOFT TURN-OFF						
I _{STO}	Soft turn-off current on fault conditions	V _{DD} -V _{EE} =20V, V _{OUTL} -COM=8V	250	400	570	mA
ISOLATED TEMPERATURE SENSE AND MONITOR (AIN - APWM)						
V _{AIN}	Analog sensing voltage range		0.6		4.5	V
I _{AIN}	Internal current source	V _{AIN} = 2.5 V, -40°C < T _J < 150°C	196	200	209	μ A
f _{APWM}	APWM output frequency	V _{AIN} = 2.5 V	380	400	420	kHz
BW _{AIN}	AIN - APWM bandwidth			10		kHz
D _{APWM}	APWM Duty cycle	V _{AIN} = 0.6 V	86.5	88	89.5	%
		V _{AIN} = 2.5 V	48.5	50	51.5	
		V _{AIN} = 4.5 V	7.5	10	11.5	
FLT AND RDY REPORTING						
t _{RDYHLD}	VDD UVLO RDY low minimum holding time		0.55		1	ms
t _{FLTMUTE}	Output mute time on fault	Reset fault through RST/EN	0.55		1	ms
R _{ODON}	Open drain output on resistance	I _{ODON} = 5 mA		30		Ω
V _{ODL}	Open drain low output voltage	I _{ODON} = 5 mA			0.3	V
COMMON MODE TRANSIENT IMMUNITY						
CMTI	Common-mode transient immunity		150			V/ns

(1) Current are positive into and negative out of the specified terminal.

(2) All voltages are referenced to COM unless otherwise notified.

6.9 Safety-Related Certifications

VDE	UL
Certified according to DIN EN IEC 60747-17 (VDE 0884-17)	Recognized under UL 1577 Component Recognition Program, CSA Component Acceptance Notice 5A
Reinforced insulation Maximum transient isolation voltage, 8000 V _{PK} ; Maximum repetitive peak isolation voltage, 2121 V _{PK} ; Maximum surge isolation voltage, 8000 V _{PK}	Single protection, 5700 V _{RMS}
Certificate number: 40040142	File Number: E181974

6.10 Switching Characteristics

VCC=5.0V, 1uF capacitor from VCC to GND, VDD - COM=20V, 18V or 15V, COM - VEE = 3V, 5V or 8V, C_L=100pF, - 40°C<T_J<150°C (unless otherwise noted)

PARAMETER		TEST CONDITIONS	MIN	TYP	MAX	UNIT
t _{PDHL}	Propagation delay time - High to Low		60	90	130	ns
t _{PDLH}	Propagation delay time - Low to High		60	90	130	
PWD	Pulse width distortion t _{PDHL} - t _{PDLH}				30	
t _{sk-pp}	Part to Part skew	Rising or Falling Propagation Delay			30	
t _r	Driver output rise time	C _L = 10 nF		33		
t _f	Driver output fall time	C _L = 10 nF		27		
f _{MAX}	Maximum switching frequency				1	MHz

6.11 Insulation Characteristics Curves



图 6-1. Thermal Derating Curve for Limiting Current per VDE



图 6-2. Thermal Derating Curve for Limiting Power per VDE

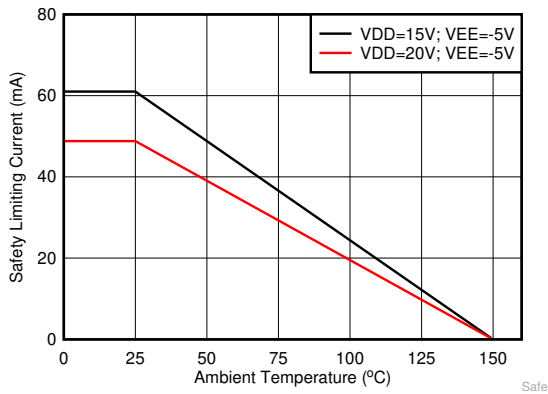

图 6-3. Reinforced Isolation Capacitor Life Time Projection

6.12 Typical Characteristics

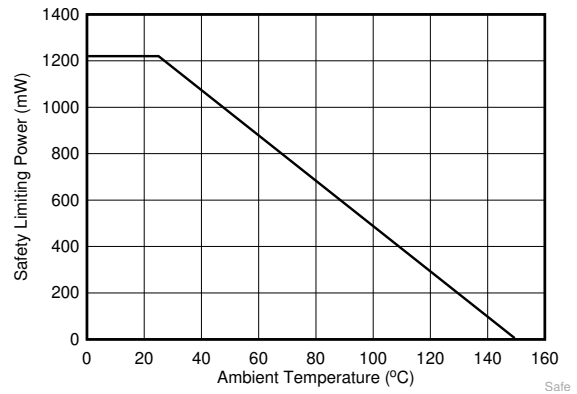

图 6-4. Output High Drive Current vs Temperature

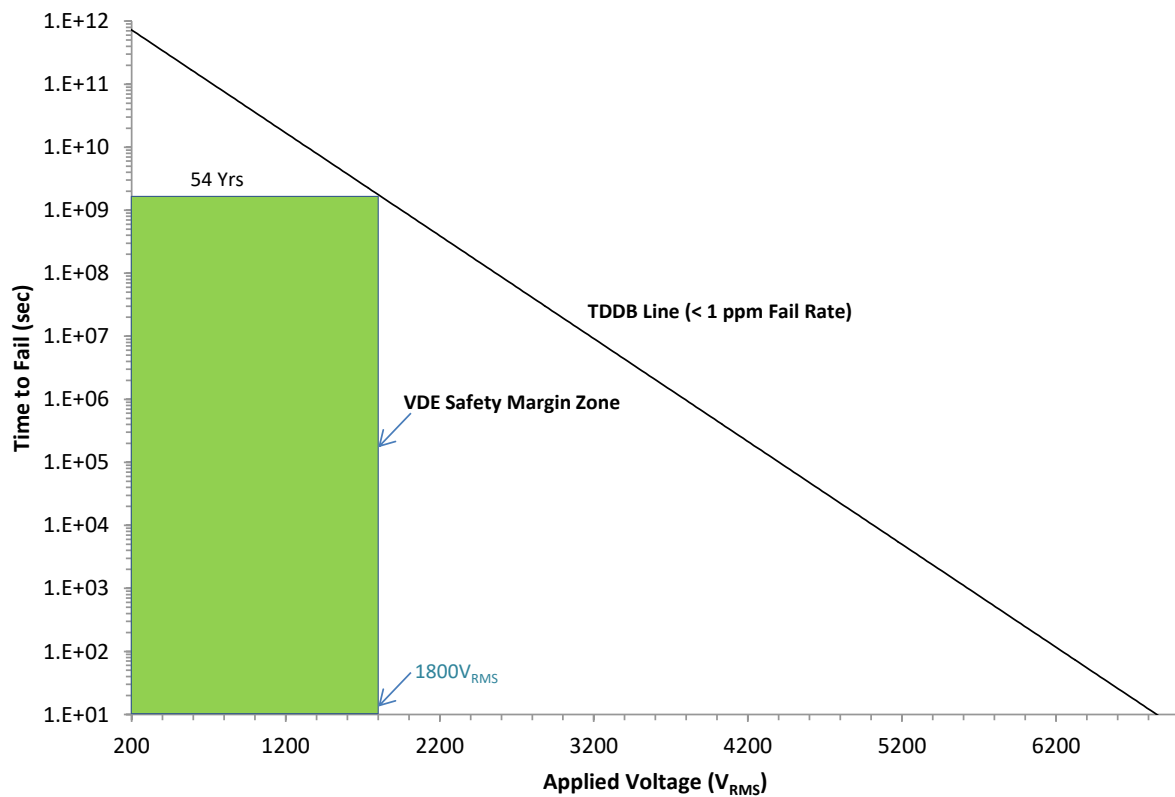

图 6-5. Output Low Driver Current vs Temperature

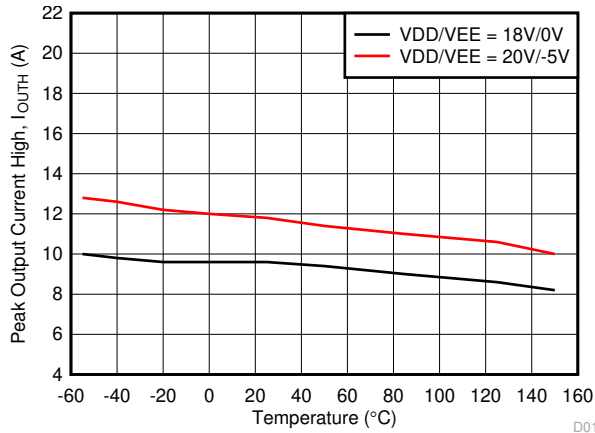

图 6-6. I_{VCCQ} Supply Current vs Temperature

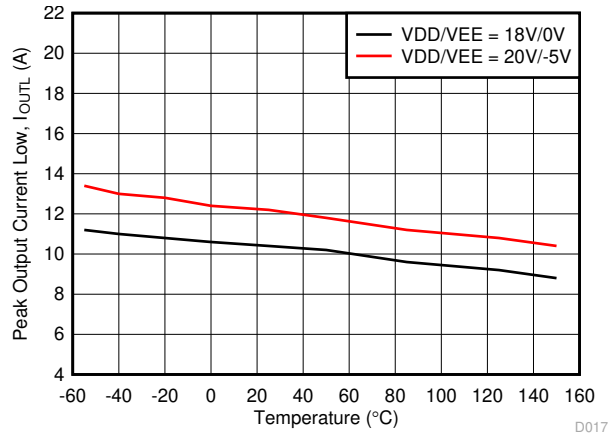

图 6-7. I_{VCCQ} Supply Current vs Temperature

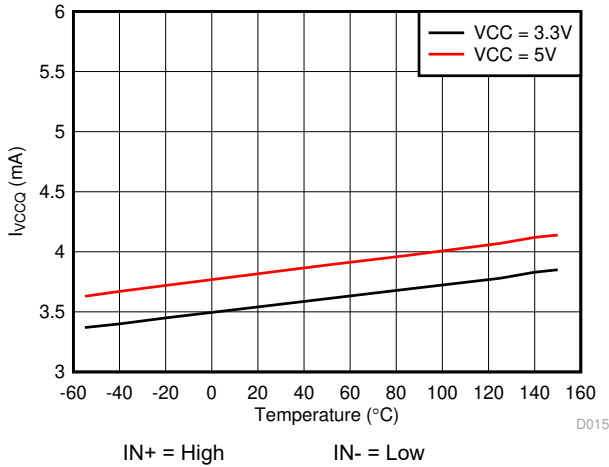

图 6-8. I_{VCCQ} Supply Current vs Input Frequency

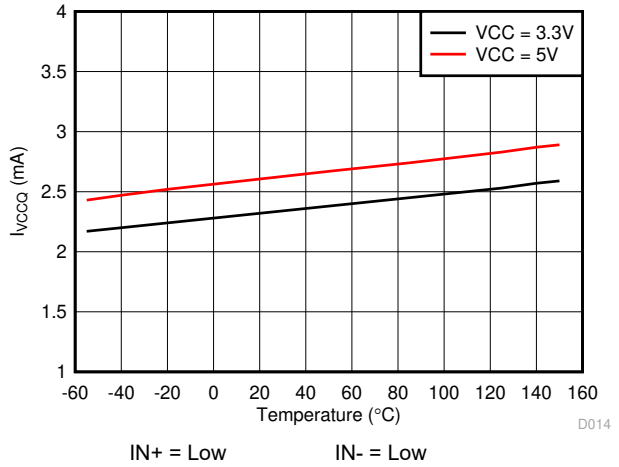

图 6-9. I_{VDDQ} Supply Current vs Temperature

6.12 Typical Characteristics (continued)

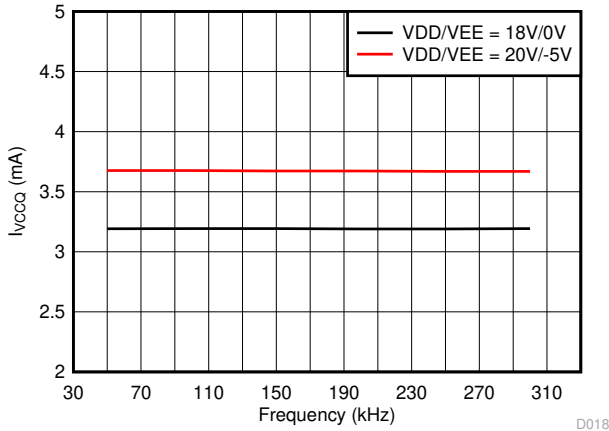

6.12 Typical Characteristics (continued)

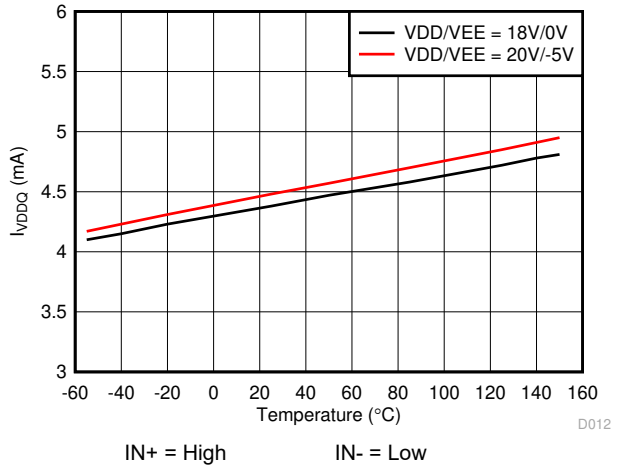
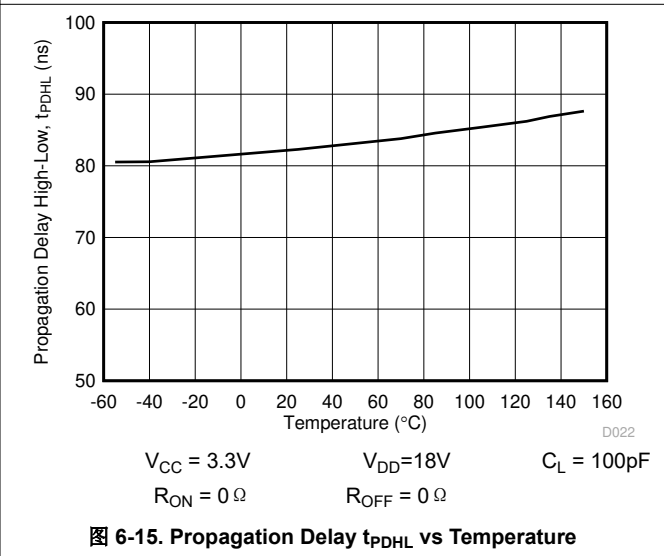
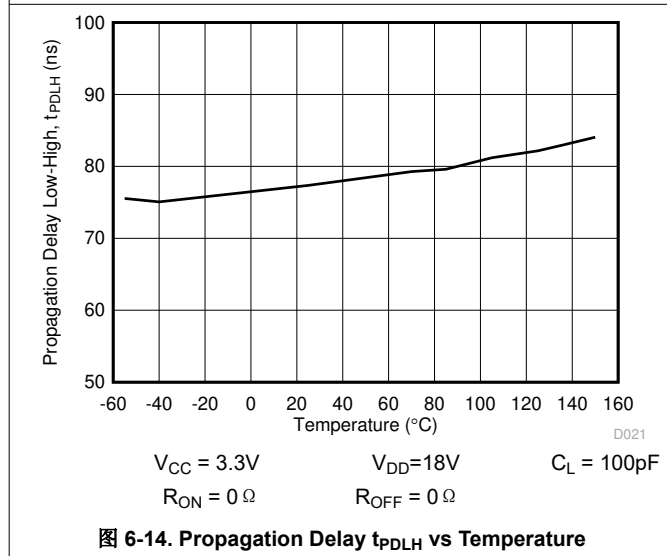
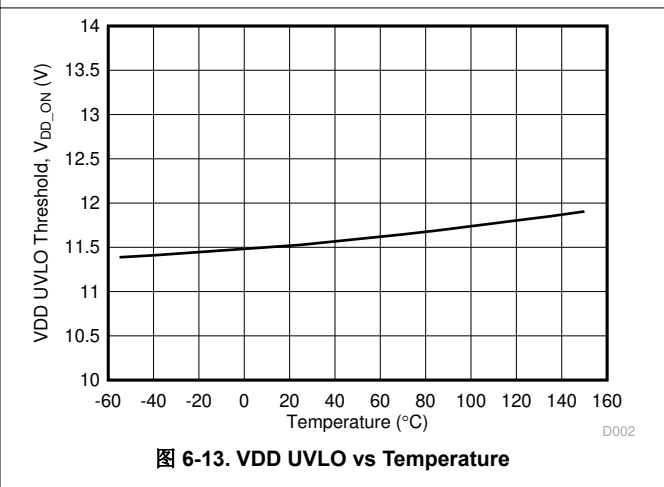
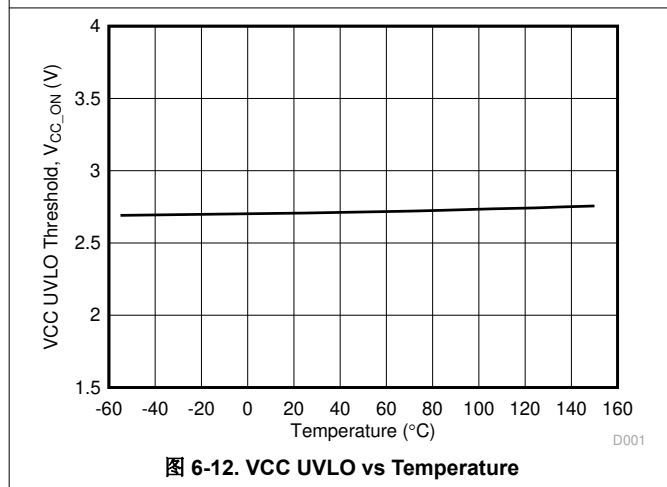
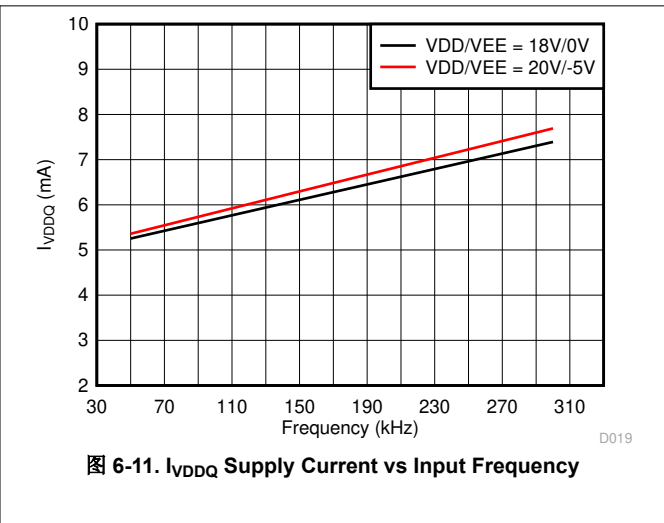
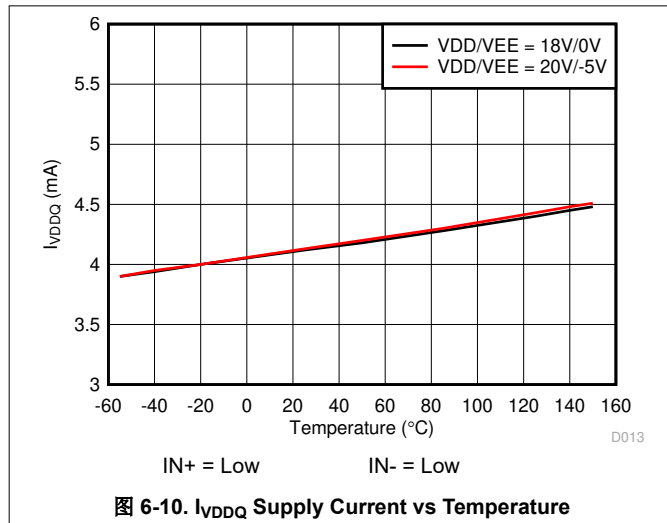
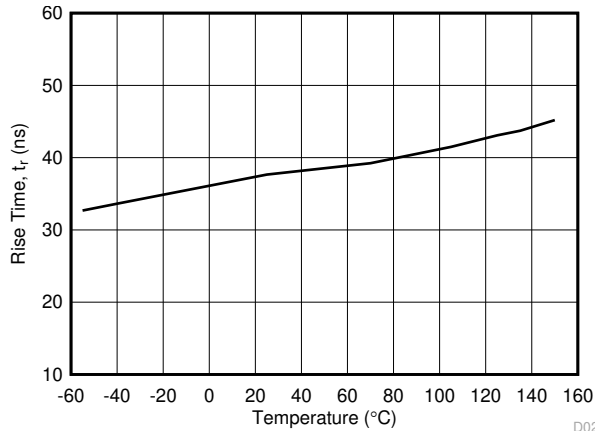

$V_{CC} = 3.3V$ $V_{DD} = 18V$ $C_L = 10nF$
 $R_{ON} = 0\Omega$ $R_{OFF} = 0\Omega$

图 6-16. t_r Rise Time vs Temperature

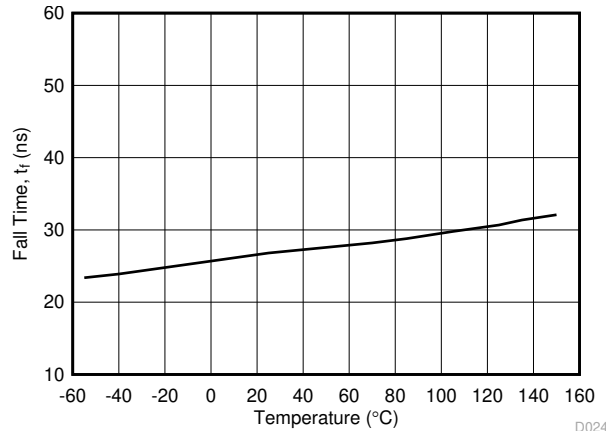

$V_{CC} = 3.3V$ $V_{DD} = 18V$ $C_L = 10nF$
 $R_{ON} = 0\Omega$ $R_{OFF} = 0\Omega$

图 6-17. t_f Fall Time vs Temperature



图 6-18. V_{OUTPD} Output Active Pulldown Voltage vs Temperature



图 6-19. $V_{CLP-OUT(H)}$ Short Circuit Clamping Voltage vs Temperature

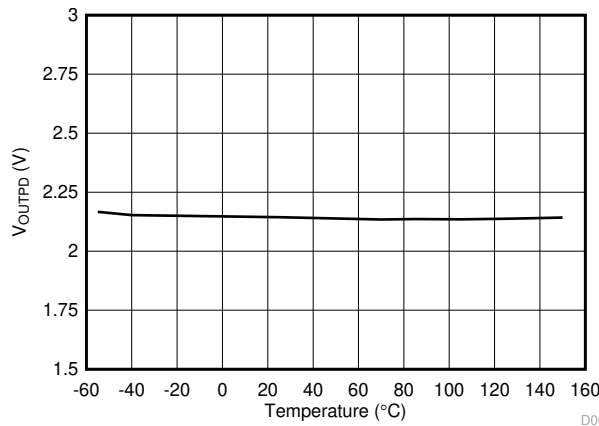

图 6-20. $V_{CLP-OUT(L)}$ Short Circuit Clamping Voltage vs Temperature

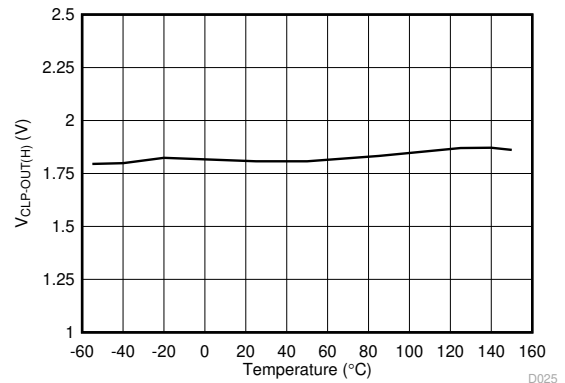

图 6-21. V_{CLMPH} Miller Clamp Threshold Voltage vs Temperature

6.12 Typical Characteristics (continued)

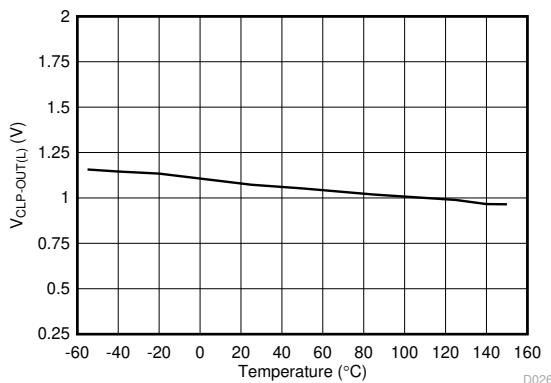

图 6-22. I_{CLMPI} Miller Clamp Sink Current vs Temperature

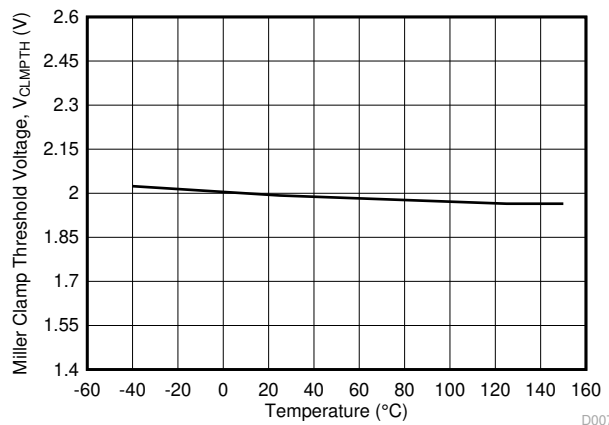
D011

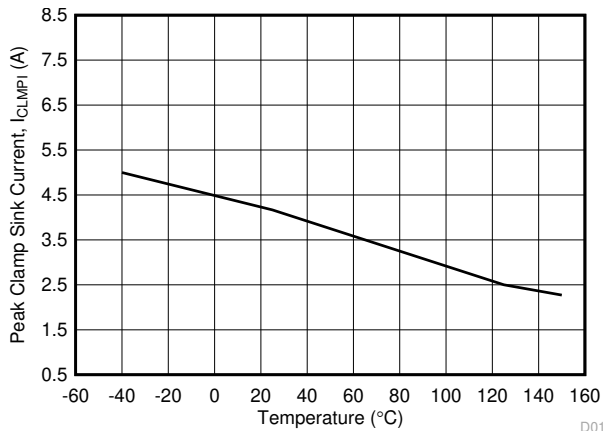

图 6-23. t_{DCLMPI} Miller Clamp ON Delay Time vs Temperature

D010

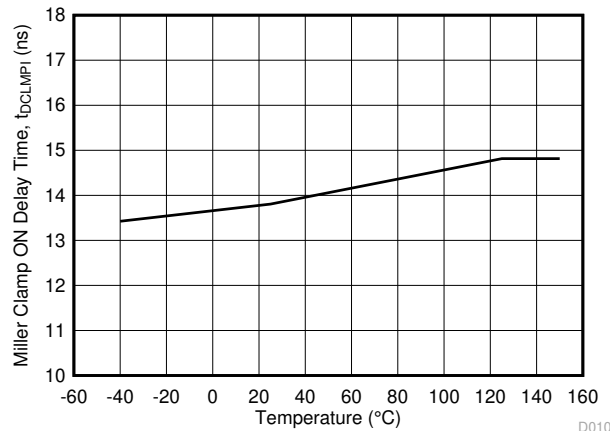

图 6-24. V_{DESAT} DESAT Threshold Voltage vs Temperature

D001

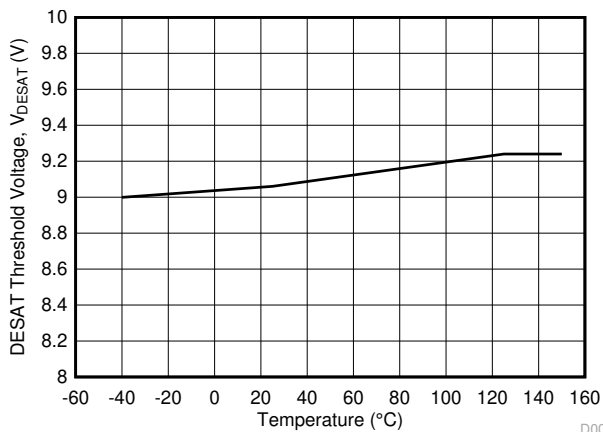

图 6-25. $t_{DESATLEB}$ DESAT Leading Edge Blanking Time vs Temperature

D002

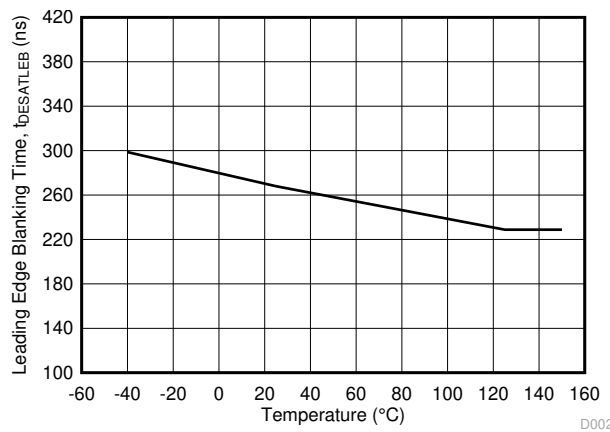

图 6-26. $t_{DESATOFF}$ DESAT Propagation Delay to OUT(L) 90% vs Temperature

D003

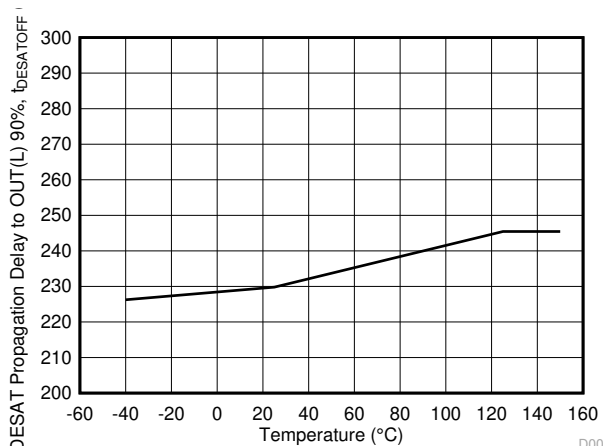

图 6-27. $t_{DESATFLT}$ DESAT Sense to /FLT Low Delay Time vs Temperature

D004

6.12 Typical Characteristics (continued)

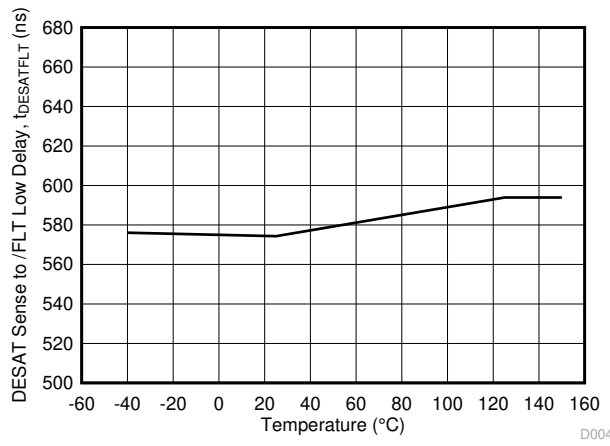

图 6-28. $t_{DESATFIL}$ DESAT Deglitch Filter vs Temperature



图 6-29. I_{CHG} DESAT Charging Current vs Temperature

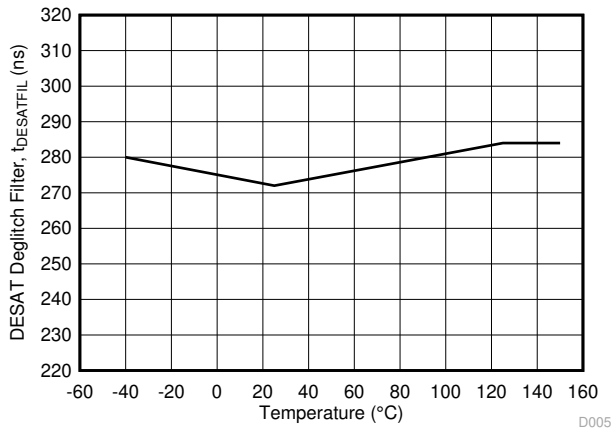

图 6-30. I_{DCHG} DESAT Discharge Current vs Temperature

7 Parameter Measurement Information

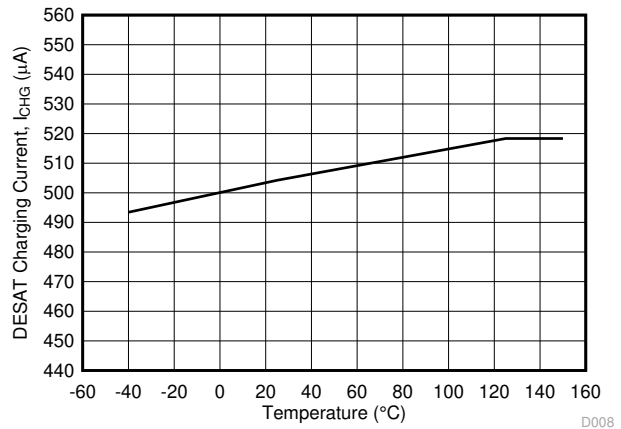
7.1 Propagation Delay

7.1.1 Regular Turn-OFF

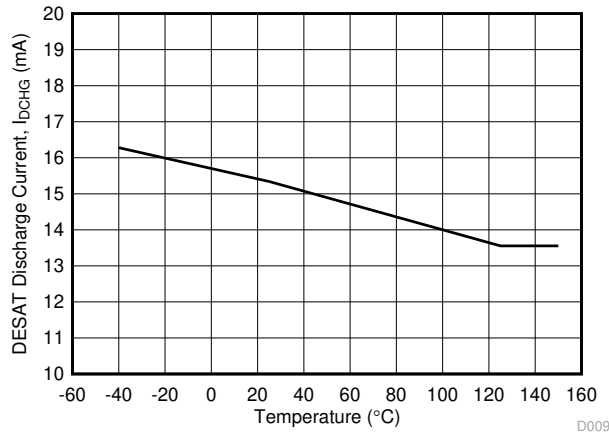
图 7-1 shows the propagation delay measurement for non-inverting configurations. 图 7-2 shows the propagation delay measurement with the inverting configurations.



图 7-1. Non-inverting Logic Propagation Delay Measurement



图 7-2. Inverting Logic Propagation Delay Measurement

7.2 Input Deglitch Filter

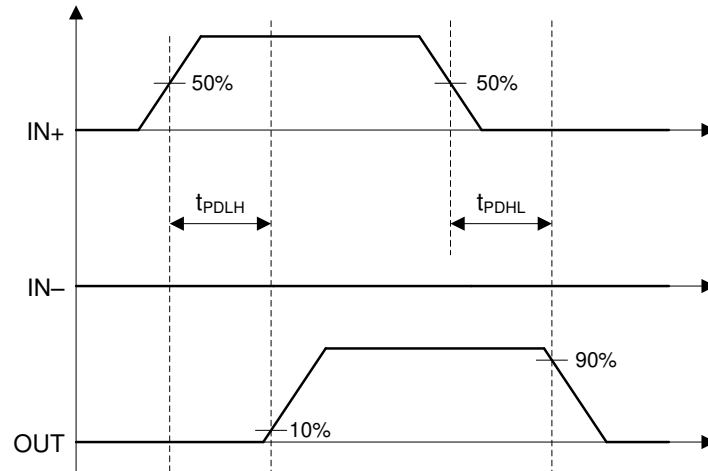
In order to increase the robustness of gate driver over noise transient and accidental small pulses on the input pins, that is, IN+, IN-, RST/EN, a 40-ns deglitch filter is designed to filter out the transients and make sure there is no faulty output responses or accidental driver malfunctions. When the IN+ or IN- PWM pulse is smaller than the input deglitch filter width, T_{INFIL} , there is no responses on OUT drive signal. 图 7-3 and 图 7-4 show the IN+ pin ON and OFF pulse deglitch filter effect. 图 7-5 and 图 7-6 show the IN- pin ON and OFF pulse deglitch filter effect.

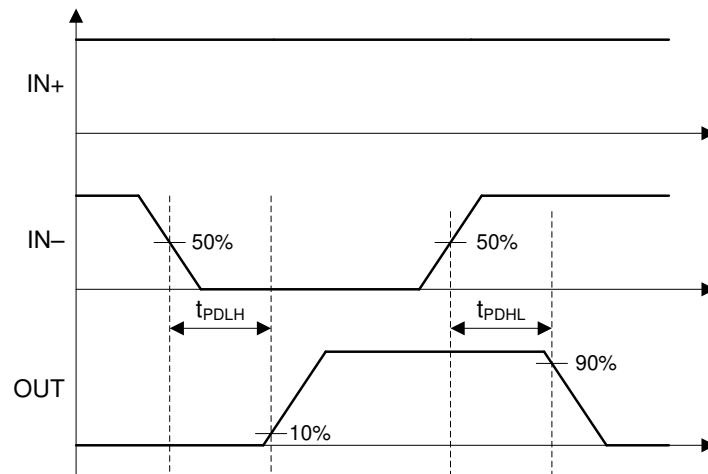

图 7-3. IN+ ON Deglitch Filter



图 7-4. IN+ OFF Deglitch Filter

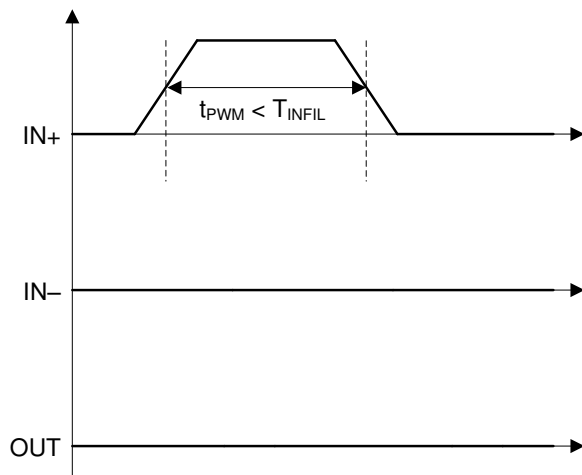

图 7-5. IN- ON Deglitch Filter

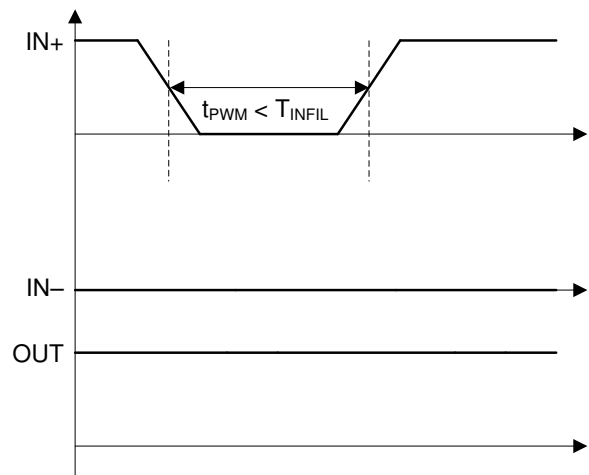

图 7-6. IN- OFF Deglitch Filter

7.3 Active Miller Clamp

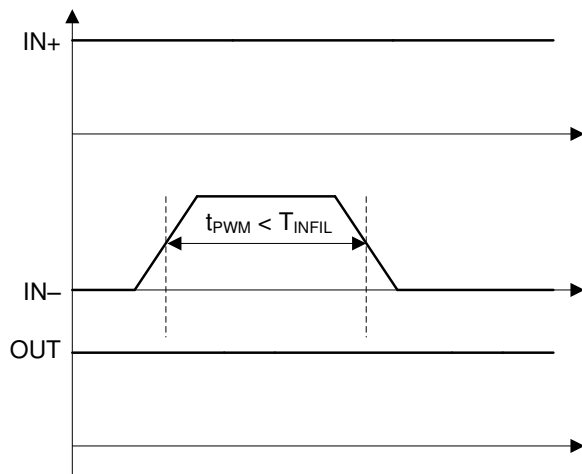
7.3.1 Internal On-chip Active Miller Clamp

For a gate driver application with unipolar bias supply or bipolar supply with small negative turn-off voltage, active miller clamp can help add a additional low impedance path to bypass the miller current and prevent the high dV/dt introduced unintentional turn-on through the miller capacitance. 图 7-7 shows the timing diagram for on-chip internal miller clamp function.

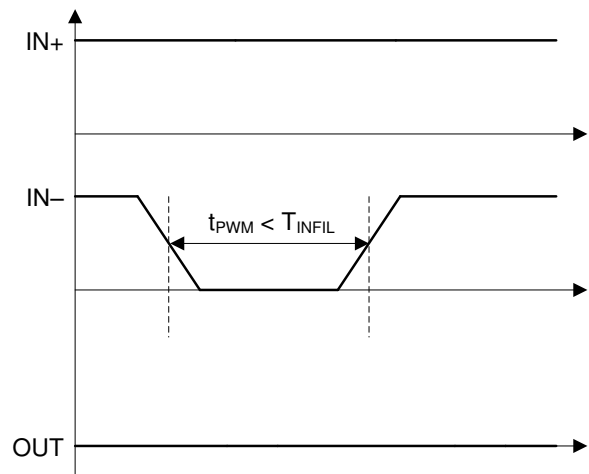

图 7-7. Timing Diagram for Internal Active Miller Clamp Function

7.4 Undervoltage Lockout (UVLO)

UVLO is one of the key protection features designed to protect the system in case of bias supply failures on VCC — primary side power supply, and VDD — secondary side power supply.

7.4.1 VCC UVLO

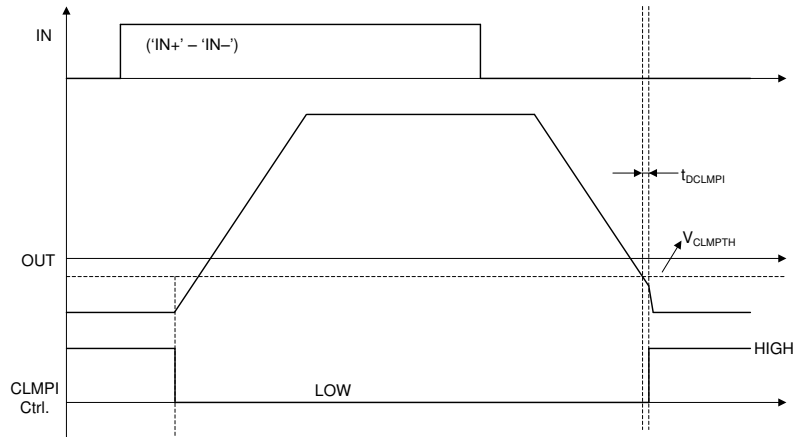
The VCC UVLO protection details are discussed in this section. 图 7-8 shows the timing diagram illustrating the definition of UVLO ON/OFF threshold, deglitch filter, response time, RDY and AIN - APWM.



图 7-8. VCC UVLO Protection Timing Diagram

7.4.2 VDD UVLO

The VDD UVLO protection details are discussed in this section. 图 7-9 shows the timing diagram illustrating the definition of UVLO ON/OFF threshold, deglitch filter, response time, RDY and AIN - APWM.

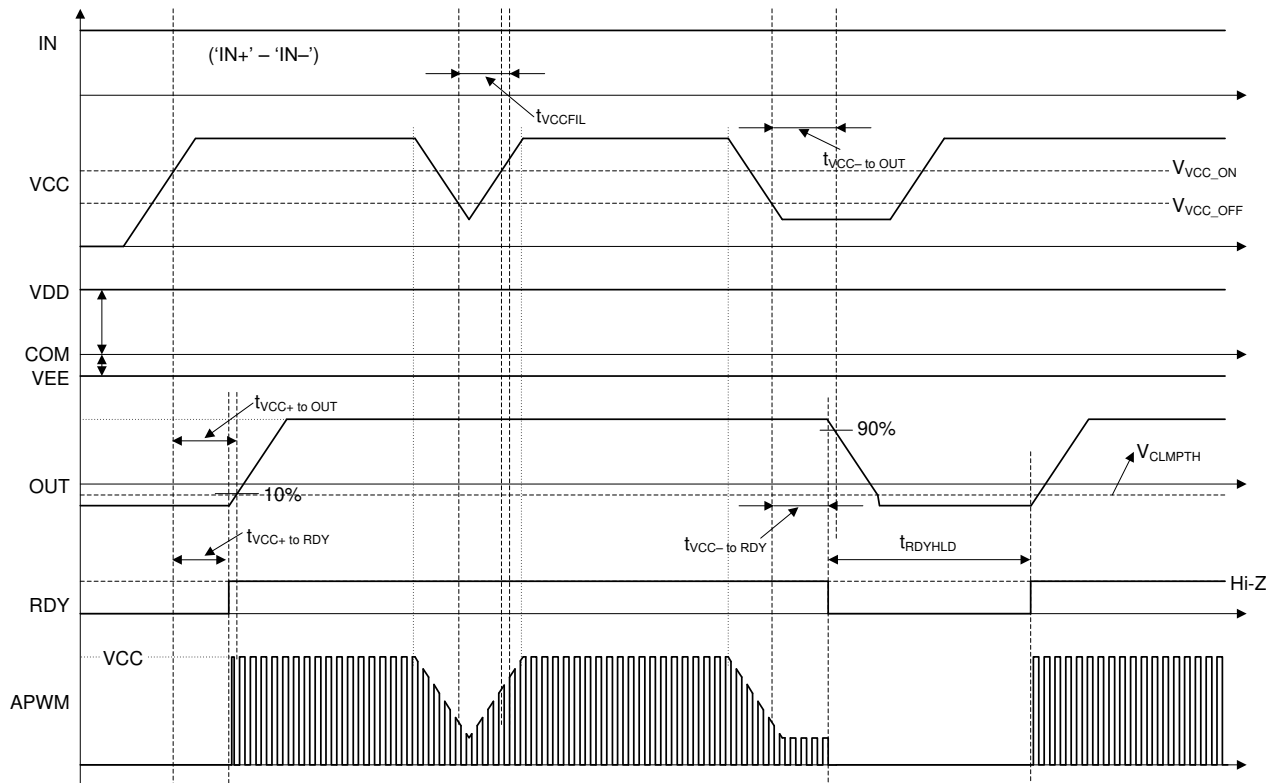

图 7-9. VDD UVLO Protection Timing Diagram

7.5 Desaturation (DESAT) Protection

7.5.1 DESAT Protection with Soft Turn-OFF

DESAT function is used to detect V_{DS} for SiC-MOSFETs or V_{CE} for IGBTs under over current conditions. 图 7-10 shows the timing diagram of DESAT operation with soft turn-off during the turning on transition.

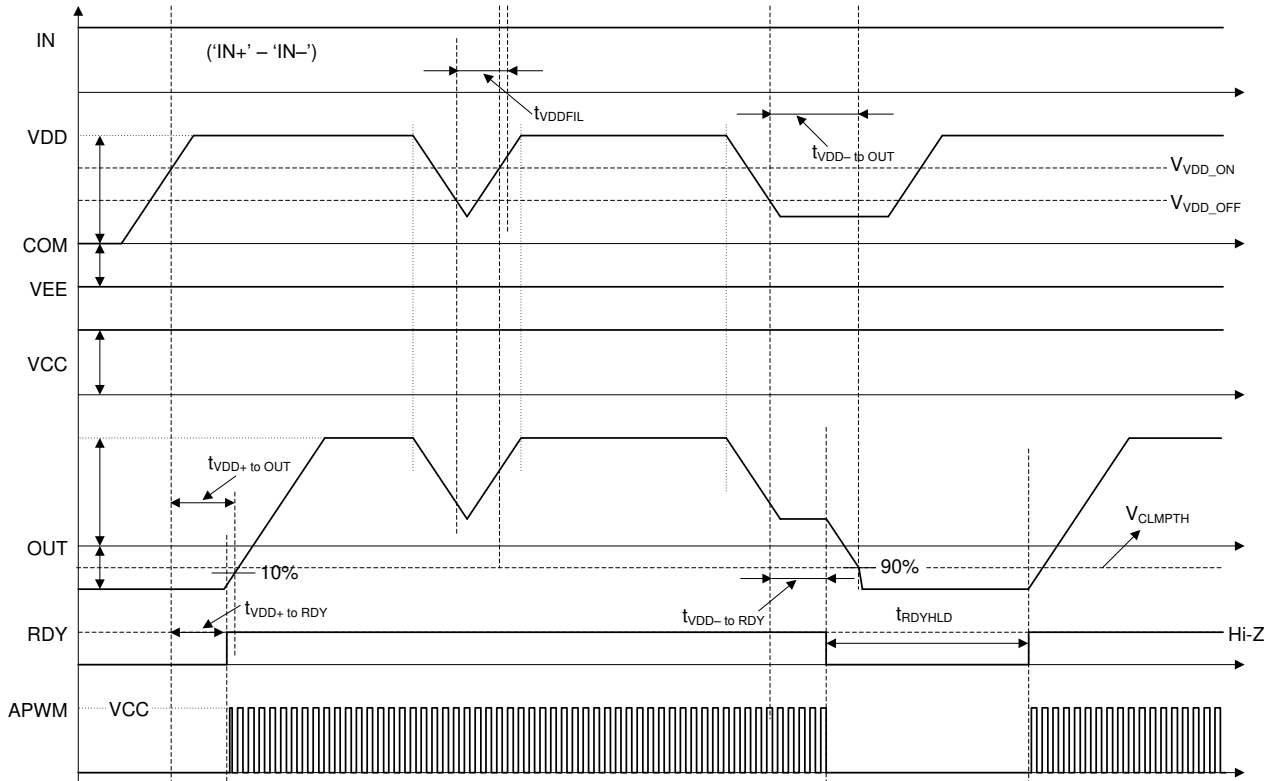

图 7-10. DESAT Protection With Soft Turn-OFF During Turn-ON Transition

图 7-11 shows the timing diagram of DESAT protection while the power device is already turned on.

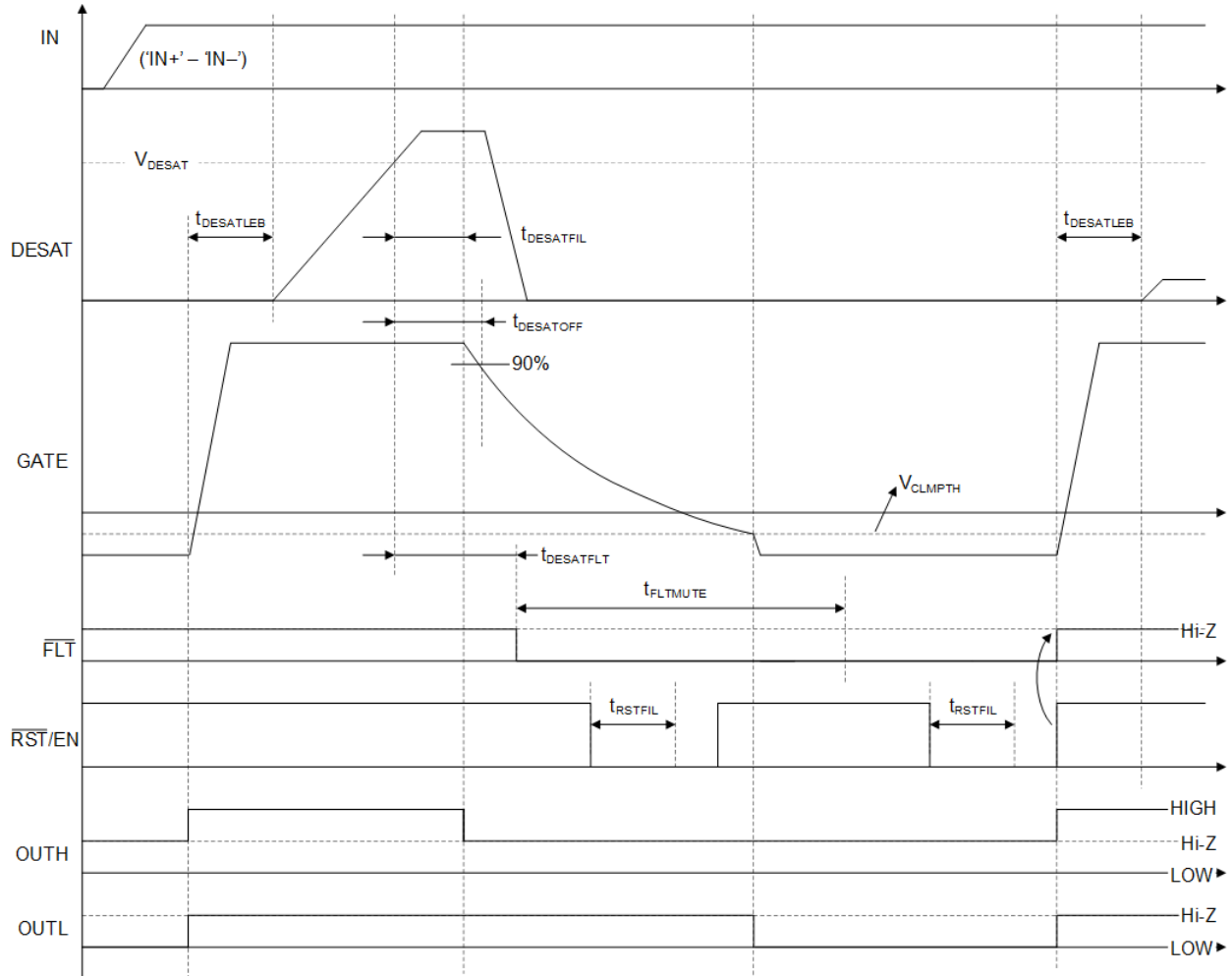

图 7-11. DESAT Protection With Soft Turn-OFF While Power Device is ON

8 Detailed Description

8.1 Overview

The UCC21750 device is an advanced isolated gate driver with state-of-art protection and sensing features for SiC MOSFETs and IGBTs. The device can support up to 2121-V DC operating voltage based on SiC MOSFETs and IGBTs, and can be used to above 10-kW applications, such as HEV/EV traction inverter, motor drive, on-board and off-board battery charger, solar inverter, and so forth. The galvanic isolation is implemented by the capacitive isolation technology, which can realize a reliable reinforced isolation between the low voltage DSP/MCU and high voltage side.

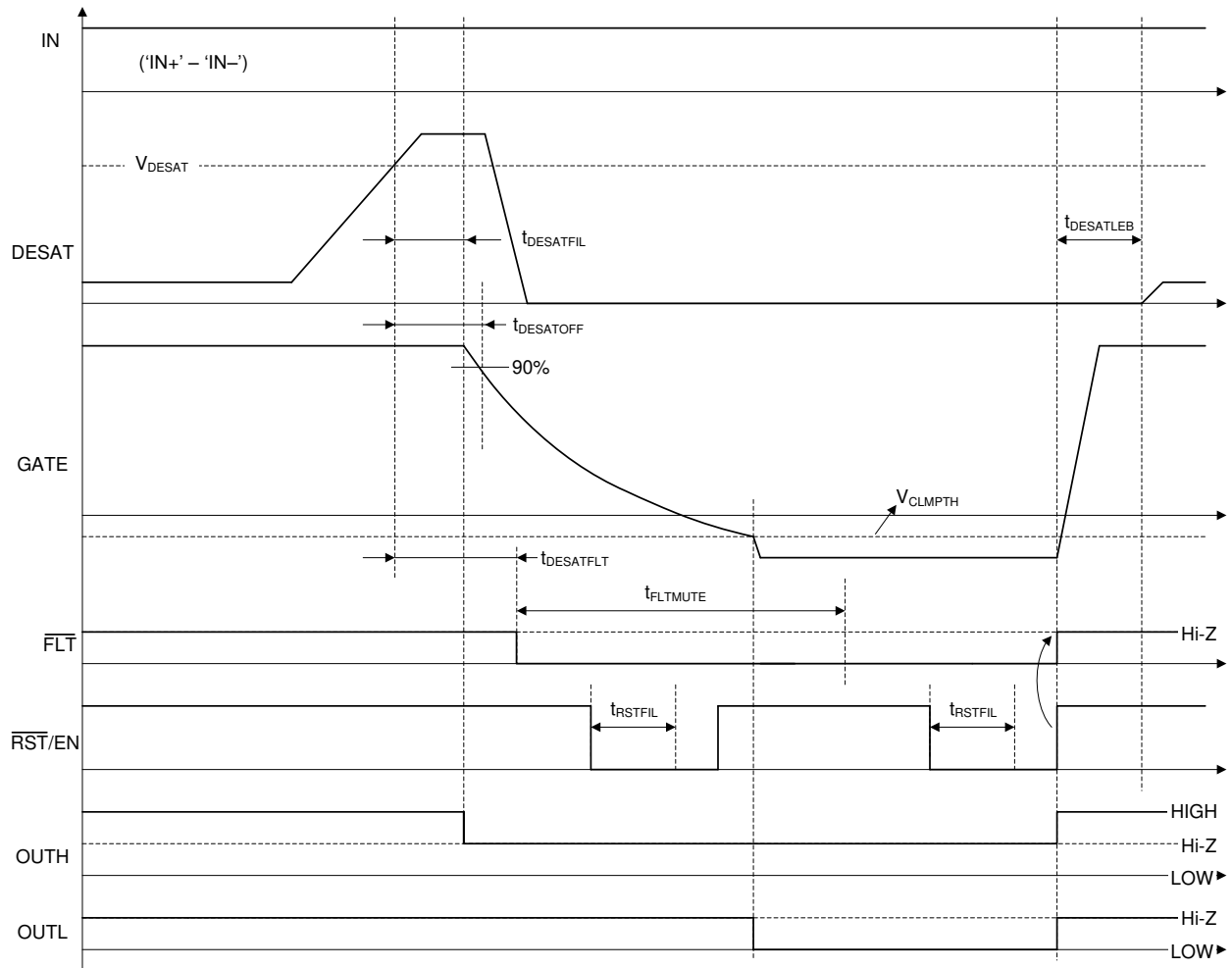
The ± 10 -A peak sink and source current of the UCC21750 can drive the SiC MOSFET modules and IGBT modules directly without an extra buffer. The driver can also be used to drive higher power modules or parallel modules with external buffer stage. The input side is isolated with the output side with a reinforced isolation barrier based on capacitive isolation technology. The device can support up to 1.5-kV_{RMS} working voltage, 12.8-kV_{PK} surge immunity with longer than 40 years isolation barrier life. The strong drive strength helps to switch the device fast and reduce the switching loss, while the 150-V/ns minimum CMTI assures the reliability of the system with fast switching speed. The small propagation delay and part-to-part skew can minimize the deadtime setting, so the conduction loss can be reduced.

The device includes extensive protection and monitor features to increase the reliability and robustness of the SiC MOSFET and IGBT based systems. The 12-V output side power supply UVLO is suitable for switches with gate voltage ≥ 15 V. The active miller clamp feature prevents the false turn on causing by miller capacitance during fast switching. The device has the state-of-art DESAT detection time and fault reporting function to the low voltage side DSP/MCU. The soft turn-off is triggered when the DESAT fault is detected, minimizing the short circuit energy while reducing the overshoot voltage on the switches.

The isolated analog to PWM sensor can be used as switch temperature sensing, DC bus voltage sensing, auxiliary power supply sensing, and so forth. The PWM signal can be fed directly to DSP/MCU or through a low-pass-filter as an analog signal.

8.2 Functional Block Diagram

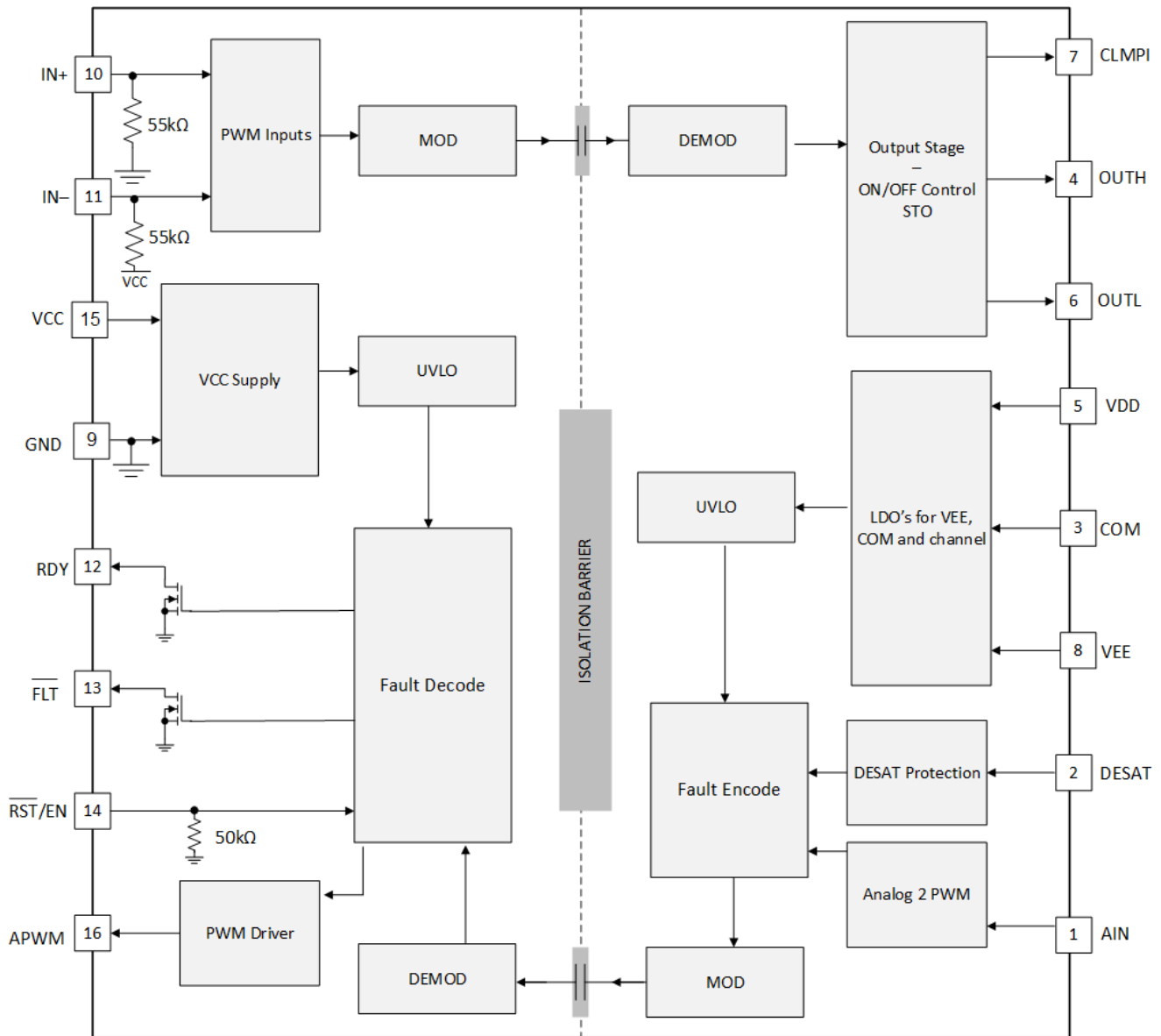

8.3 Feature Description

8.3.1 Power Supply

The input side power supply VCC can support a wide voltage range from 3 V to 5.5 V. The device supports both unipolar and bipolar power supply on the output side, with a wide range from 13 V to 33 V from VDD to VEE. The negative power supply with respect to switch source or emitter is usually adopted to avoid false turn on when the other switch in the phase leg is turned on. The negative voltage is especially important for SiC MOSFET due to its fast switching speed.

8.3.2 Driver Stage

The UCC21750 has ± 10 -A peak drive strength and is suitable for high power applications. The high drive strength can drive a SiC MOSFET module, IGBT module or paralleled discrete devices directly without extra buffer stage. The UCC21750 can also be used to drive higher power modules or parallel modules with extra buffer stage. Regardless of the values of VDD, the peak sink and source current can be kept at 10 A. The driver features an important safety function wherein, when the input pins are in floating condition, the OUTH/OUTL is held in LOW state. The split output of the driver stage is depicted in [Figure 8-1](#). The driver has rail-to-rail output by

implementing a hybrid pull-up structure with a P-Channel MOSFET in parallel with an N-Channel MOSFET, and an N-Channel MOSFET to pulldown. The pull-up NMOS is the same as the pull down NMOS, so the on-resistance R_{NMOS} is the same as R_{OL} . The hybrid pull-up structure delivers the highest peak-source current when it is most needed, during the miller plateau region of the power semiconductor turn-on transient. The R_{OH} in 图 8-1 represents the on-resistance of the pull-up P-Channel MOSFET. However, the effective pull-up resistance is much smaller than R_{OH} . Because the pull-up N-Channel MOSFET has much smaller on-resistance than the P-Channel MOSFET, the pull-up N-Channel MOSFET dominates most of the turn-on transient, until the voltage on OUTH pin is about 3 V below VDD voltage. The effective resistance of the hybrid pull-up structure during this period is about $2 \times R_{OL}$. Then the P-Channel MOSFET pulls up the OUTH voltage to VDD rail. The low pull-up impedance results in strong drive strength during the turn-on transient, which shortens the charging time of the input capacitance of the power semiconductor and reduces the turn on switching loss.

The pull-down structure of the driver stage is implemented solely by a pull-down N-Channel MOSFET. This MOSFET can ensure the OUTL voltage be pulled down to VEE rail. The low pull-down impedance not only results in high sink current to reduce the turn-off time, but also helps to increase the noise immunity considering the miller effect.



图 8-1. Gate Driver Output Stage

8.3.3 VCC and VDD Undervoltage Lockout (UVLO)

The UCC21750 implements the internal UVLO protection feature for both input and output power supplies VCC and VDD. When the supply voltage is lower than the threshold voltage, the driver output is held as LOW. The output only goes HIGH when both VCC and VDD are out of the UVLO status. The UVLO protection feature not only reduces the power consumption of the driver itself during low power supply voltage condition, but also increases the efficiency of the power stage. For SiC MOSFET and IGBT, the on-resistance reduces while the gate-source voltage or gate-emitter voltage increases. If the power semiconductor is turned on with a low VDD value, the conduction loss increases significantly and can lead to a thermal issue and efficiency reduction of the power stage. The UCC21750 implements a 12-V threshold voltage of VDD UVLO, with 800-mV hysteresis. This threshold voltage is suitable for both SiC MOSFET and IGBT.

The UVLO protection block features with hysteresis and deglitch filter, which help to improve the noise immunity of the power supply. During the turn-on and turn-off switching transient, the driver sources and sinks a peak transient current from the power supply, which can result in sudden voltage drop of the power supply. With

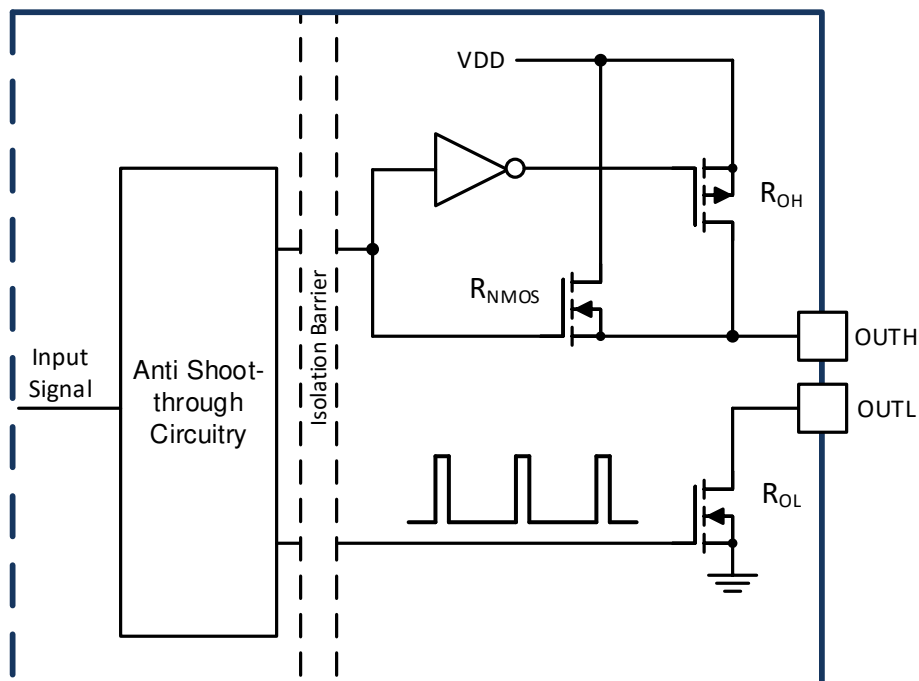
hysteresis and UVLO deglitch filter, the internal UVLO protection block ignores small noises during the normal switching transients.

The timing diagrams of the UVLO feature of VCC and VDD are shown in 图 7-8, and 图 7-9. The RDY pin on the input side is used to indicate the power good condition. The RDY pin is open drain. During UVLO condition, the RDY pin is held in low status and connected to GND. Normally the pin is pulled up externally to VCC to indicate the power good. The AIN-APWM function stops working during the UVLO status. The APWM pin on the input side is held LOW.

8.3.4 Active Pulldown

The UCC21750 implements an active pulldown feature to ensure the OUTH/OUTL pin clamping to VEE when the VDD is open. The OUTH/OUTL pin is in high-impedance status when VDD is open, the active pulldown feature can prevent the output be false turned on before the device is back to control.



图 8-2. Active Pulldown

8.3.5 Short Circuit Clamping

During short circuit condition, the miller capacitance can cause a current sinking to the OUTH/OUTL/CLMPI pin due to the high dV/dt and boost the OUTH/OUTL/CLMPI voltage. The short circuit clamping feature of the UCC21750 can clamp the OUTH/OUTL/CLMPI pin voltage to be slightly higher than VDD, which can protect the power semiconductors from a gate-source and gate-emitter overvoltage breakdown. This feature is realized by an internal diode from the OUTH/OUTL/CLMPI to VDD.

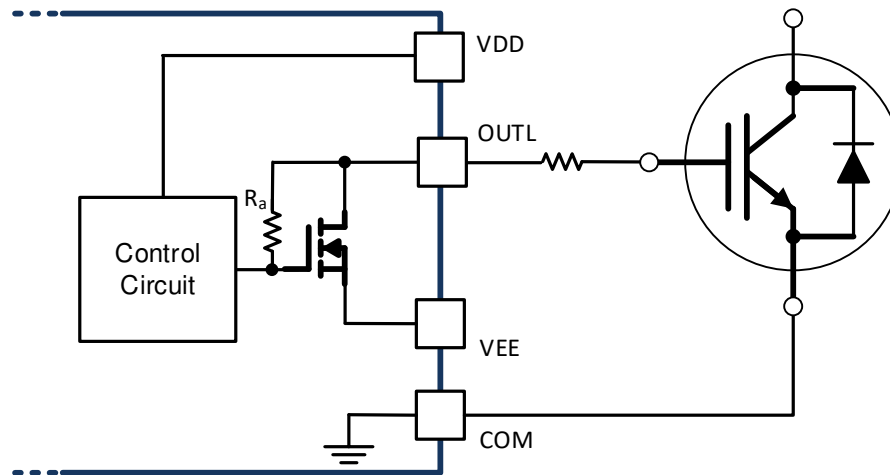

图 8-3. Short Circuit Clamping

8.3.6 Internal Active Miller Clamp

Active miller clamp feature is important to prevent the false turn-on while the driver is in OFF state. In applications which the device can be in synchronous rectifier mode, the body diode conducts the current during the deadtime while the device is in OFF state, the drain-source or collector-emitter voltage remains the same and the dV/dt happens when the other power semiconductor of the phase leg turns on. The low internal pull-down impedance of the UCC21750 can provide a strong pulldown to hold the OUTL to VEE. However, external gate resistance is usually adopted to limit the dV/dt . The miller effect during the turn on transient of the other power semiconductor can cause a voltage drop on the external gate resistor, which boost the gate-source or gate-emitter voltage. If the voltage on V_{GS} or V_{GE} is higher than the threshold voltage of the power semiconductor, a shoot through can happen and cause catastrophic damage. The active miller clamp feature of the UCC21750 drives an internal MOSFET, which connects to the device gate. The MOSFET is triggered when the gate voltage is lower than V_{CLMPH} , which is 2 V above VEE, and creates a low impedance path to avoid the false turn on issue.

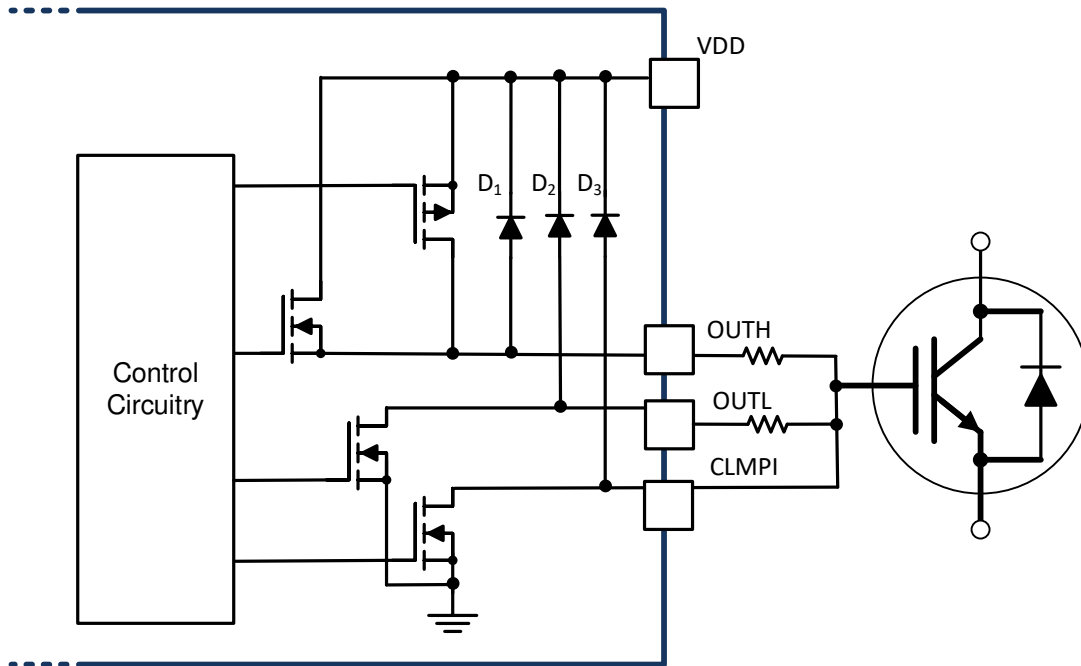

图 8-4. Active Miller Clamp

8.3.7 Desaturation (DESAT) Protection

The UCC21750 implements a fast overcurrent and short circuit protection feature to protect the IGBT module from catastrophic breakdown during fault. The DESAT pin of the device has a typical 9-V threshold with respect to COM, source or emitter of the power semiconductor. When the input is in floating condition, or the output is held in low state, the DESAT pin is pulled down by an internal MOSFET and held in LOW state, which prevents the overcurrent and short circuit fault from false triggering. The internal current source of the DESAT pin is activated only during the driver ON state, which means the overcurrent and short circuit protection feature only works when the power semiconductor is in on state. The internal pulldown MOSFET helps to discharge the voltage of DESAT pin when the power semiconductor is turned off. The UCC21750 features a 200-ns internal leading edge blanking time after the OUTH switches to high state. The internal current source is activated to charge the external blanking capacitor after the internal leading edge blanking time. The typical value of the internal current source is 500 μ A.

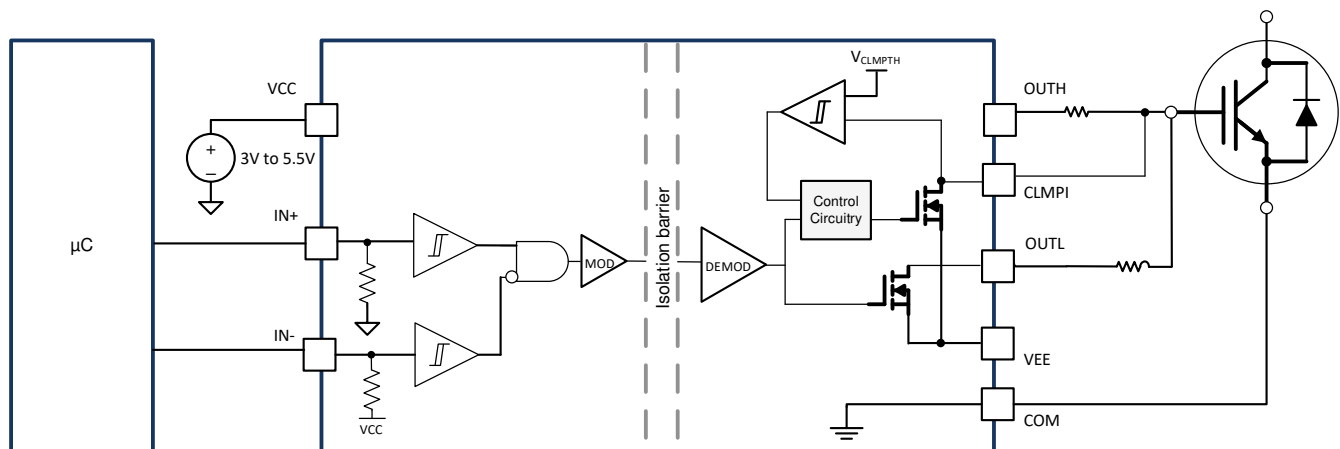

图 8-5. DESAT Protection

8.3.8 Soft Turn-Off

The UCC21750 initiates a soft turn-off when the overcurrent and short circuit protection is triggered. When the overcurrent and short circuit fault happens, the IGBT transits from the active region to the desaturation region very fast. The channel current is controlled by the gate voltage and decreasing in a soft manner, thus the overshoot of the IGBT is limited and prevents the overvoltage breakdown. There is a tradeoff between the overshoot voltage and short circuit energy. The turn off speed must be slow to limit the overshoot voltage, but the shutdown time must not be too long that the large energy dissipation can breakdown the device. The 400-mA soft turn-off current of the UCC21750 makes sure the power switches is safely turned off during short circuit events. The timing diagram of soft turn-off shows in 图 7-10.

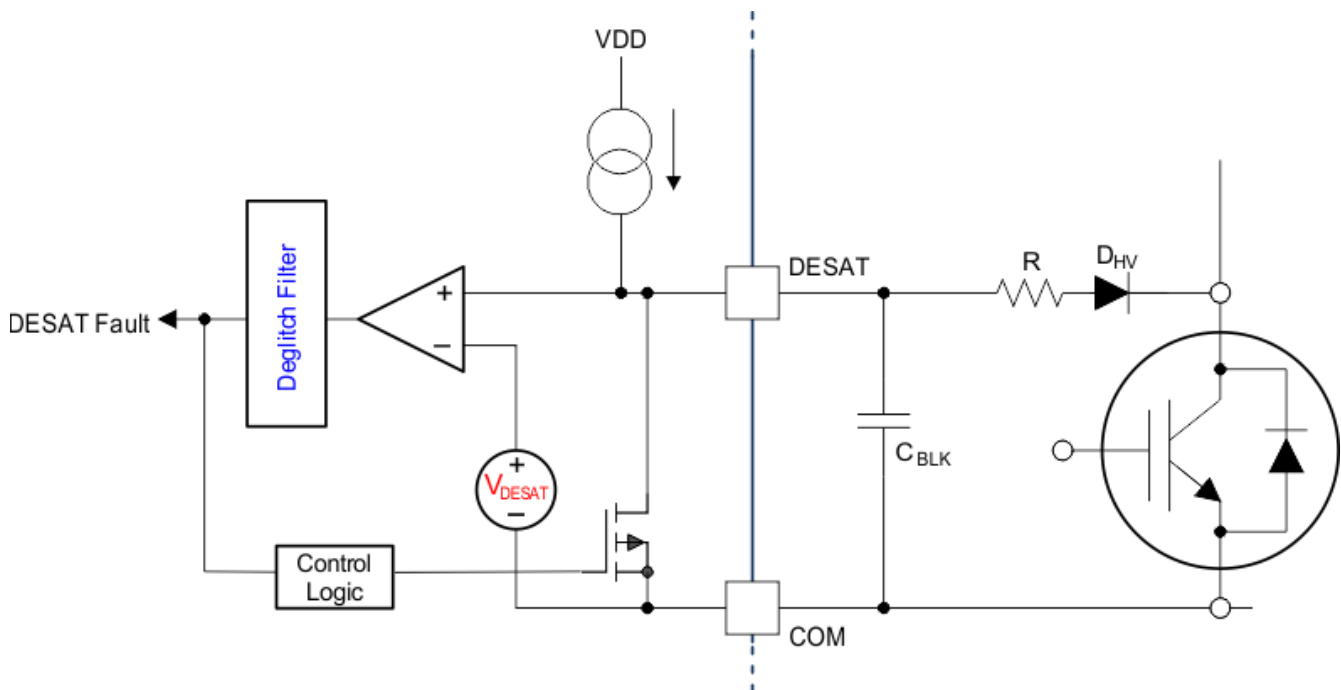

图 8-6. Soft Turn-Off

8.3.9 Fault ($\overline{\text{FLT}}$, Reset, and Enable ($\overline{\text{RST/EN}}$))

The $\overline{\text{FLT}}$ pin of the UCC21750 is open drain and can report a fault signal to the DSP/MCU when the fault is detected through the DESAT pin. The $\overline{\text{FLT}}$ pin is pulled down to GND after the fault is detected, and is held low until a reset signal is received from $\overline{\text{RST/EN}}$. The device has a fault mute time t_{FLTMUTE} , within which the device ignores any reset signal.

The $\overline{\text{RST/EN}}$ is pulled down internally by a 50-k Ω resistor, and is thus disabled by default when this pin is floating. Pull up externally to enable the driver. The pin has two purposes:

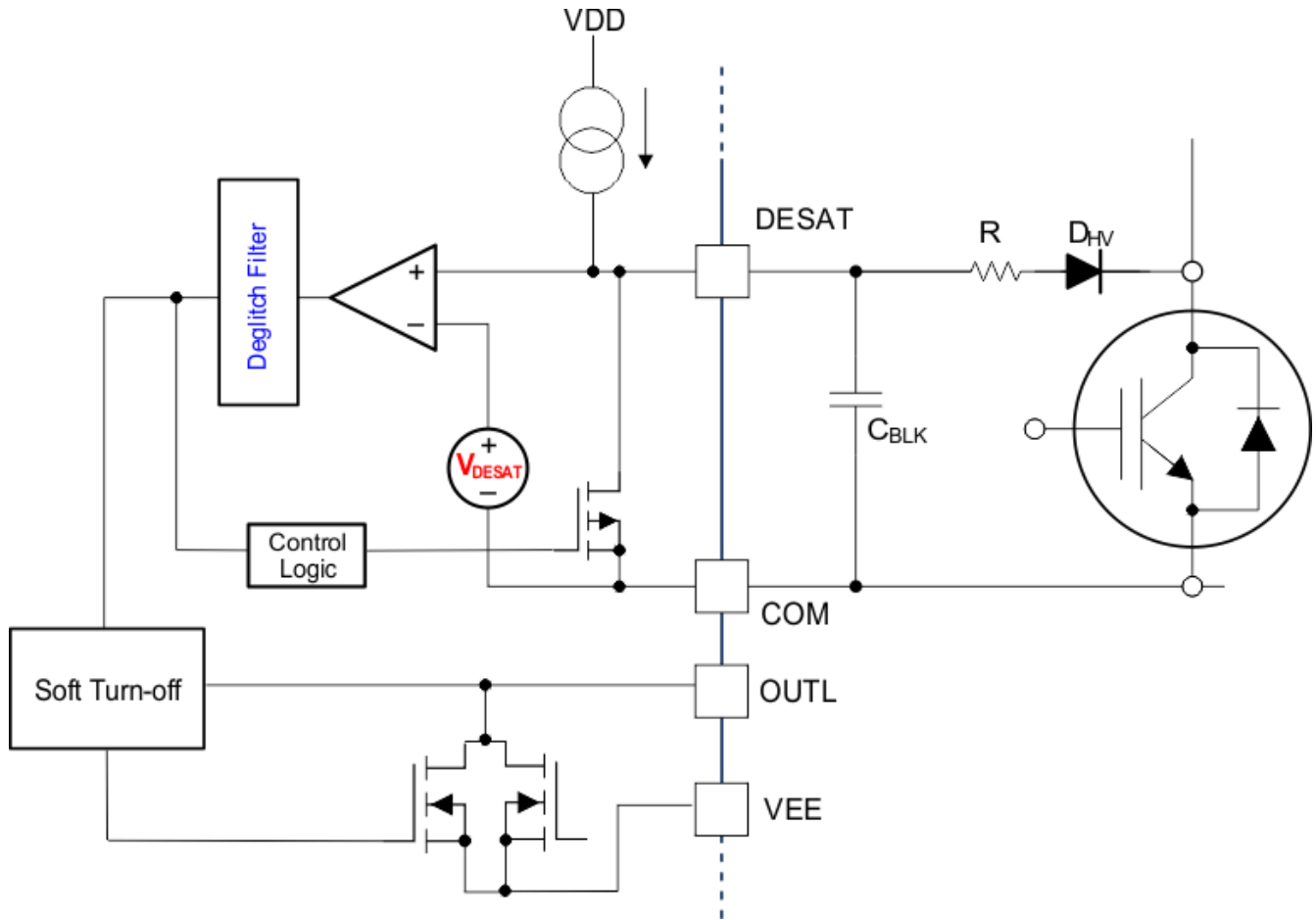
- To reset the $\overline{\text{FLT}}$ pin: to reset, then $\overline{\text{RST/EN}}$ pin is pulled low; if the pin is set and held in low state for more than t_{RSTFIL} after the mute time t_{FLTMUTE} , then the fault signal is reset and $\overline{\text{FLT}}$ is reset back to the high impedance status at the rising edge of the input signal at $\overline{\text{RST/EN}}$ pin.
- Enable and shutdown the device: if the $\overline{\text{RST/EN}}$ pin is pulled low for longer than t_{RSTFIL} , the driver disables and OUTL is activated to pull down the gate of the IGBT or SiC MOSFET. The pin must be pulled up externally to enable the part, otherwise the device is disabled by default.

8.3.10 Isolated Analog to PWM Signal Function

The UCC21750 features an isolated analog to PWM signal function from AIN to APWM pin, which allows the isolated temperature sensing, high voltage dc bus voltage sensing, and so forth. An internal current source I_{AIN} in AIN pin is implemented in the device to bias an external thermal diode or temperature sensing resistor. The UCC21750 encodes the voltage signal V_{AIN} to a PWM signal, passing through the reinforced isolation barrier, and output to APWM pin on the input side. The PWM signal can either be transferred directly to DSP/MCU to calculate the duty cycle, or filtered by a simple RC filter as an analog signal. The AIN voltage input range is from 0.6 V to 4.5 V, and the corresponding duty cycle of the APWM output ranges from 88% to 10%. The duty cycle

increases linearly from 10% to 88% while the AIN voltage decreases from 4.5 V to 0.6 V. This action corresponds to the temperature coefficient of the negative temperature coefficient (NTC) resistor and thermal diode. When AIN is floating, the AIN voltage is 5 V and the APWM operates at 400 kHz with approximately 10% duty cycle. The accuracy of the duty cycle is $\pm 3\%$ across temperature without one time calibration. The accuracy can be improved using calibration. The accuracy of the internal current source I_{AIN} is $\pm 3\%$ across temperature.

The isolated analog to PWM signal feature can also support other analog signal sensing, such as the high voltage dc bus voltage, and so forth. The internal current source I_{AIN} must be taken into account when designing the potential divider if sensing a high voltage.



图 8-7. Isolated Analog to PWM Signal

8.4 Device Functional Modes

The 表 8-1 lists the device function.

表 8-1. Function Table

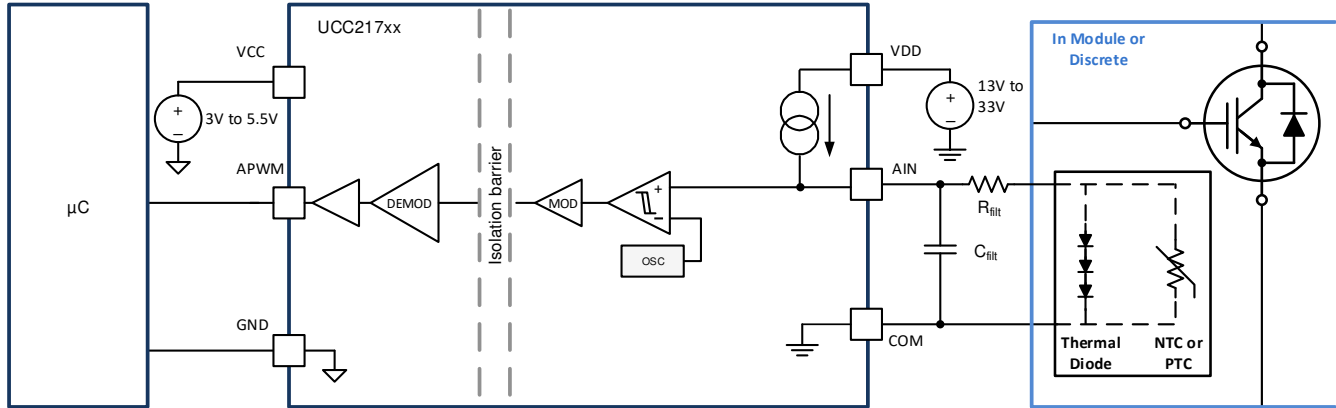
INPUT							OUTPUT				
VCC	VDD	VEE	IN+	IN-	RST/EN	AIN	RDY	FLT	OUTH/ OUTL	CLMPI	APWM
PU	PD	PU	X	X	X	X	Low	HiZ	Low	Low	Low
PD	PU	PU	X	X	X	X	Low	HiZ	Low	Low	Low
PU	PU	PU	X	X	Low	X	HiZ	HiZ	Low	Low	Low
PU	Open	PU	X	X	X	X	Low	HiZ	HiZ	HiZ	HiZ
PU	PU	Open	X	X	X	X	Low	HiZ	Low	Low	Low
PU	PU	PU	Low	X	High	X	HiZ	HiZ	Low	Low	P*
PU	PU	PU	X	High	High	X	HiZ	HiZ	Low	Low	P*
PU	PU	PU	High	High	High	X	HiZ	HiZ	Low	Low	P*
PU	PU	PU	High	Low	High	X	HiZ	HiZ	High	HiZ	P*

PU: Power Up ($VCC \geq 2.85\text{ V}$, $VDD \geq 13.1\text{ V}$, $VEE \leq 0\text{ V}$); PD: Power Down ($VCC \leq 2.35\text{ V}$, $VDD \leq 9.9\text{ V}$); X: Irrelevant; P*: PWM Pulse; HiZ: High Impedance

9 Applications and Implementation

备注

以下应用部分中的信息不属于 TI 器件规格的范围，TI 不担保其准确性和完整性。TI 的客户应负责确定器件是否适用于其应用。客户应验证并测试其设计，以确保系统功能。

9.1 Application Information

The UCC21750 device is very versatile because of the strong drive strength, wide range of output power supply, high isolation ratings, high CMTI and superior protection and sensing features. The 1.5-kVRMS working voltage and 12.8-kVPK surge immunity can support up both SiC MOSFET and IGBT modules with DC bus voltage up to 2121 V. The device can be used in both low power and high power applications such as the traction inverter in HEV/EV, on-board charger and charging pile, motor driver, solar inverter, industrial power supplies and so forth. The device can drive the high power SiC MOSFET module, IGBT module or paralleled discrete device directly without external buffer drive circuit based on NPN/PNP bipolar transistor in totem-pole structure, which allows the driver to have more control to the power semiconductor and saves the cost and space of the board design. The UCC21750 can also be used to drive very high power modules or paralleled modules with external buffer stage. The input side can support power supply and microcontroller signal from 3.3 V to 5 V, and the device level shifts the signal to output side through reinforced isolation barrier. The device has wide output power supply range from 13 V to 33 V and support wide range of negative power supply. This feature allows the driver to be used in SiC MOSFET applications, IGBT application and many others. The 12-V UVLO benefits the power semiconductor with lower conduction loss and improves the system efficiency. As a reinforced isolated single channel driver, the device can be used to drive either a low-side or high-side driver.

The UCC21750 device features extensive protection and monitoring features, which can monitor, report and protect the system from various fault conditions.

- Fast detection and protection for the overcurrent and short circuit fault. The semiconductor is shutdown when the fault is detected and FLT pin is pulled down to indicate the fault detection. The device is latched unless reset signal is received from the RST/EN pin.
- Soft turn-off feature to protect the power semiconductor from catastrophic breakdown during overcurrent and short circuit fault. The shutdown energy can be controlled while the overshoot of the power semiconductor is limited.
- UVLO detection to protect the semiconductor from excessive conduction loss. After the device is detected to be in UVLO mode, the output is pulled down and RDY pin indicates the power supply is lost. The device is back to normal operation mode after the power supply is out of the UVLO status. The power good status can be monitored from the RDY pin.
- Analog signal sensing with isolated analog to PWM signal feature. This feature allows the device to sense the temperature of the semiconductor from the thermal diode or temperature sensing resistor, or dc bus voltage with resistor divider. A PWM signal is generated on the low voltage side with reinforced isolated from the high voltage side. The signal can be fed back to the microcontroller for the temperature monitoring, voltage monitoring and so forth.
- The active miller clamp feature protects the power semiconductor from false turn on.
- Enable and disable function through the RST/EN pin.
- Short circuit clamping.
- Active pulldown.

9.2 Typical Application

图 9-1 shows the typical application of a half bridge using two UCC21750 isolated gate drivers. The half bridge is a basic element in various power electronics applications such as in motor drive applications to control the operating speed and torque of an AC motor.



图 9-1. Typical Application Schematic

9.2.1 Design Requirements

The design of the power system for end equipment must consider some design requirements to ensure the reliable operation of the UCC21750 through the load range. The design considerations include the peak source and sink current, power dissipation, overcurrent and short circuit protection, AIN-APWM function for analog signal sensing and so forth.

A design example for a half bridge based on IGBT is given in this subsection. 表 9-1 shows the design parameters.

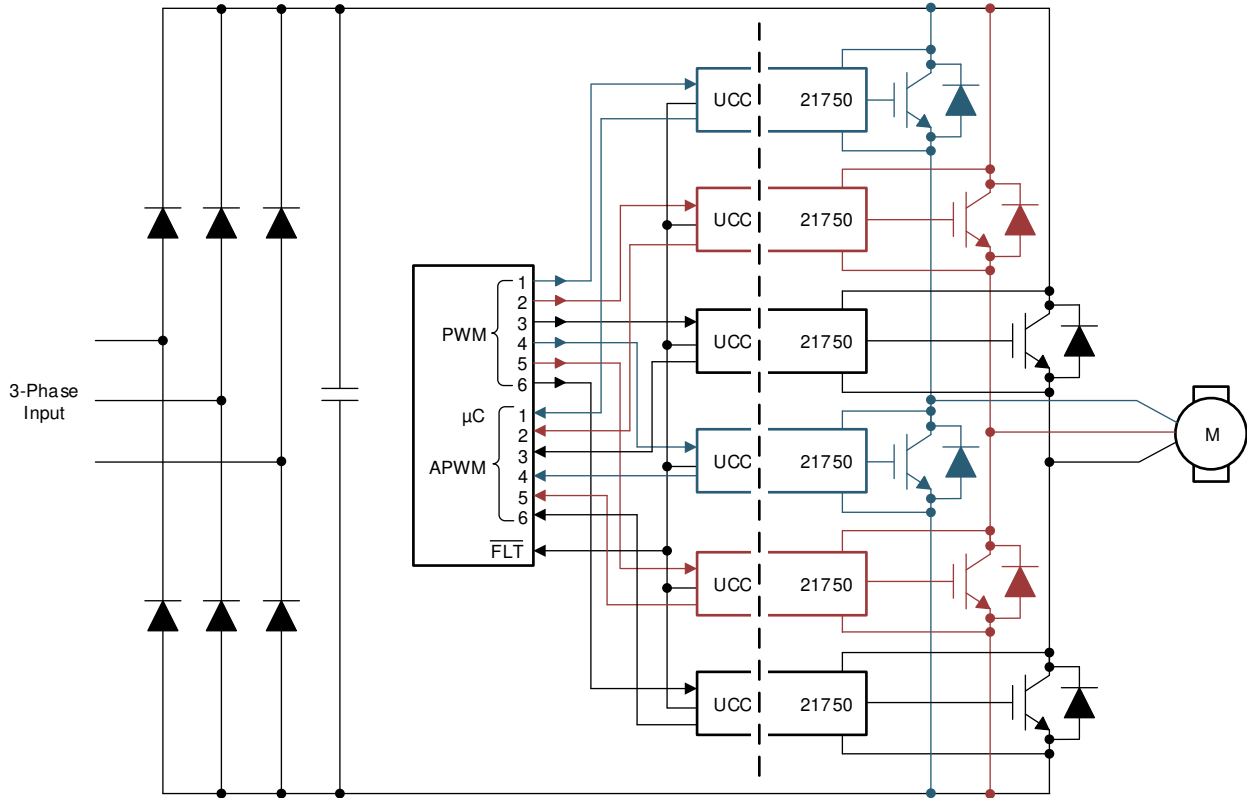
表 9-1. Design Parameters

PARAMETER	VALUE
Input supply voltage	5 V
IN-OUT configuration	Non-inverting
Positive output voltage VDD	15 V
Negative output voltage VEE	- 5 V
DC bus voltage	800 V
Peak drain current	300 A
Switching frequency	50 kHz
Switch type	IGBT module

9.2.2 Detailed Design Procedure

9.2.2.1 Input Filters for IN+, IN -, and RST/EN

In the applications of traction inverter or motor drive, the power semiconductors are in hard switching mode. With the strong drive strength of the UCC21750, the dV/dt can be high, especially for SiC MOSFET. Noise cannot

only be coupled to the gate voltage due to the parasitic inductance, but also to the input side as the non-ideal PCB layout and coupled capacitance.

The UCC21750 features a 40-ns internal deglitch filter to IN+, IN- and $\overline{\text{RST/EN}}$ pin. Any signal less than 40 ns can be filtered out from the input pins. For noisy systems, external low-pass filter can be added externally to the input pins. Adding low-pass filters to IN+, IN- and $\overline{\text{RST/EN}}$ pins can effectively increase the noise immunity and increase the signal integrity. When not in use, the IN+, IN- and $\overline{\text{RST/EN}}$ pins must not be floating. IN- must be tied to GND if only IN+ is used for non-inverting input to output configuration. The purpose of the low-pass filter is to filter out the high frequency noise generated by the layout parasitics. While choosing the low-pass filter resistors and capacitors, both the noise immunity effect and delay time must be considered according to the system requirements.

9.2.2.2 PWM Interlock of IN+ and IN-

The UCC21750 features the PWM interlock for IN+ and IN- pins, which can be used to prevent the phase leg shoot through issue. As shown in 表 8-1, the output is logic low while both IN+ and IN- are logic high. When only IN+ is used, IN- can be tied to GND. To use the PWM interlock function, the PWM signal of the other switch in the phase leg can be sent to the IN- pin. As shown in 图 9-2, the PWM_T is the PWM signal to top side switch, the PWM_B is the PWM signal to bottom side switch. For the top side gate driver, the PWM_T signal is given to the IN+ pin, while the PWM_B signal is given to the IN- pin; for the bottom side gate driver, the PWM_B signal is given to the IN+ pin, while PWM_T signal is given to the IN- pin. When both PWM_T and PWM_B signals are high, the outputs of both gate drivers are logic low to prevent the shoot through condition.



图 9-2. PWM Interlock for a Half Bridge

9.2.2.3 $\overline{\text{FLT}}$, RDY, and $\overline{\text{RST/EN}}$ Pin Circuitry

Both $\overline{\text{FLT}}$ and RDY pin are open-drain output. The $\overline{\text{RST/EN}}$ pin has a 50-k Ω internal pulldown resistor, so the driver is in OFF status if the $\overline{\text{RST/EN}}$ pin is not pulled up externally. A 5 k Ω resistor can be used as pullup resistor for the $\overline{\text{FLT}}$, RDY and $\overline{\text{RST/EN}}$ pins.

To improve the noise immunity due to the parasitic coupling and common mode noise, low pass filters can be added between the $\overline{\text{FLT}}$, RDY and $\overline{\text{RST/EN}}$ pins and the microcontroller. A filter capacitor between 100 pF to 300 pF can be added.

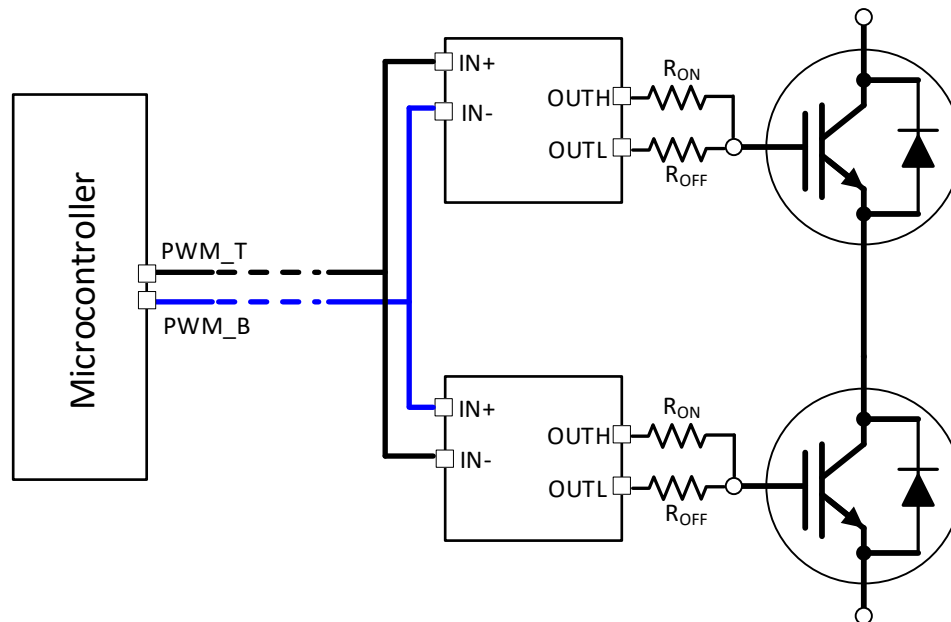

图 9-3. $\overline{\text{FLT}}$, RDY , and $\overline{\text{RST/EN}}$ Pins Circuitry

9.2.2.4 $\overline{\text{RST/EN}}$ Pin Control

The $\overline{\text{RST/EN}}$ pin has two functions. The pin is used to enable or shutdown the outputs of the driver and to reset the fault signaled on the $\overline{\text{FLT}}$ pin after DESAT is detected. $\overline{\text{RST/EN}}$ pin must to be pulled up to enable the device; when the pin is pulled down, the device is in disabled status. By default the driver is disabled with the internal $50\text{k}\Omega$ pulldown resistor at this pin.

When the driver is latched after DESAT is detected, the $\overline{\text{FLT}}$ pin and output are latched low and must be reset by the $\overline{\text{RST/EN}}$ pin. The microcontroller must send a signal to $\overline{\text{RST/EN}}$ pin after the fault to reset the driver. The driver does not respond until after the mute time t_{FLTMUTE} . The reset signal must be held low for at least t_{RSTFIL} after the mute time.

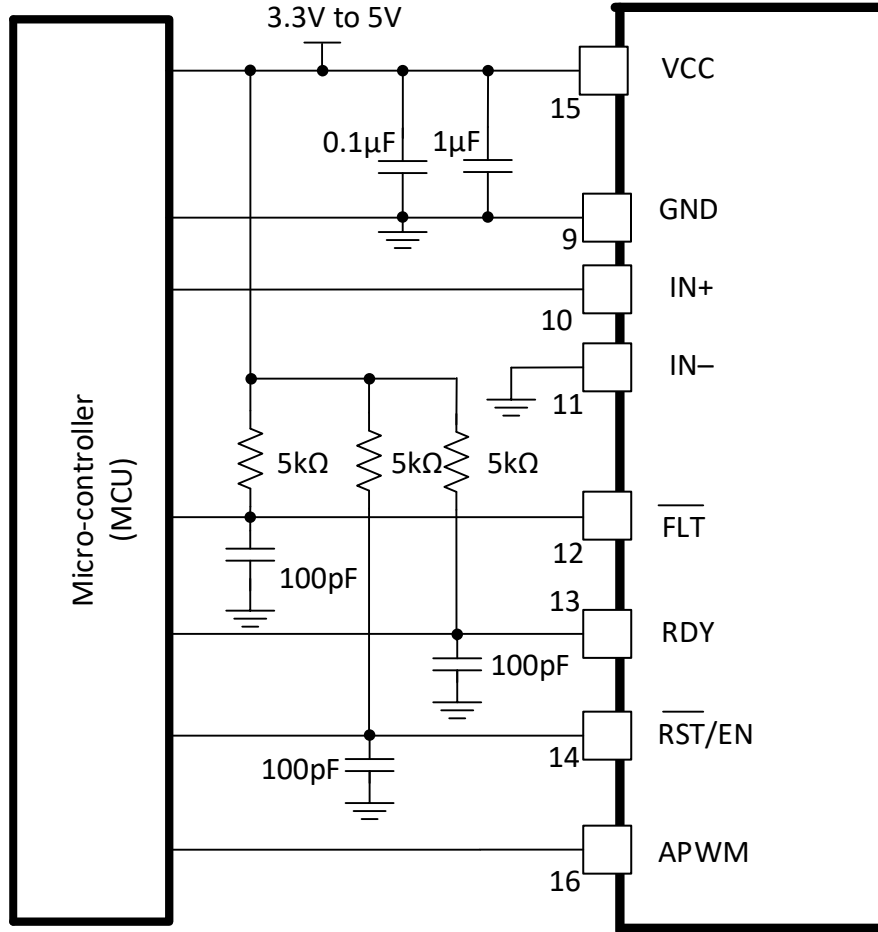
This pin can also be used to automatically reset the driver. The continuous input signal IN+ or IN- can be applied to $\overline{\text{RST/EN}}$ pin. There is no separate reset signal from the microcontroller when configuring the driver this way. If the PWM is applied to the non-inverting input IN+ , then IN+ can also be tied to $\overline{\text{RST/EN}}$ pin. If the PWM is applied to the inverting input IN- , then a NOT logic is needed between the PWM signal from the microcontroller and the $\overline{\text{RST/EN}}$ pin. Using either configuration results in the driver being reset in every switching cycle without an extra control signal from microcontroller tied to $\overline{\text{RST/EN}}$ pin. One must ensure the PWM off-time is greater than t_{RSTFIL} in order to reset the driver in cause of a DESAT fault.



图 9-4. Automatic Reset Control

9.2.2.5 Turn-On and Turn-Off Gate Resistors

The UCC21750 features split outputs OUTH and OUTL, which enables the independent control of the turn on and turn off switching speed. The turn on and turn off resistance determine the peak source and sink current, which controls the switching speed in turn. Meanwhile, the power dissipation in the gate driver must be considered to ensure the device is in the thermal limit. At first, the peak source and sink current are calculated as:

$$I_{\text{source_pk}} = \min\left(10\text{A}, \frac{V_{\text{DD}} - V_{\text{EE}}}{R_{\text{OH_EFF}} + R_{\text{ON}} + R_{\text{G_Int}}}\right)$$

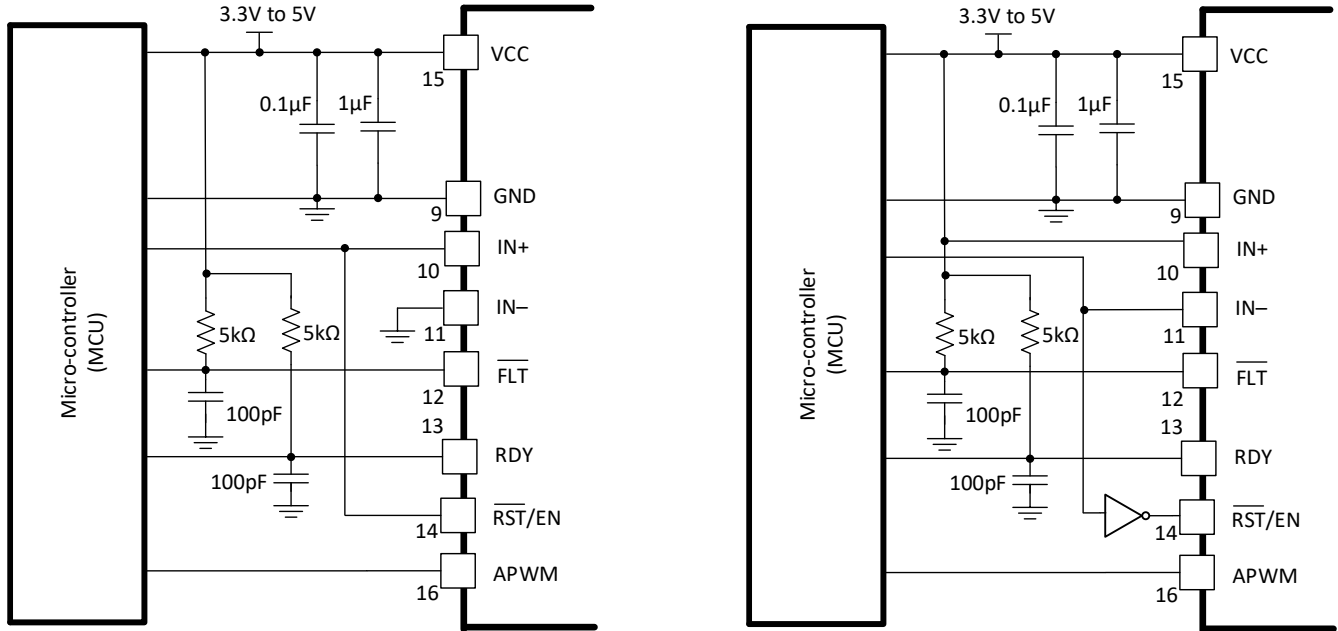
$$I_{\text{sink_pk}} = \min\left(10\text{A}, \frac{V_{\text{DD}} - V_{\text{EE}}}{R_{\text{OL}} + R_{\text{OFF}} + R_{\text{G_Int}}}\right) \quad (1)$$

Where

- $R_{\text{OH_EFF}}$ is the effective internal pull up resistance of the hybrid pull-up structure, shown in 图 8-1, which is approximately $2 \times R_{\text{OL}}$, about 0.7Ω . This is the dominant resistance during the switching transient of the pull up structure.
- R_{OL} is the internal pulldown resistance, about 0.3Ω .
- R_{ON} is the external turn on gate resistance.
- R_{OFF} is the external turn off gate resistance.
- $R_{\text{G_Int}}$ is the internal resistance of the SiC MOSFET or IGBT module.



图 9-5. Output Model for Calculating Peak Gate Current

For example, for an IGBT module based system with the following parameters:

- $Q_g = 3300 \text{ nC}$
- $R_{G_Int} = 1.7 \text{ } \Omega$
- $R_{ON} = R_{OFF} = 1 \text{ } \Omega$

The peak source and sink current in this case are:

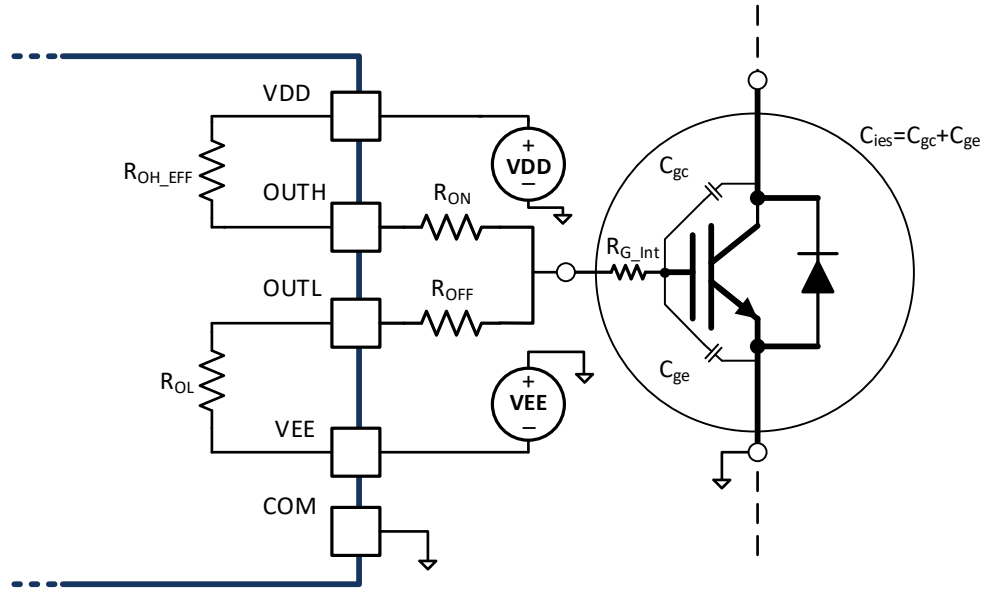
$$I_{\text{source_pk}} = \min\left(10\text{A}, \frac{V_{DD} - V_{EE}}{R_{OH_EFF} + R_{ON} + R_{G_Int}}\right) \approx 5.9\text{A}$$

$$I_{\text{sink_pk}} = \min\left(10\text{A}, \frac{V_{DD} - V_{EE}}{R_{OL} + R_{OFF} + R_{G_Int}}\right) \approx 6.7\text{A} \quad (2)$$

Thus, by using a 1- Ω external gate resistance, the peak source current is 5.9 A, the peak sink current is 6.7 A. The collector-to-emitter dV/dt during the turn on switching transient is dominated by the gate current at the miller plateau voltage. The hybrid pullup structure ensures the peak source current at the miller plateau voltage, unless the turn on gate resistor is too high. The faster the collector-to-emitter, V_{ce} , voltage rises to V_{DC} , the smaller the turn on switching loss is. The dV/dt can be estimated as $Q_g/I_{\text{source_pk}}$. For the turn off switching transient, the drain-to-source dV/dt is dominated by the load current, unless the turn off gate resistor is too high. After V_{ce} reaches the dc bus voltage, the power semiconductor is in saturation mode and the channel current is controlled by V_{ge} . The peak sink current determines the dI/dt , which dominates the V_{ce} voltage overshoot accordingly. If using relatively large turn off gate resistance, the V_{ce} overshoot can be limited. The overshoot can be estimated by:

$$\Delta V_{ce} = L_{\text{stray}} \cdot I_{\text{load}} / ((R_{OFF} + R_{OL} + R_{G_Int}) \cdot C_{ies} \cdot \ln(V_{\text{plat}} / V_{th})) \quad (3)$$

Where

- L_{stray} is the stray inductance in power switching loop, as shown in 图 9-6
- I_{load} is the load current, which is the turn off current of the power semiconductor
- C_{ies} is the input capacitance of the power semiconductor
- V_{plat} is the plateau voltage of the power semiconductor
- V_{th} is the threshold voltage of the power semiconductor



图 9-6. Stray Parasitic Inductance of IGBTs in a Half-Bridge Configuration

The power dissipation must be taken into account to maintain the gate driver within the thermal limit. The power loss of the gate driver includes the quiescent loss and the switching loss, which can be calculated as:

$$P_{DR} = P_Q + P_{SW} \quad (4)$$

P_Q is the quiescent power loss for the driver, which is $I_q \times (V_{DD} - V_{EE}) = 5 \text{ mA} \times 20 \text{ V} = 0.100 \text{ W}$. The quiescent power loss is the power consumed by the internal circuits such as the input stage, reference voltage, logic circuits, protection circuits when the driver is switching when the driver is biased with VDD and VEE, and also the charging and discharging current of the internal circuit when the driver is switching. The power dissipation when the driver is switching can be calculated as:

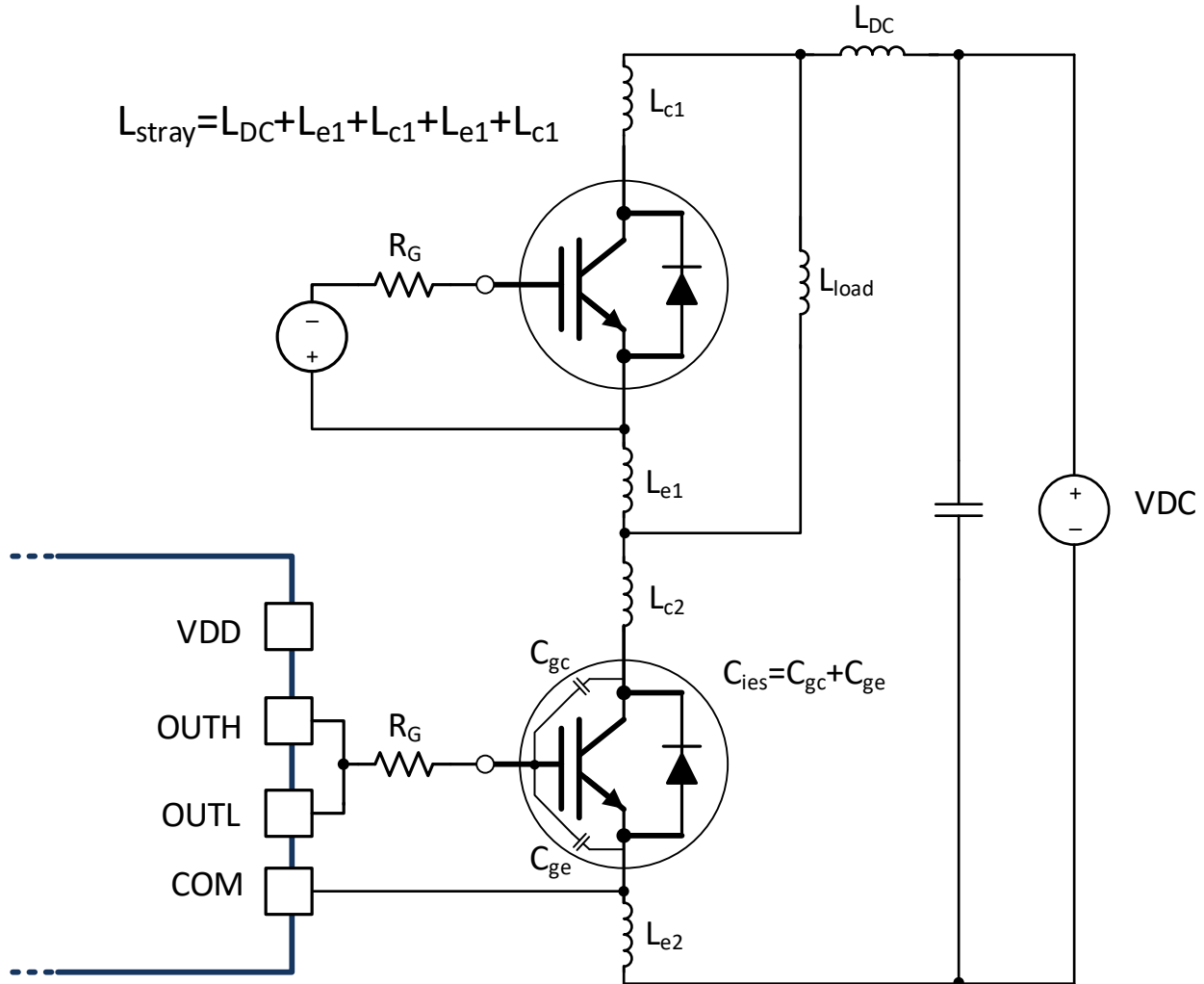
$$P_{SW} = \frac{1}{2} \cdot \left(\frac{R_{OH_EFF}}{R_{OH_EFF} + R_{ON} + R_{G_Int}} + \frac{R_{OL}}{R_{OL} + R_{OFF} + R_{G_Int}} \right) \cdot (V_{DD} - V_{EE}) \cdot f_{sw} \cdot Q_g \quad (5)$$

Where

- Q_g is the gate charge required at the operation point to fully charge the gate voltage from VEE to VDD
- f_{sw} is the switching frequency

In this example, the P_{SW} can be calculated as:

$$P_{SW} = \frac{1}{2} \cdot \left(\frac{R_{OH_EFF}}{R_{OH_EFF} + R_{ON} + R_{G_Int}} + \frac{R_{OL}}{R_{OL} + R_{OFF} + R_{G_Int}} \right) \cdot (VDD - VEE) \cdot f_{sw} \cdot Q_g = 0.505W \quad (6)$$

Thus, the total power loss is:

$$P_{DR} = P_Q + P_{SW} = 0.10W + 0.505W = 0.605W \quad (7)$$

When the board temperature is 125°C, the junction temperature can be estimated as:

$$T_j = T_b + \psi_{jb} \cdot P_{DR} \approx 150^\circ C \quad (8)$$

Therefore, for the application in this example, with 125°C board temperature, the maximum switching frequency is approximately 50 kHz to keep the gate driver in the thermal limit. By using a lower switching frequency, or increasing external gate resistance, the gate driver can be operated at a higher switching frequency.

9.2.2.6 Overcurrent and Short Circuit Protection

A standard desaturation circuit can be applied to the DESAT pin. If the voltage of the DESAT pin is higher than the threshold V_{DESAT} , the soft turn-off is initiated. A fault is reported to the input side to DSP/MCU. The output is held to LOW after the fault is detected, and can only be reset by the RST/EN pin. The state-of-art overcurrent and short circuit detection time helps to ensure a short shutdown time for SiC MOSFET and IGBT.

If DESAT pin is not in use, it must be tied to COM to avoid overcurrent fault false triggering.

- TI recommends fast reverse recovery high voltage diode in the desaturation circuit. A resistor is recommended in series with the high voltage diode to limit the inrush current.
- TI recommends a Schottky diode from COM to DESAT to prevent driver damage caused by negative voltage.
- TI recommends a Zener diode from COM to DESAT to prevent driver damage caused by positive voltage.

9.2.2.7 Isolated Analog Signal Sensing

The isolated analog signal sensing feature provides a simple isolated channel for the isolated temperature detection, voltage sensing and so forth. One typical application of this function is the temperature monitor of the power semiconductor. Thermal diodes or temperature sensing resistors are integrated in the SiC MOSFET or IGBT module close to the dies to monitor the junction temperature. The UCC21750 has an internal 200- μ A current source with $\pm 3\%$ accuracy across temperature, which can forward bias the thermal diodes or create a voltage drop on the temperature sensing resistors. The sensed voltage from the AIN pin is passed through the isolation barrier to the input side and transformed to a PWM signal. The duty cycle of the PWM changes linearly from 10% to 88% when the AIN voltage changes from 4.5 V to 0.6 V and can be represented using [方程式 9](#).

$$D_{APWM}(\%) = -20 * V_{AIN} + 100 \quad (9)$$

9.2.2.7.1 Isolated Temperature Sensing

A typical application circuit is shown in [图 9-7](#). To sense temperature, the AIN pin is connected to the thermal diode or thermistor which can be discrete or integrated within the power module. TI recommends a low pass filter for the AIN input. Because the temperature signal does not have a high bandwidth, the low pass filter is mainly used for filtering the noise introduced by the switching of the power device, which does not require stringent control for propagation delay. The filter capacitance for C_{filt} can be chosen between 1 nF to 100 nF and the filter resistance R_{filt} between 1 Ω to 10 Ω according to the noise level.

The output of APWM is directly connected to the microcontroller to measure the duty cycle dependent on the voltage input at AIN, using [方程式 9](#).



图 9-7. Thermal Diode or Thermistor Temperature Sensing Configuration

When a high-precision voltage supply for VCC is used on the primary side of UCC21750 the duty cycle output of APWM can also be filtered and the voltage measured using the microcontroller's ADC input pin, as shown in 图 9-8. The frequency of APWM is 400 kHz, so the value for R_{filt_2} and C_{filt_2} must be such that the cutoff frequency is below 400 kHz. Temperature does not change rapidly, thus the rise time due to the RC constant of the filter is not under a strict requirement.

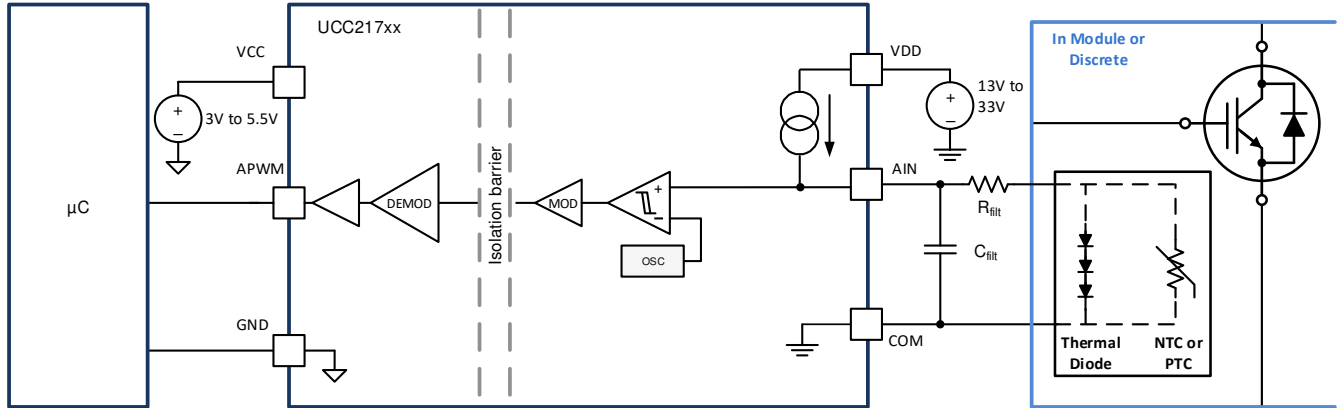

图 9-8. APWM Channel with Filtered Output

The example below shows the results using a 4.7-k Ω NTC, NTCS0805E3472FMT, in series with a 3-k Ω resistor and also the thermal diode using four diode-connected MMBT3904 NPN transistors. The sensed voltage of the 4 MMBT3904 thermal diodes connected in series ranges from about 2.5 V to 1.6 V from 25°C to 135°C, corresponding to 50% to 68% duty cycle. The sensed voltage of the NTC thermistor connected in series with the 3-k Ω resistor ranges from about 1.5 V to 0.6 V from 25°C to 135°C, corresponding to 70% to 88% duty cycle. The voltage at VAIN of both sensors and the corresponding measured duty cycle at APWM is shown in 图 9-9.

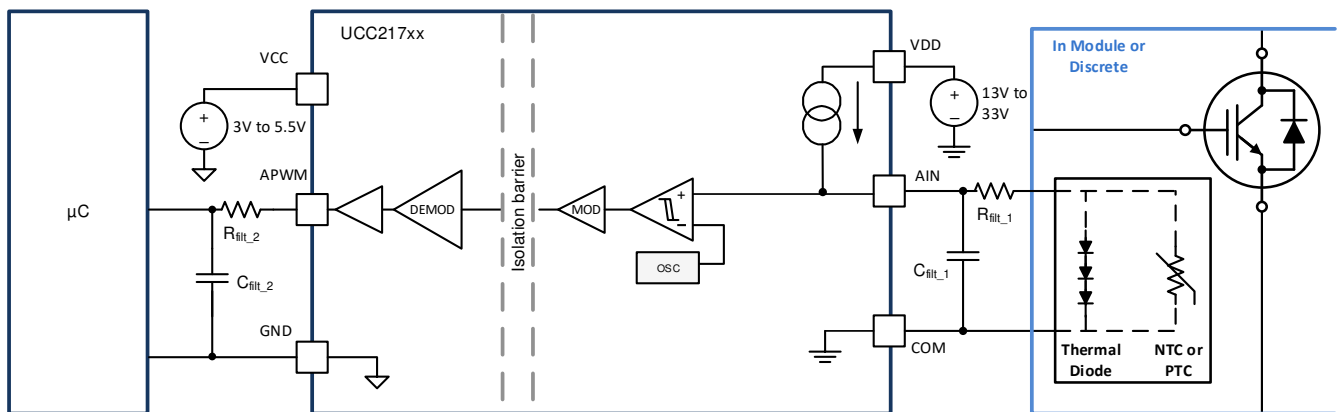

图 9-9. Thermal Diode and NTC V_{AIN} and Corresponding Duty Cycle at APWM

The duty cycle output has an accuracy of $\pm 3\%$ throughout temperature without any calibration, as shown in 图 9-10 but with single-point calibration at 25°C, the duty accuracy can be improved to $\pm 1\%$, as shown in 图 9-11.



图 9-10. APWM Duty Error Without Calibration

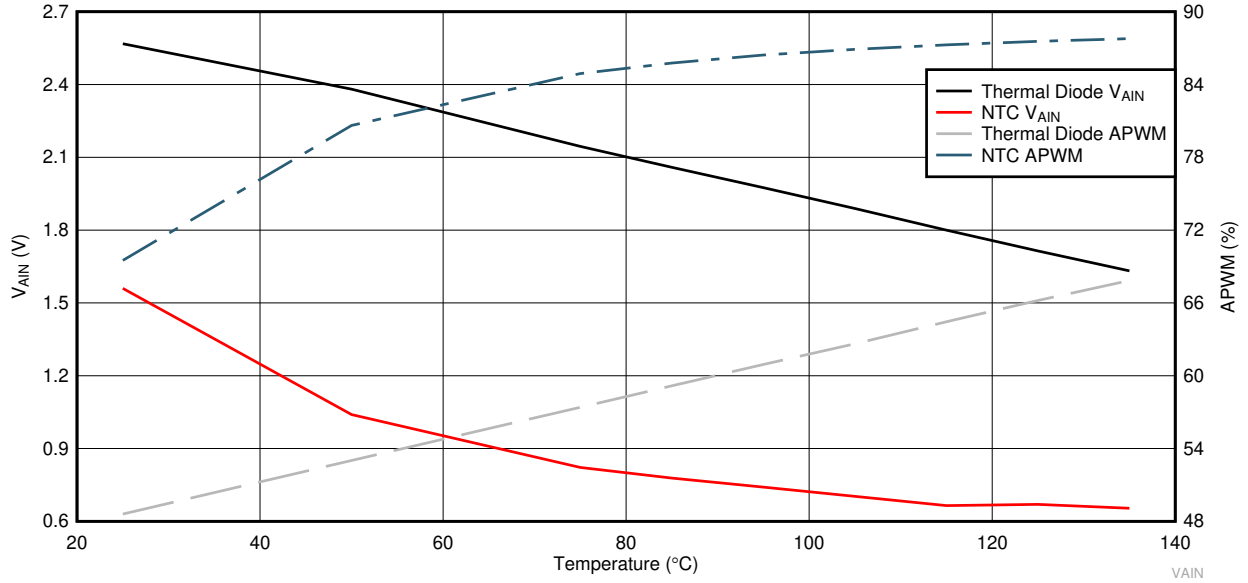

图 9-11. APWM Duty Error With Single-Point Calibration

9.2.2.7.2 Isolated DC Bus Voltage Sensing

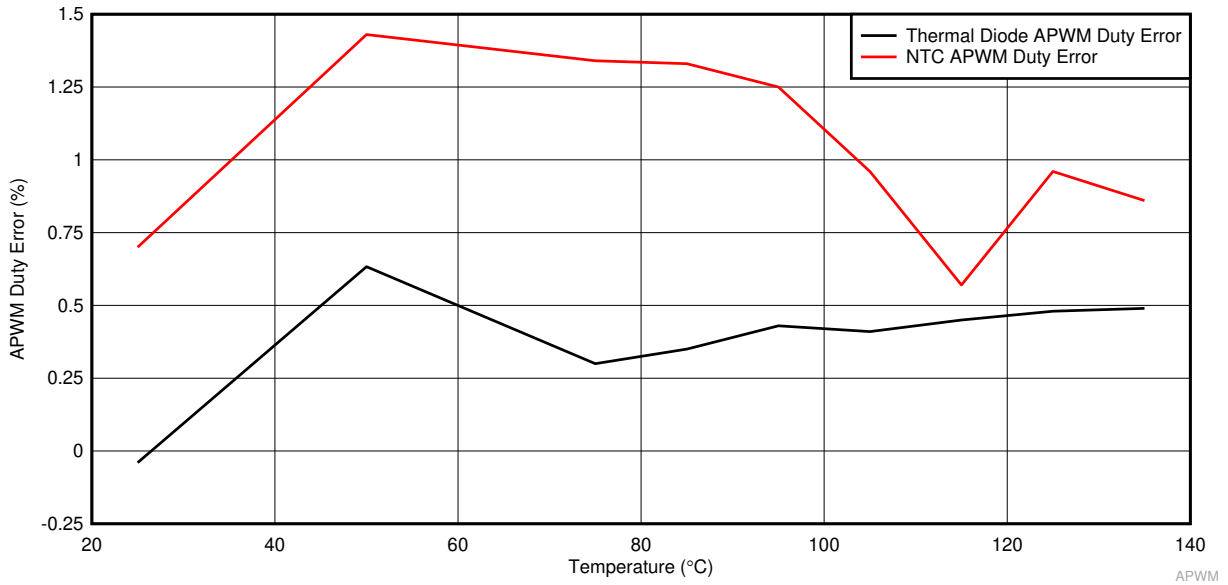
The AIN to APWM channel can be used for other applications such as the DC-link voltage sensing, as shown in 图 9-12. The same filtering requirements as given above can be used in this case, as well. The number of attenuation resistors, R_{atten_1} through R_{atten_n} , is dependent on the voltage level and power rating of the resistor. The voltage is finally measured across R_{LV_DC} to monitor the stepped-down voltage of the HV DC-link which must fall within the voltage range of AIN from 0.6 V to 4.5 V. The driver must be referenced to the same point as the measurement reference, thus in the case shown below the UCC21750 is driving the lower IGBT in the half-bridge and the DC-link voltage measurement is referenced to COM. The internal current source I_{AIN} must be taken into account when designing the resistor divider. The AIN pin voltage is:

$$V_{AIN} = \frac{R_{LV_DC}}{R_{LV_DC} + \sum_{i=1}^n R_{atten_i}} \cdot V_{DC} + R_{LV_DC} \cdot I_{AIN} \quad (10)$$

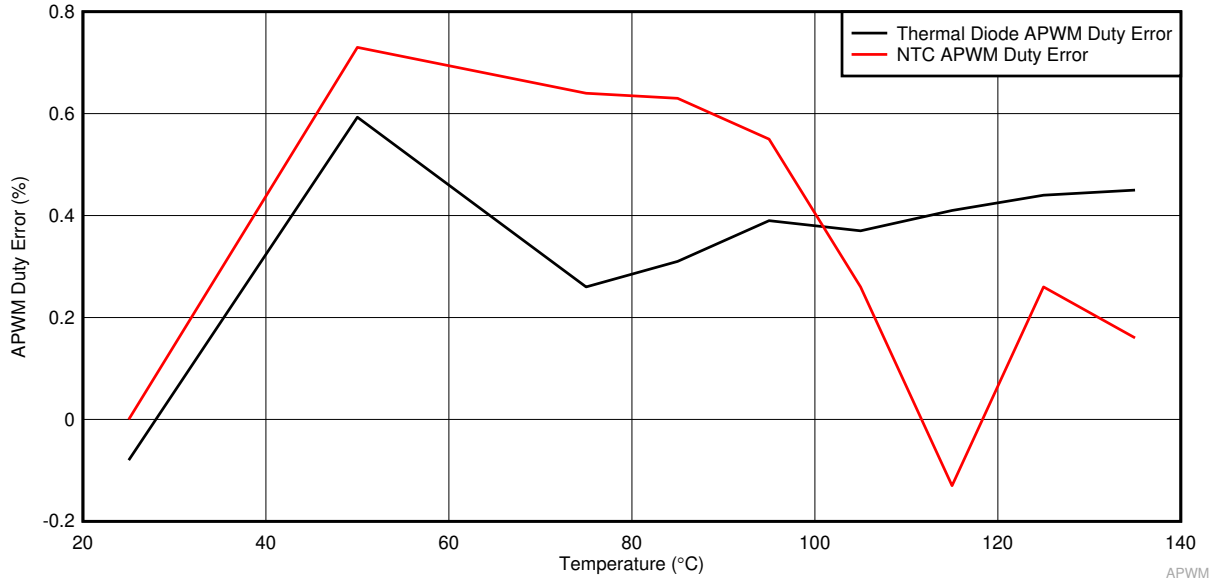

图 9-12. DC-link Voltage Sensing Configuration

9.2.2.8 Higher Output Current Using an External Current Buffer

To increase the IGBT gate drive current, a non-inverting current buffer (such as the NPN/PNP buffer shown in [图 9-13](#)) can be used. Inverting types are not compatible with the desaturation fault protection circuitry and must be avoided. The MJD44H11/MJD45H11 pair is appropriate for peak currents up to 15 A, the D44VH10/ D45VH10 pair is up to 20-A peak.

In the case of an over-current detection, the soft turn off (STO) is activated. External components must be added to implement STO instead of normal turn off speed when an external buffer is used. C_{STO} sets the timing for soft turn off and R_{STO} limits the inrush current to below the current rating of the internal FET (10A). R_{STO} must be at least $(VDD - VEE)/10$. The soft turn off timing is determined by the internal current source of 400 mA and the capacitor C_{STO} . C_{STO} is calculated using [方程式 11](#).

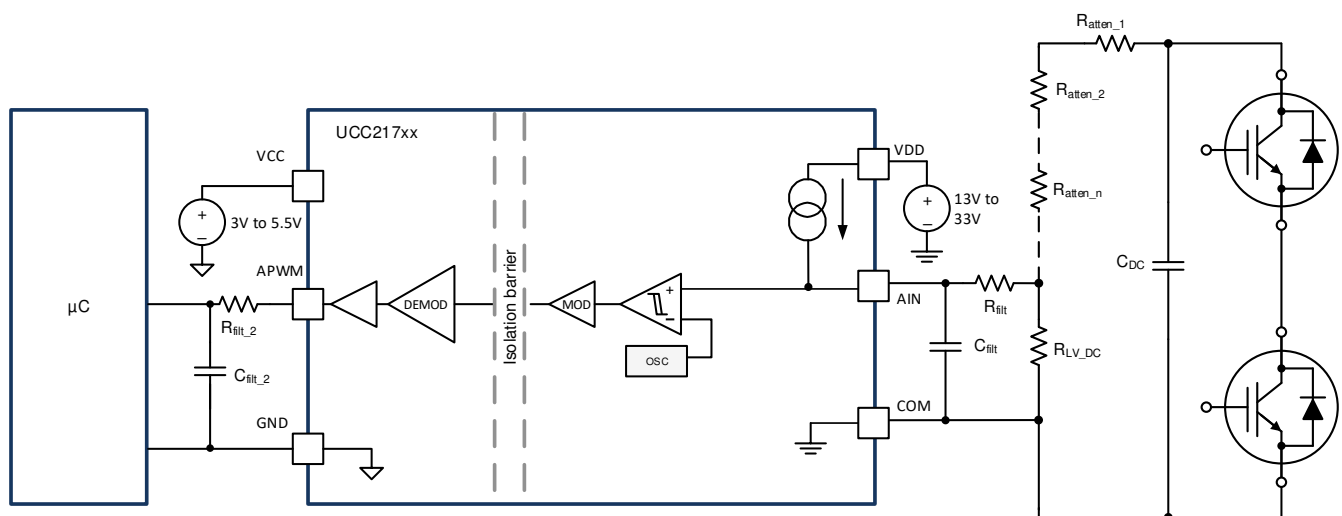
$$C_{STO} = \frac{I_{STO} \cdot t_{STO}}{VDD - VEE} \tag{11}$$

- I_{STO} is the internal STO current source, 400 mA
- t_{STO} is the desired STO timing



图 9-13. Current Buffer for Increased Drive Strength

9.2.3 Application Curves



图 9-14. PWM Input (Yellow) and Driver Output (Blue)

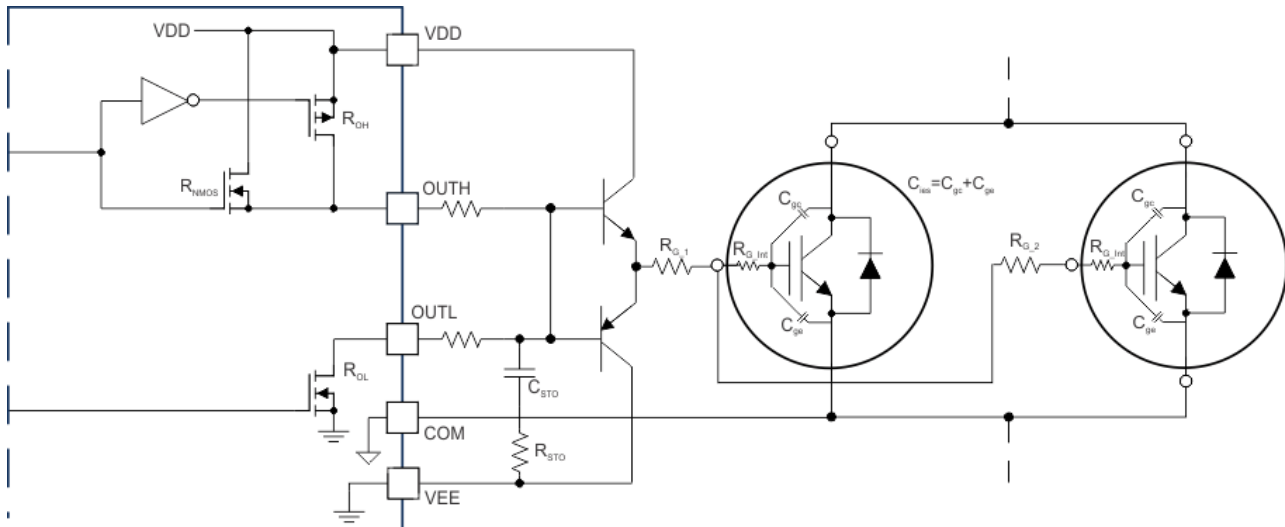

图 9-15. AIN Step Input (Green) and APWM Output (Pink)

10 Power Supply Recommendations

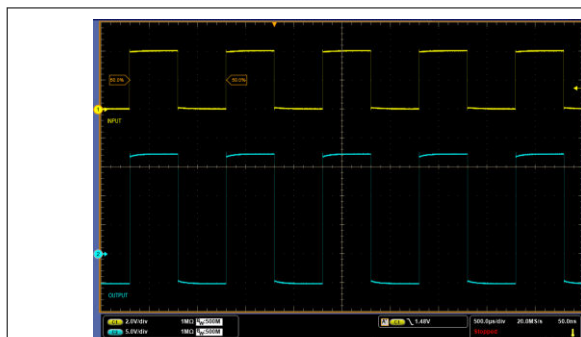
During the turn on and turn off switching transient, the peak source and sink current is provided by the VDD and VEE power supply. The large peak current is possible to drain the VDD and VEE voltage level and cause a voltage droop on the power supplies. To stabilize the power supply and ensure a reliable operation, TI recommends a set of decoupling capacitors at the power supplies. Considering the UCC21750 has ± 10 -A peak drive strength and can generate high dV/dt , TI recommends a 10- μ F bypass cap between VDD and COM, VEE and COM. TI recommends a 1- μ F bypass cap between VCC and GND due to less current comparing with output side power supplies. A 0.1- μ F decoupling cap is also recommended for each power supply to filter out high frequency noise. The decoupling capacitors must be low ESR and ESL to avoid high frequency noise, and must be placed as close as possible to the VCC, VDD and VEE pins to prevent noise coupling from the system parasitics of PCB layout.

11 Layout

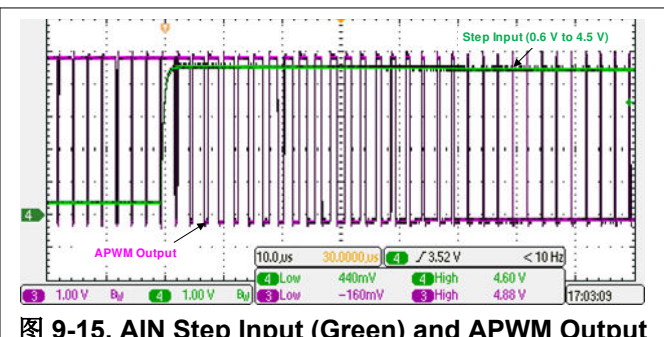
11.1 Layout Guidelines

Due to the strong drive strength of the UCC21750, careful considerations must be taken in PCB design. Below are some key points:

- The driver must be placed as close as possible to the power semiconductor to reduce the parasitic inductance of the gate loop on the PCB traces.
- The decoupling capacitors of the input and output power supplies must be placed as close as possible to the power supply pins. The peak current generated at each switching transient can cause high di/dt and voltage spike on the parasitic inductance of PCB traces.
- The driver COM pin must be connected to the Kelvin connection of SiC MOSFET source or IGBT emitter. If the power device does not have a split Kelvin source or emitter, the COM pin must be connected as close as possible to the source or emitter terminal of the power device package to separate the gate loop from the high power switching loop
- Use a ground plane on the input side to shield the input signals. The input signals can be distorted by the high frequency noise generated by the output side switching transients. The ground plane provides a low-inductance filter for the return current flow.
- If the gate driver is used for the low side switch which the COM pin connected to the dc bus negative, use the ground plane on the output side to shield the output signals from the noise generated by the switch node; if the gate driver is used for the high side switch, which the COM pin is connected to the switch node, ground plane is not recommended
- If ground plane is not used on the output side, separate the return path of the DESAT and AIN ground loop from the gate loop ground which has large peak source and sink current.
- No PCB trace or copper is allowed under the gate driver. TI recommends a PCB cutout to avoid any noise coupling between the input and output side which can contaminate the isolation barrier.

11.2 Layout Example



图 11-1. Layout Example

12 Device and Documentation Support

12.1 Device Support

12.1.1 第三方产品免责声明

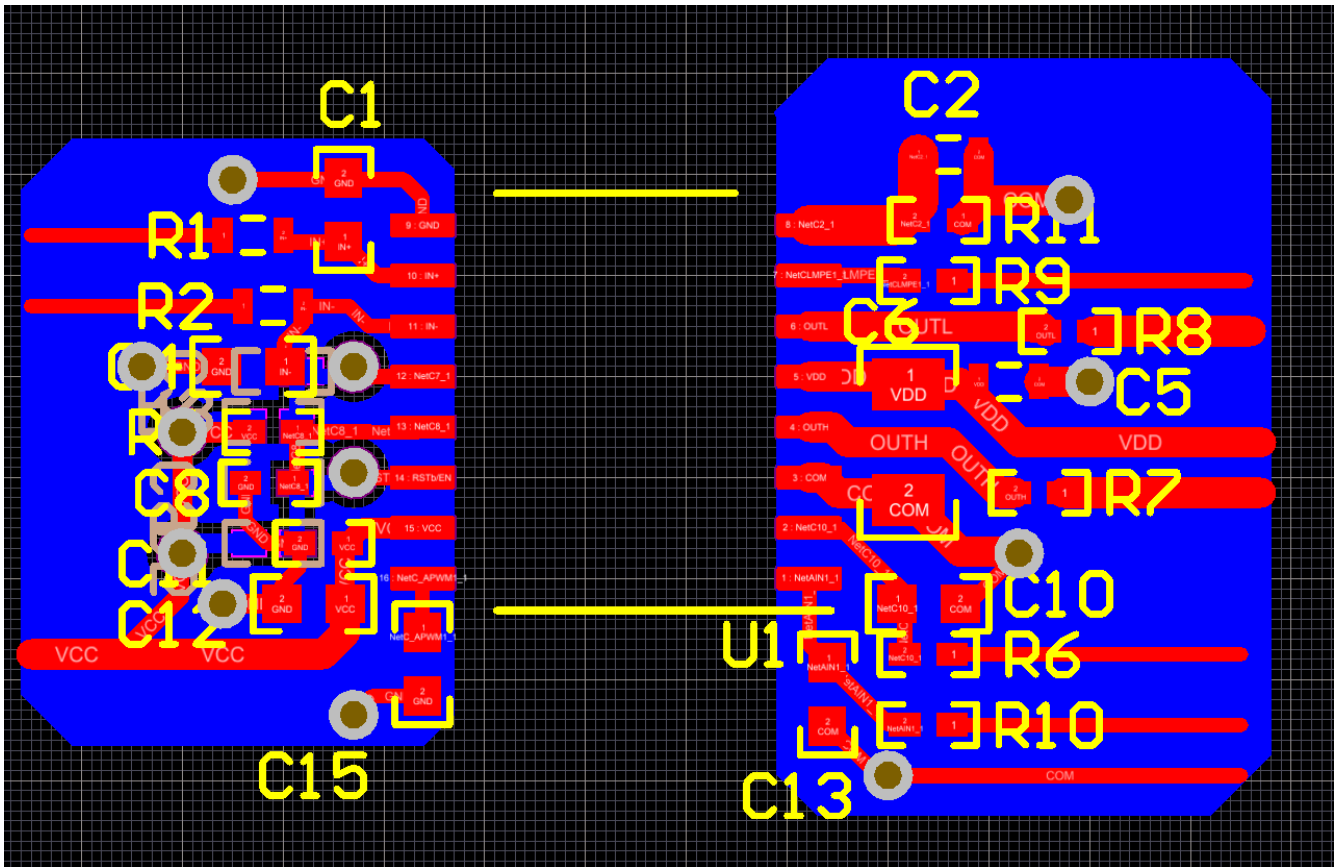
TI 发布的与第三方产品或服务有关的信息，不能构成与此类产品或服务或保修的适用性有关的认可，不能构成此类产品或服务单独或与任何 TI 产品或服务一起的表示或认可。

12.2 Documentation Support

12.2.1 Related Documentation

For related documentation see the following:

- [Isolation Glossary](#)

12.3 接收文档更新通知

要接收文档更新通知，请导航至 [ti.com](https://www.ti.com) 上的器件产品文件夹。点击 [订阅更新](#) 进行注册，即可每周接收产品信息更改摘要。有关更改的详细信息，请查看任何已修订文档中包含的修订历史记录。

12.4 支持资源

[TI E2E™ 支持论坛](#) 是工程师的重要参考资料，可直接从专家获得快速、经过验证的解答和设计帮助。搜索现有解答或提出自己的问题可获得所需的快速设计帮助。

链接的内容由各个贡献者“按原样”提供。这些内容并不构成 TI 技术规范，并且不一定反映 TI 的观点；请参阅 TI 的 [《使用条款》](#)。

12.5 Trademarks

TI E2E™ is a trademark of Texas Instruments.

所有商标均为其各自所有者的财产。

12.6 静电放电警告



静电放电 (ESD) 会损坏这个集成电路。德州仪器 (TI) 建议通过适当的预防措施处理所有集成电路。如果不遵守正确的处理和安装程序，可能会损坏集成电路。

ESD 的损坏小至导致微小的性能降级，大至整个器件故障。精密的集成电路可能更容易受到损坏，这是因为非常细微的参数更改都可能会导致器件与其发布的规格不相符。

12.7 术语表

[TI 术语表](#) 本术语表列出并解释了术语、首字母缩略词和定义。

13 Mechanical, Packaging, and Orderable Information

The following pages include mechanical packaging and orderable information. This information is the most current data available for the designated devices. This data is subject to change without notice and revision of this document. For browser-based versions of this data sheet, refer to the left-hand navigation.

PACKAGING INFORMATION

Orderable Device	Status (1)	Package Type	Package Drawing	Pins	Package Qty	Eco Plan (2)	Lead finish/ Ball material (6)	MSL Peak Temp (3)	Op Temp (°C)	Device Marking (4/5)	Samples
UCC21750DW	LIFEBUY	SOIC	DW	16	40	RoHS & Green	NIPDAU	Level-2-260C-1 YEAR	-40 to 125	UCC21750	
UCC21750DWR	ACTIVE	SOIC	DW	16	2000	RoHS & Green	NIPDAU	Level-2-260C-1 YEAR	-40 to 125	UCC21750	Samples

(1) The marketing status values are defined as follows:

ACTIVE: Product device recommended for new designs.

LIFEBUY: TI has announced that the device will be discontinued, and a lifetime-buy period is in effect.

NRND: Not recommended for new designs. Device is in production to support existing customers, but TI does not recommend using this part in a new design.

PREVIEW: Device has been announced but is not in production. Samples may or may not be available.

OBSELETE: TI has discontinued the production of the device.

(2) **RoHS:** TI defines "RoHS" to mean semiconductor products that are compliant with the current EU RoHS requirements for all 10 RoHS substances, including the requirement that RoHS substance do not exceed 0.1% by weight in homogeneous materials. Where designed to be soldered at high temperatures, "RoHS" products are suitable for use in specified lead-free processes. TI may reference these types of products as "Pb-Free".

RoHS Exempt: TI defines "RoHS Exempt" to mean products that contain lead but are compliant with EU RoHS pursuant to a specific EU RoHS exemption.

Green: TI defines "Green" to mean the content of Chlorine (Cl) and Bromine (Br) based flame retardants meet JS709B low halogen requirements of <=1000ppm threshold. Antimony trioxide based flame retardants must also meet the <=1000ppm threshold requirement.

(3) MSL, Peak Temp. - The Moisture Sensitivity Level rating according to the JEDEC industry standard classifications, and peak solder temperature.

(4) There may be additional marking, which relates to the logo, the lot trace code information, or the environmental category on the device.

(5) Multiple Device Markings will be inside parentheses. Only one Device Marking contained in parentheses and separated by a "~" will appear on a device. If a line is indented then it is a continuation of the previous line and the two combined represent the entire Device Marking for that device.

(6) Lead finish/Ball material - Orderable Devices may have multiple material finish options. Finish options are separated by a vertical ruled line. Lead finish/Ball material values may wrap to two lines if the finish value exceeds the maximum column width.

Important Information and Disclaimer:The information provided on this page represents TI's knowledge and belief as of the date that it is provided. TI bases its knowledge and belief on information provided by third parties, and makes no representation or warranty as to the accuracy of such information. Efforts are underway to better integrate information from third parties. TI has taken and continues to take reasonable steps to provide representative and accurate information but may not have conducted destructive testing or chemical analysis on incoming materials and chemicals. TI and TI suppliers consider certain information to be proprietary, and thus CAS numbers and other limited information may not be available for release.

In no event shall TI's liability arising out of such information exceed the total purchase price of the TI part(s) at issue in this document sold by TI to Customer on an annual basis.

OTHER QUALIFIED VERSIONS OF UCC21750 :

- Automotive : [UCC21750-Q1](#)

NOTE: Qualified Version Definitions:

- Automotive - Q100 devices qualified for high-reliability automotive applications targeting zero defects

GENERIC PACKAGE VIEW

DW 16

SOIC - 2.65 mm max height

7.5 x 10.3, 1.27 mm pitch

SMALL OUTLINE INTEGRATED CIRCUIT

This image is a representation of the package family, actual package may vary.
Refer to the product data sheet for package details.



4224780/A



DW0016B

PACKAGE OUTLINE

SOIC - 2.65 mm max height

SOIC



4221009/B 07/2016

NOTES:

1. All linear dimensions are in millimeters. Dimensions in parenthesis are for reference only. Dimensioning and tolerancing per ASME Y14.5M.
2. This drawing is subject to change without notice.
3. This dimension does not include mold flash, protrusions, or gate burrs. Mold flash, protrusions, or gate burrs shall not exceed 0.15 mm, per side.
4. This dimension does not include interlead flash. Interlead flash shall not exceed 0.25 mm, per side.
5. Reference JEDEC registration MS-013.

EXAMPLE BOARD LAYOUT

DW0016B

SOIC - 2.65 mm max height

SOIC



LAND PATTERN EXAMPLE
SCALE:4X



SOLDER MASK DETAILS

4221009/B 07/2016

NOTES: (continued)

- 6. Publication IPC-7351 may have alternate designs.
- 7. Solder mask tolerances between and around signal pads can vary based on board fabrication site.

EXAMPLE STENCIL DESIGN

DW0016B

SOIC - 2.65 mm max height

SOIC



NOTES: (continued)

8. Laser cutting apertures with trapezoidal walls and rounded corners may offer better paste release. IPC-7525 may have alternate design recommendations.
9. Board assembly site may have different recommendations for stencil design.

重要声明和免责声明

TI“按原样”提供技术和可靠性数据（包括数据表）、设计资源（包括参考设计）、应用或其他设计建议、网络工具、安全信息和其他资源，不保证没有瑕疵且不做任何明示或暗示的担保，包括但不限于对适销性、某特定用途方面的适用性或不侵犯任何第三方知识产权的暗示担保。

这些资源可供使用 TI 产品进行设计的熟练开发人员使用。您将自行承担以下全部责任：(1) 针对您的应用选择合适的 TI 产品，(2) 设计、验证并测试您的应用，(3) 确保您的应用满足相应标准以及任何其他功能安全、信息安全、监管或其他要求。

这些资源如有变更，恕不另行通知。TI 授权您仅可将这些资源用于研发本资源所述的 TI 产品的应用。严禁对这些资源进行其他复制或展示。您无权使用任何其他 TI 知识产权或任何第三方知识产权。您应全额赔偿因在这些资源的使用中对 TI 及其代表造成的任何索赔、损害、成本、损失和债务，TI 对此概不负责。

TI 提供的产品受 [TI 的销售条款](#) 或 [ti.com](#) 上其他适用条款/TI 产品随附的其他适用条款的约束。TI 提供这些资源并不会扩展或以其他方式更改 TI 针对 TI 产品发布的适用的担保或担保免责声明。

TI 反对并拒绝您可能提出的任何其他或不同的条款。

邮寄地址：Texas Instruments, Post Office Box 655303, Dallas, Texas 75265
Copyright © 2024，德州仪器 (TI) 公司