

# Designing a Premium Audio System

**Gregg Scott**  
**Senior Applications Engineer**  
**Mid Power Audio Amplifiers**

# Gregg Scott

Senior Applications Engineer, MPAA

- **Career**

- California Polytechnic State University, San Luis Obispo, CA
  - BSEE 1984
- 34 years spanning automotive audio, home audio, and magnetics design

- **Expertise**

- Automotive audio system designs
- Class D amplifiers
- Automotive EMC
- Wound magnetics



# Detailed agenda

- What is meant by Premium Sound
- Digital to Analog Converters
  - Single Ended vs. Differential Output
  - Output Noise Filtering
  - miniDSP and SmartAmp
- TPA6404-Q1
  - 2.1MHz PWM
- External Components
  - Schematic
  - Best practices PCB Layout

# Systems overview

- **What problem is being solved?**
  - A digital input solution for a Premium Audio Solution for Automotive Audio
- **Please provide a brief description of this system solution:**
  - Utilizing high quality Digital to Analog Converters and TPA6404-Q1, several solutions are provided based on the requirements.
- **What are the key components in the system?**
  - TPA6404-Q1
  - PCM175x, PCM510xA, and PCM5242/PCM5252 family of DACs

# What is Premium Sound?

- This is a difficult question because it is based on opinions.
  - Some think it is sound quality
  - Some think it is exceptional specifications
- We will discuss it from a sound quality aspect as well as specifications and how it relates to certain measurements, such as
  - Noise
  - THD
  - IMD
  - Group Delay
  - Audio Bandwidth

# Noise, THD, and IMD

- Noise
  - We all know about noise and it does not sound good
- THD+n
  - Total Harmonic Distortion. This is used by all amplifier designers to evaluate the linearity of the amplifier.
  - Can we hear THD?
- IMD
  - Intermodulation Distortion. This is when two frequencies mix and cause non-linearities in an amplifier system.
  - Can we hear IMD?

# Group delay in audio

- Group delay is a useful measure of time distortion. The group delay is a measure of the slope of the phase response at any given frequency. Variations in group delay cause signal distortion.
- Group delay has some importance in the audio. Many components of an audio reproduction chain, such as loudspeakers and multiway loudspeaker crossover networks, cause group delay in the audio signal.
- Is group delay audible?

# Designing a digital input premium audio system

As in any system design, one breaks down the system into parts. Each part is designed and then the interface between the parts is designed so that the parts function properly as a whole.

- The digital to analog converter design will be discussed along with the interface to the amplifier stage.
- The amplifier stage design will be discussed to finalize the premium audio system.



# DACs for Driving Class-D Amplifiers

ASC-DC-DAC  
2018

# Single Ended vs Differential vs Direct Path Outputs

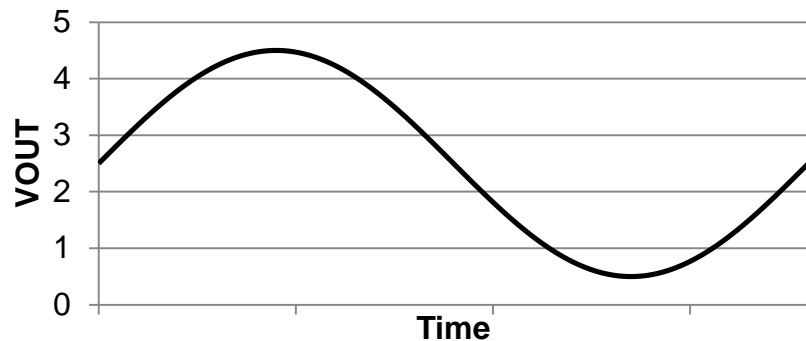

Single Ended, DC Bias – PCM175x

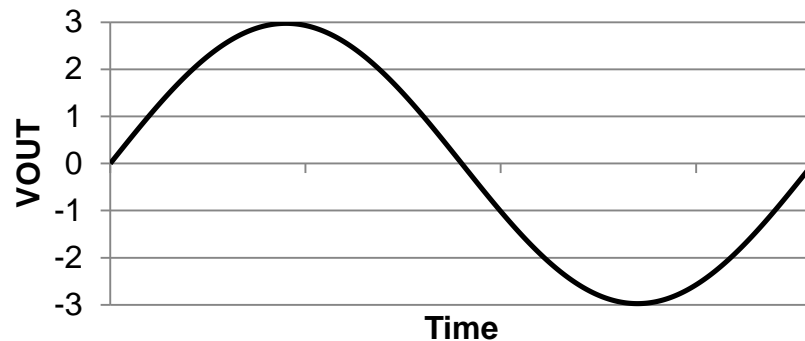

Single Ended, DirectPath™ - PCM5102A

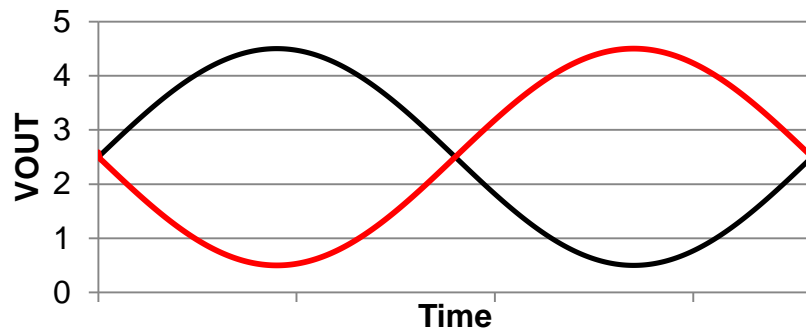

Differential, DC Bias – PCM1789

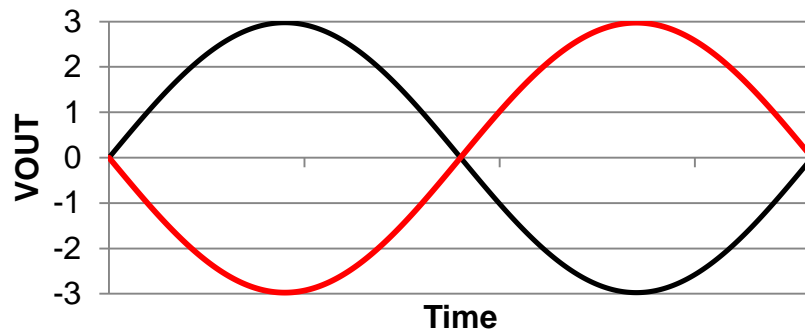

Differential, DirectPath™ - PCM5242

# PCM175x

## High Performance 24-bit Stereo Audio DACs

### Features

- 2x DAC with 24-bit, 192KHz PCM interface
  - **SNR: 106dB / THD + N: up to -94dB**
- 4th-order noise shaping and 8-level amplitude quantization
- Single 5V power supply
- Hardware Controlled (PCM1754)
- Software Controlled (PCM1753)
- Automotive Qualified

### Applications

A/V Receivers  
Navigation Systems

Car Audio  
Multitrack recorders

### Benefits

- High quality sound with good jitter performance
- Excellent dynamic performance and improved jitter tolerance
- Reduce system complexity/multiple power rails
- SW development costs reduced

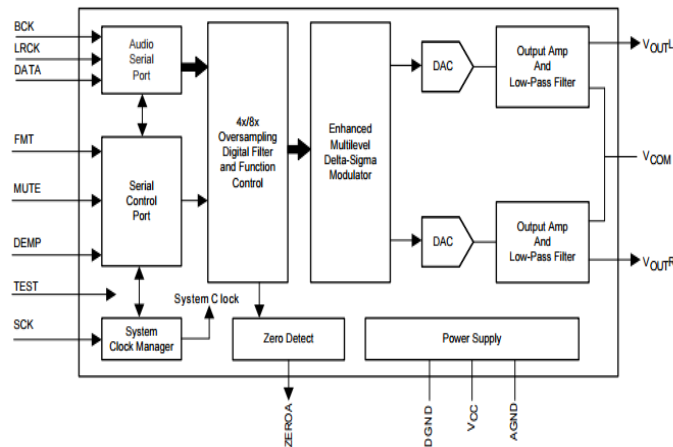

# DAC Sampling and Out-of-Band Noise

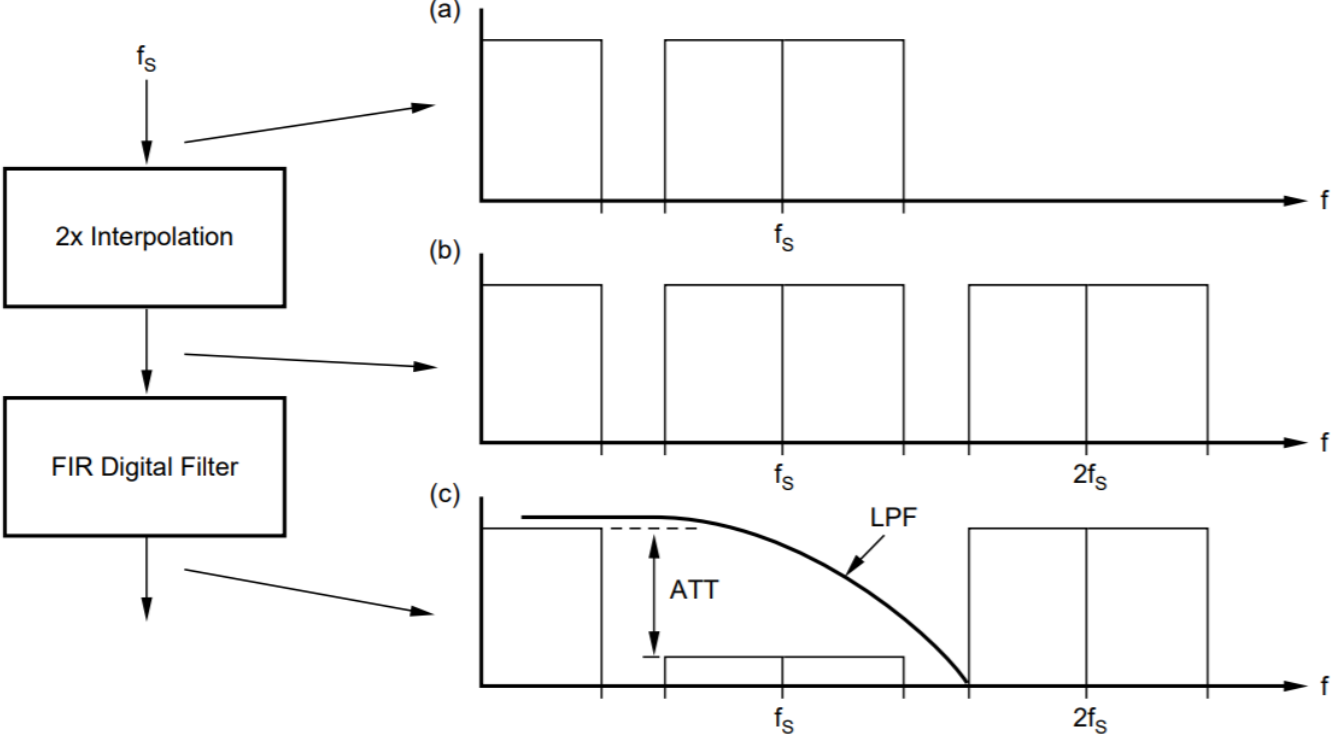

# DAC Sampling and Out-of-Band Noise

- Attenuating OoB noise is usually accomplished by external filtering
- Ideal filtering would reject all OoB
- No filter is ideal, and roll-off can still allow noise near the audible band.

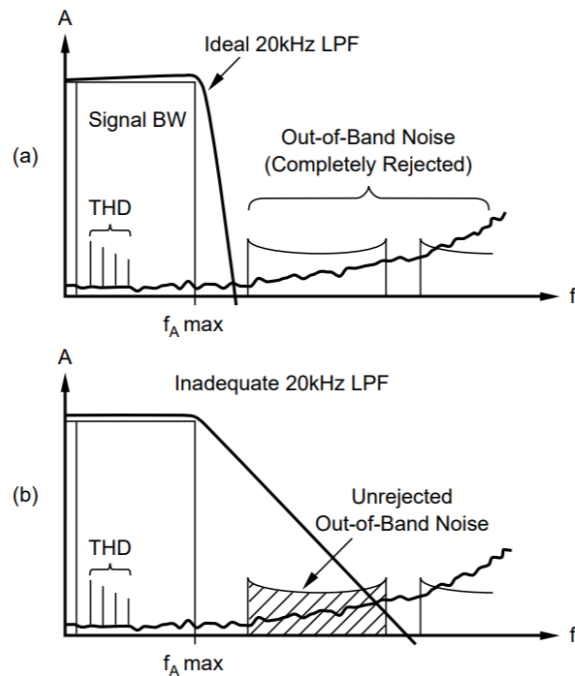
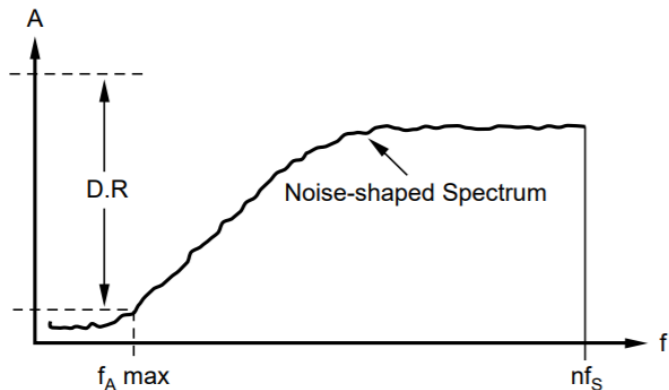

# PCM175x Noise Performance

- PCM175x architecture implements digital filters and oversampling that move the output noise energy out of the audible band (20Hz-20kHz)
- Out-of-band noise can still impact system performance by causing unwanted aliasing in the analog signal path
- Noise shaping is improved in more advanced devices, such as the PCM5xxx family

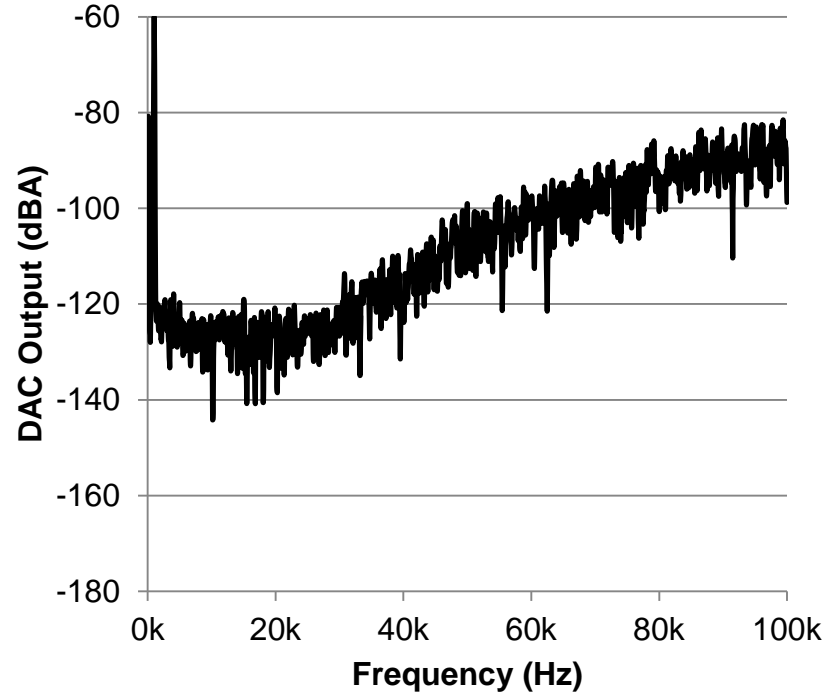

# Common Output Filter Types

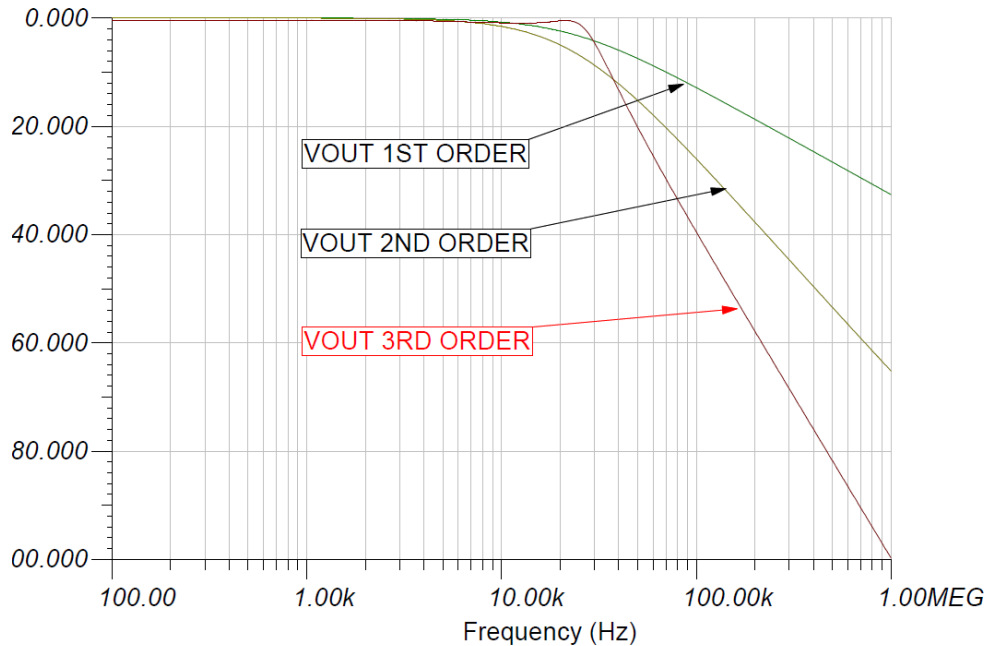
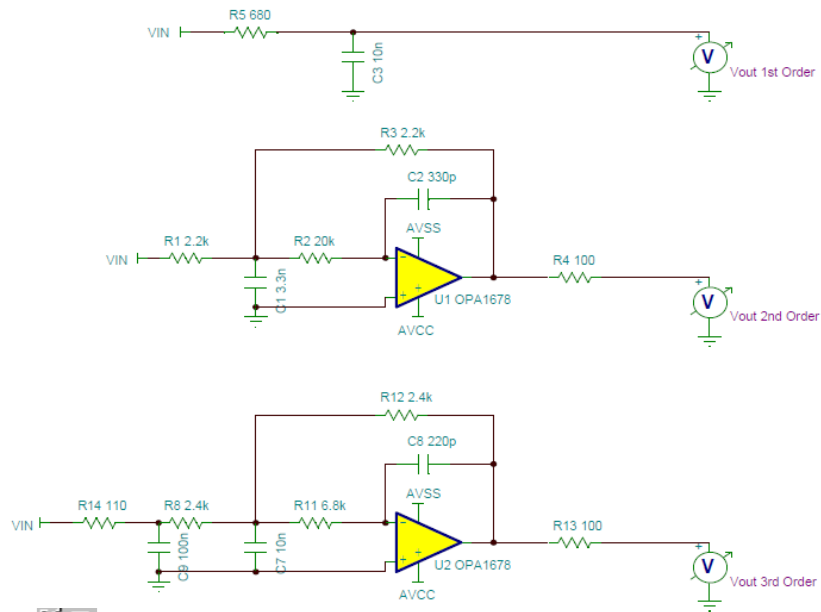

PCM Output Filter.TSC

# External Noise Filter Configurations

## Passive 1<sup>st</sup> Order RC LPF

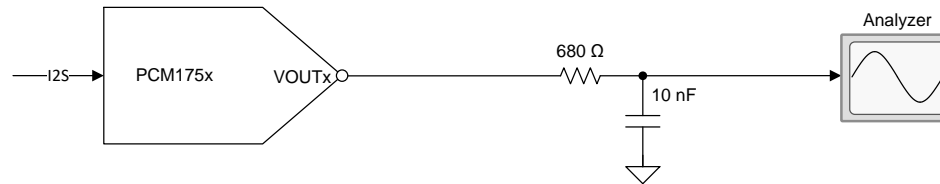

## Active 2<sup>nd</sup> Order LPF

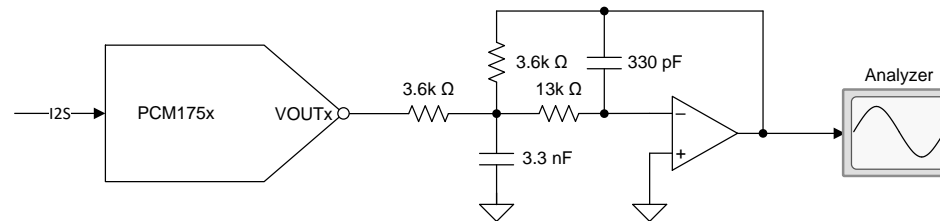



# PCM175x with Active Filtering

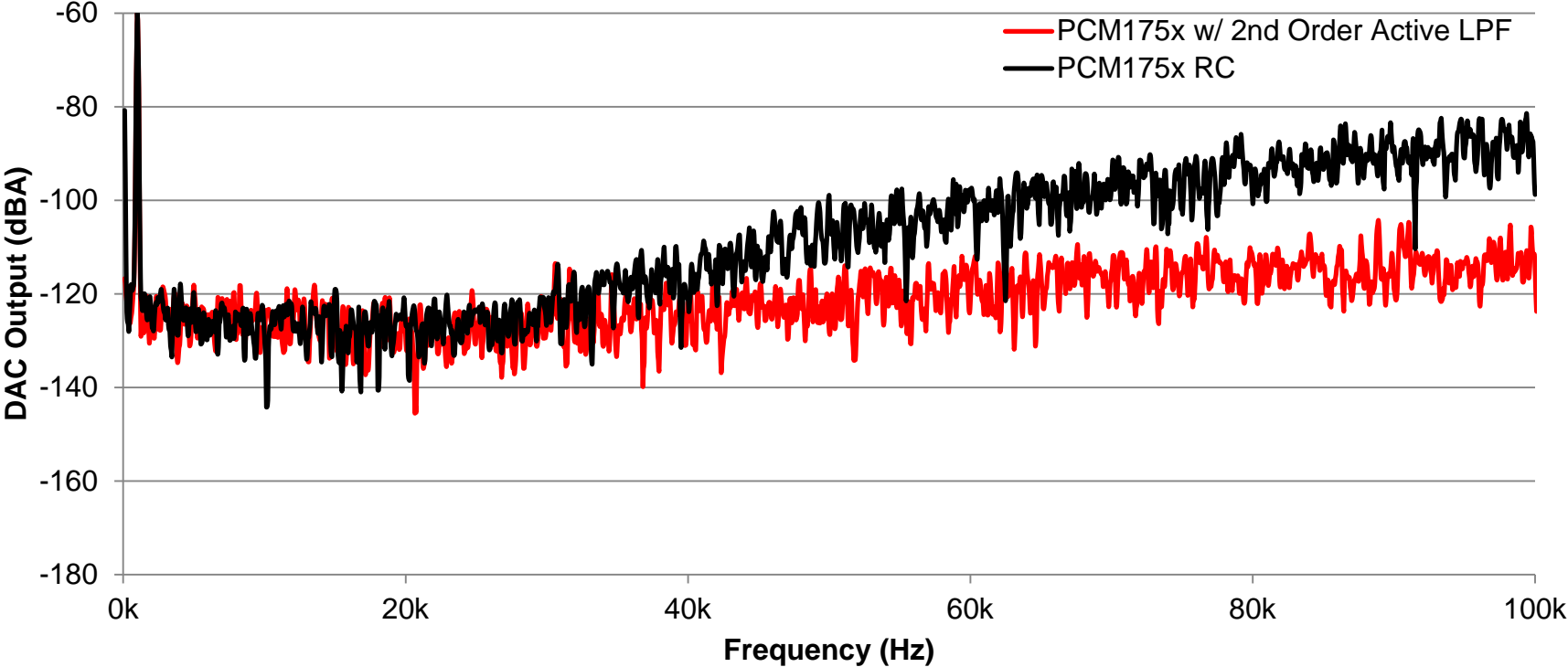

# PCM175x With The TPA6404-Q1

- $f_C = 24\text{kHz}$  2<sup>nd</sup> order active filter
- DC blocking caps used with input impedance for HPF as recommended for the TPA6404-Q1
- Thin film resistors and COG/NP0 or electrolytic capacitors are recommended

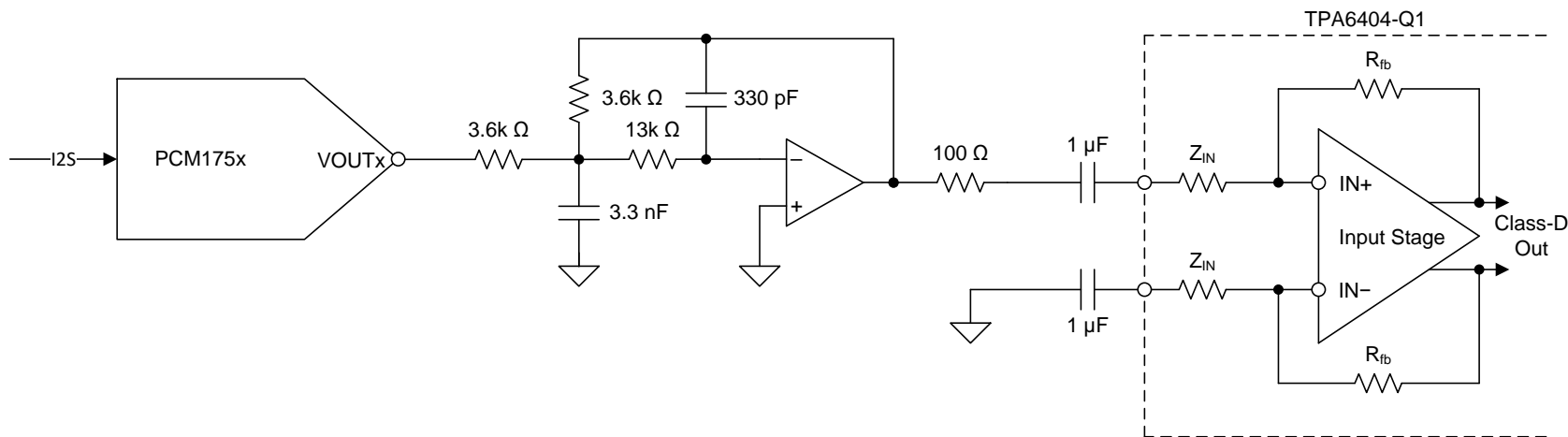

# Selecting Discrete SMT Components

- Generally COG/NP0 are recommended for AC signal path components
- X7R, other ceramics are preferred for DC decoupling (bypass caps)

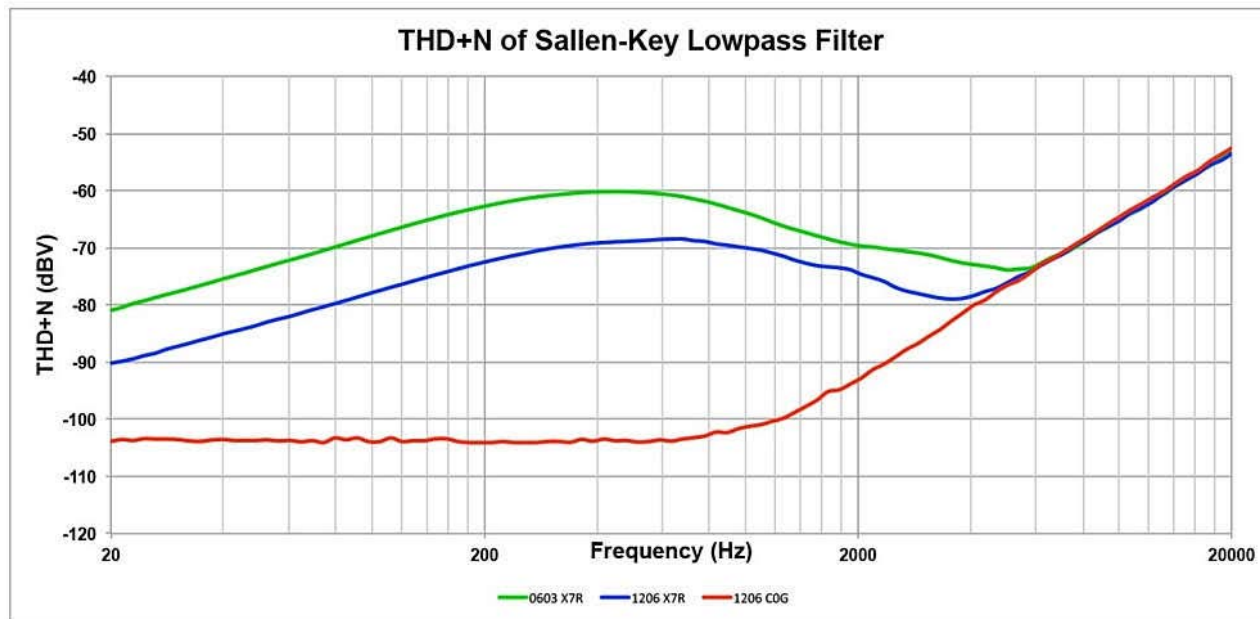

\*EDN

# PCM5102A

2VRMS, 2 Channel, Direct Path™, 112/106/100dB Audio Stereo DAC with 32-bit, 384kHz PCMI

## Features

- Next Gen Advanced Current Segment Architecture
- Up to 112dB Dynamic Range in p/p packages Integrated PLL
- Advanced Mute Circuitry with integrated UVP
- Clock halt detect circuitry detects errors in BCK & MCLK
- Single 3.3V power supply, with Directpath™ output amplifier
- Automotive Qualified

## Benefits

- Ultra low out of band noise and jitter suppression
- Single design, multiple product spins
- No need to layout high speed clocks on the PCB (e.g. 24.567MHz). Automatic sampling frequency detection.
- Zero Pop and Click with soft mute and analog mute.
- Zero Pop and Click on source switch (e.g. ADC to HDMI) Auto-power down by stopping clocks saves GPIO.
- Ground biased output required no DC blocking cap, or external mute circuit.

## Applications

- TV: CRT
- TV: LCD/Digital
- Blu-ray Player
- Mini-Micro combo systems
- Set-Top Box (STB)
- Soundbar

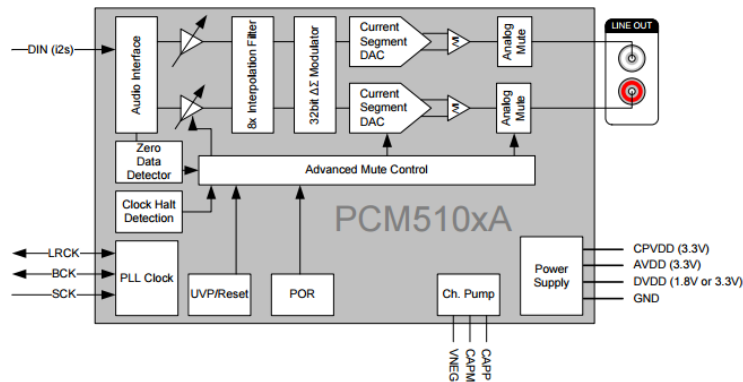

# Difference in Low Cost DACs

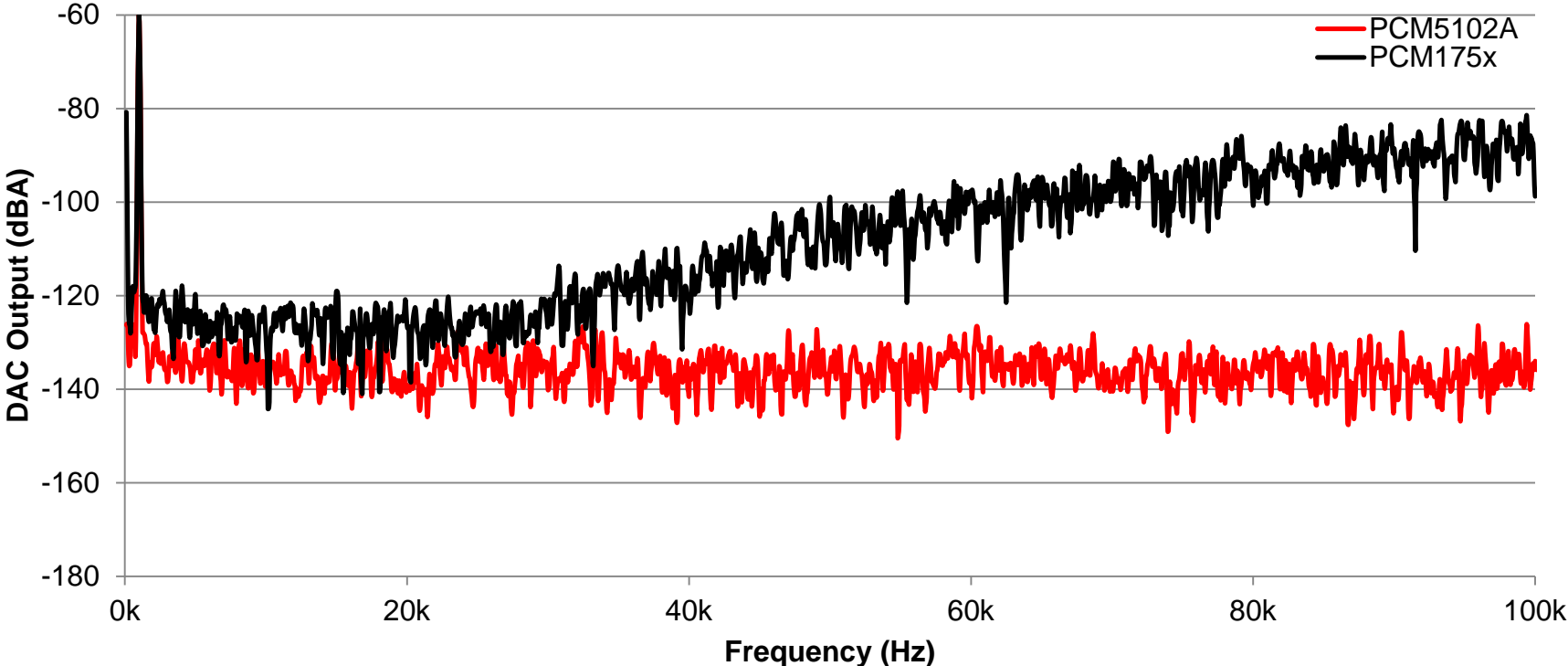

# PCM510xA With The TPA6404-Q1

- $f_c = 153\text{kHz}$  passive RC filter
- DC blocking caps used with input impedance for HPF as recommended for the TPA6404-Q1
- Thin film resistors and COG/NP0 or electrolytic capacitors are recommended

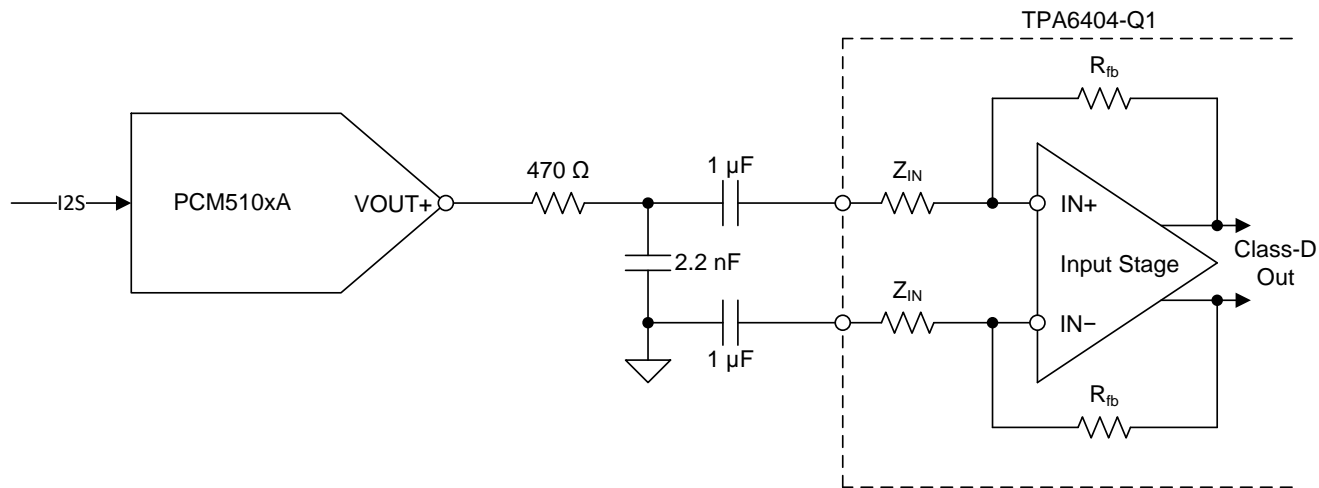

# PCM5242

## Differential output DAC with open processing capability

### Features

- Up to 114dB Dynamic Range
- Fully programmable miniDSP (PCM5252 Features SmartAmp)
- Differential drive for best CMRR with in-system amplifier
- Advanced mute circuitry with clock error and UVP detection
- Integrated Audio PLL
- Single 3.3V power supply w/ DirectPath™

### Applications

Consumer Audio Electronics  
Pro Audio  
Automotive

### Benefits

- Superb performance
- Graphically programmable audio processing for the best audio experience
- Best performance and noise cancellation
- Soft volume ramp and analog mute
- Run from non-audio clock sources
- Ground biased output requires no DC Blocking Caps

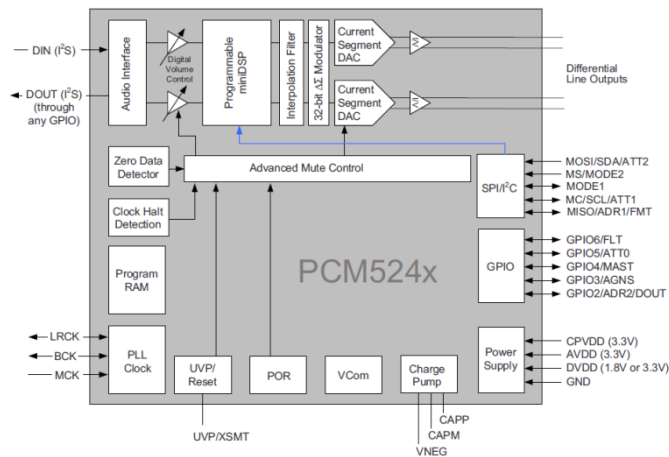

# PCM5242/52 Differential Output

- DC blocking caps used with input impedance for HPF as recommended for the TPA6404-Q1
- Thin film resistors and COG/NP0 or electrolytic capacitors are recommended
- $f_c = 153\text{kHz}$  passive RC filter

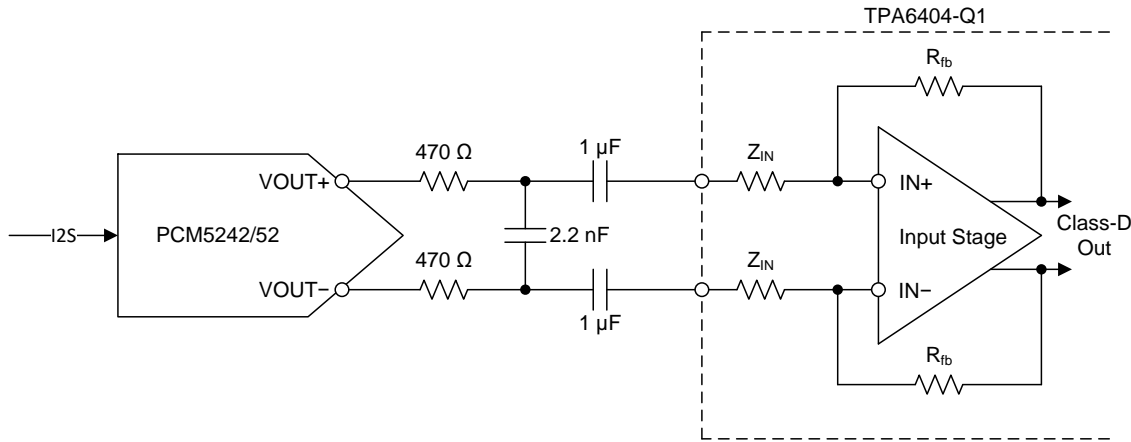



# Using the TPA6404-Q1

# Amplifier Schematic

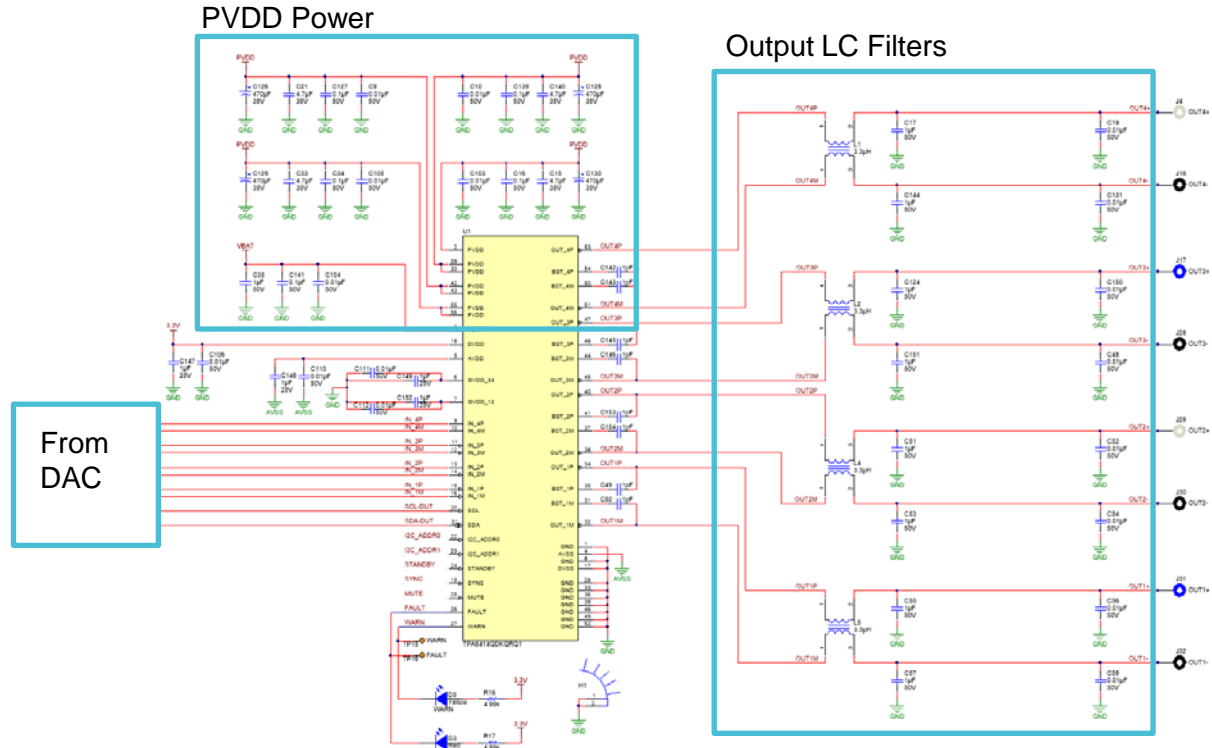

# Where THD comes from?

- Internal amplifier non-linearity
- PWM generator
- Gate driver dead time
- External component non-linearity

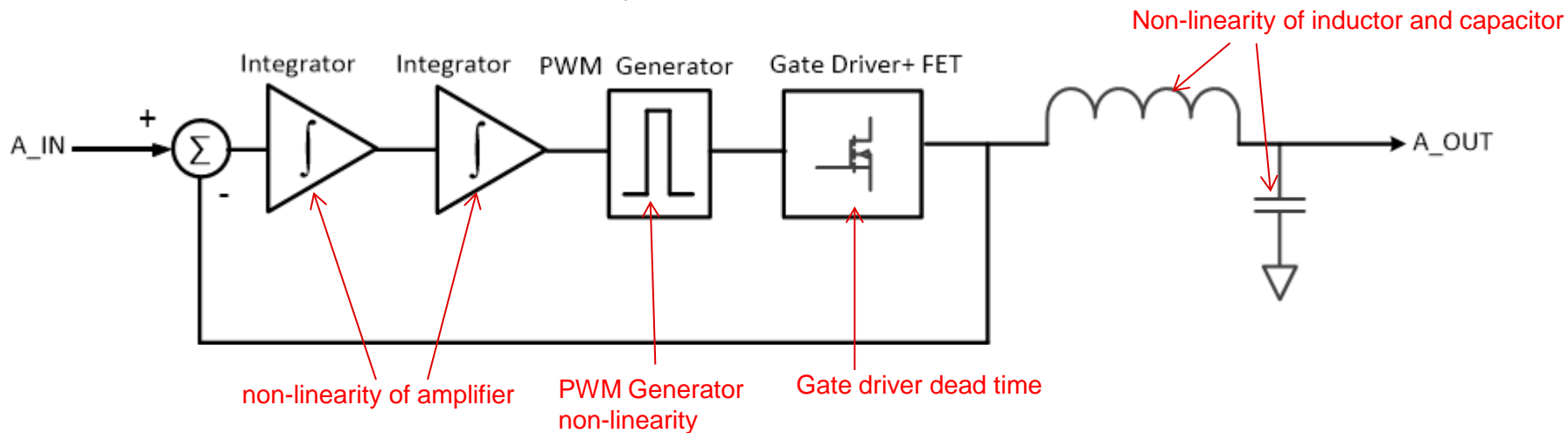

# How does 2.1MHz improves THD

- Simply the model
  - Gain A is PWM and gate driver
  - Distortion D is simplified in-loop distortion

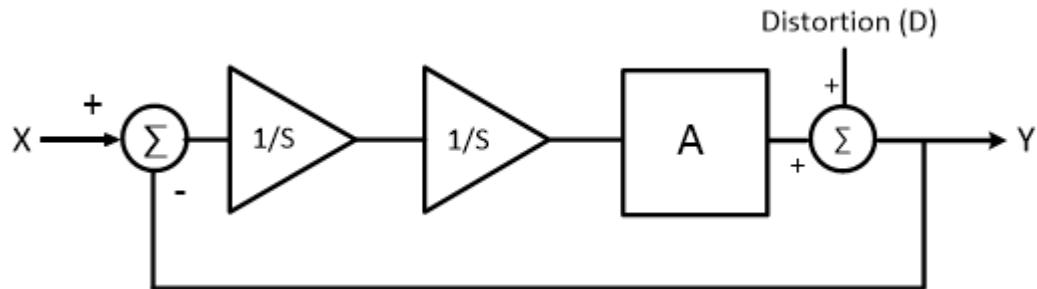

- Signal transfer function is:

$$Y = \frac{A}{S^2 + A} * X$$

- Distortion transfer function is:

$$Y = \frac{S^2}{S^2 + A} * D$$

# How does 2.1MHz improves THD

- With distortion transfer function, distortion is moved to high frequency range. The higher loop bandwidth, the lower THD left in audio band.

**Traditional 400K switching**  
Loop bandwidth: 70KHz

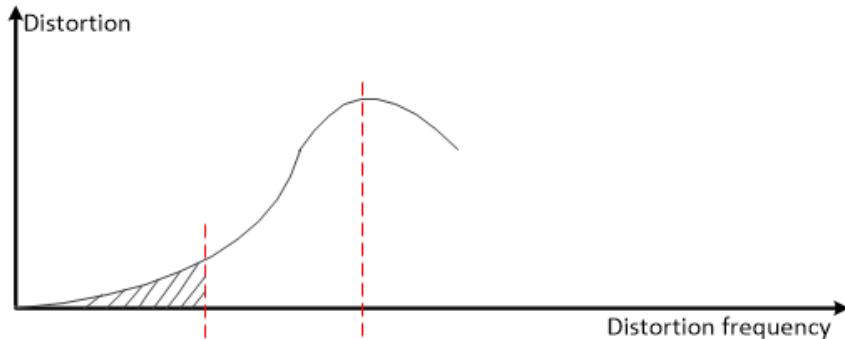

$$Y = \frac{S^2}{S^2 + A} * D$$

**TI 2.1MHz switching**  
Loop bandwidth: 300KHz

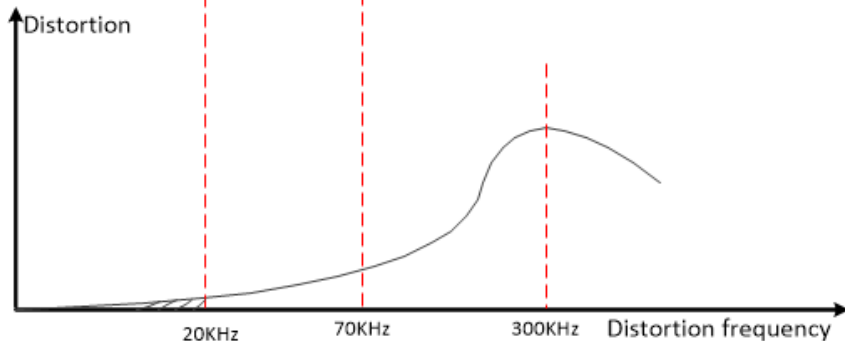

# How does 2.1MHz improves IMD

- What is IMD (intermodulation distortion)

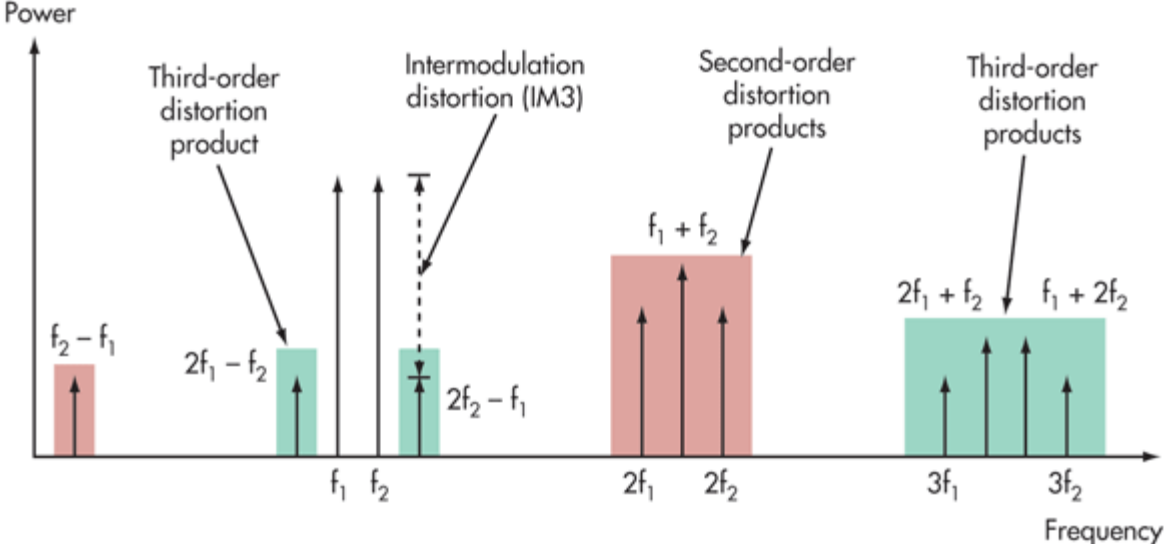

# How does 2.1MHz improves IMD

- A typical THD vs F graph, THD over 6.7KHz is very low, but in fact it is dot line as below

**Traditional 400K switching**  
Loop bandwidth: 70KHz

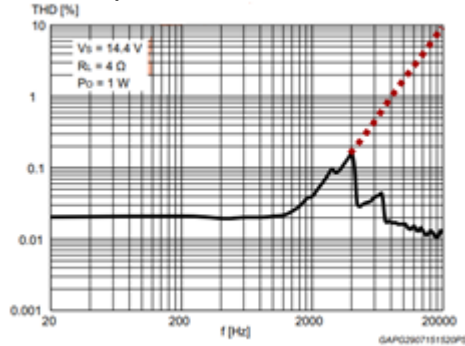

**TI 2.1MHz switching**  
Loop bandwidth: 300KHz

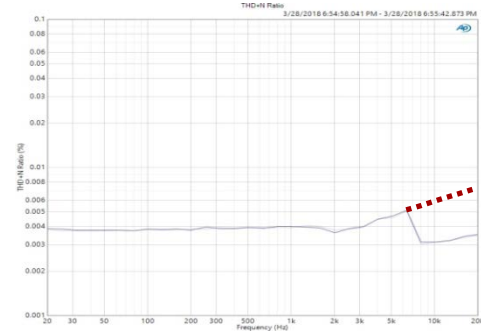

- IMD of 1KHz and 18KHz would be

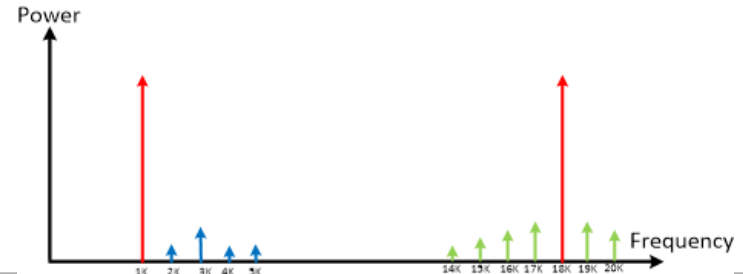
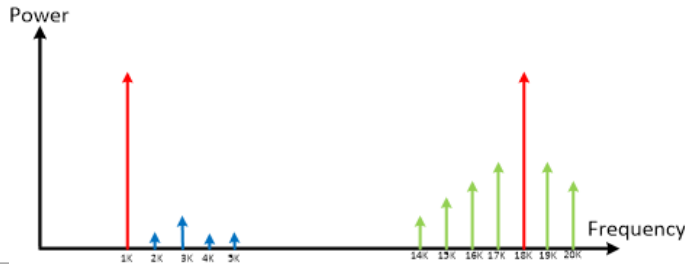

# Example Design

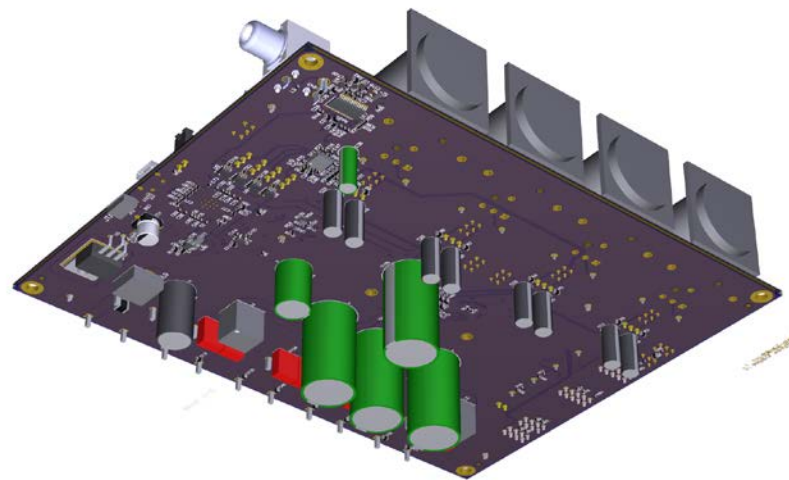
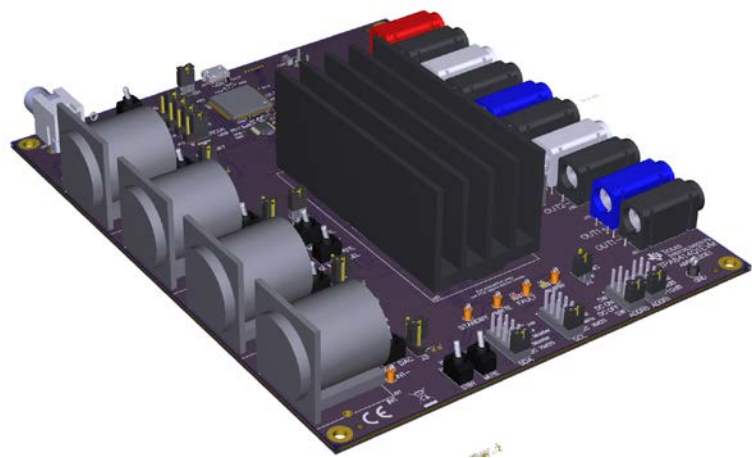



# PVDD and VBAT Power

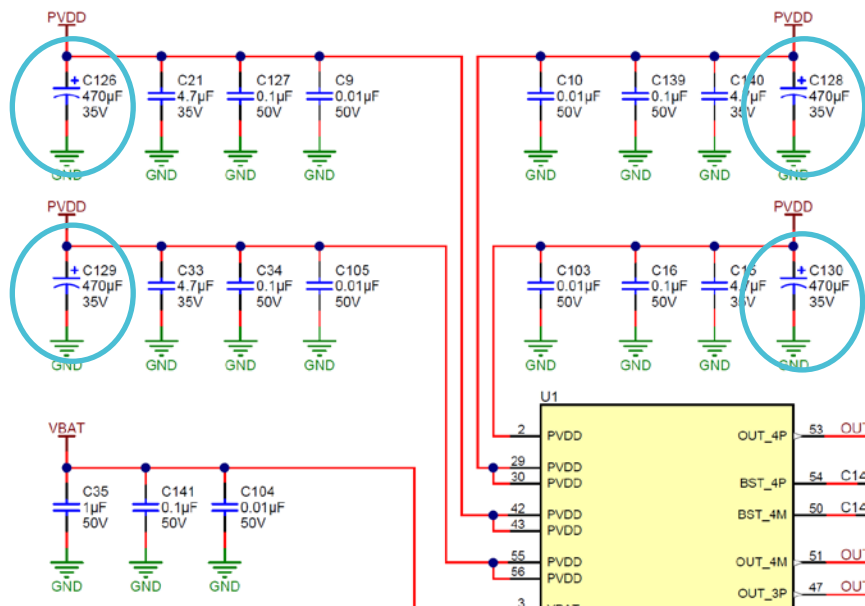

- Use many bulk caps, one at each set of PVDD pins
  - This provides a much more stable PVDD under dynamic current demand in the audio band.
  - This improves THD and IMD by not allowing the power supply to modulate with audio.

# PVDD and VBAT Power

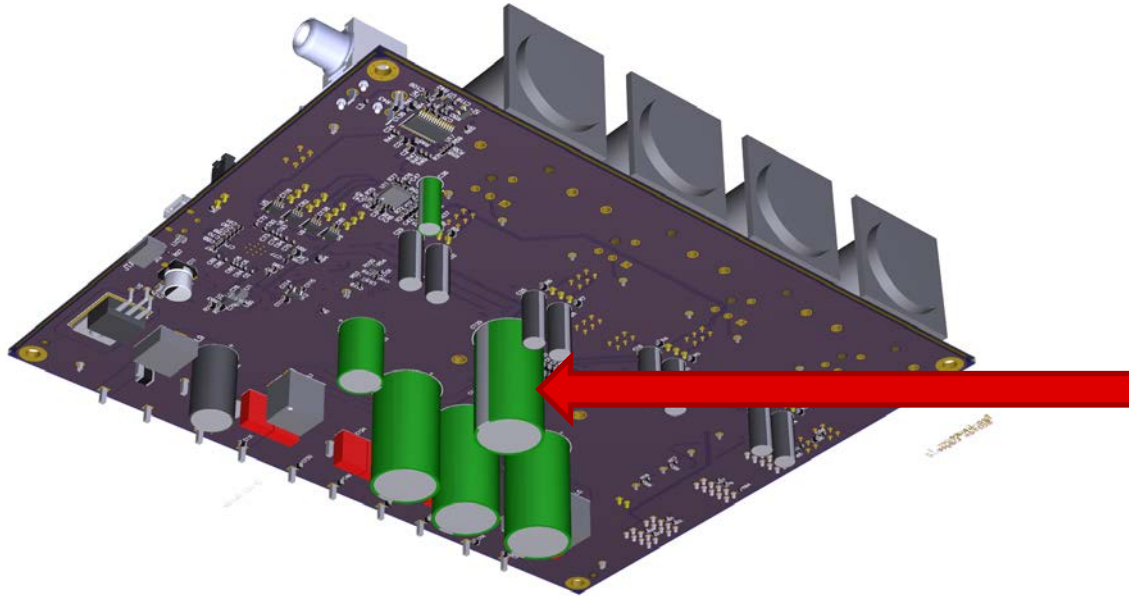

Special audio grade  
electrolytics

# Output LC Filter

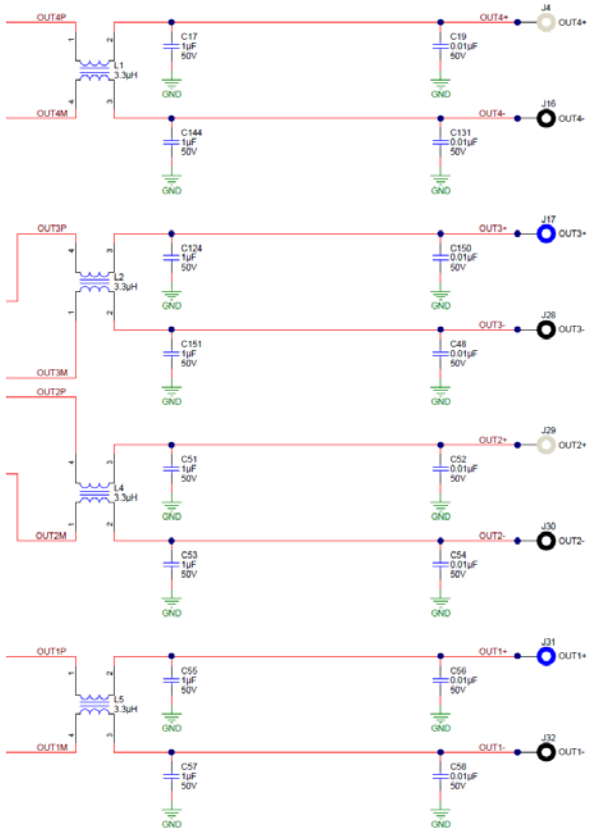

- Use Film capacitors for the main filter capacitor
  - Film capacitors are stable over voltage
  - This provides improved IMD
- Use High quality Ferrite inductors that have high linearity over frequency and temperature.
- Wide bandwidth allows for zero phase change in the audio band for good group delay
- By having the wide bandwidth the filter Q phase change does not impact the audio band

# Output LC Filter

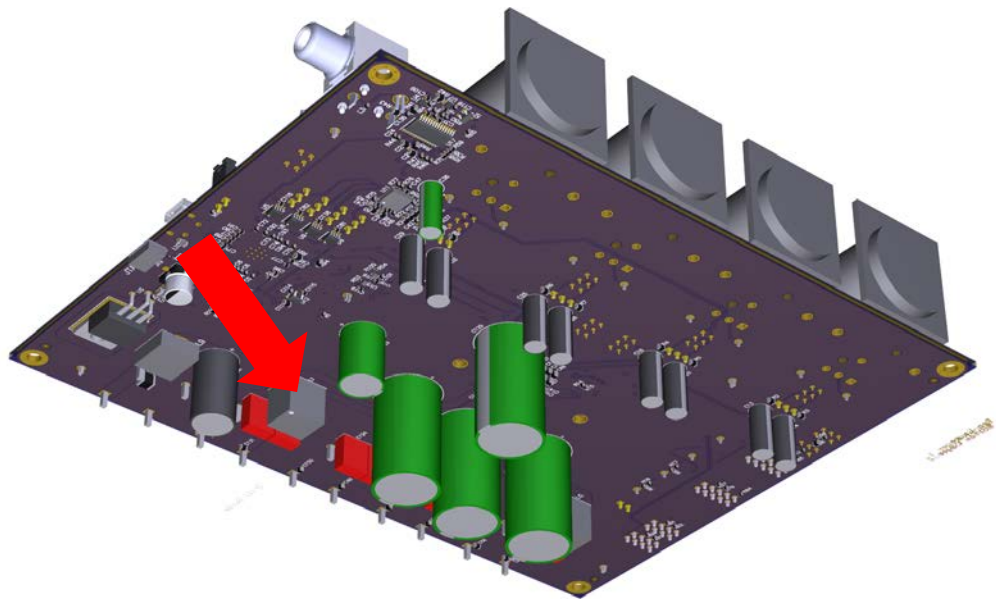

- Film capacitors (red boxes) provide much better THD
- High quality ferrite inductor indicated by arrow for improved THD
- For improved common mode the layout should have the film caps grounds near each other.

# Key market differentiators

- 2.1MHz PWM switching to improve THD and IMD
- DACs with low out of band noise for simple RC filter without introducing an OPAMP
- Balanced outputs and inputs allow for improved common-mode rejection and noise.

# Customer collateral

The following information is available for you to send for customers

Content type	Content title	Link to content or more details
Customer training series or webinar session	Measuring Class-D Audio Performance	<a href="#">Link</a>
Technical blog content or white paper	Why you should switch a to Class-D Amp	<a href="#">Link</a>
	How Switching above the AM Band eases automotive Class-D amplifier EMC design	<a href="#">Link</a>
	Forget the tiny homes craze, Have you heard about tiny inductors for automotive class d amplifiers?	<a href="#">Link</a>
	Dynamic Performance Testing of Digital Audio D/A Converters	<a href="#">Link</a>
	Using the TAS5754/6M and PCM5242 Hybrid Processor – User’s Guide	<a href="#">Link</a>
	Signal Distortion From High-K Ceramic Capacitors	<a href="#">Link</a>



© Copyright 2018 Texas Instruments Incorporated. All rights reserved.

This material is provided strictly “as-is,” for informational purposes only, and without any warranty.  
Use of this material is subject to TI’s **Terms of Use**, viewable at [TI.com](https://www.ti.com)

# Designing a Premium Automotive Audio System

PCM5242+PCM510xA+TPA6404-Q1 allows for 2.2 configuration (4x BTL) or 2.1 configuration (2x BTL, 1x PBTL)

- miniDSP allows for digital crossover, bassboost, DRC, etc.
- GPIO can be configured for data output for additional non-DSP DAC

