

How to Choose a Shunt Resistor

TI Precision Labs – Current Sense Amplifiers

Presented by Rajani Manchukonda

Prepared by Ian Williams and Rabab Itarsiwala

Hello, and welcome to the TI precision labs series on current sense amplifiers. My name is Rajani Manchukonda, and I'm a product marketing engineer for current sensing products. In this video, we will look into the primary factors that impact the choice of shunt resistor, and show how to calculate the maximum shunt resistor value for an application. We will also briefly touch upon shunt resistor tolerance error.

What is a shunt resistor?

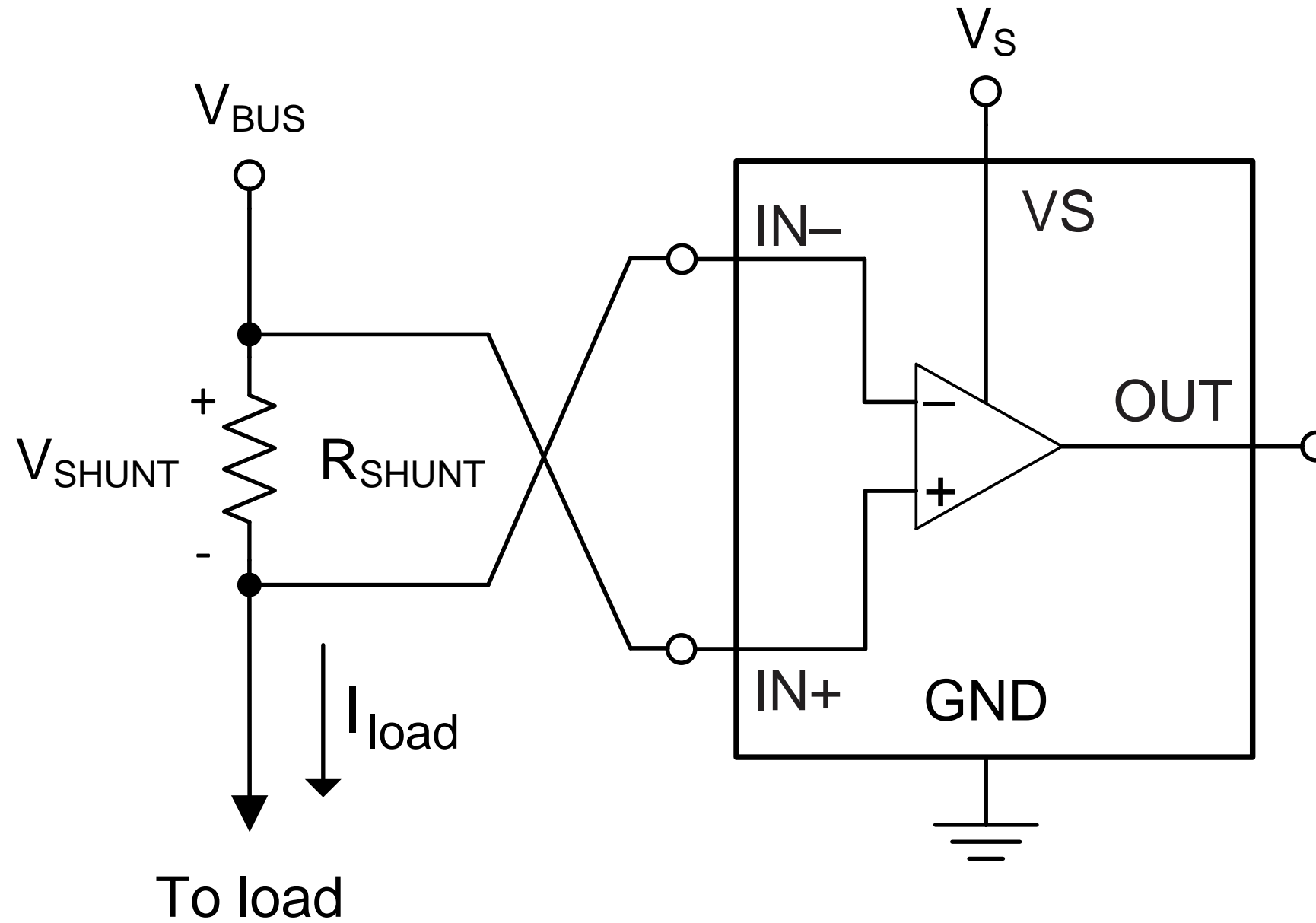

First, let's define a shunt resistor, or RSHUNT. This is the resistor through which load current flows in a current sensing application. Due to Ohm's law, a differential voltage called VSHUNT or VSENSE is developed across RSHUNT, which is then measured by a differential amplifier like a current sense amplifier.

Primary factors for choosing a shunt resistor

1. Minimum current accuracy
2. Maximum power dissipation
 - Size
 - Cost



Shunt resistor examples

Selecting the value of RSHUNT is based primarily on 2 factors:

1. The required accuracy at minimum load current, and
2. The power dissipation at maximum load current, with its associated size and cost.

Minimum current accuracy

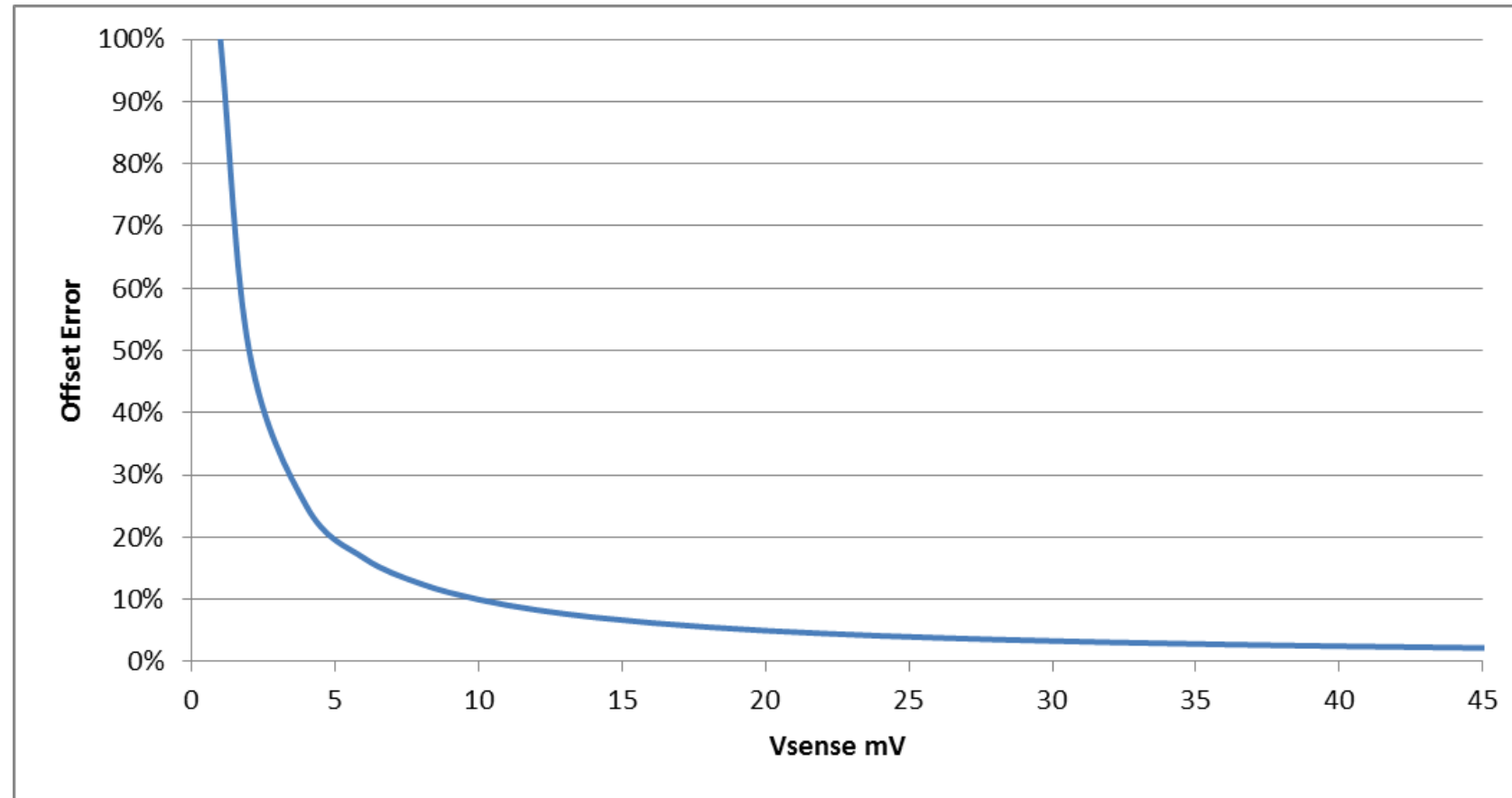

$$\text{Offset error (\%)} = \left(\frac{V_{os}}{V_{sense}} \right) * 100$$

$$V_{sense} = R_{shunt} * I_{load}$$

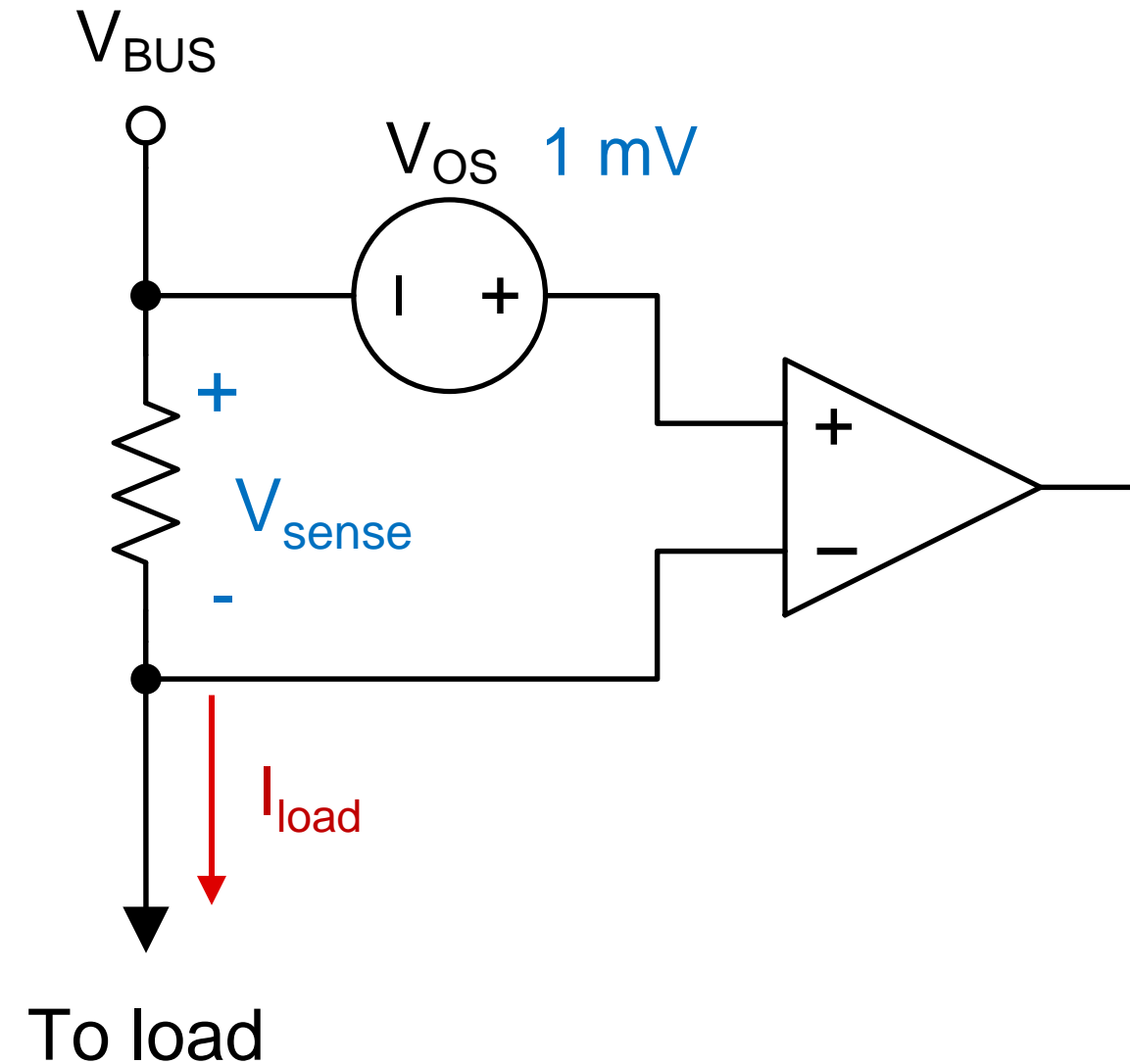

Now let me explain how to determine minimum current accuracy for a current sensing application. For simplicity, we will only consider the amplifier's offset error in this case and ignore other error sources which will be discussed in later videos.

Amplifier input offset voltage, or VOS, is the dominant source of error at low load currents, and therefore low sense voltages. The plot on the left shows that offset error decreases as VSENSE increases. The larger the voltage developed across the shunt resistor, the more accurate of a measurement can be made due to the fixed nature of VOS. Said another way, this fixed internal amplifier error results in a larger uncertainty as the input signal gets smaller.

Let's look at this in some more detail, using a theoretical current sense amplifier with VOS equal to 1 millivolt.

Minimum current accuracy

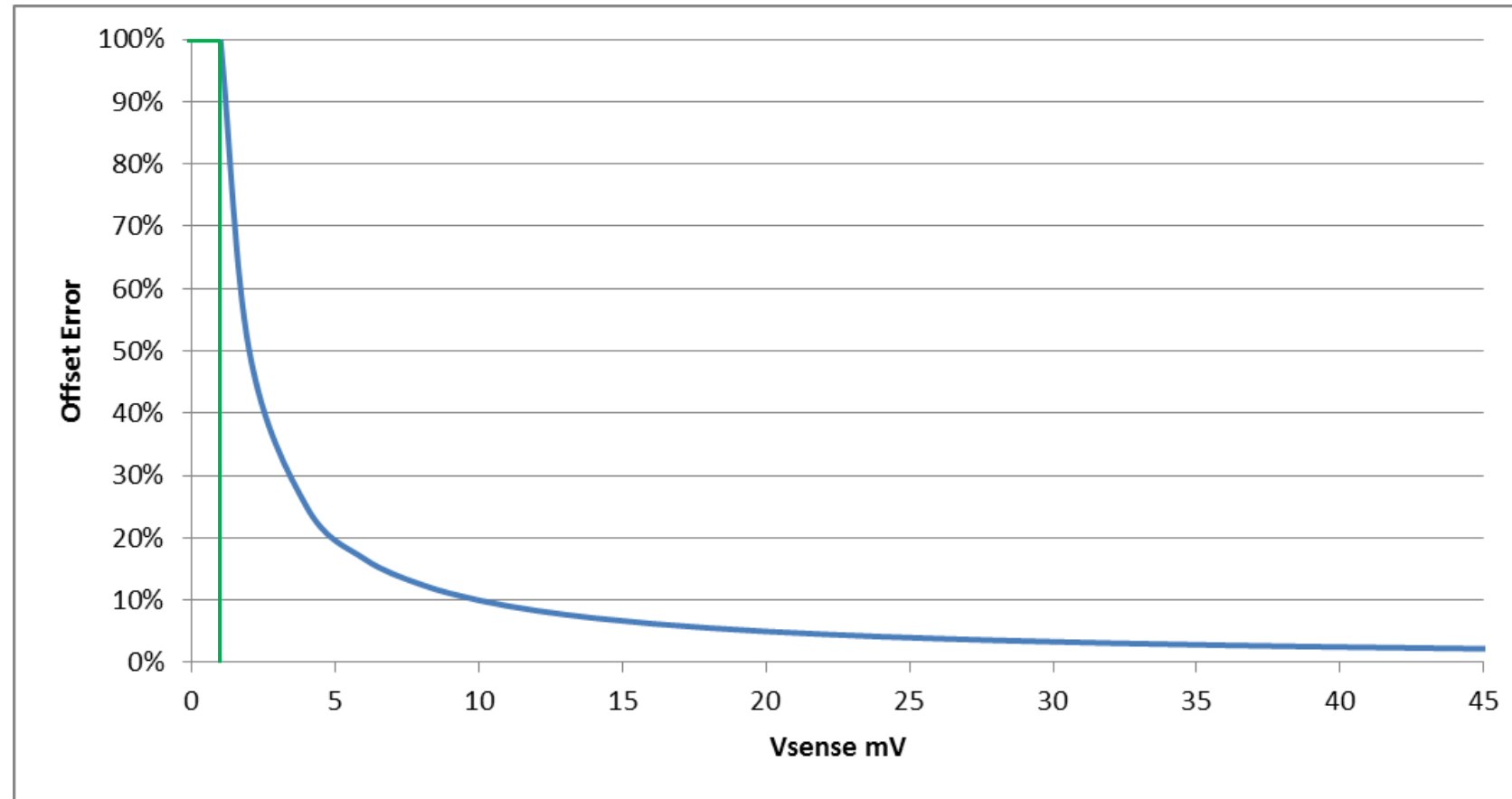

$$\text{Offset error (\%)} = \frac{1 \text{ mV}}{1 \text{ mV}} * 100 = 100 \%$$

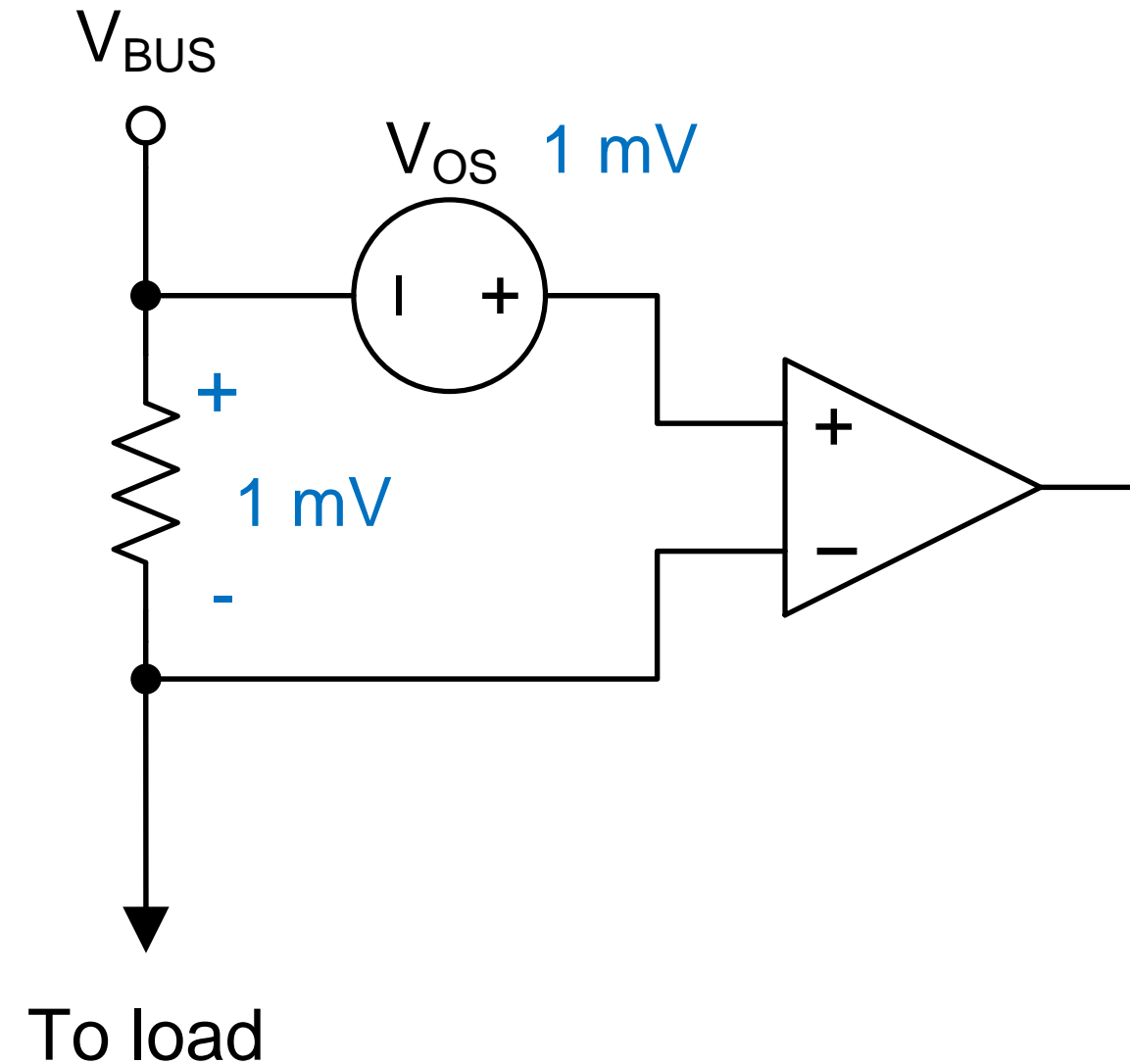

When V_{SENSE} is equal to V_{OS} at 1mV, the uncertainty of measurement is 100%, as shown in the plot and the offset error calculation.

Minimum current accuracy

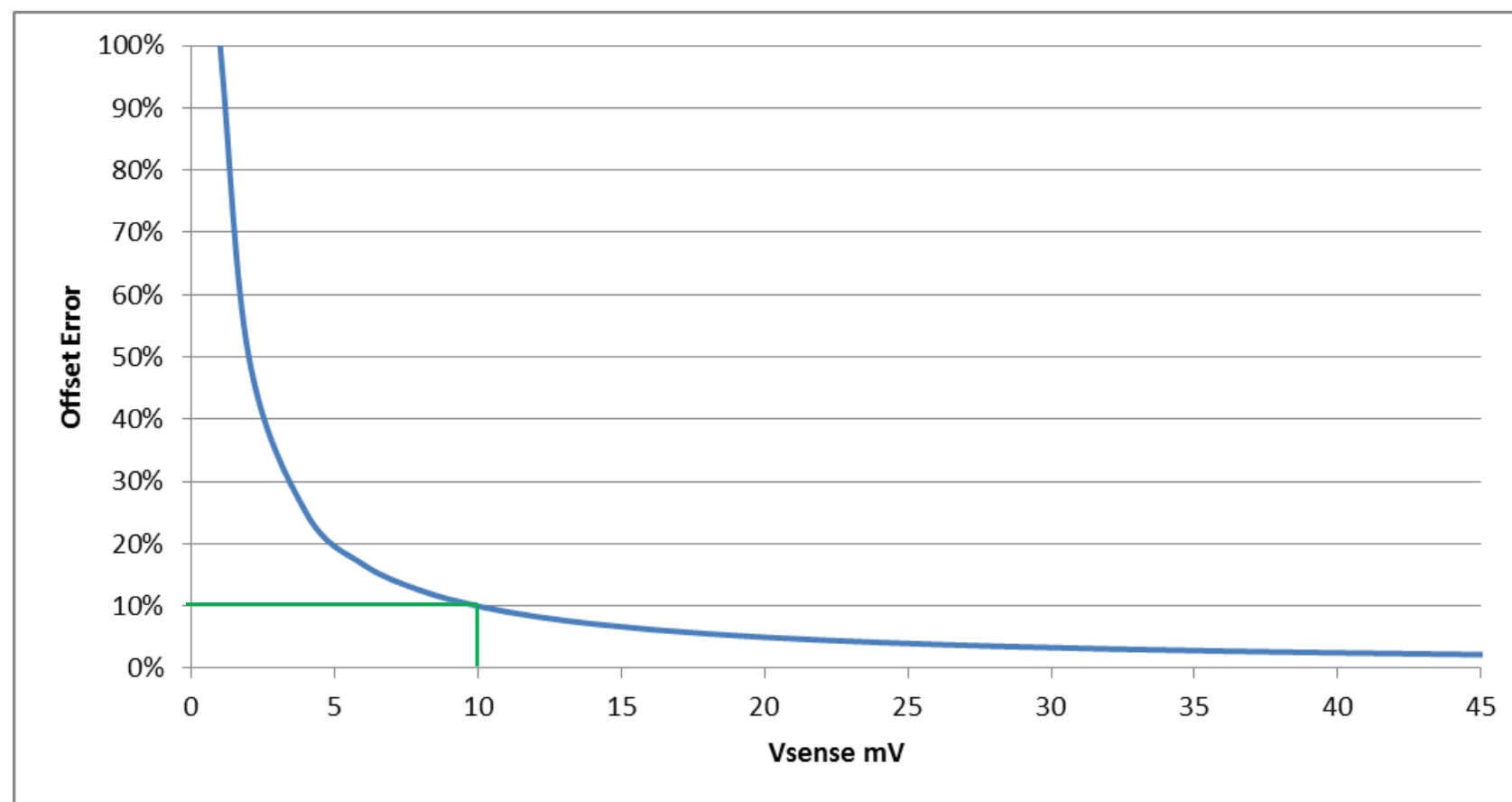

$$\text{Offset error (\%)} = \frac{1 \text{ mV}}{10 \text{ mV}} * 100 = 10 \%$$

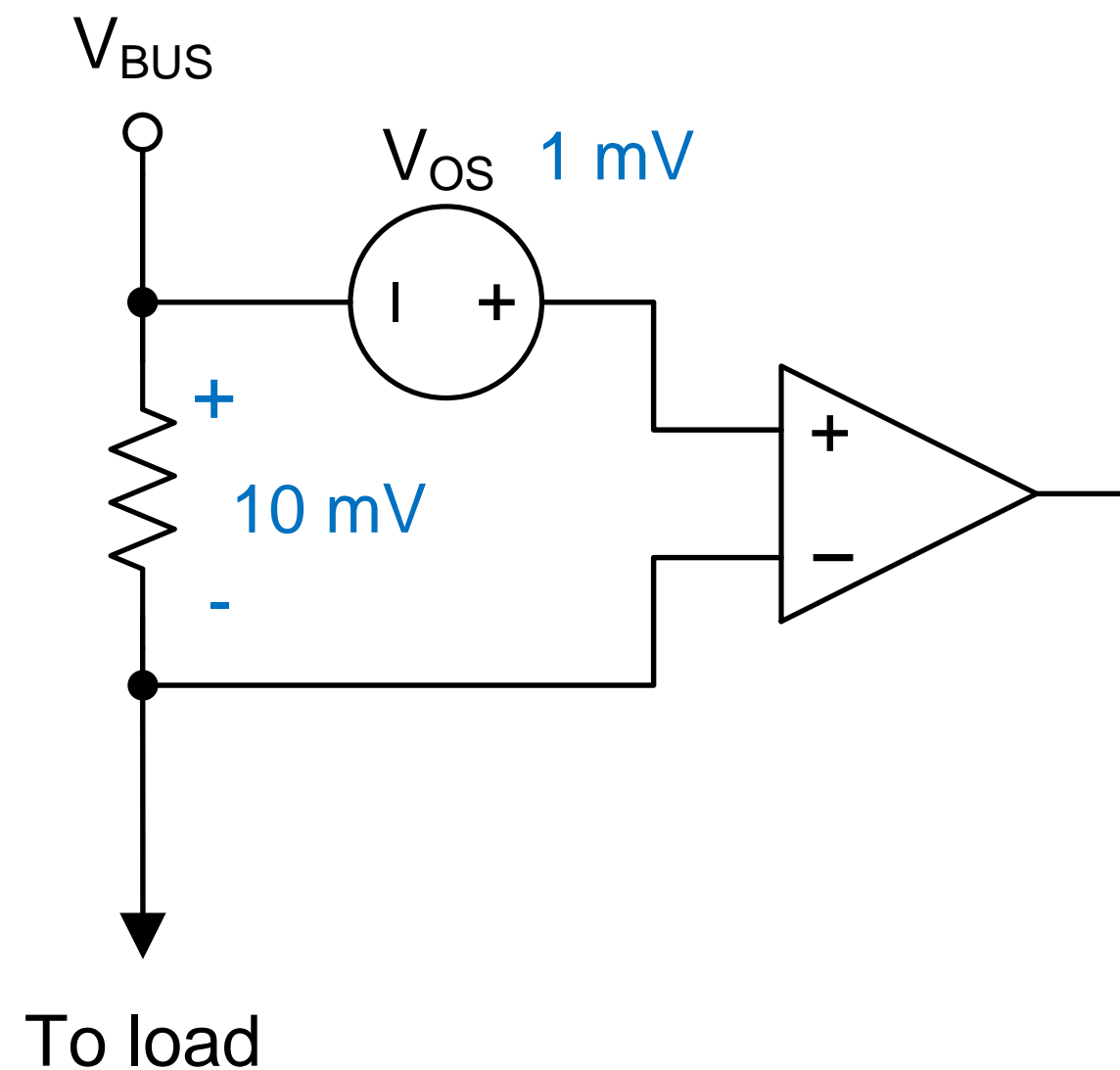

When V_{SENSE} is increased to 10 mV, the measurement error drops significantly, to 10%. Now that we understand the dominant constraint at minimum current due to VOS errors, let's consider what happens at maximum current.

Maximum current power dissipation

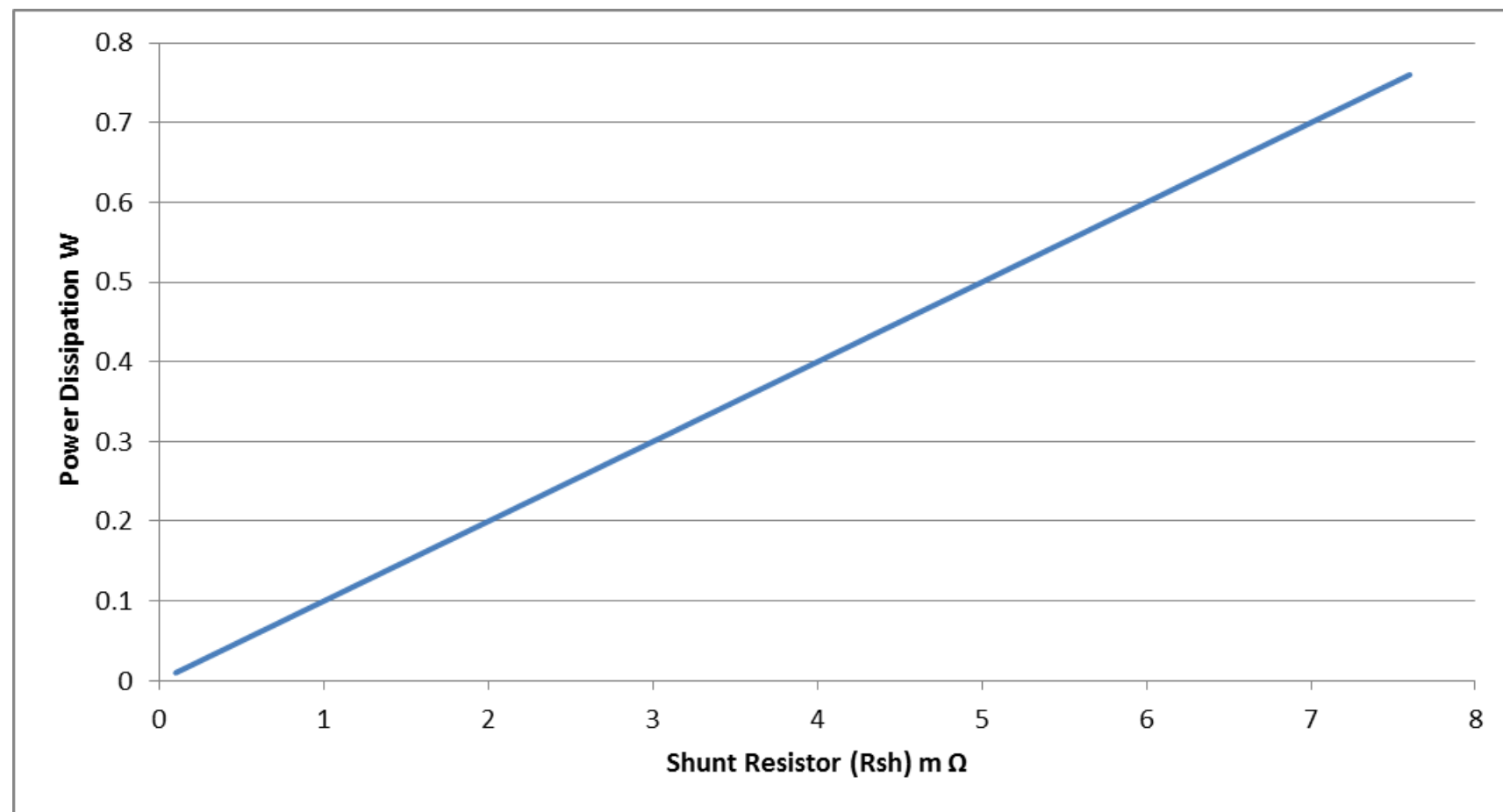

$$\text{Power dissipation (W)} = R_{\text{shunt}} * I_{\text{load}}^2$$

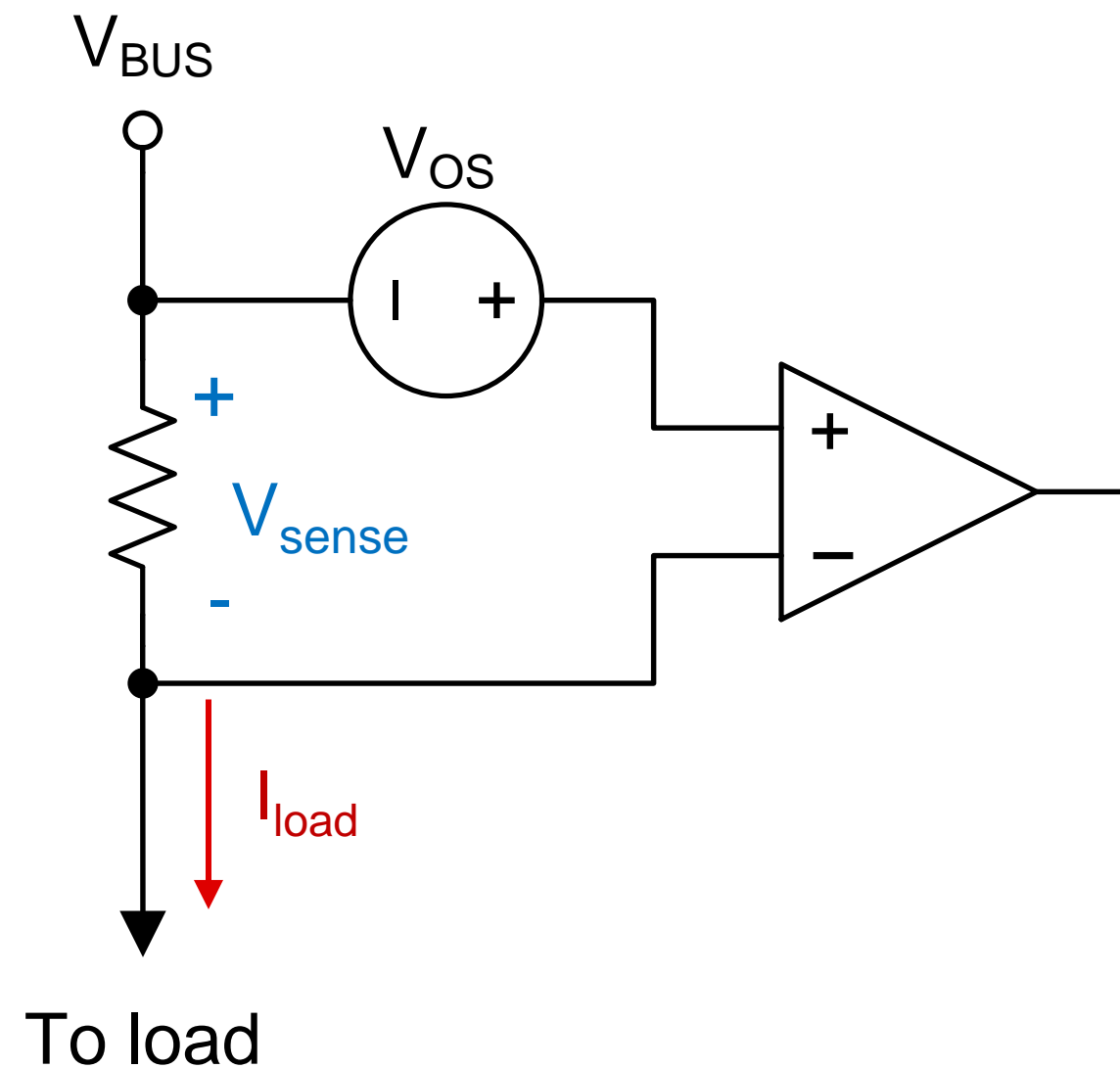

On the left is a plot of power dissipation vs shunt resistance for a fixed load current. Power dissipation in the shunt resistor is the product of voltage across it and current flowing through it, or equivalently, the product of the shunt resistance and square of the current flowing through it. Increasing the value of the current-shunt resistor increases the differential voltage developed across the resistor, reducing errors caused by VOS. However, the power that is dissipated across the shunt resistor also increases, which can cause heat, size, and cost problems in a real application.

Power dissipation vs. minimum current accuracy

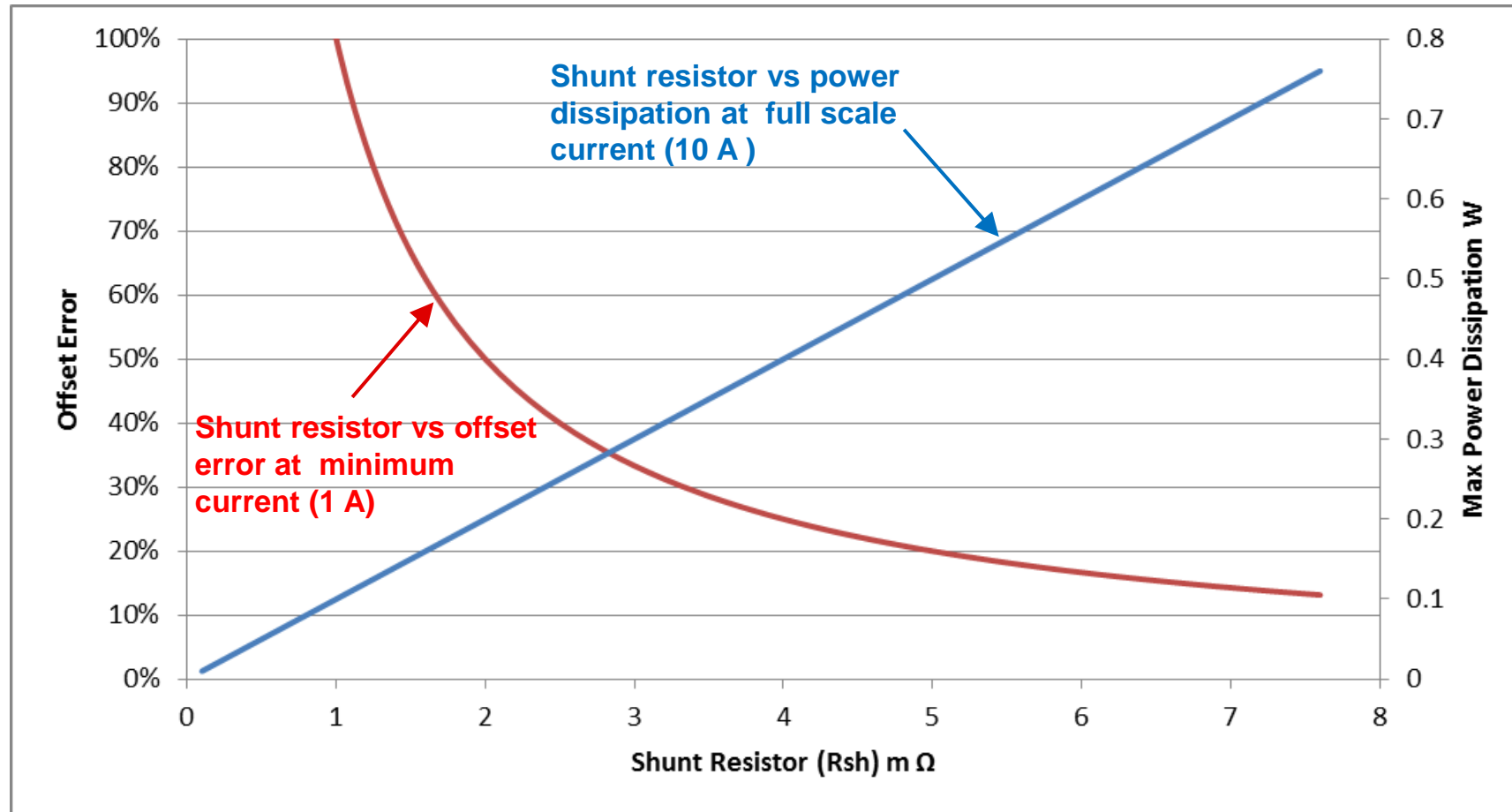

$$\text{Offset error (\%)} = \frac{V_{os}}{R_{shunt} * I_{load_min}} * 100$$

$$\text{Max power dissipation (W)} = R_{shunt} * I_{load_max}^2$$

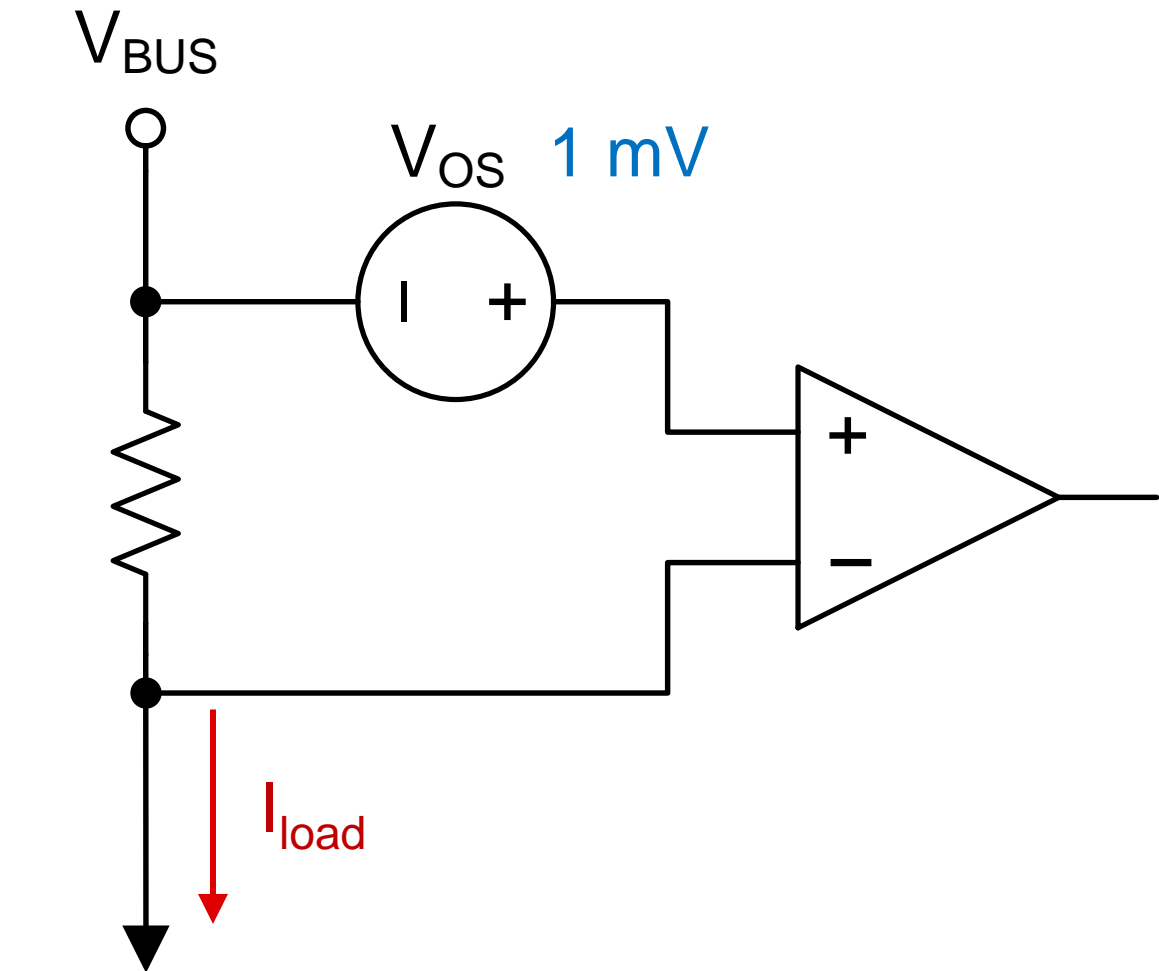

To load

$$I_{load_min} = 1 \text{ A}; I_{load_max} = 10 \text{ A}$$

There is a tradeoff between maximizing accuracy at minimum current, and minimizing power dissipation at maximum current.

Consider an application with a minimum current of 1A and a maximum current of 10A, and our amplifier with $V_{OS} = 1\text{mV}$. The red plot shows the variation in the offset error at minimum current vs shunt resistance for this application. The blue plot shows the variation in power dissipation at maximum current versus shunt resistance.

What we can see here, is increasing the shunt resistor value improves current accuracy but also increases power dissipation. Decreasing the value of the current-shunt resistor reduces the power dissipation requirements, but increases the measurement errors. Finding the optimal value for the shunt resistor requires factoring both the accuracy requirement of the application and allowable power dissipation into the selection of the resistor.

Lets continue working through this example.

Power dissipation vs. minimum current accuracy

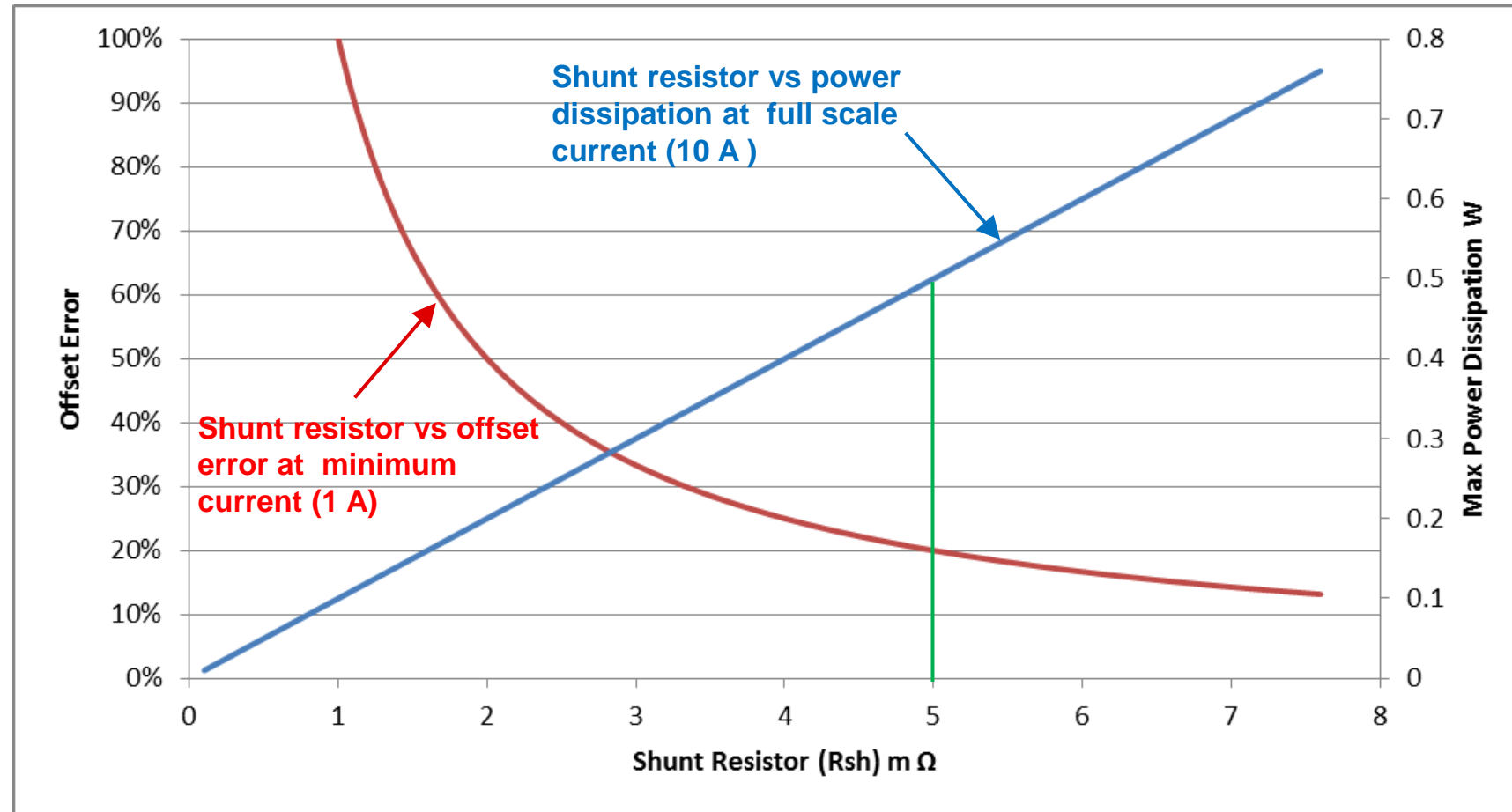

$$\text{Offset error (\%)} = \frac{1 \text{ mV}}{5 \text{ m}\Omega * 1 \text{ A}} * 100 = 20 \%$$

$$\text{Max power dissipation (W)} = 5 \text{ m}\Omega * 10 \text{ A}^2 = 0.5 \text{ W}$$

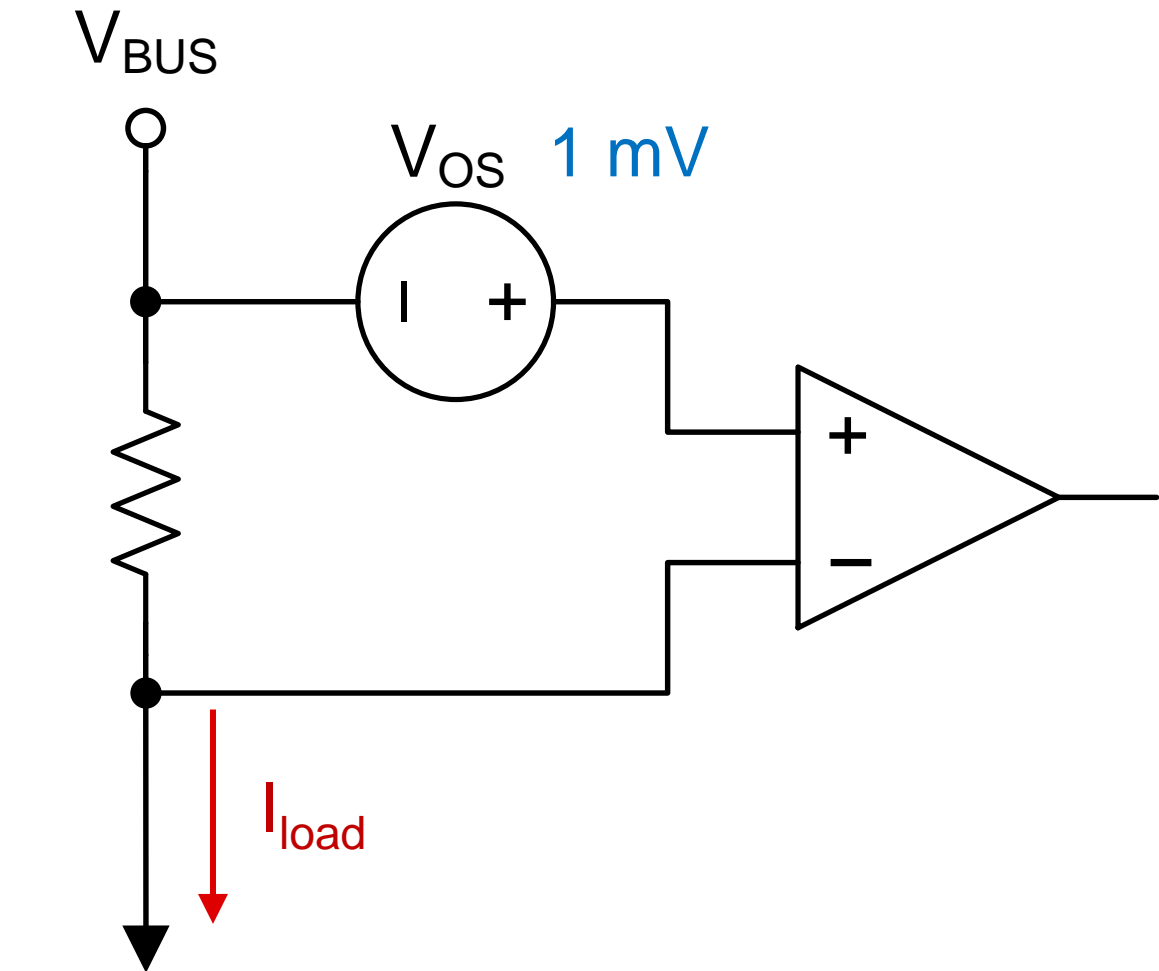

To load

$$I_{load_min} = 1 \text{ A}; I_{load_max} = 10 \text{ A}$$

If a 5 milli-ohm resistor is chosen for this application...

Power dissipation vs. minimum current accuracy

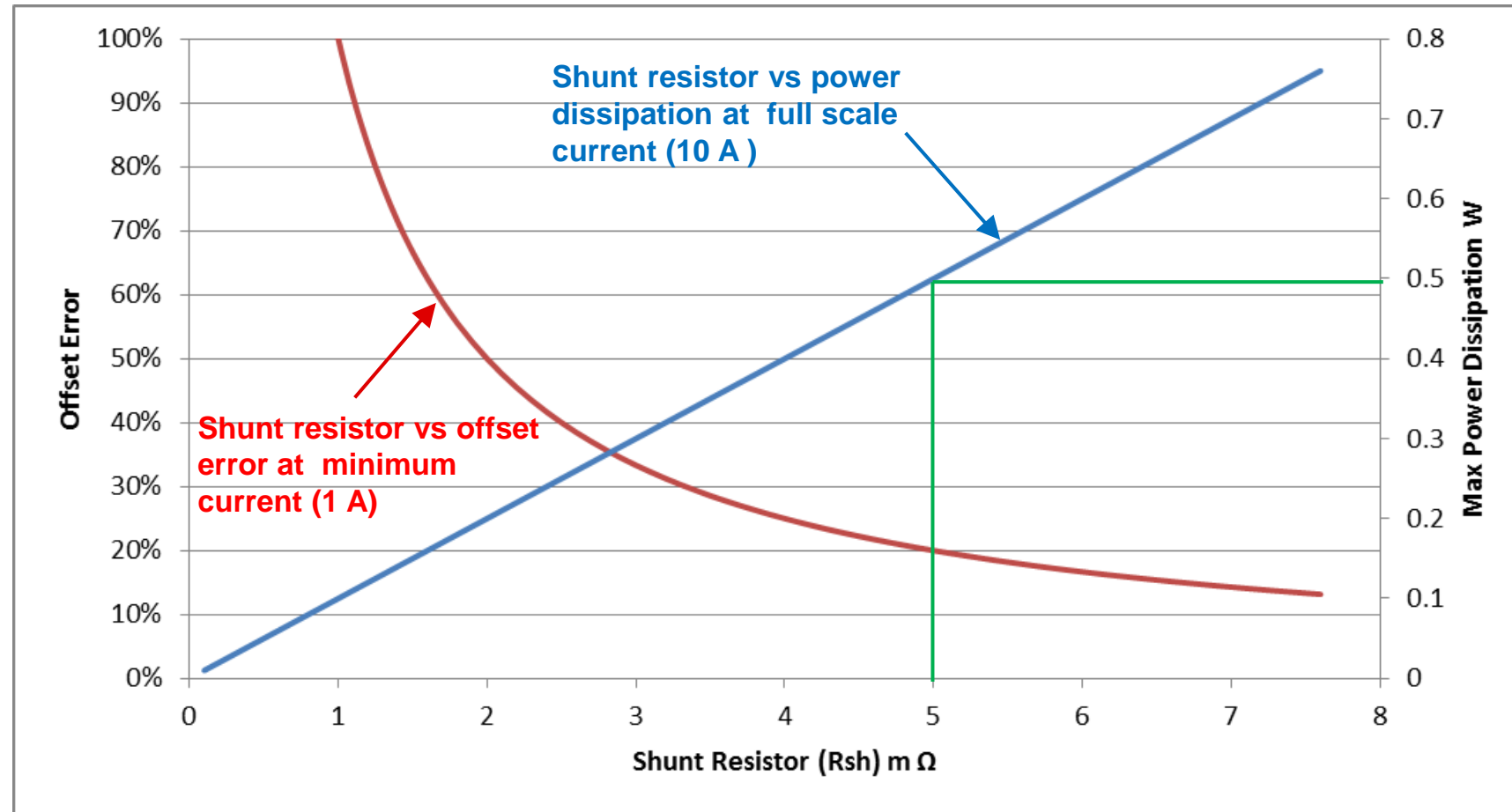

$$\text{Offset error (\%)} = \frac{1 \text{ mV}}{5 \text{ m}\Omega * 1 \text{ A}} * 100 = 20 \%$$

$$\text{Max power dissipation (W)} = 5 \text{ m}\Omega * 10 \text{ A}^2 = 0.5 \text{ W}$$

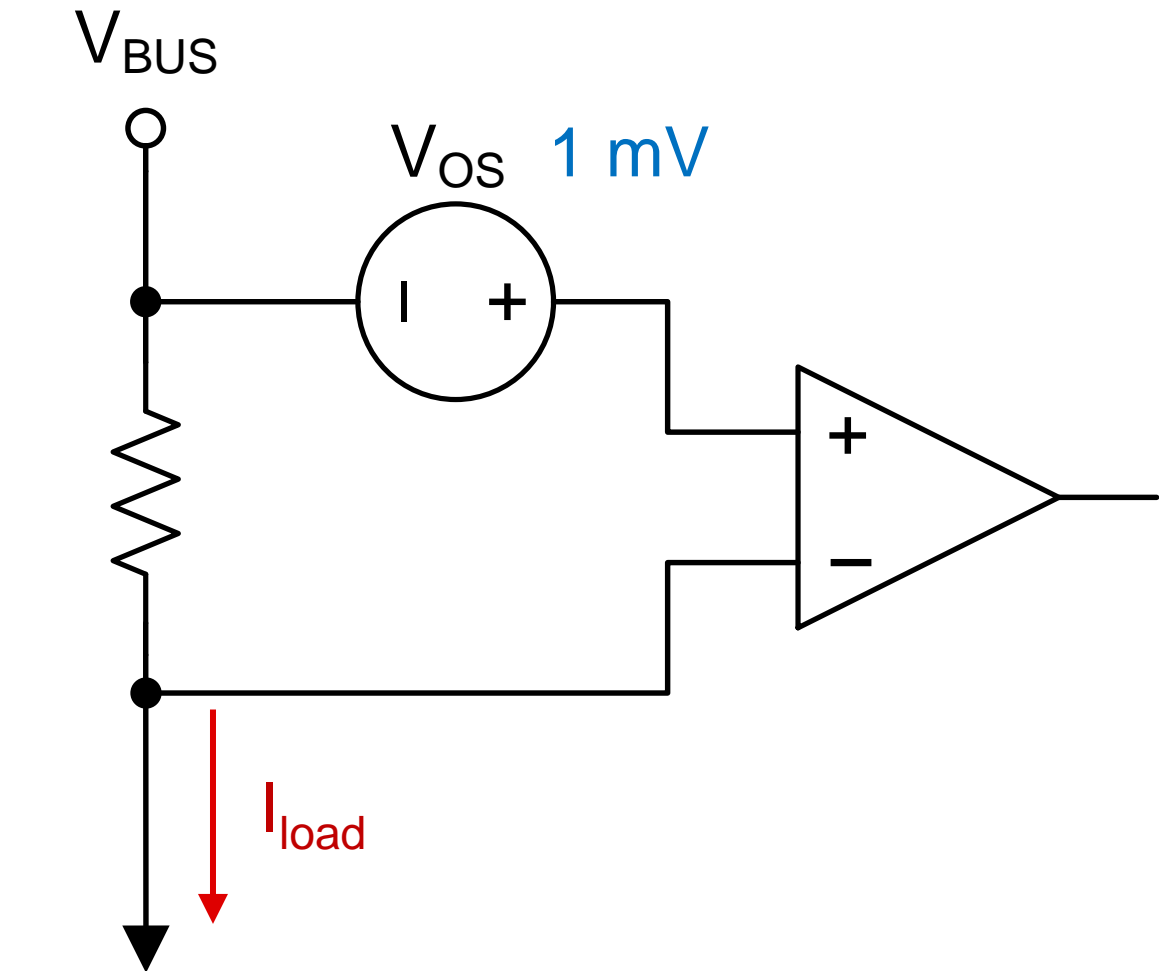

To load

$$I_{load_min} = 1 \text{ A}; I_{load_max} = 10 \text{ A}$$

...the power dissipation at maximum load current of 10 A will be about 0.5 watts...

Power dissipation vs. minimum current accuracy

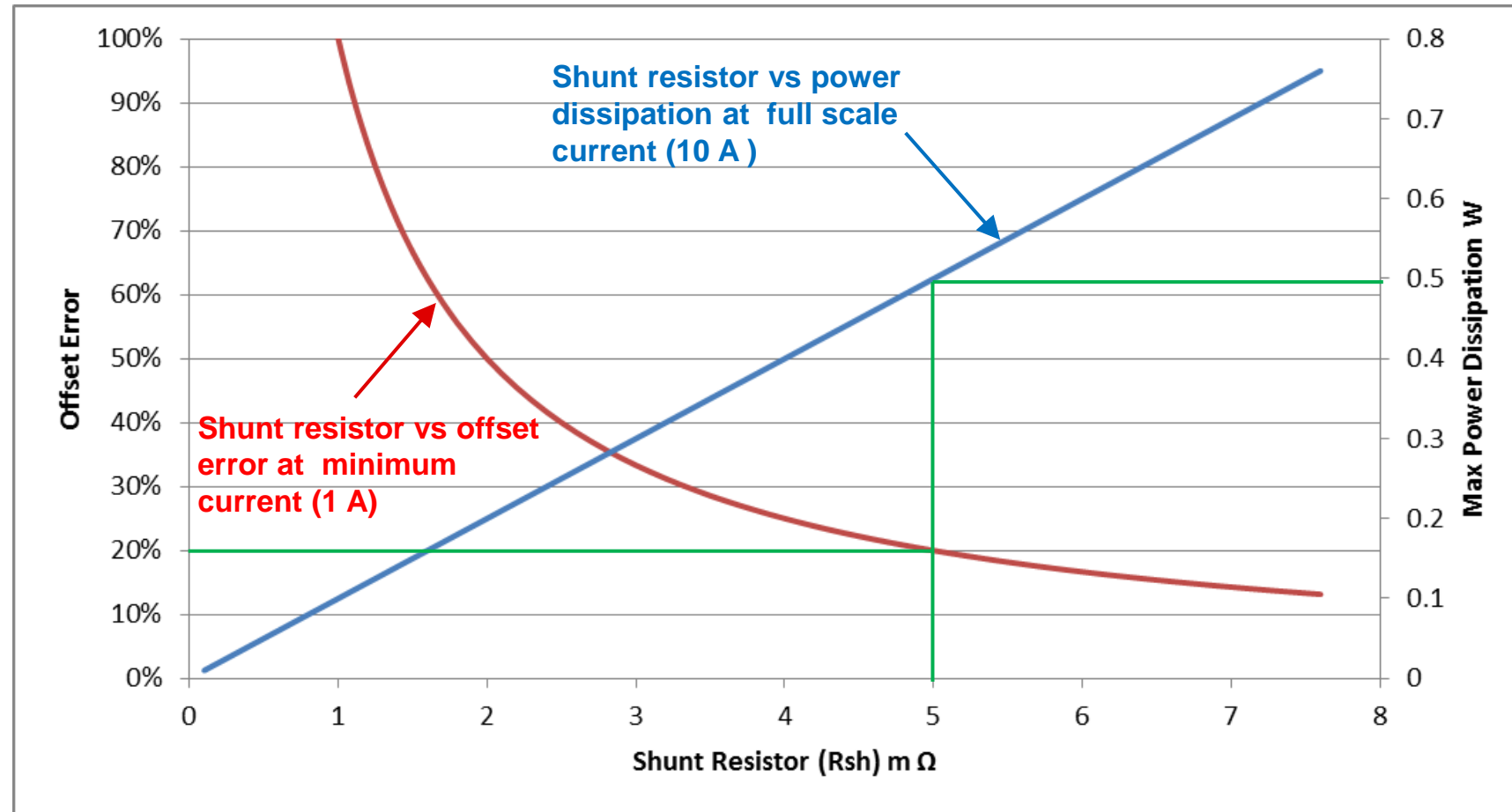

$$\text{Offset error (\%)} = \frac{1 \text{ mV}}{5 \text{ m}\Omega * 1 \text{ A}} * 100 = 20 \%$$

$$\text{Max power dissipation (W)} = 5 \text{ m}\Omega * 10 \text{ A}^2 = 0.5 \text{ W}$$

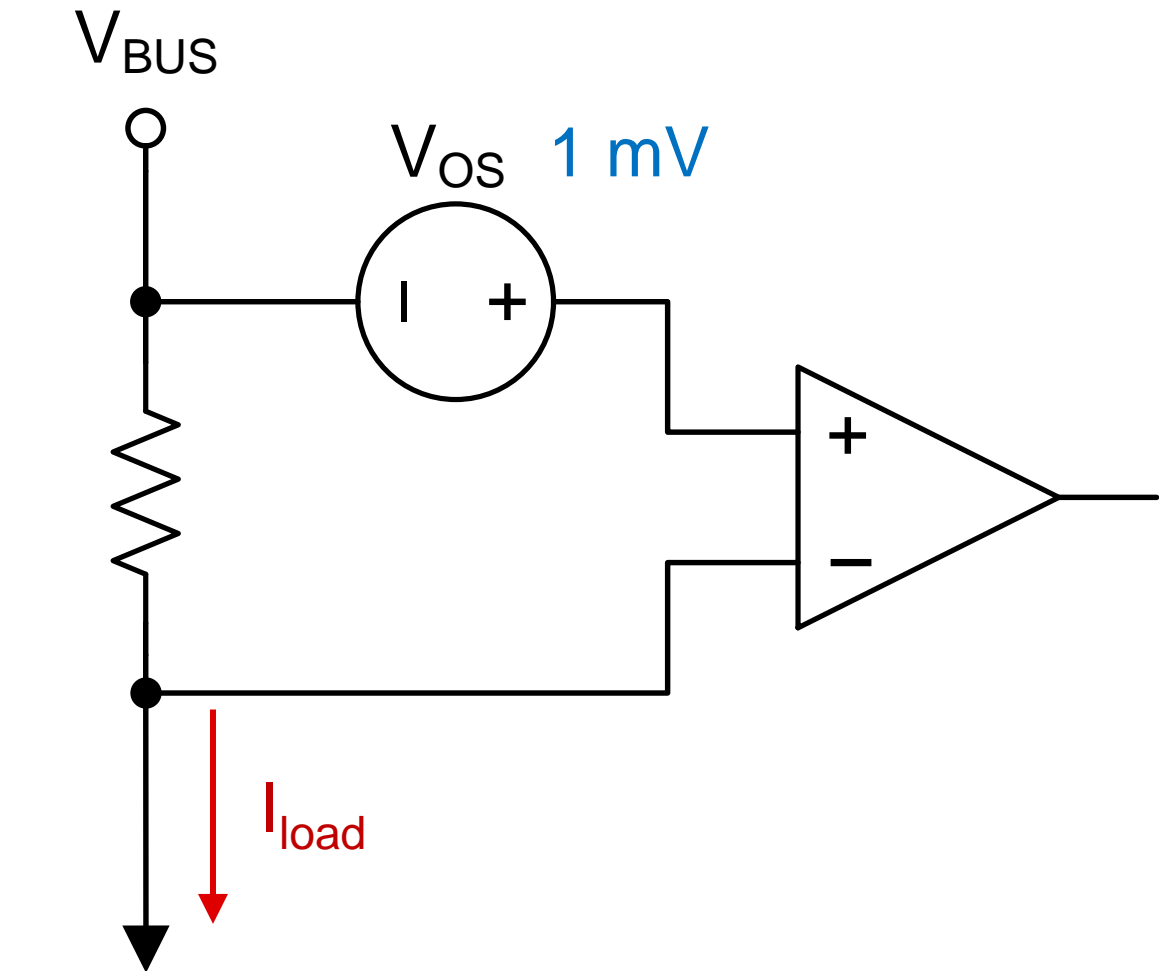

To load

$$I_{load_min} = 1 \text{ A}; I_{load_max} = 10 \text{ A}$$

...and the accuracy at minimum load current of 1A will be 20%.

Power dissipation vs. minimum current accuracy

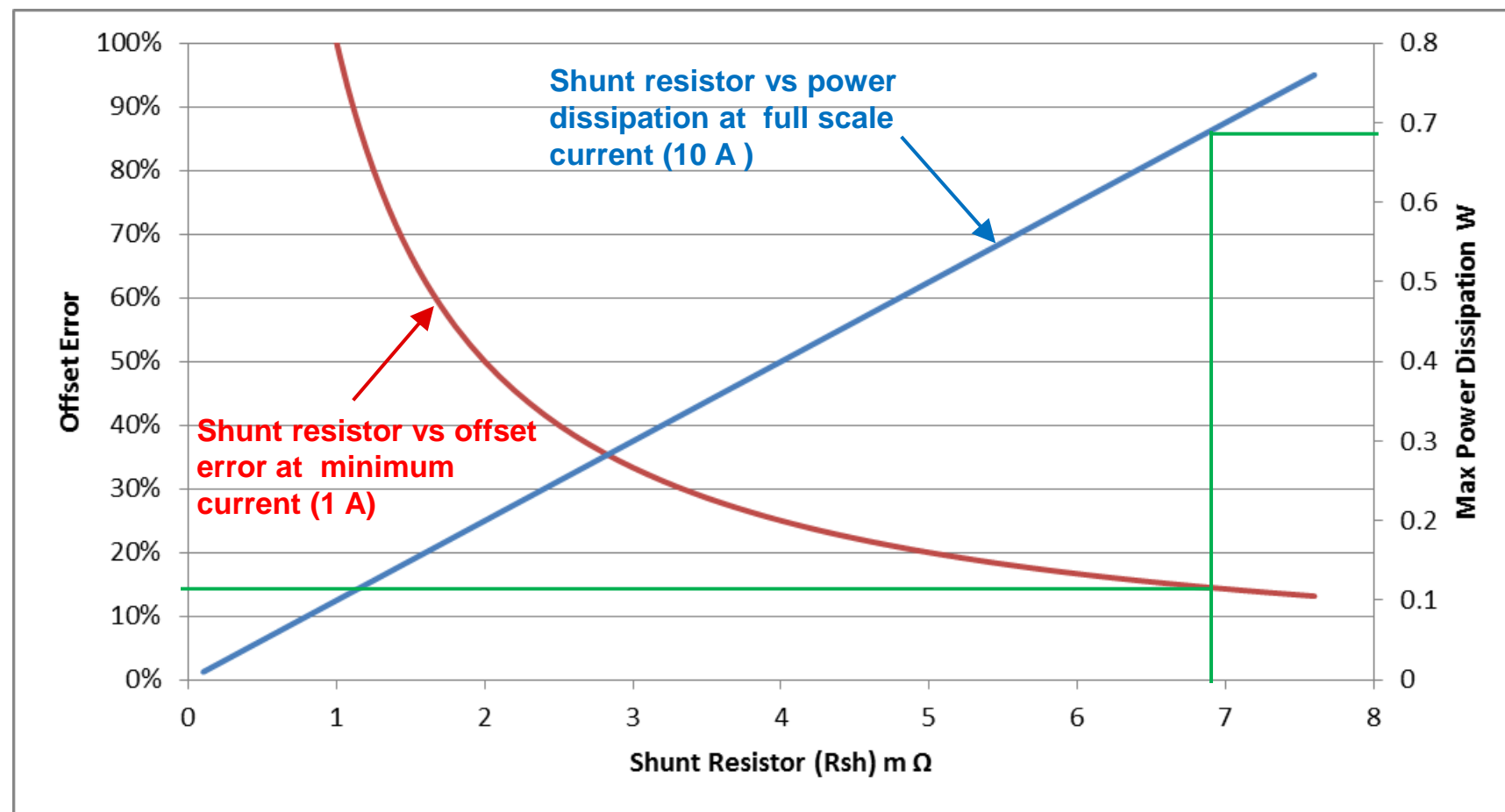

$$\text{Offset error (\%)} = \frac{1 \text{ mV}}{6.66 \text{ m}\Omega * 1 \text{ A}} * 100 = 15 \%$$

$$\text{Max power dissipation (W)} = 6.66 \text{ m}\Omega * 10 \text{ A}^2 = 0.66 \text{ W}$$

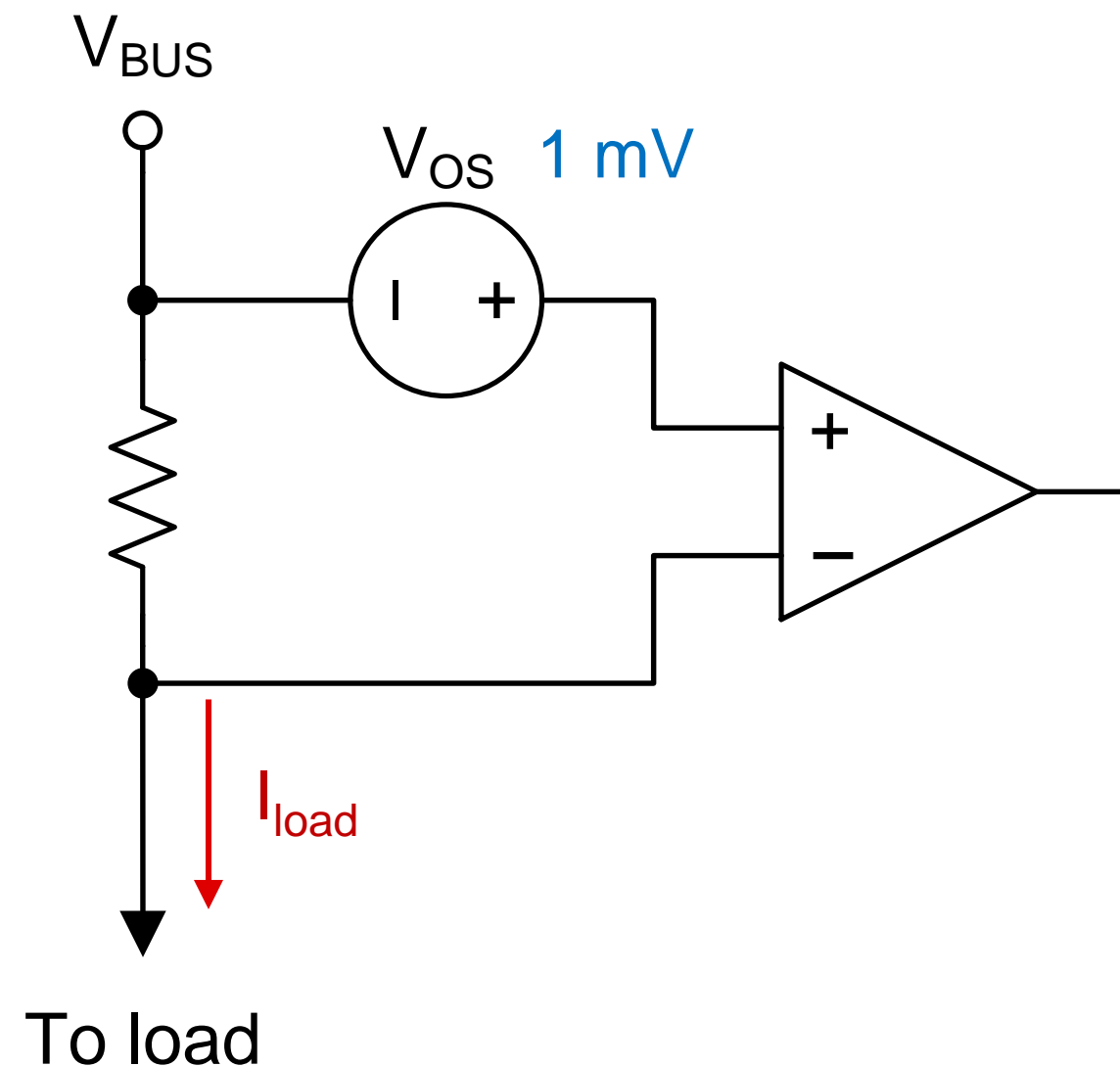

$$I_{load_min} = 1 \text{ A}; I_{load_max} = 10 \text{ A}$$

If we wanted to improve the minimum current accuracy to 15%, then a shunt resistor of about 6.6 milli-ohms can be chosen instead. However, this choice will cost us about 0.66 watts of power dissipation at full scale. A higher power dissipation requirement will drive up the size and the cost of the shunt resistor as I'll show later. So there is a trade off to be made – in this case 5% less error in exchange for 32% more power dissipation and possible increase of the resistor size and cost. It's up to the circuit designer to determine which is more critical in their application.

Maximum value of shunt resistor

Controlled by:

1. Maximum load current
2. Sensing device output full-scale range (Vout)
3. Sensing device gain

$$R_{\text{shunt_max}} = \frac{V_{\text{out}} \div \text{Gain}}{I_{\text{load_max}}}$$

Increasing the shunt resistor gives us better accuracy, but there is an upper bound for the shunt resistor value. Maximum resistor value in an application depends on these factors:

1. Maximum load current to be measured
2. The full-scale output range of the sensing device (or the full-scale input range of the circuitry after the device), and
3. The gain of the sensing device.

The maximum shunt resistor value is calculated as the ratio of the full scale output voltage of the amplifier divided by its gain, all divided by maximum load current. It should be noted that full scale output range depends on the device supply and its output swing limitation.

Shunt resistor tolerance error

- Tolerance = maximum deviation from the ideal value, expressed as a percentage

$$\text{Resistance}_{\text{actual}} = \text{Resistance}_{\text{ideal}} \pm \frac{\text{Tolerance}}{100} * \text{Resistance}_{\text{ideal}}$$

$$\text{Resistance}_{\text{actual}} = 10 \text{ m}\Omega \pm \frac{1}{100} * 10\text{m}\Omega = 10 \text{ m}\Omega \pm 0.1 \text{ m}\Omega$$

$$9.9 \text{ m}\Omega \longrightarrow 10.1 \text{ m}\Omega$$

So far we have discussed the sensing amplifier offset error and how it contributes to the overall accuracy of the system. Shunt resistors are not ideal either, and their non-idealities have a significant impact on system accuracy as well. Among the shunt resistor non-idealities, its tolerance is a significant source of error. It is expressed as a percentage and defined as the maximum deviation from the ideal resistance value.

The actual resistance can vary by the tolerance amount in both the positive or negative direction. For example, a 10 milli-ohm, 1% tolerance shunt resistor can measure 10 milli-ohms plus-or-minus 0.1 milli-ohms. That is, it can vary from 9.9 milli-ohms to 10.1 milli-ohms. Unlike the amplifier offset error, shunt tolerance error contribution is constant over the entire load current range.

Shunt resistor example calculation

PARAMETER	VALUES	PARAMETER	EQUATION	RESULT (INA199A1)
I_{load_min}	100 mA	R_{shunt} (max)	$R_{shunt} = \frac{V_{out} \div Gain}{I_{load_max}} = \frac{5\text{ V} \div 50\text{ V/V}}{10\text{ A}}$	10 mΩ
I_{load_max}	10 A	P_{shunt} (max)	$P_{shunt} = R_{shunt} * I_{load_max}^2 = 10\text{ m}\Omega * 10\text{ A}^2$	1 W
V_{out}	5 V	Error due to offset at minimum load current	$\text{Offset error} = \frac{V_{os}}{R_{shunt} * I_{load_min}} * 100 = \frac{150\ \mu\text{V}}{10\text{ m}\Omega * 100\text{ mA}} * 100$	15 %
Gain (INA199 A1)	50 V/V	Total error at minimum load current		~15%
Gain error (INA199 A1)	1.5 %	Error due to offset at maximum load current	$\text{Offset error} = \frac{V_{os}}{R_{shunt} * I_{load_min}} * 100 = \frac{150\ \mu\text{V}}{10\text{ m}\Omega * 10\text{ A}} * 100$	0.15 %
V_{os_max} (INA199A1)	150 μV	Total error at maximum load current	$R_{shunt} \text{ tolerance} = 1\%$	~ 1.8 %

Now let's work through a real-world example to better understand what we have discussed so far. In this example, the minimum current is 100mA and the maximum current is 10 A. We chose the INA199A1 as the current sense amplifier for this application, which has a maximum VOS spec of 150 uV. In this example we will ignore other sources of amplifier error for simplicity. The gain of this device is 50 V/V, and the required full-scale output voltage is 5V.

Using the equations we introduced earlier, the maximum Rshunt is calculated to be 10 milli-ohms. The 10 milli-ohm shunt resistor will dissipate 1 W of power at 10 A, and error due to offset at 100 mA of current is 15 %. Offset voltage contribution to error at maximum current is 0.15%. But at the full scale input, there are other error sources like amplifier gain error and shunt resistor tolerance error that dominate. Therefore, choosing a resistor with 1% tolerance, and given the 1.5 % maximum gain error of INA199A1, the total error at full scale is around 1.8%. Total error is calculated by adding error sources as the root sum of squares, which is discussed in detail in other videos in this series. If the chosen shunt resistor has a tolerance greater than 1.5% then the tolerance will dominate full scale error in this case.

Shunt resistor typical pricing

PACKAGE	TOLERANCE (%)	RESISTANCE (mΩ)	POWER RATING (W)	UNIT PRICE (\$)
805	1	10	0.5	0.53
1206	1	10	1	0.64
2512	1	10	2	0.65
1206	0.5	10	0.5	0.74
2512	0.5	10	1	1.66
2512 wide	0.5	10	2	2.16

Here is a table listing unit price for 10 milli-ohm resistors with different tolerance and power ratings. It can be noted that in general, price goes up with higher power and larger sized resistors. And choosing a higher precision resistor with low tolerance also demands higher price and larger board space.

Shunt resistor summary

- R_{SHUNT} definition
- Primary factors for choosing R_{SHUNT}
 1. Accuracy at minimum current
 2. Power dissipation at maximum current
- How to calculate R_{SHUNT_MAX}

$$R_{shunt_max} = \frac{V_{out} \div \text{Gain}}{I_{load_max}}$$



In summary, in this video we defined the shunt resistor and discussed the tradeoffs between minimum current accuracy and power dissipation at maximum current. We then discussed how to calculate the maximum value of the shunt resistor for an application. Finally, we briefly touched upon the shunt resistor tolerance error and its effect on system accuracy.

To find more current sense amplifier technical resources and search products, visit ti.com/currentsense

That concludes this video - thank you for watching! Please try the quiz to check your understanding of the content.

For more information and videos on current sense amplifiers please visit [ti.com/currentsense](https://www.ti.com/currentsense).

How to Choose a Shunt Resistor

TI Precision Labs – Current Sense Amplifiers

Quiz

How to choose a shunt resistor – quiz

1. Which is **not** a primary factor driving R_{shunt} value selection?
 - a) Maximum current accuracy
 - b) Minimum current accuracy
 - c) Resistor size and cost
 - d) Maximum power dissipation

2. Error due to amplifier offset voltage (V_{OS}) _____ as R_{shunt} increases.
 - a) Increases
 - b) Decreases
 - c) Stays the same
 - d) None of the above

How to choose a shunt resistor – quiz

3. Power dissipation at max load current _____ as R_{shunt} decreases.
- a) Increases
 - b) Decreases
 - c) Stays the same
 - d) None of the above
4. A 5 m Ω resistor with 5% tolerance can have a value from _____.
- a) 4.95 m Ω to 5.05 m Ω
 - b) 4.50 m Ω to 5.50 m Ω
 - c) 4.90 m Ω to 5.10 m Ω
 - d) 4.75 m Ω to 5.25 m Ω

How to choose a shunt resistor – quiz

5. What is the offset error (%) when $V_{os} = 1 \text{ mV}$ and $V_{sense} = 5 \text{ mV}$?
- a) 2.5%
 - b) 5%
 - c) 10%
 - d) 20%
6. As resistor power handling and size increases, price typically _____.
- a) Increases
 - b) Decreases
 - c) Stays the same
 - d) None of the above

Answers

How to choose a shunt resistor – quiz

1. Which is **not** a primary factor driving R_{shunt} value selection?
 - a) Maximum current accuracy
 - b) Minimum current accuracy
 - c) Resistor size and cost
 - d) Maximum power dissipation

2. Error due to amplifier offset voltage (V_{OS}) _____ as R_{shunt} increases.
 - a) Increases
 - b) Decreases
 - c) Stays the same
 - d) None of the above

How to choose a shunt resistor – quiz

3. Power dissipation at max load current _____ as R_{shunt} decreases.
- a) Increases
 - b) Decreases
 - c) Stays the same
 - d) None of the above
4. A $5\text{ m}\Omega$ resistor with 5% tolerance can have a value from _____.
- a) $4.95\text{ m}\Omega$ to $5.05\text{ m}\Omega$
 - b) $4.50\text{ m}\Omega$ to $5.50\text{ m}\Omega$
 - c) $4.90\text{ m}\Omega$ to $5.10\text{ m}\Omega$
 - d) $4.75\text{ m}\Omega$ to $5.25\text{ m}\Omega$

How to choose a shunt resistor – quiz

5. What is the offset error (%) when $V_{os} = 1 \text{ mV}$ and $V_{sense} = 5 \text{ mV}$?

- a) 2.5%
- b) 5%
- c) 10%
- d) 20%

6. As resistor power handling and size increases, price typically _____.

- a) Increases
- b) Decreases
- c) Stays the same
- d) None of the above