

Introduction to reference noise in ADC systems

TI Precision Labs – ADCs

Created by Chris Hall & Bryan Lizon

Presented by Alex Smith

Total system noise

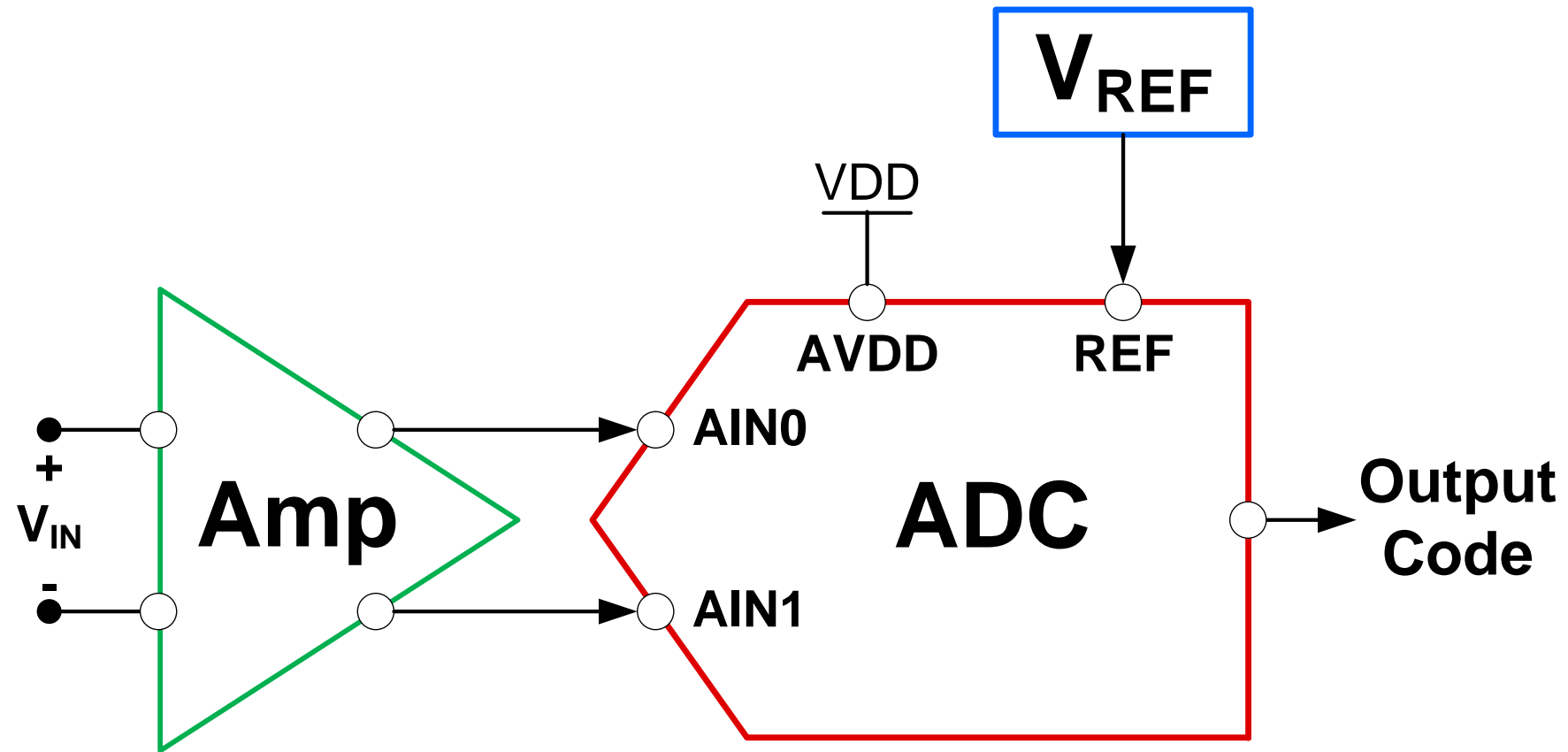

$$\text{Total noise} = \sqrt{V_{N,ADC(RTI)}^2 + V_{N,AMP(RTI)}^2 + V_{N,REF(RTI)}^2}$$

How VREF noise enters the signal chain

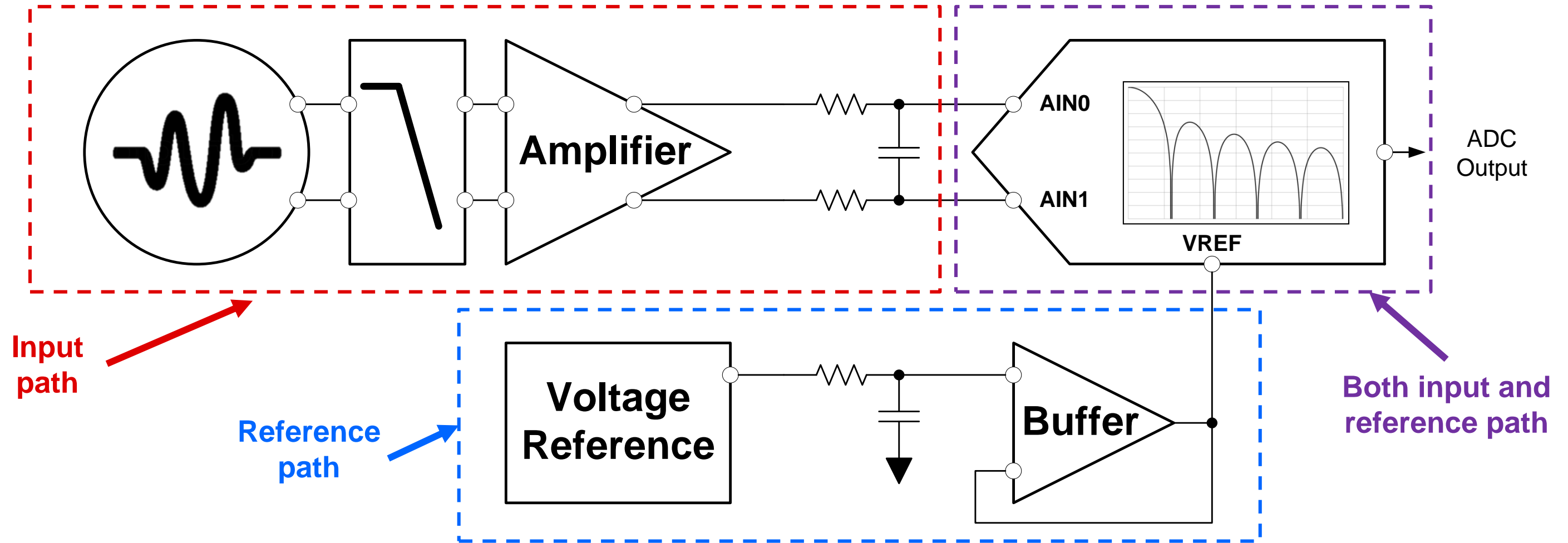

$$\text{Output Code} = V_{IN (RMS)} * \left(\frac{2^N}{V_{REF} + V_{N,REF (RMS)}} \right)$$

Does datasheet ADC noise include VREF noise?

Input-sinewave test (SNR, SINAD, etc.)

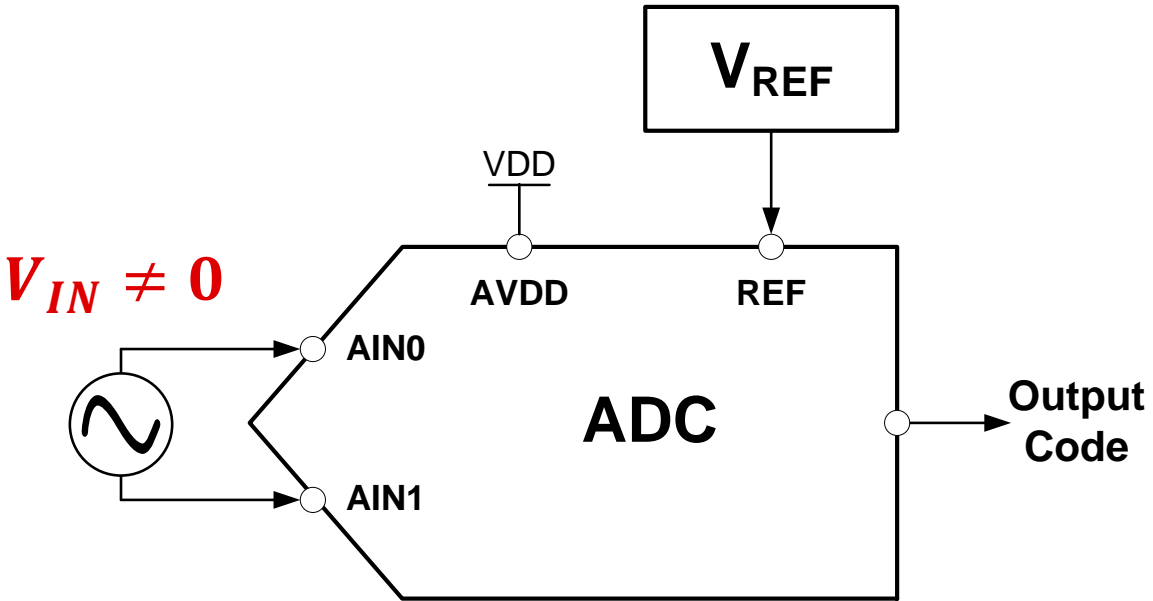

$$Output\ Code = V_{IN(RMS)} * \left(\frac{2^N}{V_{REF} + V_{N,REF(RMS)}} \right) \neq 0$$

Includes reference & ADC noise

Input-short noise test (effective resolution, NFB)

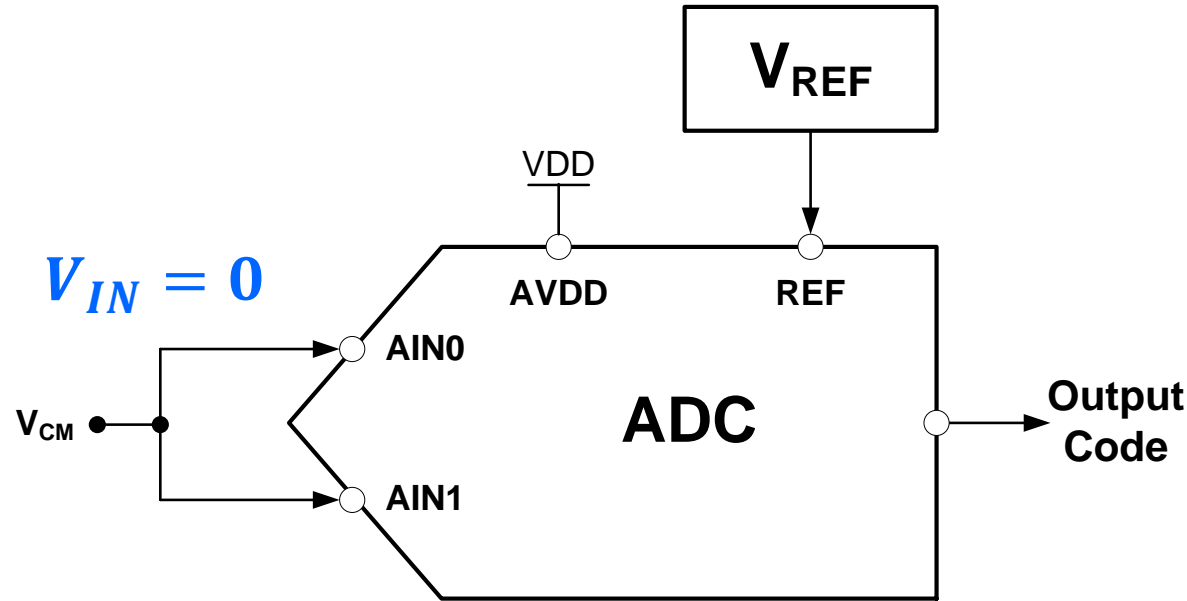

$$Output\ Code = V_{IN(RMS)} * \left(\frac{2^N}{V_{REF} + V_{N,REF(RMS)}} \right) \cong 0$$

ADC noise only

Deriving how VREF noise impacts the system

	Comment	Equation
Step 1	Output code equation ↓	$V_{IN (RMS)} * \left(\frac{2^N}{V_{REF} + V_{N,REF (RMS)}} \right)$
Step 2	Multiply by $\frac{V_{REF}}{V_{REF}}$ ↓	$\frac{V_{IN (RMS)}}{V_{REF}} * \left(\frac{2^N}{1 + \frac{V_{N,REF (RMS)}}{V_{REF}}} \right)$
Step 3	Simplify using binomial approximation** ↓	$\frac{V_{IN (RMS)} * 2^N}{V_{REF}} * \left(1 - \frac{V_{N,REF (RMS)}}{V_{REF}} \right)$
Step 4	Distribute	<div style="display: flex; justify-content: space-around;"> <div style="border: 1px dashed red; padding: 5px;"> $\frac{V_{IN (RMS)} * 2^N}{V_{REF}}$ </div> <div style="border: 1px dashed blue; padding: 5px;"> $\frac{V_{IN (RMS)} * 2^N * V_{N,REF (RMS)}}{V_{REF}^2}$ </div> </div>
		<div style="display: flex; justify-content: space-around;"> <div style="border: 1px dashed red; padding: 5px; color: red;">Signal (in codes)</div> <div style="border: 1px dashed blue; padding: 5px; color: blue;">V_{REF} (noise) (in codes)</div> </div>

Step 5: V_{REF} (noise) in Volts (RTI)

$$= \frac{V_{IN (RMS)} * 2^N * V_{N,REF (RMS)}}{V_{REF}^2} * \frac{V_{REF}}{2^N}$$

$$= \frac{V_{IN (RMS)}}{V_{REF}} * V_{N,REF (RMS)}$$

**https://en.wikipedia.org/wiki/Binomial_approximation

Plotting VREF noise for DC signals

System Parameters

- $V_{REF} = 2.5 \text{ V}$
- $V_{N,REF (RMS)} = 10 \mu\text{V}_{RMS}$
- $V_{IN (RMS)} = \text{DC input swept from } 0 \text{ V to } +\text{FS}$

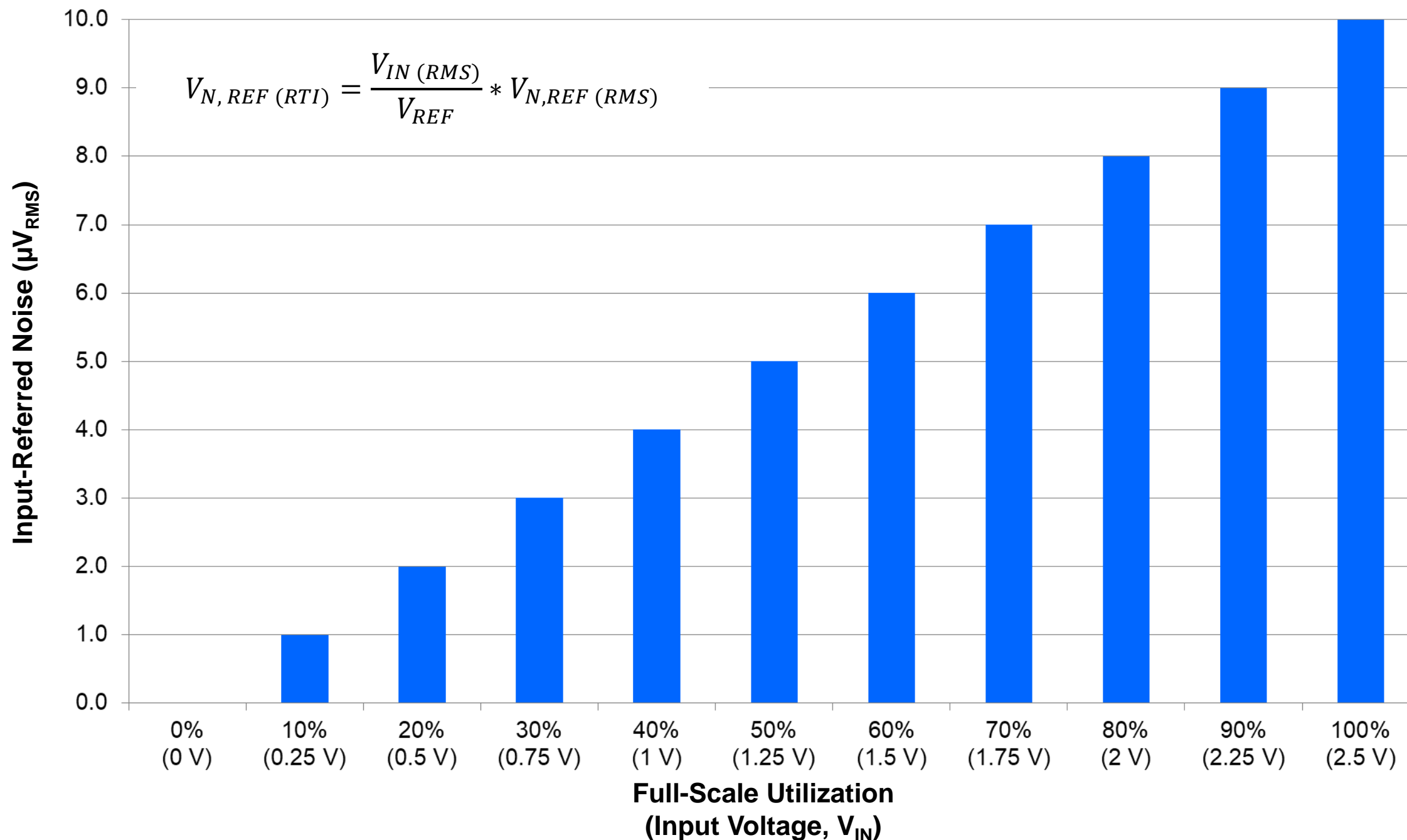

Simulating VREF noise for AC signals

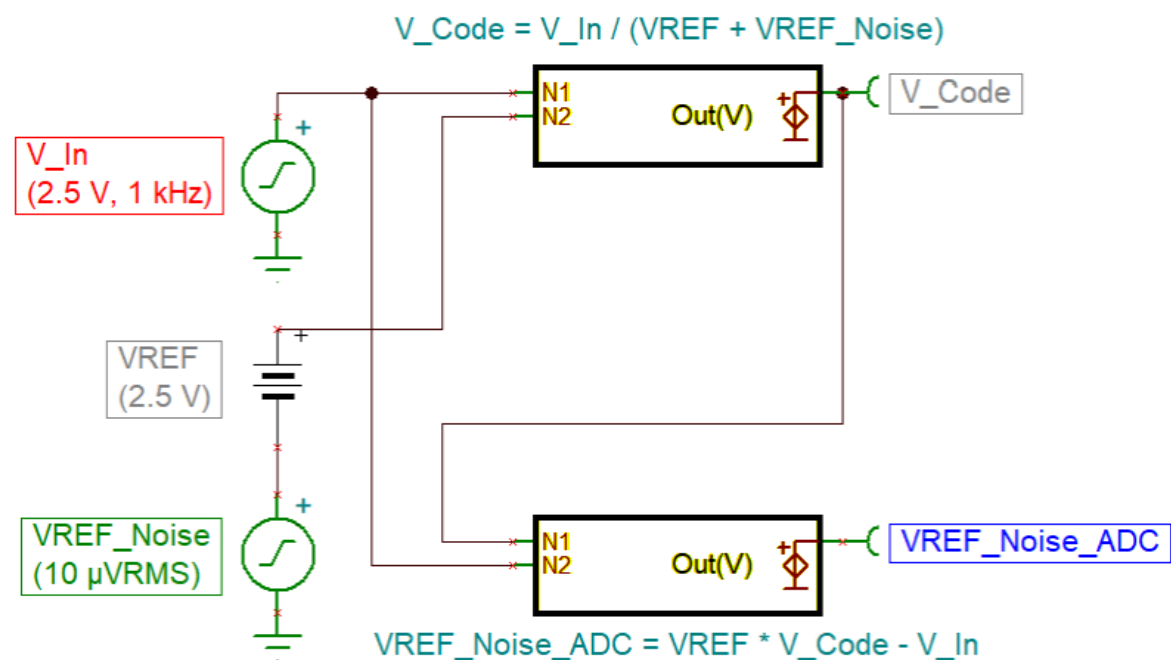

$$\begin{aligned}
 V_{N,REF(RTI)} &= \frac{V_{IN(RMS)}}{V_{REF}} * V_{N,REF(RMS)} \\
 &= \frac{2.5 V}{2.5 V * \sqrt{2}} * 10 \mu V_{RMS} \\
 &= 7.08 \mu V_{RMS}
 \end{aligned}$$

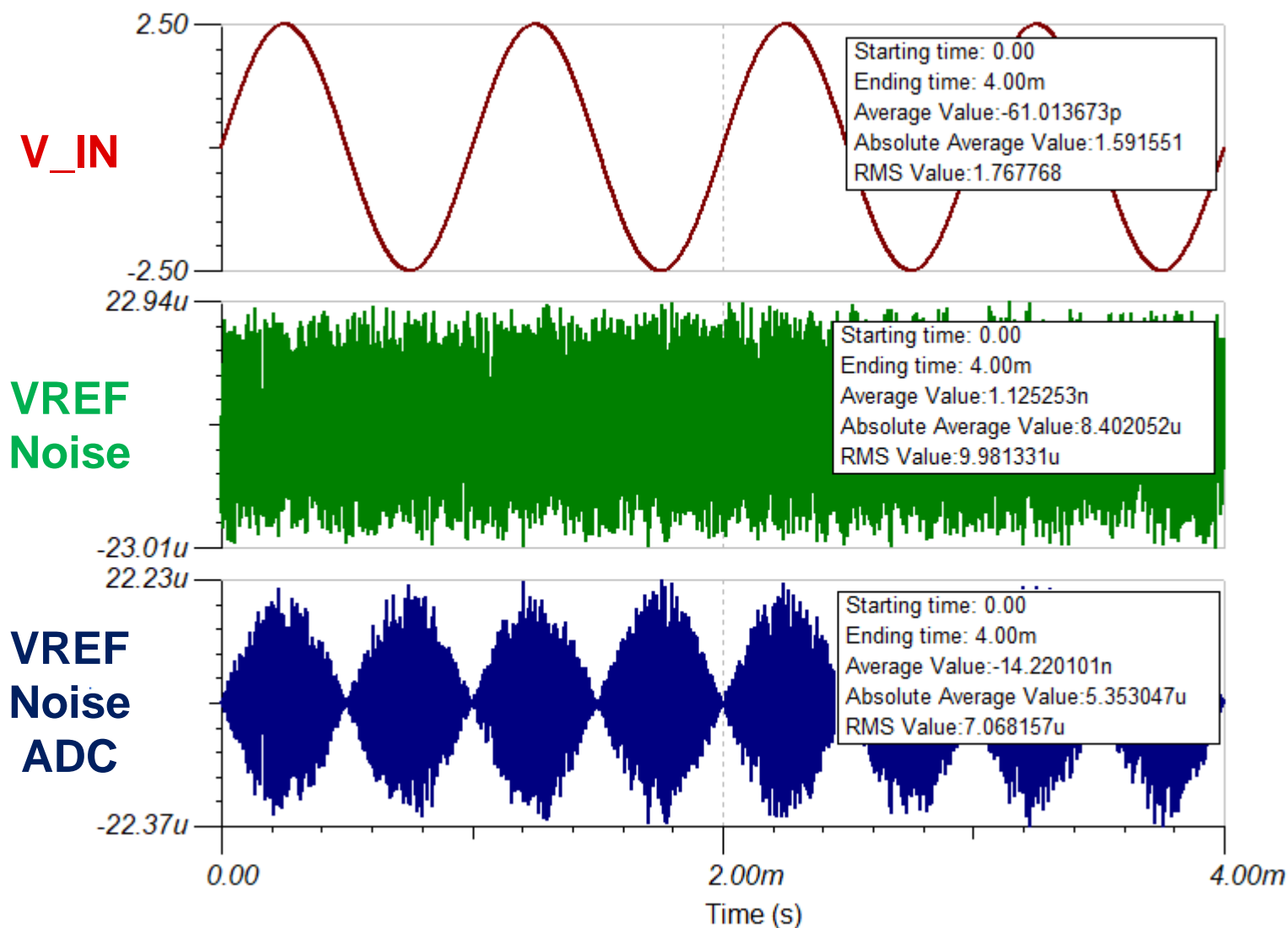

Calculating reference noise (REF60xx)

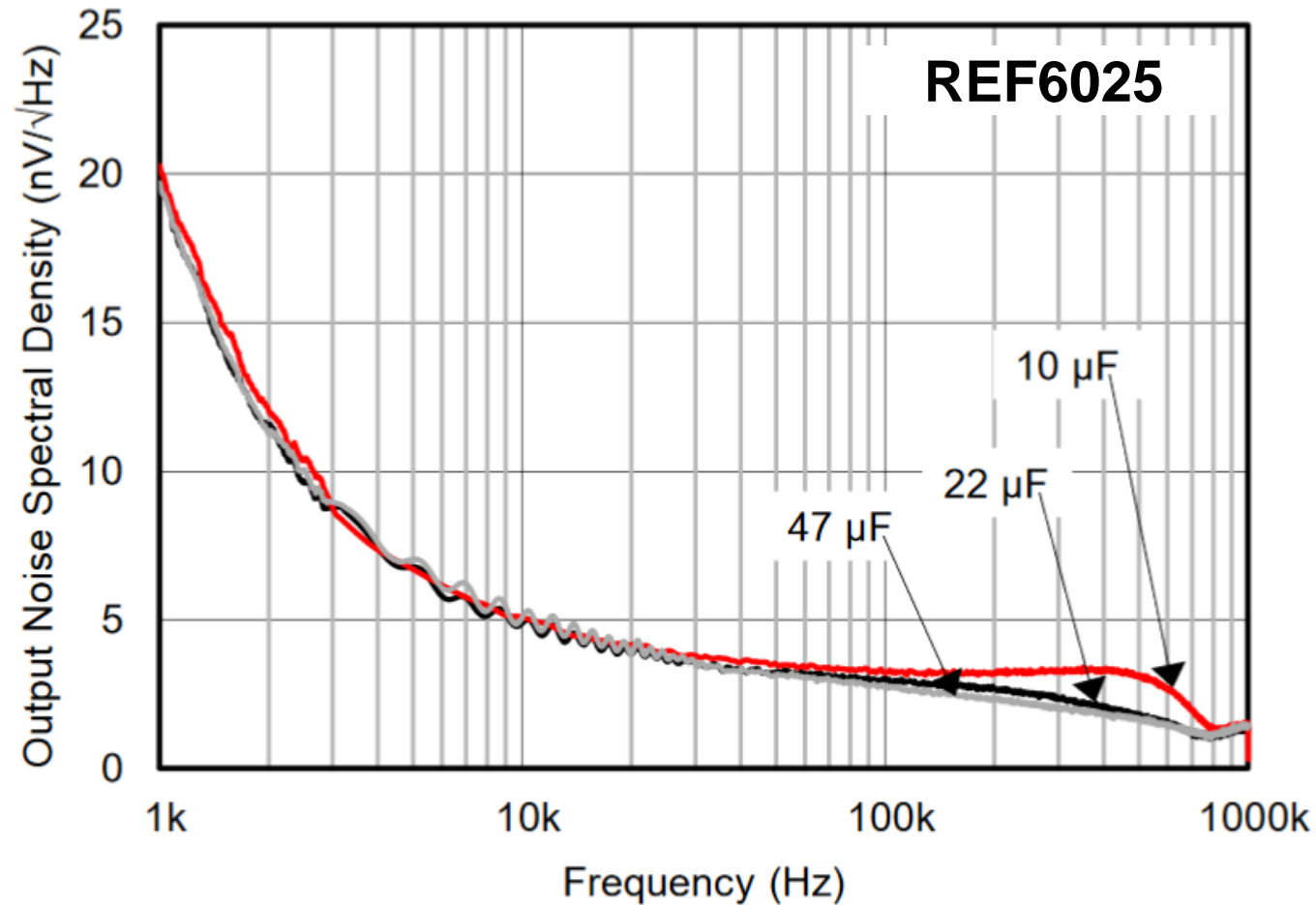

PARAMETER	TEST CONDITIONS	MIN	TYP	MAX	UNIT
NOISE					
Total integrated noise	$C_L = 22 \mu\text{F}$		5		μV_{RMS}
	$C_L = 47 \mu\text{F}$		5		
Low frequency noise	$0.1 \text{ Hz} \leq f \leq 10 \text{ Hz}$		3		$\mu\text{V}_{\text{PP}}/\text{V}$

$$\text{REF6025}_{1/f \text{ noise}} = 3 \frac{\mu\text{V}_{\text{PP}}}{\text{V}} * 2.5 \text{ V} = 7.5 \mu\text{V}_{\text{PP}} (\sim 1.14 \mu\text{V}_{\text{RMS}})$$

For REF6025 noise at other frequencies e.g. 100 Hz, use equations** or simulation

**View the Precision Labs modules on amplifier noise & effective noise bandwidth to learn how to calculate total noise

Simulating reference noise (REF60xx)

Simulated circuit

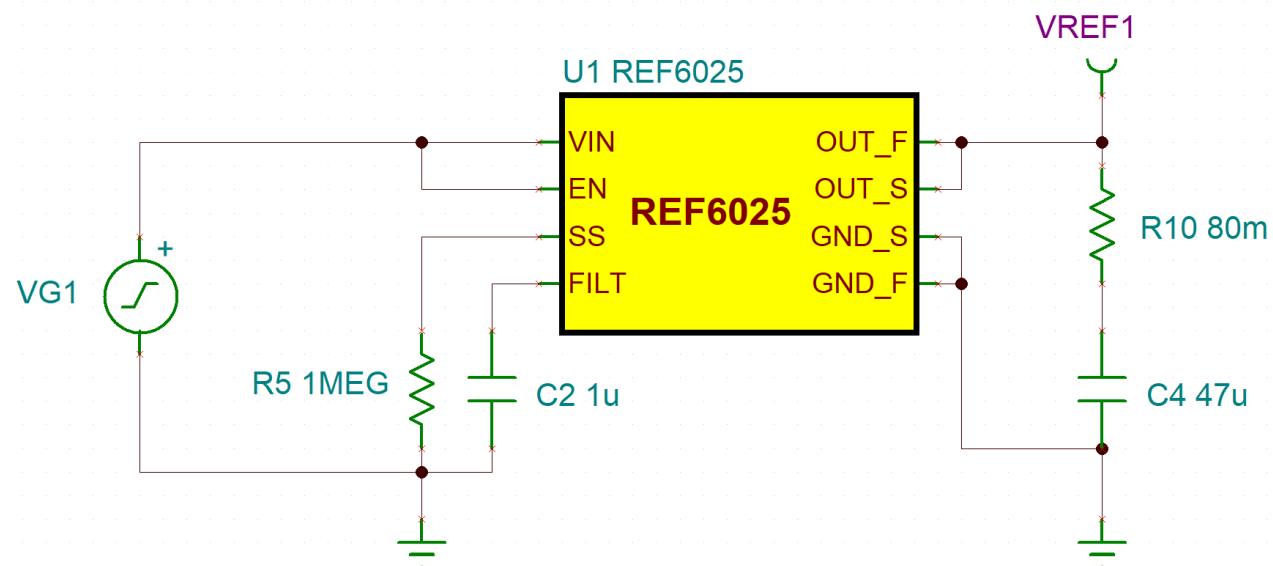

Total output noise @ 10 Hz & 100 Hz

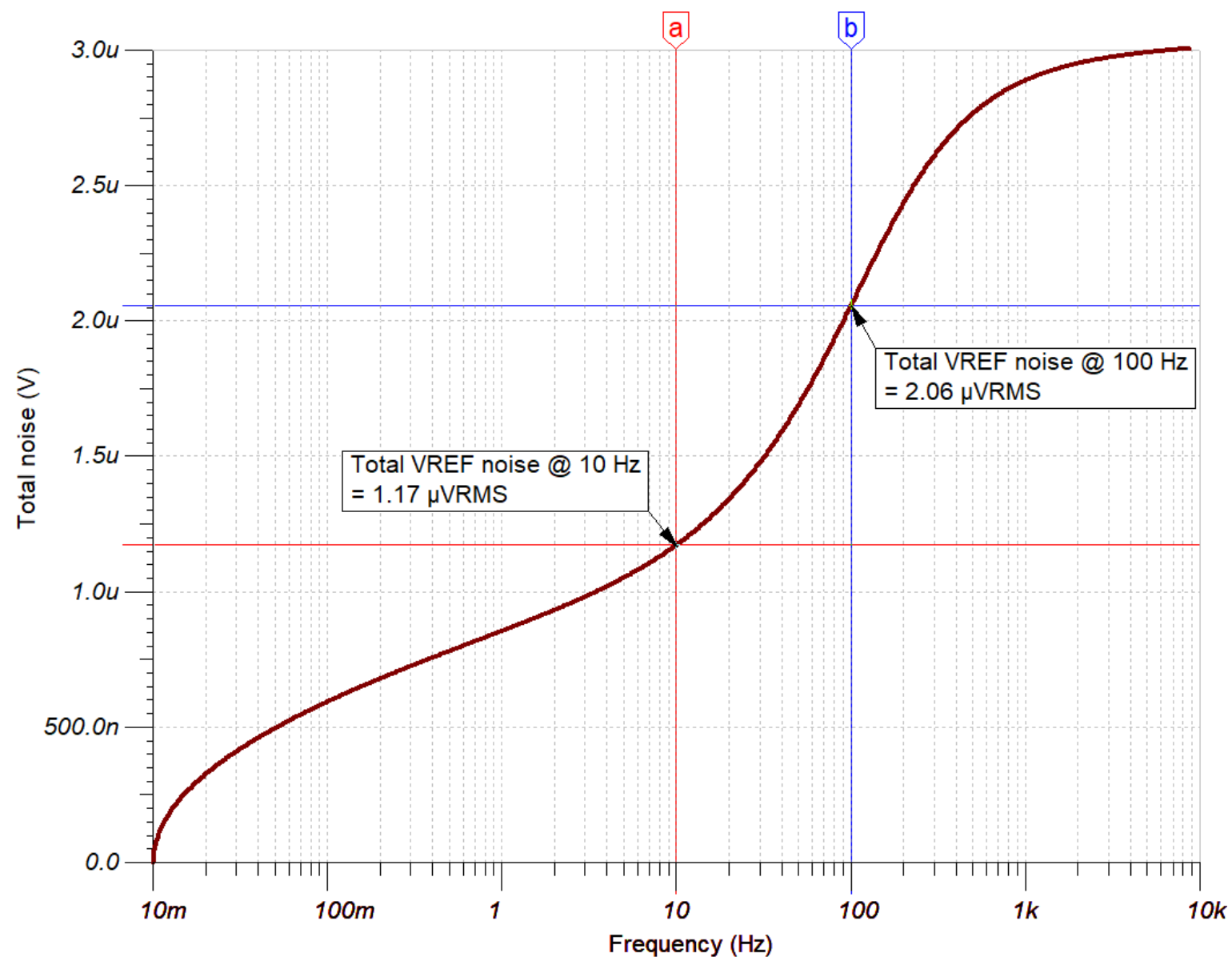

Effects of low-frequency (1/f) reference noise

FFT of $V_{IN} = 2.5 V_p, 1 \text{ kHz}$
(BB noise only)

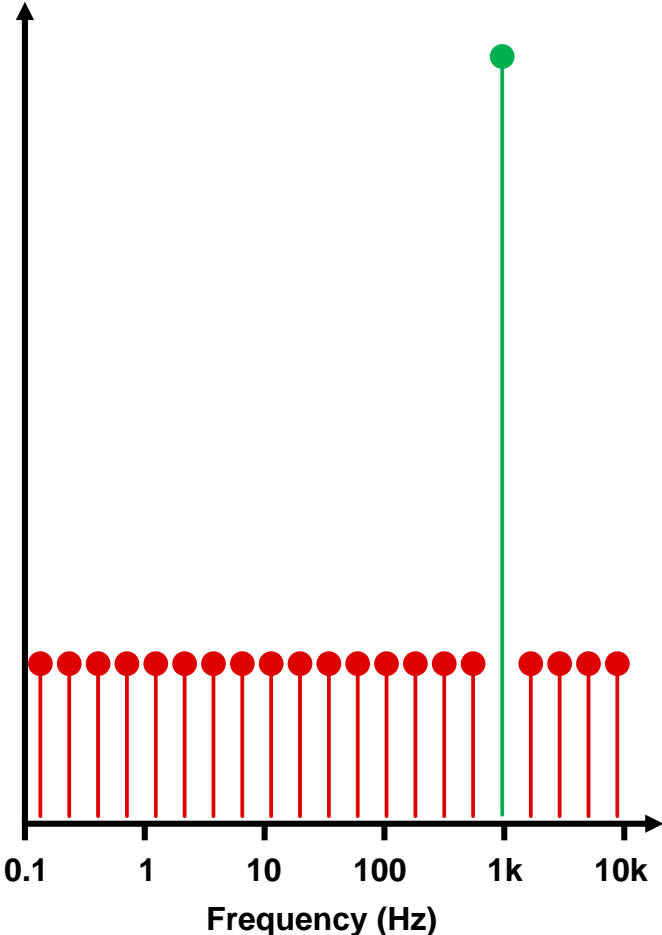

+

VREF noise vs frequency
(BB & 1/f noise)

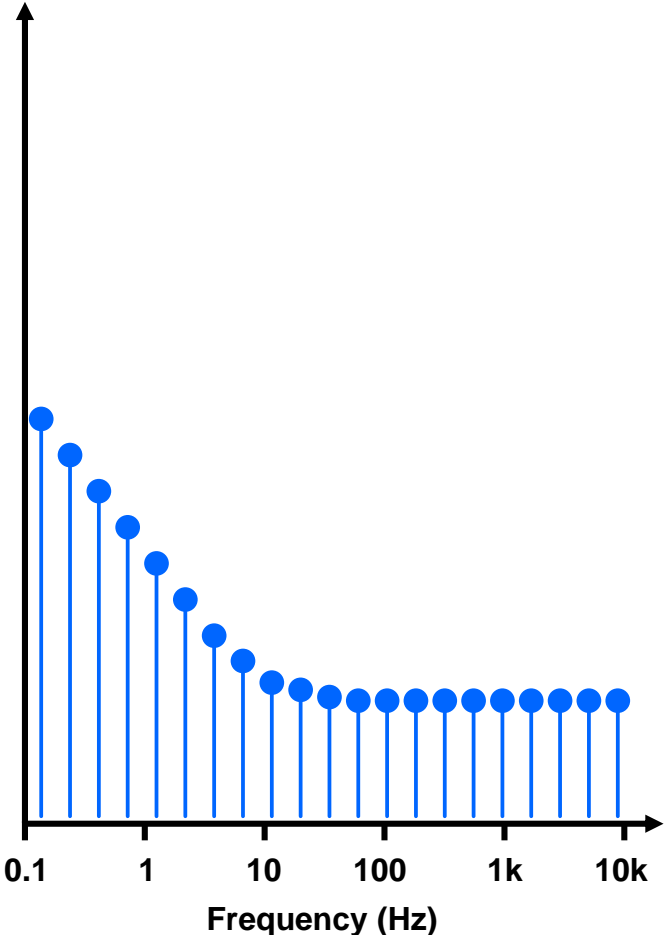

=

FFT of $V_{IN} = 2.5 V_p, 1 \text{ kHz}$
(BB & 1/f noise)

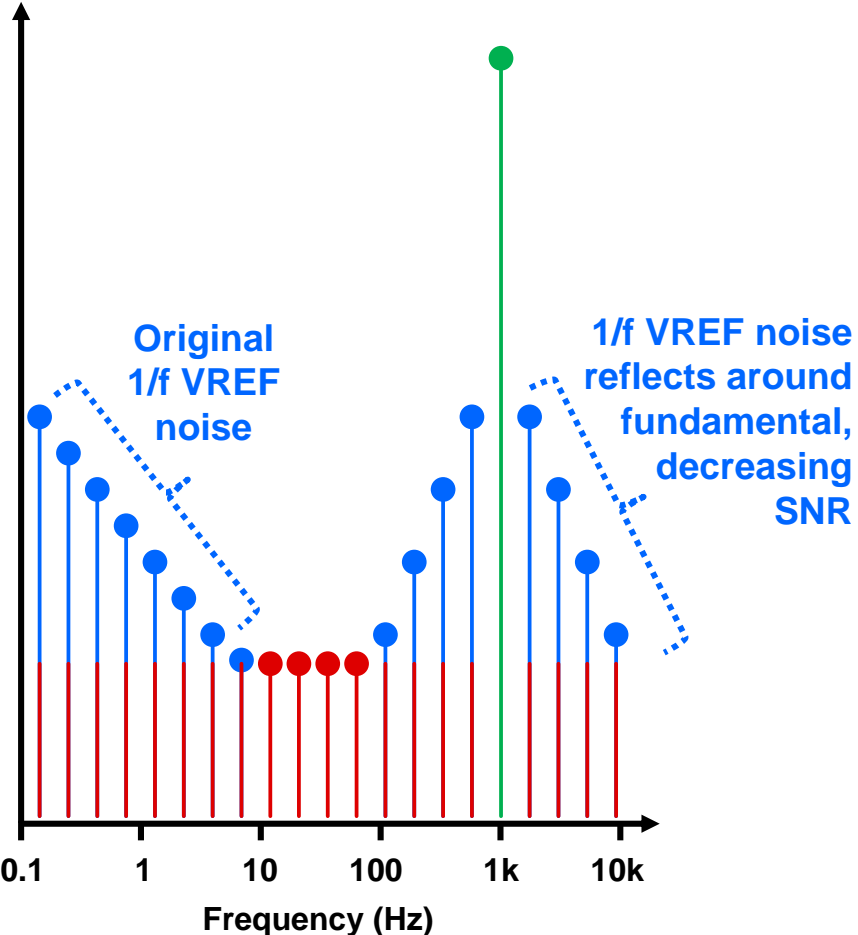

Low-frequency VREF noise often dominates the overall system noise performance

Thanks for your time!
Please try the quiz.

Quiz: Intro to reference noise in ADC systems

1. How will applying a DC input signal impact the system noise due to the voltage reference?
 - a. The input signal has no impact on the reference noise
 - b. The reference noise at the output will be directly proportional to the DC input signal
 - c. Reference noise is only impacted by AC input signals
 - d. The reference noise at the output will be inversely proportional to the DC input signal

Quiz: Intro to reference noise in ADC systems

1. How will applying a DC input signal impact the system noise due to the voltage reference?
 - a. The input signal has no impact on the reference noise
 - b. The reference noise at the output will be directly proportional to the DC input signal
 - c. Reference noise is only impacted by AC input signals
 - d. The reference noise at the output will be inversely proportional to the DC input signal

Quiz: Intro to reference noise in ADC systems

2. (T/F) When applying a sinusoidal input, the output reference noise will be proportional to the RMS of the sine wave?
 - a. True
 - b. False

Quiz: Intro to reference noise in ADC systems

2. (T/F) When applying a sinusoidal input, the output reference noise will be proportional to the RMS of the sine wave?

a. True

b. False

Quiz: Intro to reference noise in ADC systems

3. How does the $1/f$ noise in the voltage reference show up in the ADC output spectrum?
 - a. It shows up in the same frequency range in the output spectrum as it does in the reference noise
 - b. It shows up as skirts on any AC signal applied to the system
 - c. Both A & B

Quiz: Intro to reference noise in ADC systems

3. How does the $1/f$ noise in the voltage reference show up in the ADC output spectrum?
- a. It shows up in the same frequency range in the output spectrum as it does in the reference noise
 - b. It shows up as skirts on any AC signal applied to the system
 - c. Both A & B

Thanks for your time!



© Copyright 2020 Texas Instruments Incorporated. All rights reserved.

This material is provided strictly “as-is,” for informational purposes only, and without any warranty.
Use of this material is subject to TI’s **Terms of Use**, viewable at [TI.com](https://www.ti.com)

Introduction to reference noise in ADC systems

TI Precision Labs – ADCs

Created by Chris Hall & Bryan Lizon

Presented by Alex Smith



Hello, and welcome to the TI Precision Lab introducing reference noise in ADC systems. This module begins with a discussion about how reference noise enters your signal chain and how it's characterized by an ADC, continues by delving into the reference's impact on system noise and closes with a calculation and simulation of voltage reference output noise using a component's datasheet. Follow up presentations discuss how a voltage reference noise affects ADC performance as well as ways to minimize reference noise

To begin, let's first consider the ultimate goal that we are trying to accomplish

Total system noise

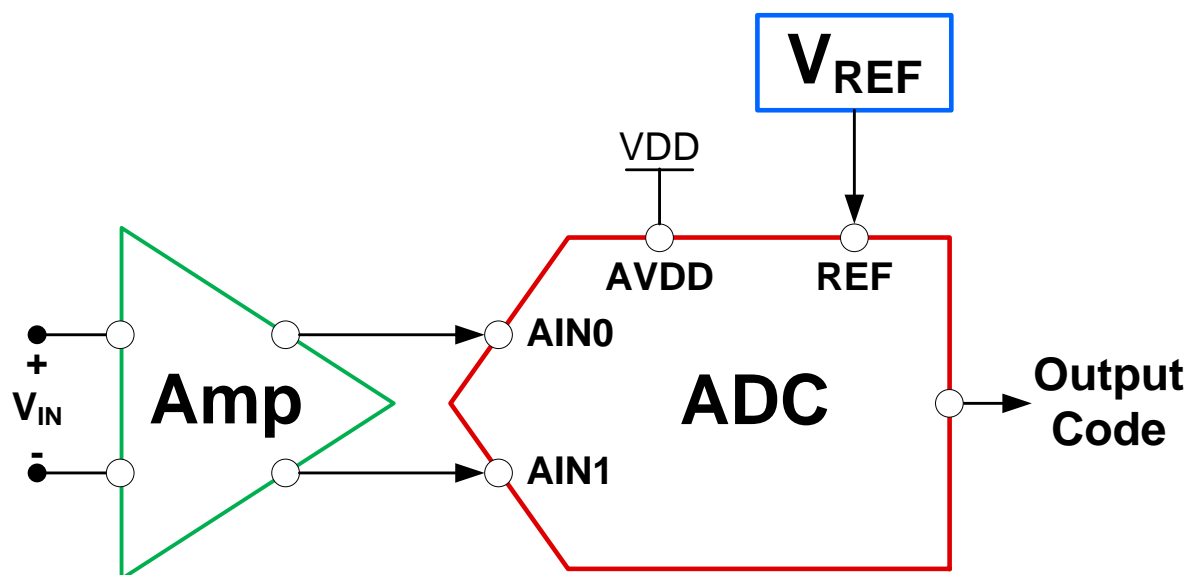

$$\text{Total noise} = \sqrt{V_{N,ADC(RTI)}^2 + V_{N,AMP(RTI)}^2 + V_{N,REF(RTI)}^2}$$

Shown here is a simplified signal chain block diagram consisting of an amplifier, an ADC, and a voltage reference. Throughout the Precision Labs ADC modules on noise, the goal has been to understand how noise enters this system and how noise affects each component. With this knowledge, you can then determine the total noise for a system like the one shown here and represented by the equation at the bottom of the slide.

Two of the three terms in this total noise equation have been discussed in detail in the previous Precision Labs modules: ADC noise and amplifier noise. In both cases, you can use these presentations to determine the input-referred noise for each component. This module focuses on the third term, using the superposition principle to focus on, and determine an equation for, the input-referred voltage reference noise. Doing so helps illustrate how reference noise interacts with the other noise sources shown here, as well as how reference noise affects the overall system performance.

Given that the goal is clear, [let's delve deeper into this topic by identifying how reference noise enters the signal chain.](#)

How VREF noise enters the signal chain

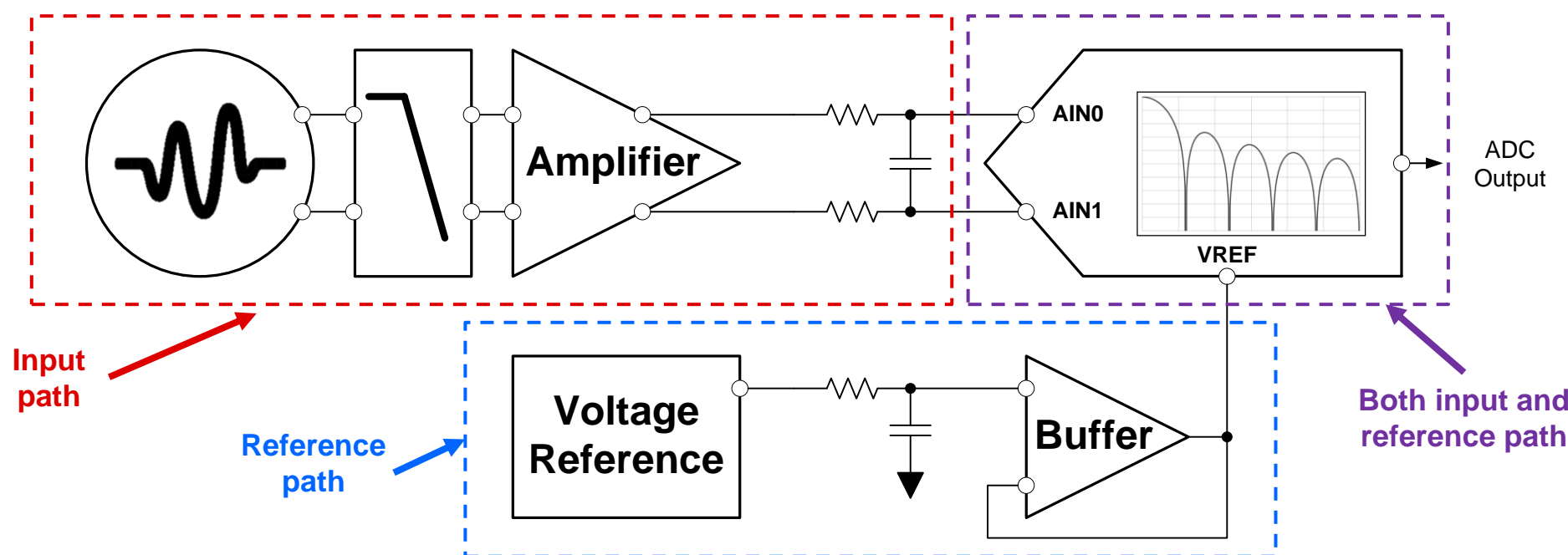

$$\text{Output Code} = V_{IN (RMS)} * \left(\frac{2^N}{V_{REF} + V_{N,REF (RMS)}} \right)$$

To understand how reference noise enters your system, let's expand the signal chain shown on the previous slide to include additional components. This signal chain is taken from the Precision Labs modules on effective noise bandwidth, and consists of two distinct paths. First is the input path, highlighted in red, which includes an amplifier and an ADC. The second path is the reference path in blue, which can include a filter and a buffer. The delta-sigma ADC's digital filter serves as an intersection point between these two paths, and is highlighted in purple. The digital filter acts on a delta-sigma ADC's modulated bitstream, which is equal to the maximum code value scaled by the ratio of the RMS input signal and the reference voltage, per the output code equation shown here. Therefore, the digital filter can band-limit both the input noise and the reference noise in a delta-sigma ADC. This would not be the case for a SAR ADC, though the output code equation is valid for either ADC architecture.

One other important characteristic of the output code equation is that the RMS reference noise directly affects the ADC's output. Given this relationship, it is fair to assume that the noise reported in an ADC's datasheet must include some reference noise. The next slide discusses when this is true

Does datasheet ADC noise include VREF noise?

Input-sinewave test (SNR, SINAD, etc.)

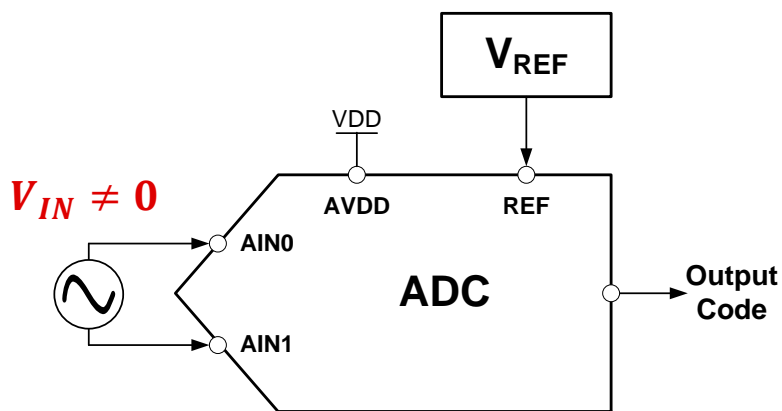

$$\text{Output Code} = V_{IN(RMS)} * \left(\frac{2^N}{V_{REF} + V_{N,REF(RMS)}} \right) \neq 0$$

Includes reference & ADC noise

Input-short noise test (effective resolution, NFB)

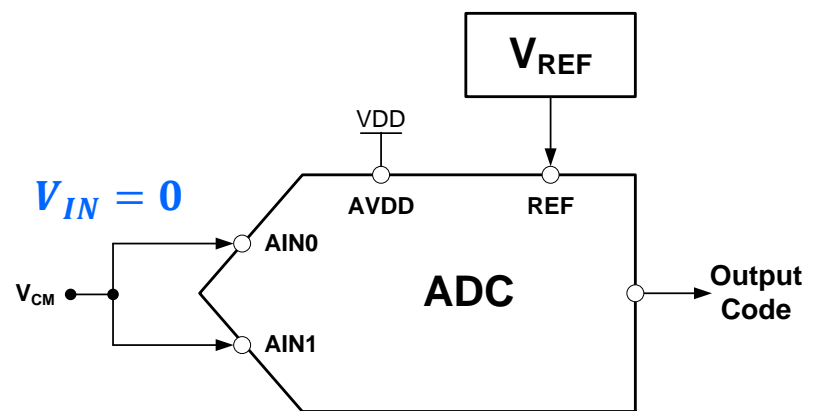

$$\text{Output Code} = V_{IN(RMS)} * \left(\frac{2^N}{V_{REF} + V_{N,REF(RMS)}} \right) \cong 0$$

ADC noise only



When you input a nonzero signal to the ADC, the ADC's output code includes some reference noise. This is the case for characterizing SAR or wideband delta-sigma ADCs using the input-sinewave test, as shown on the left. ADC datasheet parameters such as SINAD and SNR include some reference noise. Therefore, if your design uses a system similar to the ADC's testing setup, you can reasonably expect to achieve datasheet noise performance.

Comparatively, applying a zero volt input to characterize an ADC results in no reference noise seen in the output code. This is true for parameters that use the input-short method, such as effective resolution or noise-free bits, and is represented by the image and equation on the right.

However, real systems always need to be able to measure nonzero input voltages, so reference noise will always have some affect on the ADC's conversion result. Is there a way to generalize the impact that reference noise has on the system? The next slide derives an expression for this relationship by manipulating the output code equation shown here.

Deriving how VREF noise impacts the system

	Comment	Equation
Step 1	Output code equation	$V_{IN(RMS)} * \left(\frac{2^N}{V_{REF} + V_{N,REF(RMS)}} \right)$
	↓	↓
Step 2	Multiply by $\frac{V_{REF}}{V_{REF}}$	$\frac{V_{IN(RMS)}}{V_{REF}} * \left(\frac{2^N}{1 + \frac{V_{N,REF(RMS)}}{V_{REF}}} \right)$
	↓	↓
Step 3	Simplify using binomial approximation**	$\frac{V_{IN(RMS)} * 2^N}{V_{REF}} * \left(1 - \frac{V_{N,REF(RMS)}}{V_{REF}} \right)$
	↓	↓
Step 4	Distribute	$\frac{V_{IN(RMS)} * 2^N}{V_{REF}} - \frac{V_{IN(RMS)} * 2^N * V_{N,REF(RMS)}}{V_{REF}^2}$
		<div style="display: flex; justify-content: space-around;"> <div style="border: 1px dashed red; padding: 2px;"> $\frac{V_{IN(RMS)} * 2^N}{V_{REF}}$ <small>Signal (in codes)</small> </div> <div style="border: 1px dashed blue; padding: 2px;"> $\frac{V_{IN(RMS)} * 2^N * V_{N,REF(RMS)}}{V_{REF}^2}$ <small>VREF(noise) (in codes)</small> </div> </div>

Step 5: VREF(noise) in Volts (RTI)

$$= \frac{V_{IN(RMS)} * 2^N * V_{N,REF(RMS)}}{V_{REF}^2} * \frac{V_{REF}}{2^N}$$

$$= \frac{V_{IN(RMS)}}{V_{REF}} * V_{N,REF(RMS)}$$

**https://en.wikipedia.org/wiki/Binomial_approximation



The table on the left begins with the output code equation shown on the previous slide, restated here in Step 1. The goal is to manipulate this equation such that there are distinct signal and noise terms. To accomplish this, Step 2 multiplies the equation by VREF divided by VREF. This does not change the result of the output code equation as long as you assume that VREF is greater than zero.

Next, simplify the modified equation in Step 2 by employing the binomial approximation in Step 3. If you would like to learn more about this topic and how this transformation is performed, review the information provided at the link in the top right.

Once this is completed, distributing the VIN-divided-by-VREF term results in the equation shown in Step 4. This equation has two parts: the code value for the input signal, highlighted in red, and the code value for the reference noise, highlighted in blue. Note that reference noise only shows up in the second term in this equation, which is the desired outcome.

Finally, take this second term and convert it back to volts using the equation in Step 5 on the right. Multiplying by the reference voltage and dividing by the maximum code value yields the equation highlighted in yellow. The voltage reference's input referred noise is the total reference noise scaled by the ratio of the input signal to the reference voltage. Or, in practical terms, the more of the ADC's full-scale range that you use, the more reference noise you let into

your system.

Let's plot this equation as a function of input signal to better understand the result.

Plotting VREF noise for DC signals

System Parameters

$$V_{REF} = 2.5 \text{ V}$$

$$V_{N,REF (RMS)} = 10 \mu\text{V}_{RMS}$$

$V_{IN (RMS)}$ = DC input swept from 0 V to +FS

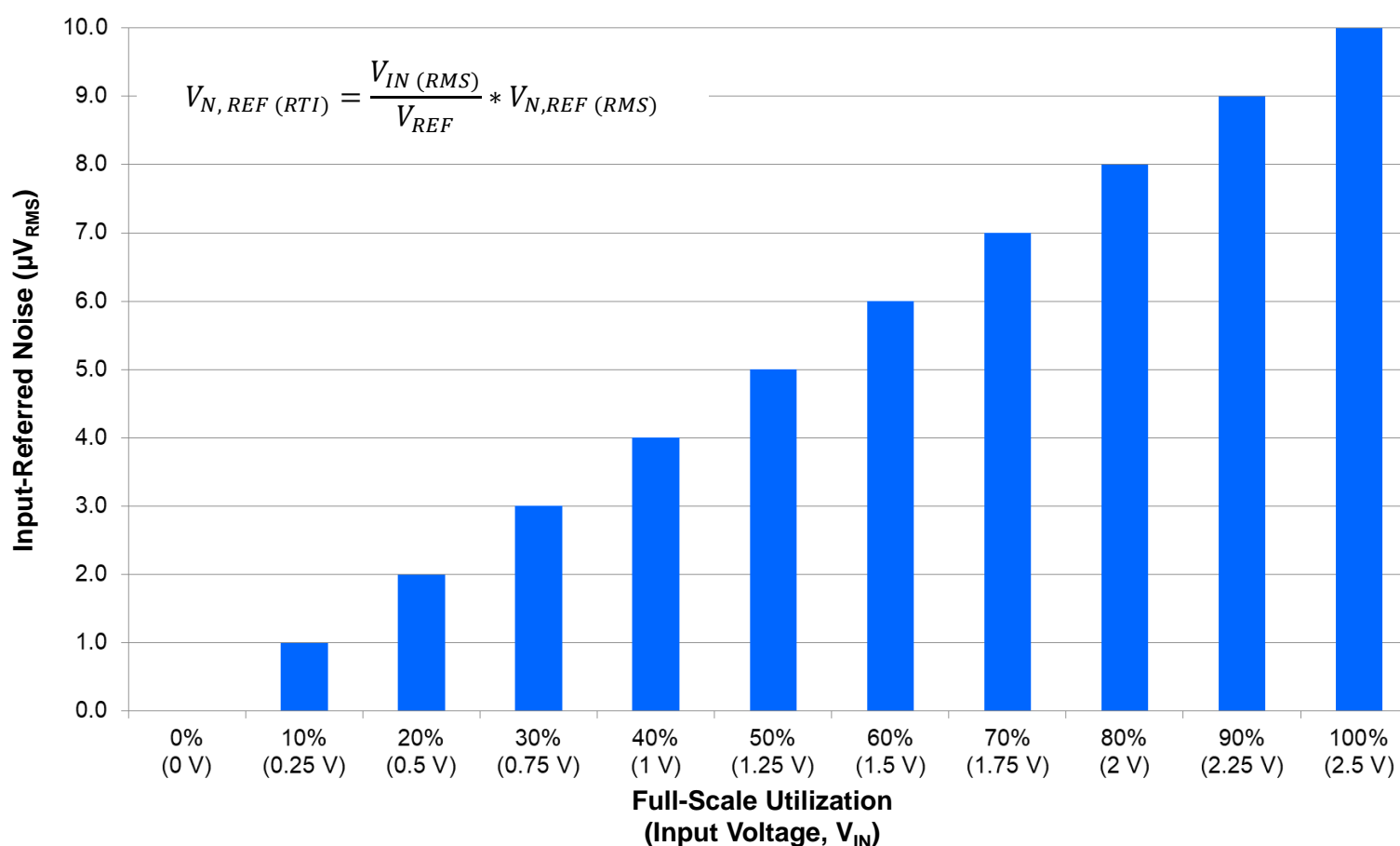

For this example, let's assume the reference voltage is 2.5 volts, the total reference noise is 10 microvolts RMS, and the input is a DC signal that is swept from zero volts to positive full-scale. These conditions are summarized on the left.

The plot on the right represents the amount of reference noise passed to the system as the input signal changes in 0.25 volt increments. As shown, the changing input signal can also be quantified by how much of the full-scale range is used, or full-scale utilization. Given the equation in the top left corner of the plot, the reference noise scales linearly as the input increases. For example, a zero volt input signal does not pass any reference noise to the system, while a 1 volt input allows 40%, or 4 microvolts RMS, of the reference noise into the signal chain. At V_{IN} equals 2.5 volts, or a full-scale input, the system sees the total reference noise of 10 microvolts RMS since the RMS value of a DC signal is just the DC signal.

AC signals follow the exact same relationship, though the math can be more complex since these terms need to be expressed in RMS. However, you can verify this relationship using simulation tools.

Simulating VREF noise for AC signals

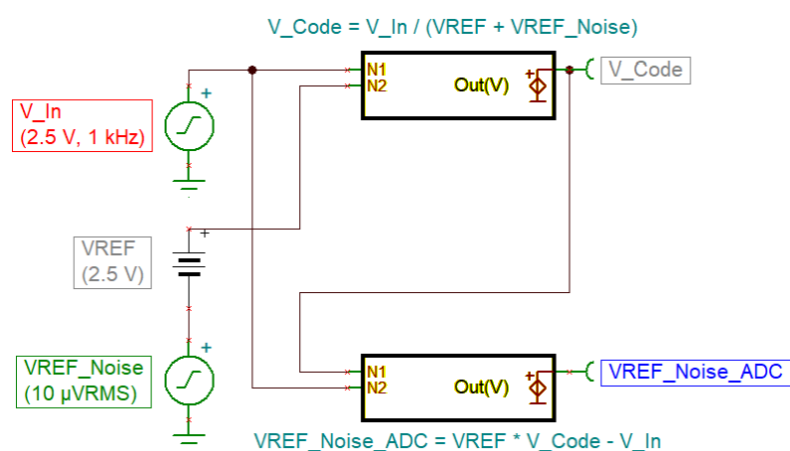

$$\begin{aligned}
 V_{N,REF(RTI)} &= \frac{V_{IN(RMS)}}{V_{REF}} * V_{N,REF(RMS)} \\
 &= \frac{2.5 V}{2.5 V * \sqrt{2}} * 10 \mu V_{RMS} \\
 &= 7.08 \mu V_{RMS}
 \end{aligned}$$

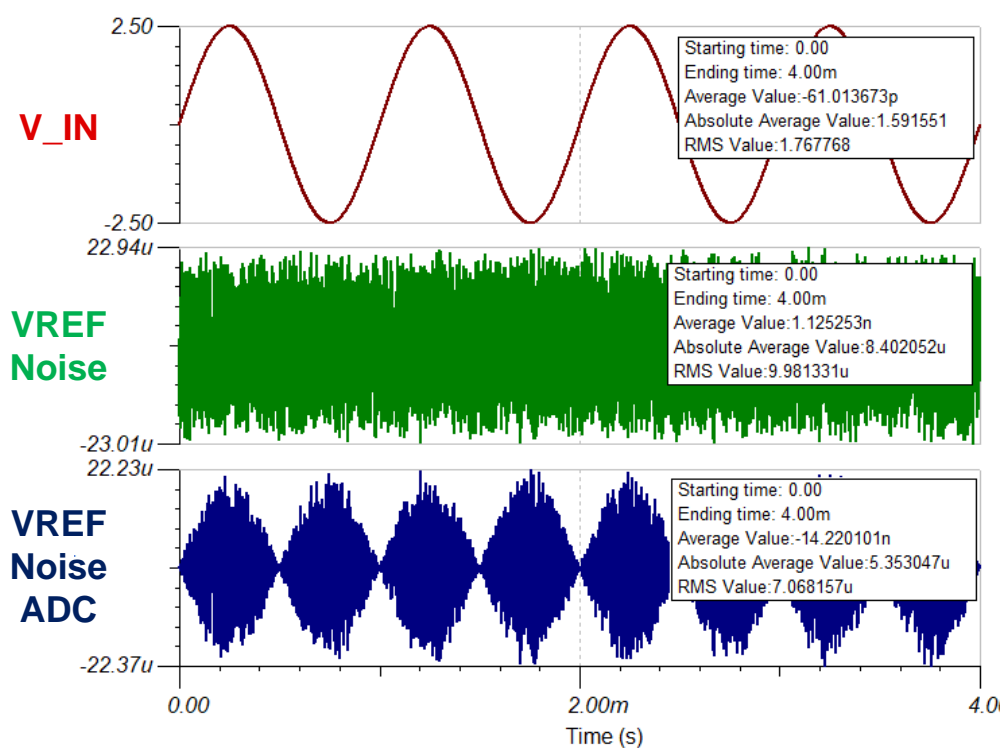

Similar to the previous example, the schematic on the left measures a 2.5 volt peak, 1 kilohertz sinewave input against a 2.5 volt DC reference voltage with a 10 microvolt RMS broadband noise component. The sinewave input signal's RMS value is calculated to be 2.5 volts divided by the square root of 2, though the reference noise equation applies equally to other input signal types such as square or triangle waves.

Plugging all of these values into the reference noise equation yields an expected output noise of 7.08 microvolts RMS as highlighted in yellow.

To verify the expected result with simulated data, two controlled sources are used to plot this system's code voltage and the resulting VREF noise as a function of time. The output equations for each controlled source are shown in the schematic, while the plots on the right show in the input signal as well as compare the reference noise contributed by the source and the reference noise seen by the ADC. Specifically, the green plot confirms that the reference source's noise is broadband in nature and has a value of 10 microvolt RMS, while the blue plot confirms the reference noise seen by the ADC is 7.08 microvolts RMS. You can also see from the shape of each plot how the sinusoidal input modulates the reference noise signal, removing some of the noise power and lowering the overall reference noise seen by the ADC. Therefore, even with a full-scale sinusoidal input, not all of the reference noise is passed to the ADC.

Now that we have confirmed the reference noise equation, let's move on to understand how to calculate voltage reference noise

Calculating reference noise (REF60xx)

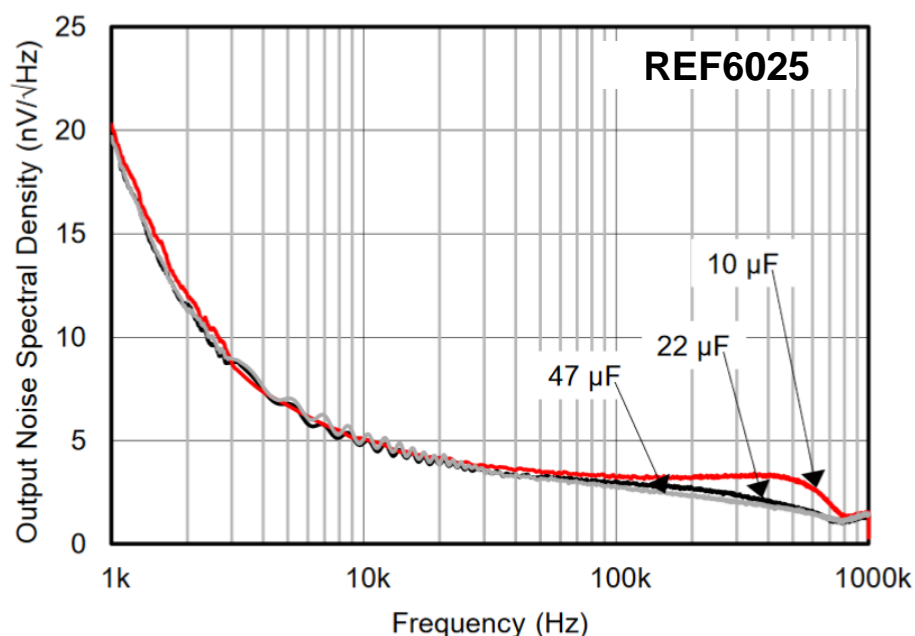

PARAMETER	TEST CONDITIONS	MIN	TYP	MAX	UNIT
NOISE					
Total integrated noise	$C_L = 22 \mu\text{F}$		5		μV_{RMS}
	$C_L = 47 \mu\text{F}$		5		
Low frequency noise	$0.1 \text{ Hz} \leq f \leq 10 \text{ Hz}$		3		$\mu\text{V}_{\text{PP}}/\text{V}$

$$\text{REF6025}_{1/f \text{ noise}} = 3 \frac{\mu\text{V}_{\text{PP}}}{\text{V}} * 2.5 \text{ V} = 7.5 \mu\text{V}_{\text{PP}} (\sim 1.14 \mu\text{V}_{\text{RMS}})$$

For REF6025 noise at other frequencies e.g. 100 Hz, use equations** or simulation

**View the Precision Labs modules on amplifier noise & effective noise bandwidth to learn how to calculate total noise



As an example, let's use the REF6025, a low noise 2.5 volt reference with integrated buffers. On the left is the noise spectral density plot from the REF6025's datasheet, while on the right is the portion of the electrical characteristics table describing the output noise.

One important feature of the REF6025's noise spectral density plot is that it has significant low-frequency noise as well as a flatter, broadband noise region. For the simulations on the previous slide, we assumed the reference noise was entirely broadband to keep the analysis simple. This does not change the previously-derived reference noise equation, but it does complicate the RMS voltage noise calculations. Fortunately, the low frequency noise is called out in the electrical characteristics table and is calculated here as 7.5 microvolts of peak to peak noise from 0.1 hertz to 10 hertz. Assuming a crest factor of 6.6, the resulting RMS voltage noise is approximately 1.14 microvolts RMS.

If your reference path's effective noise bandwidth was any other frequency, for example 100 Hz, you would have to calculate the reference's total noise output using the plot on the left. However, you calculate reference noise using the same methods as you would use to calculate amplifier noise, so there are no new equations to learn once you've reviewed the amplifier noise Precision Labs modules. Moreover, you can use the information in the Precision Labs module on effective noise bandwidth to learn how to calculate this parameter for any signal path.

Additionally, you can use simulation tools to help calculate the reference noise seen by your system. The next slide discusses this topic in more detail.

Simulating reference noise (REF60xx)

Simulated circuit

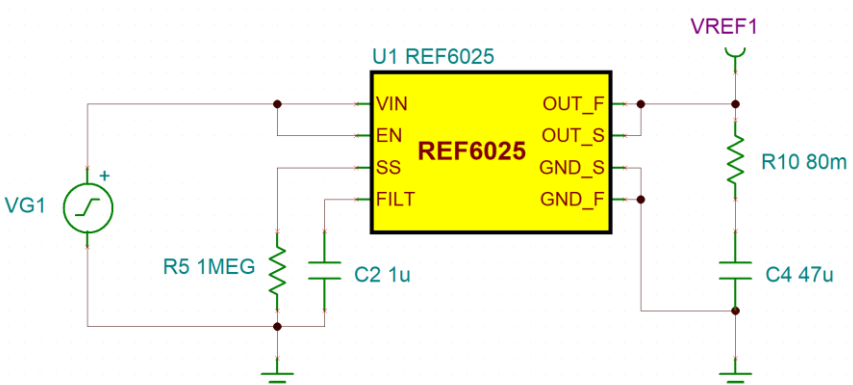

Total output noise @ 10 Hz & 100 Hz

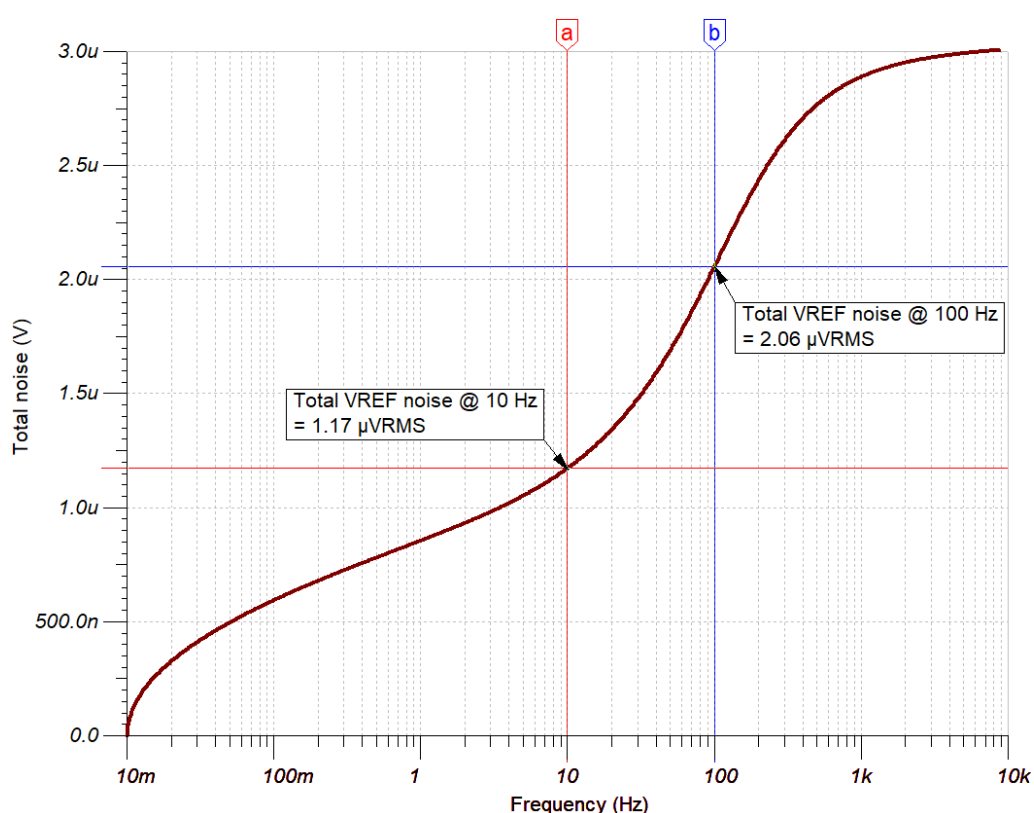

If a spice model is available for your component, you can generally find it on the device's product folder on TI.com. The REF6025 model is shown here on the left, with basic connections included.

Running a total noise analysis of the circuit on the left yields the total RMS voltage noise plot on the right. The noise at 10 hertz bandwidth is called out at 1.17 microvolts RMS. This is very similar to the 1.14 microvolts RMS value calculated on the previous slide, providing confidence in the simulated results. Moreover, you can now use the plot on the right to quickly check the noise at any bandwidth. For example, the total noise at 100 hertz is 2.06 microvolts RMS, as this bandwidth was also discussed on the previous slide.

Since we have analyzed the effects of broadband noise only as calculated and simulated total noise, let's take a closer look at the effects of low-frequency noise before moving on to ADC performance analysis

Effects of low-frequency (1/f) reference noise

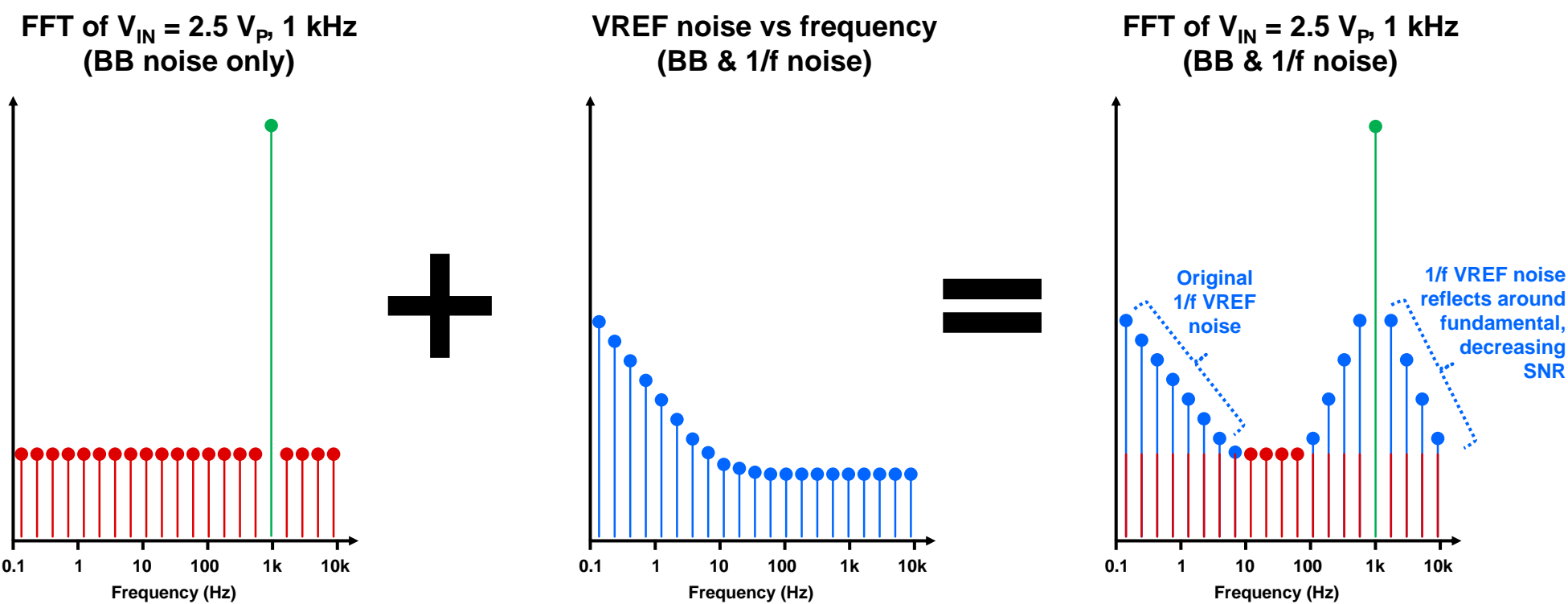

Low-frequency VREF noise often dominates the overall system noise performance



When we initially confirmed the reference noise equation using simulation tools, we used a purely broadband noise source to keep the analysis simple. If the noise were purely broadband, performing an FFT on the captured data would result in a plot similar to the one shown on the left: a distinct fundamental spike at the 1 kilohertz input signal frequency and a relatively flat noise floor.

However, voltage references typically include a significant low-frequency or 1/f noise region, similar to the REF6025's noise spectral density shown previously. This is represented by the plot in the middle. Since this noise is not Gaussian in nature, it does not distribute uniformly throughout the frequency spectrum. Moreover, the very low-frequency nature of this noise makes it challenging to filter out.

Therefore, the reference's 1/f noise shows up in the low frequency region as expected, but also tends to reflect around the fundamental, causing the skirting effect shown in the plot on the right. This increased noise around the fundamental frequency can reduce the overall system SNR, and often dominates the overall system noise performance compared to the voltage reference's broadband noise. Carefully consider the 1/f noise magnitude of your voltage reference when choosing a component.

Now you are ready to apply the information in this module to the signal chain shown on the first slide. Check out the next Precision Labs module to learn more about how reference noise affects ADC performance.

Thanks for your time! Please try the quiz.

That concludes this video. Thank you for watching. Please try the quiz to check your understanding of this video's content.

Quiz: Intro to reference noise in ADC systems

1. How will applying a DC input signal impact the system noise due to the voltage reference?
 - a. The input signal has no impact on the reference noise
 - b. The reference noise at the output will be directly proportional to the DC input signal
 - c. Reference noise is only impacted by AC input signals
 - d. The reference noise at the output will be inversely proportional to the DC input signal

Quiz: Intro to reference noise in ADC systems

1. How will applying a DC input signal impact the system noise due to the voltage reference?
 - a. The input signal has no impact on the reference noise
 - b. The reference noise at the output will be directly proportional to the DC input signal
 - c. Reference noise is only impacted by AC input signals
 - d. The reference noise at the output will be inversely proportional to the DC input signal

Quiz: Intro to reference noise in ADC systems

2. (T/F) When applying a sinusoidal input, the output reference noise will be proportional to the RMS of the sine wave?
- a. True
 - b. False

Quiz: Intro to reference noise in ADC systems

2. (T/F) When applying a sinusoidal input, the output reference noise will be proportional to the RMS of the sine wave?
- a. True
 - b. False

Quiz: Intro to reference noise in ADC systems

3. How does the $1/f$ noise in the voltage reference show up in the ADC output spectrum?
- a. It shows up in the same frequency range in the output spectrum as it does in the reference noise
 - b. It shows up as skirts on any AC signal applied to the system
 - c. Both A & B

Quiz: Intro to reference noise in ADC systems

3. How does the $1/f$ noise in the voltage reference show up in the ADC output spectrum?
- a. It shows up in the same frequency range in the output spectrum as it does in the reference noise
 - b. It shows up as skirts on any AC signal applied to the system
 - c. Both A & B

Thanks for your time!



© Copyright 2020 Texas Instruments Incorporated. All rights reserved.

This material is provided strictly "as-is," for informational purposes only, and without any warranty.
Use of this material is subject to TI's [Terms of Use](#), viewable at TI.com

