

PWM Basics Overview

TI Precision Labs – Timers

Presented by J.D. Crutchfield

Prepared by Leo Estevez



PWM history and overview

- Pulse refers to a short period of time over which the signal will be asserted.
- Width refers to the duration of time over which the signal is asserted.
- Modulation refers to changes in the pulse width over time.

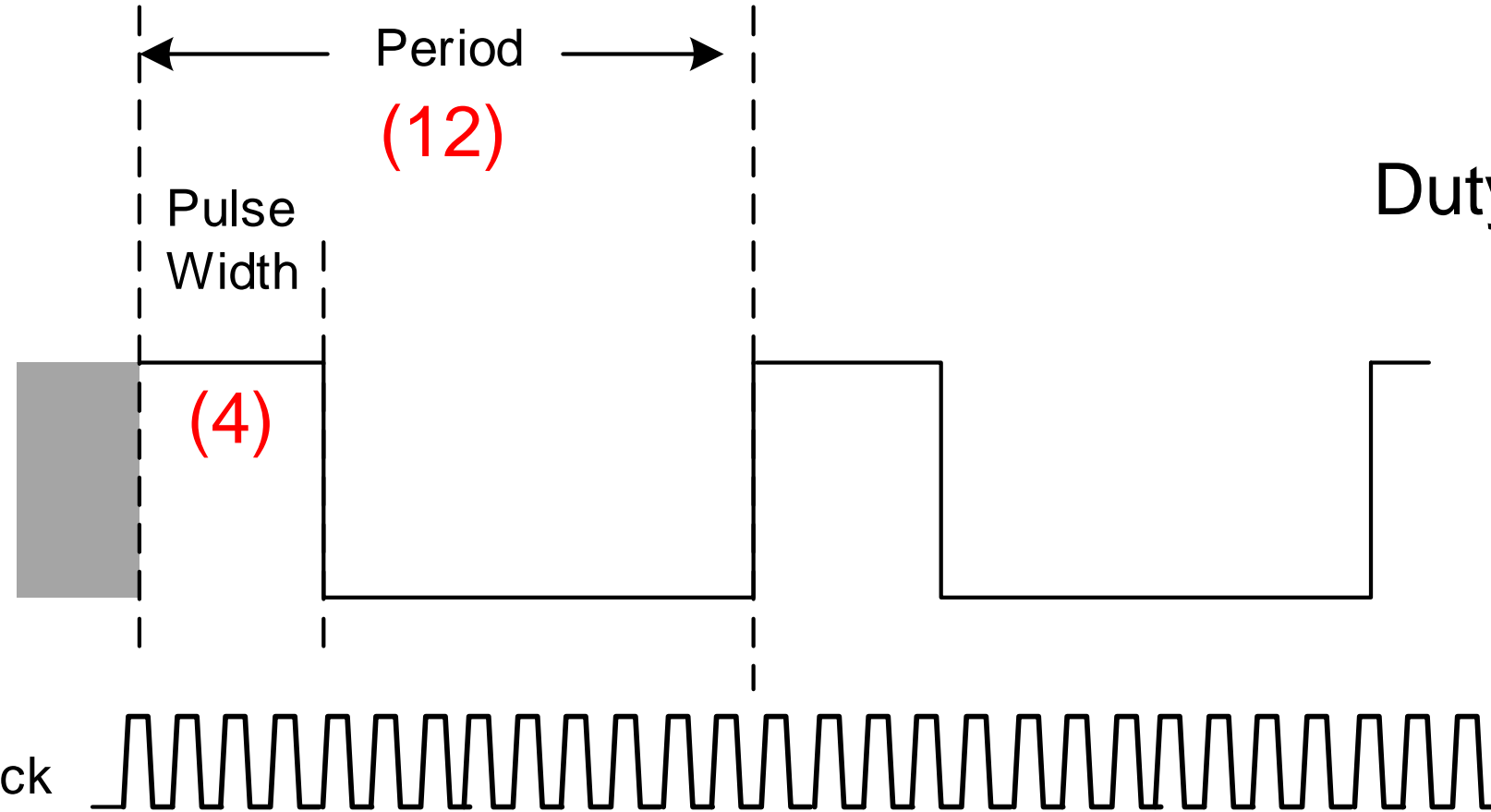

$$\text{Duty Cycle} = (\text{Pulse Width}/\text{Period}) * 100$$

$$\text{Duty Cycle} = (4/12) * 100 = \sim 33\%$$

PWM Applications

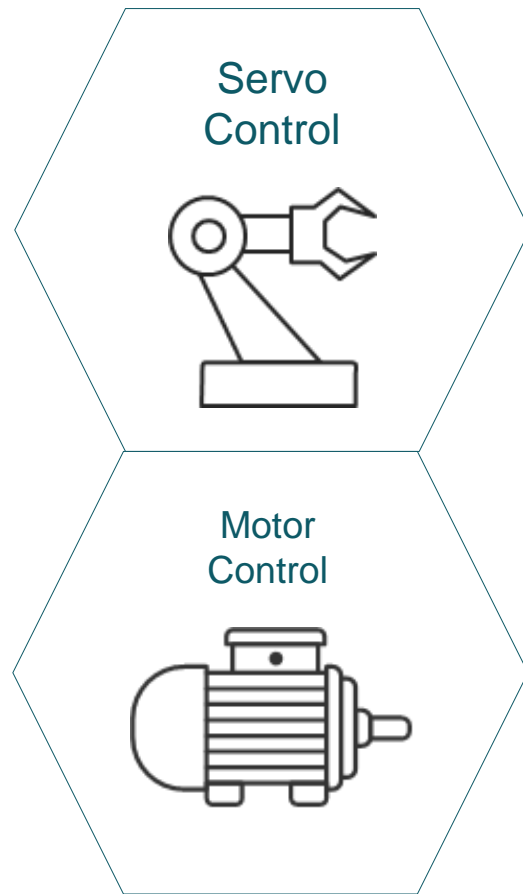

Factory Automation

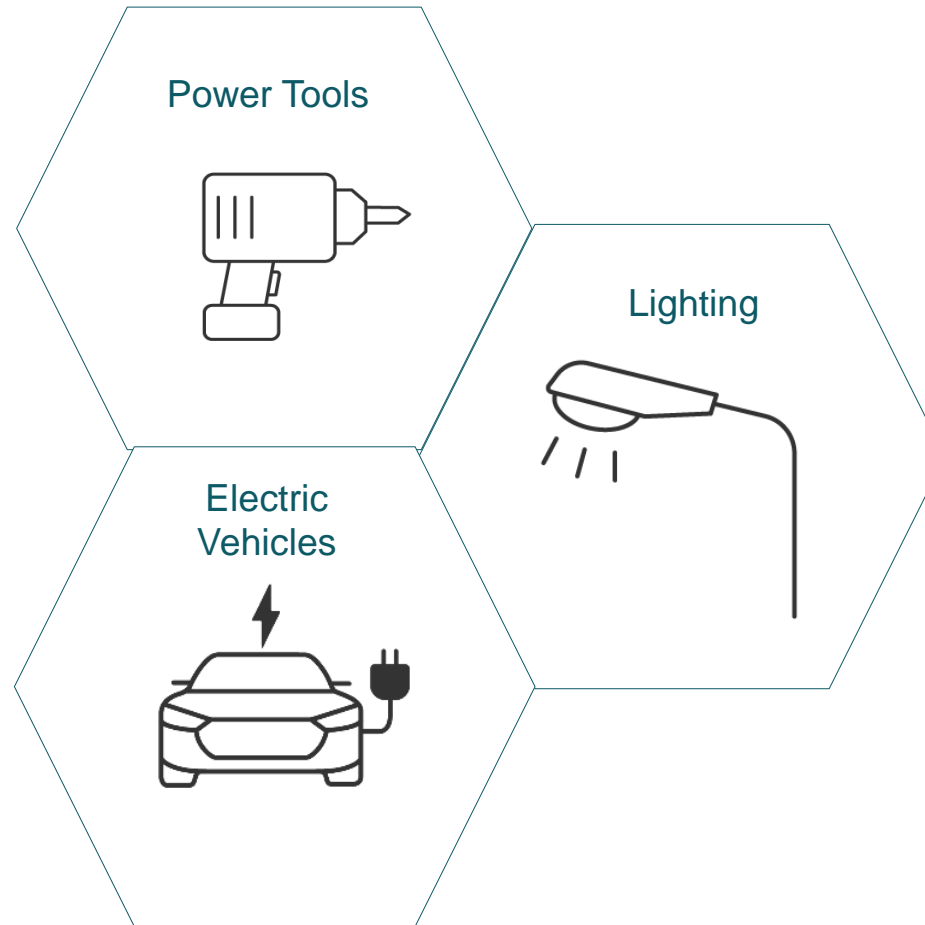

Battery Operated

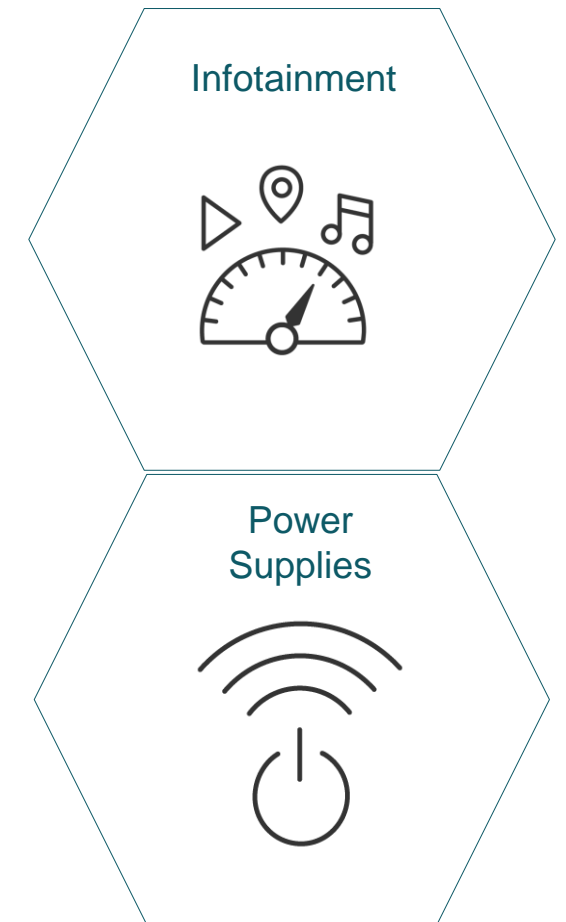

Consumer Electronics

PWM Pin Configuration

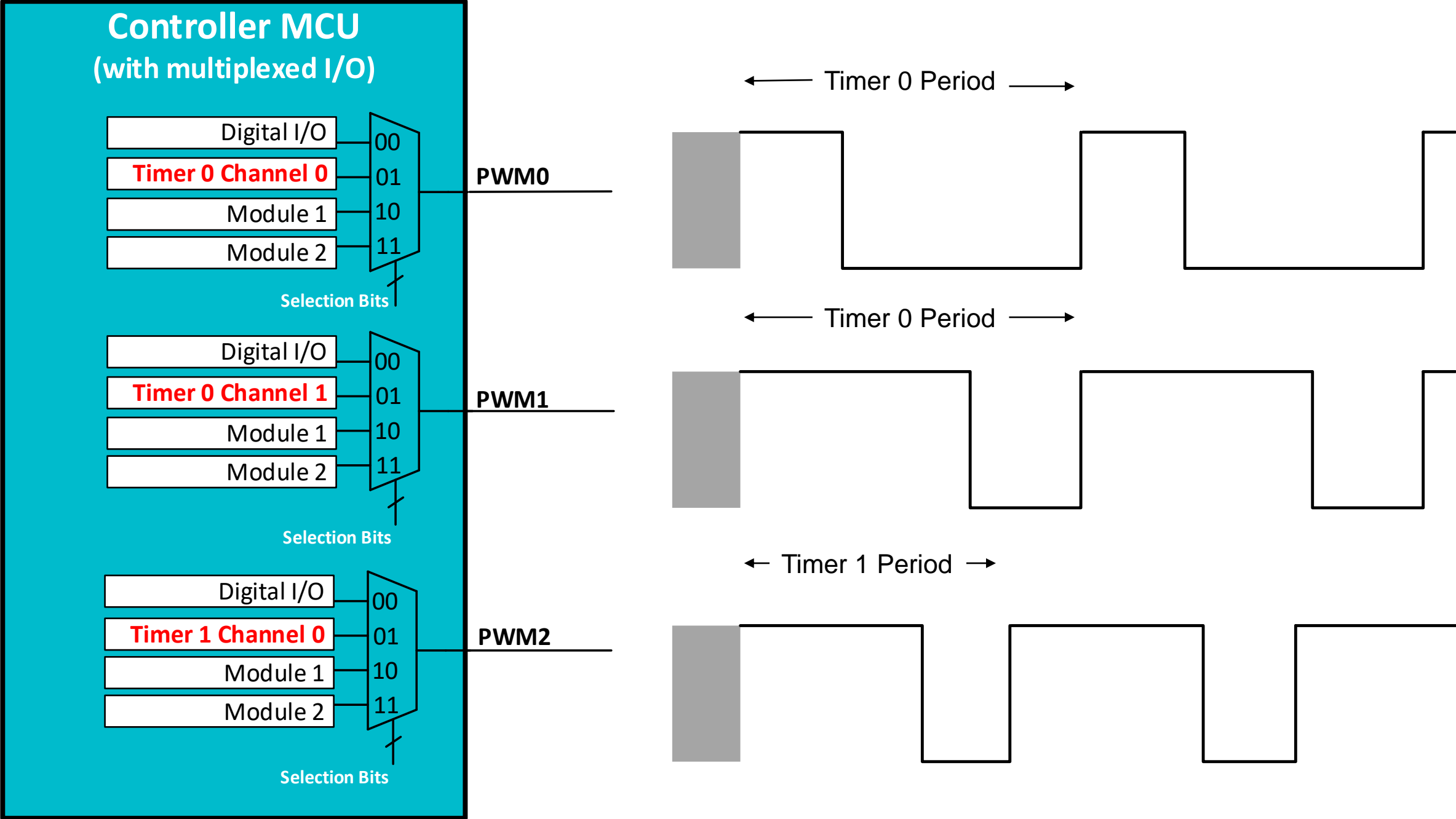

PWM Timer Operation

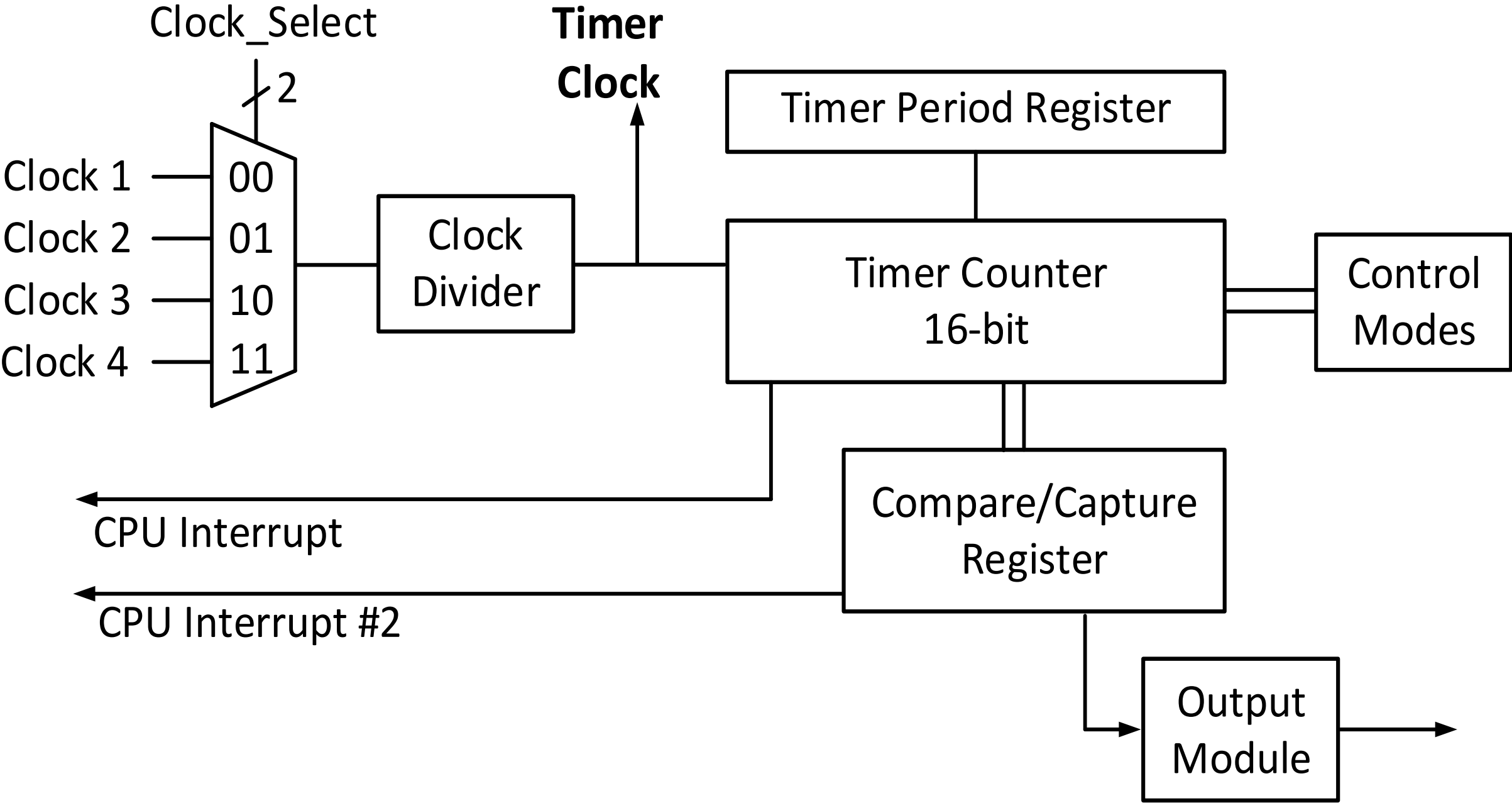

PWM Single Channel Operation

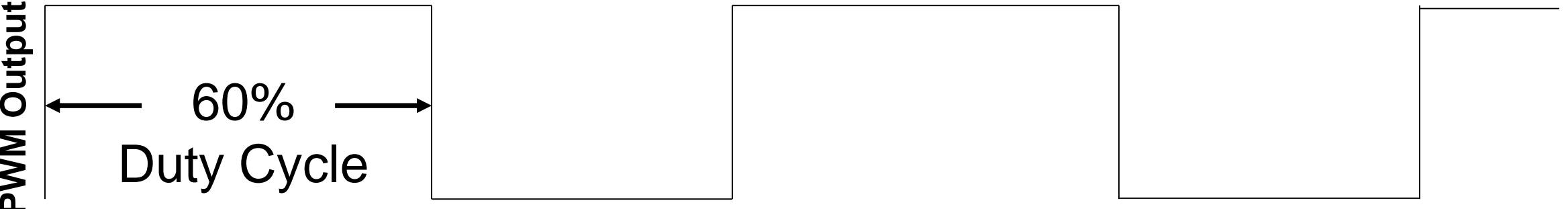
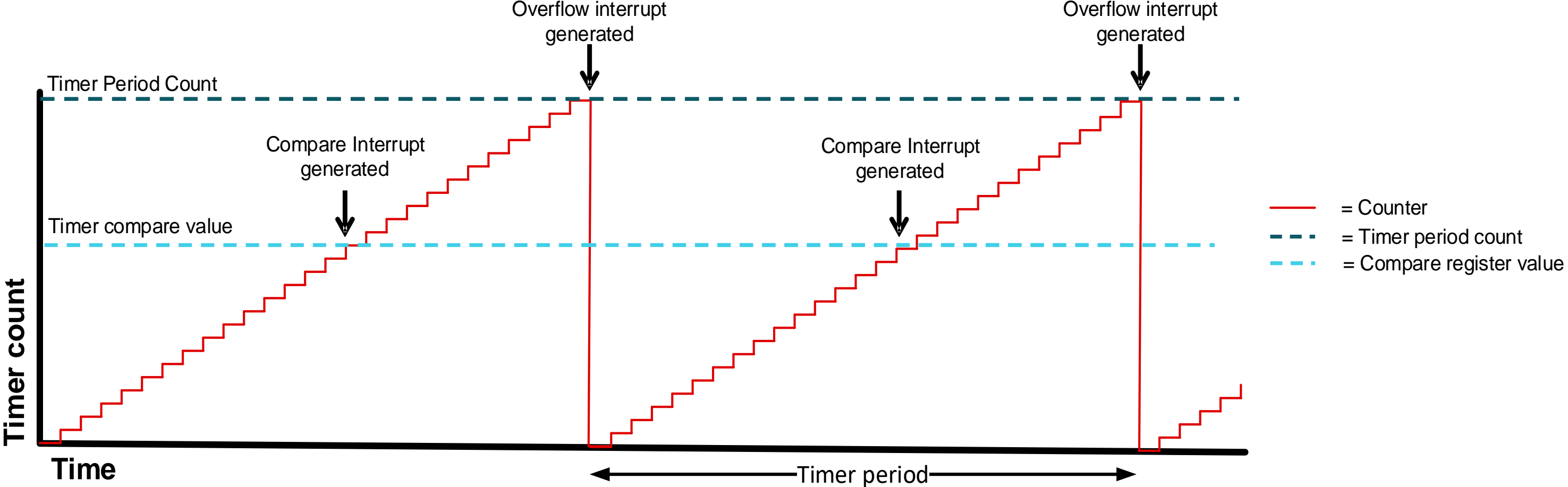

PWM Single Channel Operation

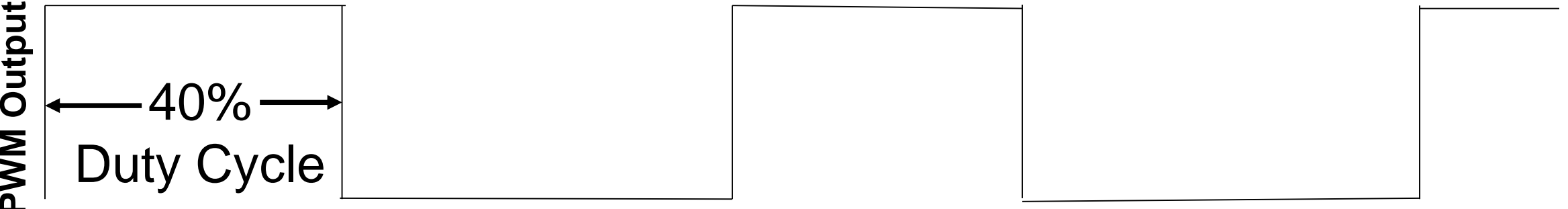
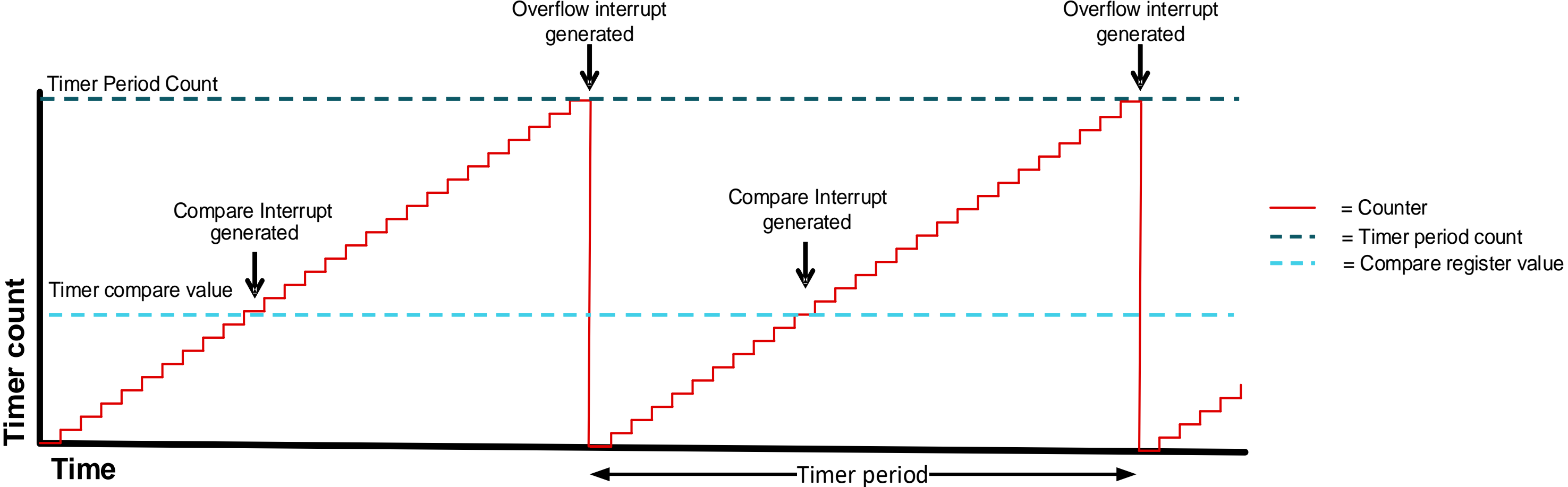

PWM Single Channel Operation

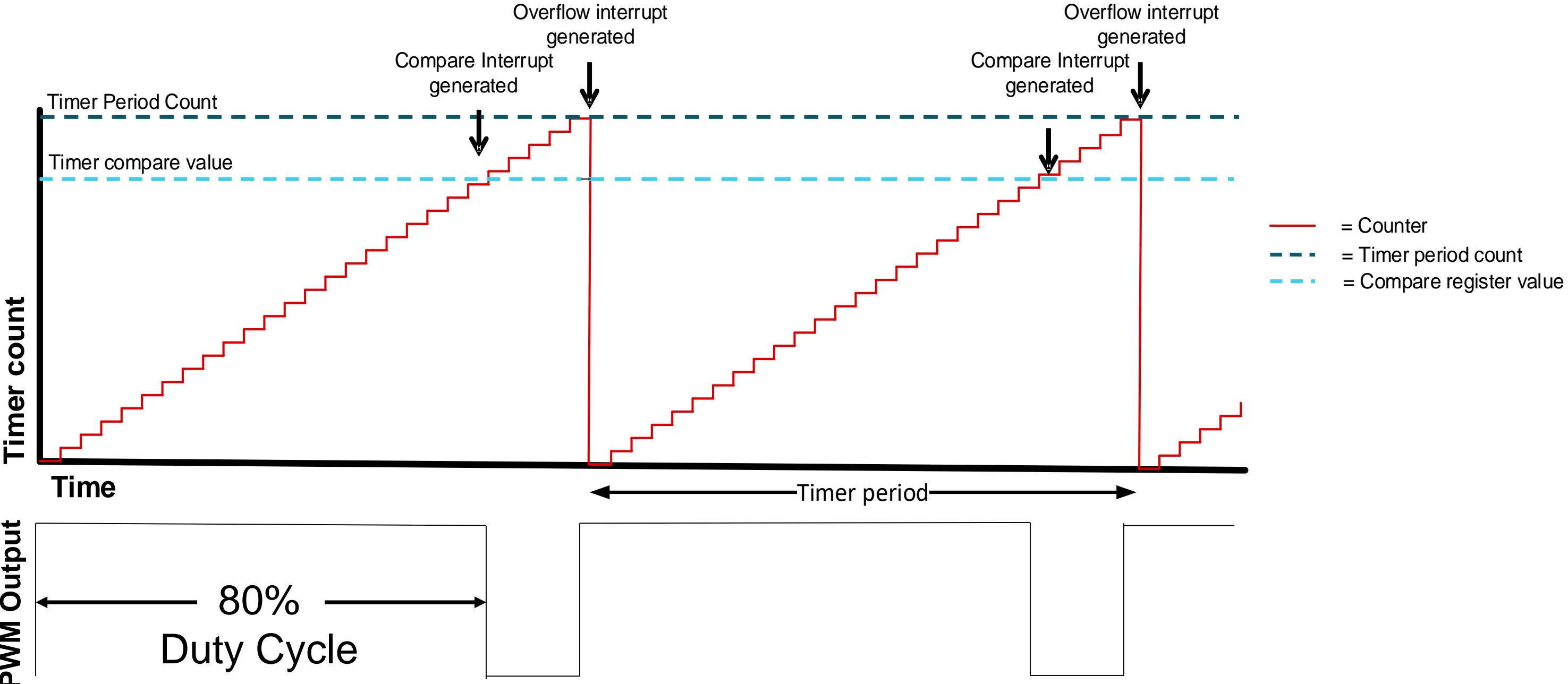

Edge Aligned PWM Channels

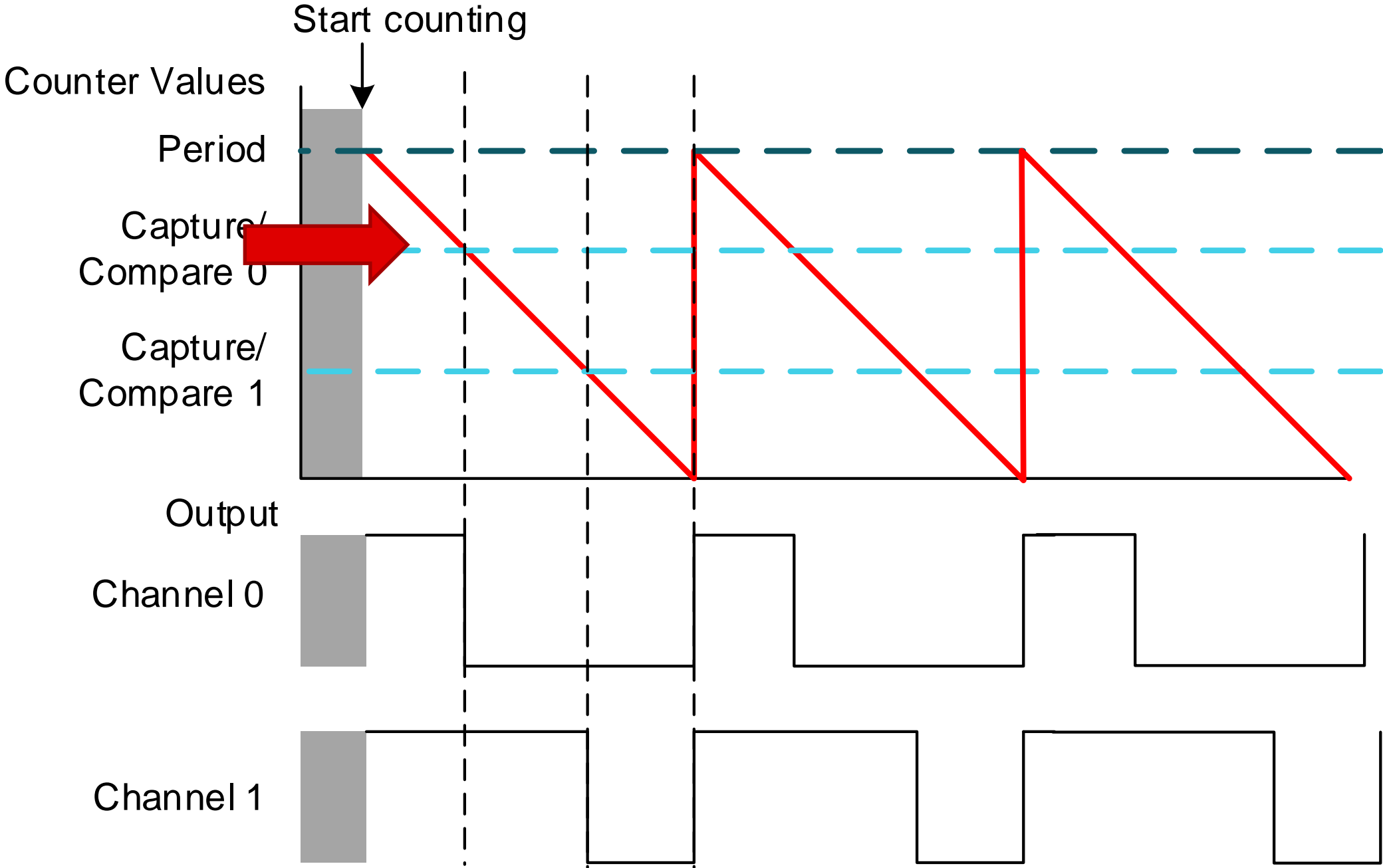

Center Aligned PWM Channels

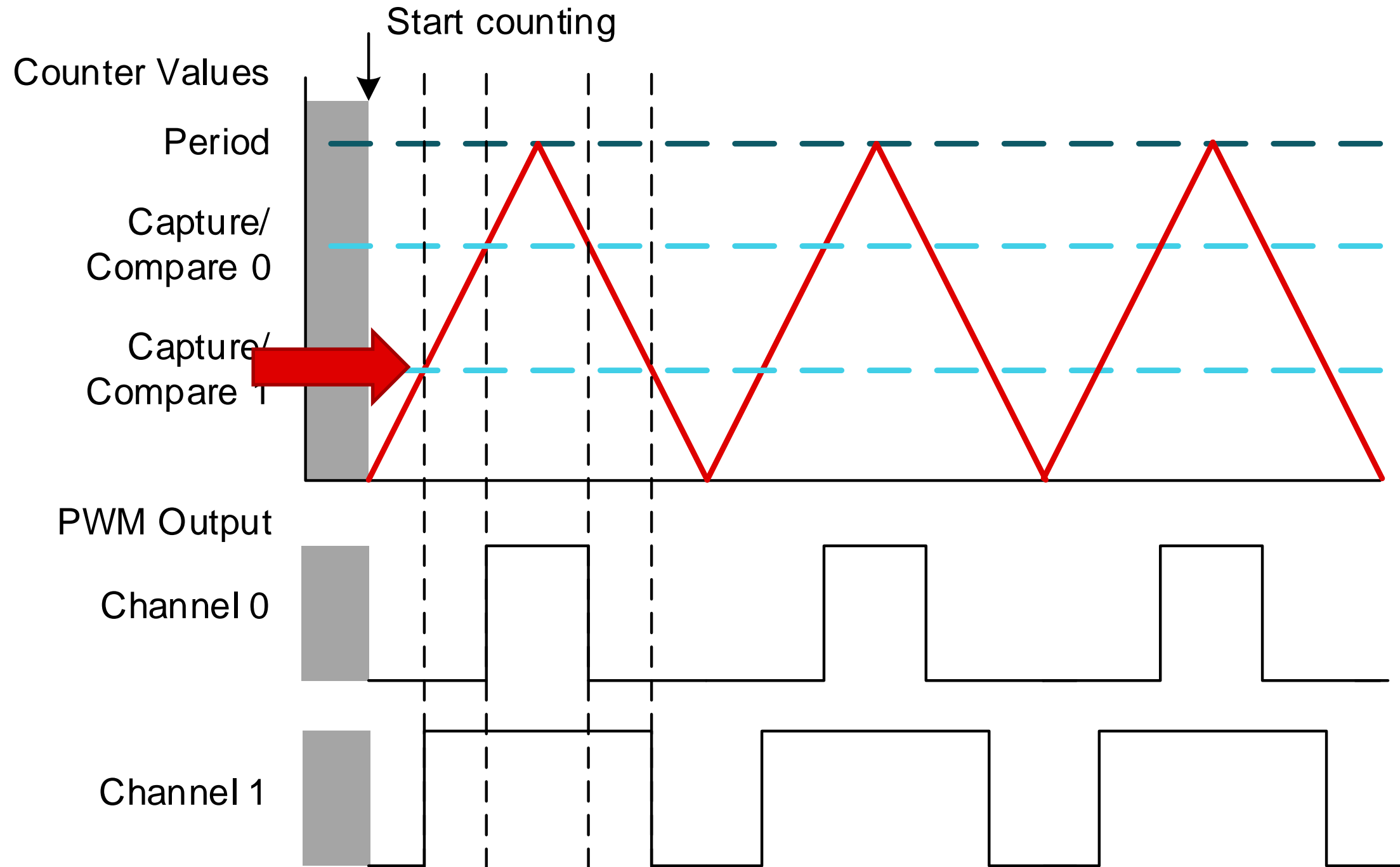

PWM Summary

- Applications
- Pin Configuration
- Operation
- Edge Aligned PWM
- Center Aligned PWM

To find more <insert product name>
technical resources and search
products, visit [**ti.com/<insert product
portal>**](https://ti.com/<insert product portal>)