

# AC & DC Specifications:

offset error, gain error, CMRR, PSRR, SNR, THD

TIPL 4002  
TI Precision Labs – ADCs

Created by Art Kay

Presented by Peggy Liska



# Offset & Gain Error

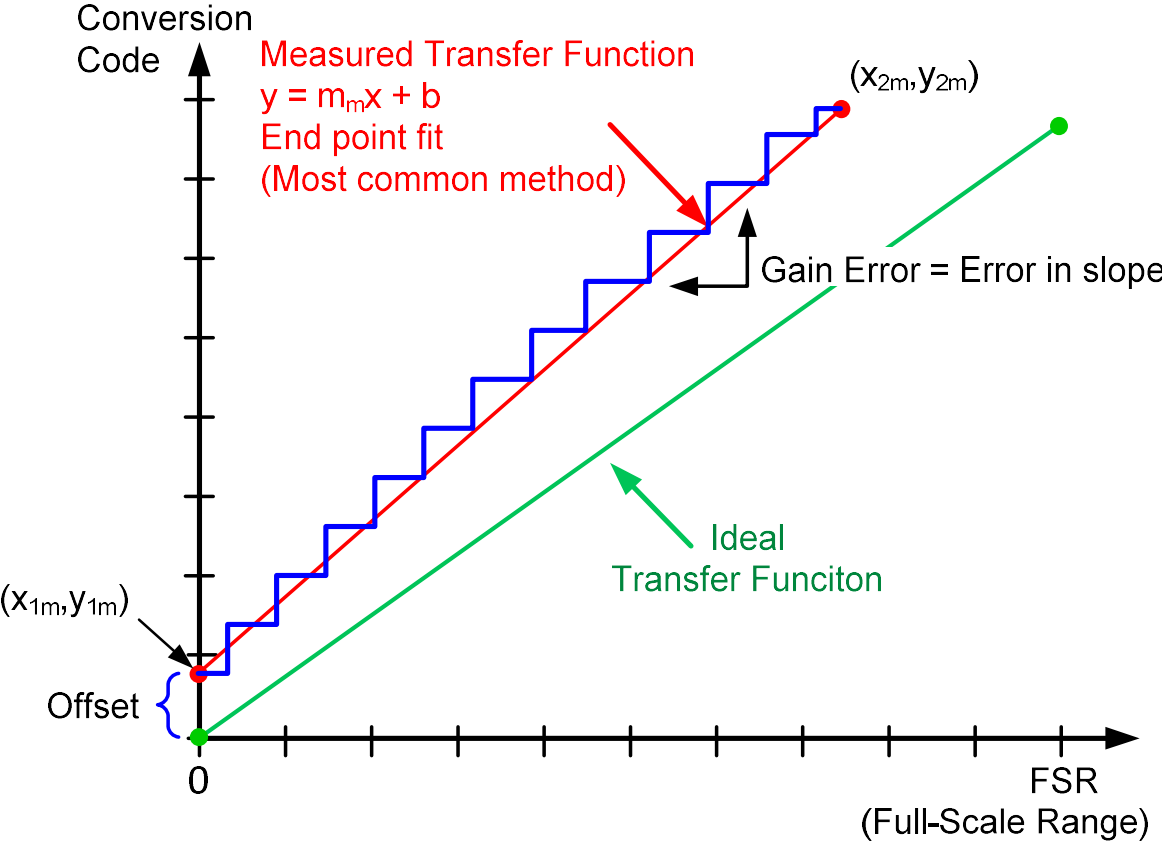

Offset and Gain Error based on End point fit:

Straight Line Fit  $y = m_m \cdot x + b$

Measured Transfer Function  $m_m = \frac{y_{2m} - y_{1m}}{x_{2m} - x_{1m}}$

Offset Error  $b = y - m_m \cdot x$

Gain Error  $E_G = \left( \frac{m_m - m_i}{m_i} \right) \cdot 100\%$   
 ( $m_i$  is the ideal transfer function)

# Common Mode Rejection & Power Supply Rejection

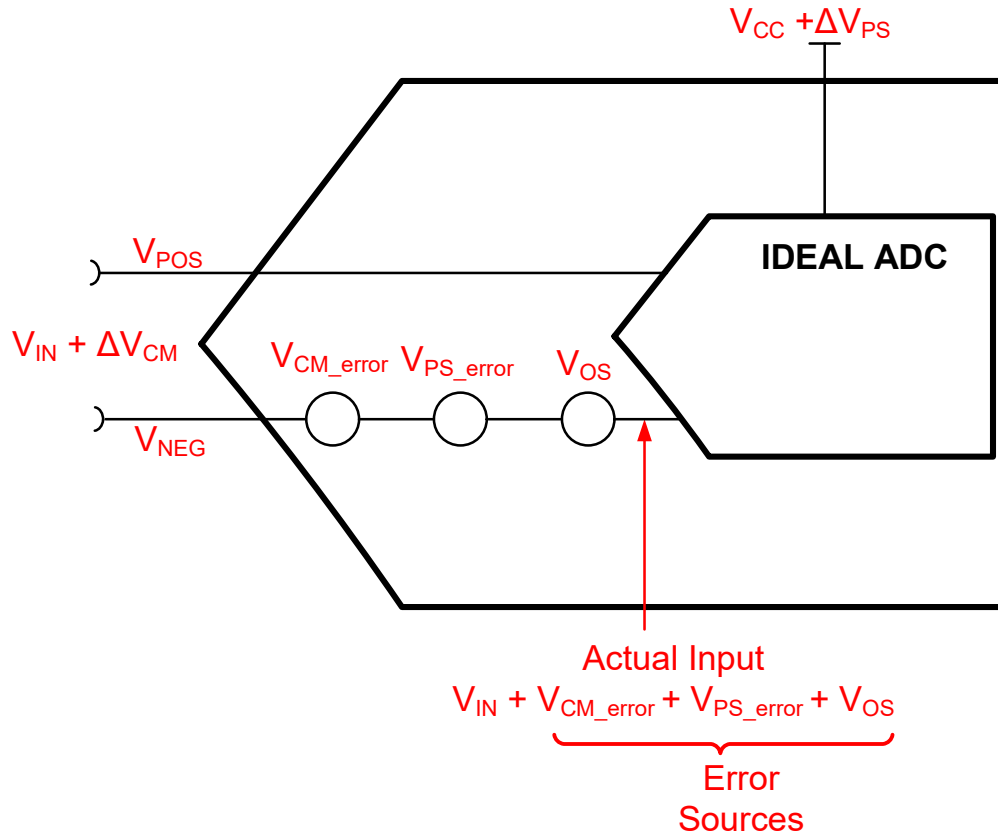

$$V_{CM} = \left( \frac{V_{POS} + V_{NEG}}{2} \right)$$

$$CMRR(dB) = -20 \cdot \log \left( \frac{\Delta V_{CM\_error}}{\Delta V_{CM}} \right)$$

$$\Delta V_{CM\_error} = \Delta V_{CM} \cdot 10^{\left[ \frac{-CMRR(dB)}{20} \right]}$$

$$PSRR(dB) = -20 \cdot \log \left( \frac{\Delta V_{PS\_error}}{\Delta V_{PS}} \right)$$

$$\Delta V_{PS\_error} = \Delta V_{PS} \cdot 10^{\left[ \frac{-PS(dB)}{20} \right]}$$

# Common Mode Rejection - CMRR

AVDD = 3V, DVDD = 3V, VREF = 5V, VCM = 2.5V, AND  $f_{\text{sample}} = 1\text{Mpsps}$  unless otherwise noted

PARAMETER	TEST CONDITION	MIN	TYP	MAX	UNIT
<b>SYSTEM PERFORMANCE</b>					
<b>CMRR</b>	Common-mode rejection ratio	90	100		dB

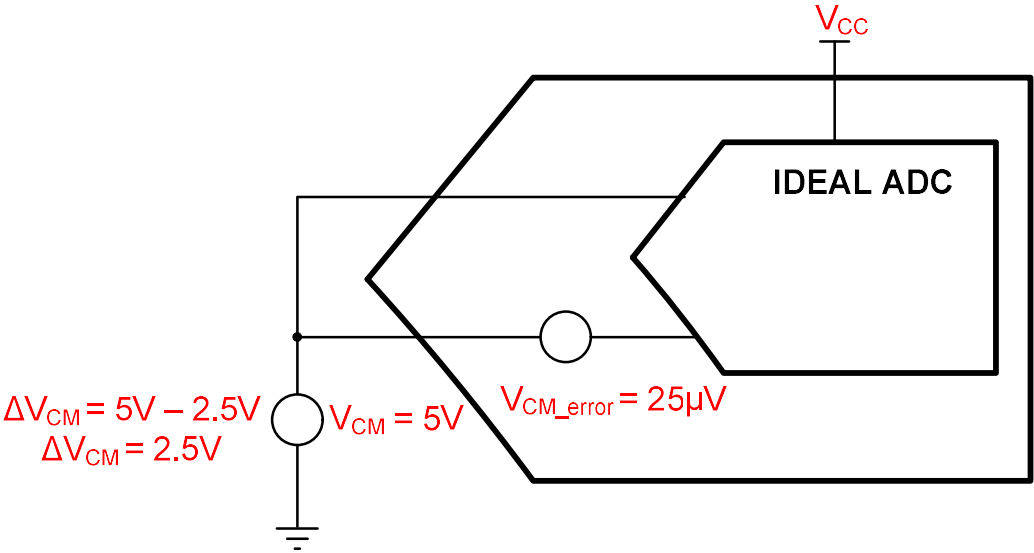

$$V_{CM} = \left( \frac{V_{POS} + V_{NEG}}{2} \right)$$

$$\Delta V_{CM\_error} = \Delta V_{CM} \cdot 10^{\left[ \frac{-CMR (dB)}{20} \right]}$$

$$\Delta V_{CM\_error} = 2.5V \cdot 10^{\left[ \frac{-100dB}{20} \right]} = 25\mu V$$

# Power Supply Rejection - PSRR

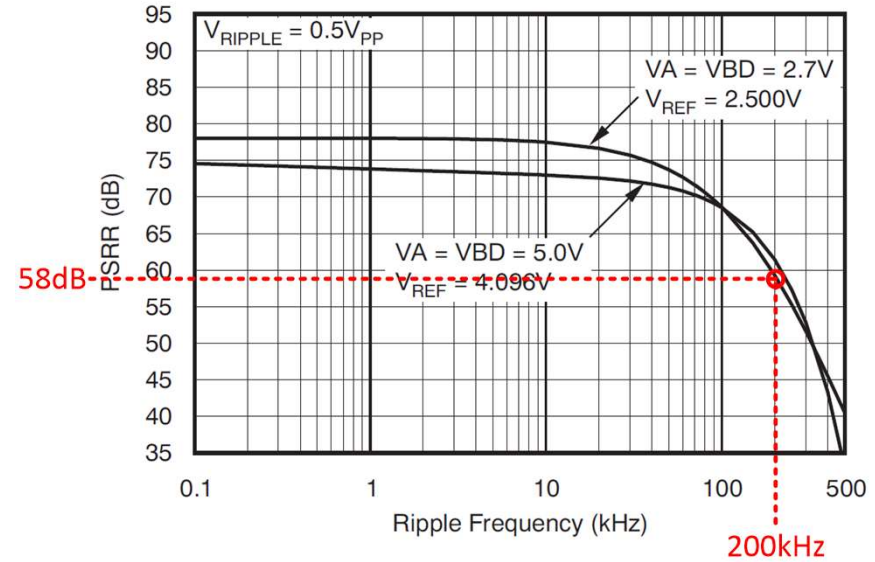
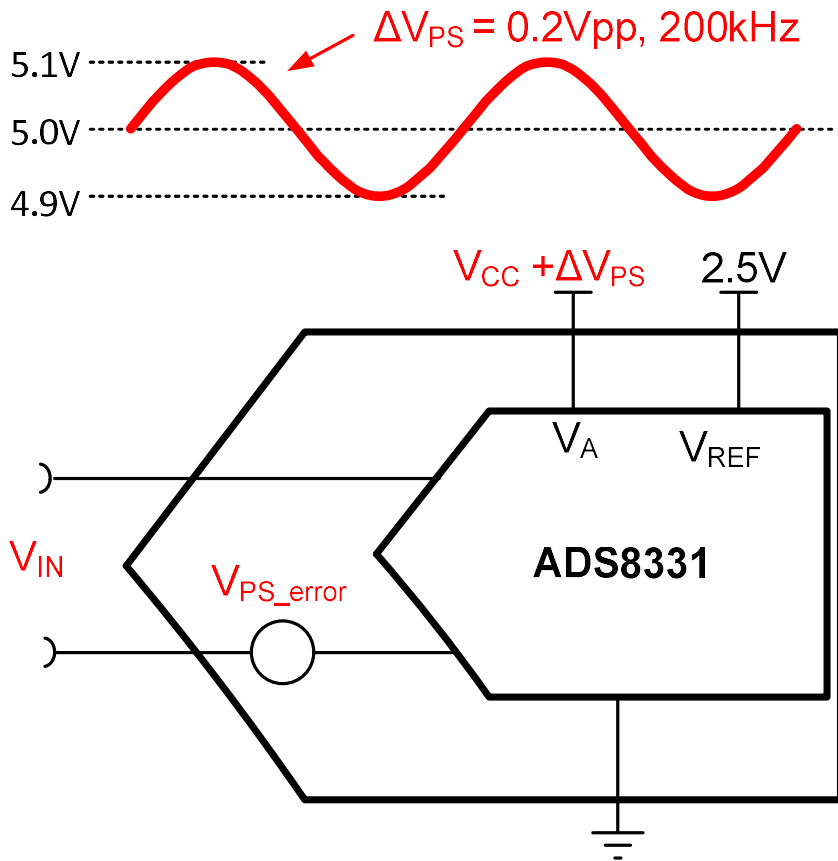

$$\Delta V_{PS\_error} = \Delta V_{PS} \cdot 10^{\left[\frac{-PSR (dB)}{20}\right]}$$

$$\Delta V_{PS\_error} = 0.2V \cdot 10^{\left[\frac{-58dB}{20}\right]} = 252\mu V_{pp}$$

# Signal to Noise Ratio (SNR)

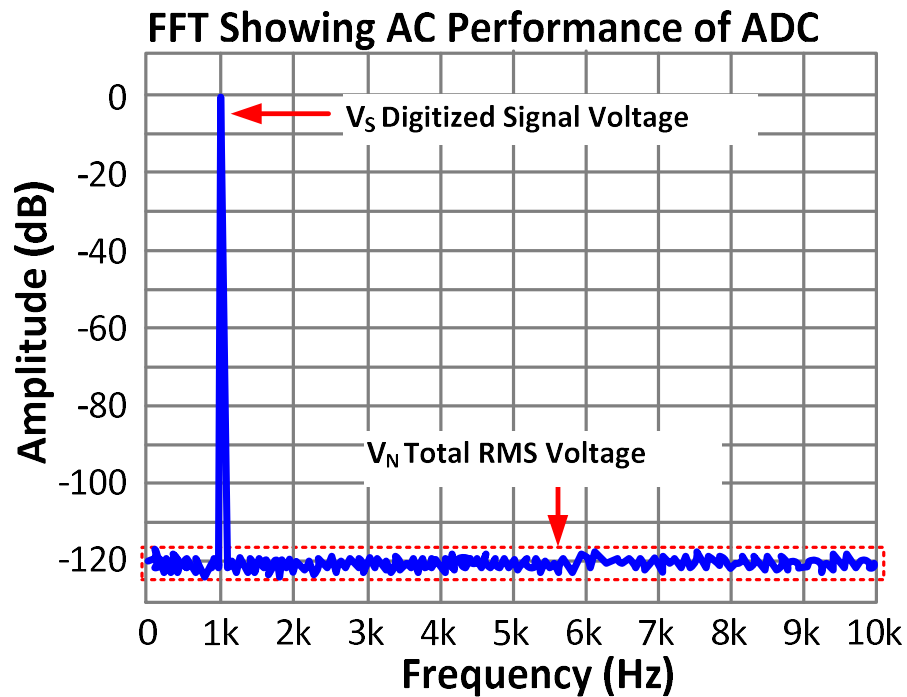

**Measured Ratio:**

$$SNR(V/V) = \frac{V_S}{V_N}$$

**Measured dB:**

$$SNR(dB) = 20 \cdot \log\left(\frac{V_S}{V_N}\right)$$

**Ideal ADC SNR:**

$$SNR(dB) = 6.02 \cdot N + 1.76$$

Where N is the number of bits

# Nonlinearity

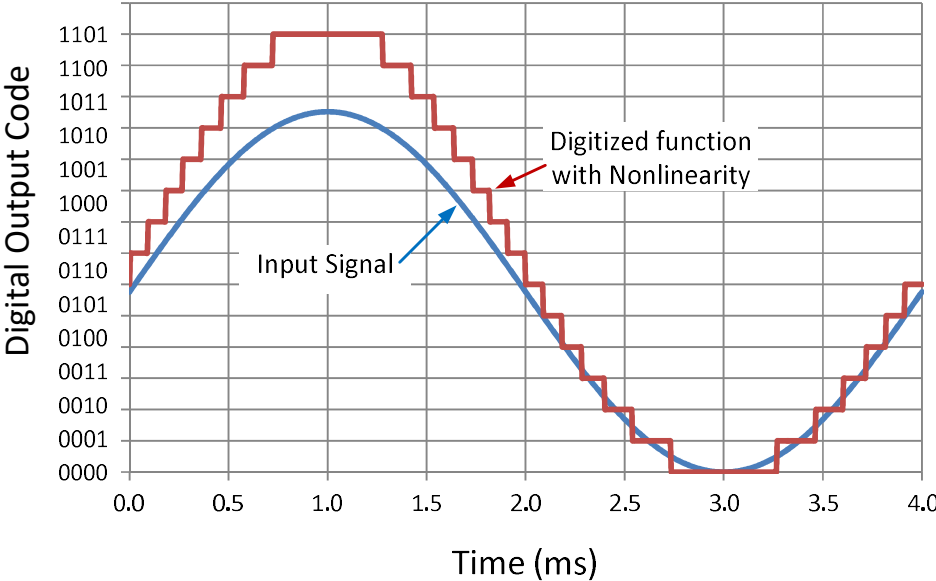
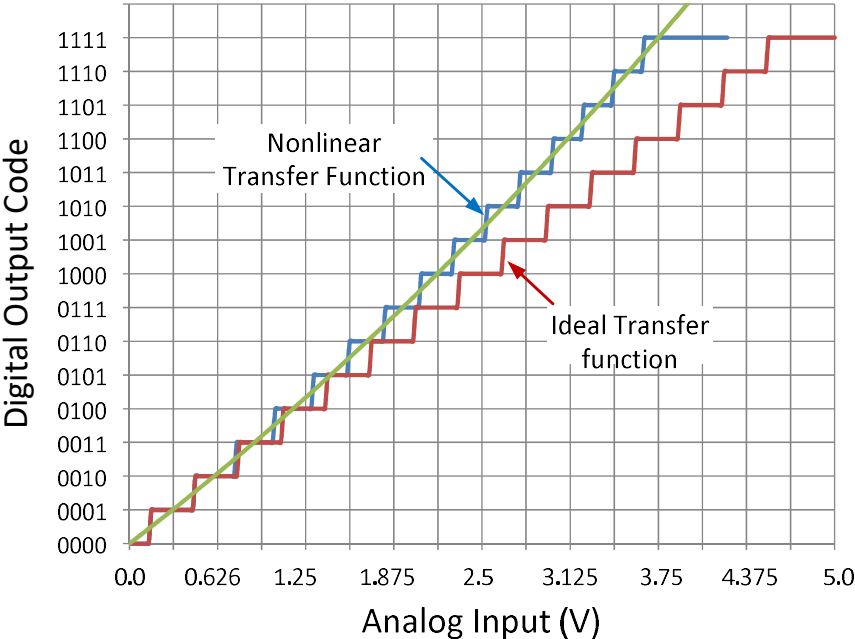

# Total Harmonic Distortion (THD)

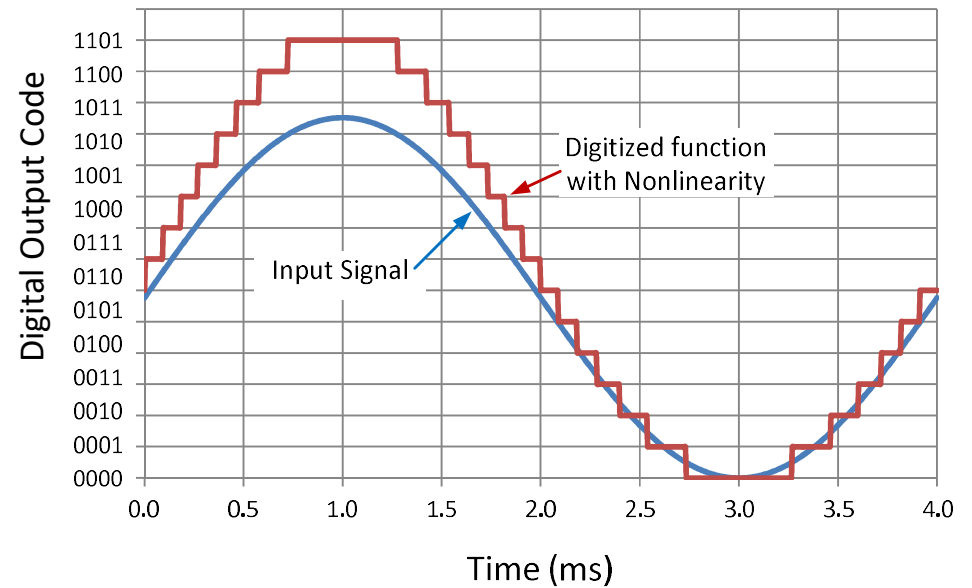
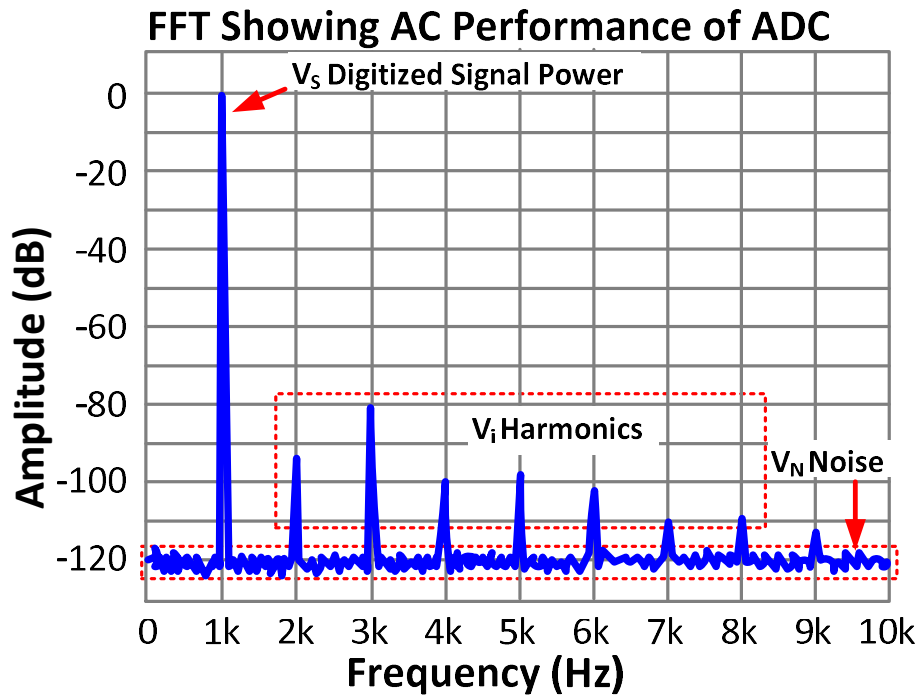



# Total Harmonic Distortion (THD), THD+N, SINAD

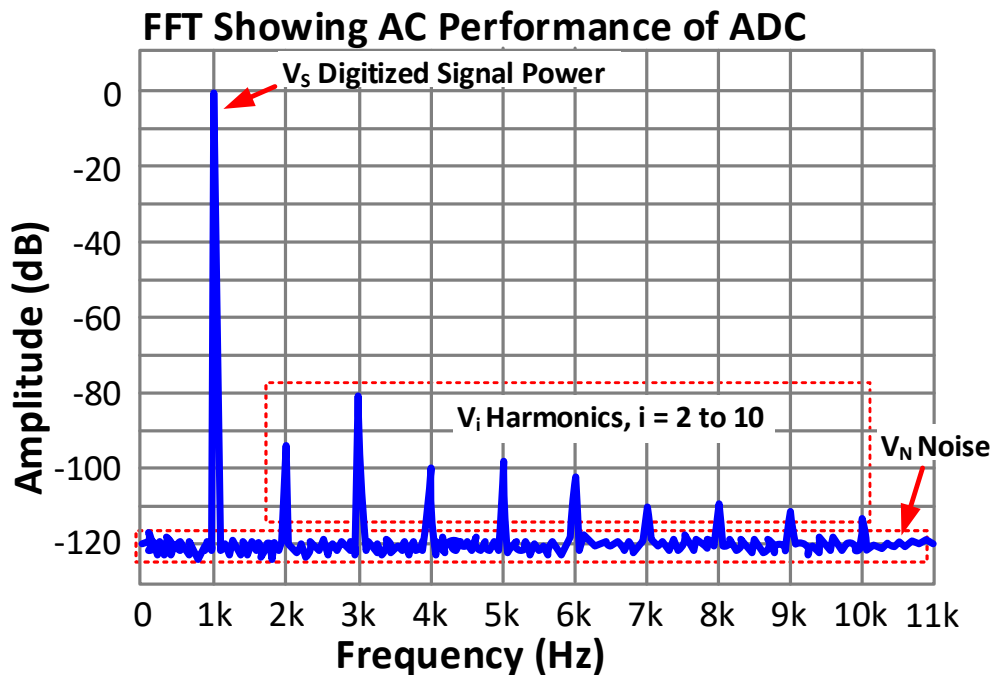

$$THD(\%) = \sqrt{\frac{\sum_{i=2}^{10} V_i^2}{V_S^2}} \cdot 100$$

$$THD(dB) = 20 \cdot \log \left( \sqrt{\frac{\sum_{i=2}^{10} V_i^2}{V_S^2}} \right)$$

$$(THD + N)(dB) = 20 \cdot \log \left( \sqrt{\frac{\sum_{i=2}^{10} V_i^2 + V_N^2}{V_S^2}} \right)$$

$$SINAD(dB) = 20 \cdot \log \left( \sqrt{\frac{V_S^2}{\sum_{i=2}^{10} V_i^2 + V_N^2}} \right)$$

**Thanks for your time!  
Please try the quiz.**

# AC & DC Specifications:

offset error, gain error, CMRR, PSRR, SNR, THD

TIPL 4002  
TI Precision Labs – ADCs

Created by Art Kay

Presented by Peggy Liska

Hello, and welcome to the TI Precision Lab introducing AC & DC specifications.

In this video we'll define offset error, gain error, common mode rejection ratio, and power supply rejection ratio. We will also give a brief introduction to the AC specifications of signal to noise ratio and total harmonic distortion.

# Offset & Gain Error

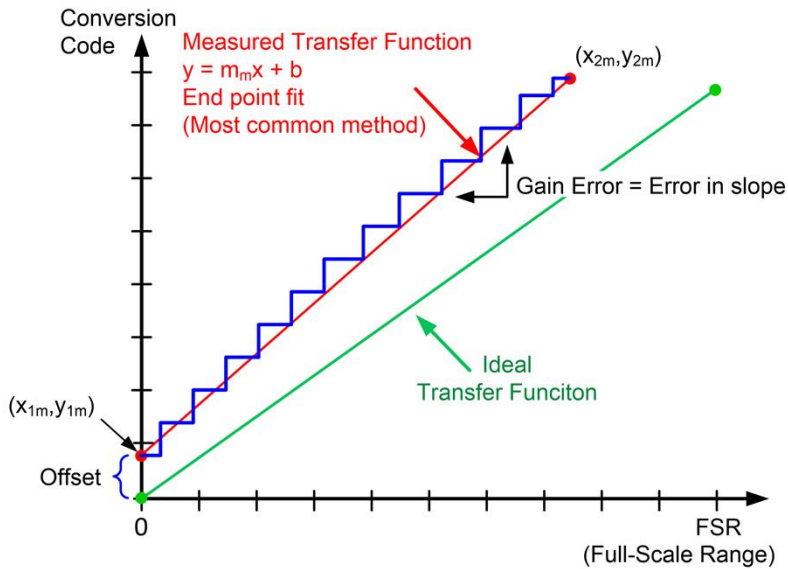

Offset and Gain Error based on End point fit:

Straight Line Fit  $y = m_m \cdot x + b$

Measured Transfer Function  $m_m = \frac{y_{2m} - y_{1m}}{x_{2m} - x_{1m}}$

Offset Error  $b = y - m_m \cdot x$

Gain Error  $E_G = \left( \frac{m_m - m_i}{m_i} \right) \cdot 100\%$   
 ( $m_i$  is the ideal transfer function)

Let's start with the basic calculation for offset and gain error. The key to understanding this is to know that the ADC transfer function is not perfectly linear, so a linear curve fit is applied to the function. For this calculation, the most commonly used type of curve fit is an end point linear fit. With this type of curve fit, the first and last points on the ADC transfer function define the straight line.

Recall that a straight line has the equation:  $y = mx + b$ . Also, the slope can be calculated by taking the change in  $y$  divided by the change in

x. Sometimes this is referred to as the “rise over run”. The offset is the y-axis intercept. That is, the offset is the value of the transfer function when  $x=0$ . This value can be calculated by rearranging the equation  $y=mx + b$  and solving for  $b$ . Where  $b$  is the offset. The gain error is the percentage difference between the ideal slope and the measured slope. The gain error and offset error are often referred to as “dc” errors as they can be measured with dc input signals applied. Now let’s see how offset error can be affected by changes in supply voltage or common mode voltage.

# Common Mode Rejection & Power Supply Rejection

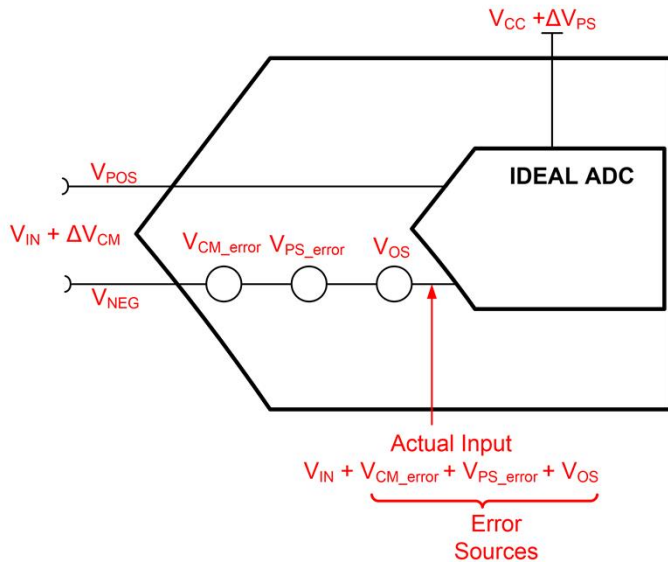

$$V_{CM} = \left( \frac{V_{POS} + V_{NEG}}{2} \right)$$

$$CMRR(dB) = -20 \cdot \log \left( \frac{\Delta V_{CM\_error}}{\Delta V_{CM}} \right)$$

$$\Delta V_{CM\_error} = \Delta V_{CM} \cdot 10^{\left[ \frac{-CMRR(dB)}{20} \right]}$$

$$PSRR(dB) = -20 \cdot \log \left( \frac{\Delta V_{PS\_error}}{\Delta V_{PS}} \right)$$

$$\Delta V_{PS\_error} = \Delta V_{PS} \cdot 10^{\left[ \frac{-PSRR(dB)}{20} \right]}$$

Here we introduce the concept of common mode rejection and power supply rejection. The common mode voltage is the average voltage applied to both inputs. As this input changes it will introduce an error source that can be modeled as an offset voltage source on the ADC input,  $V_{CM\_error}$ . The magnitude of this error source can be determined using the common mode rejection ratio, or CMRR, specification. CMRR is usually specified in decibels, and can be calculated by taking -20 times the log of the change in common mode error divided by the change in common mode voltage. This equation can be rearranged to solve for the change in common mode error based on the change in common mode voltage.

Power supply rejection, or PSRR, also generates an error source in series with the ADC input. Power supply rejection error is a function of the change in the power supply voltage. Variations or noise on the power supply will reflect back to the input as an error source. The equation for power supply rejection is the same form as the common mode rejection, but in this case it is based on power supply variations. Again this can be rearranged to solve for the change in power supply rejection error based on the change in supply voltage. We will take a closer look at CMRR and PSRR in the next few slides.

# Common Mode Rejection - CMRR

AVDD = 3V, DVDD = 3V, VREF = 5V, VCM = 2.5V, AND  $f_{\text{sample}} = 1\text{Msps}$  unless otherwise noted

PARAMETER	TEST CONDITION	MIN	TYP	MAX	UNIT
<b>SYSTEM PERFORMANCE</b>					
<b>CMRR</b>	Common-mode rejection ratio	90	100		dB

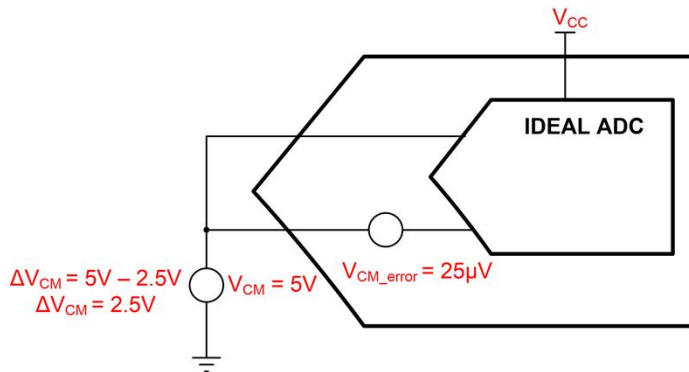

$$V_{CM} = \left( \frac{V_{POS} + V_{NEG}}{2} \right)$$

$$\Delta V_{CM\_error} = \Delta V_{CM} \cdot 10^{\left[ \frac{-CMRR(dB)}{20} \right]}$$

$$\Delta V_{CM\_error} = 2.5V \cdot 10^{\left[ \frac{-100dB}{20} \right]} = 25\mu V$$

This slide shows an example of an ADC's common mode rejection specification. A simple way to test common mode rejection is to connect the two inputs together and sweep the common mode voltage. Remember that common mode voltage is the average of the voltage on the two inputs, so when the inputs are tied together the input signal is the common mode voltage. In this example if we sweep the common mode voltage from 5V to 2.5V the change in common mode voltage is 2.5V. Substituting these numbers into the common mode rejection equation we can see that the common mode error is 25uV.



# Power Supply Rejection - PSRR

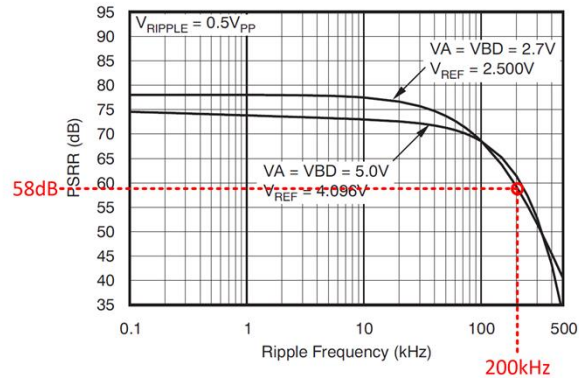
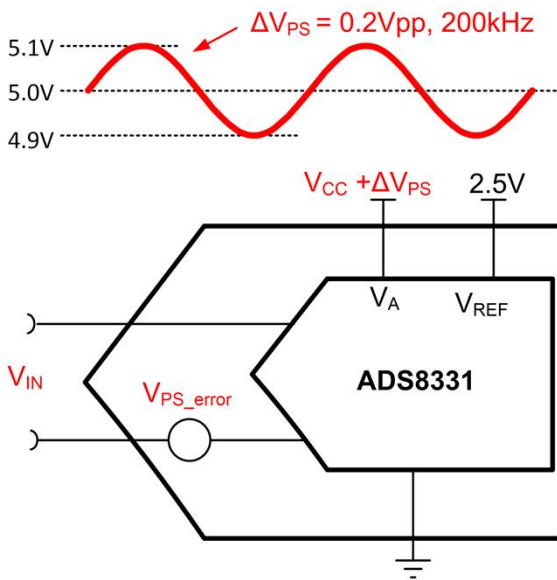

$$\Delta V_{PS\_error} = \Delta V_{PS} \cdot 10^{\left[\frac{-PSRR(dB)}{20}\right]}$$

$$\Delta V_{PS\_error} = 0.2V \cdot 10^{\left[\frac{-58dB}{20}\right]} = 252\mu V_{pp}$$

Power supply rejection looks at the error introduced by a change in the power supply voltage. This shift can be a dc change in supply voltage or it may be a noise signal. For this example let's consider a 0.2Vpp 200kHz noise signal on the supply. Normally, the specification listed in the data sheet table is the PSRR for DC changes in the power supply voltage. For the PSRR over frequency, a bode plot may be shown in the characteristic curve section. In this example we can find that the PSRR is 58dB at 200kHz. Using the PSRR equation introduced earlier, we can determine the error introduced by the power supply rejection. Plugging the 0.2Vpp and 58dB into the equation yields a noise of 252uVpp.

## Signal to Noise Ratio (SNR)

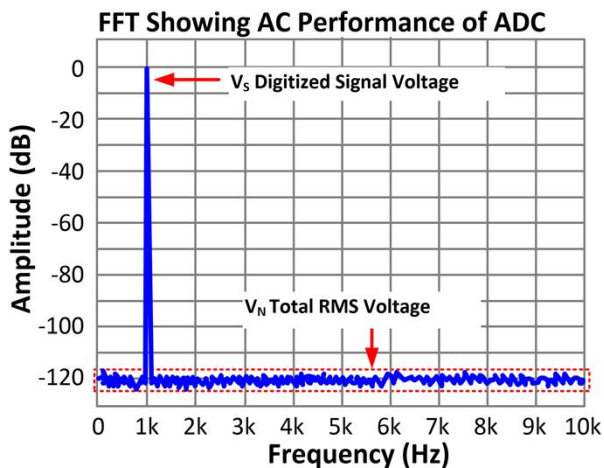

**Measured Ratio:**

$$SNR(V/V) = \frac{V_S}{V_N}$$

**Measured dB:**

$$SNR(dB) = 20 \cdot \log\left(\frac{V_S}{V_N}\right)$$

**Ideal ADC SNR:**

$$SNR(dB) = 6.02 \cdot N + 1.76$$

Where N is the number of bits

Let's move on to the next specification. This slide shows the general equation for a data converter's signal-to-noise ratio, or SNR. In general, the signal to noise ratio is a measurement of how clean or noise-free a signal is. A high SNR indicates that the signal is very large in comparison to the noise whereas a low SNR indicates that the noise is high relative to the signal. For this specification, both the signal and noise are measured in volts rms. So, you need to take 20 times the log of the ratio to convert it to decibels. The ideal SNR in decibels can be calculated by taking  $6.02 \cdot N + 1.76$ , where N is the number of bits of resolution of the ADC. A 10-bit converter, for example, would have  $6.02 \cdot 10 + 1.76$  or 61.96dB. This relationship was derived by integrating the

quantization noise and applying the signal to noise relationship. This relationship is true for an ideal converter where the only error source considered is quantization noise. No practical data converter will have a better signal to noise than what is given by this equation because practical converters have other noise sources.

# Nonlinearity

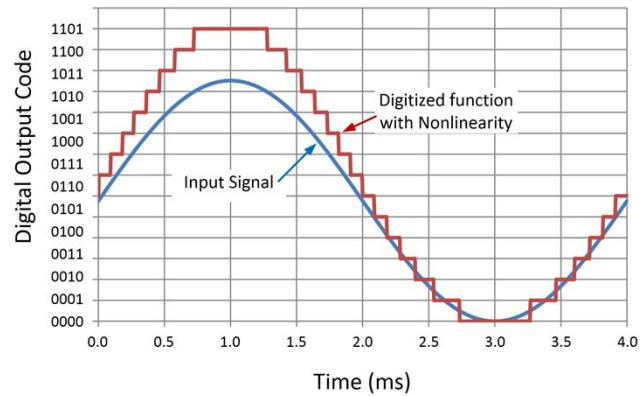
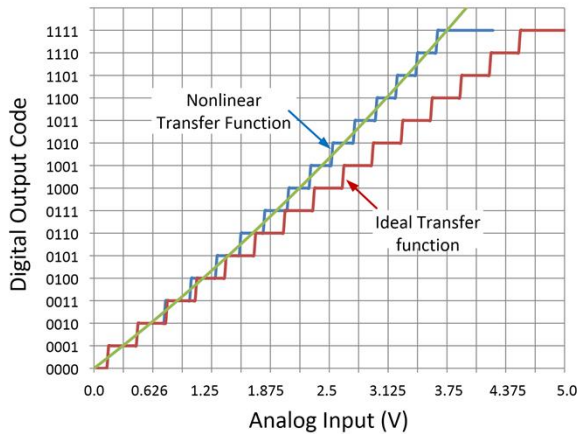

Another common ac specification is Total Harmonic Distortion, or THD. In order to understand THD, it is important to understand nonlinearity. Nonlinearity is a measurement of how much a transfer function deviates from its ideal straight line. The transfer function shown on the left-hand side of the slide shows an ideal linear transfer function and a nonlinear transfer function. The ideal transfer function follows a straight line in the form  $y=mx+b$ , whereas the nonlinear transfer function will have higher order terms causing deviations from the line. The nonlinear example shown is exaggerated to make the nonlinearity easy to see. Notice how the nonlinear function tracks well for low input voltage levels and deviates as the input increases. In short, the gain for

higher input signals is larger than it should be. This has the effect of stretching out the top half cycle of the sine wave. This stretching of the top half cycle is called distortion and will create harmonics in the frequency spectrum.

# Total Harmonic Distortion (THD)

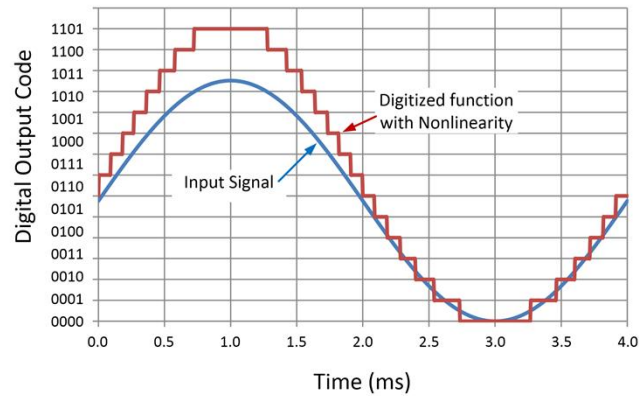
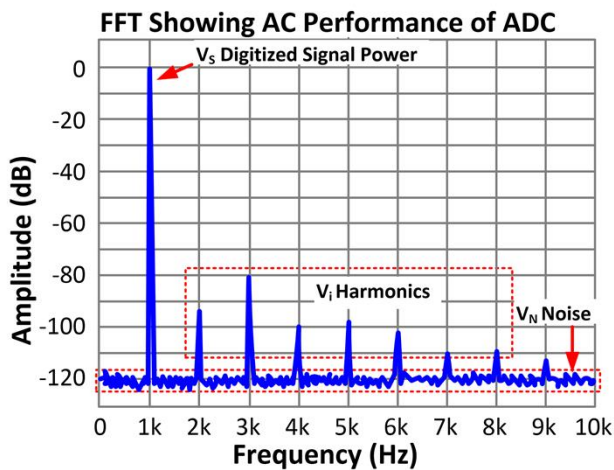

This slide shows the frequency spectrum for the digitized sine wave at the right. The harmonics are a result of the distortion on the top half cycle of the waveform.

Harmonic distortion will always occur at integer multiples of the fundamental frequency. In this case the fundamental is at 1kHz and there are harmonics at 2kHz, 3kHz, 4kHz and so on. Sometimes it is useful to differentiate between even and odd harmonics, as different circuit nonidealities may generate one type of harmonic. Even harmonics are even multiples of the fundamental frequency and odd harmonics are odd multiples of the fundamental. In this example, 2kHz and 4kHz are even harmonics whereas 3kHz and 5kHz are odd harmonics. If the digitized signal perfectly tracked the

input signal, there would not be any harmonics.

## Total Harmonic Distortion (THD), THD+N, SINAD

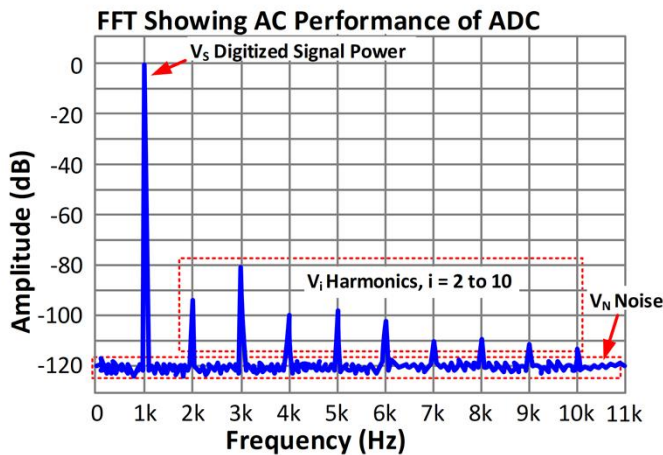

$$THD(\%) = \sqrt{\frac{\sum_{i=2}^{10} V_i^2}{V_s^2}} \cdot 100$$

$$THD(dB) = 20 \cdot \log \left( \sqrt{\frac{\sum_{i=2}^{10} V_i^2}{V_s^2}} \right)$$

$$(THD + N)(dB) = 20 \cdot \log \left( \sqrt{\frac{\sum_{i=2}^{10} V_i^2 + V_N^2}{V_s^2}} \right)$$

$$SINAD(dB) = 20 \cdot \log \left( \sqrt{\frac{V_s^2}{\sum_{i=2}^{10} V_i^2 + V_N^2}} \right)$$

The THD calculation is given here as a percentage as well as in decibels. The IEEE standard for ADC testing specifies that the second through tenth harmonics should be used in the THD calculations. THD is the square root of sum of the harmonic voltages squared divided by the rms signal voltage squared. This quantity is multiplied by 100 to convert to percentage or 20 times the log is taken to convert to decibels. THD+N is similar to THD except that it includes the total rms noise in the calculation. SINAD is short for signal to noise and distortion. Mathematically, SINAD is simply the reciprocal of the THD+N calculation. In decibels, taking the reciprocal will just change the sign of the number. Note that SINAD or THD+N will always be worse than either the THD or SNR because SINAD is really



a combination of the two error sources.

**Thanks for your time!  
Please try the quiz.**

That concludes this video – thank you for watching!  
Please try the quiz to check your understanding of this  
video's content.

# Quiz: AC & DC Specifications

TIPL 4002

TI Precision Labs – ADCs

Created by Art Kay

# Quiz: AC & DC Specifications

1. Gain error is a measurement of \_\_\_\_\_.
  - a. The measured code width compared to the ideal code width.
  - b. How the measured slope compares to the ideal slope.
  - c. The ADC output with an input of zero volts.
  
2. Offset error is a measurement of \_\_\_\_\_.
  - a. The measured code width compared to the ideal code width.
  - b. How the measured slope compares to the ideal slope.
  - c. The ADC output with an input of zero volts.

# Quiz: AC & DC Specifications

3. Power supply rejection can be used to \_\_\_\_\_.
  - a. See how noise applied to the input impacts performance.
  - b. See how noise on the power supply impacts performance.
  - c. Check how the power supply voltage impacts self heating.
  - d. Check how the power supply voltage impacts ac performance.
  
4. Slope and offset of a converter can be computed using the following equations.
  - a.  $m = (y_2 - y_1)/(x_2 - x_1)$ ,  $b = y_1 - m \cdot x_1$
  - b.  $m = (y_2 + y_1)/(x_2 + x_1)$ ,  $b = y_1 - m \cdot x_1$
  - c.  $m = (y_2 - y_1)/(x_2 - x_1)$ ,  $b = y_1 + m \cdot x_1$
  - d.  $m = (y_2 - y_1)/(x_2 - x_1)$ ,  $b = -y_1 - m \cdot x_1$

# Quiz: AC & DC Specifications

5. (T/F) SNR is related to system nonlinearity.
  - a. True.
  - b. False.
  
6. (T/F) THD is related to system nonlinearity.
  - a. True.
  - b. False.
  
7. (T/F) THD + N combines the error sources from SNR and THD.
  - a. True.
  - b. False.



# Solutions

# Solutions Quiz: AC & DC Specifications

1. Gain error is a measurement of \_\_\_\_\_.
  - a. The measured code width compared to the ideal code width.
  - b. How the measured slope compares to the ideal slope.
  - c. The ADC output with an input of zero volts.
  
2. Offset error is a measurement of \_\_\_\_\_.
  - a. The measured code width compared to the ideal code width.
  - b. How the measured slope compares to the ideal slope.
  - c. The ADC output with an input of zero volts.



# Solutions Quiz: AC & DC Specifications

3. Power supply rejection can be used to \_\_\_\_.
- a. See how noise applied to the input impacts performance.
  - b. See how noise on the power supply impacts performance.
  - c. Check how the power supply voltage impacts self heating.
  - d. Check how the power supply voltage impacts ac performance.
4. Slope and offset of a converter can be computed using the following equations.
- a.  $m = (y_2 - y_1)/(x_2 - x_1)$ ,  $b = y_1 - m \cdot x_1$
  - b.  $m = (y_2 + y_1)/(x_2 + x_1)$ ,  $b = y_1 - m \cdot x_1$
  - c.  $m = (y_2 - y_1)/(x_2 - x_1)$ ,  $b = y_1 + m \cdot x_1$
  - d.  $m = (y_2 - y_1)/(x_2 - x_1)$ ,  $b = -y_1 - m \cdot x_1$

# Solutions Quiz: AC & DC Specifications

5. (T/F) SNR is related to system nonlinearity.

a. True.

**b. False.**

6. (T/F) THD is related to system nonlinearity.

**a. True.**

b. False.

7. (T/F) THD + N includes the combines the error sources from SNR and THD.

**a. True.**

b. False.