



Slew Rate – 1
TIPL 1221
TI Precision Labs – Op Amps

Presented by Ian Williams
Prepared by Art Kay and Ian Williams

 TEXAS INSTRUMENTS

Hello, and welcome to the TI Precision Lab discussing slew rate, part 1. In this video we'll go over the theory behind slew rate and compare the slew rate and current consumption of different TI amplifiers.

Slew Rate Defined

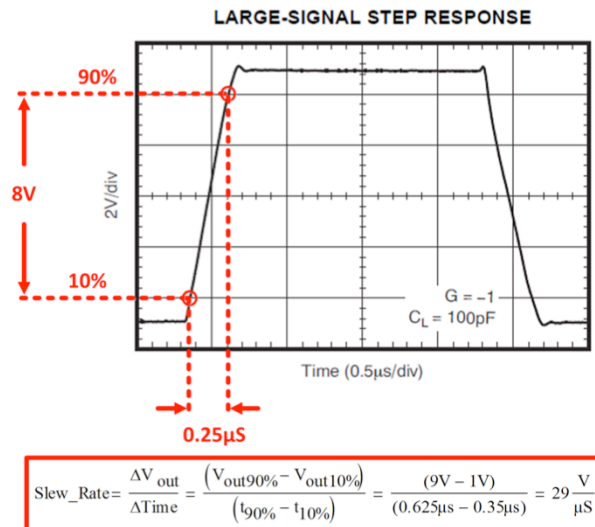

2

 TEXAS INSTRUMENTS

Slew rate is defined as the maximum rate of change of an op amp's output voltage and is given units of volts per microsecond. Slew rate is measured by applying a large signal step, such as 1V, to the input of the op amp, and measuring the rate of change from 10% to 90% of the output signal's amplitude.

The data sheet large-signal step response is an indication of the amplifiers slew rate. In this example, we calculate the slew rate to be about 29V/us. Again, the slew rate definition only considers the rate of change of the signal from 10% to 90%, which in this case is 1V to 9V.

Slew rate is a different specification than small-signal bandwidth, which considers differential input signals of $\pm 100\text{mV}$ or less.

Capacitor Physics Review

- With constant current applied, the voltage across a capacitor changes linearly over time

$$i = C \cdot \frac{dv}{dt}$$

$$v(t) = m \cdot t$$

where

$v(t)$ -- voltage as a function of time

m -- slope of straight line function

t -- time

$$C \cdot \frac{d}{dt}(m \cdot t) = m$$

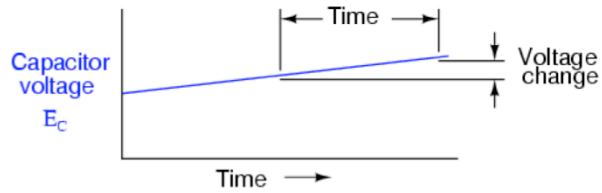

Potentiometer wiper moving slowly "up"

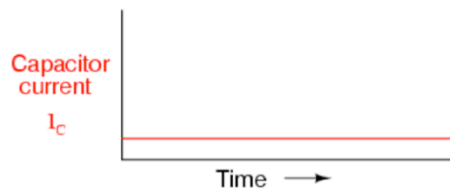

 TEXAS INSTRUMENTS

Before we get into an in-depth slew rate discussion, let's first review some basics.

The equation that defines how a capacitor works states that the current flow through a capacitor is equal to the capacitance times the derivative of voltage with respect to time. This behavior can also be interpreted to mean that if you have a constant current, then the voltage across the capacitor will rise linearly over time.

Slew Limit

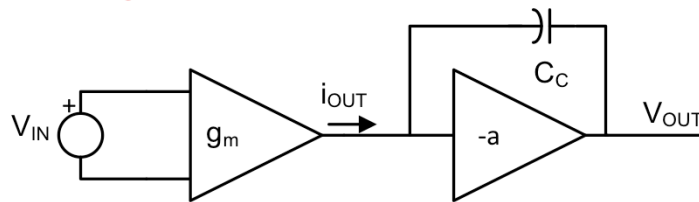

- For slow moving or small signals $i_{OUT} < i_{OUT(max)}$
- For large, rapid moving signals $i_{OUT} = i_{OUT(max)}$
 - The output is slew rate limited
 - This is the fastest rate the output can change
 - The input is no longer a virtual short
 - Large input differential voltages are possible
 - i_{OUT} is constant, so V_{OUT} increases linearly across capacitor C_C

4

TEXAS INSTRUMENTS

This is important with respect to slew rate of an amplifier. An amplifier has an internal g_M , or transconductance, stage which takes the input differential voltage and converts it to an output current, I_{OUT} . I_{OUT} flows into the next stage where it is used to charge C_C , which is called the Miller capacitance. If I_{OUT} is a constant, then the voltage across C_C will rise linearly with time, just like we discussed on the previous slide.

For slow-moving signals, I_{OUT} is less than some maximum value I_{OUT_MAX} . This means that I_{OUT} is able to change according to the differential input voltage without being limited. But for rapidly moving, large signals, I_{OUT} reaches its maximum and becomes limited to some constant value. In this case the input to the amplifier will no longer be a virtual short, and therefore a differential voltage will develop across the input pins. Since I_{OUT} is constant, V_{OUT} across the Miller capacitor C_C increases linearly over time. This is when the output of the amplifier is considered to be slew rate-limited, which is fastest that the output voltage can change.

Slew Rate – Inside the Amplifier

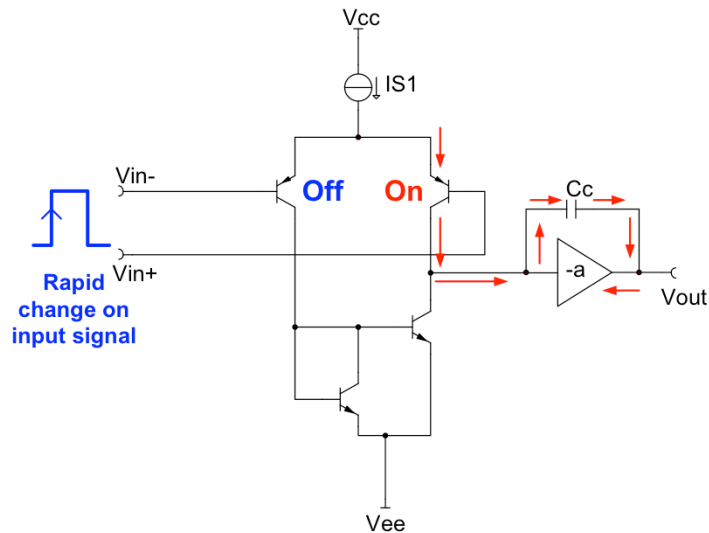

5

TEXAS INSTRUMENTS

Here is a transistor-level view of what's happening inside the amplifier. When we apply a step input to the amplifier, which is an extremely fast-moving signal, one transistor in the g_M stage will be turned off and the other will be turned fully on. The current flowing through the transistor which is ON, is the I_{OUT_MAX} mentioned in the previous slide. As previously discussed, I_{OUT_MAX} flows into the Miller capacitance C_C , causing the output voltage to ramp linearly over time.

Slew Rate of Different Amplifiers

Op amp	Slew Rate (typ)	I _Q (typ)
OPA369	0.005 V/μs	0.86 μA
OPA333	0.16 V/μs	17 μA
OPA277	0.8 V/μs	790 μA
OPA129	2.5 V/μs	1.2 mA
OPA350	22 V/μs	5.2 mA
OPA211	27 V/μs	3.6 mA
OPA827	28 V/μs	4.8 mA
OPA835	110 V/μs	250 μA
OPA847	850 V/μs	18.1 mA

6



Here we compare the typical slew rate and quiescent current, or I_Q, for different amplifiers.

On one end of the spectrum, we have the OPA369 which is a very low I_Q and low slew rate device. For 0.8μA of current we can achieve around 5mV/μs of slew. Compare that to the OPA847, which consumes 18.1mA of I_Q but can slew at 850V/μs. This shows us that amplifiers with higher slew rate, and therefore higher bandwidth, tend to have higher current consumption.

Simulate Slew Rate – OPA2188

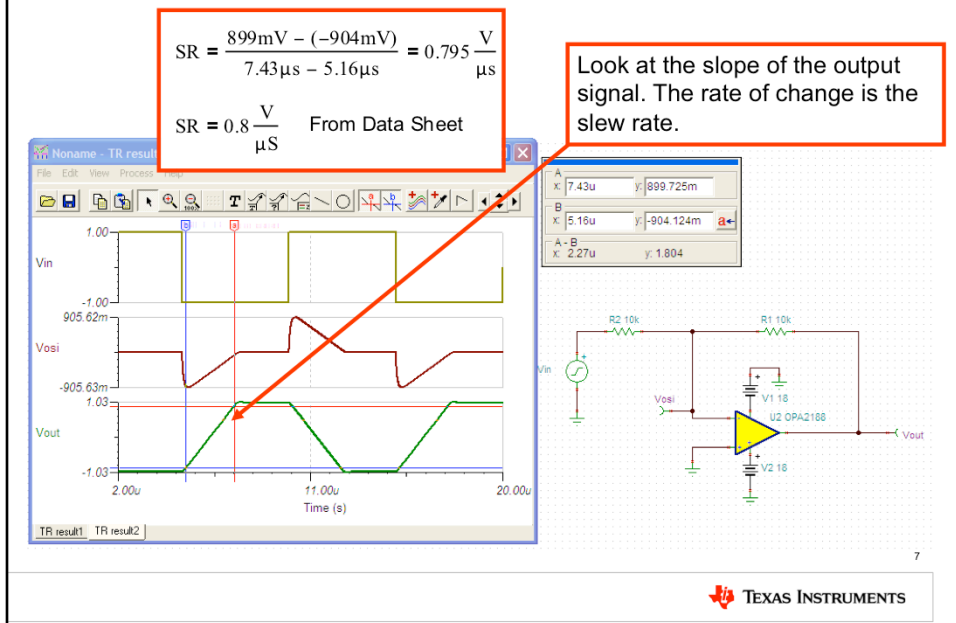

We can easily simulate slew rate using TINA-TI. Simply apply a step function to the input of the amplifier, which in this case is a $\pm 1\text{V}$ square wave. You can see that when this input step is applied, the input offset voltage changes from 0V - which indicates a virtual short - to some other voltage, around 900mV in this case. Most importantly, the output voltage becomes slew rate-limited, shown as a constant ramp in voltage over time until finally reaching its true value. You can observe the input offset voltage moving linearly back to 0V as well.

Calculating the slew rate from this plot gives a result of $0.795\text{V}/\mu\text{s}$. The data sheet for this device, the OPA2188, lists the slew rate as $0.8\text{V}/\mu\text{s}$, indicating that the model accurately simulates the slew rate of the amplifier.

Simulate Slew Rate – OPA2188

The input no longer is a virtual short. The output changes can not keep up with the input.

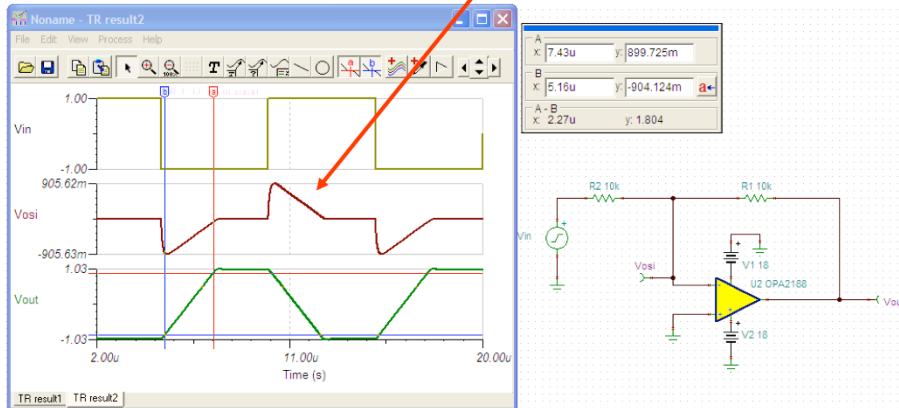

This slide emphasizes that fact that we no longer have a virtual short whenever a step function is applied to the input of the amplifier. The output moves slower than the input signal, and so we have some finite voltage across the input pins. As the output ramps linearly to its final value, the input gets closer and closer to a virtual short again, and once it does the amplifier returns to its closed-loop configuration.

Slew Rate Over Temperature

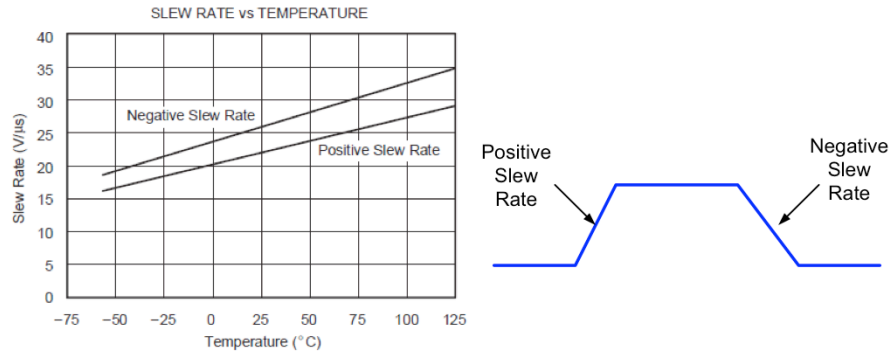

9

An amplifier's data sheet will provide a plot showing slew rate versus temperature, often for both positive and negative slew rates. Positive slew rate occurs when a signal is rising, and negative slew rate occurs when a signal is falling. Typically the slew rate of an amplifier will increase with increasing temperature.

Slew Boost

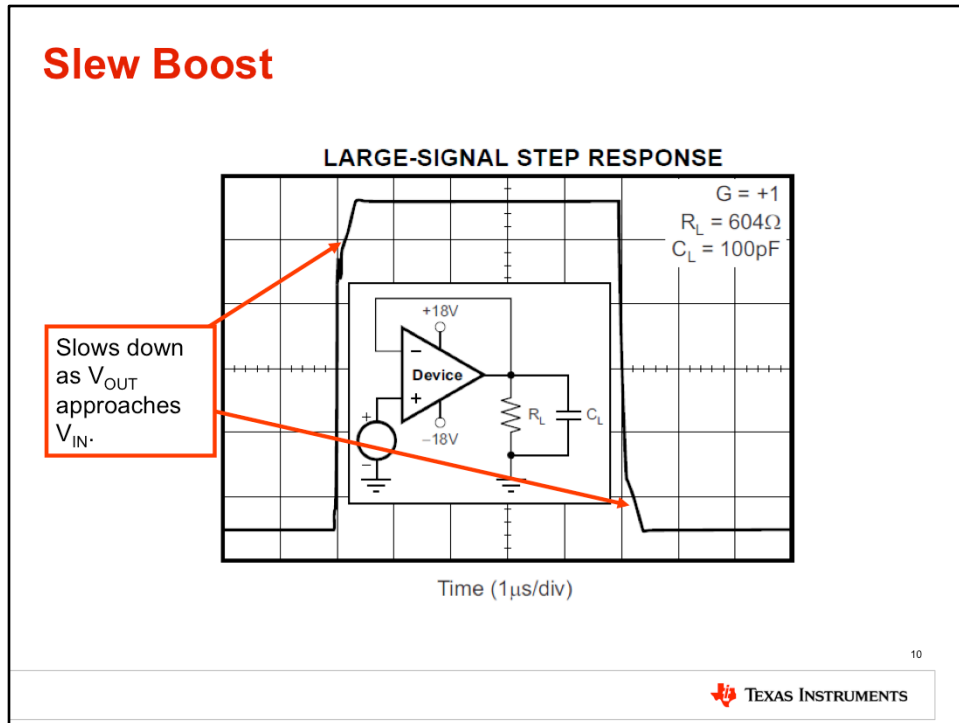

Some amplifiers include a “slew boost” circuit which allows for faster slew rates. An example of an amplifier with slew boost is shown in this large-signal step response plot. What happens is that the device has two different slew rates – an initial rate which is very fast, and a second, slower rate as the output settles to its final value. You may ask yourself, “why doesn’t the amplifier just have one slew rate which is always fast?” The reason is that with one, extremely fast slew rate, the output would have a large overshoot. When that overshoot occurred, the amplifier would try to compensate for this and the negative slew would kick in, resulting in a large negative overshoot. This behavior would continue, resulting in oscillation.

Current to Miller Capacitance – I_{CC}

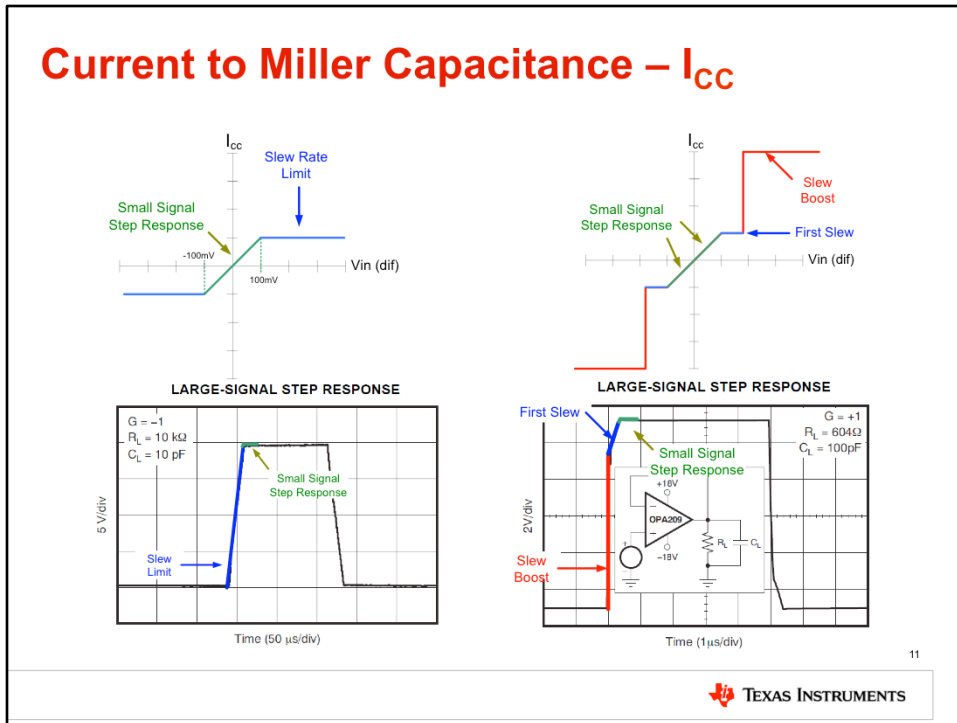

So how does this slew boost look compared to a standard amplifier? On the left hand side is the response of a standard amplifier. The green region shows the small-signal response (or differential input voltage greater than ± 100 mV), where the amplifier can linearly change the current flowing into the Miller capacitance. The blue region shows the large-signal response (or differential input voltage greater than ± 100 mV), where the amplifier reaches its slew rate limit and the current flow into the Miller capacitance is held constant..

We have a similar situation for an amplifier with slew boost. There is still a small-signal response shown by the green region, but once the differential input voltage exceeds a certain value we reach the slew rate limit, indicated by the blue region, and eventually the slew boost, indicated by the red region. Therefore, when a large step function is applied to the input of the amplifier, the device will initially see a large differential input voltage and will be in Slew boost mode, allowing a large output current into the Miller capacitance and therefore a quickly-ramping output voltage. As the differential input voltage decreases the amplifier will move to its standard slew rate, and finally to its small-signal response once the input voltage becomes small enough. At this point the output will settle and the inputs of the amplifier will once again be a virtual short.

Full Power Bandwidth

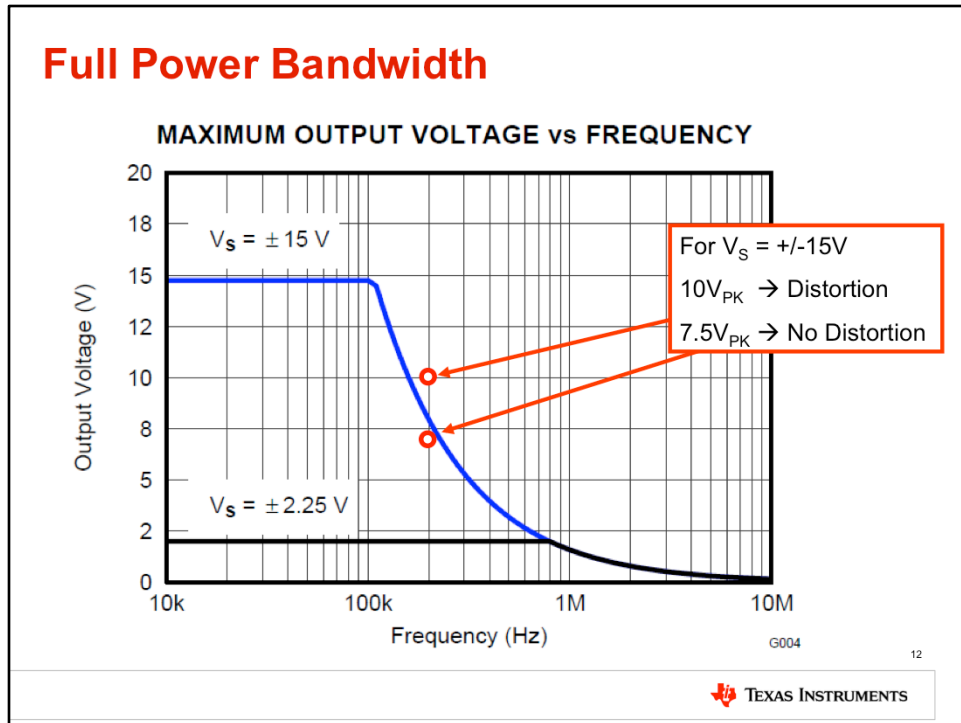

So far we have considered square waves when looking at slew rate. However, slew rate can limit (or distort) any signal amplified by an op-amp. This characteristic of the op-amp is called the full power bandwidth, or maximum output voltage vs. frequency.

The graph above shows the maximum output sinusoidal waveform that can be applied without slew-induced distortion. This example considers a 200kHz signal at both 7.5Vpk and 10Vpk. At 7.5Vpk, the output signal is under the curve and therefore will not be distorted by slew rate limitations. At 10Vpk, the output signal is above the curve and will be distorted by slew rate limits.

No Slew-Induced Distortion ($7.5V_{PK}$ Output)

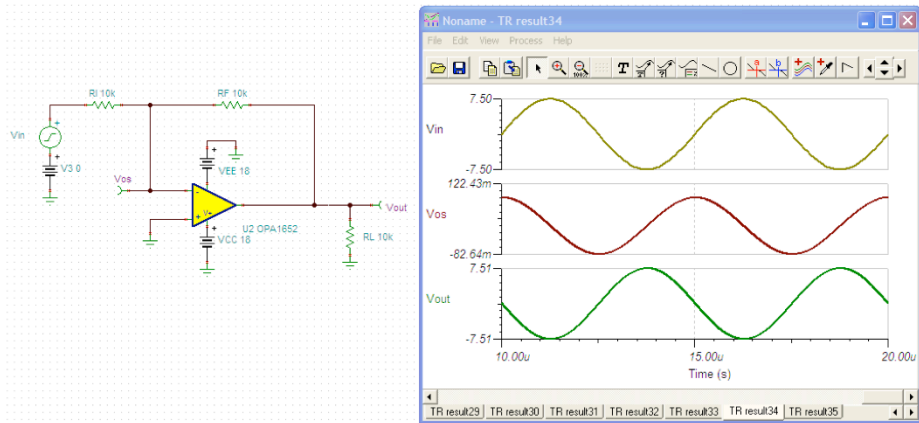

13



This simulation verifies that the 200kHz signal with 7.5V peak amplitude will not be distorted. The output looks like an accurately amplified version of the input. As a side note, the "offset" voltage looks like a sinusoidal wave also. The offset is really just the output voltage divided by divided by AOL, the op-amp's open-loop bandwidth, at the frequency of interest (200kHz in this example).

Slew-Induced Distortion ($10V_{PK}$ Output)

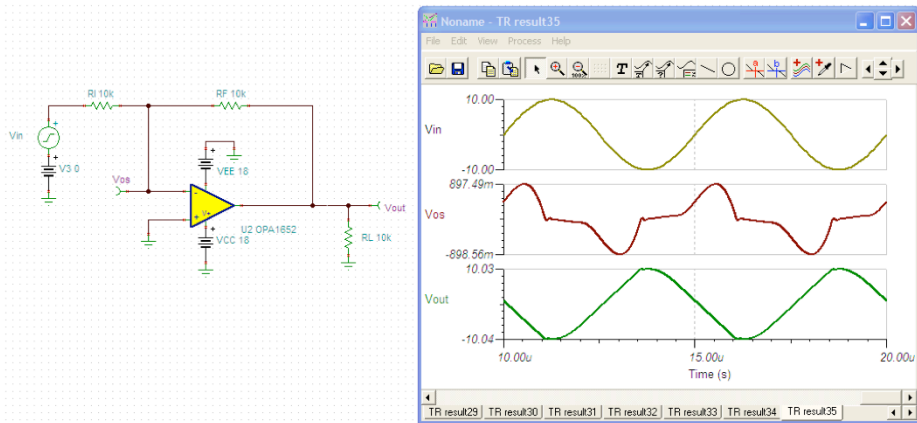

14

TEXAS INSTRUMENTS

This example verifies that the signal with 10V peak will be distorted. The output looks more like a triangle wave than a sinusoidal wave due to the slew-induced distortion. The input offset is also clearly distorted, and is no longer equal to the output voltage divided by AOL.

Maximum Output vs. Frequency – Derived

$$V_{out} = V_p \cdot \sin(\omega t)$$

$$\frac{d}{dt}(V_{out}) = \omega V_p \cdot \cos(\omega t) \quad \text{Rate of change.}$$

Maximum happens at $\cos(\omega t) = 1$

$$\text{Max_Rate_of_Change} = \omega V_p$$

$$\text{SR} = 2\pi \cdot V_p \cdot f$$

$$V_p = \frac{\text{SR}}{2\pi \cdot f}$$

for OPA1652 example at 200kHz

$$\text{SR} := 10 \frac{\text{V}}{\mu\text{s}} \quad f := 200\text{kHz}$$

$$V_p := \frac{\text{SR}}{2\pi \cdot f} = 7.958\text{V}$$

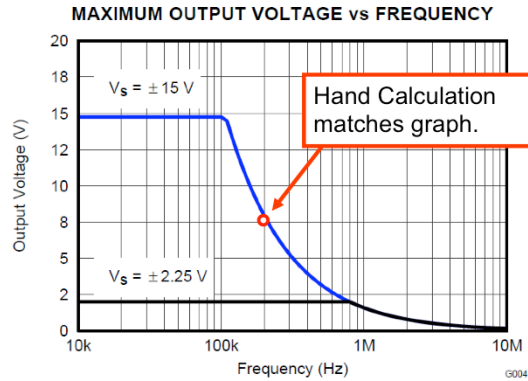

15

TEXAS INSTRUMENTS

This slide illustrates that the maximum output vs. frequency curve can be derived with calculus. You can go through the math on your own, but the key point is that the final equation, $V_{pk} = \text{SR} / (2 \pi f)$ can be used if this curve is not available. The example shown in red confirms that the equation yields the same result as the curve.

**Thanks for your time!
Please try the quiz.**

16



That concludes this video – thank you for watching! Please try the quiz to check your understanding of this video’s content.

Slew Rate 1

Multiple Choice Quiz

TI Precision Labs – Op Amps



Quiz: Slew Rate 1

1. **When a constant current is applied to a capacitor, the voltage on the capacitor will ____.**
 - a. Increase exponentially.
 - b. Increase linearly.
 - c. Remain constant.
 - d. Oscillate.

2. **Slew rate is defined as ____.**
 - a. The maximum rate of change of an input signal.
 - b. The maximum frequency that can be applied before attenuation.
 - c. The maximum rate of change of the output voltage.
 - d. The rate of current consumption of the amplifier.

3. **Different model amplifiers have different slew rates. Surveying many different models, you will see slew rate vary from ____.**
 - a. $0.1\text{V}/\mu\text{s}$ to $1000\text{V}/\mu\text{s}$
 - b. $10\text{V}/\mu\text{s}$ to $100\text{V}/\mu\text{s}$
 - c. $1\text{V}/\text{ns}$ to $100\text{V}/\text{ns}$
 - d. $0.1\text{V}/\text{ms}$ to $1000\text{V}/\text{ms}$

Quiz: Slew Rate 1

4. What differential input would you expect when an op amp is in slew rate limit?

- a. The differential input is the input offset and would range from μV to mV .
- b. The differential input can be volts during slew limit.
- c. The differential input is not affected when an amplifier is in slew limit.

5. Most amplifier data sheets contain a graph called the “large signal step response” curve. What does this curve illustrate?

- a. The maximum output swing range for an amplifier.
- b. A large rapid change in load resistance.
- c. The output in slew limit with the input about 80% of the supply range.
- d. The output with a 100mV step applied to the input.

Slew Rate 1

Multiple Choice Quiz: Solutions

TI Precision Labs – Op Amps

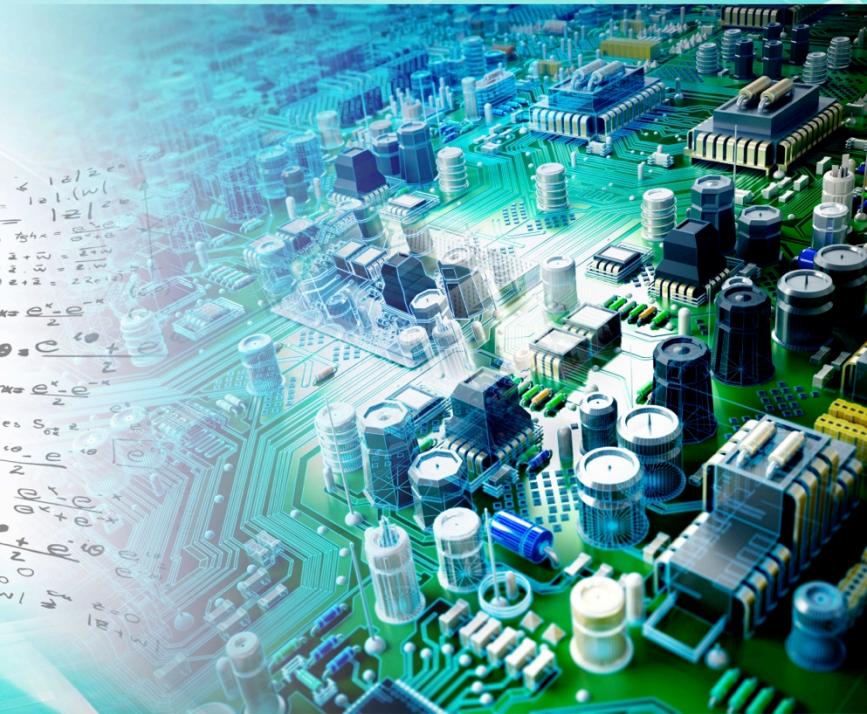

Quiz: Slew Rate 1

1. When a constant current is applied to a capacitor, the voltage on the capacitor will ____.

- a. Increase exponentially.
- b. Increase linearly.
- c. Remain constant.
- d. Oscillate.

2. Slew rate is defined as ____.

- a. The maximum rate of change of an input signal.
- b. The maximum frequency that can be applied before attenuation.
- c. The maximum rate of change of the output voltage.
- d. The rate of current consumption of the amplifier.

3. Different model amplifiers have different slew rates. Surveying many different models, you will see slew rate vary from _____.

- a. 0.1V/ μ s to 1000V/us
- b. 10V/ μ s to 100V/us
- c. 1V/ns to 100V/ns
- d. 0.1V/ms to 1000V/ms

Quiz: Slew Rate 1

4. What differential input would you expect when an op amp is in slew rate limit?

- a. The differential input is the input offset and would range from μV to mV .
- b. The differential input can be volts during slew limit.
- c. The differential input is not affected when an amplifier is in slew limit.

5. Most amplifier data sheets contain a graph called the “large signal step response” curve. What does this curve illustrate?

- a. The maximum output swing range for an amplifier.
- b. A large rapid change in load resistance.
- c. The output in slew limit with the input about 80% of the supply range.
- d. The output with a 100mV step applied to the input.

Slew Rate 1

Exercises

TI Precision Labs – Op Amps



1. Draw the output waveform for the circuit below and the excerpt from the data sheet. Confirm this result with simulation.

FREQUENCY RESPONSE					
GBW	Gain-bandwidth product		2	MHz	
SR	Slew rate	$G = +1$	0.8	V/ μ s	
t_s	Settling time	0.1%	$V_S = \pm 18$ V, $G = 1$, 10-V step	20	μ s
		0.01%	$V_S = \pm 18$ V, $G = 1$, 10-V step	27	μ s
t_{OR}	Overload recovery time	$V_{IN} \times G = V_S$	1	μ s	
THD+N	Total harmonic distortion + noise	1 kHz, $G = 1$, $V_{OUT} = 1$ Vrms	0.0001%		

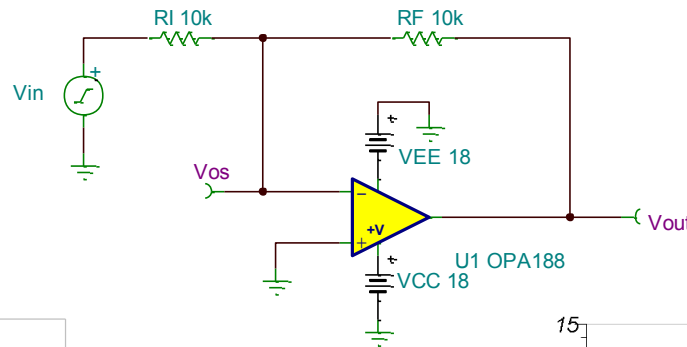

Draw Output Here

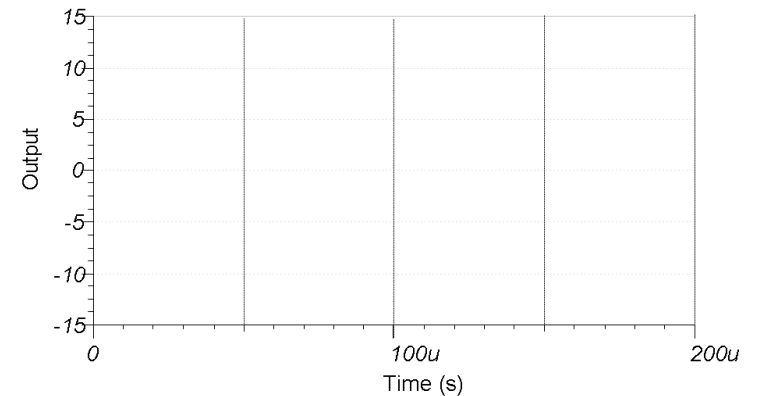
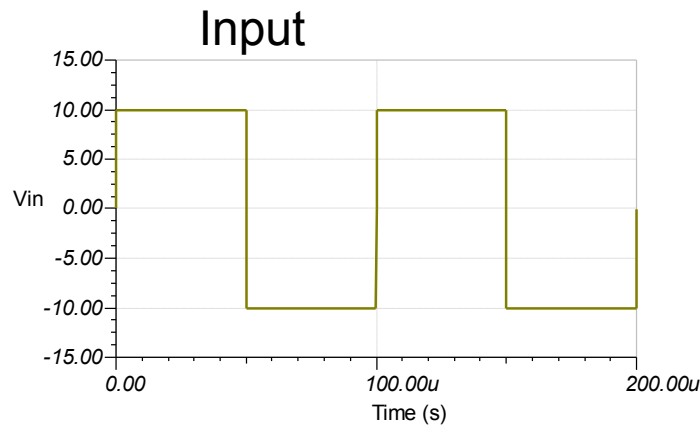

2. Why does the output waveform below have two different slopes?

LARGE-SIGNAL STEP RESPONSE

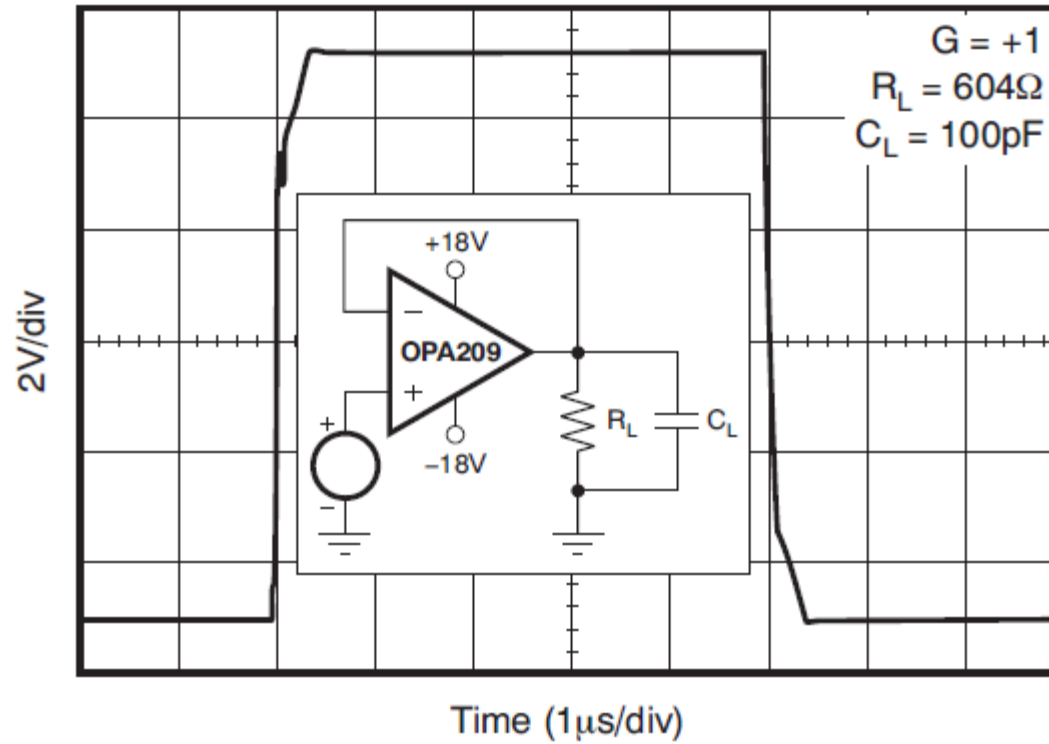

3. Will the circuit below have an issue with slew induced distortion? What is the maximum 400kHz input signal that can be applied before significant slew induced distortion? What is the bandwidth limit?

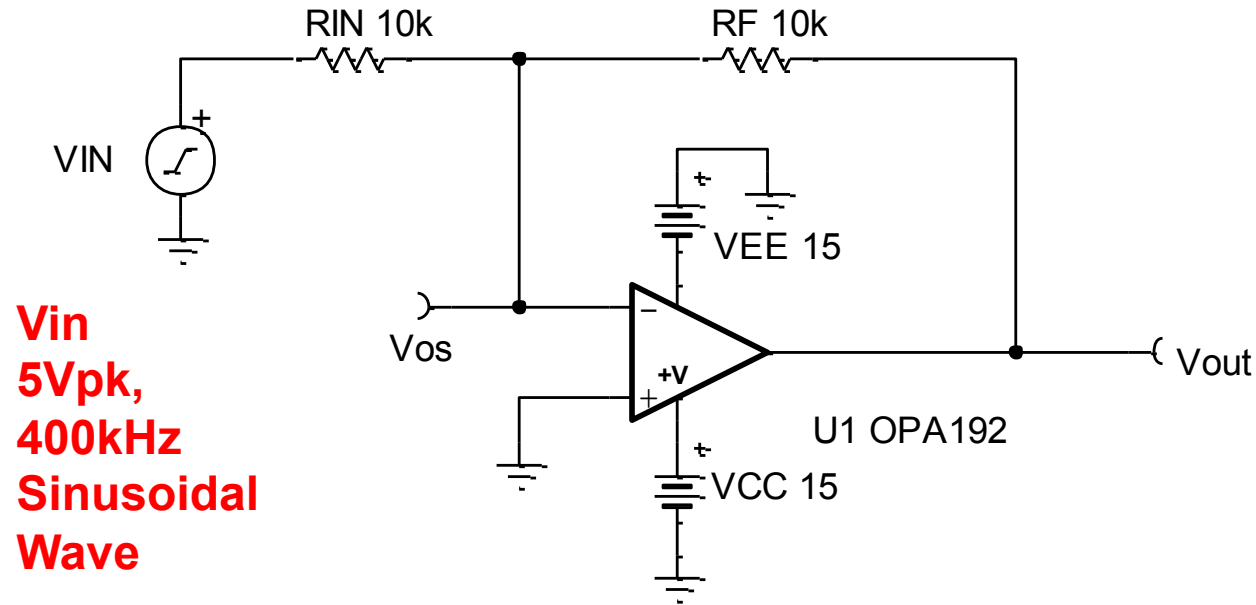

Slew Rate 1

Solutions

TI Precision Labs – Op Amps



1. Draw the output waveform for the circuit below and the excerpt from the data sheet. **The amplifier is inverting and will start to slew in the opposite direction to the applied signal. It will take 20us to fully transition the 20V step.** Confirm this result with simulation. Simulation result matches this

$$\tau_r = \frac{V_{PP}}{SR} = \frac{(20V)}{\left(0.8 \frac{V}{\mu s}\right)} = 25\mu s$$



1221 - Slew Rate 1 - Problem1.TSC

Simulated Output

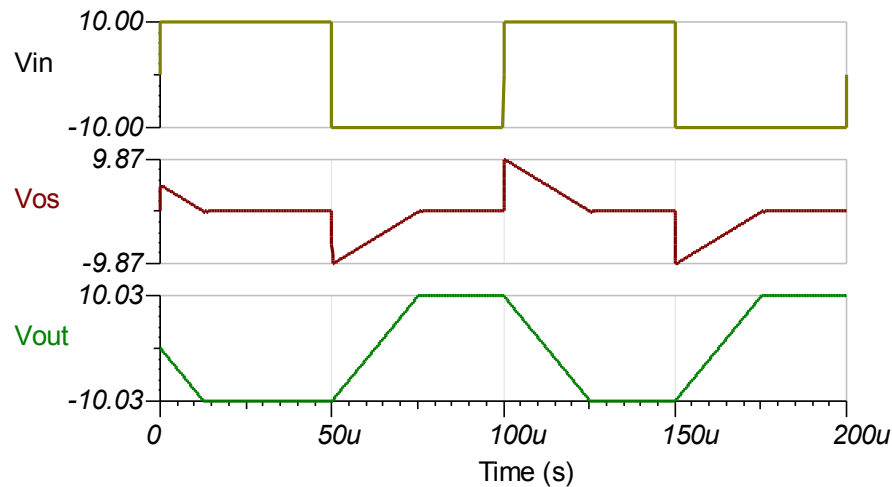

Draw Output

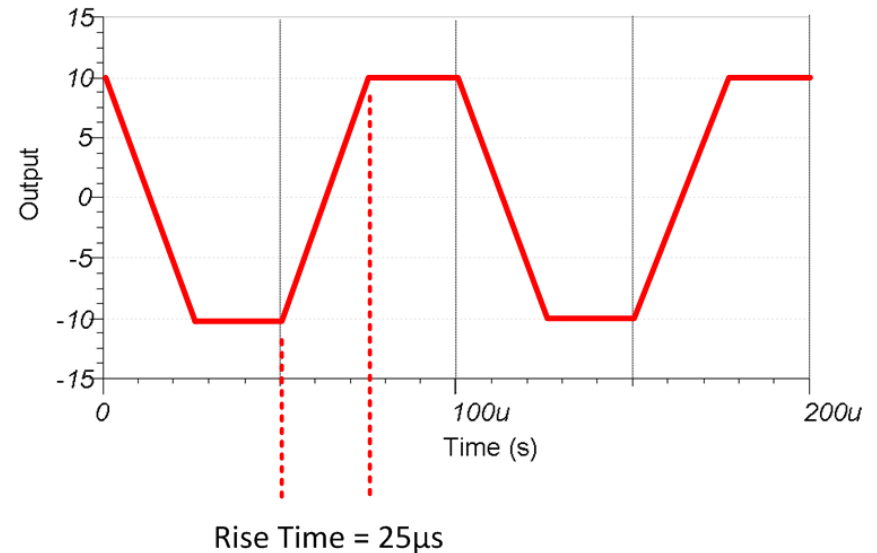

2. Why does the output waveform below have two different slopes?
This amplifier has slew boost. The output rise time reduces as the signal approaches its final value.

LARGE-SIGNAL STEP RESPONSE

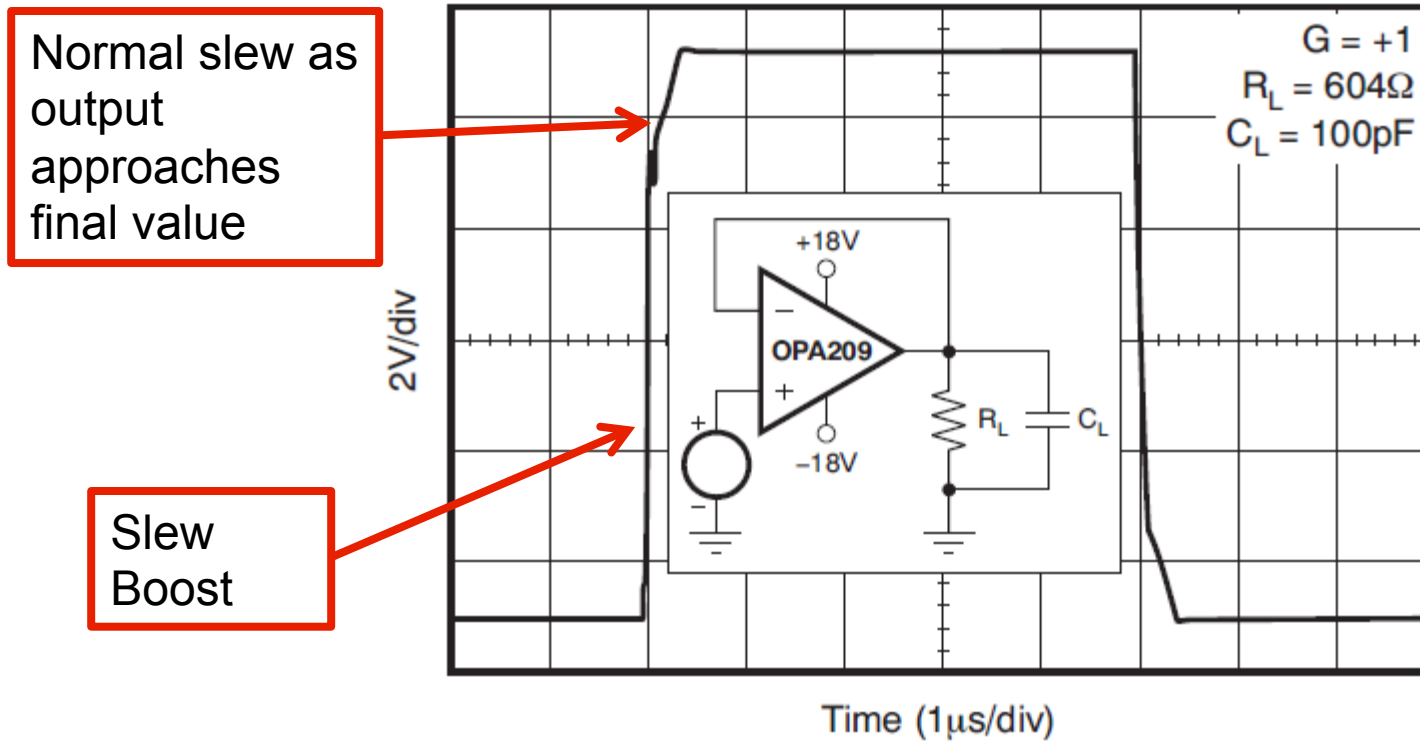

3. Will the circuit below have an issue with slew induced distortion? **No, the OPA192 can support up to 636kHz sinusoidal waveform 5Vpk.** What is the maximum 400kHz input signal that can be applied before significant slew induced distortion? **7.96Vpk** What is the bandwidth limit? **5MHz**

$$f_{\max} = \frac{SR}{2\pi \cdot V_p} = \frac{20 \frac{V}{\mu S}}{2 \cdot \pi \cdot (5V)} = 636\text{kHz}$$

$$V_p = \frac{SR}{2\pi \cdot f_{\max}} = \frac{20 \frac{V}{\mu s}}{2 \cdot \pi \cdot (400\text{kHz})} = 7.96\text{Vpk}$$

$$BW = \frac{GBW}{\frac{R_f}{R_1} + 1} = \frac{10\text{MHz}}{2} = 5\text{MHz}$$

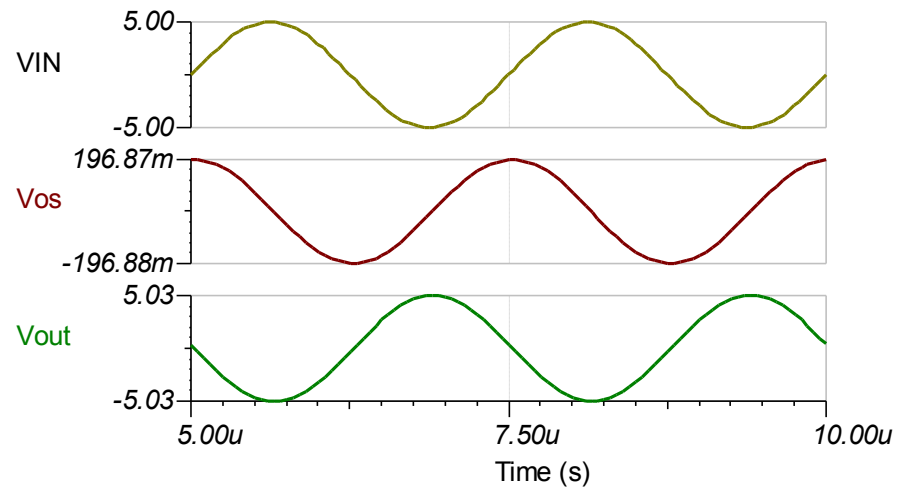

1221 - Slew Rate 1 - Problem3.TSC