

ADS7029-Q1 Small-Size, Low-Power, 8-Bit, 2-MSPS, SAR ADC

1 Features

- Qualified for Automotive Applications
- AEC-Q100 Qualified With the Following Results:
 - Device Temperature Grade 1: -40°C to 125°C Ambient Operating Temperature Range
 - Device HBM ESD Classification Level $\pm 2000\text{ V}$
 - Device CDM ESD Classification Level $\pm 1000\text{ V}$
- Ultra-Low Power Consumption:
 - 1.11 mW (max) at 2 MSPS with 3-V AVDD
 - Less Than $1\ \mu\text{W}$ at 1 kSPS with 3-V AVDD
- Miniature Footprint:
 - 8-Pin VSSOP Package: 2.30 mm x 2.00 mm
- 2-MSPS Throughput with Zero Data Latency
- Wide Operating Range:
 - AVDD: 2.35 V to 3.6 V
 - DVDD: 1.65 V to 3.6 V (Independent of AVDD)
 - Temperature Range: -40°C to $+125^{\circ}\text{C}$
- Excellent Performance:
 - 8-Bit Resolution with NMC
 - $\pm 0.2\text{ LSB DNL}$; $\pm 0.25\text{ LSB INL}$
 - 49-dB SNR with 3-V AVDD
 - -70-dB THD with 3-V AVDD
- Unipolar Input Range: 0 V to AVDD
- Integrated Offset Calibration
- SPI-Compatible Serial Interface: 32 MHz
- JESD8-7A Compliant Digital I/O

2 Applications

- Automotive Infotainment
- Automotive Sensors
- Level Sensors
- Ultrasonic Flow Meters
- Motor Control
- Portable Medical Equipment

3 Description

The ADS7029-Q1 device is an automotive Q100-qualified, 8-bit, 2-MSPS, analog-to-digital converter (ADC). The device supports a wide analog input voltage range (2.35 V to 3.6 V) and includes a capacitor-based, successive-approximation register (SAR) ADC with an inherent sample-and-hold circuit. The SPI-compatible serial interface is controlled by the $\overline{\text{CS}}$ and SCLK signals. The input signal is sampled with the $\overline{\text{CS}}$ falling edge and SCLK is used for conversion and serial data output. The device supports a wide digital supply range (1.65 V to 3.6 V), enabling direct interface to a variety of host controllers. The ADS7029-Q1 complies with the JESD8-7A standard for a normal DVDD range (1.65 V to 1.95 V).

The ADS7029-Q1 is available in an 8-pin, miniature, VSSOP package and is specified for operation from -40°C to $+125^{\circ}\text{C}$. The fast sampling rate of the ADS7029-Q1, along with miniature form-factor and low-power consumption, makes this device suitable for space-constrained and fast-scanning automotive applications.

Device Information⁽¹⁾

PART NAME	PACKAGE	BODY SIZE (NOM)
ADS7029-Q1	VSSOP (8)	2.30 mm x 2.00 mm

(1) For all available packages, see the orderable addendum at the end of the datasheet.

Typical Application

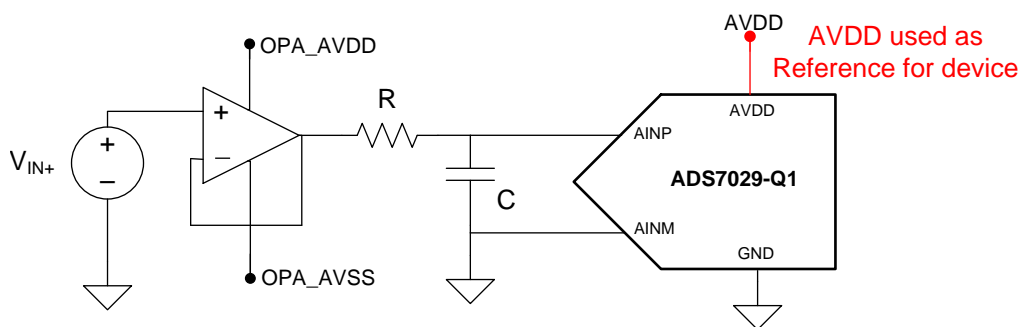

Copyright © 2016, Texas Instruments Incorporated



Table of Contents

1 Features	1	8.4 Device Functional Modes.....	17
2 Applications	1	9 Application and Implementation	20
3 Description	1	9.1 Application Information.....	20
4 Revision History	2	9.2 Typical Application	20
5 Pin Configuration and Functions	3	10 Power Supply Recommendations	23
6 Specifications	4	10.1 AVDD and DVDD Supply Recommendations.....	23
6.1 Absolute Maximum Ratings	4	10.2 Estimating Digital Power Consumption.....	23
6.2 ESD Ratings.....	4	10.3 Optimizing Power Consumed by the Device	23
6.3 Recommended Operating Conditions.....	4	11 Layout	24
6.4 Thermal Information	4	11.1 Layout Guidelines	24
6.5 Electrical Characteristics.....	5	11.2 Layout Example	24
6.6 Timing Requirements	6	12 Device and Documentation Support	25
6.7 Switching Characteristics	6	12.1 Documentation Support	25
6.8 Typical Characteristics	7	12.2 Receiving Notification of Documentation Updates	25
7 Parameter Measurement Information	12	12.3 Community Resources.....	25
7.1 Digital Voltage Levels	12	12.4 Trademarks	25
8 Detailed Description	12	12.5 Electrostatic Discharge Caution.....	25
8.1 Overview	12	12.6 Glossary	25
8.2 Functional Block Diagram	13	13 Mechanical, Packaging, and Orderable	25
8.3 Feature Description.....	13	Information	25

4 Revision History

DATE	REVISION	NOTES
January 2017	*	Initial release.

5 Pin Configuration and Functions

**DCU Package
8-Pin Leaded VSSOP
Top View**

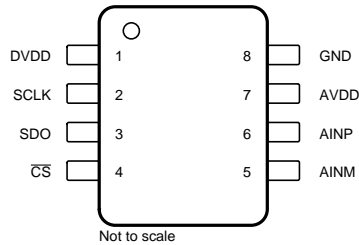

Not to scale

Pin Functions

NAME	NO.	I/O	DESCRIPTION
AINM	5	Analog input	Analog signal input, negative
AINP	6	Analog input	Analog signal input, positive
AVDD	7	Supply	Analog power-supply input, also provides the reference voltage to the ADC
$\overline{\text{CS}}$	4	Digital input	Chip-select signal, active low
DVDD	1	Supply	Digital I/O supply voltage
GND	8	Supply	Ground for power supply, all analog and digital signals are referred to this pin
SCLK	2	Digital input	Serial clock
SDO	3	Digital output	Serial data out

6 Specifications

6.1 Absolute Maximum Ratings⁽¹⁾

	MIN	MAX	UNIT
AVDD to GND	−0.3	3.9	V
DVDD to GND	−0.3	3.9	V
AINP to GND	−0.3	AVDD + 0.3	V
AINM to GND	−0.3	0.3	V
Digital input voltage to GND	−0.3	DVDD + 0.3	V
Storage temperature, T _{stg}	−60	150	°C

(1) Stresses beyond those listed under *Absolute Maximum Ratings* may cause permanent damage to the device. These are stress ratings only, which do not imply functional operation of the device at these or any other conditions beyond those indicated under *Recommended Operating Conditions*. Exposure to absolute-maximum-rated conditions for extended periods may affect device reliability.

6.2 ESD Ratings

		VALUE	UNIT
V _(ESD) Electrostatic discharge	Human-body model (HBM), per AEC Q100-002 ⁽¹⁾	±2000	V
	Charged-device model (CDM), per AEC Q100-011	±1000	

(1) AEC Q100-002 indicates that HBM stressing shall be in accordance with the ANSI/ESDA/JEDEC JS-001 specification.

6.3 Recommended Operating Conditions

over operating free-air temperature range (unless otherwise noted)

		MIN	NOM	MAX	UNIT
AVDD	Analog supply voltage range	2.35		3.6	V
DVDD	Digital supply voltage range	1.65		3.6	V
T _A	Operating free-air temperature	−40		125	°C

6.4 Thermal Information

THERMAL METRIC ⁽¹⁾		ADS7029-Q1	UNIT
		DCU (VSSOP)	
		8 PINS	
R _{θJA}	Junction-to-ambient thermal resistance	181.8	°C/W
R _{θJC(top)}	Junction-to-case (top) thermal resistance	50.8	°C/W
R _{θJB}	Junction-to-board thermal resistance	73.9	°C/W
ψ _{JT}	Junction-to-top characterization parameter	1.0	°C/W
ψ _{JB}	Junction-to-board characterization parameter	73.9	°C/W
R _{θJC(bot)}	Junction-to-case (bottom) thermal resistance	N/A	°C/W

(1) For more information about traditional and new thermal metrics, see the [Semiconductor and IC Package Thermal Metrics](#) application report.

6.5 Electrical Characteristics

at $T_A = -40^\circ\text{C}$ to 125°C , $AVDD = 3\text{ V}$, $DVDD = 1.65\text{ V}$ to 3.6 V , $f_{\text{SAMPLE}} = 2\text{ MSPS}$, and $V_{\text{AINM}} = 0\text{ V}$ (unless otherwise noted)

PARAMETER		TEST CONDITIONS	MIN	TYP	MAX	UNIT
ANALOG INPUT						
Full-scale input voltage span ⁽¹⁾			0		AVDD	V
Absolute input voltage range	AINP to GND		-0.1		AVDD + 0.1	V
	AINM to GND		-0.1		0.1	
C_S	Sampling capacitance			15		pF
SYSTEM PERFORMANCE						
Resolution				8		Bits
NMC	No missing codes		8			Bits
INL	Integral nonlinearity	AVDD = 3 V	-0.5	±0.25	0.5	LSB ⁽²⁾
DNL	Differential nonlinearity	AVDD = 3 V	-0.4	±0.2	0.4	LSB
E_O	Offset error			±0.5		LSB
dV_{OS}/dT	Offset error drift with temperature			±25		ppm/ $^\circ\text{C}$
E_G	Gain error	AVDD = 3 V		±0.2		%FS
	Gain error drift with temperature	No calibration		±25		ppm/ $^\circ\text{C}$
SAMPLING DYNAMICS						
t_{ACQ}	Acquisition time		120			ns
Maximum throughput rate		32-MHz SCLK, AVDD = 2.35 V to 3.6 V			2	MHz
DYNAMIC CHARACTERISTICS						
SNR	Signal-to-noise ratio ⁽³⁾	$f_{IN} = 2\text{ kHz}$, AVDD = 3 V	48.5	49		dB
THD	Total harmonic distortion ⁽³⁾⁽⁴⁾	$f_{IN} = 2\text{ kHz}$, AVDD = 3 V		-70		dB
SINAD	Signal-to-noise and distortion ⁽³⁾	$f_{IN} = 2\text{ kHz}$, AVDD = 3 V	48.5	49		dB
SFDR	Spurious-free dynamic range ⁽³⁾	$f_{IN} = 2\text{ kHz}$, AVDD = 3 V		75		dB
$BW_{(fp)}$	Full-power bandwidth	At -3 dB, AVDD = 3 V		25		MHz
DIGITAL INPUT/OUTPUT (CMOS Logic Family)						
V_{IH}	High-level input voltage ⁽⁵⁾		$0.65 \times DVDD$		$DVDD + 0.3$	V
V_{IL}	Low-level input voltage ⁽⁵⁾		-0.3		$0.35 \times DVDD$	V
V_{OH}	High-level output voltage ⁽⁵⁾	At $I_{source} = 500\ \mu\text{A}$	$0.8 \times DVDD$		DVDD	V
		At $I_{source} = 2\text{ mA}$	$DVDD - 0.45$		DVDD	
V_{OL}	Low-level output voltage ⁽⁵⁾	At $I_{sink} = 500\ \mu\text{A}$	0		$0.2 \times DVDD$	V
		At $I_{sink} = 2\text{ mA}$	0		0.45	
POWER-SUPPLY REQUIREMENTS						
AVDD	Analog supply voltage		2.35	3	3.6	V
DVDD	Digital I/O supply voltage		1.65	3	3.6	V
I_{AVDD}	Analog supply current	At 2 MSPS with AVDD = 3 V		335	370	μA
I_{DVDD}	Digital supply current	AVDD = 3 V, no load, no transitions		10		μA
P_D	Power dissipation	At 2 MSPS with AVDD = 3 V		1.005	1.11	mW

- (1) Ideal input span; does not include gain or offset error.
- (2) LSB means least significant bit.
- (3) All specifications expressed in decibels (dB) refer to the full-scale input (FSR) and are tested with an input signal 0.5 dB below full-scale, unless otherwise specified.
- (4) Calculated on the first nine harmonics of the input frequency.
- (5) Digital voltage levels comply with the JESD8-7A standard for DVDD from 1.65 V to 1.95 V; see the [Digital Voltage Levels](#) section for more details.

6.6 Timing Requirements

all specifications are at $T_A = -40^{\circ}\text{C}$ to 125°C , $\text{AVDD} = 2.35\text{ V}$ to 3.6 V , $\text{DVDD} = 1.65\text{ V}$ to 3.6 V , and C_{LOAD} on SDO = 20 pF (unless otherwise specified)

		MIN	TYP	MAX	UNIT
t_{ACQ}	Acquisition time	120			ns
f_{SCLK}	SCLK frequency	0.016		24	MHz
t_{SCLK}	SCLK period	41.67			ns
$t_{\text{PH_CK}}$	SCLK high time	0.45		0.55	t_{SCLK}
$t_{\text{PL_CK}}$	SCLK low time	0.45		0.55	t_{SCLK}
$t_{\text{PH_CS}}$	$\overline{\text{CS}}$ high time	30			ns
$t_{\text{SU_CSCK}}$	Setup time: $\overline{\text{CS}}$ falling to SCLK falling	12			ns
$t_{\text{D_CKCS}}$	Delay time: last SCLK falling to $\overline{\text{CS}}$ rising	10			ns

6.7 Switching Characteristics

all specifications are at $T_A = -40^{\circ}\text{C}$ to 125°C , $\text{AVDD} = 2.35\text{ V}$ to 3.6 V , $\text{DVDD} = 1.65\text{ V}$ to 3.6 V , and C_{LOAD} on SDO = 20 pF (unless otherwise specified)

PARAMETER	TEST CONDITIONS	MIN	TYP	MAX	UNIT
$f_{\text{THROUGHPUT}}$	Throughput			2	MSPS
t_{CYCLE}	Cycle time	0.5			μs
t_{CONV}	Conversion time		$8.5 \times t_{\text{SCLK}} + t_{\text{SU_CSCK}}$		ns
$t_{\text{DV_CSDO}}$	Delay time: $\overline{\text{CS}}$ falling to data enable			10	ns
$t_{\text{D_CKDO}}$	Delay time: SCLK falling to (next) data valid on DOUT		$\text{AVDD} = 2.35\text{ V to } 3.6\text{ V}$	25	ns
$t_{\text{DZ_CSDO}}$	Delay time: $\overline{\text{CS}}$ rising to DOUT going to tri-state	5			ns

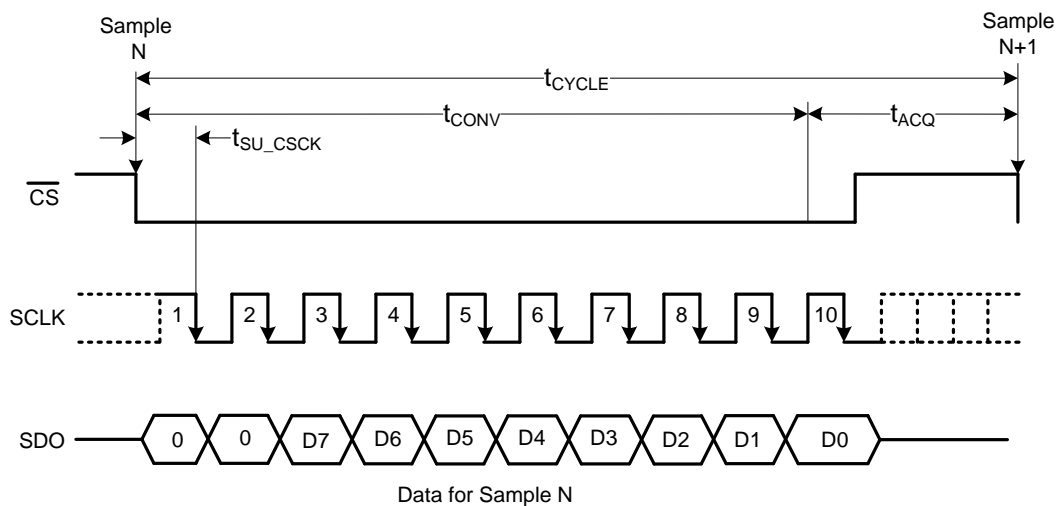
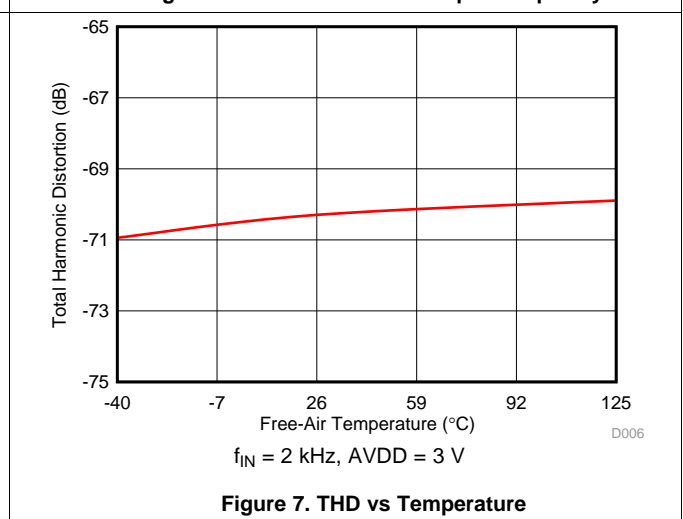
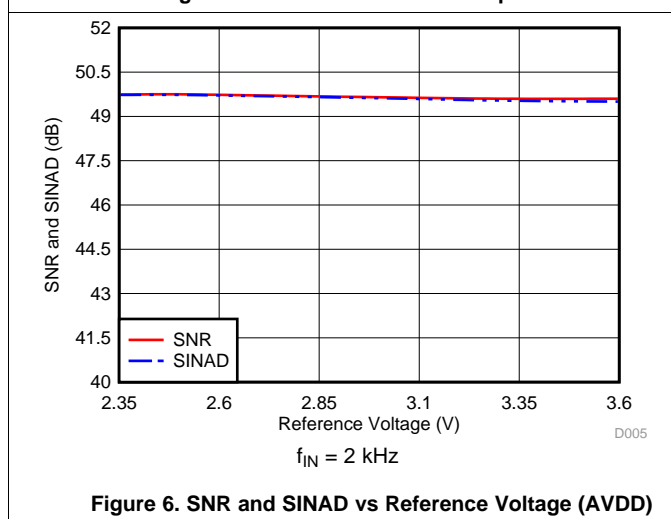
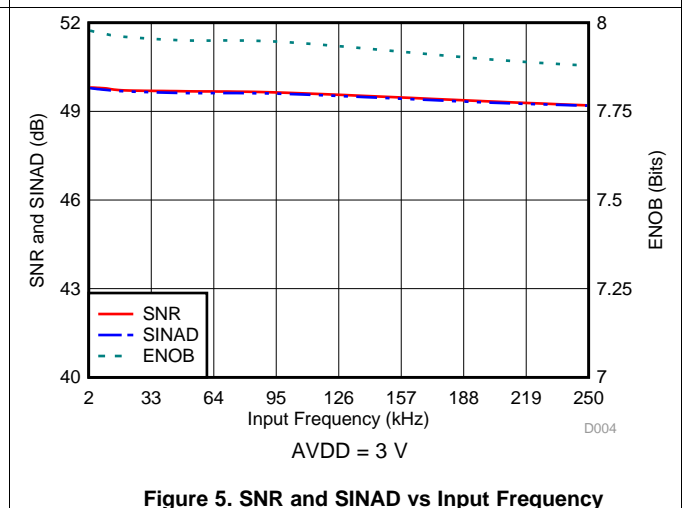
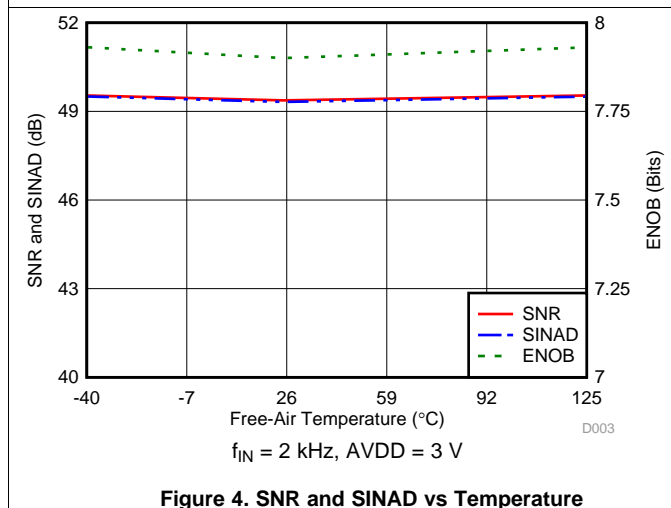
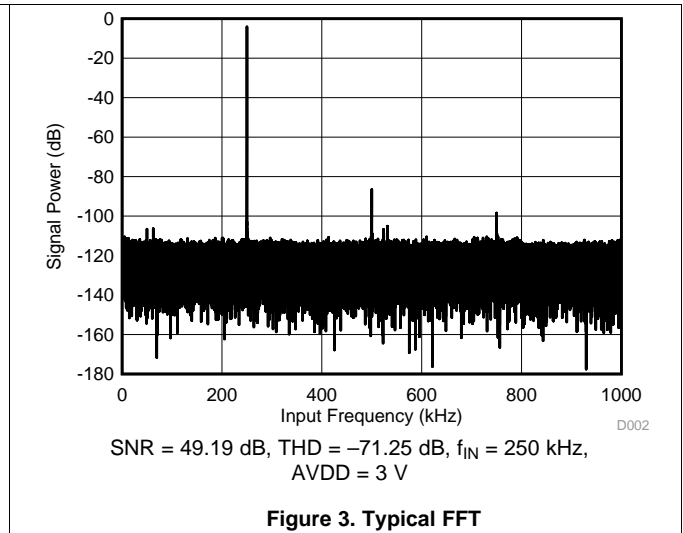
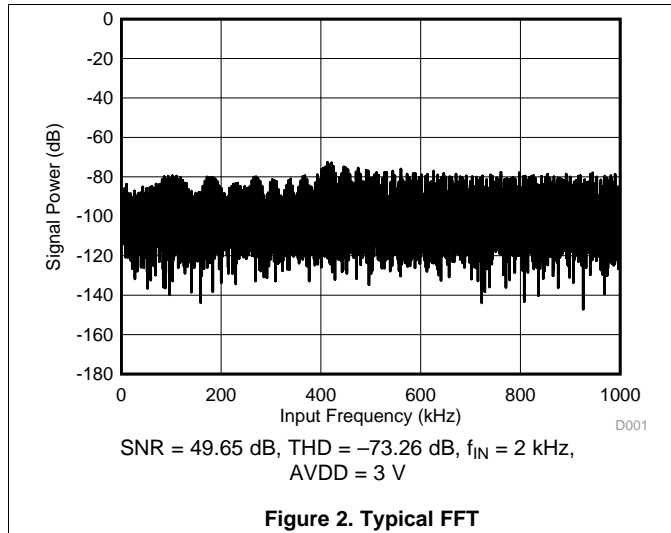

Figure 1. Timing Diagram

6.8 Typical Characteristics

at $T_A = 25^\circ\text{C}$, $AVDD = 3\text{ V}$, $DVDD = 1.8\text{ V}$, and $f_{\text{SAMPLE}} = 2\text{ MSPS}$ (unless otherwise noted)



Typical Characteristics (continued)

at $T_A = 25^\circ\text{C}$, $AVDD = 3\text{ V}$, $DVDD = 1.8\text{ V}$, and $f_{\text{SAMPLE}} = 2\text{ MSPS}$ (unless otherwise noted)

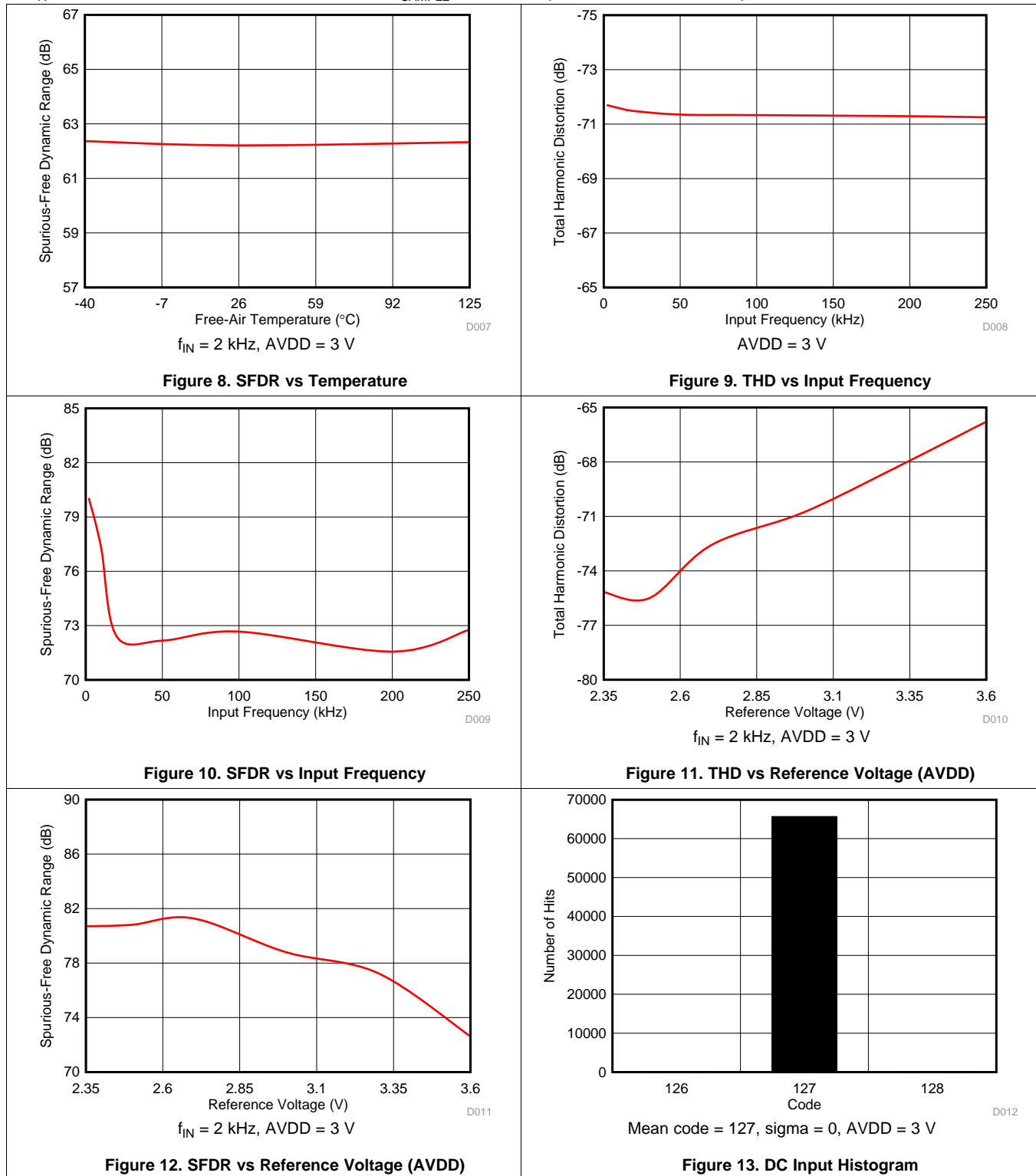

Typical Characteristics (continued)

at $T_A = 25^\circ\text{C}$, $AVDD = 3\text{ V}$, $DVDD = 1.8\text{ V}$, and $f_{\text{SAMPLE}} = 2\text{ MSPS}$ (unless otherwise noted)

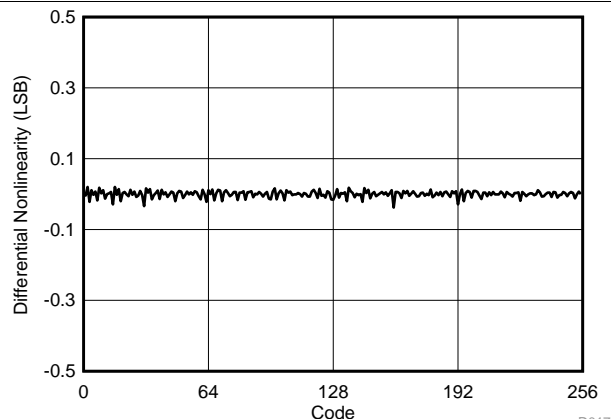

AVDD = 2.35 V

Figure 14. Typical DNL

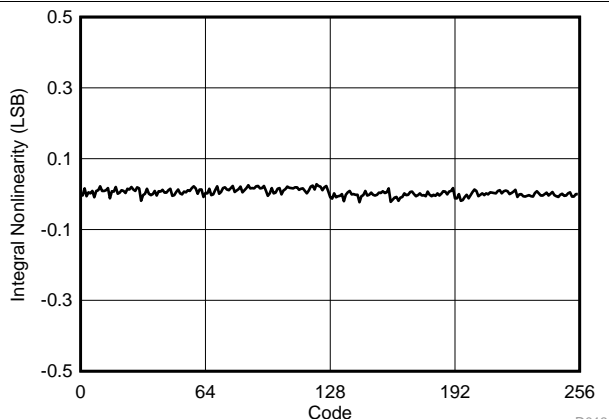

AVDD = 2.35 V

Figure 15. Typical INL

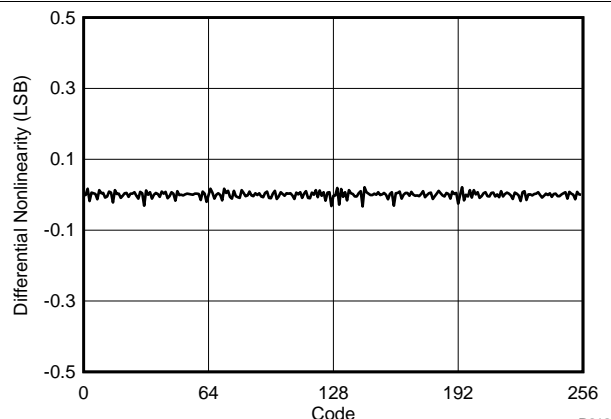

AVDD = 3 V

Figure 16. Typical DNL

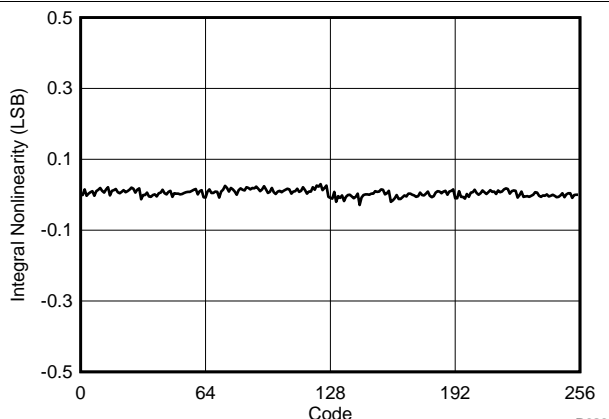

AVDD = 3 V

Figure 17. Typical INL

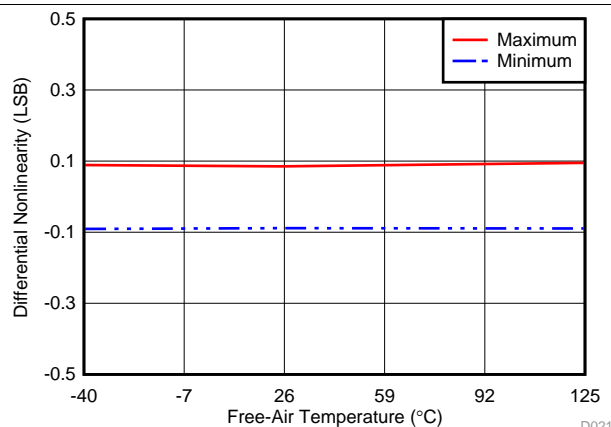

AVDD = 3 V

Figure 18. DNL vs Temperature

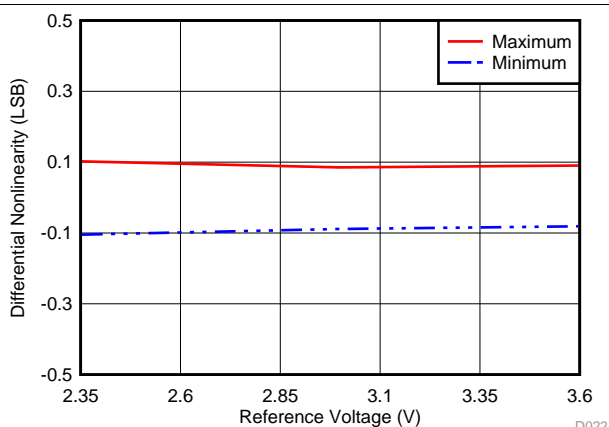
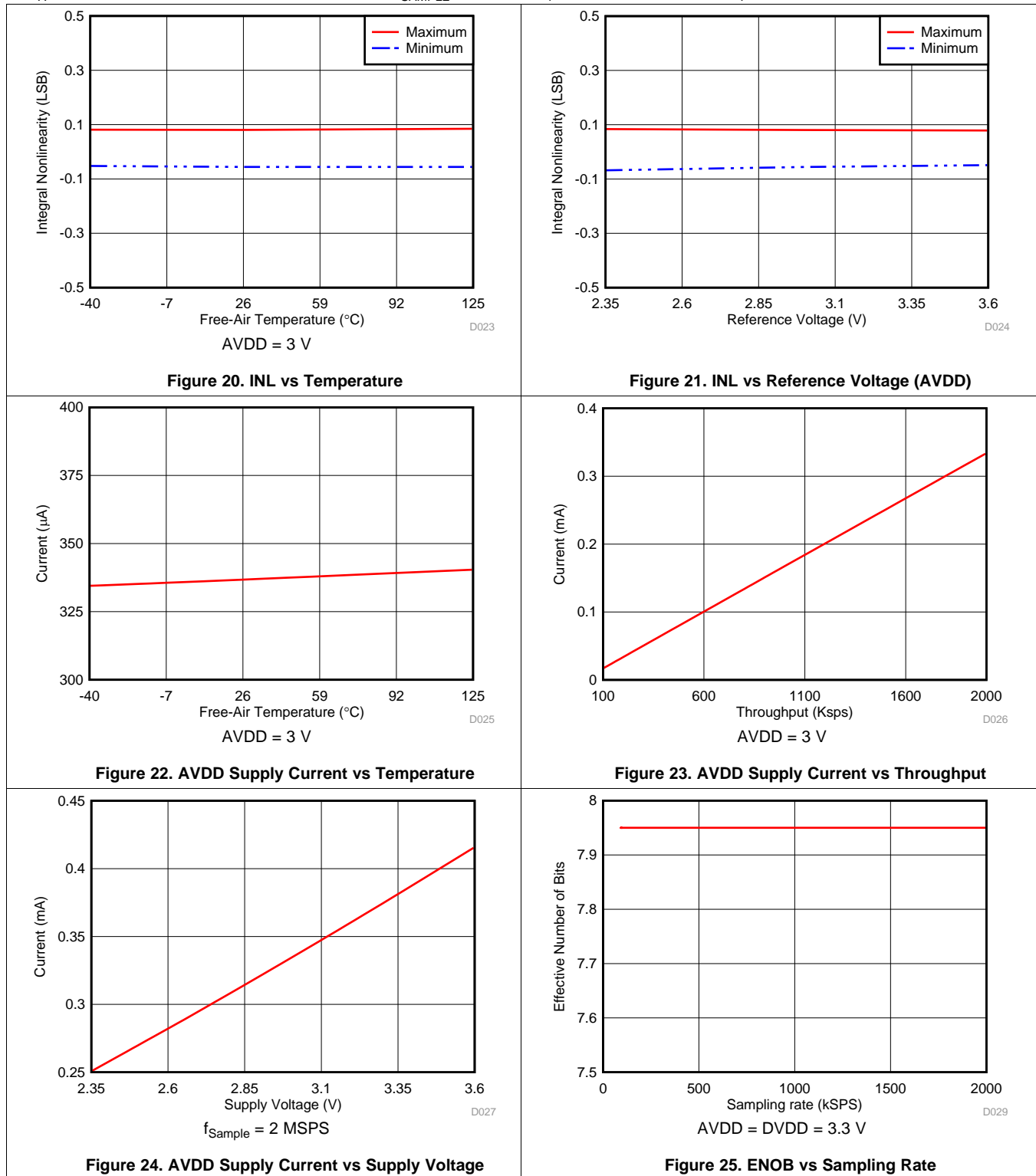

Figure 19. DNL vs Reference Voltage (AVDD)

Typical Characteristics (continued)

at $T_A = 25^\circ\text{C}$, $AVDD = 3\text{ V}$, $DVDD = 1.8\text{ V}$, and $f_{\text{SAMPLE}} = 2\text{ MSPS}$ (unless otherwise noted)



Typical Characteristics (continued)

at $T_A = 25^\circ\text{C}$, $AVDD = 3\text{ V}$, $DVDD = 1.8\text{ V}$, and $f_{\text{SAMPLE}} = 2\text{ MSPS}$ (unless otherwise noted)

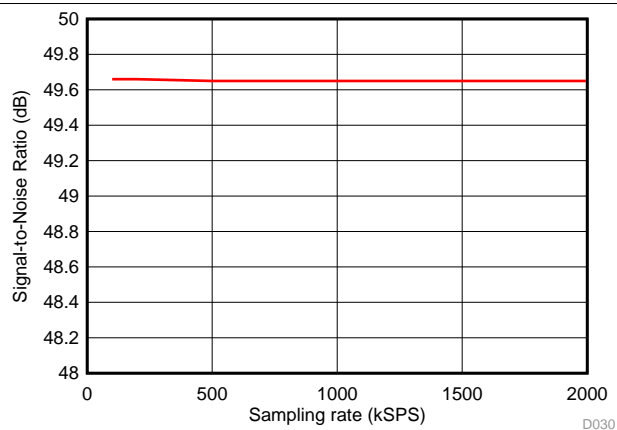

Figure 26. SNR vs Sampling Rate

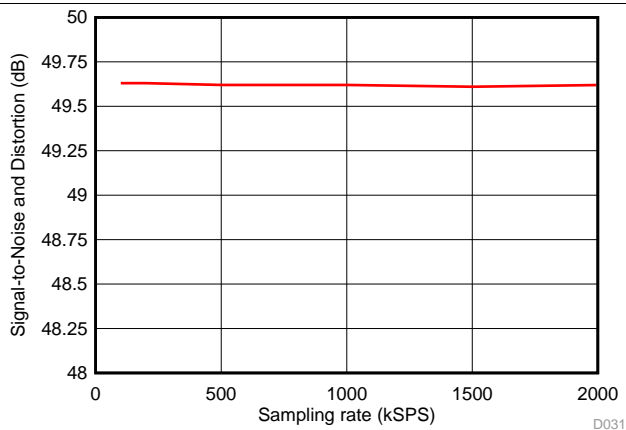

Figure 27. SINAD vs Sampling Rate

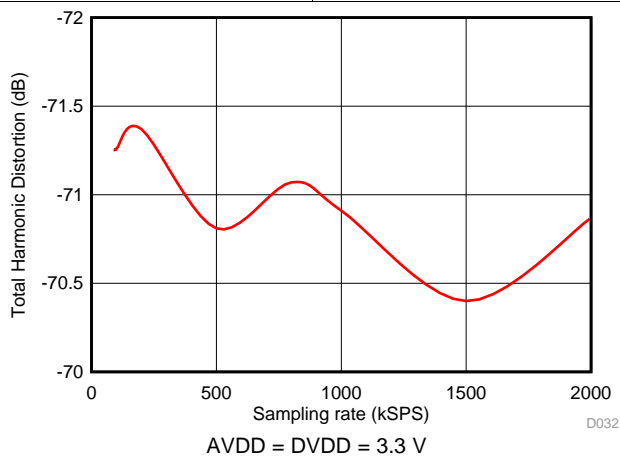

Figure 28. THD vs Sampling Rate

7 Parameter Measurement Information

7.1 Digital Voltage Levels

The device complies with the JESD8-7A standard for DVDD from 1.65 V to 1.95 V. Figure 29 shows voltage levels for the digital input and output pins.

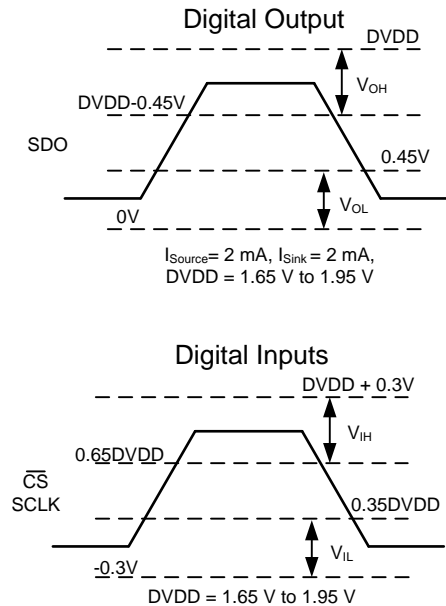

Figure 29. Digital Voltage Levels as per the JESD8-7A Standard

8 Detailed Description

8.1 Overview

The ADS7029-Q1 is an ultra-low-power, miniature analog-to-digital converter (ADC) that supports a wide analog input range. The analog input range for the device is defined by the AVDD supply voltage. The device samples the input voltage across the AINP and AINM pins on the \overline{CS} falling edge and starts the conversion. The clock provided on the SCLK pin is used for conversion and data transfer. During conversions, both the AINP and AINM pins are disconnected from the sampling circuit. After the conversion completes, the sampling capacitors are reconnected across the AINP and AINM pins and the ADS7029-Q1 enters acquisition phase.

The device has an internal offset calibration. The offset calibration can be initiated by the user either on power-up or during normal operation; see the [Offset Calibration](#) section for more details.

The device also provides a simple serial interface to the host controller and operates over a wide range of digital power supplies. The ADS7029-Q1 requires only a 24-MHz SCLK for supporting a throughput of 2 MSPS. The digital interface also complies with the JESD8-7A (normal range) standard. The [Functional Block Diagram](#) section provides a block diagram of the device.

8.2 Functional Block Diagram

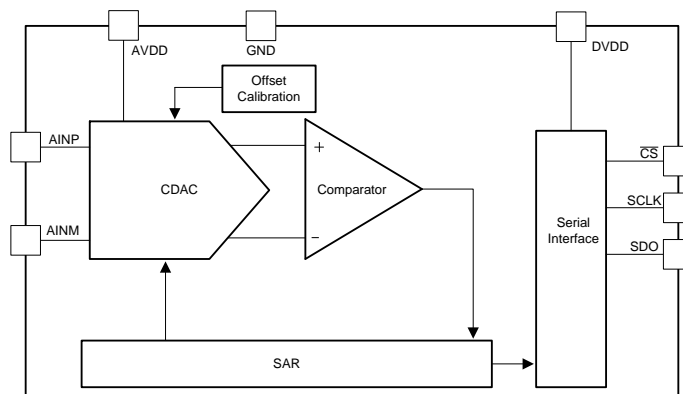

8.3 Feature Description

8.3.1 Reference

The device uses the analog supply voltage (AVDD) as a reference, as shown in [Figure 30](#). The AVDD pin is recommended to be decoupled with a 3.3- μ F, low equivalent series resistance (ESR) ceramic capacitor. The AVDD pin functions as a switched capacitor load to the source powering AVDD. The decoupling capacitor provides the instantaneous charge required by the internal circuit and helps in maintaining a stable dc voltage on the AVDD pin. The AVDD pin is recommended to be powered with a low output impedance and low-noise regulator (such as the [TPS73230](#)).

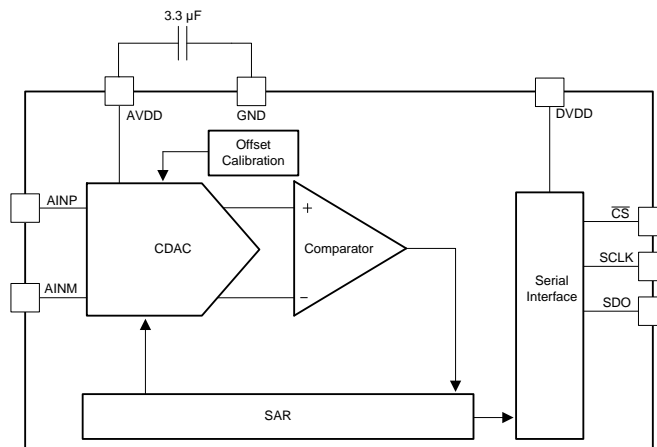

Figure 30. Reference for the Device

Feature Description (continued)

8.3.2 Analog Input

The device supports single-ended analog inputs. The ADC samples the difference between AINP and AINM and converts for this voltage. The device is capable of accepting a signal from -100 mV to 100 mV on the AINM input and is useful in systems where the sensor or signal-conditioning block is far from the ADC. In such a scenario, there can be a difference between the ground potential of the sensor or signal conditioner and the ADC ground. In such cases, use separate wires to connect the ground of the sensor or signal conditioner to the AINM pin. The AINP input is capable of accepting signals from 0 V to AVDD. [Figure 31](#) represents the equivalent analog input circuits for the sampling stage. The device has a low-pass filter followed by the sampling switch and sampling capacitor. The sampling switch is represented by an R_S (typically $50\ \Omega$) resistor in series with an ideal switch and C_S (typically 15 pF) is the sampling capacitor. The ESD diodes are connected from both analog inputs to AVDD and ground.

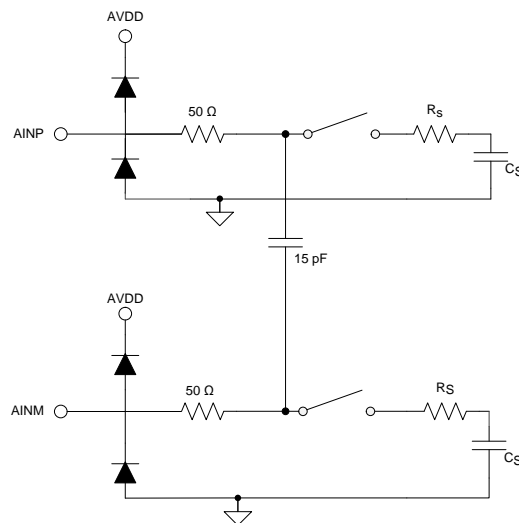

Figure 31. Equivalent Input Circuit for the Sampling Stage

The analog input full-scale range (FSR) is equal to the reference voltage of the ADC. The reference voltage for the device is equal to the analog supply voltage (AVDD). Thus, the device FSR can be determined by [Equation 1](#):

$$\text{FSR} = V_{\text{REF}} = \text{AVDD} \quad (1)$$

Feature Description (continued)

8.3.3 ADC Transfer Function

The device output is in straight binary format. The device resolution for a single-ended input can be computed by Equation 2:

$$1 \text{ LSB} = V_{\text{REF}} / 2^N$$

where:

- $V_{\text{REF}} = \text{AVDD}$ and
- $N = 8$

(2)

Figure 32 and Table 1 show the ideal transfer characteristics for the device.

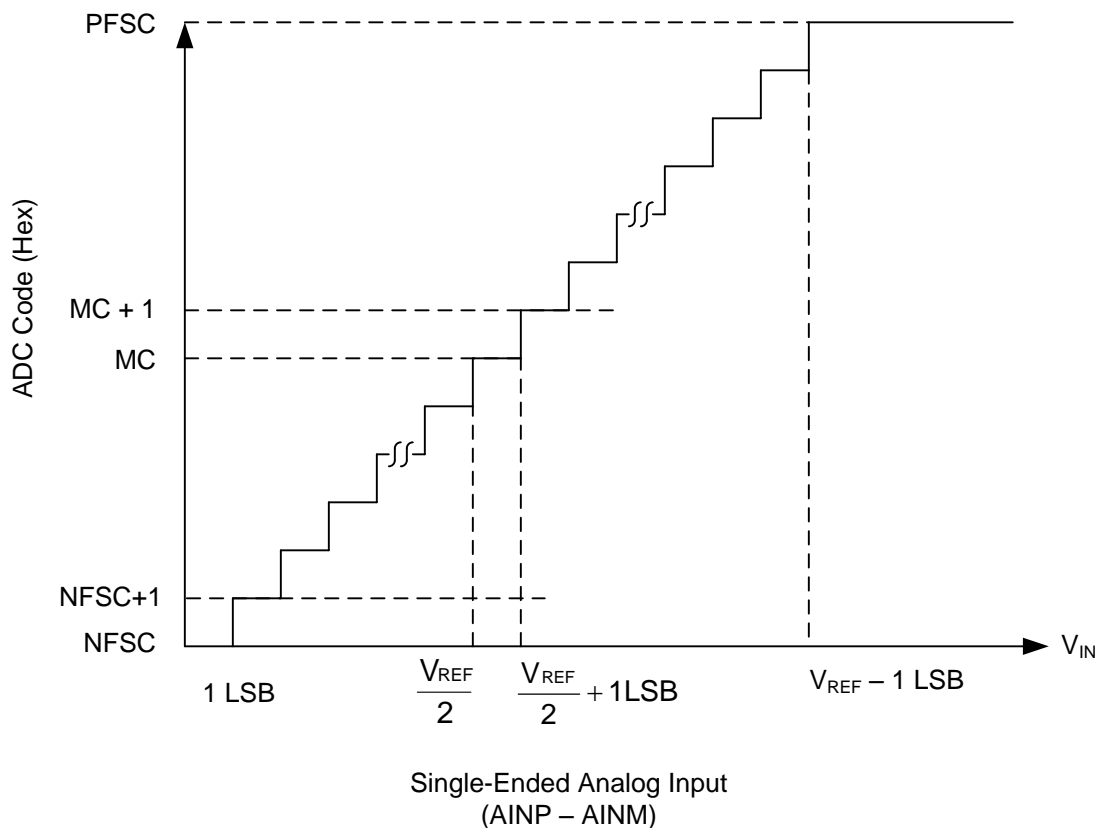

Figure 32. Ideal Transfer Characteristics

Table 1. Transfer Characteristics

INPUT VOLTAGE (AINP – AINM)	CODE	DESCRIPTION	IDEAL OUTPUT CODE (HEX)
$\leq 1 \text{ LSB}$	NFSC	Negative full-scale code	00
1 LSB to 2 LSBs	NFSC + 1	—	01
$(V_{\text{REF}} / 2)$ to $(V_{\text{REF}} / 2) + 1 \text{ LSB}$	MC	Mid code	80
$(V_{\text{REF}} / 2) + 1 \text{ LSB}$ to $(V_{\text{REF}} / 2) + 2 \text{ LSBs}$	MC + 1	—	81
$\geq V_{\text{REF}} - 1 \text{ LSB}$	PFSC	Positive full-scale code	FF

8.3.4 Serial Interface

The device supports a simple, SPI-compatible interface to the external host. The \overline{CS} signal defines one conversion and serial transfer frame. A frame starts with a \overline{CS} falling edge and ends with a \overline{CS} rising edge. The SDO pin outputs the ADC conversion results. Figure 33 shows a detailed timing diagram for the serial interface. A minimum delay of t_{SU_CSCK} must elapse between the \overline{CS} falling edge and the first SCLK falling edge. The device uses the clock provided on the SCLK pin for conversion and data transfer. The conversion result is available on the SDO pin with the first two bits set to 0, followed by 12 bits of the conversion result. The first zero is launched on the SDO pin on the \overline{CS} falling edge. Subsequent bits (starting with another 0 followed by the conversion result) are launched on the SDO pin on subsequent SCLK falling edges. The SDO output remains low after 14 SCLKs. A \overline{CS} rising edge ends the frame and brings the serial data bus to tri-state. For acquisition of the next sample, a minimum time of t_{ACQ} must be provided after the conversion of the current sample is completed. For details on timing specifications, see the [Timing Requirements](#) table.

The device initiates an offset calibration on the first \overline{CS} falling edge after power-up and the SDO output remains low during the first serial transfer frame after power-up. For further details, see the [Offset Calibration](#) section.

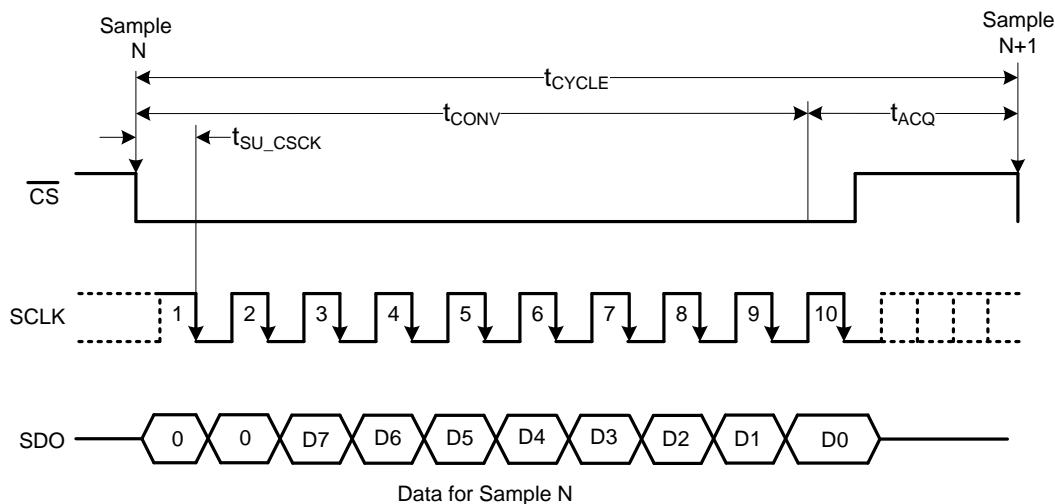
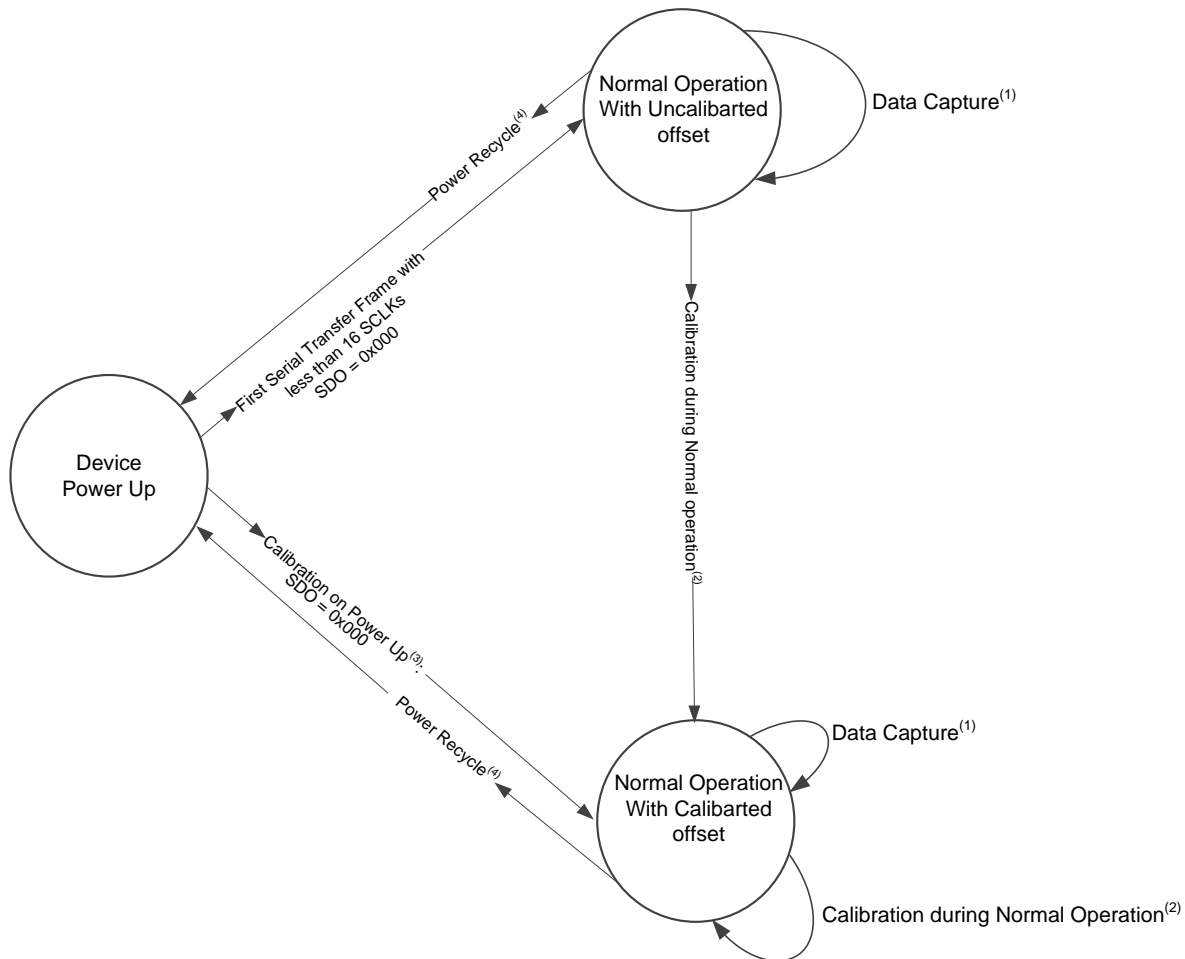

Figure 33. Serial Interface Timing Diagram

8.4 Device Functional Modes

8.4.1 Offset Calibration

The ADS7029-Q1 includes a feature to calibrate the device internal offset. During offset calibration, the analog input pins (AINP and AINM) are disconnected from the sampling stage. The device includes an internal offset calibration register (OCR) that stores the offset calibration result. The OCR is an internal register and cannot be accessed by the user through the serial interface. The OCR is reset to zero on power-up. Therefore, it is recommended to calibrate the offset on power-up in order to bring the offset error within the specified limits. If the operating temperature or analog supply voltage reflect a significant change, the offset can be recalibrated during normal operation. Figure 34 shows the offset calibration process.



- (1) See the [Timing Requirements](#) section for timing specifications.
- (2) See the [Offset Calibration During Normal Operation](#) section for details.
- (3) See the [Offset Calibration on Power-Up](#) section for details.
- (4) The power recycle on the AVDD supply is required to reset the offset calibration and to bring the device to a power-up state.

Figure 34. Offset Calibration

Device Functional Modes (continued)

8.4.1.1 Offset Calibration on Power-Up

The device initiates offset calibration on the first \overline{CS} falling edge after power-up and calibration completes if the \overline{CS} pin remains low for at least 16 SCLK falling edges after the first \overline{CS} falling edge. The SDO output remains low during calibration. The minimum acquisition time must be provided after calibration for acquiring the first sample. If the device is not provided with at least 16 SCLKs during the first serial transfer frame after power-up, the OCR is not updated. Table 2 provides the timing parameters for offset calibration on power-up.

For subsequent samples, the device adjusts the conversion results with the value stored in the OCR. The conversion result adjusted with the value stored in OCR is provided by the device on the SDO output. Figure 35 shows the timing diagram for offset calibration on power-up.

Table 2. Offset Calibration on Power-Up

		MIN	TYP	MAX	UNIT
$f_{CLK-CAL}$	SCLK frequency for calibration			12	MHz
$t_{POWERUP-CAL}$	Calibration time at power-up	$15 \times t_{SCLK}$			ns
t_{ACQ}	Acquisition time	120			ns
t_{PH-CS}	\overline{CS} high time	t_{ACQ}			ns
$t_{SU-CSCK}$	Setup time: \overline{CS} falling to SCLK falling	12			ns
t_{D-CKCS}	Delay time: last SCLK falling to \overline{CS} rising	10			ns

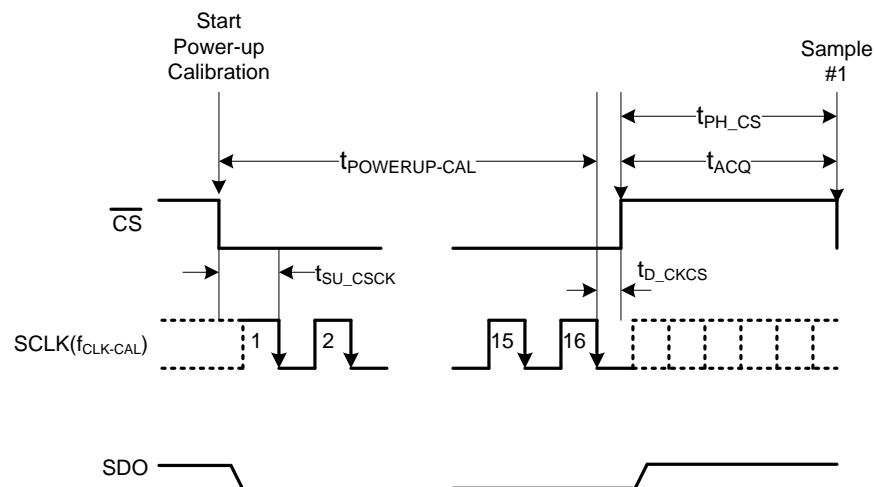

Figure 35. Offset Calibration on Power-Up Timing Diagram

8.4.1.2 Offset Calibration During Normal Operation

Offset calibration can be done during normal device operation if at least 32 SCLK falling edges are provided in one serial transfer frame. During the first 10 SCLKs, the device converts the sample acquired on the CS falling edge and provides data on the SDO output. The device initiates the offset calibration on the 17th SCLK falling edge and calibration completes on the 32nd SCLK falling edge. The SDO output remains low after the 10th SCLK falling edge and SDO goes to tri-state after CS goes high. If the device is provided with less than 32 SCLKs during a serial transfer frame, the OCR is not updated. Table 3 provides the timing parameters for offset calibration during normal operation.

For subsequent samples, the device adjusts the conversion results with the value stored in the OCR. The conversion result adjusted with the value stored in the OCR is provided by the device on the SDO output. Figure 36 shows the timing diagram for offset calibration during normal operation.

Table 3. Offset Calibration During Normal Operation

		MIN	TYP	MAX	UNIT
$f_{\text{CLK-CAL}}$	SCLK frequency for calibration			12	MHz
t_{CAL}	Calibration time during normal operation	$15 \times t_{\text{SCLK}}$			ns
t_{ACQ}	Acquisition time	120			ns
$t_{\text{PH-CS}}$	CS high time	t_{ACQ}			ns
$t_{\text{SU-CSCK}}$	Setup time: CS falling to SCLK falling	12			ns
$t_{\text{D-CKCS}}$	Delay time: last SCLK falling to CS rising	10			ns

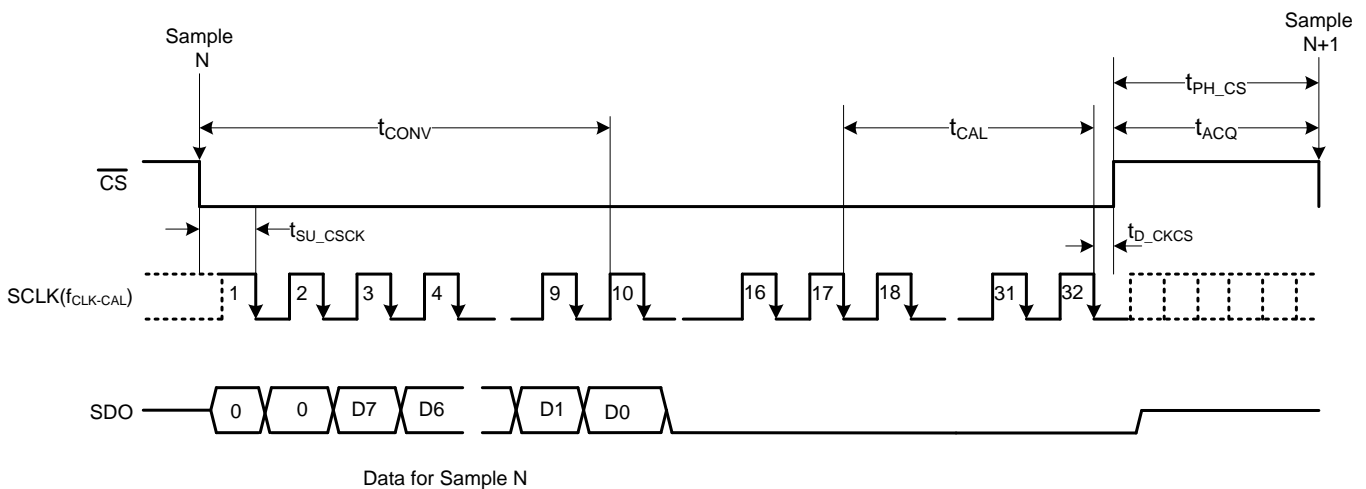

Figure 36. Offset Calibration During Normal Operation Timing Diagram

9 Application and Implementation

NOTE

Information in the following applications sections is not part of the TI component specification, and TI does not warrant its accuracy or completeness. TI's customers are responsible for determining suitability of components for their purposes. Customers should validate and test their design implementation to confirm system functionality.

9.1 Application Information

The two primary circuits required to maximize the performance of a SAR ADC are the input driver and the reference driver circuits. This section details some general principles for designing the input driver circuit, reference driver circuit, and provides some application circuits designed for the ADS7029-Q1.

9.2 Typical Application

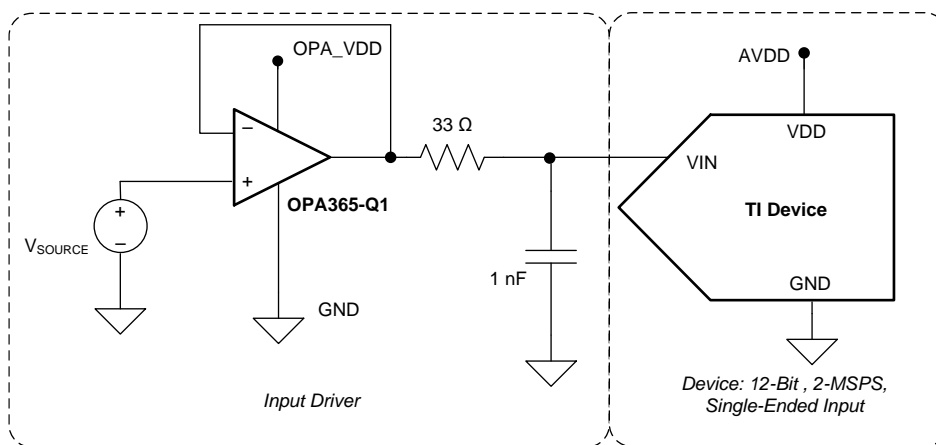

Copyright © 2016, Texas Instruments Incorporated

Figure 37. Single-Supply DAQ with the ADS7029-Q1

9.2.1 Design Requirements

The goal of this application is to design a single-supply digital acquisition (DAQ) circuit based on the ADS7029-Q1 with SNR greater than 49 dB and THD less than -70 dB for input frequencies of 2 kHz at a throughput of 2 MSPS.

9.2.2 Detailed Design Procedure

The input driver circuit for a high-precision ADC mainly consists of two parts: a driving amplifier and a charge kickback filter. Careful design of the front-end circuit is critical to meet the linearity and noise performance of a high-precision ADC.

Typical Application (continued)

9.2.2.1 Low Distortion Charge Kickback Filter Design

Figure 38 shows the input circuit of a typical SAR ADC. During the acquisition phase, the SW switch closes and connects the sampling capacitor (C_{SH}) to the input driver circuit. This action introduces a transient on the input pins of the SAR ADC. An ideal amplifier with $0\ \Omega$ of output impedance and infinite current drive can settle this transient in zero time. For a real amplifier with non-zero output impedance and finite drive strength, this switched capacitor load can create stability issues.

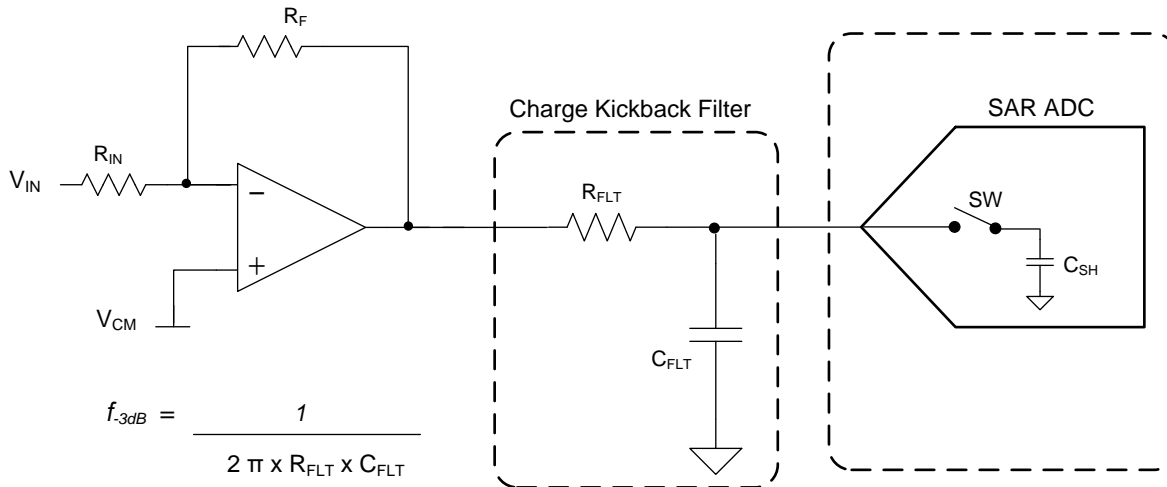

Figure 38. Charge Kickback Filter

For ac signals, the filter bandwidth must be kept low to band limit the noise fed into the ADC input, thereby increasing the SNR of the system. Besides filtering the noise from the front-end drive circuitry, the RC filter also helps attenuate the sampling charge injection from the switched-capacitor input stage of the ADC. A filter capacitor, C_{FLT} , is connected across the ADC inputs. This capacitor helps reduce the sampling charge injection and provides a charge bucket to quickly charge the internal sample-and-hold capacitors during the acquisition process. As a rule of thumb, the value of this capacitor is at least 20 times the specified value of the ADC sampling capacitance. For this device, the input sampling capacitance is equal to 15 pF. Thus, the value of C_{FLT} is greater than 300 pF. Select a COG- or NPO-type capacitor because these capacitor types have a high-Q, low-temperature coefficient, and stable electrical characteristics under varying voltages, frequency, and time.

Note that driving capacitive loads can degrade the phase margin of the input amplifiers, thus making the amplifier marginally unstable. To avoid amplifier stability issues, series isolation resistors (R_{FLT}) are used at the output of the amplifiers. A higher value of R_{FLT} is helpful from the amplifier stability perspective, but adds distortion as a result of interactions with the nonlinear input impedance of the ADC. Distortion increases with source impedance, input signal frequency, and input signal amplitude. Therefore, the selection of R_{FLT} requires balancing the stability and distortion of the design.

The input amplifier bandwidth is typically much higher than the cutoff frequency of the antialiasing filter. Thus, a SPICE simulation is strongly recommended to be performed to confirm that the amplifier has more than 40° phase margin with the selected filter. Simulation is critical because even with high-bandwidth amplifiers, some amplifiers can require more bandwidth than others to drive similar filters.

Typical Application (continued)

9.2.2.2 Input Amplifier Selection

To achieve a SINAD greater than 49 dB, the operational amplifier must have high bandwidth in order to settle the input signal within the acquisition time of the ADC. The operational amplifier must have low noise to keep the total system noise below 20% of the input-referred noise of the ADC. For the application circuit illustrated in [Figure 37](#), the [OPA365-Q1](#) is selected for its high bandwidth (50 MHz) and low noise (4.5 nV/√Hz).

For a step-by-step design procedure for a low-power, small form-factor digital acquisition (DAQ) circuit based on similar SAR ADCs, see the [Three 12-Bit Data Acquisition Reference Designs Optimized for Low Power and Ultra-Small Form Factor](#) TI Precision Design.

9.2.2.3 Reference Circuit

The analog supply voltage of the device is also used as a voltage reference for conversion. The AVDD pin is recommended to be decoupled with a 3.3-μF, low-ESR ceramic capacitor.

9.2.3 Application Curve

[Figure 39](#) shows the FFT plot for the ADS7029-Q1 with a 2-kHz input frequency used for the circuit in [Figure 37](#).

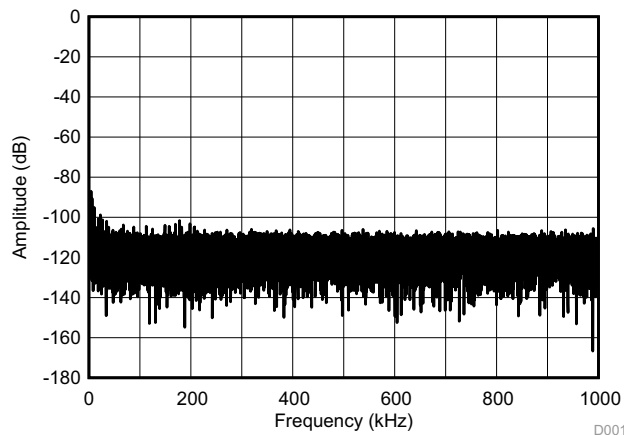

SNR = 70.6 dB, THD = -86 dB, SINAD = 70.2 dB, number of samples = 32768

Figure 39. Test Results for the ADS7029-Q1 and OPA365-Q1 for a 2-kHz Input

10 Power Supply Recommendations

10.1 AVDD and DVDD Supply Recommendations

The ADS7029-Q1 has two separate power supplies: AVDD and DVDD. The device operates on AVDD; DVDD is used for the interface circuits. AVDD and DVDD can be independently set to any value within the permissible ranges. The AVDD supply also defines the full-scale input range of the device. Always set the AVDD supply to be greater than or equal to the maximum input signal to avoid saturation of codes. Decouple the AVDD and DVDD pins individually with 3.3- μ F ceramic decoupling capacitors, as shown in [Figure 40](#).

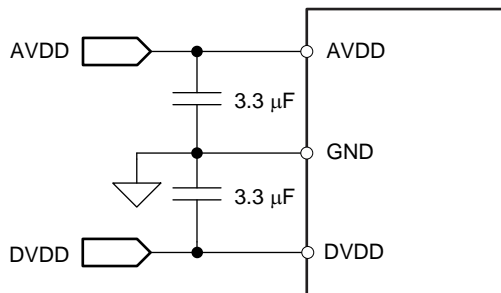

Figure 40. Power-Supply Decoupling

10.2 Estimating Digital Power Consumption

The current consumption from the DVDD supply depends on the DVDD voltage, load capacitance on the SDO line, and the output code. The load capacitance on the SDO line is charged by the current from the SDO pin on every rising edge of the data output and is discharged on every falling edge of the data output. The current consumed by the device from the DVDD supply can be calculated by [Equation 3](#):

$$I_{DVDD} = C \times V \times f$$

where:

- C = Load capacitance on the SDO line
 - V = DVDD supply voltage and
 - f = Number of transitions on the SDO output
- (3)

The number of transitions on the SDO output depends on the output code, and thus changes with the analog input. The maximum value of f occurs when data output on SDO change at every SCLK. SDO data changing at every SCLK results in an output code of AAh or 55h. For an output code of AAh or 55h at a 2-MSPS throughput, the frequency of transitions on the SDO output is 8 MHz.

For the current consumption to remain at the lowest possible value, keep the DVDD supply at the lowest permissible value and keep the capacitance on the SDO line as low as possible.

10.3 Optimizing Power Consumed by the Device

- Keep the analog supply voltage (AVDD) as close as possible to the analog input voltage. Set AVDD to be greater than or equal to the analog input voltage of the device.
- Keep the digital supply voltage (DVDD) at the lowest permissible value.
- Reduce the load capacitance on the SDO output.
- Run the device at the optimum throughput. Power consumption reduces with throughput.

11 Layout

11.1 Layout Guidelines

Figure 41 shows a board layout example for the ADS7029-Q1.

Some of the key considerations for an optimum layout with this device are:

- Use a ground plane underneath the device and partition the printed circuit board (PCB) into analog and digital sections.
- Avoid crossing digital lines with the analog signal path and keep the analog input signals and the reference input signals away from noise sources.
- The power sources to the device must be clean and well-bypassed. Use 2.2- μF ceramic bypass capacitors in close proximity to the analog (AVDD) and digital (DVDD) power-supply pins.
- Avoid placing vias between the AVDD and DVDD pins and the bypass capacitors.
- Connect ground pins to the ground plane using short, low-impedance path.
- Place the fly-wheel RC filters components close to the device.

Among ceramic surface-mount capacitors, COG (NPO) ceramic capacitors provide the best capacitance precision. The type of dielectric used in COG (NPO) ceramic capacitors provides the most stable electrical properties over voltage, frequency, and temperature changes.

11.2 Layout Example

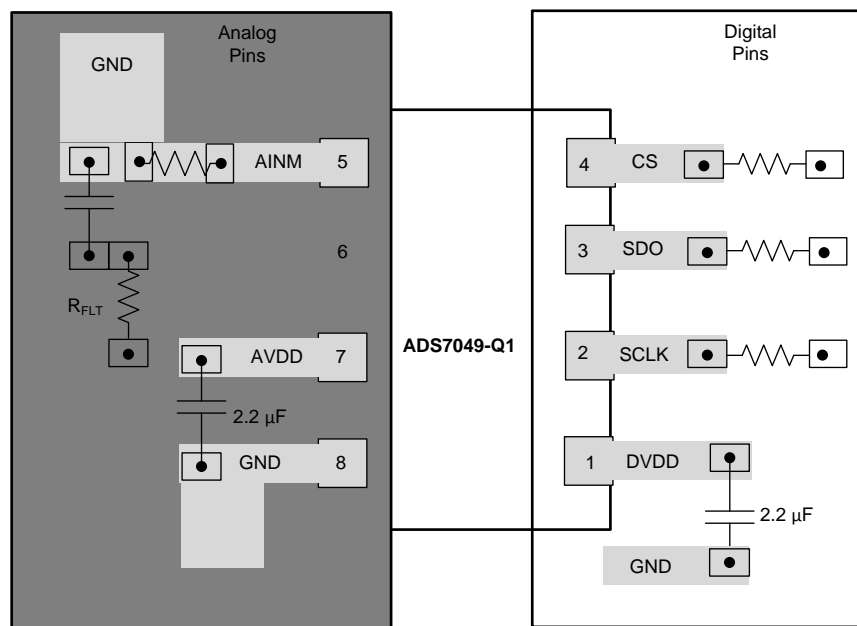

Copyright © 2016, Texas Instruments Incorporated

Figure 41. Example Layout

12 Device and Documentation Support

12.1 Documentation Support

12.1.1 Related Documentation

For related documentation see the following:

- [TPS732xx Capacitor-Free, NMOS, 250-mA Low-Dropout Regulator With Reverse Current Protection](#)
- [Three 12-Bit Data Acquisition Reference Designs Optimized for Low Power and Ultra-Small Form Factor TI Precision Design](#)
- [OPAx314 3-MHz, Low-Power, Low-Noise, RRIO, 1.8-V CMOS Operational Amplifier](#)
- [OPAx365-Q1 50-MHz Low-Distortion High-CMRR Rail-to-Rail I/O, Single-Supply Operational Amplifiers](#)

12.2 Receiving Notification of Documentation Updates

To receive notification of documentation updates, navigate to the device product folder on ti.com. In the upper right corner, click on *Alert me* to register and receive a weekly digest of any product information that has changed. For change details, review the revision history included in any revised document.

12.3 Community Resources

The following links connect to TI community resources. Linked contents are provided "AS IS" by the respective contributors. They do not constitute TI specifications and do not necessarily reflect TI's views; see TI's [Terms of Use](#).

TI E2E™ Online Community *TI's Engineer-to-Engineer (E2E) Community*. Created to foster collaboration among engineers. At e2e.ti.com, you can ask questions, share knowledge, explore ideas and help solve problems with fellow engineers.

Design Support *TI's Design Support* Quickly find helpful E2E forums along with design support tools and contact information for technical support.

12.4 Trademarks

E2E is a trademark of Texas Instruments.
All other trademarks are the property of their respective owners.

12.5 Electrostatic Discharge Caution



This integrated circuit can be damaged by ESD. Texas Instruments recommends that all integrated circuits be handled with appropriate precautions. Failure to observe proper handling and installation procedures can cause damage.

ESD damage can range from subtle performance degradation to complete device failure. Precision integrated circuits may be more susceptible to damage because very small parametric changes could cause the device not to meet its published specifications.

12.6 Glossary

[SLYZ022](#) — *TI Glossary*.

This glossary lists and explains terms, acronyms, and definitions.

13 Mechanical, Packaging, and Orderable Information

The following pages include mechanical packaging and orderable information. This information is the most current data available for the designated devices. This data is subject to change without notice and revision of this document. For browser-based versions of this data sheet, refer to the left-hand navigation.

PACKAGING INFORMATION

Orderable Device	Status (1)	Package Type	Package Drawing	Pins	Package Qty	Eco Plan (2)	Lead finish/ Ball material (6)	MSL Peak Temp (3)	Op Temp (°C)	Device Marking (4/5)	Samples
ADS7029QDCURQ1	ACTIVE	VSSOP	DCU	8	3000	RoHS & Green	NIPDAU	Level-2-260C-1 YEAR	-40 to 125	17TT	Samples

(1) The marketing status values are defined as follows:

ACTIVE: Product device recommended for new designs.

LIFEBUY: TI has announced that the device will be discontinued, and a lifetime-buy period is in effect.

NRND: Not recommended for new designs. Device is in production to support existing customers, but TI does not recommend using this part in a new design.

PREVIEW: Device has been announced but is not in production. Samples may or may not be available.

OBSOLETE: TI has discontinued the production of the device.

(2) **RoHS:** TI defines "RoHS" to mean semiconductor products that are compliant with the current EU RoHS requirements for all 10 RoHS substances, including the requirement that RoHS substance do not exceed 0.1% by weight in homogeneous materials. Where designed to be soldered at high temperatures, "RoHS" products are suitable for use in specified lead-free processes. TI may reference these types of products as "Pb-Free".

RoHS Exempt: TI defines "RoHS Exempt" to mean products that contain lead but are compliant with EU RoHS pursuant to a specific EU RoHS exemption.

Green: TI defines "Green" to mean the content of Chlorine (Cl) and Bromine (Br) based flame retardants meet JS709B low halogen requirements of <=1000ppm threshold. Antimony trioxide based flame retardants must also meet the <=1000ppm threshold requirement.

(3) MSL, Peak Temp. - The Moisture Sensitivity Level rating according to the JEDEC industry standard classifications, and peak solder temperature.

(4) There may be additional marking, which relates to the logo, the lot trace code information, or the environmental category on the device.

(5) Multiple Device Markings will be inside parentheses. Only one Device Marking contained in parentheses and separated by a "-" will appear on a device. If a line is indented then it is a continuation of the previous line and the two combined represent the entire Device Marking for that device.

(6) Lead finish/Ball material - Orderable Devices may have multiple material finish options. Finish options are separated by a vertical ruled line. Lead finish/Ball material values may wrap to two lines if the finish value exceeds the maximum column width.

Important Information and Disclaimer:The information provided on this page represents TI's knowledge and belief as of the date that it is provided. TI bases its knowledge and belief on information provided by third parties, and makes no representation or warranty as to the accuracy of such information. Efforts are underway to better integrate information from third parties. TI has taken and continues to take reasonable steps to provide representative and accurate information but may not have conducted destructive testing or chemical analysis on incoming materials and chemicals. TI and TI suppliers consider certain information to be proprietary, and thus CAS numbers and other limited information may not be available for release.

In no event shall TI's liability arising out of such information exceed the total purchase price of the TI part(s) at issue in this document sold by TI to Customer on an annual basis.

TAPE AND REEL INFORMATION



QUADRANT ASSIGNMENTS FOR PIN 1 ORIENTATION IN TAPE



*All dimensions are nominal

Device	Package Type	Package Drawing	Pins	SPQ	Reel Diameter (mm)	Reel Width W1 (mm)	A0 (mm)	B0 (mm)	K0 (mm)	P1 (mm)	W (mm)	Pin1 Quadrant
ADS7029QDCURQ1	VSSOP	DCU	8	3000	180.0	8.4	2.25	3.35	1.05	4.0	8.0	Q3

TAPE AND REEL BOX DIMENSIONS



*All dimensions are nominal

Device	Package Type	Package Drawing	Pins	SPQ	Length (mm)	Width (mm)	Height (mm)
ADS7029QDCURQ1	VSSOP	DCU	8	3000	223.0	270.0	35.0



4225266/A 09/2014

NOTES:

1. All linear dimensions are in millimeters. Any dimensions in parenthesis are for reference only. Dimensioning and tolerancing per ASME Y14.5M.
2. This drawing is subject to change without notice.
3. This dimension does not include mold flash, protrusions, or gate burrs. Mold flash, protrusions, or gate burrs shall not exceed 0.15 mm per side.
4. Reference JEDEC registration MO-187 variation CA.

EXAMPLE BOARD LAYOUT

DCU0008A

VSSOP - 0.9 mm max height

SMALL OUTLINE PACKAGE



LAND PATTERN EXAMPLE
EXPOSED METAL SHOWN
SCALE: 25X



4225266/A 09/2014

NOTES: (continued)

- 5. Publication IPC-7351 may have alternate designs.
- 6. Solder mask tolerances between and around signal pads can vary based on board fabrication site.

EXAMPLE STENCIL DESIGN

DCU0008A

VSSOP - 0.9 mm max height

SMALL OUTLINE PACKAGE



SOLDER PASTE EXAMPLE
BASED ON 0.125 mm THICK STENCIL
SCALE: 25X

4225266/A 09/2014

NOTES: (continued)

7. Laser cutting apertures with trapezoidal walls and rounded corners may offer better paste release. IPC-7525 may have alternate design recommendations.
8. Board assembly site may have different recommendations for stencil design.

IMPORTANT NOTICE AND DISCLAIMER

TI PROVIDES TECHNICAL AND RELIABILITY DATA (INCLUDING DATA SHEETS), DESIGN RESOURCES (INCLUDING REFERENCE DESIGNS), APPLICATION OR OTHER DESIGN ADVICE, WEB TOOLS, SAFETY INFORMATION, AND OTHER RESOURCES "AS IS" AND WITH ALL FAULTS, AND DISCLAIMS ALL WARRANTIES, EXPRESS AND IMPLIED, INCLUDING WITHOUT LIMITATION ANY IMPLIED WARRANTIES OF MERCHANTABILITY, FITNESS FOR A PARTICULAR PURPOSE OR NON-INFRINGEMENT OF THIRD PARTY INTELLECTUAL PROPERTY RIGHTS.

These resources are intended for skilled developers designing with TI products. You are solely responsible for (1) selecting the appropriate TI products for your application, (2) designing, validating and testing your application, and (3) ensuring your application meets applicable standards, and any other safety, security, regulatory or other requirements.

These resources are subject to change without notice. TI grants you permission to use these resources only for development of an application that uses the TI products described in the resource. Other reproduction and display of these resources is prohibited. No license is granted to any other TI intellectual property right or to any third party intellectual property right. TI disclaims responsibility for, and you will fully indemnify TI and its representatives against, any claims, damages, costs, losses, and liabilities arising out of your use of these resources.

TI's products are provided subject to [TI's Terms of Sale](#) or other applicable terms available either on [ti.com](https://www.ti.com) or provided in conjunction with such TI products. TI's provision of these resources does not expand or otherwise alter TI's applicable warranties or warranty disclaimers for TI products.

TI objects to and rejects any additional or different terms you may have proposed.

Mailing Address: Texas Instruments, Post Office Box 655303, Dallas, Texas 75265
Copyright © 2023, Texas Instruments Incorporated